

SERIES 2006 FRYER MANUAL



"Serving Those Who Serve The Very Best"

Keating's INCREDIBLE FRYING MACHINE®

READ AND SAVE THIS MANUAL FOR FUTURE REFERENCE

Record the Model No. and Serial No. of this Incredible Frying Machine® in the space provided below.

Serial No. _____

Model No. _____

Keep these numbers for future reference

IMPORTANT: Keep a copy of your bill of sale. The date on the bill establishes the warranty period should service be required. If service is performed, it is in your interest to obtain and keep all receipts. Keating commercial fryers are intended for other than household use.

CONTENTS:

SECTION I INTRODUCTION

General	1
Standard Features	1
Standard Accessories	1
Options	1
Ratings	1
Model Variations	1
Safety Precautions	1-2

SECTION II INSTALLATION

Damage During Shipment	3
Installation	3
Leveling	3
Restraining Devices	3
Gas Connection	4
Electrical Connection	4
Gas Leak Testing	4
Gas Pressure	5

SECTION III OPERATING THE FRYER

Filling	5
Lighting	5-6
Cooking	6
Shutdown	6
Digital Timers	6-7
Draining	7
Cleaning and Boil-Out	7-8

SECTION IV MAINTENANCE

Warranty Repairs	9
Preventive Maintenance	9
Oil Breakdown	9
Thermostat Calibration	9
Thermostat Bulb Positioning	9-10

SECTION V SERVICE DIAGNOSIS

Thermostat Test	10
Flame Adjustment	10

SECTION VI SERVICE

Trouble Shooting Charts	11-14
-------------------------------	-------

SECTION VII PARTS LIST

Ordering Parts	15
Warning and Operating Plates	15
IFM Gas Fryer Model 2000 Parts List	15
IFM Gas Fryer Model 2000 Assembly I	16
IFM Gas Fryer Model 2006 Parts List	17
IFM Gas Fryer Model 2006 Assembly II	18
IFM Gas Fryer Assembly III	19
IFM Control Panel Parts List	20-25
IFM Burner Assembly Parts List	26
Basket Lift Assembly Parts List	27

SECTION VIII WIRING DIAGRAMS

14IFM Wiring	28-39
Warranty	40

This Owner's Guide provides specific operating instructions for your model. Use the Incredible Frying Machine® only as instructed in this Service Guide.

1-800-KEATING
www.keatingofchicago.com



POST THIS LABEL IN A PROMINENT LOCATION ON YOUR UNIT

IMPORTANT

**IN THE EVENT A GAS ODOR IS DETECTED,
SHUT DOWN UNITS AT MAIN SHUT OFF VALVE
AND CONTACT THE LOCAL GAS COMPANY OR
GAS SUPPLIER FOR SERVICE.**



FOR YOUR SAFETY

**DO NOT STORE OR USE GASOLINE OR OTHER
FLAMMABLE VAPORS OR LIQUIDS IN THE VICINI-
TY
OF THIS OR ANY OTHER APPLIANCE.**



WARNING

**IMPROPER INSTALLATION, ADJUSTMENT,
ALTERATION, SERVICE OR MAINTENANCE CAN
CAUSE PROPERTY DAMAGE, INJURY OR DEATH.
READ THE INSTALLATION, OPERATING AND MAIN-
TENANCE INSTRUCTIONS THOROUGHLY BEFORE
INSTALLING OR SERVICING THIS EQUIPMENT.**

***As continuous product improvement occurs, specifications may be changed without notice.**

INTRODUCTION

Keating's Incredible Frying Machine® (IFM) are designed to give maximum production efficiency, delivering high quality food products. The following design features are incorporated in Keating's Incredible Frying Machine® (IFM).

STANDARD FEATURES

- Highly polished stainless steel fryer vessel
- Highly polished stainless steel front
- Highly polished stainless steel heat transfer tubes
- Highly polished stainless steel thermostat bulb
- Highly polished stainless steel Hi-Limit bulb
- Complete stainless steel cabinet
- True Cold Zone for proper sedimentation
- Grid screen over heat transfer tubes
- 1" full port front drain valve
- Patented accurate temperature control system $\pm 2^{\circ}\text{F}$
- Ideal 35" working height
- 3/4" NPT gas connection on single fryers
- One pair of split baskets or one full-size basket
- Patented burner design
- Spark Ignition system
- 100% proof of air flow safety shut-off
- 100% proof of flame safety shut off
- Digital timers (2) (where applicable)
- Gas and air adjustments
- Gas pressure test port
- Blower grease filter (easily accessible from front)
- Easy access for servicing from front of fryer
- Burner, blower and Hi-Limit indicating lights
- Insulated fryer vessel
- Heat recirculation for higher efficiency and lower flue temperature
- Black heat tube interiors for optimum heat transfer
- Instant-On™ ignition system (where applicable)
- 120 VAC 9' neoprene cord with 3-pronged grounded plug
- Instant recovery to cooking temperature
- High temperature stainless steel flue lining
- 100% factory testing

STANDARD ACCESSORIES

- Keating Klenzer Sample
- Drain clean out rod

OPTIONS

- Natural Gas or Propane
- Automatic Basket-Lift
- Cooking Computer

RATINGS

- 14" fryer vessel - 38 lb. oil capacity
- 18" fryer vessel - 68 lb. oil capacity
- 20" fryer vessel - 100 lb. oil capacity
- 7" W.C. (Natural Gas) or 11" W.C. (Propane) Line Gas Pressure.
- 3" WC (Natural Gas) or 10" WC (Propane) manifold gas pressure.
- 3/4" gas supply pipe recommended

MODEL VARIATIONS

Basket-Lift Model: Basket-Lift Model Fryers come with all the same features as the standard models. The Basket-Lift mechanism lowers the baskets of food into the oil when the timer button is pressed and raises the baskets when the cooking cycle is complete. Split baskets are required for these models.

CPU Model: CPU Incredible Frying Machine (IFM) have the same input as the standard models. A programmable computer replaces the two timers and thermostat.

SAFETY PRECAUTIONS

WARNING

THIS SYMBOL WARNS YOU THAT SERIOUS BURNS OR OTHER INJURIES MAY RESULT IF SAFETY INSTRUCTIONS ARE NOT FOLLOWED.

- This service manual should be retained in a safe place for future reference. The installation of your new fryer must conform to local codes or in the absence of local codes, with the current National Fuel Gas Code ANSI Z223.1/NFPA 54 (latest edition), Natural Gas Installation Code CAN/CGA-B149.1 or Propane Installation Code CAN/CGA-B149.2.
- Your ventilation hood, when installed, must conform to the current ANSI/NFPA 96 standard (latest edition).
- No frame or restriction shall be constructed around the fryer that will restrict air movement into the fryer's combustion area or prevent proper ventilation.
- Keating fryers are designed to operate on the gas fuel specified on the serial plate and must not be operated with another gas fuel. They cannot be converted to another gas fuel by turning or engaging a switch.

⚠️ WARNING

DO NOT STORE OR USE GASOLINE OR OTHER FLAMMABLE VAPORS AND LIQUIDS IN THE VICINITY OF THIS OR ANY APPLIANCE.

You will post, in a prominent location, instructions to be followed in the event the user smells gas. This information shall be obtained from your local gas supplier.

IMPORTANT: IN THE EVENT A GAS ODOR IS DETECTED, SHUT DOWN UNIT AT MAIN SHUT-OFF VALVE AND CONTACT THE LOCAL GAS COMPANY OR GAS SUPPLIER FOR EMERGENCY SERVICE.

- Suitable for installation on non combustible floors.
- You must maintain this appliance free and clear from combustibles.
- You must maintain the following minimum clearances from combustible and noncombustible construction:
- You must install this appliance at least 16 inches away from any open flame.
- Adequate clearance for servicing and proper operation must be maintained. Your fryer is designed to be serviced from the front.

Clearances		
	Combustible Construction	Noncombustible Construction
Back	6"	0"
Right Side	6"	0"
Left Side	6"	0"

- Keating commercial fryers are intended for other than household use.
- ALWAYS instruct new employees on proper fryer operation.
- A fryer should be operated ONLY by properly trained personnel.
- ALWAYS turn fryer off each night.
- ALWAYS disconnect fuel source before servicing.
- NEVER leave a fryer unattended during operation.
- NEVER move a fryer when full of hot oil.
- NEVER introduce objects or liquids into fryer, while operational, which are not designed or made for cooking.
- THIS FRYER MAY NOT BE ALTERED, MODIFIED OR CHANGED IN ANY WAY.

The State of California enacted the California Safe drinking water and Toxic Enforcement Act of 1986, (Prop. 65), which "prohibits any person in the course of doing business from knowingly and intentionally

exposing any individual to a chemical known to the State of California to cause cancer or reproductive toxicity without first giving clear and reasonable warning to such individuals." The Governor's Scientific Advisory Panel added carbon monoxide to the list of hazardous chemicals known to cause reproductive harm.

Carbon monoxide would not be present in concentrations that would pose a "significant risk" to the consumer when the equipment is installed, operated and maintained as follows:

- Installed in accordance with all local codes, or in the absence of local codes, with the current National Fuel Gas Code ANSI Z223.1/NFPA 54 (latest edition).
- Installed under a properly designed operating exhaust hood.
- Connected to the type of gas for which the appliance is manufactured.
- In-line pressure regulator, not supplied by Keating, must be installed outside the appliance to maintain proper incoming gas pressure (7" W.C. Natural, 11" W.C. L.P.).
- The appliance is adjusted for the manifold pressure marked on the serial plate.
- Adequate air supply to the appliance.
- The equipment is operated in the manner intended using the proper utensils.
- Keep the equipment clean and have it checked periodically.
- Burner air adjustments, mechanical maintenance and repairs must be performed by qualified service personnel.

If the equipment is not installed, operated and maintained in accordance with the above, concentrations of carbon monoxide in excess of the established limits could be present in the kitchen environment.

INSTALLATION

This fryer **MUST** be installed, inspected, calibrated and serviced by qualified and/or certified and/or licensed service personnel - you may void your Keating warranty if installation is not completed per local, national and Keating specifications. Contact your dealer for assistance.

DAMAGE DURING SHIPMENT

The fryer has been assembled, tested and inspected at the factory. Upon arrival, the complete fryer should be checked for any damage that may have occurred during shipment.

The carrier is responsible for all damage in transit whether visible or concealed. Do not pay for the freight bill or sign the Bill of Lading until the fryer has been thoroughly checked for damage. If concealed damage is found later, contact the carrier immediately to file a claim.

What to do if equipment arrives damaged:

VISIBLE LOSS OR DAMAGE - Be certain to note this on the freight or express receipt and have it signed by the delivery person.

FILE CLAIM FOR DAMAGES IMMEDIATELY - Regardless of extent of damage. This claim must be filed with the carrier.

CONCEALED LOSS OR DAMAGE - If damage is noticed when equipment is unpacked, notify the freight company immediately, and file a "concealed damage claim". This **MUST** be done immediately. Be sure to retain the shipping container for inspection.

Keating does not assume responsibility for Loss OR Damage incurred in transit. Keating's sole responsibility in such cases will be to provide support in determining the extent of the parts, labor, and cost thereof needed to return said equipment to new condition.

INSTALLATION

Installation must conform with local codes or, in absence of local codes, with the current National Fuel Gas Code Z223.1/NFPA 54 (latest edition), Natural Gas Installation CAN/CGA - B149.1 or Propane Installation Code CAN/CGA-B149.2. When pressure testing at test pressures less than or equal to 1/2 psig (3.45 KPA), fryer **must be isolated** from gas supply piping. When pressure testing at test pressures above 1/2 psig (3.45 KPA), fryer **must be disconnected** from gas supply piping system.

Counter model and floor model fryers must be restrained to prevent tipping when installed in order to avoid splashing, spilling, etc. of hot liquid. The restraining method may be a manner of installation or by separate means.

LEVELING

The fryer will operate at its highest efficiency when properly leveled. Place a level on fryer vessel from side to side. For fryers on legs, the bottom foot of the leg is adjustable. Turn clockwise to decrease height or counter clockwise to increase height until level. For fryers on casters, the casters are adjustable by loosening the jam nut and turning the caster in or out. When the desired level is reached, tighten the jam nut. Adjustments of more than 3/4" are not recommended on any caster. The same procedure should be followed to level the fryer from front to back.

Figure 2-1

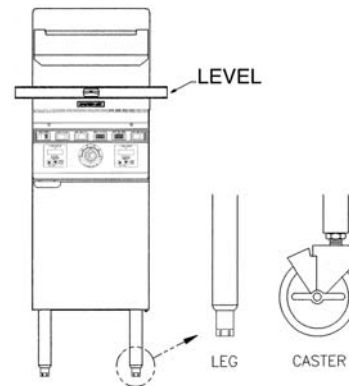

RESTRAINING DEVICES

1.) Adequate means must be provided to limit the movement of the appliance without depending on the connector and the quick-disconnect device or its associated piping to limit the appliance movement.

Fryer must also be restrained to prevent tipping when installed so that hot liquid splashing is avoided.

2.) The restraint means must be attached to the rear of the Keating IFM within 2" of the center line width and approximately 1 5/8" from the bottom of the cabinet back to allow the restraining bolt to be anchored to the cabinet back between the cabinet bottom and inner liner.

IF DISCONNECTION OF THE RESTRAINT IS NECESSARY, IT MUST BE RECONNECTED WHEN THE KEATING IFM IS RETURNED TO ITS ORIGINALLY INSTALLED POSITION.

NOTICE:

WHEN THIS APPLIANCE IS INSTALLED WITH CASTERS, IT MUST BE INSTALLED WITH CASTERS SUPPLIED, A CONNECTOR COMPLYING WITH EITHER ANSI Z21.69 OR CAN/CGA - 6.16 AND A QUICK-DISCONNECT DEVICE COMPLYING WITH EITHER ANSI Z21.41 OR CAN1- 6.9. IT MUST ALSO BE INSTALLED WITH RESTRAINING MEANS TO GUARD AGAINST TRANSMISSION OF STRAIN TO THE CONNECTOR, AS SPECIFIED IN THE APPLIANCE MANUFACTURER'S INSTRUCTIONS.

INSTALLATION

The installer is responsible for attaching the tipping restraint.

ELECTRICAL CONNECTION

The Keating IFM, when installed, must be electrically grounded in accordance with local codes, or in the absence of local codes, the National Electrical Code, ANSI/NFPA No. 70. or the Canadian Electrical Code, CSAC-22.2 as applicable. A wiring diagram is located on the last page. In the U.S.A. and Canada, the electrical supply must be 120 VAC, 60 Hz.

The Keating Incredible Frying Machine (IFM) is equipped with a 9' neoprene covered, 3 wire electrical cord with a three-pronged grounded plug for protection against electrical shock. This plug must be placed into a 120V properly grounded three-pronged polarized outlet. For proper grounding procedures see local codes, or in the absence of local codes, the National Electrical Code ANSI/NFPA 70 (latest edition) or Canadian Electrical Code CAN 22.2 (latest edition) as applicable.

CAUTION

Before plugging in the fryer, confirm the outlet is properly polarized and grounded. If the hot and neutral terminals are reversed or the outlet is not properly grounded, the burners may not ignite (burner on light will go out after 2-1/2 seconds and the ignition processes will continue 3 times).

WARNING



THIS APPLIANCE IS EQUIPPED WITH A THREE-PRONG 120 VOLT NEMA 5-15 (GROUNDING) PLUG FOR YOUR PROTECTION AGAINST SHOCK HAZARD AND SHOULD BE PLUGGED DIRECTLY INTO A PROPERLY GROUNDING AND POLARIZED THREE-PRONG RECEPTACLE. DO NOT CUT OR REMOVE THE GROUNDING PRONG FROM THIS PLUG.

WARNING

IF DISCONNECTION OF THE RESTRAINT IS NECESSARY, IT MUST BE RECONNECTED WHEN THE FRYER IS RETURNED TO ITS ORIGINALLY INSTALLED POSITION.

GAS CONNECTION

WARNING

- **PIPE JOINT COMPOUNDS RESISTANT TO PROPANE GASES MUST BE USED.**
- **BEFORE OPERATING THIS FRYER, CHECK PIPE JOINTS FOR LEAKS BY USING A SOAP AND WATER SOLUTION ONLY. DO NOT USE AN OPEN FLAME!**

Figure 2-3

Main Gas Connection

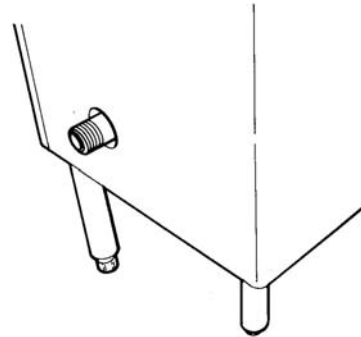

Connect the fryer to the main gas supply line at the rear of the fryer. The piping should be a minimum of 3/4" NPT supply pipe for a single fryer at the burner manifold. Batteries require larger supply lines. Installation must conform to the current local codes and National Fuel Gas Code (U.S.) ANSI Z223. 1/NFPA 54 (latest edition), Natural Gas Installation Code CAN/CGA-B149.1 or Propane Installation Code CAN/CGA-B149.2 (latest edition).

NOTE: If more than one gas fryer is on the same supply line, you may require a larger line. Consult your local gas company to assure adequate volume and pressure. Refer to serial plate for proper gas requirements for your particular model.

NOTE: Piping for a battery should be at least 1 1/4" to 1 1/2" IPS, depending on total BTU input. Consult your local gas supplier for appropriate battery piping size.

NOTE: The electrical wiring diagram for the fryer is located on the inside of the fryer door or in the back of this manual.

GAS LEAK TESTING

Prior to lighting your fryer:

1. Make sure all thermostats, switches and safety valves are in the "OFF" position.
2. Turn main On/Off manual gas valve to the "ON" position.
3. Have your plumber or gas company check for leaks with a soap solution. (NEVER check with an open flame!)

GAS PRESSURE AT MANIFOLD

NATURAL Gas - 3.0 in. W.C.

LP Gas - 10.0 in. W.C.

MAXIMUM INCOMING GAS PRESSURE

NATURAL Gas - 7.0 in. W.C.

LP Gas - 11.0 in. W.C.

NOTE: It is estimated that half of all service calls made on Keating Incredible Frying Machine® (IFM) result from an inadequate gas supply. During installation, have a gas company representative make certain that the fryer is receiving adequate gas pressure and volume (see “Installation” or your serial plate on the fryer door).

⚠ WARNING

PROPANE GAS MAY EVENTUALLY LOSE ITS ODOR AND PRECAUTIONS SHOULD BE TAKEN TO ASSURE THAT IT IS NOT PRESENT EVEN THOUGH YOU DO NOT DETECT AN ODOR. IF THERE IS ANY DOUBT, YOU SHOULD CALL YOUR LOCAL PROPANE GAS SUPPLIER FOR ASSISTANCE.

OPERATING

FILLING

NOTE: Before filling the fryer make certain the fryer vessel is sanitized, dry and the drain valve is completely closed. Refer to item 13 on page 16, or item 11 on page 18 for location of drain valve.

NOTE: We recommend that solid shortening not be used in an Incredible Frying Machine (IFM) as they are not equipped with a melt cycle. If solid shortening is used, it should be melted prior to filling the fryer vessel. Damage done by melting solid shortening in the fryer vessel will void the warranty.

⚠ WARNING

BE SURE THE HEAT TRANSFER TUBES ARE COMPLETELY COVERED WITH OIL BEFORE SWITCHING THE FRYER ON. IF OIL LEVEL DROPS BELOW TOP OF HEAT TRANSFER TUBES, SEVERE DAMAGE TO FRYER AND INJURY TO OPERATOR MAY RESULT.

⚠ WARNING

DO NOT MIX HOT OIL AND WATER IN ANY FORM.

⚠ CAUTION

Oil expands when heated. The “Max” line has been provided to ensure optimum cooking while ensuring the safety of the operator. Do not overfill the fryer vessel.

See Figure 3-1.

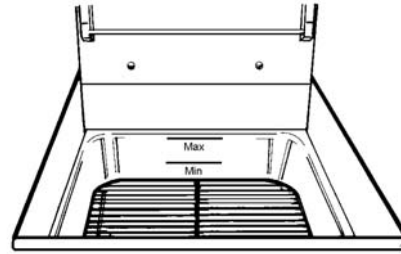

Figure 3-1

“Max” Level Line

Fill the fryer vessel with oil or MELTED solid shortening up to the “Max” line.

LIGHTING

⚠ WARNING

BEFORE ATTEMPTING TO LIGHT THE FRYER, MAKE SURE THE GAS CONNECTIONS ARE SECURE AND HAVE BEEN LEAK TESTED AND THE FRYER HAS BEEN PROPERLY FILLED WITH OIL.

Figure 2-4 IFM Control Panel

Control Panel with timers Model 2000

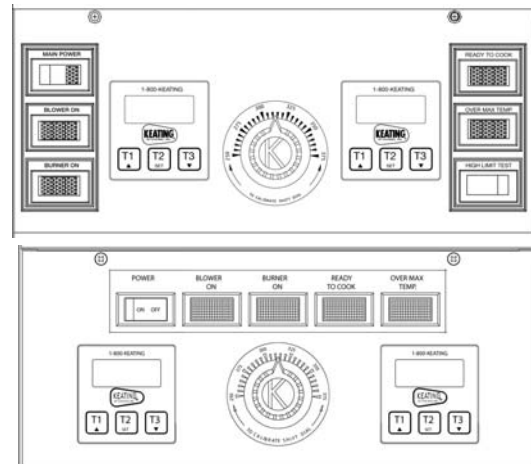

14” Control Panel with timers Model 2006

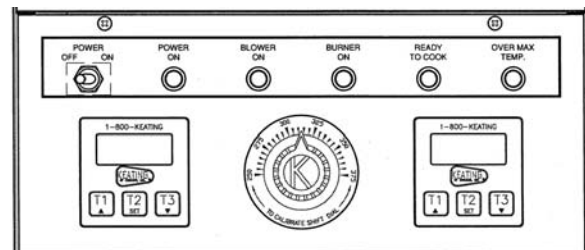

1. Turn on main power switch.
2. Set thermostat to desired setting. (Between 325°F/162.8°C) – (335°F/165.3°C)
3. Once main power switch is on and the thermostat is set, the following occurs:
 - a. Blower will start and blower indicating light will come on.
 - b. After a preset ten second delay, the gas valve will open and the burner indicating light will come on.
 - c. The spark module will light the burners automatically.
 - d. The burner indicating light will be on whenever the burners are on. The light goes off when the oil has reached the desired temperature. If the burners do not light immediately, the burner light will shut off, the blower light will stay on, and after 6 seconds, the burners will try to light again. This process will repeat 3 times.

NOTE: The fryer cannot be operated during a power failure as the electronic ignition system cannot be operated.

COOKING

Keating Incredible Frying Machine® Gas Fryers (IFM) are designed to provide maximum production efficiency and deliver high quality food products. Low- temperature cooking, highly polished stainless steel and a true COLD ZONE mean extended oil life. Follow cooking procedures below for your model.

WARNING

- **OPERATION OF THIS FRYER SHOULD BE LIMITED TO PERSONNEL WHO HAVE BEEN THOROUGHLY TRAINED IN OPERATING PROCEDURES.**
- **USE ONLY KEATING APPROVED BASKETS IN YOUR FRYER. NEVER OVERFILL FRY BASKETS. DO NOT BANG BASKETS ON BASKET HANGERS OR ON FRYER VESSEL.**
- **CARE SHOULD BE TAKEN WHEN LOWERING BASKETS INTO FRYER TO PREVENT SPLASHING HOT OIL FROM FRYER VESSEL.**
- **NEVER LIFT BASKETS DIRECTLY OUT OF THE FRYER VESSEL WITHOUT DRAINING, AS SEVERE INJURY MAY RESULT.**

1. Set thermostat to the desired frying temperature (between 325°F - 335°F).
2. When the oil reaches the desired temperature, burner indicating light will go off.

3. Set timer(s) to desired cooking time and fill basket(s) to proper level (if applicable).
4. Lower filled basket(s) slowly into oil. For fryers with automatic basket lift, place basket(s) on upper basket hanger rods on splashback of fryer.
5. Push “T1”, “T2” or “T3” button of electronic timer(s). This simultaneously activates the Instant-On™ systems (if applicable). For fryers with automatic basket lift, basket(s) will lower into fryer vessel.
6. When timer(s) sounds, carefully lift basket(s) out of hot oil (if applicable). For fryers with automatic basket lift, a buzzer will sound and the basket(s) will rise automatically. Allow oil to drain before removing.
7. Place basket(s) on basket hanger rods on splashback of fryer and allow to drain.

SHUT DOWN

Turn off main power switch.

DIGITAL TIMER (PART # 030834) RESETTING TO MINUTES : SECONDS

STEP 1

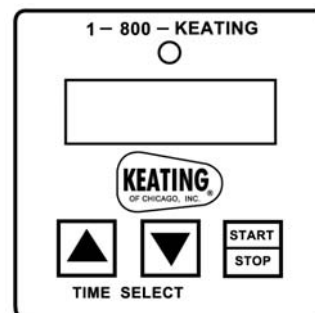

Make certain power to the timer has been OFF for at least 30 seconds. Then PRESS and hold down the UP arrow button while turning the rocker power switch to the ON position. The timer will turn ON and the display will now be indicating

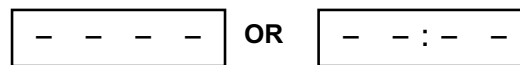

The BEEPER will BEEP 4 times.

If STEP 1 was OK, proceed to STEP 2. If not, retry Step 1 making sure the power was OFF for at least 30 seconds or more.

STEP 2 PRESS all 3 buttons in sequence: left-center-right. The BEEPER will BEEP. If BEEPER does not BEEP, the timer is defective. STOP TESTING. Reset procedure is completed when 1:00 appears on the digital display.

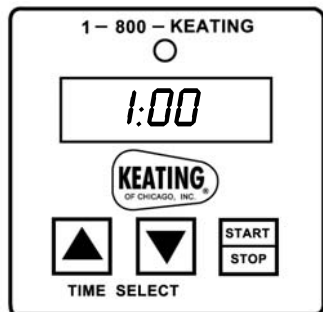

DIGITAL TIMER (PART # 030834)

PROGRAMMING

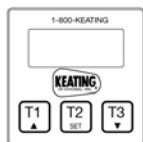

To program the timers, the unit must be in the idle mode. Press and hold the set button for approximately two seconds. The display will show "SEt". Press the button for the channel to be programmed. The display will show the current setting for that channel. Use the up or down button to increment or decrement the setting. When the setting is correct, press and hold the set button again for approximately two seconds. The display will show "StO" for approximately two seconds and the timer will return to normal operation. Repeat the process as necessary for the other timers.

OPERATING LOGIC

When the timer is powered up, the display will show the time setting for the channel that was operated last and the relay output contacts will be open. To start a cycle, press the desired channel button (1-3). The display will begin to countdown from the preset time setting and the relay output contacts will close. During the countdown the colon will flash at a one-second rate. When the countdown has reached "00:00" the relay output contacts will open, the display will flash, and the audible alarm will sound. To cancel the audible alarm, press any button.

PAUSE FEATURE

To pause a cycle in progress, press any button. The relay output contacts will open, the display will flash, and the countdown will pause. To resume the countdown, press any button. The display will resume the normal countdown and the relay output contacts will close.

CANCELING A CYCLE

To cancel a cycle in progress press and hold any button for approximately two seconds. The relay output contacts will open and the display will show the time setting for the channel last used.

DRAINING

⚠ WARNING

ALWAYS SHUT THE FRYER OFF COMPLETELY BEFORE DRAINING. THE FRYER SHOULD BE DRAINED ONLY UNDER THE SUPERVISION OF PROPERLY TRAINED PERSONNEL. A DRAIN PIPE AND COVERED CONTAINER SUITABLE FOR USE WITH HOT OIL SHOULD BE USED TO ENSURE THE SAFETY OF THE OPERATOR.

1. Operator should be outfitted with proper attire including:
 - Oil and heat resistant gloves
 - Oil and heat resistant apron
 - Safety goggles
 - Oil and heat resistant footwear



Figure 3-2

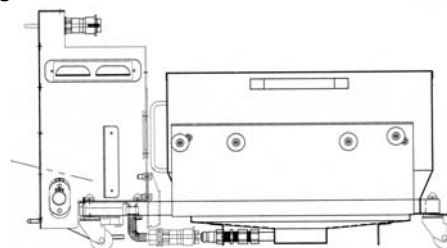

Side view of Safe & Easy Filter

2. Turn off the fryer and open the door.
3. Put suitable container under drain valve (for Safe & Easy models, slide filter onto rails inside of fryer or filter cabinet).
4.
 - Front Drain: Drain oil from fryer by slowly turning handle. The drain will be completely open after 1/4 turn.
 - Rear Drain: Pull black knob forward slowly.
5. After fryer drains, close the drain valve.
6. Filtering may be done at this step - refer to filter manual.

CLEANING AND BOIL-OUT

When cleaning and boiling out your fryer use Keating Sea Powder and Keating Klenzer to keep your fryer in top condition. Keating Sea Powder dissolves any grease build up — even carbonized grease in fryer vessels — one of the leading causes of premature oil breakdown. Once your fryer vessel is clean, use Keating Klenzer, the finest dry stainless steel polish available, to restore your Keating Incredible Frying Machine®'s (IFM) exterior to its original luster.

Figure 3-4

Keating Klenzer and Sea Powder



1. Put on safety attire. See Draining.
2. Turn the fryer off
3. Drain oil from fryer, see draining steps 2-4 above.
4. Remove oil container to a secure area to prevent accidental spillage.
5. Fill fryer vessel to “Max” line with water.

⚠ WARNING

UNDER NO CIRCUMSTANCES SHOULD THE FRYER BE LEFT UNATTENDED DURING BOIL-OUT. TRAINED PERSONNEL MUST BE PRESENT DURING THE PROCEDURE TO PREVENT BOIL OVER OR TO TURN OFF THE POWER IF WATER DROPS BELOW HEAT TRANSFER TUBES.

6. Set thermostat and turn fryer on to bring water to a gentle boil.
7. Once boil has been reached, turn fryer off.
8. Dissolve $\frac{2}{3}$ cup of Keating Sea Powder for every five gallons of water and let soak for $\frac{1}{2}$ hour. If there is a large build-up of carbonized grease, allow fryer to soak overnight.

CAUTION: When soaking overnight, make sure the fryer is turned off.

CAUTION: Do not damage or reposition thermostat probe as this may affect the accuracy of the fryer.

9. While soaking, a natural fiber brush may be used to scrub the tubes and inside walls of fryer.
10. Drain the water and Sea Powder into a dry suitable receptacle and remove from cooking area.

NOTE: DO NOT pump water through the filter machine.

11. Spread Keating Klenzer liberally on tubes and sides of fryer vessel.
12. A non-abrasive scouring pad may be used to remove the now softened carbonized grease.
13. Thoroughly rinse fryer vessel with potable water to remove all Klenzer.

14. Prior to refilling with oil, wipe the inside of the fryer vessel making sure all water and Klenzer has been removed.

⚠ WARNING

DO NOT MIX HOT OIL AND WATER IN ANY FORM.

15. Close drain valve.

⚠ WARNING

FAILURE TO CLOSE DRAIN VALVE BEFORE REFILLING THE FRYER MAY RESULT IN SERIOUS INJURY.

16. Check thermostat bulb positioning – see page 9.
17. Refill the fryer with new oil.

MAINTENANCE

WARRANTY REPAIRS

Keating's warranty begins with the date of installation (or ship date if we are not notified of an installation date).

In the event that your fryer, under warranty, needs repairs other than routine maintenance or cleaning, you are required to contact Keating of Chicago (at 1-800-KEATING) before calling a local service company. Failure to do so may void your warranty.

PREVENTIVE MAINTENANCE

Preventive maintenance should be done in daily, weekly, monthly and yearly intervals as necessary. Following preventive maintenance procedures will help keep your fryer working efficiently. Proper care and servicing will lead to years of quality performance.

A. Oil Breakdown

As part of a "Preventive Maintenance Program", the oil in your fryer needs to be filtered regularly to avoid breakdown. The initial investment in the frying system is less than the total overall costs of oil during the life of the fryer, and with regular filtering, you can realize substantial savings in oil costs, as well as maintenance charges.

PREVENTIVE MAINTENANCE CHART		
TIME FRAME	OPERATOR/OWNER	SECTION
Daily*	<ul style="list-style-type: none"> Check lights and controls Check that the oil is up to "Max" line. Clean all baskets Drain, strain or filter shortening. 	III
Weekly*	<ul style="list-style-type: none"> Drain and clean fryer Boil-out fryer 	III & VI
Monthly*	<ul style="list-style-type: none"> Verify thermostat settings. Test Hi-Limit control. 	III IV & V
Yearly*	<p>QUALIFIED SERVICE PERSONNEL ONLY</p> <ul style="list-style-type: none"> Check burner flame color and adjust air shutters. 	V

* High production facilities should be checked more often.

B. Thermostat Calibration

You will need:

- One screwdriver with 1/8" wide flat blade
- One accurate fryer thermometer

- Set thermostat to desired frying temperature.
- Allow fryer to cycle three times.

- Place an accurate thermometer in the oil at the tip of the thermostat bulb.

Figure 4-1

Dial Plate with knob removed

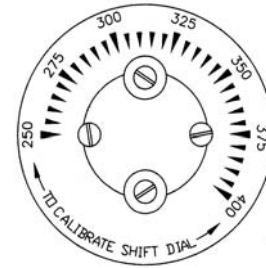

NOTE: Locate thermometer in same position for every calibration.

- If calibration of fryer is found to be less than 25°F off, simply loosen the four retaining screws holding the dial plate in place. Reset the dial plate to match the thermometer reading. If the fryer is found to be more than 25°F off, a qualified service company must be contacted to have the fryer properly calibrated.

CAUTION

Do NOT adjust set screw on thermostat.

C. Thermostat Bulb Positioning

BEFORE REPLACING, TEST THERMOSTATS:

Operational problems can easily be corrected by thermostat bulb positioning.

Keating's patented thermostat application is accurate within 2°F of the dial setting between 250°F – 350°F. This accuracy is attained only if the thermostat bulb is placed properly against the heat transfer tube. To quickly and accurately test for proper bulb placement, a single thickness of writing paper should be pulled through between the tube and the bulb with medium resistance.*

1. *For gas fryers 14":

- The end of thermostat bulb should touch the burner tube.

2. For gas fryers 18" & up:

- If the bulb is too loose, the paper will slip through with little or no resistance. A fryer with a thermostat bulb that is too loose will overshoot.

Overshoot: The thermostat takes a long time to cycle and then misses its preset temperature by 20°F - 40°F yielding a poor quality product.

- If the bulb is too tight, the paper will either not pull through or it will tear. A fryer with a thermostat bulb that is too tight will short cycle.

Short Cycle: The thermostat will cycle rapidly while the fryer is in the idle mode; the temperature will be erratic.

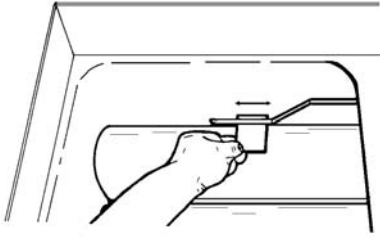

Thermostat Bulb Positioning 18" & up Fryer Gas

SERVICE

⚠ WARNING

ALL HI-LIMIT CONTROLS ARE PRESET AT THE FACTORY FOR A SPECIFIC TEMPERATURE. DO **NOT** ATTEMPT TO CHANGE THE SETTING OF THE HI-LIMIT. IF THE HI-LIMIT FAILS TO SHUT OFF BETWEEN 425°F AND 450°F DURING TESTING, IT MUST BE REPLACED.

FLAME ADJUSTMENT

A. Gas Pressure

1. At gas valve, remove adjustment port cover, rotate adjustment screw with screwdriver and replace port cover.
2. To check the gas pressure (3" WC for natural gas or 10" WC for Propane at the manifold), use an allen wrench to remove the gas pressure test port, located in the center of the manifold.
3. Line pressure (incoming pressure) is critical for proper ignition of the IFM. Incoming pressure must be :
 Natural - 7" W.C.
 Propane - 11" W.C.

B. Air Flow

1. To determine the proper gas/air mixture, look into the viewing window for each burner, located just to the left of each burner air hose where the hose is connected to the burner assembly. (See figure below).
 - bright red/orange with proper mixture – orange "glow" around burner tube
 - too much gas – orange "haze" around burner tube (showing incomplete combustion)
 - too little gas – blue at front of burner, or totally blue

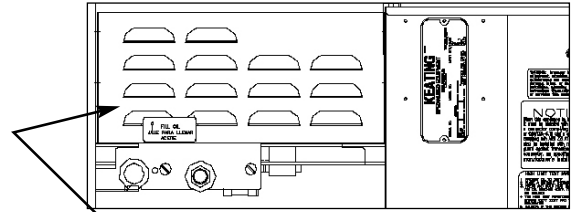

Remove the cover by loosening the screws to gain access to the burner viewing windows (14" Model Shown).

REQUIRED TEST THERMOSTAT

Multimeter (for testing continuity)

CHECKING CONTINUITY WITH THE MULTIMETER

1. Rotate the thermostat shaft until an audible click is heard.
2. Rotate the thermostat shaft left and right ten times causing the switch to click on and off ten times, while using the Multimeter to verify continuity.
3. If the switch does not show continuity during all ten trials, replace the thermostat.

⚠ CAUTION

Disassembling the thermostat will void the thermostat warranty.

1. Set compression ring onto capillary end of bulb finger tight, 1/2" from end of capillary.
2. Insert new thermostat bulb through control panel back.
3. Apply oil resistant flexible sealant onto compression fitting thread before installing fitting into fryer vessel.
4. Position bent portion of bulb against far right heat transfer tube and install compression fitting snugly into fryer vessel.
5. Adjust bulb so at least 2" of bent portion of it is next to heat transfer tube and tighten compression nut onto compression fitting for fryer 18 & up. The end of thermostat bulb should touch the burner tube for 14" fryers.
6. Refill fryer with oil to "fill level line".
7. Start fryer, preheat and calibrate with thermometer.

SERVICE DIAGNOSIS

A properly adjusted Keating Incredible Frying Machine® (IFM), with no load, will cycle "On" approximately every 2 1/2 to 3 minutes. Each cycle will last 15 to 25 seconds, ensuring that the temperature setting is held within a narrow band.

- Every Keating Incredible Frying Machine® (IFM) has a number of safety controls to ensure safe operation and guard against component failure.

SELF-HELP GUIDE

Common Problems	Probable Cause	Solutions (Follow Sequentially)
<p>1. No power to unit.</p> <p>a. Power switch light ON only.</p> <p>b. Power Switch light and Red overmax temperature light on.</p> <p>c. All lights are off.</p>	<p>a. Drain handle not locked into place.</p> <p>b. High limit light has tripped.</p> <p>c. Breaker has tripped.</p>	<p>a. Locate the handle used to drain oil from fryer. Pull handle up and push it in as far as possible, locking it into place and activating the safety switch.</p> <p>b. Reset the high-limit (press the red button located in the bottom of the control panel).</p> <p>c. Reset the breaker located on the bottom of the control panel, check the outlet or check the breaker at the wall.</p>
<p>2. Timers (or lights) ON but fryer does not try to light.</p>	<p>a. Thermostat off.</p>	<p>a. Set the thermostat to desired temperature.</p>
<p>3. Blower light on. Red burner light comes on and goes out after about 3 seconds.</p>	<p>a. Problem with the outlet at the wall.</p> <p>b. Gas not turned on or not hooked up.</p>	<p>a. Plug fryer in to a different electrical outlet (must be properly grounded).</p> <p>b. Ensure gas hose is securely connected. Turn on main gas.</p>
<p>4. Not recovering.</p>	<p>a. Gas pressure incorrect.</p> <p>b. Thermostat not calibrated.</p> <p>c. Overloading fryer.</p>	<p>a. Contact service agent to verify proper gas pressure.</p> <p>b. Calibrate the thermostat by rotating the dial plate to match the actual temperature of the oil (See page 9).</p> <p>c. Do not overfill baskets with food.</p> <p>d. Do not overfill fryer with oil (check the fill level stamped into the fry pot).</p>

TROUBLESHOOTING CHART

The following diagnosis is only to be used as a guide to qualified service personnel. Keating recommends that you use a qualified service company. Call 1-800-KEATING if you need assistance in locating a qualified service company.

NOTE: To correctly and quickly diagnose the system, the chart below must be followed in sequential order.

Problem	Probable Cause	Solution
Main power light does not come on.	<ul style="list-style-type: none"> a. Fryer not plugged in. b. Breaker has tripped. c. Main power switch is faulty. 	<ul style="list-style-type: none"> a. Plug fryer into approved outlet. Must be properly grounded. b. Reset the breaker located on the bottom of the control panel c. Replace the main power switch.
Blower light does not come on.	<ul style="list-style-type: none"> a. Thermostat not turned on. b. If blower comes on, blower light is faulty. c. If Over Maximum Temperature light is on, Hi-Limit has been activated. d. If unit has a filter, drain handle not locked into place. 	<ul style="list-style-type: none"> a. Set thermostat to desired temperature. b. Replace blower light. c. Reset Hi-Limit after oil has cooled down below 425°F. Correct problem which caused Hi-Limit to activate (See page 10). d. Secure drain handle in place behind the bracket.
Burner light does not come on.	<ul style="list-style-type: none"> • <i>Check for flame at each burner. If no flame is present at either burner:</i> a. Spark module is faulty. • <i>Check for flame at each burner. If flame is present at both burners:</i> b. Burner light is faulty. 	<ul style="list-style-type: none"> a. Replace spark module. b. Replace burner light.
Burner light comes on, then goes out (after 2 1/2 seconds).	<ul style="list-style-type: none"> • <i>Check for spark at each burner. If no spark at either burner:</i> a. Spark electrode wires are not tight or faulty. b. Spark electrode is faulty or is out of alignment. • <i>Check for spark at each burner. If spark occurs at both burners:</i> c. Gas is not hooked up properly or not turned on. d. Spark electrode is faulty or is out of alignment. e. Combination gas valve is faulty. 	<ul style="list-style-type: none"> a. Tighten spark electrode wires or replace. b. See detail on page 26. c. Turn manual gas valve on. If using flexible connector with quick disconnect, make sure that the quick disconnect is completely engaged. d. Align spark electrode. Replace spark electrode if faulty. Gap must be 1/8" between electrode and pilot tube and between pilot tube and burner (See page 26). e. Replace combination gas valve after verifying it has voltage.

Problem	Probable Cause	Solution
Delayed ignition.	<ul style="list-style-type: none"> a. Spark electrode gap is incorrect. b. Gas pressure excessive (incoming or manifold). c. Spark module intermittent. 	<ul style="list-style-type: none"> a. Set proper gap on electrode (See detail on Page 26). b. Set pressure to serial plate. c. Replace spark module.
Fryer has poor recovery.	<ul style="list-style-type: none"> a. Over-filling baskets. b. Over-filling fryer with oil. c. Thermostat bulb improperly placed. d. Carbon coating on heat transfer tubes. e. Low gas pressure or volume. f. Inefficient burner combustion. 	<ul style="list-style-type: none"> a. Don't over-fill baskets. b. Fill fryer up to "Fill Level" line as oil will expand when heated. c. Adjust bulb position. See page 9 – Thermostat Bulb Positioning. d. Boil-out fryer. See page 7 – Cleaning and Boil-out. e. Contact a qualified service person to check gas pressure. f. Adjust gas/air mixture. See page 10 – Flame Adjustment.
Fryer overshoots temperature setting.	<ul style="list-style-type: none"> a. Thermostat bulb improperly placed. b. Thermostat out of calibration. 	<ul style="list-style-type: none"> a. Adjust bulb position. See page 9 – Thermostat Bulb Positioning. b. Calibrate thermostat. See page 9 – Calibration.
Oil in fryer vessel smokes.	<ul style="list-style-type: none"> a. Oil has begun to break down. b. High carbon content in oil. c. Dirty fryer vessel. d. Inferior grade of oil. e. Fryer is overheating. 	<ul style="list-style-type: none"> a. Replace oil. b. Filter oil completely, replace if necessary. c. Boil-out fryer. See page 7 – Cleaning and Boil-out. d. Check with supplier for the grade of oil you need for your cooking applications. e. Check calibration of thermostat (See page 9) and replace if necessary.
Basket lift mechanism will not operate.	<ul style="list-style-type: none"> a. Breaker tripped. b. Connections are loose or electronic timer is faulty. c. Actuator defective. 	<ul style="list-style-type: none"> a. Reset breaker located in rear of fryer. or on bottom of control panel back (Note Basket Lift circuit breaker is labeled). b. Make sure connections are tight. Replace timer if faulty. c. Replace actuator.

Problem	Probable Cause	Solution
Basket-lift motor runs, but basket does not move.	a. Actuator is faulty.	a. Replace actuator.
Basket(s) rise prematurely.	a. Electronic timer is faulty. b. Basket lift relay is faulty.	a. Replace timer. b. Replace relay.
Spark module flashing.	a. Steady OFF. b. Steady ON. c. 1 Flash. d. 2 Flashes. e. 3 Flashes. f. 4 Flashes. g. 5 Flashes.	a. NO Power or Control Hardware Fault. b. Power Applied; Control Okay. c. No flame sense (current trial only). Active until flame sense on next trial. d. Marginal flame between 1.5mA and 0.5mA. e. Ignition lockout; too many ignition failures: 1. Turn off unit. 2. Check incoming gas. 3. Spark at electrode. 4. Electrode. f. Ignition lockout; too many flame losses: 1. Turn off unit. 2. Check incoming gas. 3. Spark at electrode. 4. Electrode. g. Control hardware fault detected.

PARTS LIST

ORDERING PARTS

Parts may be ordered by part number by calling your local service company or Keating at 1-800-KEATING. You may also order on-line at Keating's part store, www.keatingofchicago.com.

Refer to the Keating Incredible Frying Machine® Limited Warranty for complete service and ordering information.

The model/serial plate is located on the inside of the front door. The serial and model numbers are necessary when ordering.

WARNING AND OPERATING PLATES

All warning and operating plates on the Keating Incredible Frying Machine® should be in place at all times. If plates are damaged or lost, replace them immediately.

INCREDIBLE FRYING MACHINE® GAS FRYER PARTS LIST - MODEL 2000

ITEM	MODEL	PART NO.	DESCRIPTION	QTY
1	14"	030862	Blower	1
	18" & 20"	053726	Blower	1
		052471	Insulation	2
2		054162	Air Hose	2
		015393	1/2" Clamp	2
3	Call 1-800-KEATING		Fry Pot	1
4		020717	Pilot Tee	1
5		022031	Pilot Tubing 1/8 S/S	2
6		016231	Elbow Brass 90°	2
		015390	Bushing	2
	14"	016502	Orifice #29	2
	18" & 20"	021869	Orifice #18	2
7		054512	Flexible Main Tubing	2
		054426	Flexible Main Tubing Elbow	2
8		054208	Flexible Pilot Tubing	2
9		053777	Magnetic Reed Switch	1
10		052572	Nipple Quick Connect	1
		053445	Rubber Grommet	1
11		031532	Knob Drain Handle	2
12		024030	Gas Valve Nat	1
		024988	LP	1
13	14"	016341	Drain Valve 1" Rear	1
	18" & 20"	016342	Drain Valve 1 1/4" Rear	1
14	ALL		Drain Valve Pull Rod Assembly	
		053650	Drain Valve Handle Rod	1
		011138	Drain Valve Adjustment Sleeve	1
		053649	Drain Valve Handle	1
		052653	Drain Valve Pull Rod	1
15		054428	Fitting 5/8 cc x 1/2"	1
16		054419	Hex Reducing Nipple	1
17		000611	Check Valve 2-way	1
18		007260	Fitting Compression Elbow	1
19		037537	Caster swivel, locking	2
20		037539	Caster, rigid	2

INCREDIBLE FRYING MACHINE® GAS FRYER REAR DRAIN - MODEL 2000

(corresponds with parts list on page 15)

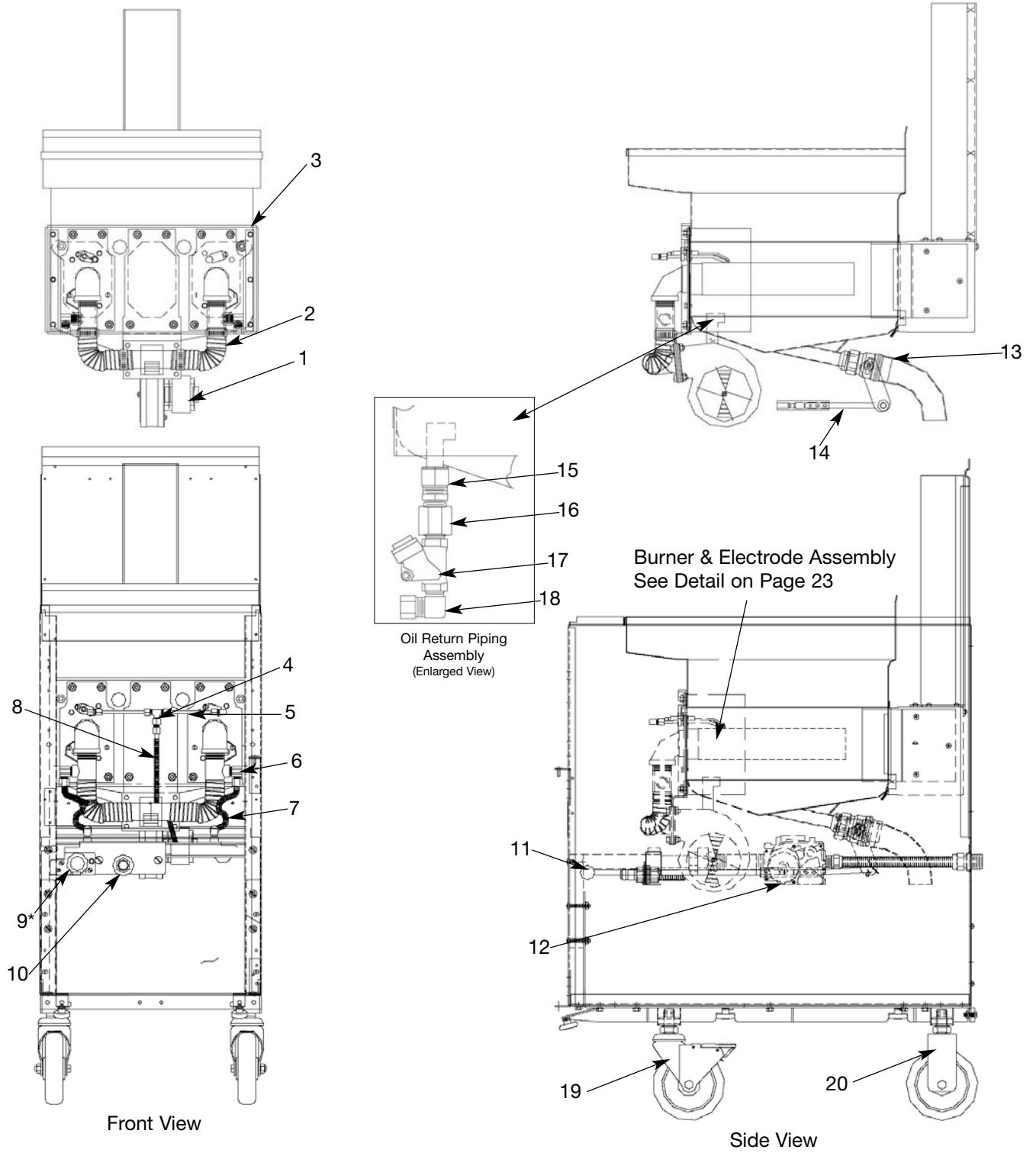

* Not shown
See pages 20-22 for Control Panel Parts List.

INCREDIBLE FRYING MACHINE® GAS FRYER PARTS LIST - MODEL 2006

ITEM	MODEL	PART NO.	DESCRIPTION	QTY
1	14"	030862	Blower	1
	18" & 20"	053726	Blower	1
2	ALL	057996	Air Hose 1.25" ID 9" long	2
	ALL	015393	Clamp 1/2" wide band 13/16 × 1 1/2"	2
3		Call 1-800-KEATING	Fry Pot	1
4	ALL	006474	Pilot Tee	
5	ALL	037549	Tubing S/S 3/16" × 1"	2
6	ALL	054205	Flex tubing 1/4" S/S 6" Long	1
7	ALL	037543	Fitting Compression 1/4" – 3/16 Reduction	2
8	ALL	054208	Flex tubing 1/4" S/S 15" Long	1
9	ALL	054512	Flex tubing 3/8" S/S 6" Long	2
	ALL	054426	Compression 3/8 × 1/8 90° Elbow	2
	ALL	015331	Tape 1/2" × .520 Teflon	A/R
10	ALL	024030	Gas Valve - Natural Gas	1
	ALL	024988	Gas Valve - LP	1
11	14"	004553	Drain Valve 1" Front	1
	18" & 20"	004554	Drain Valve 1 1/4" Front	1
12	ALL	037537	Caster - Swivel, Locking	2
13	ALL	037539	Caster - Rigid	2

INCREDIBLE FRYING MACHINE® GAS FRYER FRONT DRAIN - MODEL 2006

(corresponds with parts list on page 17)

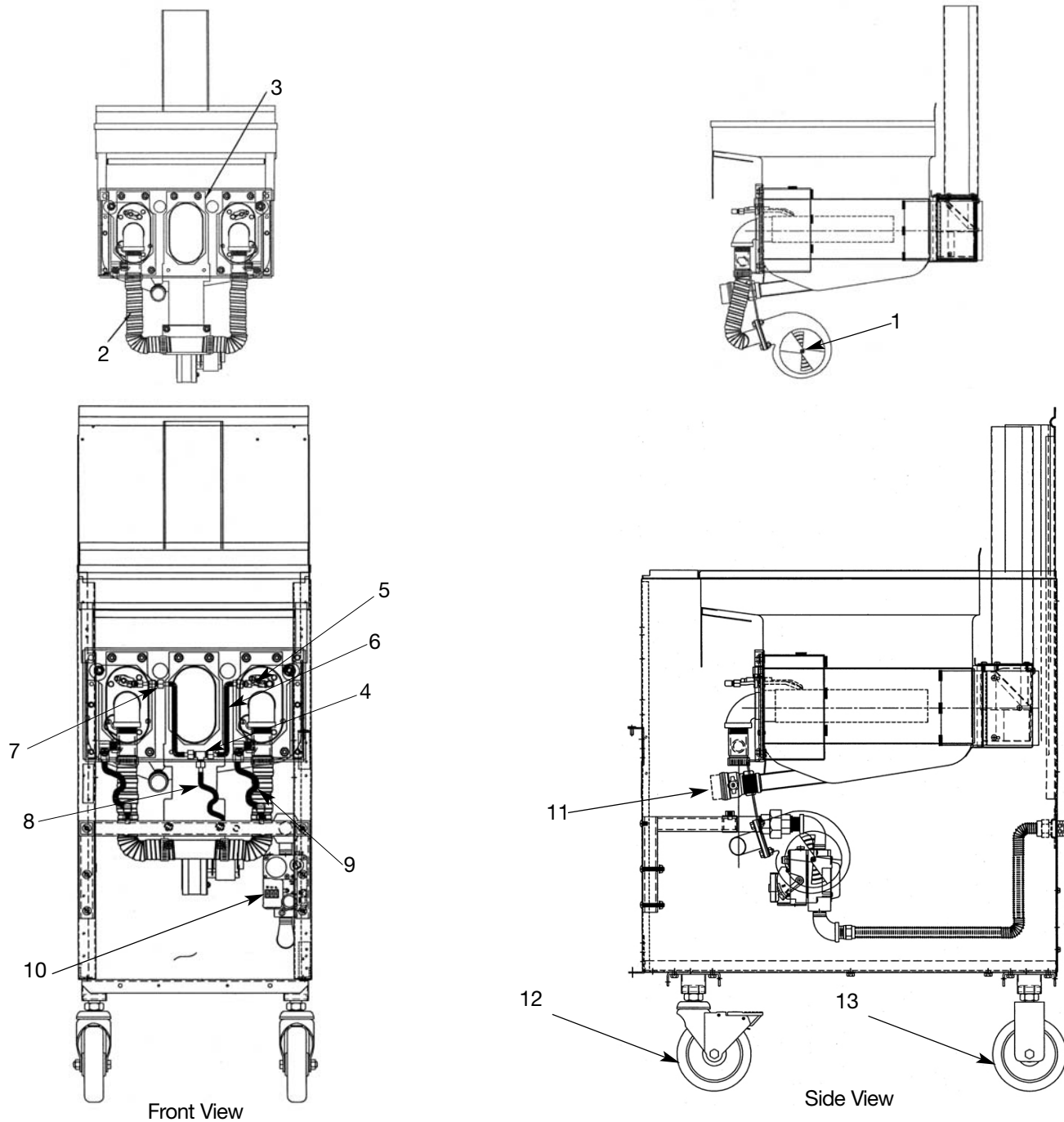

See pages 23-25 for Control Panel Parts List.

INCREDIBLE FRYING MACHINE® (IFM) GAS FRYER ASSEMBLY FRONT DRAIN
(FOR REFERENCE ONLY)

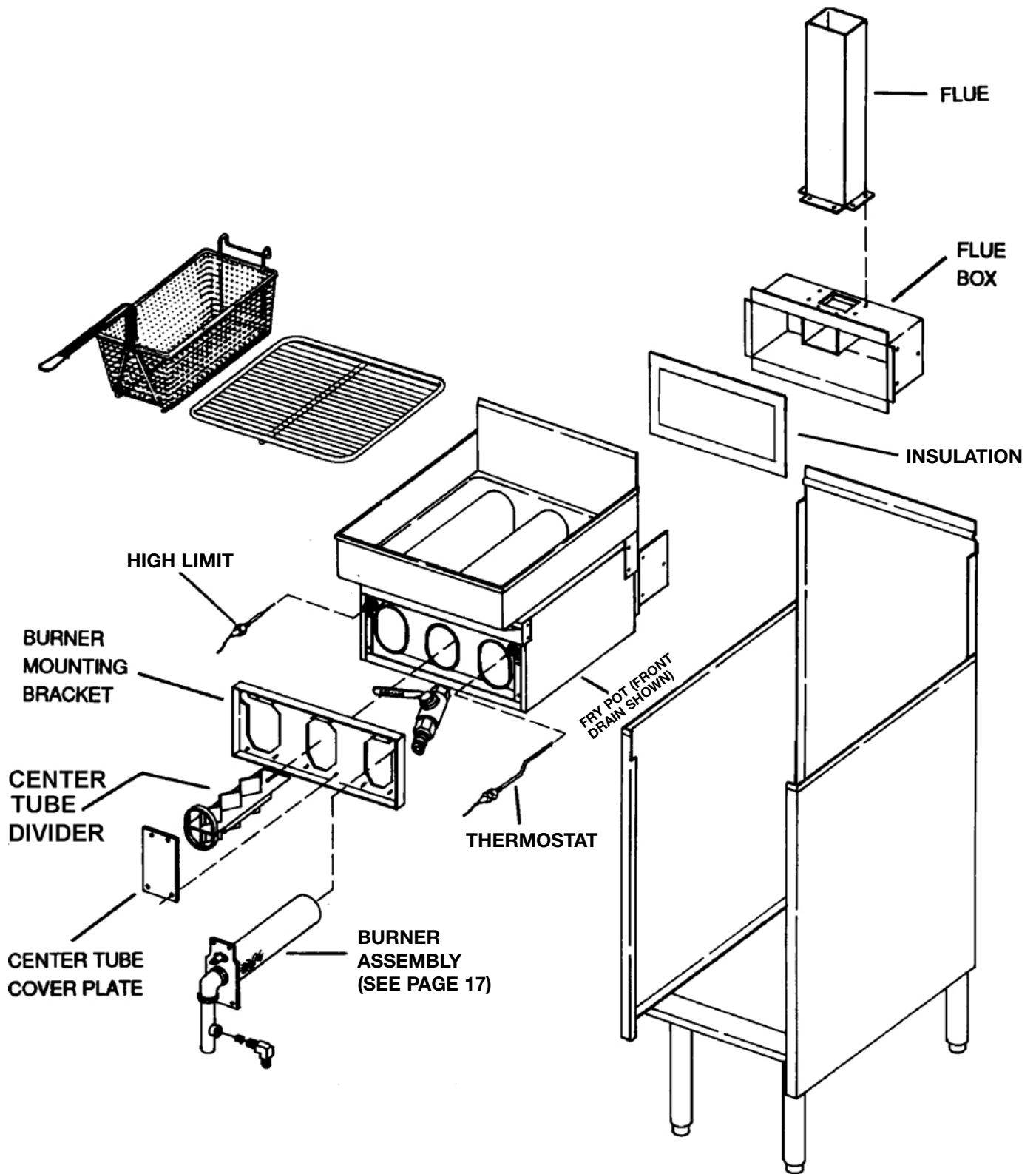

IFM CONTROL PANEL PARTS LIST (CONCEALED THERMOSTAT - NO TIMERS) MODEL 2000

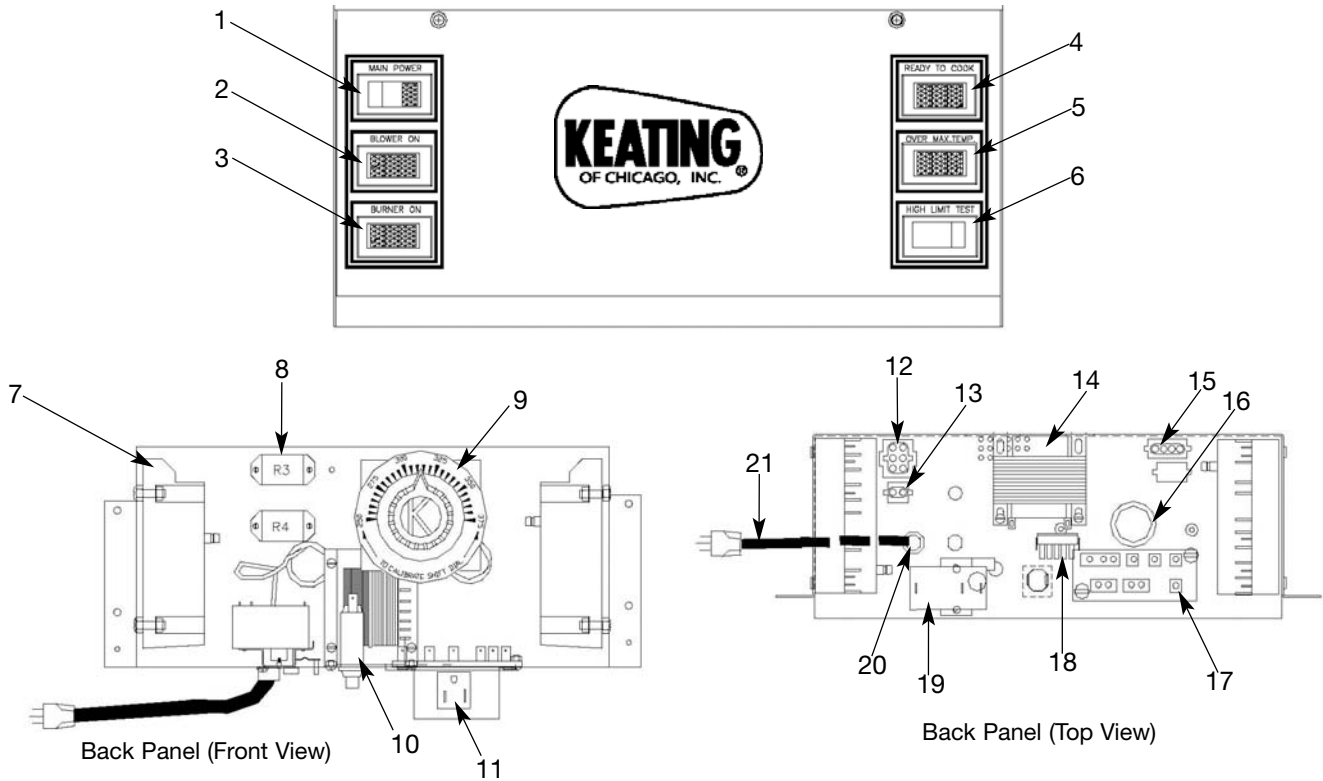

ITEM	DESCRIPTION	QTY	PART NUMBER
1	Power Switch with green Light	1	032242
	Power Switch without Light	1	035030
2	Indicating Light Blue	1	015120
3	Indicating Light Amber	1	021254
4	Indicating Light Green	1	021255
5	Indicating Light Red	1	021209
6*	High Limit Test Switch (Momentary)	1	015384
7	Spark Ignition Module	2	037550
	Spark Ignition Cable (Not Shown)	2	037551
8	Relay DPDT 24VAC	2	030844
9	Thermostat - 14" Model	1	035574
	Thermostat - 18" & 20" Models	1	035575
	Thermostat Dial Plate	1	058037
	Thermostat Knob	1	004163
10	Circuit Breaker	1	053338
11*	Receptacle Snap-In 125 VAC	1	011505
12	6 Circuit Quick Connect Female	1	028301
	Female Pins	6	028308
13	2 Circuit Quick Connect Female	1	032207
	Female Pins	6	028308
14	Transformer 120V-24V	1	024032
15	4 Circuit Quick Connect Female	1	032211
	Female Pins	6	028308
16	Snap-In Bushing 1"	3	005664
17	Terminal Board with Insulation	1	004153
18	12 Circuit Quick Connect Male	1	028306
	Male Pins	10	028309
19	High Limit (Resettable)	1	034357
20	Strain Relief Bushing	1	000430
21	Power Cord 120V 9ft.	1	006311

*Not available on all models

IFM CONTROL PANEL PARTS LIST (WITH TIMERS) MODEL 2000

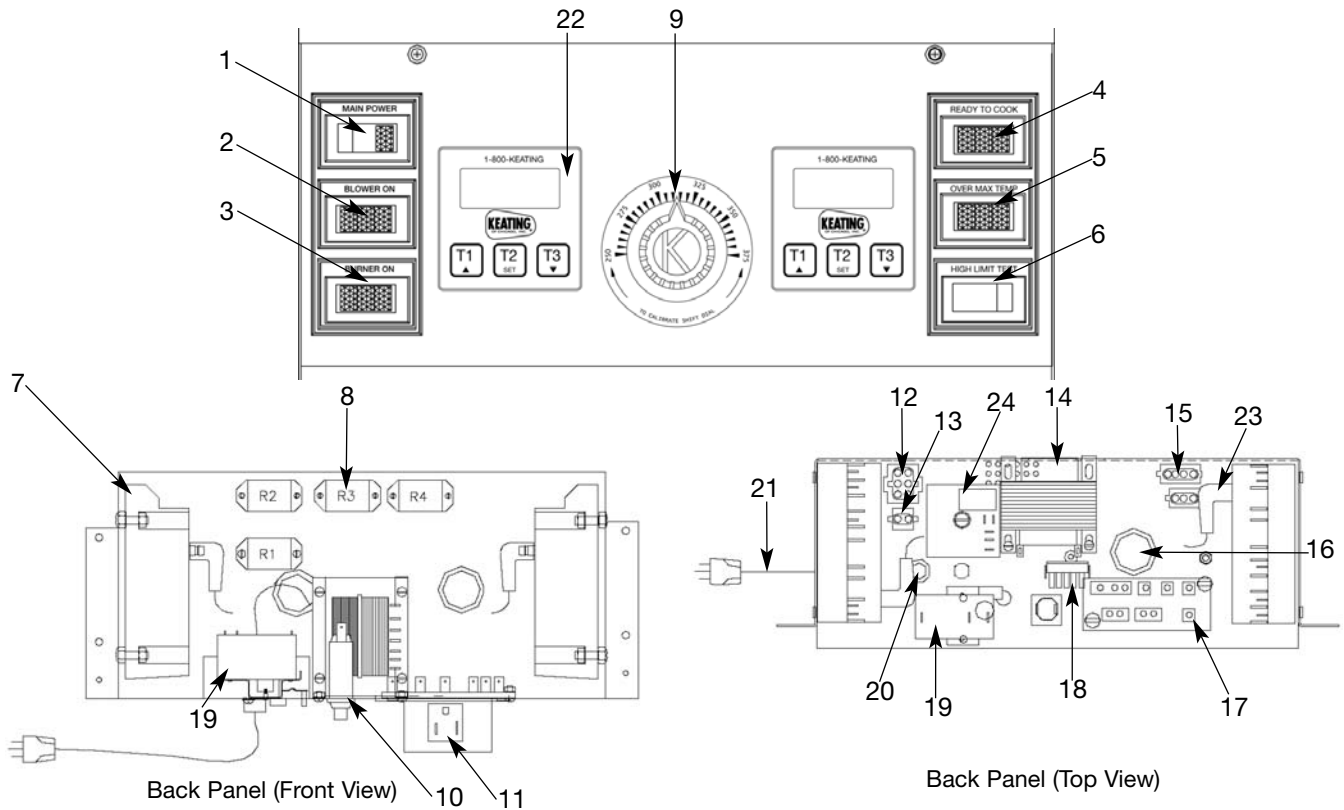

ITEM	DESCRIPTION	QTY	PART NUMBER
1	Power Switch with green Light	1	032242
	Power Switch without Light	1	035030
2	Indicating Light Blue	1	015120
3	Indicating Light Amber	1	021254
4	Indicating Light Green	1	021255
5	Indicating Light Red	1	021209
6*	High Limit Test Switch (Momentary)	1	015384
7	Spark Ignition Module	2	037550
8	Relay DPDT 24VAC	3	030844
9	Thermostat - 14" Model	1	035574
	Thermostat - 18" & 20" Models	1	035575
	Thermostat Dial Plate	1	058037
	Thermostat Knob	1	004163
10	Circuit Breaker	1	053338
11*	Receptacle Snap-In 125 VAC	1	011505
12	6 Circuit Quick Connect Female Female Pins	6	028301
		6	028308
13	2 Circuit Quick Connect Female Female Pins	1	032207
		6	028308
14	Transformer 120V-24V	1	024032
15	4 Circuit Quick Connect Female Female Pins	1	032211
		6	028308
16	Snap-In Bushing 1"	3	005664
17	Terminal Board with Insulation	1	004153
18	12 Circuit Quick Connect Male Male Pins	1	028306
		10	028309
19	High Limit (Resettable)	1	032243
20	Strain Relief Bushing	1	000430
21	Power Cord 120V 9ft.	1	006311
22	Timer	2	056921
23	Spark Ignition Cables	2	037551
24	Relay 35 Seconds	1	030845

*Not available on all models

IFM CONTROL PANEL PARTS LIST MODEL 2006 CPU

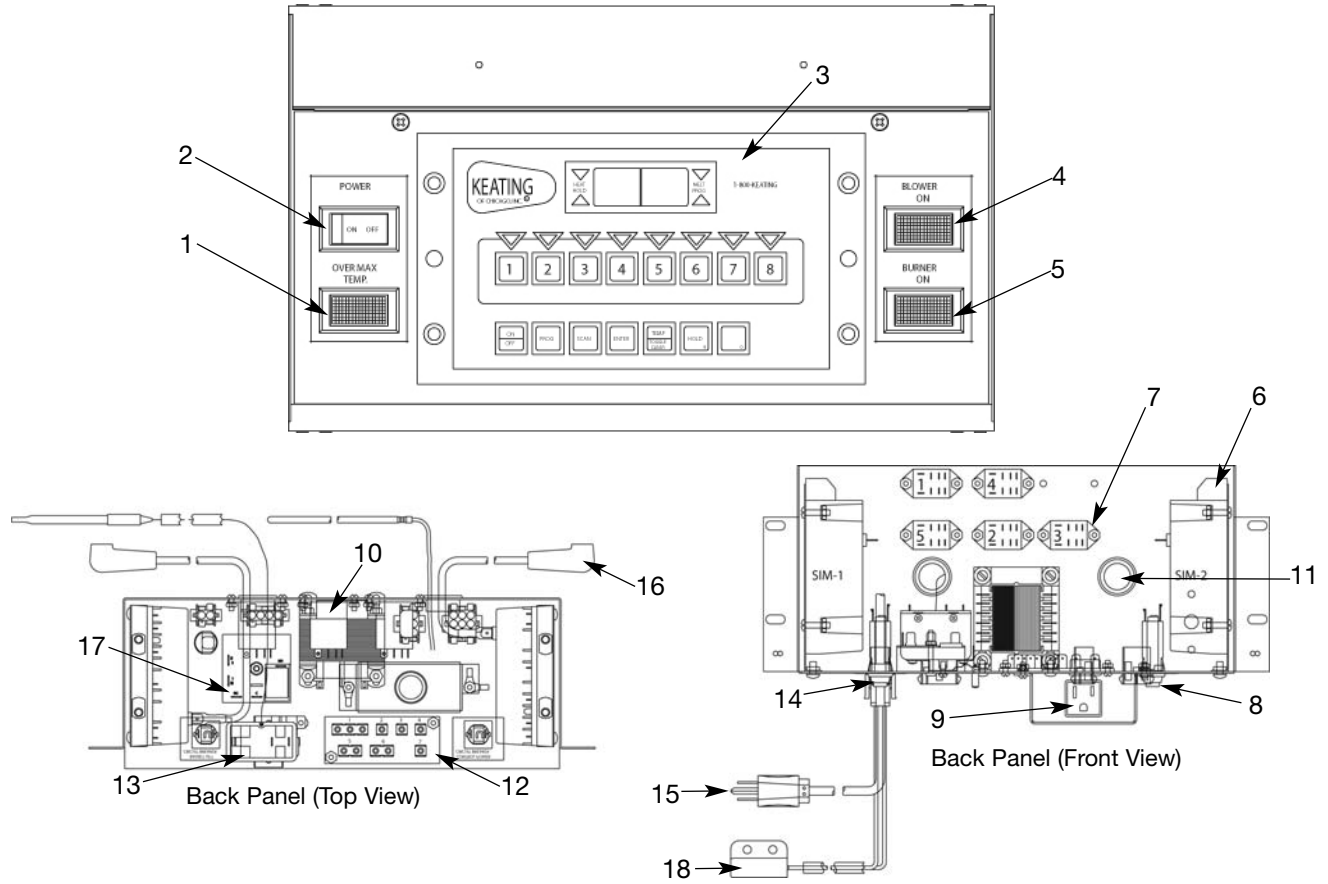

ITEM	DESCRIPTION	QTY	PART NUMBER
1	Indicating Light Red Rectangular 28V	1	021209
2	Switch Rocker On / Off DPST	1	035030
3	Computer	1	031125
	Computer probe only (not shown)	1	004776
4	Indicating Light Blue Rectangular 28V	1	032828
5	Indicating Light Amber Rectangular 28V	1	021254
6	Spark Ignition Module	2	037550
7	Relay DPDT 24VAC	5	030844
8	Circuit Breaker	1	053338
9	Receptacle Snap-In 125 VAC	1	011505
10	Transformer 120V-24V	1	024032
11	Snap-In Bushing 1"	3	005664
12	Terminal Board with Insulation	1	004153
13	High Limit (Resettable)	1	034357
14	Strain Relief Bushing	1	000430
15	Power Cord 120V 9ft.	1	006311
16	Spark Ignition Cables	2	037551
17	Relay 35 Seconds	1	058684
18*	Safety Switch Magnetic Reed	1	053777

*Not available on all models

BOB EVANS IFM CONTROL PANEL PARTS LIST(FRONT/REAR DRAIN - CONCEALED THERMOSTAT - NO TIMERS) MODEL 2006

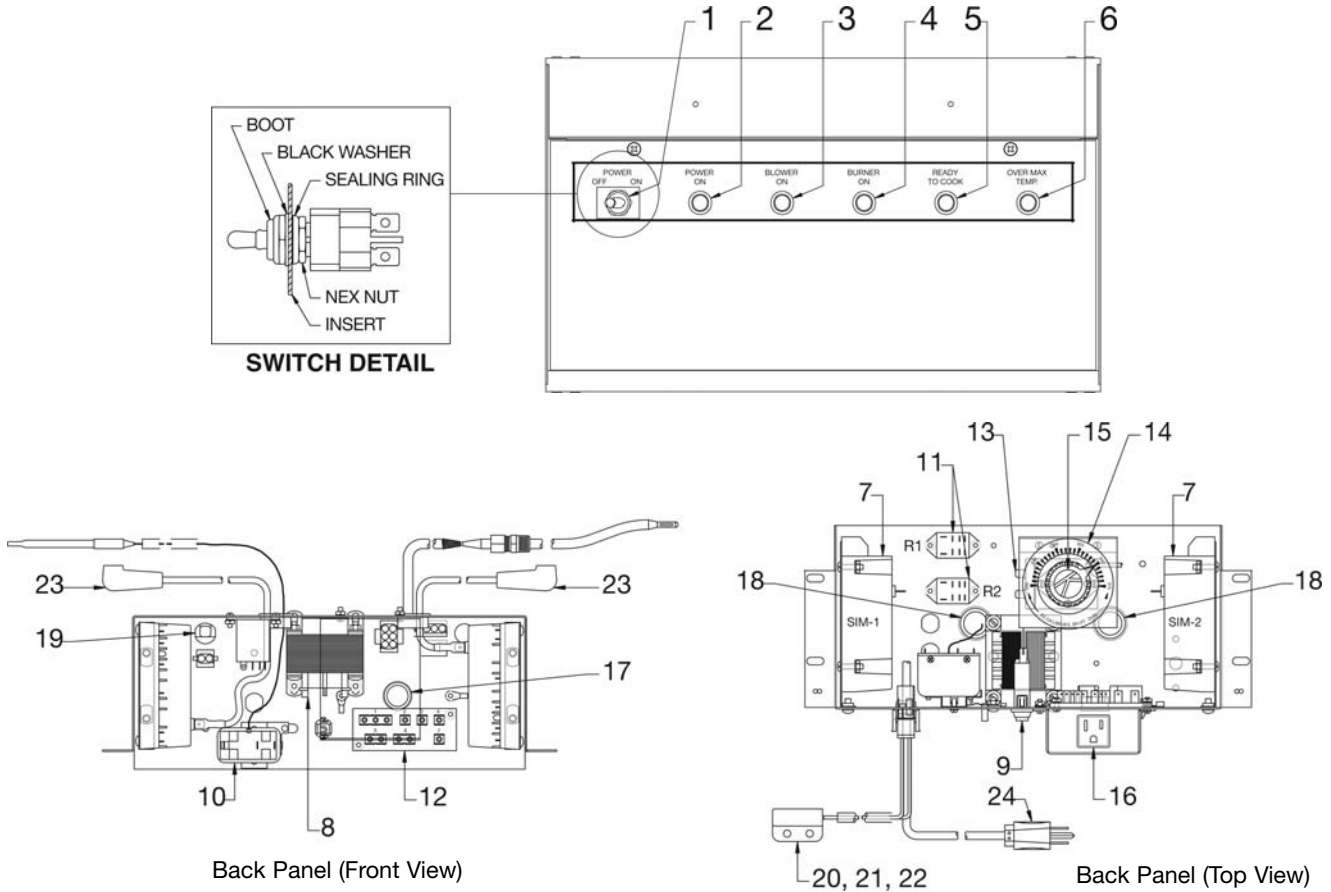

ITEM	DESCRIPTION	QTY	PART NUMBER
1	Switch Toggle Sealed On-Off	1	056056
2	Indicating Light Clear Round 28V	1	057863
3	Indicating Light Blue Round 28V	1	057862
4	Indicating Light Amber Round 28V	1	056588
5	Indicating Light Green Round 28V	1	056587
6	Indicating Light Red Round 28V	1	057861
7	Spark Ignition module IFM 24VAC	2	037550
8	Transformer Stepdown 24VAC 80VA	1	024032
9	Circuit Breaker 3 AMP 1 POLE 250V	1	053338
10	High limit Manual Reset	1	034357
11	Relay DPDT 24VAC	2	030844
12	Terminal Board with Insulation	1	004153
13	Thermostat - 14" Model	1	035574
	Thermostat - 18" & 20" Models	1	035575
14	Thermostat Dial Plate 375°	1	058037
15	Thermostat Knob	1	004163
16*	Receptacle 125V 15A Snap-In	1	011505
17	Bushing - Black Plastic Snap-In 7/8"	1	000514
18	Bushing - Black Plastic Snap-In 1"	2	005664
19	Bushing Strain Relief	1	000470
20*	Switch Magnetic Safety N.C.	1	053777
21	Connector 2 Circuit Quick Plug	1	032208
22	Connector Contact Pin Male	2	032208
23	Spark Ignition Electrode Lead 24"	2	037551
24	Power Cord 9' 120V	1	006311

*LOCATED ON REAR DRAIN UNITS ONLY

IFM CONTROL PANEL PARTS LIST(FRONT DRAIN WITH TIMERS) MODEL 2006 - 14" SIZE

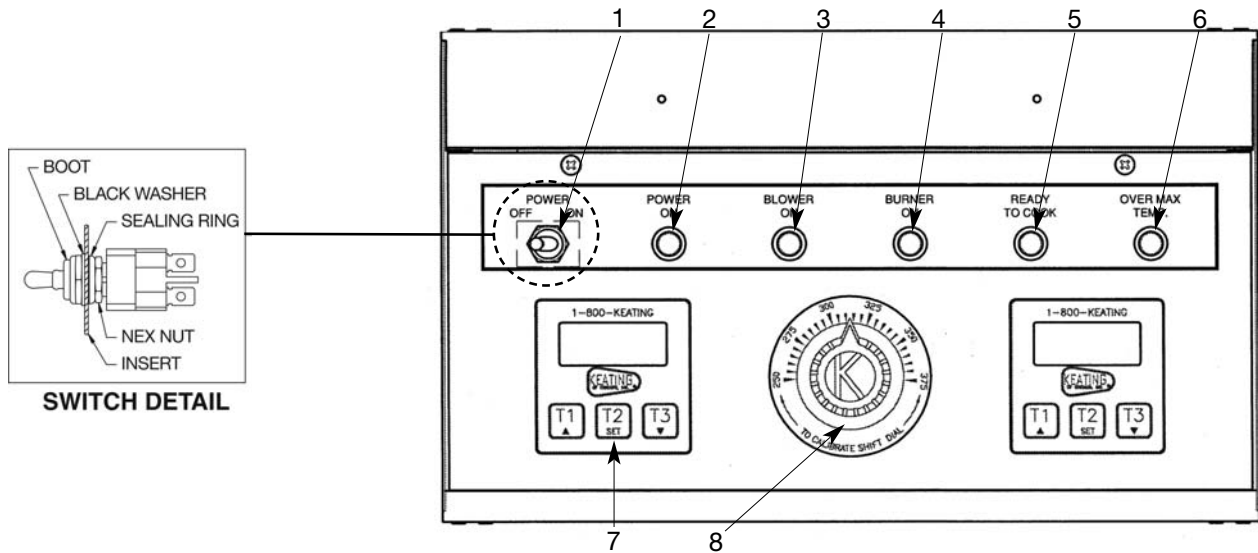

Back Panel (Front View)

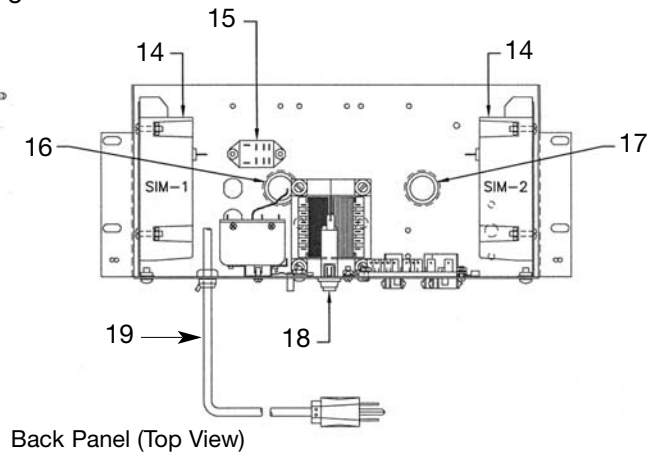
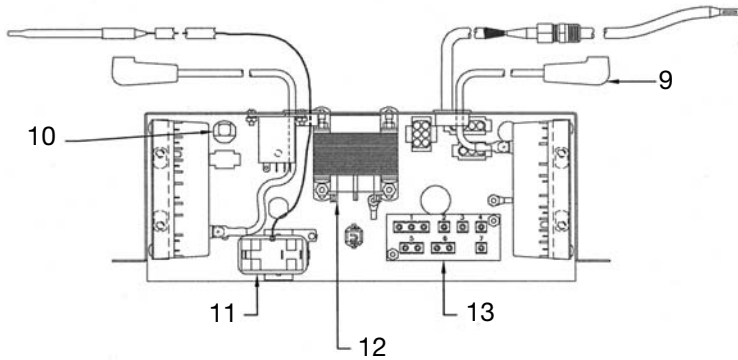

Back Panel (Top View)

ITEM	DESCRIPTION	QTY	PART NUMBER
1	Switch Toggle Sealed On-Off	1	056056
2	Indicating Light Clear Roundt 28V	1	057863
3	Indicating Light Blue Round 28V	1	057862
4	Indicating Light Amber Round 28V	1	056588
5	Indicating Light Green Round 28V	1	056587
6	Indicating Light Red Round 28V	1	057861
7	Timer Digital 24/120V	2	056921
8	Thermostat Knob	1	004163
	Thermostat Dial Plate	1	058037
	Thermostat - 14" Model	1	035574
	Thermostat - 18" & 20" Models	1	035575
9	Spark Ignition Electrode Lead 24"	2	037551
10	Bushing Strain Relief	1	000470
11	High Limit Manual Reset	1	034357
12	Transformer Stepdown 24VAC 80VA	1	024032
13	Terminal Board with Insulation	1	004153
14	Spark Ignition Module IFM 24VAC	1	037550
15	Relay DPDT 24VAC	1	030844
16	Black Plastic Snap-In Bushing 1"	1	005664
17	Black Plastic Snap-In Bushing 1"	1	005664
18	Circuit Breaker, 3 AMP 1 POLE 250V	1	053338
19	Power Cord 9' 120V	1	006311

IFM CONTROL PANEL PARTS LIST(FRONT DRAIN WITH TIMERS) MODEL 2007 - 18" & 20" SIZE

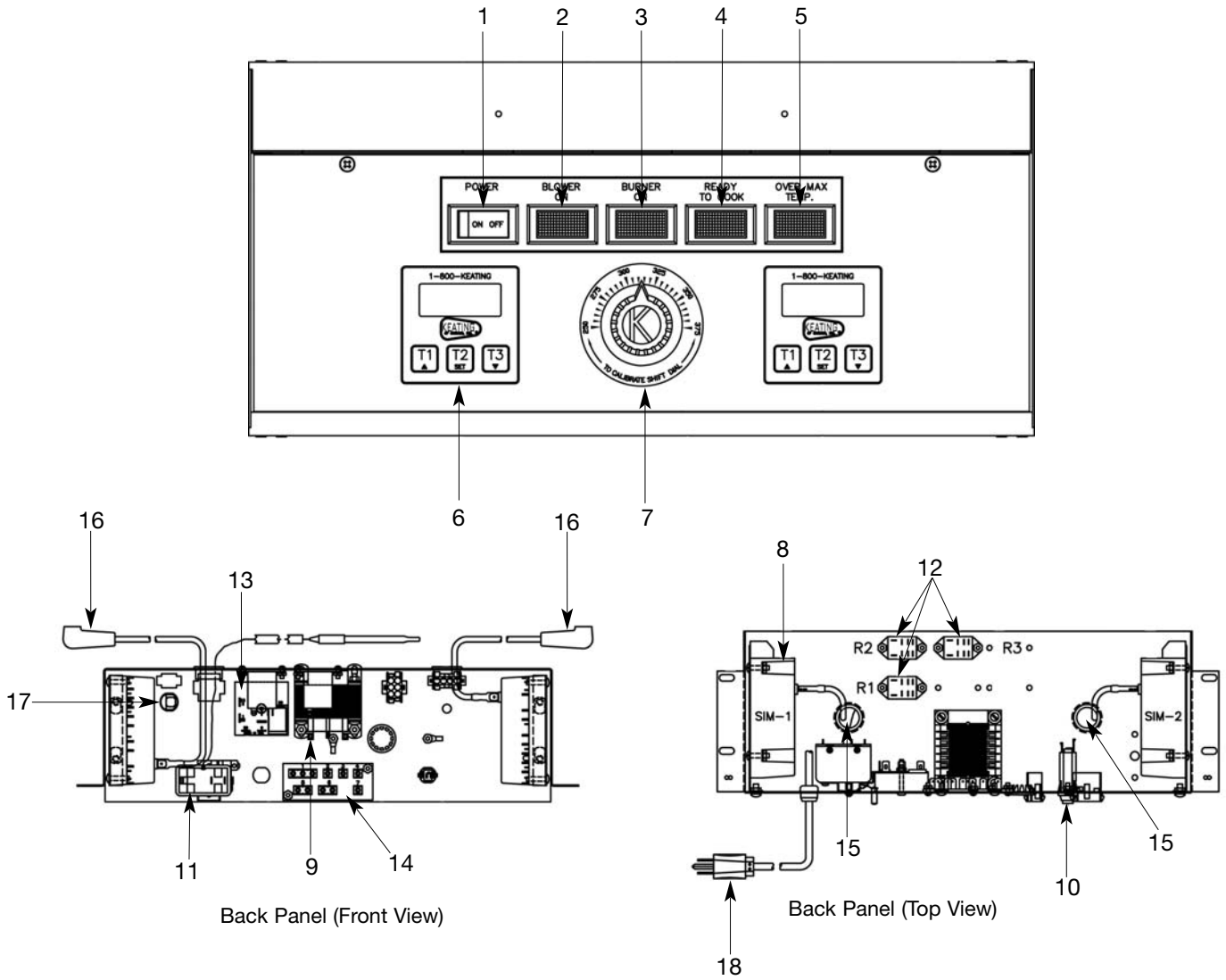

ITEM	DESCRIPTION	QTY	PART NUMBER
1	Switch Rocker On / Off DPST	1	035030
2	Indicating Light Blue Rectangular 28V	1	032828
3	Indicating Light Amber Rectangular 28V	1	021254
4	Indicating Light Green Rectangular 28V	1	021255
5	Indicating Light Red Rectangular 28V	1	021209
6	Timer Digital 24/120V	2	056921
7	Thermostat	2	035575
	Thermostat Dial Plate 250-375°	1	058037
	Thermostat Knob	1	004163
8	Spark Ignition module IFM 24VAC	2	037550
9	Transformer Stepdown 24VAC 80VA	1	024032
10	Circuit Breaker 3 AMP 1 POLE 250V	1	053338
11	High limit Manual Reset	1	034357
12	Relay DPDT 24VAC	3	030844
13	Relay 35 Seconds	1	058684
14	Terminal Board with Insulation	1	004153
15	Bushing - Black Plastic Snap-In 1"	2	005664
16	Spark Ignition Electrode Lead 24"	2	059303
17	Bushing Strain Relief	1	000470
18	Power Cord 9' 120V	1	006311

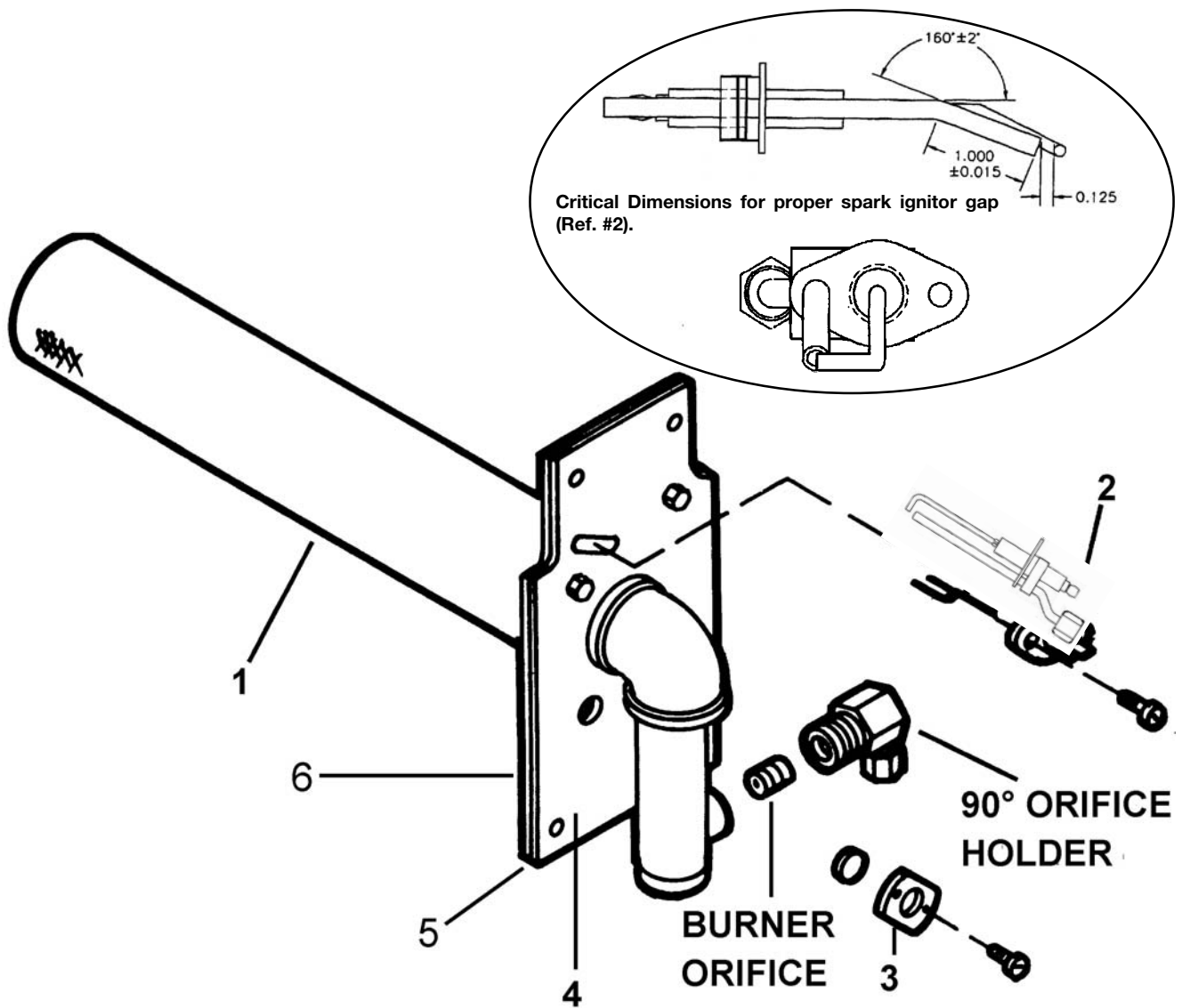
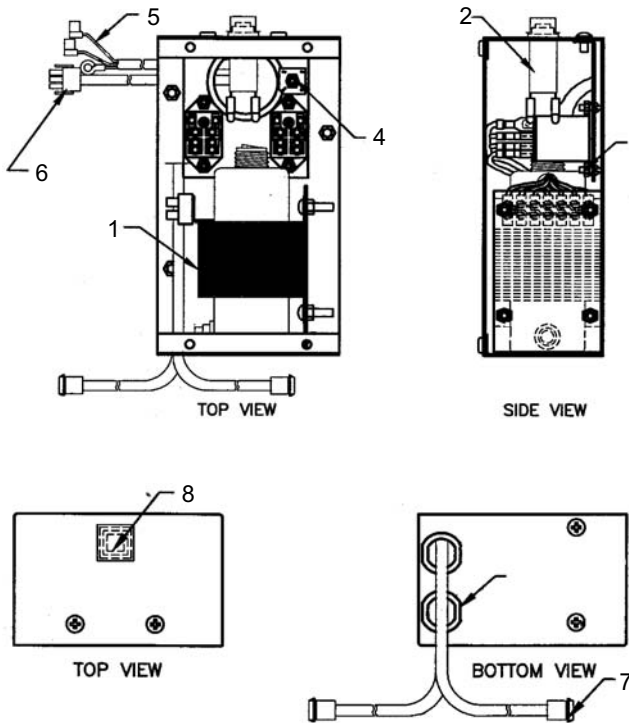

Figure 7-2 IFM Burner Assembly (Right Side Shown)

ITEM	DESCRIPTION	QTY	PART NUMBER
1	BURNER REPLACEMENT KIT (BURNER WITH ITEMS 5 & 6)	1	016506
2	SPARK ELECTRODE REPLACEMENT KIT NATURAL GAS LP GAS	1	052562 052908
3	OBSERVATION WINDOW ASSEMBLY LENS COVER	1	016101 015905
4	BURNER OUTER PLATE & ELBOW ASSEMBLY (LEFT OR RIGHT SIDE)	1	022158
5	BURNER TO PLATE SEALING GASKET	1	016505
6	BURNER TO TUBE SEALING GASKET	2	016504

Basket Lift Power Supply Box



Basket Lift Assembly

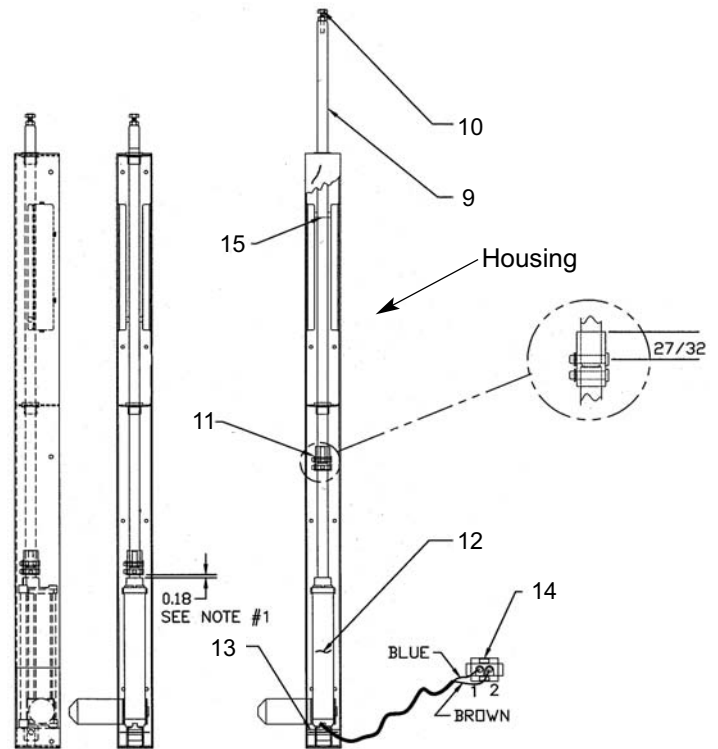

NOTES

1. A minimum distance of $\frac{3}{16}$ " and maximum distance of $\frac{1}{4}$ " should be maintained when actuator is at full downward stroke. Item 11 should never be bottomed on item 12 when in this location.
2. Actuator shaft should travel $6\frac{1}{2}$ " upward from lowest position.
3. Distances are to be measured when actuator is powered.
4. Apply light coating of food grade grease to Item 9 on entire shaft inside housing.

DESCRIPTION	QTY	PART #
1 TRANSFORMER 120/208/240/480V	1	056036
2* CIRCUIT BREAKER 3A/250V	1	053338
3 RELAY DPDT 24V AC	2	030844
4 RECTIFIER	1	018321
5 POWER CORD	1	021289
6 CONNECTION 3 CIRCUITS PLUG	1	032210
7 CONNECTOR 2 CIRCUIT CAP	2	032207
8 COVER FOR CIRCUIT BREAKER	1	054664
9 PUSH ROD	1	018096
10 SCREW $\frac{1}{4}$ "-20" X $1\frac{1}{4}$ "	1	021091
HEX NUT $\frac{1}{4}$ -20	1	016383
11 COUPLER ACTUATOR BL	1	054525
RETAINING RING	2	054540
PIN COUPLER ACTUATOR BL	2	054503
12 ACTUATOR 24V DC	1	054510
13 SHAFT ACTUATOR LOWER BL S/S	1	054522
14 CONNECTOR 2 CIRCUIT QUICK	1	032208
CONNECTOR CONTACT PIN MALE	2	028309
15 PIN BASKET LIFT NON ROTATIONAL	1	054760

*This circuit breaker can be found under the control panel on newer units.

WIRING DIAGRAMS

NOTE: A separate wiring diagram has been included with this manual and should be saved for troubleshooting and maintaining the fryer. The wiring diagrams in this section cover standard fryers which may or may not match the diagram sent with the fryer. Non-standard fryers such as CPU models, etc., do not have wiring diagrams printed in this section.

Single Basket Lift Power Supply Box

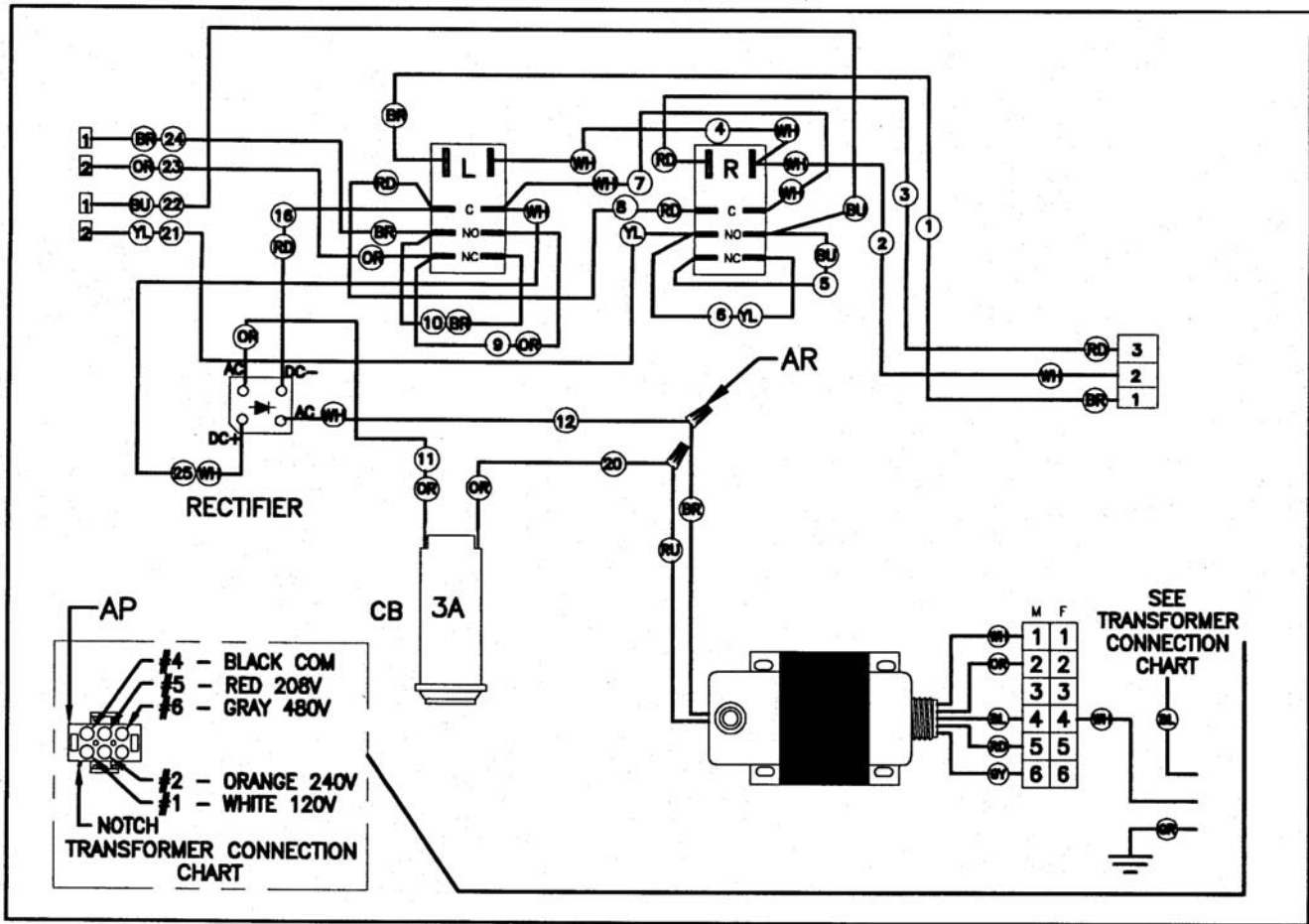

NOTES:

1. Wire Material: See wires



specification

2. Remove 3/8" of insulation from end of wire

3. Route all wires so they lay flat and are organized in appearance.

4. Tug test all wires connect-

14 IFM 120V CONNECTION DIAGRAM - NO TIMERS, FRONT DRAIN - MODEL 2000

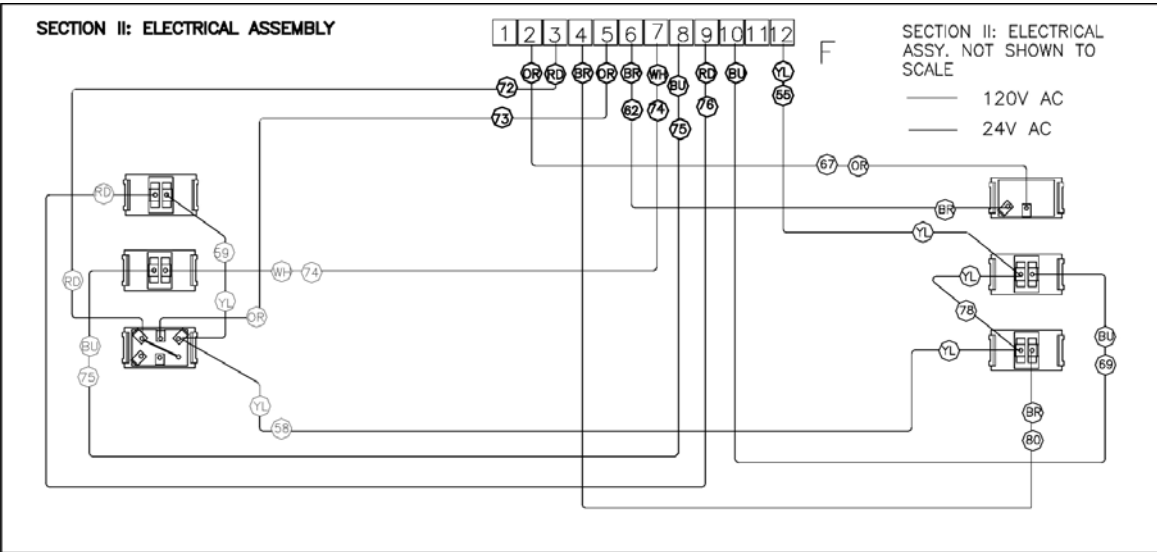

CONTROL PANEL INSERT

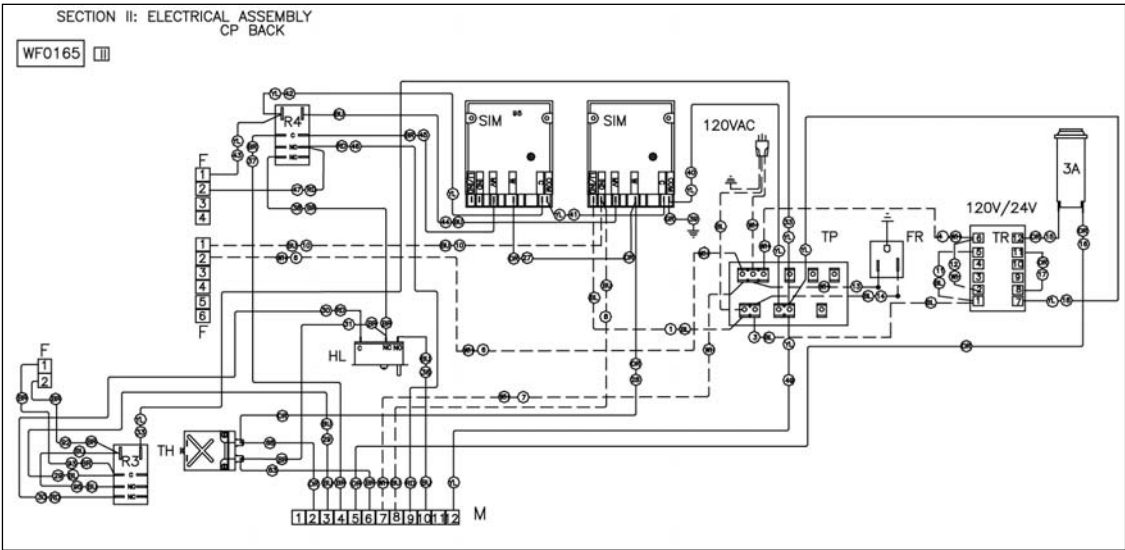

CONTROL PANEL BACK

**IFM - 120V CONNECTION DIAGRAM - TIMERS, FRONT DRAIN
WITH LIGHTED ROCKER SWITCH - MODEL 2000**

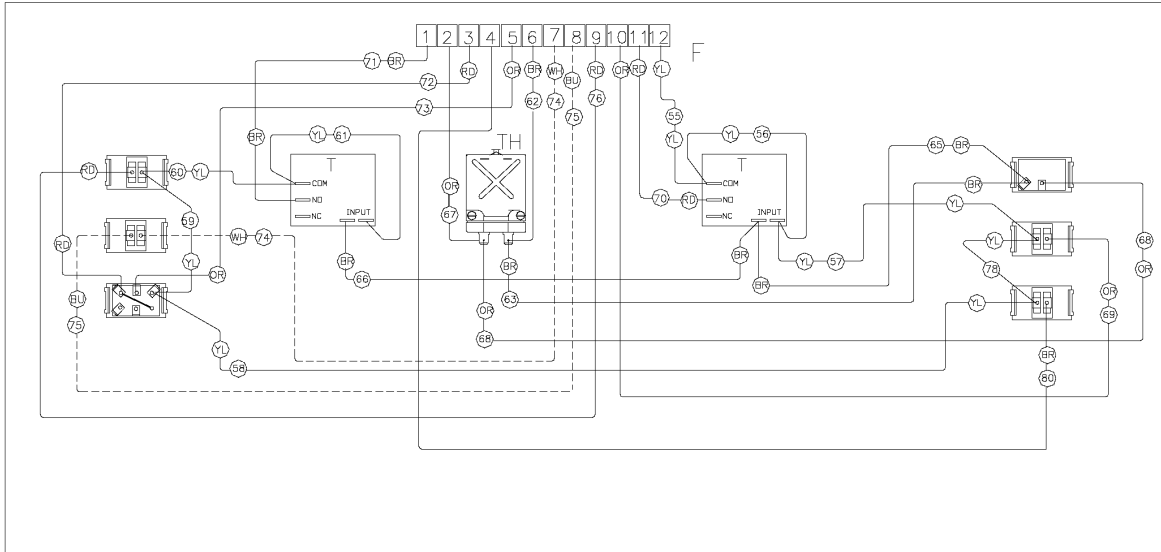

CONTROL PANEL INSERT

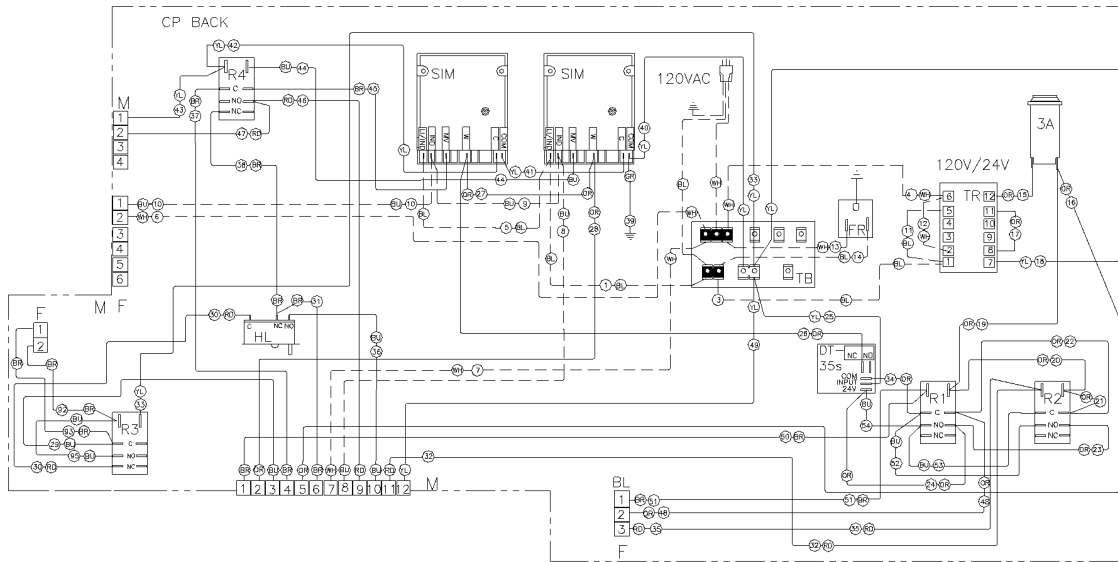

CONTROL PANEL BACK

14 IFM - MODEL 2006 FRONT DRAIN WITHOUT LIGHTED ROCKER SWITCH

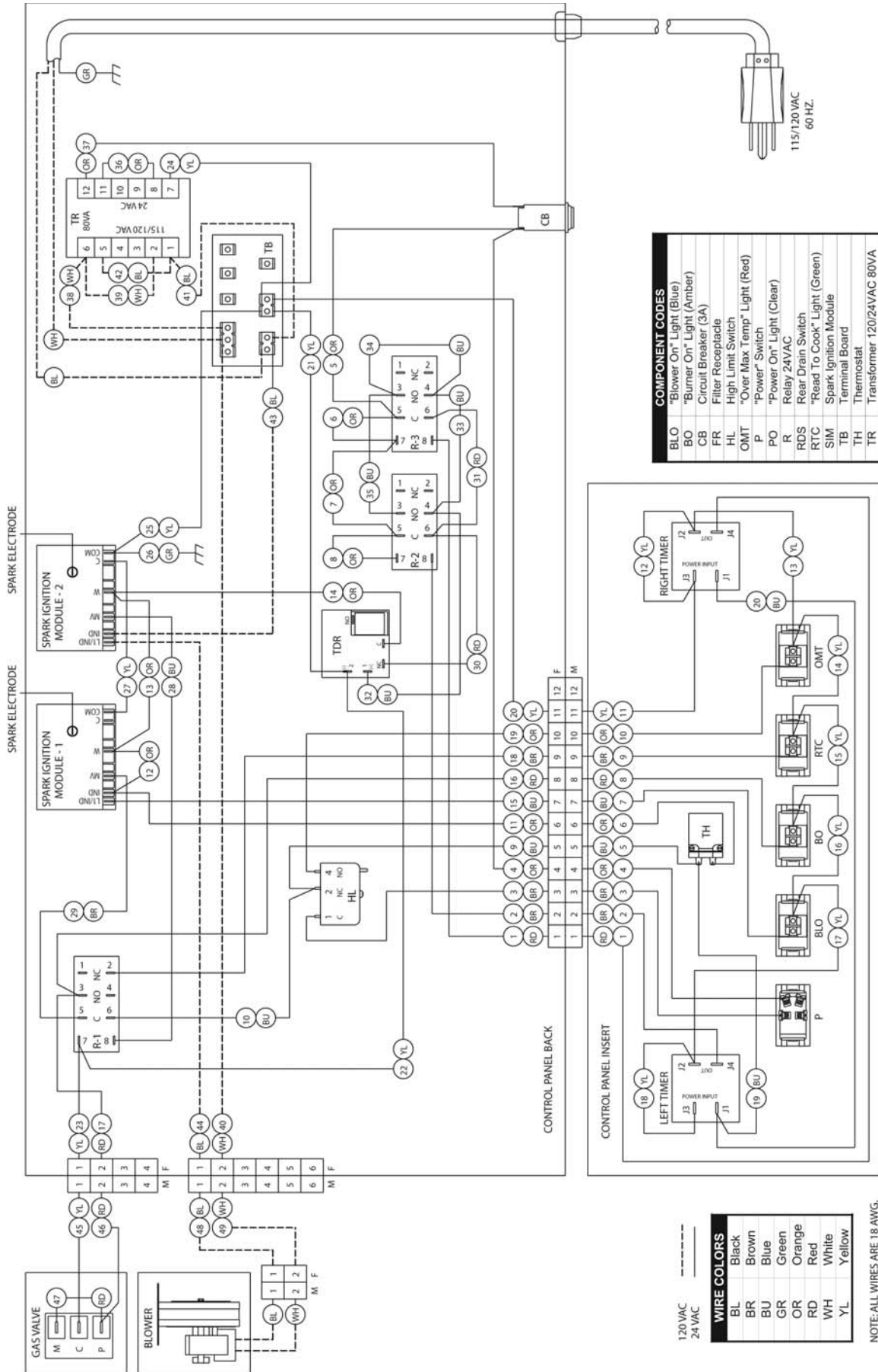

14 IFM - MODEL 2006 WITH SAFE AND EASY® FILTER

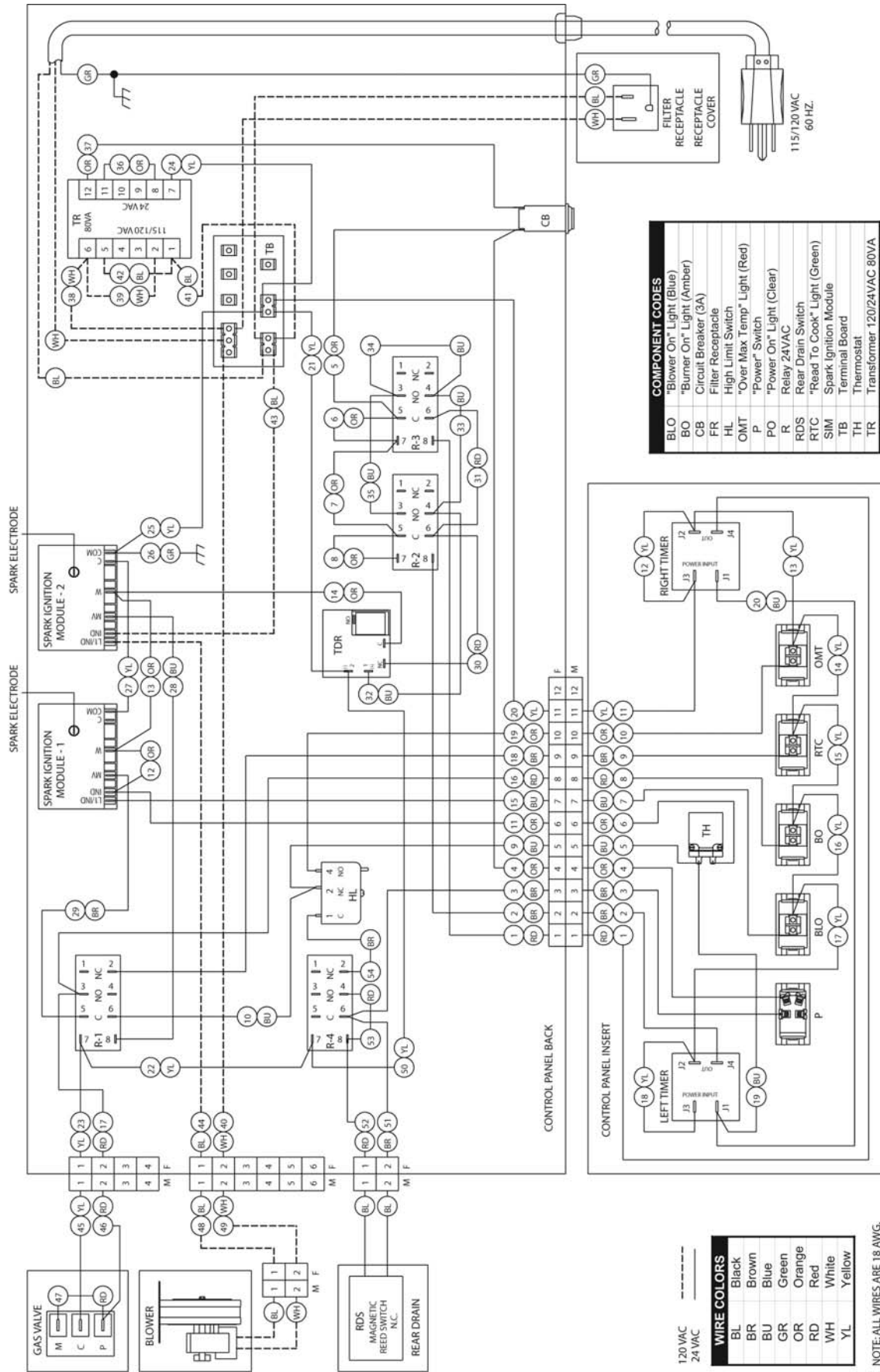

COMPONENT CODES	
BLO	"Blower On" Light (Blue)
BO	"Burner On" Light (Amber)
CB	Circuit Breaker (3A)
FR	Filter Receptacle
HL	High Limit Switch
OMT	"Over Max Temp" Light (Red)
P	"Power" Switch
PO	"Power On" Light (Clean)
R	Relay 24VAC
RDS	Rear Drain Switch
RTC	"Read To Cook" Light (Green)
SIM	Spark Ignition Module
TB	Terminal Board
TH	Thermostat
TR	Transformer 120/24VAC 80VA

WIRE COLORS	
BL	Black
BR	Brown
BU	Blue
GR	Green
OR	Orange
RD	Red
WH	White
YL	Yellow

NOTE: ALL WIRES ARE 18 AWG.

14 IFM - MODEL 2006 CPU BASKET LIFT FRONT DRAIN

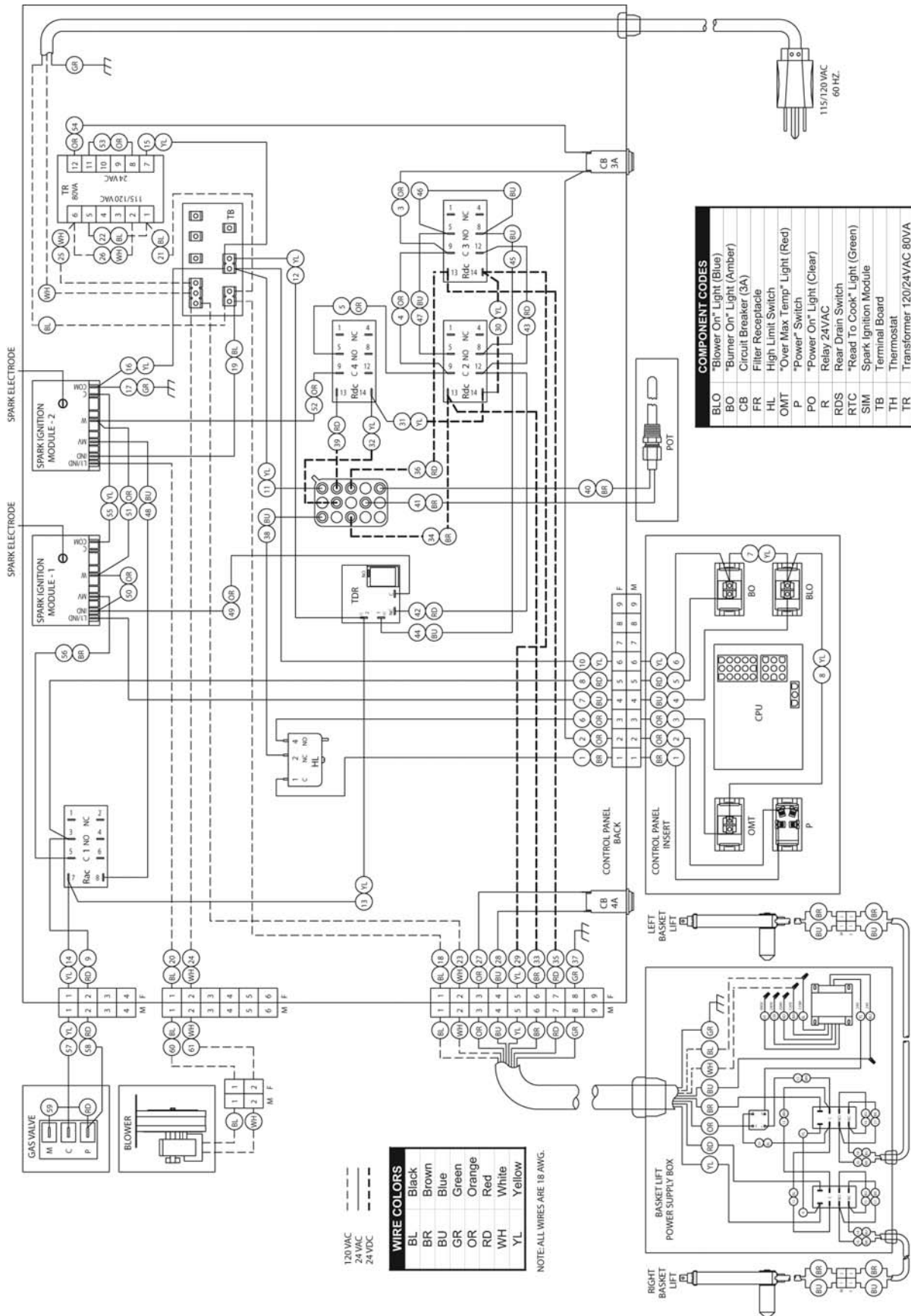

--- 120 VAC
 - - - 24 VAC
 - · - 24 VDC

WIRE COLORS

BL	Black
BR	Brown
BU	Blue
GR	Green
OR	Orange
RD	Red
WH	White
YL	Yellow

NOTE: ALL WIRES ARE 18 AWG.

COMPONENT CODES

BLO	"Blower On" Light (Blue)
BO	"Burner On" Light (Amber)
CB	Circuit Breaker (3A)
FR	Filter Receptacle
HL	High Limit Switch
OMT	"Over Max Temp" Light (Red)
P	"Power" Switch
PO	"Power On" Light (Clear)
R	Relay 24VAC
RDS	Rear Drain Switch
RTC	"Read To Cook" Light (Green)
SIM	Spark Ignition Module
TB	Terminal Board
TH	Thermostat
TR	Transformer 120/24VAC 80VA

18 & 20 IFM - MODEL 2006 FRONT DRAIN WITH LIGHTED ROCKER SWITCH

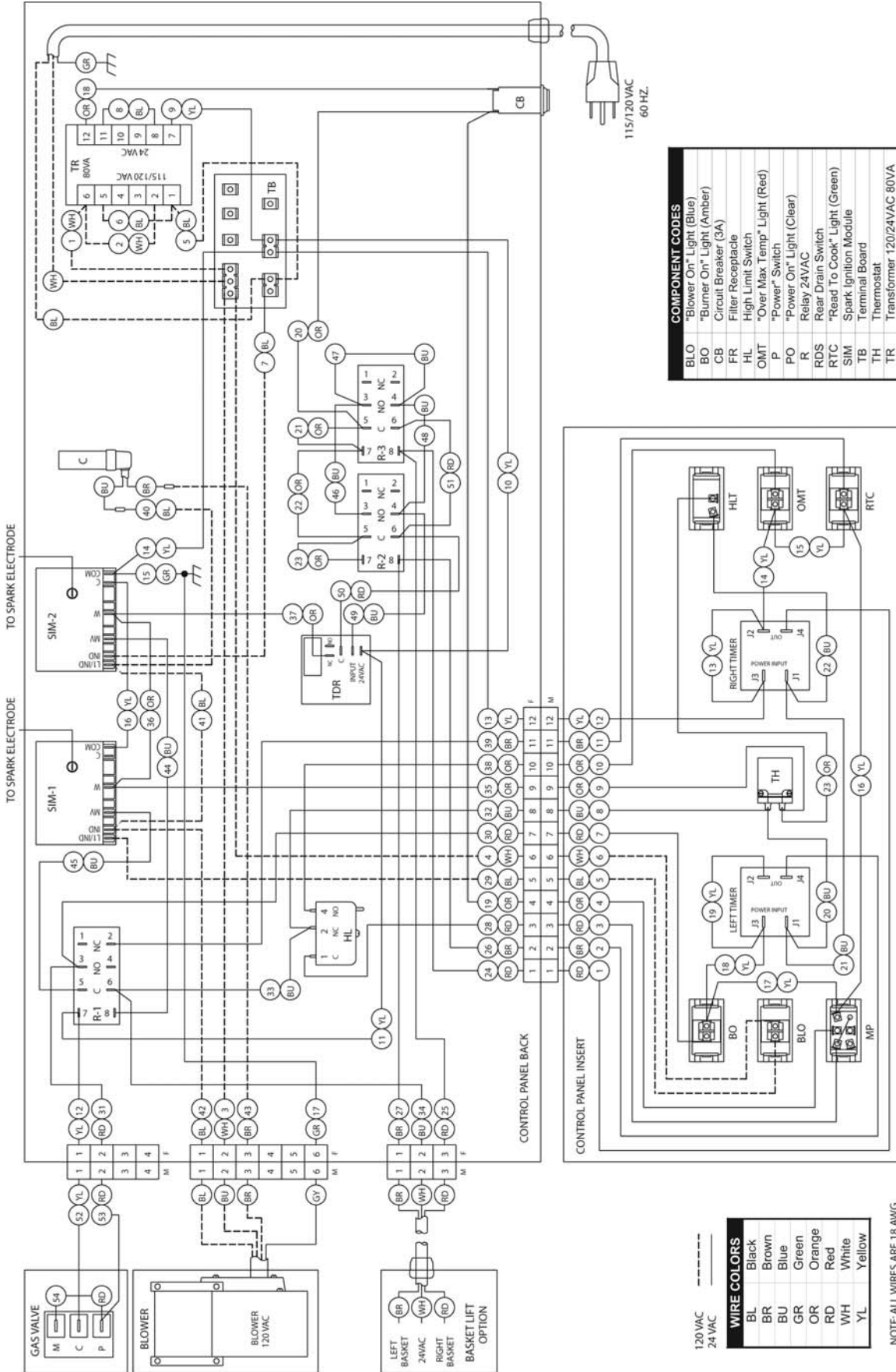

18 & 20 IFM - MODEL 2007 FRONT DRAIN WITHOUT LIGHTED ROCKER SWITCH

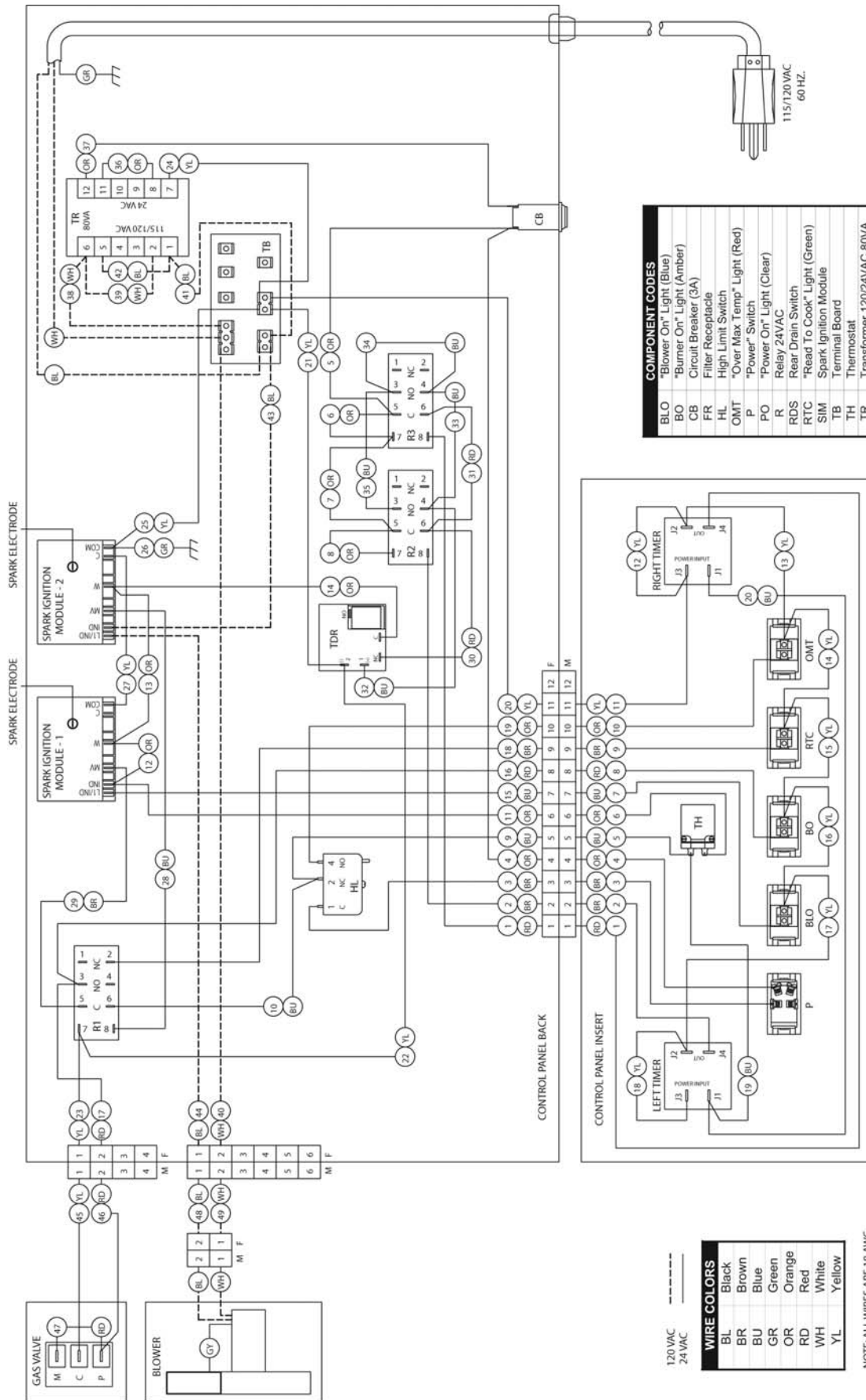

18 & 20 IFM - MODEL 2007 REAR DRAIN WITHOUT LIGHTED ROCKER SWITCH

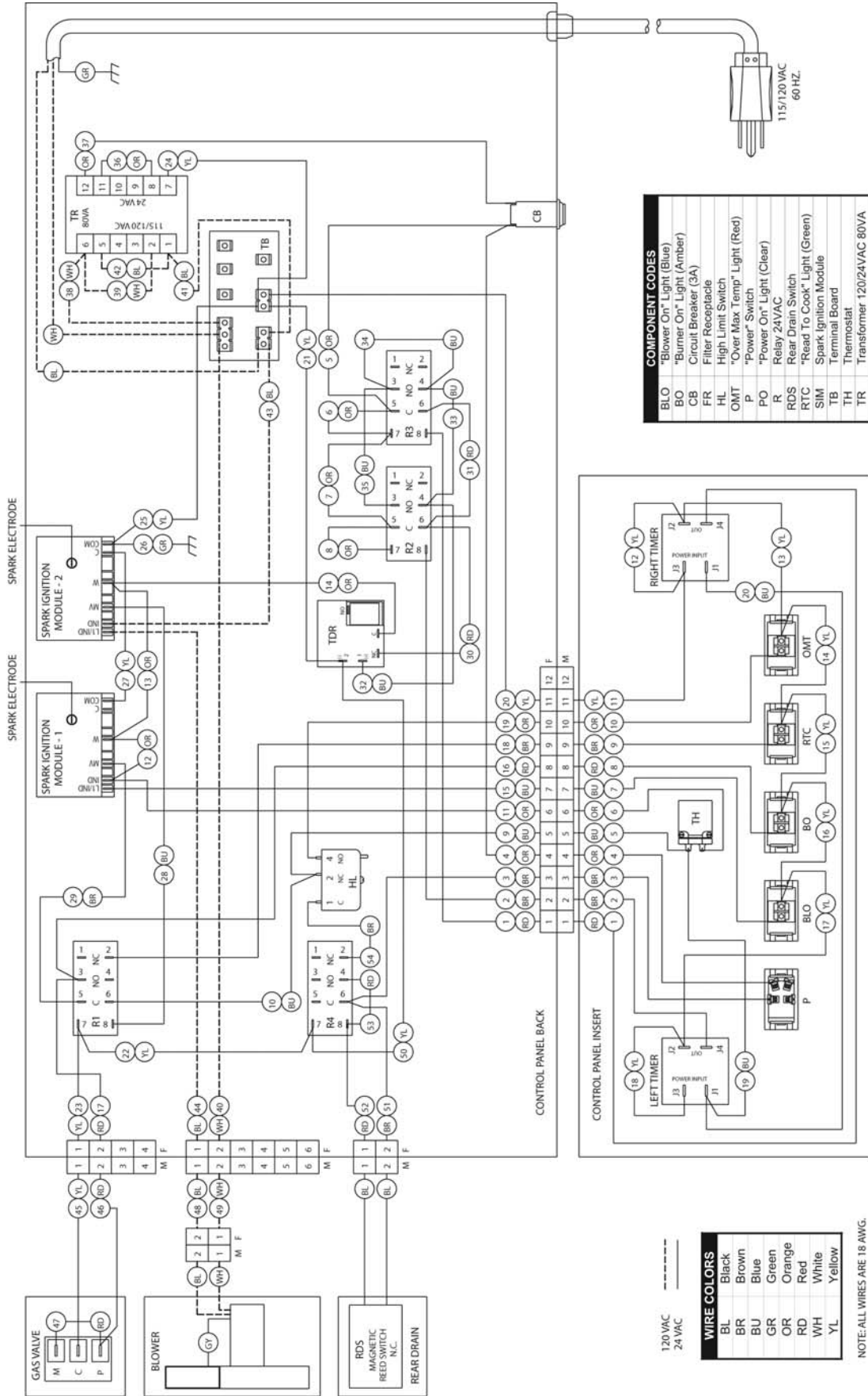

18 & 20 IFM - MODEL 2007 WITH SAFE AND EASY[®] FILTER WITHOUT LIGHTED ROCKER SWITCH

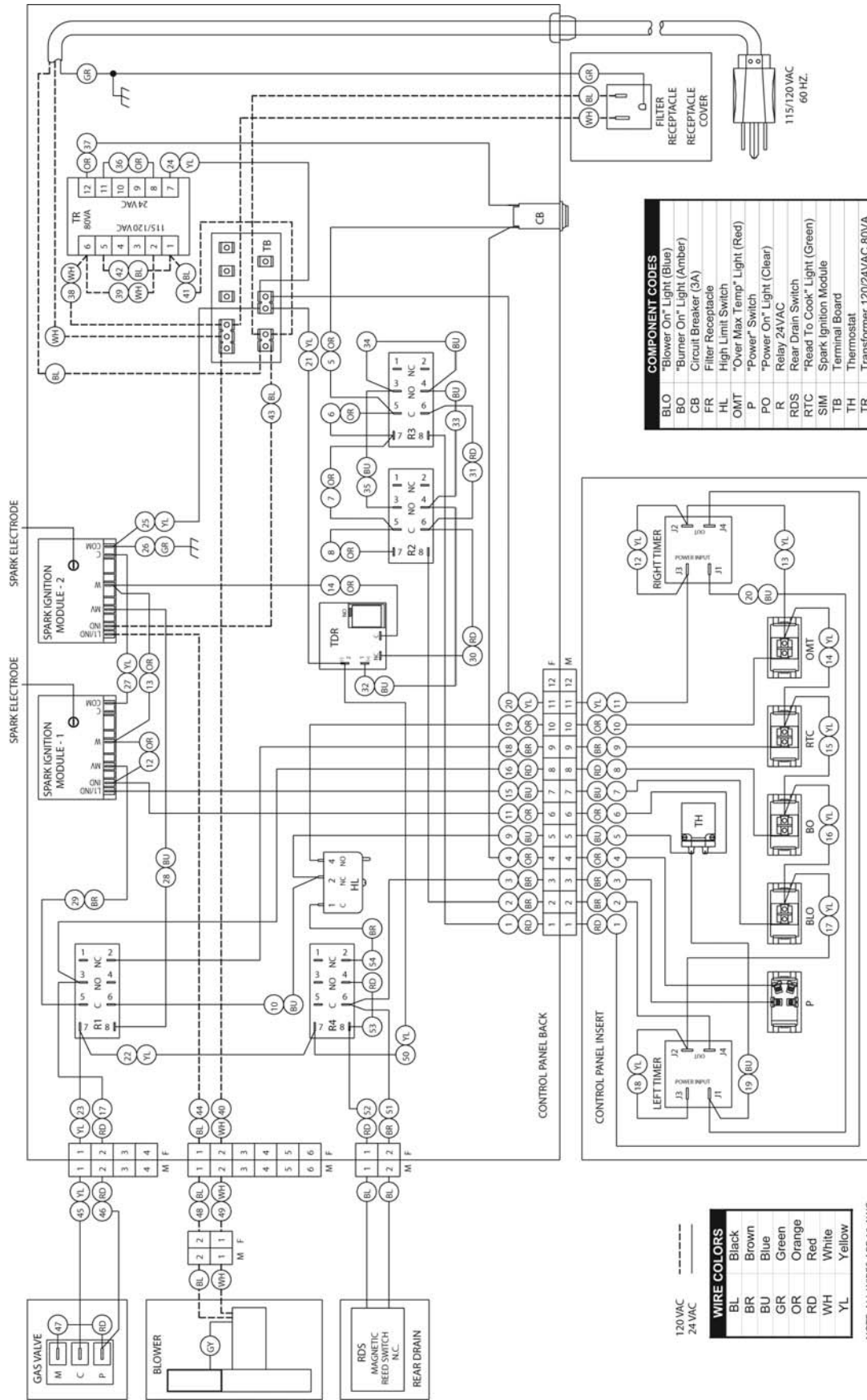

COMPONENT CODES	
BLO	"Blower On" Light (Blue)
BO	"Burner On" Light (Amber)
CB	Circuit Breaker (3A)
FR	Filter Receptacle
HL	High Limit Switch
OMT	"Over Max Temp" Light (Red)
P	"Power" Switch
PO	"Power On" Light (Clear)
R	Relay 24VAC
RDS	Rear Drain Switch
RTC	"Read To Cook" Light (Green)
SIM	Spark Ignition Module
TB	Terminal Board
TH	Thermostat
TR	Transformer 120/24VAC 80VA

WIRE COLORS	
BL	Black
BR	Brown
BU	Blue
GR	Green
OR	Orange
RD	Red
WH	White
YL	Yellow

NOTE: ALL WIRES ARE 18 AWG.

BOB EVANS IFM - 120V CONNECTION DIAGRAM - NO TIMERS, REAR DRAIN - MODEL 2006 WITH TOGGLE SWITCHES

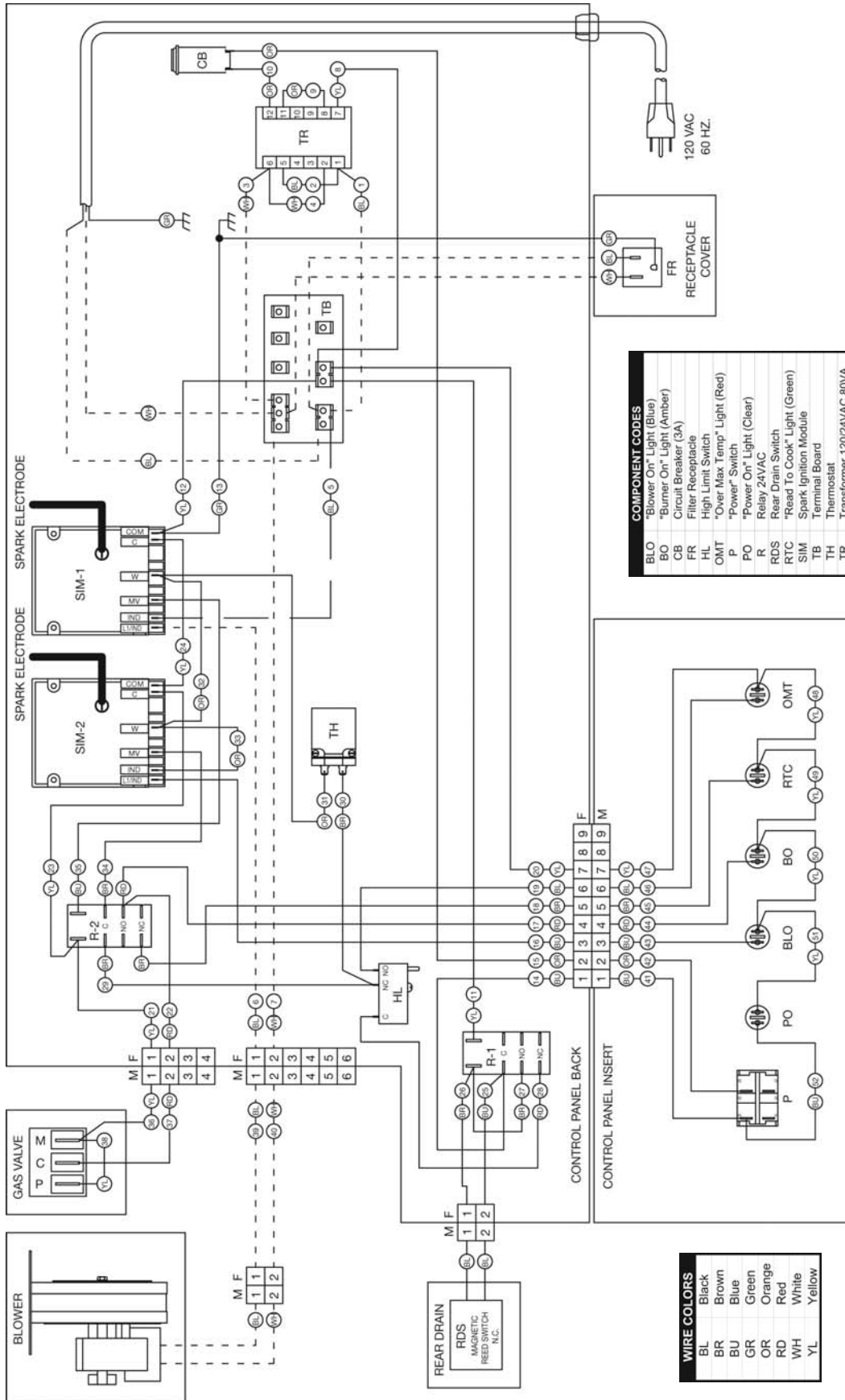

Effective 5/2006

IFM 120V CONNECTION DIAGRAM - TIMERS, FRONT DRAIN - MODEL 2006 WITH TOGGLE SWITCHES

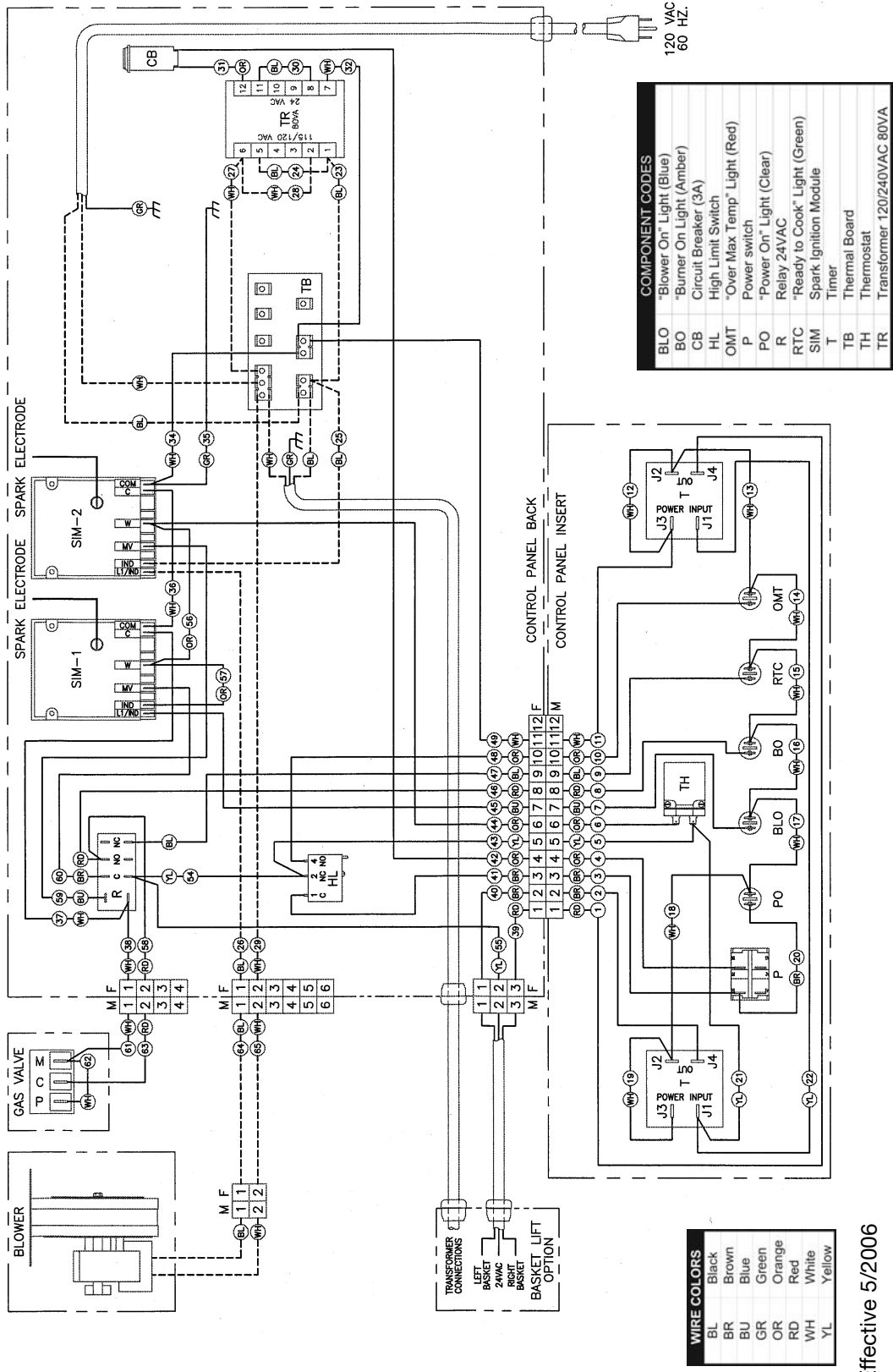

WIRE COLORS	
BL	Black
BR	Brown
BU	Blue
GR	Green
OR	Orange
RD	Red
WH	White
YL	Yellow

COMPONENT CODES	
BLO	Blower On Light (Blue)
BO	Burner On Light (Amber)
CB	Circuit Breaker (3A)
HL	High Limit Switch
OMT	Over Max Temp Light (Red)
P	Power switch
PO	Power On Light (Clear)
R	Relay 24VAC
RTC	Ready to Cook Light (Green)
SIM	Spark Ignition Module
T	Timer
TB	Thermal Board
TH	Thermostat
TR	Transformer 120/240VAC 80VA

Effective 5/2006



WARRANTY

LIMITED WARRANTY

Keating Of Chicago, Inc. ("Keating") warrants to the original purchaser ("Customer"), all new Keating Fryers, Filter Systems, Griddles, Keep Krisp™ Custom Pasta Systems, Top-Side™ Cookers, Computer Timers, Fryer & Pasta Vessels, and Keating replacement parts ("products") installed after June 1, 1994 to be free to defects in material or workmanship, subject to the following terms and conditions.

All products other than Fryer & Pasta Vessels and replacement parts shall be warranted for a period of one year from the date of original equipment installation. Keating replacement parts are warranted for a period of ninety days from the date of installation. Fryer & Pasta Vessels are warranted as described below.

FRYER & PASTA VESSEL WARRANTY

Fryers purchased after June 1, 1994 carry a prorated vessel warranty on defects in materials or workmanship to the Customer based on the following scale:

Time from Installation Date	Fryer Vessel Warranty Credit
13-60 months	100%
61-72 months	80%
73-84 months	60%
85-96 months	40%
97-108 months	20%
109-120 months	10%

The credit for the defective fryer & pasta vessel shall be applied against the cost of the replacement vessel, utilizing Keating's then current price, upon return of the vessel to Keating, (freight to be paid by Keating within the first 2 months only), only during the first 60 months, subject to the limitations described below.

LIMITATIONS OF LIABILITY

In the event of warranty claim or otherwise, the sole obligation of Keating shall be the repair and/or replacement at the option of Keating of the product or component or part thereof. Such repair or replacement shall be at the expense of Keating except that the Customer shall pay the following expenses: all freight and labor expense for Keating replacement parts; for all other products, mileage exceeding 50 miles or travel more than one hour, labor costs of more than one person, overtime rates, truck charges, difference between ground and other mode of transportation, and holiday charges. Any repair or replacement under this Limited Warranty does not constitute an extension of the original warranty for any period for the product or for any component or part thereof. Parts to be replaced under this Limited Warranty will be repaired at the option of Keating with new or functionally operative parts. Keep Krisps and Computer Timers must be returned to Keating for warranty repair or replacement. Field repairs of those items are not authorized.

THE LIABILITY OF KEATING ON ANY CLAIM OF ANY KIND, INCLUDING CLAIMS BASED ON WARRANTY, EXPRESSED OR IMPLIED, CONTRACT, NEGLIGENCE, STRICT LIABILITY OR ANY OTHER THEORIES SHALL BE SOLELY AND EXCLUSIVELY THE REPAIR OR REPLACEMENT OF THE PRODUCT AS STATED HEREIN, AND SUCH LIABILITY SHALL NOT INCLUDE, AND CUSTOMER SPECIFICALLY RENOUNCES ANY RIGHTS TO RECOVER, SPECIAL, INCIDENTAL, CONSEQUENTIAL OR OTHER INJURIES TO PERSONS OR DAMAGE TO PROPERTY, LOSS OF PROFITS OR ANTICIPATED PROFITS, OR LOSS OF USE OF THE PRODUCT.

If any oral statements have been made regarding the Keating products, such statements do not constitute warranties and are not part of the contract sale. This Limited Warranty constitutes the complete, final and exclusive statement with regard to warranties.

THIS LIMITED WARRANTY IS EXCLUSIVE AND IS IN LIEU OF ALL OTHER WARRANTIES WHETHER WRITTEN, ORAL, STATUTORY OR IMPLIED, INCLUDING BUT NOT LIMITED TO ANY WARRANTY OF MERCHANTABILITY OR FITNESS FOR PARTICULAR PURPOSE OR WARRANTY AGAINST LATENT DEFECTS.

EXCLUSIONS

The warranties provided by Keating of Chicago, Inc. do not apply in the following instances:

1. Defects arising out of or resulting from improper installation or maintenance, abuse, misuse, modification or alteration by unauthorized service personnel, or any other condition not attributable to a defect in material or workmanship. Proper installation and maintenance are the responsibility of the installer and Customer, respectively. Proper installation and maintenance procedures are prescribed by the Keating Service Manual.
2. In the event that the product was damaged after leaving the factory due to flood, fire, other acts of God or accident, damage during shipment should be reported to the carrier and is not the responsibility of Keating.
3. In the event the serial number or rating plate has been removed from the product or altered.
4. On parts which would normally be worn or replaced under normal conditions, including but not limited to electric bulbs, fuses, interior and exterior finishes, gaskets and radiants.
5. With regard to adjustments and calibrations such as leveling, tightening of fasteners or plumbing connections, improper gas pressure or improper electrical supply, the checking of and changes in adjustment and calibrations are the responsibility of the installer. Proper installation procedures are prescribed by the Keating Service Manual.
6. In the event of unauthorized repairs or alterations to the Keating product.
7. With the use of sodium chloride in pasta vessels or harsh chemicals in fryer or pasta vessels.

OTHER TERMS AND CONDITIONS

The Customer must provide proof of purchase from Keating.

This Limited Warranty is valid in the 50 United States, its territories, and Canada, and is void elsewhere.

Keating products are sold for commercial use only. If any Keating product is sold as a component of another product or used as a consumer product, such Keating product is sold As Is without any warranty.

If any provision of this Limited Warranty is held to be unenforceable under the law of any jurisdiction, such provision shall be inapplicable in such jurisdiction, and the remainder of the warranty shall remain unaffected. Further in such event, the maximum exclusion or limitation allowable under applicable law shall be deemed substituted for the unenforceable provision.

This Limited Warranty shall be governed by and construed in accordance with the laws of the State of Illinois.

TO SECURE WARRANTY SERVICE

All repair services under this Limited Warranty must be authorized by Keating or performed at Keating. Authorization may be obtained by calling 1-800-KEATING within the Continental United States, Alaska, Hawaii, Puerto Rico and Canada during normal business hours (8 a.m. through 5 p.m. Central Time, Monday through Friday). When calling, please have the following information available: (1) name, address and telephone number of the Customer; (2) location of product, if different; (3) name, model number and serial number of the product; (4) installation date; and (5) description of defect. Keating will then issue a service authorization work order number to one of its approved independent servicing organizations, or request the product or part be shipped to Keating for repair or replacement, as appropriate. Any defective part subject to a claim under this Limited Warranty must be shipped freight prepaid to Keating for testing and examination. Keating's decision as to the cause and nature of any defect under this Limited Warranty shall be final.

KEATING

KEATING OF CHICAGO, INC., 1-800-KEATING, WWW.KEATINGOFCHICAGO.COM

REFILE/warranty 8/07

SERVICE INFORMATION

If you have a service related question call 1-800-KEATING.

Please state the nature of the call; it will ensure speaking with the appropriate person.

Have your serial and model number available when ordering parts.

KEATING OF CHICAGO, INC.

8901 W. 50th Street, McCook, Illinois 60525-6001

Phone: (708) 246-3000 FAX: (708) 246-3100

Toll Free 1-800-KEATING (In U.S. and Canada)

www.keatingofchicago.com

***As continuous product improvement occurs, specifications may be changed without notice.**

KEATING LIMITED WARRANTY CARD

PLEASE COMPLETE AND MAIL AT ONCE--WARRANTY IS NOT IN EFFECT UNTIL CARD IS RETURNED.
WARRANTY CARD IS ALSO AVAILABLE TO COMPLETE ON LINE AT YOUR CONVENIENCE.

COMPANY: _____

ADDRESS: _____

CITY: _____ STATE: _____ ZIP: _____

DEALER: _____

DATE OF PURCHASE: _____ INVOICE NUMBER: _____

SERIAL NUMBER: _____ FRYER FILTER SYSTEM GRIDDLE

REMARKS: _____ TOP-SIDE COOKER HOT PLATE CUSTOM PASTA

I HAVE READ THE INSTALLATION AND OPERATION INSTRUCTIONS.

SIGNED: _____ DATE: _____

"Serving Those Who Serve The Very Best"®