



Nortel Ethernet Routing Switch 8300

Installation — AC Power Supply

Document status: Standard
Document version: 03.01
Document date: 27 August 2007

Copyright © 2007, Nortel Networks
All Rights Reserved.

Sourced in Canada and the United States of America

The information in this document is subject to change without notice. The statements, configurations, technical data, and recommendations in this document are believed to be accurate and reliable, but are presented without express or implied warranty. Users must take full responsibility for their applications of any products specified in this document. The information in this document is proprietary to Nortel Networks Inc.

Restricted rights legend

Use, duplication, or disclosure by the United States Government is subject to restrictions as set forth in subparagraph (c)(1)(ii) of the Rights in Technical Data and Computer Software clause at DFARS 252.227-7013.

Notwithstanding any other license agreement that may pertain to, or accompany the delivery of, this computer software, the rights of the United States Government regarding its use, reproduction, and disclosure are as set forth in the Commercial Computer Software-Restricted Rights clause at FAR 52.227-19.

Statement of conditions

In the interest of improving internal design, operational function, and/or reliability, Nortel Networks Inc. reserves the right to make changes to the products described in this document without notice.

Nortel Networks Inc. does not assume any liability that may occur due to the use or application of the product(s) or circuit layout(s) described herein.

Portions of the code in this software product may be Copyright © 1988, Regents of the University of California. All rights reserved. Redistribution and use in source and binary forms of such portions are permitted, provided that the above copyright notice and this paragraph are duplicated in all such forms and that any documentation, advertising materials, and other materials related to such distribution and use acknowledge that such portions of the software were developed by the University of California, Berkeley. The name of the University may not be used to endorse or promote products derived from such portions of the software without specific prior written permission.

SUCH PORTIONS OF THE SOFTWARE ARE PROVIDED "AS IS" AND WITHOUT ANY EXPRESS OR IMPLIED WARRANTIES, INCLUDING, WITHOUT LIMITATION, THE IMPLIED WARRANTIES OF MERCHANTABILITY AND FITNESS FOR A PARTICULAR PURPOSE.

In addition, the program and information contained herein are licensed only pursuant to a license agreement that contains restrictions on use and disclosure (that may incorporate by reference certain limitations and notices imposed by third parties).

Contents

New in this release	5
Features	5
Other changes	5
<hr/>	
Preface	7
Command line interfaces	7
NNCLI command modes	7
Accessing the NNCLI	9
Returning to the CLI	10
Text conventions	10
Hard-copy technical manuals	11
How to get help	12
<hr/>	
Power supply installation	13
Navigation	13
Power supplies	13
Removing and installing a power filler panel	17
Installing the AC power supply	18
Removing the AC power supply	20
<hr/>	
Electrical specifications for the AC power supply	23

New in this release

See the following sections for details about what's new in *Nortel Ethernet Routing Switch 8300 Installation — MAC Addresses* (NN46200-600) for Release 4.0:

- ["Features"](#) (page 5)
- ["Other changes"](#) (page 5)

Features

There are no new feature-related changes for this document release.

Other changes

This document is reformatted to comply with Nortel Customer Documentation Standards.

Preface

The Nortel Ethernet Routing Switch 8300 is a flexible and multifunctional Layer 2/Layer 3 switch that supports diverse network architectures and protocols. The Ethernet Routing Switch 8300 provides security and control features such as Extensible Authentication Protocol over LAN (EAPoL), Simple Network Management Protocol, Version 3 (SNMP3), and Secure Shell (SSH). The Ethernet Routing Switch 8300 provides quality of service (QoS) for a high number of attached devices and supports future network requirements for QoS for critical applications, such as Voice over IP (VoIP).

This guide is intended for qualified service personnel who need to add or replace an AC power supply in an Ethernet Routing Switch 8300 Series chassis. A qualified service person should have appropriate technical training and experience and be aware of the hazards involved in installing and replacing customer-replaceable units.

This guide provides information about the AC power supply used in the Ethernet Routing Switch 8300 Series chassis and instructions for adding and replacing an AC power supply in the following Ethernet Routing Switch 8300 Series chassis models:

- Ethernet Routing Switch 8306 chassis
- Ethernet Routing Switch 8310 chassis

Command line interfaces

See the following sections for information about the CLI and the NNCLI.

NNCLI command modes

The NNCLI has four major command modes, listed in order of increasing privileges:

- User EXEC
- Privileged EXEC
- Global configuration
- Interface configuration

Each mode provides a specific set of commands. The command set of a higher-privilege mode is a superset of a lower-privilege mode. That is, all lower-privilege mode commands are accessible when using a higher-privilege mode.

The command modes are as follows:

- User EXEC mode
This is the initial mode of access. By default, the User Access Verification Password for this mode is empty, and password checking is disabled. The password can be changed (and password checking enabled) by the system administrator in Global configuration mode. Once the password is changed, it is activated immediately.
- Privileged EXEC mode
This mode is accessed from the User EXEC mode. When accessing this mode, you are prompted to provide a login name and password. The login name and password combination determines your access level in the Privileged EXEC mode and other higher modes.
- Global configuration mode
This mode allows you to make changes to the running configuration. If the configuration is saved, these settings survive reboots of the switch.
- Interface configuration mode
This mode allows you to modify either a logical interface, such as a VLAN, or a physical interface, such as a port/slot.

From either the Global configuration mode or the Interface configuration mode, all the configuration parameters (both global and interface) can be saved to a file. The default name for the configuration parameters file is `config.cfg`. Alternative filenames can also be used.

[Table 1 "NNCLI command modes" \(page 9\)](#) lists the NNCLI command modes, the prompts for each mode, the abbreviated name for each mode, and how to enter and exit each mode.

Prompts are expressed in this table using the format `ERS-8300:5`; however, prompts returned from your switch typically reflect the specific chassis you use. For example, if you use the 8310 chassis, the prompts use the format `ERS-8310:5`. Prompts can be customized, also, using the NNCLI command `snmp-server name <prompt>`.

Table 1
NNCLI command modes

Command mode	Prompt	Mode name	Command/mode to enter or exit mode
User EXEC	ERS-8300:5>	Exec	Default mode when NNCLI is started logout to exit
Privileged EXEC	ERS-8300:5#	privExec	enable to enter from User EXEC mode disable to exit to User EXEC mode
Global Configuration	ERS-8300:5(config)#	config	configure to enter from Privileged EXEC mode exit to exit to Privileged EXEC mode
Interface Configuration	ERS-8300:5(config-if)#	config-if	interface to enter from Global Configuration mode exit to exit to Global Configuration mode

Accessing the NNCLI

When you first power up the Ethernet Routing Switch 8300, the default interface is the Ethernet Routing Switch 8300 CLI. To switch from the CLI to the NNCLI, you must change the NNCLI boot flag to **true** and save the boot configuration file using the following commands:

```
ERS-8310:5# config boot flags nncli true
ERS-8310:5# save boot
```

You must reboot the switch for this change to take effect. After you reboot the switch, access the NNCLI using Telnet, rlogin, or the local console port. You can log in to the switch using your password and the default privilege password **nortel**.

Use the following commands to:

- log in to the software using the default user name and password
- access Global Configuration mode

```
Login: xxxxxx
Password: xxxxxx
ERS-8310:5> enable
```

```
Password: nortel
ERS-8310:5# configure terminal
ERS-8310:5 (config)#
```

Returning to the CLI

The config.cfg file for the CLI and the config.cfg file for the NNCLI are not compatible. If you decide to change the CLI mode to NNCLI, or the reverse, you must use the config.cfg file for the selected mode.

To switch from the NNCLI to the CLI, enter the following commands:

```
ERS-8310:5 (config)# no boot flags nncli
ERS-8310:5 (config)# exit
ERS-8310:5 (config)# save boot
```

You must reboot the switch for this change to take effect.

Text conventions

This guide uses the following text conventions:

angle brackets (< >)	Indicate that you choose the text to enter based on the description inside the brackets. Do not type the brackets when entering the command. Example: If the command syntax is <code>ping <ip_address></code> , you enter <code>ping 192.32.10.12</code>
bold body text	Indicates objects such as window names, dialog box names, and icons, as well as user interface objects such as buttons, tabs, and menu items.
bold Courier text	Indicates command names, options, and text that you must enter. Example: Use the <code>dinfo</code> command. Example: Enter <code>show ip {alerts routes}</code> .
braces ({})	Indicate required elements in syntax descriptions where there is more than one option. You must choose only one of the options. Do not type the braces when entering the command. Example: If the command syntax is <code>show ip {alerts routes}</code> , you must enter either <code>show ip alerts</code> or <code>show ip routes</code> , but not both.

brackets ([])	<p>Indicate optional elements in syntax descriptions. Do not type the brackets when entering the command.</p> <p>Example: If the command syntax is <code>show ip interfaces [-alerts]</code>, you can enter either <code>show ip interfaces</code> or <code>show ip interfaces -alerts</code>.</p>
ellipsis points (. . .)	<p>Indicate that you repeat the last element of the command as needed.</p> <p>Example: If the command syntax is <code>ethernet/2/1 [<parameter> <value>]...</code>, you enter <code>ethernet/2/1</code> and as many parameter-value pairs as needed.</p>
<i>italic text</i>	<p>Indicates variables in command syntax descriptions. Also indicates new terms and book titles. Where a variable is two or more words, the words are connected by an underscore.</p> <p>Example: If the command syntax is <code>show at <valid_route></code>, <i>valid_route</i> is one variable and you substitute one value for it.</p>
plain Courier text	<p>Indicates command syntax and system output, for example, prompts and system messages.</p> <p>Example: Set Trap Monitor Filters</p>
separator (>)	<p>Shows menu paths.</p> <p>Example: Protocols > IP identifies the IP command on the Protocols menu.</p>
vertical line ()	<p>Separates choices for command keywords and arguments. Enter only one of the choices. Do not type the vertical line when entering the command.</p> <p>Example: If the command syntax is <code>show ip {alerts routes}</code>, you enter either <code>show ip alerts</code> or <code>show ip routes</code>, but not both.</p>

Hard-copy technical manuals

You can download current versions of technical documentation for your Ethernet Routing Switch 8300 from the Nortel customer support web site at www.nortel.com/support.

You can print the technical manuals and release notes free, directly from the Internet. Use Adobe Acrobat Reader to open the manuals and release notes, search for the sections you need, and print them on most standard printers. Go to Adobe Systems at the www.adobe.com URL to download a free copy of the Adobe Acrobat Reader.

How to get help

If you purchased a service contract for your Nortel product from a distributor or authorized reseller, contact the technical support staff for that distributor or reseller for assistance.

If you purchased a Nortel service program, contact Nortel Technical Support. To obtain contact information online, go to the www.nortel.com/contactus web page and click Technical Support.

Information about the Nortel Technical Solutions Centers is available from the www.nortel.com/callus web page.

An Express Routing Code (ERC) is available for many Nortel products and services. When you use an ERC, your call is routed to a technical support person who specializes in supporting that product or service. To locate the ERC for your product or service, go to the www.nortel.com/erc web page.

Power supply installation

This guide contains information about installing power supplies.

Navigation

- ["Power supplies" \(page 13\)](#)
- ["Removing and installing a power filler panel" \(page 17\)](#)
- ["Installing the AC power supply" \(page 18\)](#)
- ["Removing the AC power supply" \(page 20\)](#)

Power supplies

The Ethernet Routing Switch 8306 and 8310 chassis have three bays for power supplies. Use the AC power supply for AC input power. The following figure shows an Ethernet Routing Switch 8301AC power supply. The nominal input voltage range for the 8301AC power supply is 100-120 VAC and 200-240VAC, however, the output power is limited to 1140 W maximum at 100-120 VAC nominal input voltage conditions. To obtain full output power (1770 W), you must connect the 8301AC power supply to a 200-240 VAC nominal input voltage source.

Figure 1
8301AC power supply

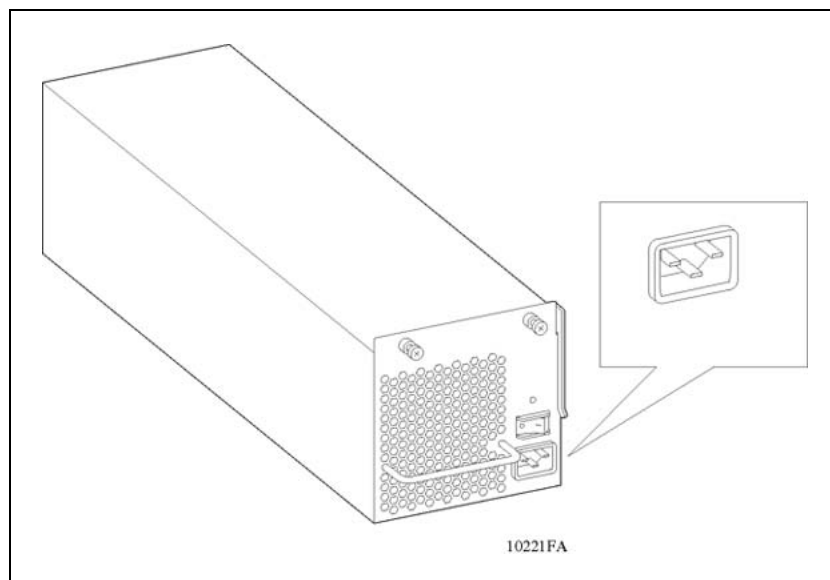
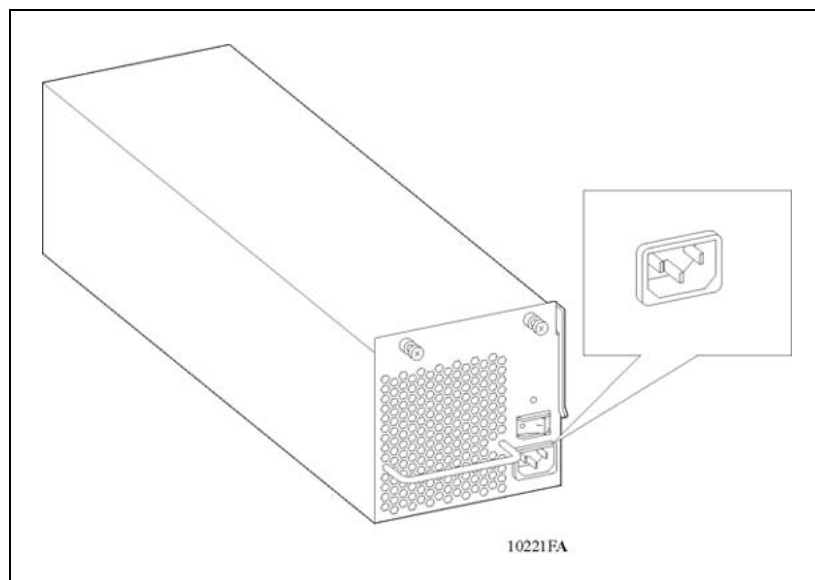

Figure 2 "8302AC power supply" (page 14) shows an Ethernet Routing Switch 8302AC power supply.

The nominal input voltage range for the 8302AC power supply is 100-120 VAC and 200-240VAC, however, the output power is limited to 850 W maximum at 100-120 VAC nominal input voltage conditions. To obtain full output power (1400W), you must connect the 8302AC power supply to a 200-240 VAC nominal input voltage source.

Figure 2
8302AC power supply



The following table describes the power supply LED on the AC power supply.

Table 2
Power supply LEDs

State	Meaning
Off	Power supply not operational. Contact your Nortel Technical Solutions Center.
On (green)	Power supply is ok.

The Ethernet Routing Switch 8300 chassis ships with no installed power supplies. Install the first power supply in the leftmost bay. Power supply bays are logically numbered 1, 2, and 3 left to right as viewed from the front of the chassis for the 8306 and 8310.

Do not install the 8301AC power supply and the 8302AC power supply within the same chassis. This configuration is not supported.

For the 8306 and 8310 chassis, the number of power supplies that you need to install—1, 2, or 3—depends on the following:

- the number of modules installed in the chassis
- PoE requirements
- whether you want an optional redundant power supply or not

[Table 3 "Recommended 8301AC/8302AC power supplies" \(page 15\)](#) lists the number of 8301AC or 8302AC power supplies to install based on the number of installed modules and your power supply redundancy choice.

To provide the required PoE for powered devices (PDs), use [Table 4 "8306/8310 chassis available system power" \(page 16\)](#) to determine the source input power (100-120 VAC or 200-240 VAC) and the number of power supplies. For the input power specifications for each of the modules, see *Nortel Ethernet Routing Switch 8300 Installation — Modules (NN46200-305)*.

Table 3
Recommended 8301AC/8302AC power supplies

Chassis	Number of modules	Number of power supplies	
		Required	Redundant configuration
8306	1-6	1	2
8310	1-6	1	2
	7-10	2	3

Note the following information:

- If a power supply fails when you have a redundant power supply installed, the Ethernet Routing Switch 8300 continues to operate with no interruption of service. The chassis will continue to supply the same module and PoE output power with the remaining power supplies. A trap and syslog message will indicate that the configuration is non-redundant.
- Nortel recommends that you operate the Ethernet Routing Switch 8300 in a redundant configuration at all times to ensure maximum network up time.
- Nortel recommends that you install each power supply on its own dedicated branch circuit. When you plug the power cord for each power supply into a separate AC circuit, the redundant power supply also provides protection against the disconnection or failure of an individual branch circuit or power supply failure.
- If you have installed a redundant power supply, power available for PoE is always determined on an N+1 redundancy. If you have 1 or 2 power supplies in the chassis, you will be allocated PoE power equivalent to one power supply. If you have 3 power supplies in the chassis, you will be allocated PoE power equivalent to 2 power supplies.

Table 4
8306/8310 chassis available system power

Power Supply	Power supply rating	Number of power supplies	Redundancy	Module	PoE	Fans	Total
8301AC	100-120VAC	1	No	600 W	450 W	90 W	1140 W
		2	Yes 1+1	600 W	450 W	90 W	1140 W
		3	Yes 2+1	1290 W	900 W	90 W	2280 W
	200-240VAC	1	No	780 W	900 W	90 W	1770 W
		2	Yes 1+1	780 W	900 W	90 W	1770 W
		3	Yes 2+1	1650 W	1800 W	90 W	3540 W
8302AC	100-120VAC	1	No	535 W	225 W	90 W	850 W
		2	Yes 1+1	535 W	225 W	90 W	850 W
		3	Yes 2+1	1160 W	450 W	90 W	1700 W
	200-240VAC	1	No	860 W	450 W	90 W	1400 W
		2	Yes 1+1	860 W	450 W	90 W	1400 W
		3	Yes 2+1	1810 W	900 W	90 W	2800 W

Removing and installing a power filler panel

A power filler panel maintains the proper cooling airflow in the Ethernet Routing Switch 8300 Series chassis. If you remove a power supply from the Ethernet Routing Switch 8300 Series chassis without replacing it, you must install a power filler panel. When you install a power supply, you must first remove the power filler panel from the power bay.

To remove a filler panel:

Step	Action
------	--------

- 1 Using a Phillips screwdriver, loosen the two captive screws that fasten the power filler panel to the chassis until the screws are free of the threads in the chassis frame.

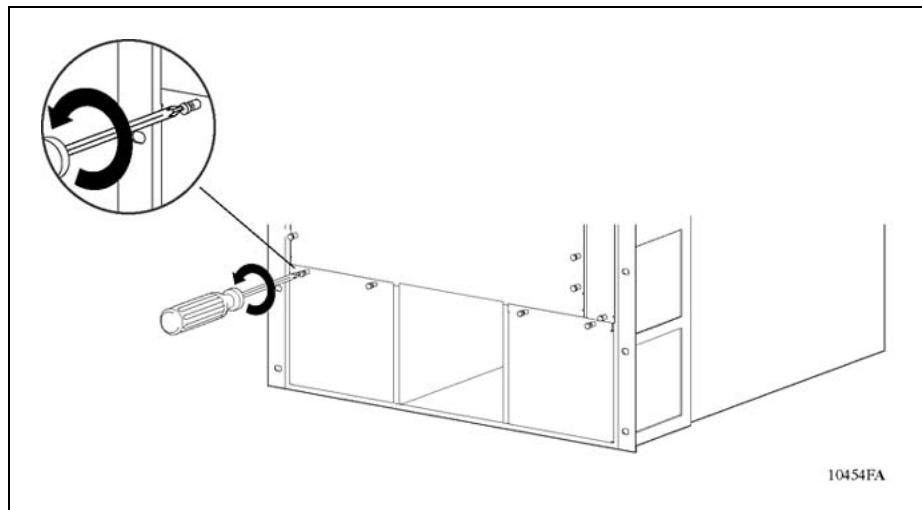

- 2 Pull the power filler panel out of the Ethernet Routing Switch 8300 Series chassis.
Save the power filler panel in case you need to operate the Ethernet Routing Switch 8300 Series chassis with a power supply removed.

—End—

To install a power filler panel:

Step	Action
------	--------

- 1 Place the power filler panel in the empty power supply bay.
- 2 Tighten the two captive screws until the power filler panel is seated firmly.

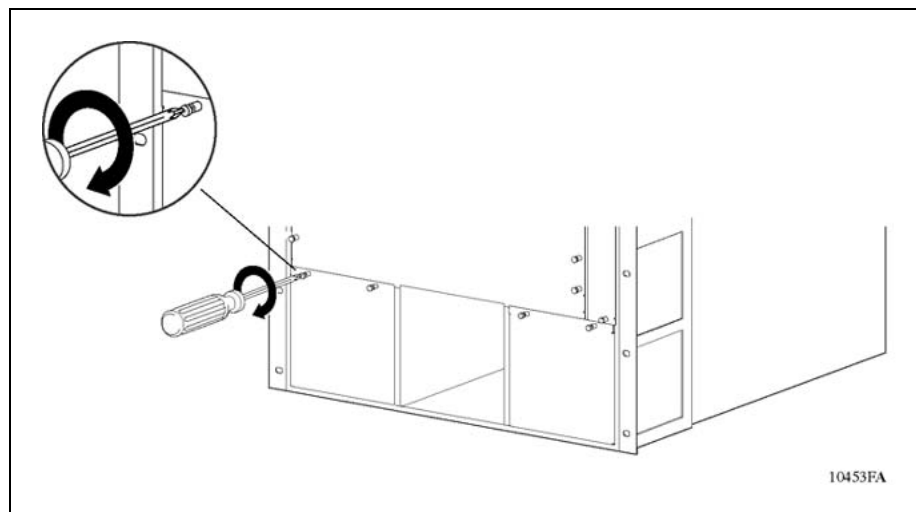

—End—

Installing the AC power supply

Install the AC power supply to provide AC power for components.

Do not install the 8301AC power supply and the 8302AC power supply within the same chassis. This configuration is not supported.

When you first install a 8000 Series chassis that requires two power supplies, you must turn on both power supply units within 2 seconds of each other. If you wait longer to turn on the second power supply, both power supplies shut down. To correct this condition, turn off both power supplies, wait at least 30 seconds, and then turn on both power supplies again within 2 seconds.



DANGER

Due to high-energy hazards of working with components of greater than 240 VA, only qualified service personnel are permitted to install and replace Ethernet Routing Switch 8300 components.

To install an AC power supply:

Step	Action
------	--------

- | | |
|---|---|
| 1 | Remove the filler panel from the power bay if necessary.
For instructions, see "Removing and installing a power filler panel" (page 17). |
|---|---|

**CAUTION**

Save the power filler panel in case you need to operate the 8300 Series chassis with a power supply removed.

- 2 If you are replacing a failed power supply, then remove the failed supply.

For instructions, see "[Removing the AC power supply](#)" (page 20).

- 3 Grasp the handle of the new power supply.

- 4 Push the power supply firmly into the bay.

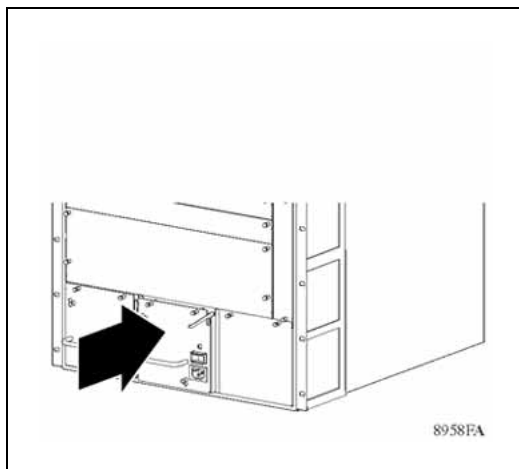

- 5 Tighten the retaining screws until the power supply is seated firmly.

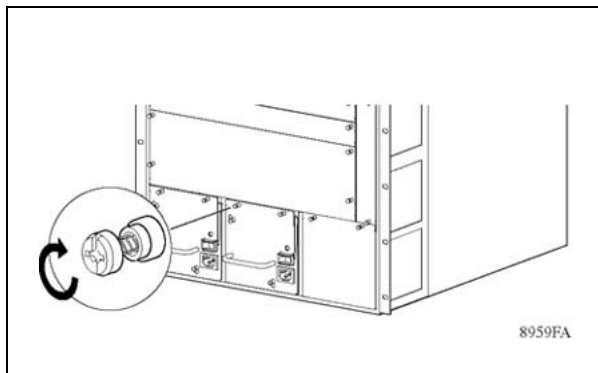

- 6 Connect the power cord to the power supply and to an AC power outlet that is on a circuit with no other equipment connected to it.
Connect each power supply in the chassis to a separate AC circuit.

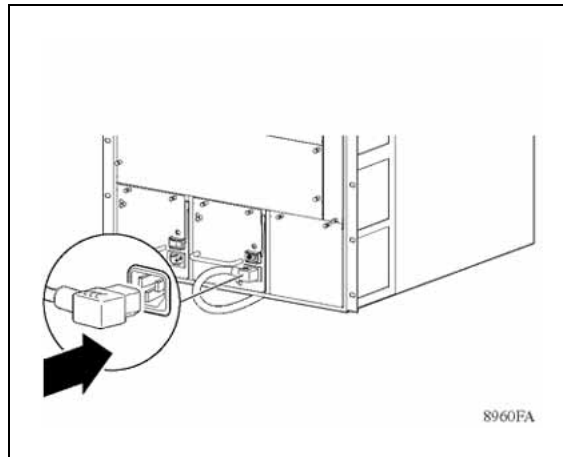

- 7 Turn on the power switch.
The power supply LED on the power supply should light green.

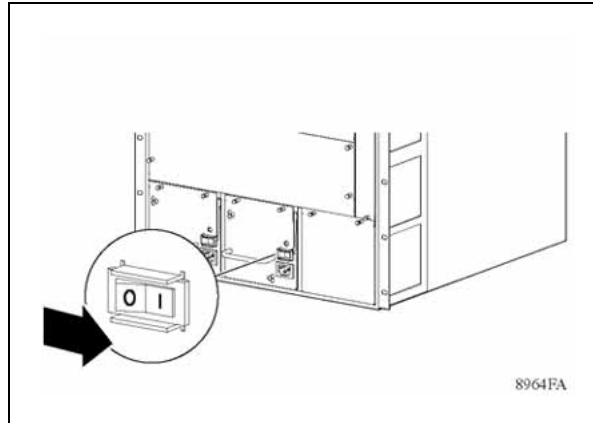

—End—

Removing the AC power supply



DANGER

Due to high-energy hazards of working with components of greater than 240 VA, only qualified service personnel are permitted to install and replace Ethernet Routing Switch 8300 components.

You can remove a redundant power supply without affecting the operation of the Ethernet Routing Switch 8300 Series switch. When you remove a power supply, the LED on the power supply turns off, and the Ethernet Routing Switch 8300 Series Chassis automatically redistributes the load to the remaining power supplies.

You should replace a failed power supply as soon as possible to restore high-availability operation.

**CAUTION**

To maintain proper cooling, never operate the Ethernet Routing Switch 8300 Series chassis with an empty power supply bay. If you are replacing a failed power supply and you do not have a power filler panel, leave the failed power supply installed until a replacement power supply is available.

To remove an AC power supply:

Step Action

- 1 Turn off the power switch on the power supply that you are replacing.

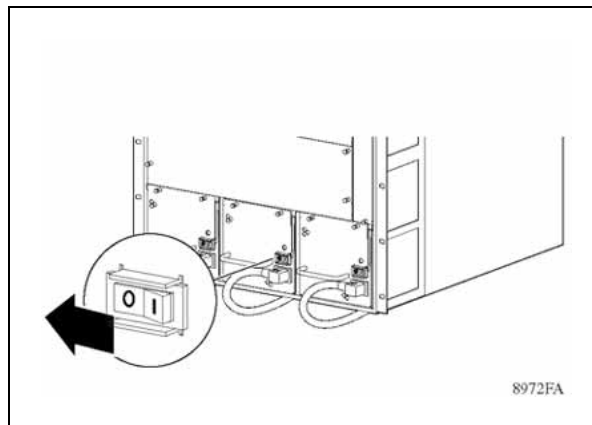

- 2 Disconnect the power cord from the power outlet and from the power supply.

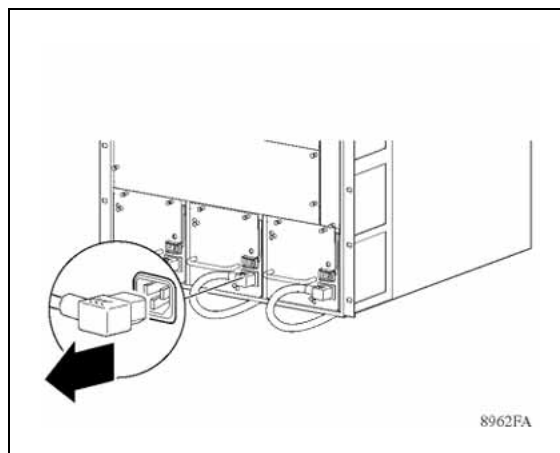

- 3 Loosen the two retaining screws on the power supply.

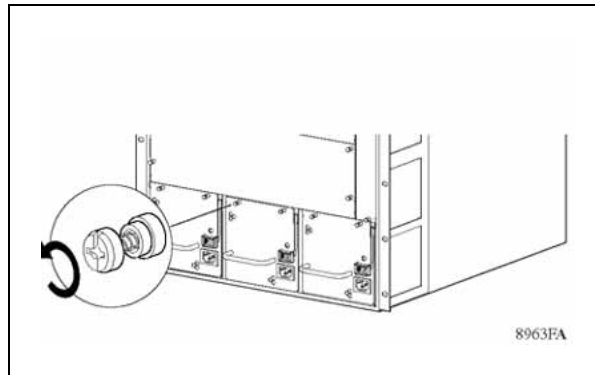

- 4 Lift the extractor lever to disconnect the power supply from the backplane connector.

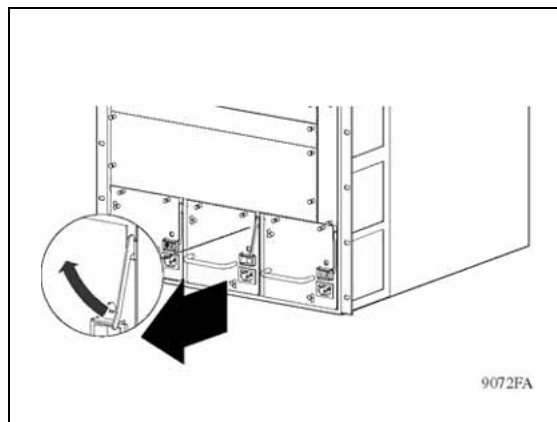

- 5 Pull the power supply out of the chassis.
- 6 Install a new power supply (see ["Installing the AC power supply" \(page 18\)](#)) or install a power filler panel (see ["Removing and installing a power filler panel" \(page 17\)](#)).

—End—

Appendix

Electrical specifications for the AC power supply

This appendix lists the electrical specifications for the Ethernet Routing Switch 8301AC power supply. Refer to your chassis installation manual for system power specifications.

The following table list the power specifications for the Ethernet Routing Switch 8301AC power supply.

Table 5
Ethernet Routing Switch 8301AC power specifications

AC Input Power Ratings		
Input voltage range (nominal):	100-120 VAC	200-240 VAC
Input current (nominal):	16 A	12 A
Frequency range (nominal):	50-60 Hz	50-60 Hz
Input VA	1600 VA	2234 VA
Input power consumption:	1584 W	2212 W
Heat dissipation (thermal/output):	1515 BTU/hr	1508 BTU/hr
Hold-up time:	20 ms	20 ms
DC Output Power Ratings		
Max. output power (combined):	1140W (1050W + 90W fans)	1770 W (1680W + 90W fans)
Non-PoE:	3.3 VDC @ 150 A 12 VDC @ 65 A	3.3 VDC @ 150 A 12 VDC @ 65 A
PoE:	50 VDC @ 18 A	50 VDC @ 18 A
Fans:	12 VDC @ 7.5 A	12 VDC @ 7.5 A

Note the following information:

- The maximum steady-state output power is limited to a total of 1140 W for any combination of output voltages/currents at low-line 100-120 VAC nominal input voltage conditions.
- The maximum steady-state output power is limited to a total of 690 W for any combination of output voltages/currents, excluding the 50 VDC source at low-line 100-120VAC nominal input voltage conditions. This limitation is required to ensure that there is sufficient PoE power or 450 W total at this input voltage condition.
- The maximum steady-state output power is limited to a total of 870W for any combination of output voltages/currents, excluding the 50 VDC source at high-line 200-240VAC nominal input voltage conditions. This limitation is required to ensure maximum PoE power or 900 W total for the 50 VDC source at this input voltage condition.
- To obtain the full output power rating of 1770 W, you must connect the power supply to a nominal (200-240VAC) input voltage source.

The following table list the power specifications for the Ethernet Routing Switch 8302AC power supply.

Table 6
Ethernet Routing Switch 8302AC power specifications

AC Input Power Ratings		
Input voltage range (nominal):	100-120 VAC	200-240 VAC
Input current (nominal):	12 A	9 A
Frequency range (nominal):	50-60 Hz	50-60 Hz
Input VA	1192 VA	1768 VA
Input power consumption:	1180 W	1750 W
Heat dissipation (thermal/output):	1126BTU/hr	1195 BTU/hr
Hold-up time:	20 ms	20 ms
DC Output Power Ratings		
Max. output power (combined):	850W (760W + 90W fans)	1400 W (1310W + 90W fans)
Non-PoE:	3.3 VDC @ 150 A 12 VDC @ 65 A	3.3 VDC @ 150 A 12 VDC @ 65 A
PoE:	50 VDC @ 18 A	50 VDC @ 18 A
Fans:	12 VDC @ 7.5 A	12 VDC @ 7.5 A

Note the following information:

- The maximum steady-state output power is limited to a total of 850 W for any combination of output voltages/currents at low-line 100-120 VAC nominal input voltage conditions.
- The maximum steady-state output power is limited to a total of 625 W for any combination of output voltages/currents, excluding the 50 VDC source at low-line 100-120VAC nominal input voltage conditions. This limitation is required to ensure that there is sufficient PoE power or 225 W total at this input voltage condition.
- The maximum steady-state output power is limited to a total of 950 W for any combination of output voltages/currents, excluding the 50 VDC source at high-line 200-240VAC nominal input voltage conditions. This limitation is required to ensure maximum PoE power or 450 W total for the 50 VDC source at this input voltage condition.
- To obtain the full output rating of 1400 W, you must connect the power supply to a nominal (200-240 VAC) input power voltage source.

Nortel Ethernet Routing Switch 8300

Installation — AC Power Supply

Copyright © 2007, Nortel Networks
All Rights Reserved.

Publication: NN46200-301
Document status: Standard
Document version: 03.01
Document date: 27 August 2007

Sourced in Canada and the United States of America

To provide feedback or report a problem in this document, go to www.nortel.com/documentfeedback

Nortel, the Nortel logo, and the Globemark are trademarks of Nortel Networks.
Adobe and Acrobat Reader are trademarks of Adobe Systems Incorporated.
Microsoft, Windows, and Windows NT are trademarks of Microsoft Corporation.
All other trademarks are the property of their respective owners.

