

/ Marley NC[®] Class Cooling Tower /



Q u i e t B y D e s i g n



Four-cell NC Class cooling tower serving a municipal power plant.

The Result of Sound Engineering



The NC Class not only sets the benchmark for low sound levels it also sets the benchmark for some of the highest crossflow tonnage densities per box in the industry. For over 50 years NC cooling towers have delivered thermal performance, low maintenance, versatility of options and outstanding value. But, of even greater significance, the NC Class is now quieter.

The redevelopment, redesign, the “evolution” of the NC cooling tower into the NC Class was the first project at SPX Cooling Technologies to fully utilize and employ our new ISO 9001 Certified “Product Development Process.”

■ Long Life Construction

Available in series 300 stainless steel or rugged heavy mill galvanized steel. Marley ISO certified plants assure quality factory-assembly. Plus, the NC Class stainless steel tower comes with SPX Cooling Technologies' exclusive 5-year limited warranty.

■ Low Operating Costs

Marley's high-efficiency fill and fans, gravity-flow water distribution, and efficient mechanical drive systems work together to offer maximum cooling with minimum power use.

■ All Season Performance

Performs as specified in the heat of summer—responds well to energy-management techniques in the spring and fall—operates virtually ice-free in the dead of winter—and offers simple maintenance all year long.

■ Real World Design

Designed for severe wind, seismic, shipping, operating and live loads.

■ CTI Certified

Plus, we guarantee the thermal performance of each tower as installed.

■ Factory Mutual Approved

FM approval is available on the entire line of NC Class cooling towers. Currently 94 NC Class tower models are FM approved without any additional cost.



Proven Design Guaranteed Performance

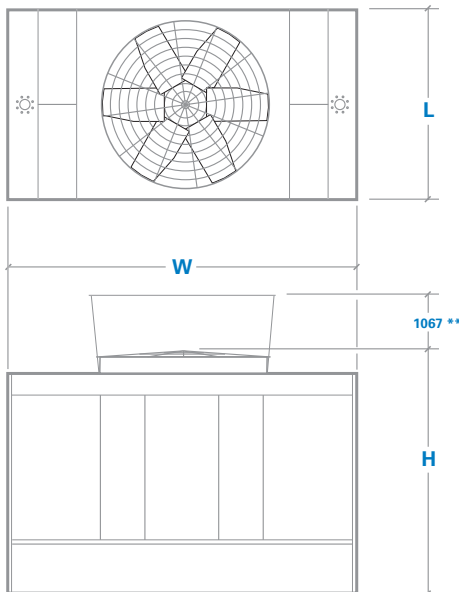

TOWER MODELS	TONS	L	W	H
NC8301	94-180	1956	4267	3099
NC8302	118-242	2413	4725	3099
NC8303	154-297	2413	4725	3632
NC8304	217-372	2718	5182	3962
NC8305	281-520	3327	5715	3962
NC8306	350-582	3632	6045	3962
NC8307	343-651	3632	6833	4064
NC8309	481-750	4242	6833	4064**
NC8310*	567-915	3327	6833	6045**
NC8311*	503-1000	3632	6833	6045**
NC8312*	626-1274	4242	6833	6045**

*Two-story modular cells

**Some models in this box size require a taller fan cylinder

NC[®]class

In a Class by Itself

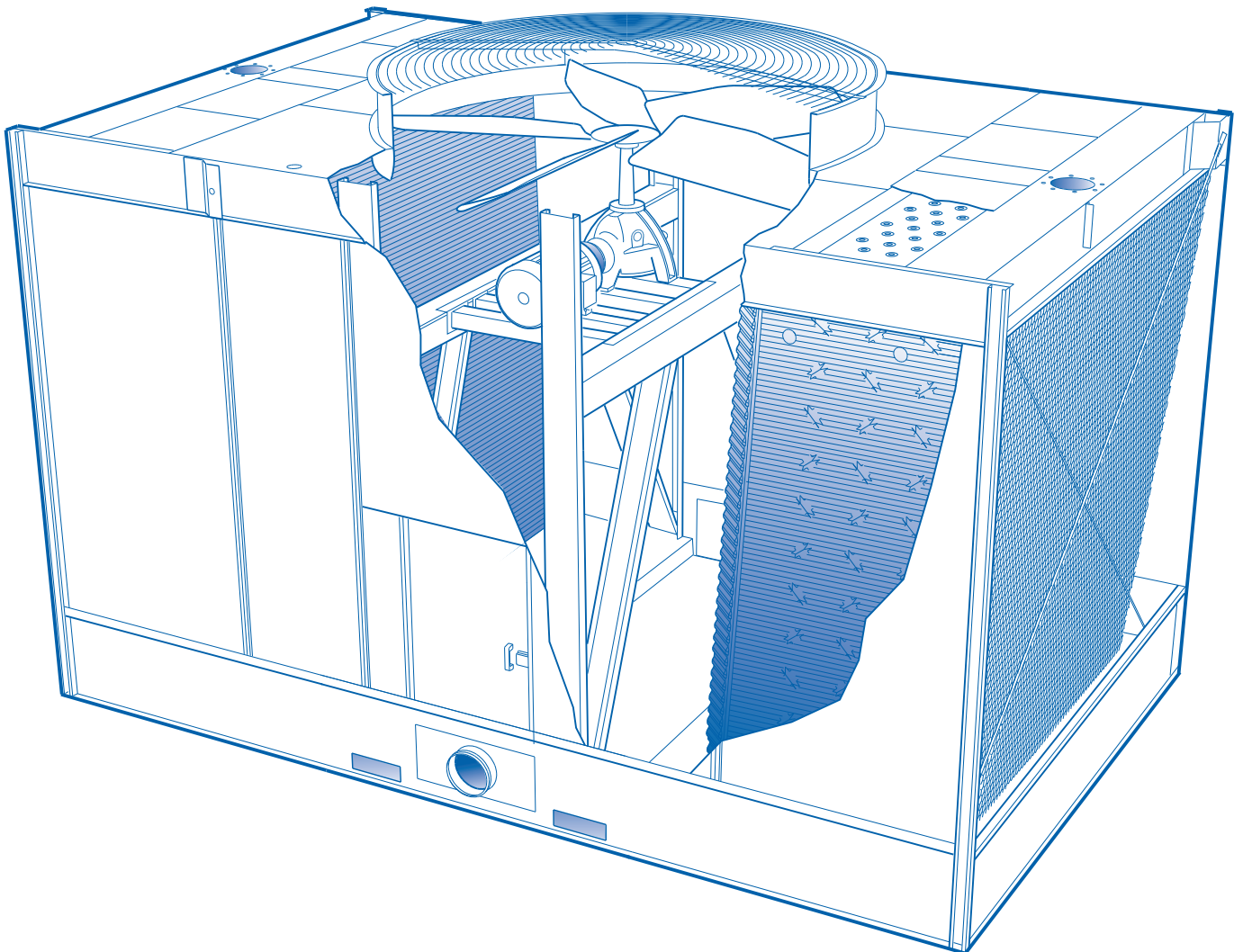

NC Feature Highlights

■ Air Movement Package

- Removable fan guard—welded heavy gauge rods. Hot dip galvanized after fabrication.
- Eased inlet fan cylinder—ensures full area, low turbulent airflow through the cylinder.
- High efficiency fan—wide-chord design for maximum efficiency at low fan tip speeds.
- Marley System 5 Geareducer® drive—requires no oil changes for five full years. Offers significant savings in maintenance costs. Marley SofTork™ coupling absorbs excessive shock loads at start-up.
- Marley PowerBelt™ drive (limited current availability)—all aluminum sheaves, easy belt replacement and 40,000-hour bearing life.
- TEFC Fan Motor—1.15 service factor, variable torque, and specially insulated for cooling tower duty.
- The NC Class air movement package including the structural support—guaranteed against failure for a period of five full years. The motor is warranted separately by the motor manufacturer.

■ Water Distribution System

- Multiple choices of piping connection options—single inlet, dual inlet, top, side or bottom inlet, side outlet or bottom outlet—designed to have the right connections for your application.
- Gravity flow distribution system—allows easy, nonrestrictive maintenance. Basin covers are standard.
- Marley Spiral Target polypropylene nozzles—delivers precise distribution of water over the fill area.
- Marley MX thermoformed PVC film fill—suspended from structural steel tubing. Integral louvers keep circulating water confined to fill, even at low air rates.
- Drift Eliminators—limit drift losses to no more than .005% of the design L/s flow rate.

■ Structure

- Crossflow configuration—provides easier and safer maintenance.
- Series 300 stainless steel or G600 galvanized steel construction.
- Factory assembled—ensures final field installation will be hassle-free.
- Two large access doors—provides nonconfining, quick visual inspection of cold water basin, internal structure, drift eliminators and mechanical equipment in the plenum area.

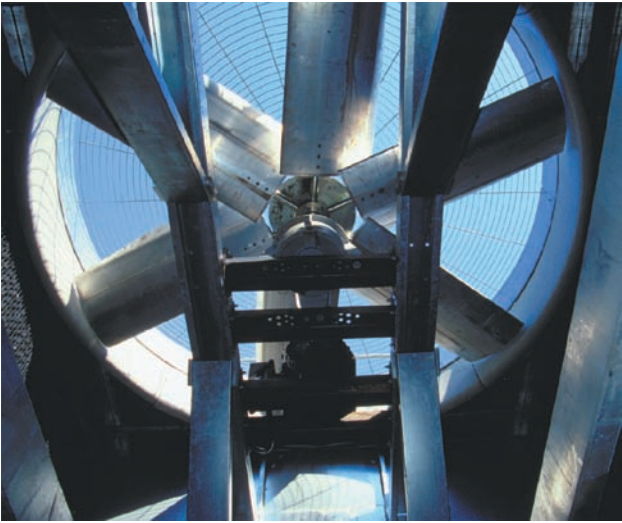

All NC Class cooling towers are designed for low sound levels using high blade-count, wide-chord fans for maximum efficiency at low tip speeds. For those extreme, low sound applications, consider the NC Class low sound “L” models. To achieve the very lowest possible sound levels while maintaining efficiency, “L” models are carefully selected with the best available combination of motor, drive ratio, fan blade-count and blade profile.

Mechanically Correct Quiet by Design

■ High Efficiency Axial Fan

Adjustable-pitch fan blades permit maximum utilization of rated horsepower—allows field adjustments to optimize tower performance.

■ System 5 Geareducer

The Geareducer option requires no oil changes for five full years—the lowest maintenance requirements in the industry. Reduced waste stream and environmental impact.

Independent testing has proven a Marley Geareducer is up to 4 dBA quieter than the gearboxes used by most other cooling tower manufacturers.

■ Fan Motor

TEFC 1.15 service factor, horizontal-shaft motor designed to Marley specifications for cooling tower duty. Specially insulated for humid cooling tower service.

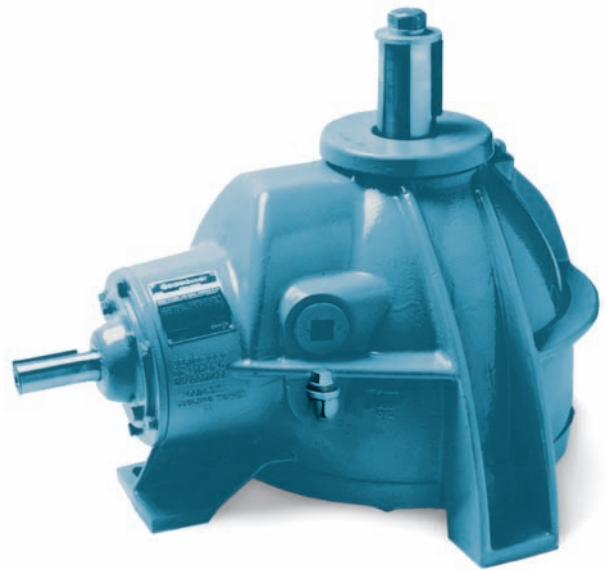

Marley 2400 Geareducer

■ SofTork Coupling

Absorbs excessive shock loads at start-up—forgives minor misalignment between the motor and Geareducer.

■ Five-Year Mechanical Warranty

Five-year total mechanical equipment warranty including mechanical equipment support, plus our exclusive 5-year maintenance-free System 5 Geareducer.

Popular Options

- **Single Inlet Connection**—choose from either side inlet or bottom inlet connections. All piping from the inlet connection to the distribution basins is part of the tower package*.
- **Handrail and Ladder**—provides sturdy and stable access to the top of your tower. Ladder safety cages and ladder extensions are also available.
- **Access Door Platform**—steel structure and bar-grating attached to and supported by the tower. Full length bar grating interior walkways are also available.
- **Mechanical Access Platform**—provides internal ladder to elevated bar-grating platform with handrail, facilitates maintenance access. Exterior platform with ladder and handrail also available for outside motor option. *Modular tower only.*
- **Motor Location Outside**—easily accessible and is not subjected to the constant humidity that exists inside the tower plenum. This option uses a Marley full-floating stainless steel driveshaft.
- **Distribution Basin Dam**—allows significant variations in flow rates while protecting the tower from the disadvantages of poor water distribution—icing, fill scaling and erratic performance. Permits the operator to stage chillers and pumps, and still circulate water efficiently over all cooling tower cells with the benefit of dramatically reduced fan hp for a given heat load.
- **Control Systems**—ranges in sophistication from standard fan starters and disconnects to Programmable Logic Controllers that work in conjunction with your building or process system.
- **Variable Speed Drive**—provides the ultimate in temperature control, energy management, sound control and mechanical equipment longevity.
- **Solid State Water Level Control Package**—monitor basin water level with solenoid-valve water makeup. Configurations include makeup along with high and low water level alarm and cutoff and electric basin heater cutoff.
- **Stainless Steel Welded Collection Basin**—all collection basin parts exposed to the circulating water including structural members projecting into the basin, plus attaching hardware, and all basin options, including sumps are heavy-gauge series 300 stainless steel. *Galvanized steel tower option.*
- **Stainless Steel Distribution Basins**—corrosion is usually most aggressive in the hot water distribution basins. Stainless steel provides long, trouble-free service life. *Galvanized steel tower option.*
- **Extended Geareducer Oil Line**—includes a dipstick to check Geareducer oil level. Located at the fan deck level near the side of the tower.
- **Air Inlet Screens**—keep leaves and debris out of the tower with factory-installed, U-edged, galvanized wire mesh screens over the air inlets.

* Standard pipe material is schedule 40 PVC. Steel piping is available as an option and/or where FM approval is required.

One of the larger multicell NC Class models with a variety of options including: motor outside, handrail, ladder, ladder safety cage.



Technical Reference Manual TECH NC provides engineering schematics, data, and information necessary for initial tower layout. See your Marley sales representative for a copy or download at spxcooling.com.

Product Specifications SPEC SSNC and SPEC NC detail the tower in the form of specification language, and provide technical as well as common-sense information on the importance of your specifications. SPEC SSNC applies to the stainless steel NC Class models and SPEC NC applies to the galvanized NC Class models. See your Marley sales representative for a copy of each or download at spxcooling.com.



The Marley Difference

Just about anyone can put together a device that cools water. Some might even claim to be leaders in the cooling tower business. But the fact is, one company has had more new ideas than all the rest combined. No other cooling tower manufacturer has advanced the industry more than the combined resources of SPX Cooling Technologies.

If we can help in any way, feel free to call us. To find your Marley representative, call +44 (0) 1905 720 200 or check the web at spxcooling.com.

SPX Cooling Technologies

Balcke | Hamon Dry Cooling | Marley

Gregory's Bank
Worcester WR3 8AB, UK
+44 (0) 1905 720 200
info.uk@ct.spx.com
www.spxcooling.com

In the interest of technological progress, all products are subject to design and/or material change without notice.
©2007 SPX Cooling Technologies
uk_NC-07