

# Masterbuilt Electric Turkey Fryer WARRANTY INFORMATION

To validate your warranty, please fill out and return  
this portion within 30 days of the date of purchase.

1. Name \_\_\_\_\_
2. Address \_\_\_\_\_  
City \_\_\_\_\_  
State \_\_\_\_\_ Zip \_\_\_\_\_  
Phone Number \_\_\_\_\_ e-mail \_\_\_\_\_
3. Dealer's Name \_\_\_\_\_
4. Dealer's Location \_\_\_\_\_
5. Date of Purchase \_\_\_\_\_
6. What brands of outdoor cookers have you previously owned? (Optional)  
\_\_\_\_\_
7. Serial # \_\_\_\_\_ and/or Model # \_\_\_\_\_
8. Manual Code (Located at bottom of page) \_\_\_\_\_

Mail to:  
Masterbuilt  
450 Brown Avenue,  
Columbus, Georgia 31906

Thank you for your purchase and filling out this warranty questionnaire.  
Masterbuilt has made every effort to provide you with a quality,  
long-lasting, trouble-free product.

**In the event of a problem, please call  
our toll free number 1-800-489-1581**

Thank You for purchasing this Masterbuilt product.



450 Brown Avenue  
Columbus, Georgia 31906

www.masterbuilt.com

**Manual Code 092503G**



# ELECTRIC TURKEY FRYER, BOILER & STEAMER



For Cooking  
Made Simple, See  
**STARTER TIPS**  
On Page 1

OPERATION MANUAL &  
SAFETY INSTRUCTIONS  
MODELS ETF, ETFT, SETFT, SETFTTS



HOUSEHOLD  
USE ONLY

CSA CERTIFIED TO  
UL STANDARD 1083

Important Safeguards .....	<b>1</b>
Parts Description .....	<b>2</b>
Getting Ready .....	<b>3</b>
Using The Appliance .....	<b>4</b>
Reset Function .....	<b>5</b>
Serving .....	<b>5</b>
Storage & Maintenance .....	<b>6</b>
Recipes .....	<b>7</b>
Cooking Times .....	<b>8</b>
Warranty Information .....	<b>9</b>
Warranty Card .....	<b>BACK</b>
Contact Information .....	<b>BACK</b>

## STARTER TIPS

**FOR BEST RESULTS READ** the following start up tips before using your electric turkey fryer, seafood kettle and boiler. Please remember this is an ELECTRIC turkey fryer, and has different characteristics than a gas fryer

**PRE-HEATING** oil or water may take up to 55 minutes. Take advantage of this time to prepare your turkey or other foods for cooking. For optimum performance, completely pre-heat unit to cooking temperature before frying or boiling foods. Keeping THE LID ON during pre-heating and cooking cycles will reduce pre-heating time, and keep temperature more consistent.

**INDICATOR LIGHT** (See Page 4) will turn OFF once the designated temperature has been reached. The indicator light will turn ON when the food is placed into the hot liquid, indicating the element is heating and may not turn OFF during the cooking process, especially when frying a turkey.

**14 POUNDS** is the **LARGEST** recommended turkey to cook. Any turkey over 14 pounds may not cook completely, especially in center of breast and drumsticks. When cooking more than one turkey, or more than one basket of food, allow enough time for the oil or water to re-heat to designated temperature before adding additional food.

**FOR SAFETY**, the heating element will only heat up when properly mounted to the mounting bracket (See Page 3). This is a powerful heating element and may cause occasional circuit breaker tripping. Try to minimize occurrences by operating any additional appliances on a separate circuit. This may take a little trial and error, but **WILL NOT DAMAGE** your fryer or your home's electrical system.

Masterbuilt Manufacturing, Inc. warrants the plug, cord, control panel, heating element, inner pot, outer shield, basket, hook and lid to be free from defects in material and workmanship for one year. Masterbuilt's warranty does not cover rust of the unit. Within this period, Masterbuilt shall correct any defect by repairing or replacing defective parts of the equipment or making available the parts from, Columbus, Georgia, F.O.B.

Masterbuilt Manufacturing, Inc. requires reasonable proof of purchase and suggests that you keep your receipt. Failure to complete and return warranty information (on back page) will make product warranty null and void. Upon the expiration of such warranty, all such liability shall terminate.

This warranty does not include the cost of property damage due to the failure of the product and does not cover damage due to the misuse, abuse, accident, damage arising out of transportation, or damage incurred through commercial use of this product. THIS EXPRESS WARRANTY IS THE SOLE WARRANTY GIVEN BY THE MANUFACTURER AND IS IN LIEU OF ALL OTHER WARRANTIES, EXPRESSED OR IMPLIED, INCLUDING IMPLIED WARRANTY OR MERCHANTABILITY OR FITNESS FOR A PARTICULAR PURPOSE. Neither Masterbuilt Manufacturing, Inc. , nor the retail establishment selling this product, has authority to make any warranties or to promise remedies in addition to or inconsistent with those stated above. Masterbuilt's maximum liability, in any event, shall not exceed the purchase price of the product paid by the original consumer/purchaser. Some states do not allow the exclusion or limitation of incidental or consequential damages. In such a case, the above limitations or exclusions may not be applicable.

Notwithstanding this limitation of warranty, the following specific restrictions apply for California residents. If service, repair, or replacement of the product is not commercially practicable, the retailer selling the product or Masterbuilt will refund the purchase price paid for the product, less the amount directly attributable to use by the original buyer prior to the discovery of the nonconformity. In the state of California only, you may take the product to the retail establishment selling this product, in order to obtain performance under warranty.

This expressed warranty gives you specific legal rights, and you may also have other rights which vary from state to state.

## Cooking Times

**NON FROZEN FOODS - Heating oil to 400°F may take up to 55 min.**

Food	Maximum Quantity	Temperature	Time
French Fries	3 lbs	375°	5 - 7 min
Fried Chicken	10 pieces	350°	14 - 18 min
Mushrooms	2 lbs	300°	10 - 12 min
Fish Fillets	2 lbs	325°	6 - 8 min
Turkey	10 - 14 lbs	400°	See Page 7
Hot Wings	3 lbs	400°	See Packaging

ALL TIMES APPROXIMATE. NEVER LEAVE UNATTENDED.

**FROZEN FOODS - Refer to instructions on food packaging first.**

Food	Maximum Quantity	Temperature	Time
French Fries	3 lbs	400°	5 - 7 min
Chicken Nuggets	2 lbs	375°	7 - 8 min
Mushrooms	2 lbs	375°	8 - 9 min
Fish Sticks	2 lbs	375°	6 - 7 min
Corn Dogs	10	375°	See Packaging
Cheese Sticks	2 lbs	305°	See Packaging

ALL TIMES APPROXIMATE. NEVER LEAVE UNATTENDED.

**⚠ WARNING Use extreme caution when cooking frozen foods. Never fill oil past fill line or exceed maximum amount of food in basket. Spill over can cause serious injury. Slowly lower basket into oil and cover with lid. Always wear protective gloves or mitts.**

## ⚠ WARNING – IMPORTANT SAFEGUARDS

**When using electrical appliances, basic safety precautions should always be followed, including the following:**

1. Read all instructions.
2. **Never move appliance when oil or water is above 100°F.**
3. Do not touch hot surfaces. Use handles and knobs.
4. To protect against electric shock, do not immerse cord, plugs, or any part of control panel in water or other liquid.
5. This is an ATTENDED appliance. Do not leave this appliance unattended while heating oil, grease, water or cooking food. Even after use, never allow children or pets near the appliance. Heated oil or water inside the cooking pot remains dangerously hot hours after use.
6. Close supervision is necessary when any appliance is used near children.
7. ALWAYS keep children and pets away from cooker.
8. Unplug from outlet when not in use and before cleaning. Allow to cool before putting on or taking off parts, and before cleaning the appliance.
9. Do not operate appliance with a damaged cord, plug, or after the appliance malfunctions, or has been damaged in any manner. Contact Masterbuilt's customer service, for replacement part information, 1-800-489-1581.
10. The use of accessory attachments, not recommended by Masterbuilt, may cause injuries.
11. Do not use outdoors.
12. Do not let cord hang over edge of table or counter, or touch hot surfaces.
13. Do not place on or near a hot gas, electric burner, or in a heated oven.
14. Always, attach plug to appliance first, then plug cord in the wall outlet. To disconnect, turn all controls to OFF, then remove plug from wall outlet.
15. Do not use appliance for other than intended use.
16. If oil begins to smoke, IMMEDIATELY turn appliance off.
17. NEVER overfill the cooking pot past the fill line. Follow instructions in this manual for establishing proper oil, grease or water levels.
18. Do not move appliance while in use.
19. Do not immerse electric cord or control panel in water.
20. Open lid with caution to prevent burns from escaping steam (see graphic below).
22. **SAVE THESE INSTRUCTIONS.**

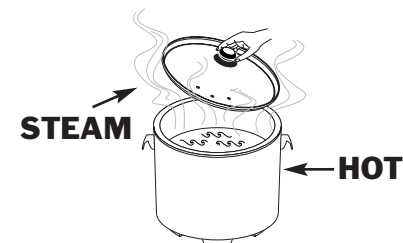

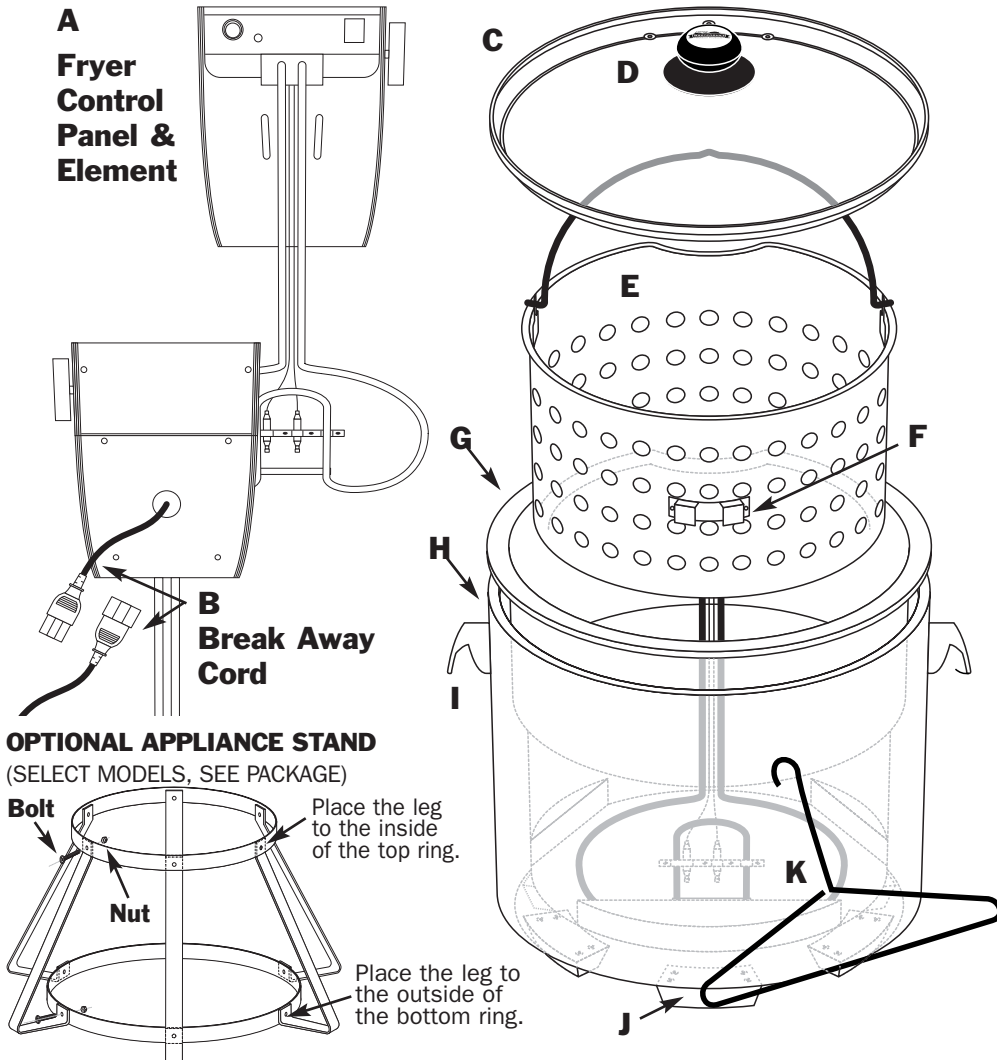

**OPTIONAL APPLIANCE STAND**  
(SELECT MODELS, SEE PACKAGE)

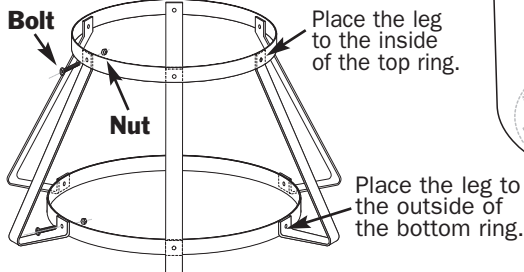

Bolt each leg to the stand as shown.

### ASSEMBLY INSTRUCTIONS

Place Inner Pot (G) into Outer Pot (H). Align notched openings on Inner Pot (G) and Outer Pot (H) before installing Control Panel (A). Attach Control Panel & Element (A) onto Mounting Bracket (See Page 3 for mounting control panel & element).

**CAUTION:** Over tightening of screws can result in stripping of screw or cracking of handles or feet.

Save these instructions. In the event of a problem, call **1-800-489-1581**. You will need these part numbers.

### CONTROLLER UNIT PARTS

<b>A</b> Control Panel & Element	W00ETFCNTRL
<b>B</b> Break Away Cord	W00ETFCORD
<b>NON ELECTRIC PARTS</b>	
<b>C</b> Lid	W00ETFLID
<b>D</b> Lid Handle	W00ETFLHDL
<b>E</b> Bailing Basket	W00BSKT
<b>F</b> Drain Clip	
<b>G</b> Inner Pot	W00ETFIPT
<b>H</b> Outer Shield	W00ETFOPT
<b>I</b> Body Handles (2)	W00ETFBHDL
<b>J</b> Feet (6)	W00ETFEET
<b>K</b> Lifting Hook	W00ETFHOOK

### DEEP FRIED WHOLE TURKEY

Follow these simple steps for deep frying your turkey. **MAXIMUM RECOMMENDED TURKEY SIZE IS 14 POUNDS!**

1. Insure that the turkey is completely thawed, free of ice and water. Remove neck, giblet bag, plastic pop-up cooking indicator and leg ties. Pay special attention to inner cavity area.
2. Fill inner pot with oil to the fill line.
3. Set control dial to 400° (pre-heating time may take up to 55 minutes).
4. Place lid on the fryer.
5. While oil is pre-heating, prepare the turkey. Inject with a Southern Secrets Marinade of your choice and season the outside of the turkey with Southern Secrets Kickin' Cajun Rub.

### 6. CALCULATE COOKING TIME

The formula for calculating turkey cooking time is fry turkey 3 minutes per pound, then add 5 minutes to total cooking time:  
 13.86 lbs X 3 min    41.58 min  
 Plus 5 minutes    + 5.00 min  
 Total Cooking Time = 46.58 min

**NOTE:** Cooking conditions vary. Insert a food thermometer 2 1/2 inches in the deepest part of turkey and make sure a internal temperature of 180° is reached.

7. Heating indicator light will go OFF when temperature is reached.
8. Place turkey horizontally in basket, breast side up. See Graphic.
9. Wearing protective gloves or mitts, hook the basket handle with the lifting hook and very slowly lower the basket into the hot oil.



### DEEP FRIED TURKEY BREAST

Follow the above directions and safety precautions and adjust formula to 7 minutes per pound, then add 5 minutes to total cooking time.

### THAWING TURKEY

The National Turkey Federation recommends refrigerator thawing and to allow approximately 24 hours for every five pounds of bird thawed in the refrigerator.

10. With basket in place, cover with lid.
11. Set a kitchen timer or mark time.
12. Heating light will con on, indicating the element is heating. Be certain to cook for complete calculated time .
13. When time is up, turn the turkey fryer OFF and lift the basket from the hot oil slowly, hooking the basket to the side of the pot with the drain clip (See Page 5).
14. Carefully tilt the turkey up on one end to allow oil to drain out of the center cavity. The turkey can remain in the basket to cool until ready to serve.

### LOW COUNTRY BOIL (BOILING)

- 1 lb. shrimp • 1 lb. crawfish
- 1 lb. smoked sausage
- 8 pieces of short ear corn
- 2 bags of crab boil mix
- 2 lbs. of whole new potatoes

Fill inner pot with water to fill line and 2 bags of crab boil mix to the inner pot and bring water to a boil. Allow water to boil for 15 minutes and add sausage (cut sausage in 1/4-inc thick slices). Three minutes later, add potatoes; 3 minutes later, add corn; 3 minutes later, add shrimp and crawfish together; 3 minutes later, remove and serve.

### STEAMING INSTRUCTIONS

Add water till it reaches bottom of the bailing basket. Do not allow the water to evaporate. This will cause the element to overheat and can damage the unit.

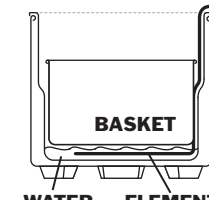

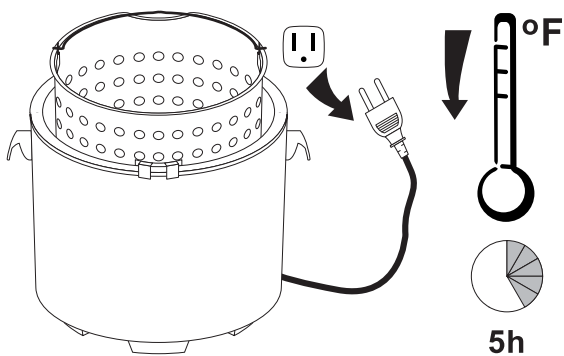

- Turn appliance off, unplug and let cool for 2 hours if using water, 5 hours if using oil before cleaning or storing.

**⚠ DANGER:** Disconnect electric cord from outlet, before cleaning, servicing and/or removing heating element. Electrical shock can result in personal injury or death.

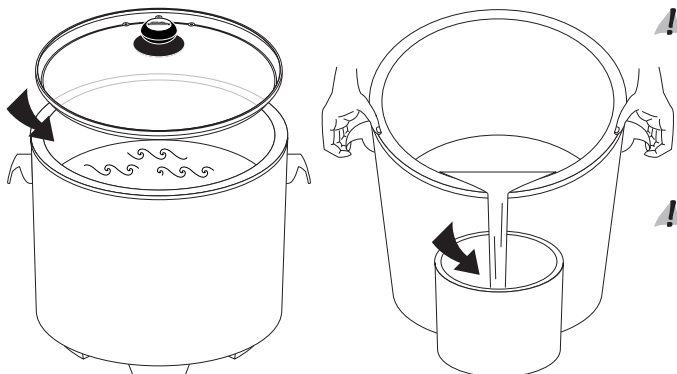

**⚠ CAUTION:** Do not pour used oil in the sink. Drain it into a receptacle.

**⚠ CAUTION:** Hold inner pot in with thumbs while pouring.

- Unused oil can be stored in appliance. Do not store water in appliance.

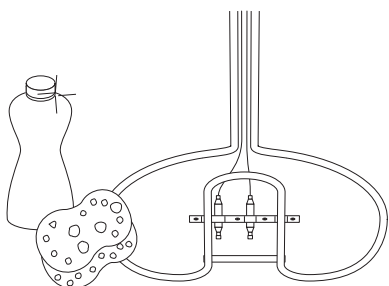

**⚠ WARNING:** Do not place fryer control panel under running water.

Immersing control panel and cord can cause electrocution.

- Clean plug, element and control panel with a damp cloth or sponge using a mild soap. All non-electric parts are dishwasher safe.
- When appliance is not in use, it must be unplugged from power supply.

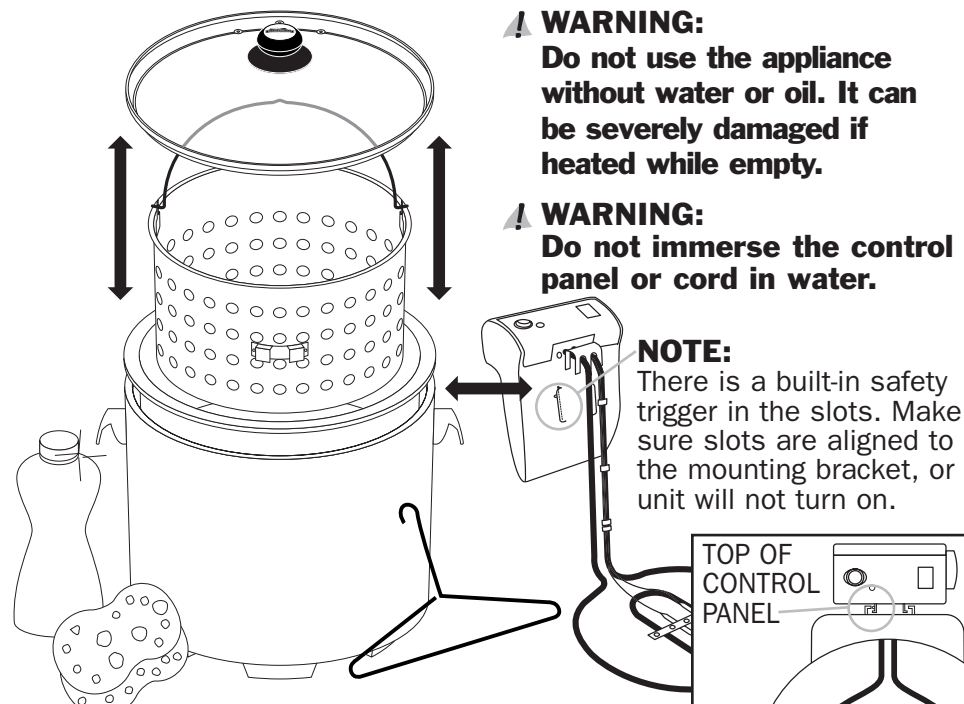

**⚠ WARNING:** Do not use the appliance without water or oil. It can be severely damaged if heated while empty.

**⚠ WARNING:** Do not immerse the control panel or cord in water.

- If desired, dismantle appliance for cleaning before initial use. Once unit is properly assembled, it can be used for frying, boiling and steaming.
- Clean the lid, inner pot, outer shield and basket with a damp cloth or sponge using a mild detergent. These parts can also be cleaned in the dishwasher.
- Clean cord, control panel and element with a damp cloth or sponge using a mild detergent. Never clean plug, cord, and control panel in the dishwasher.

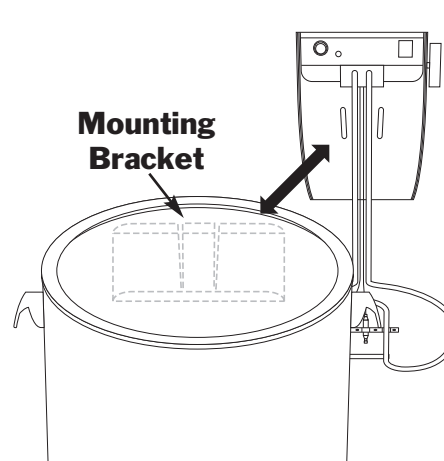

- Dry thoroughly.
- Attach Control Panel (A) to outer shield using mounting bracket.
- Make sure the Control Panel (A) is correctly attached or appliance will not work. There is a built-in safety switch in mounting bracket in the Control Panel (A).

## Using The Appliance

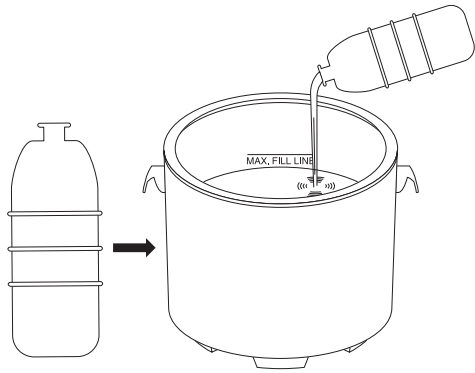

⚠ **WARNING:**  
Place unit on level and stable surface to prevent tipping.

⚠ **CAUTION:**  
Do not mix different types of oil at the same time.

**IMPORTANT:**  
It can take up to 55 min for unit to reach desired temp.

⚠ **CAUTION:**  
Never melt fat or lard on the heating element or in basket.

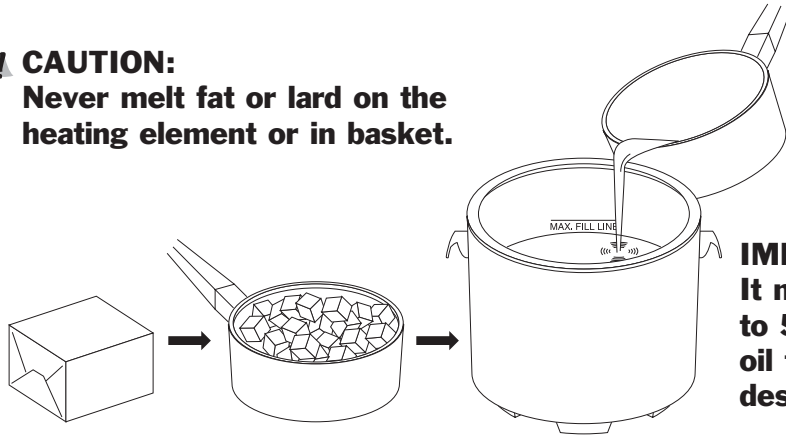

**IMPORTANT:**  
It may take up to 55 min for oil to reach desired temp.

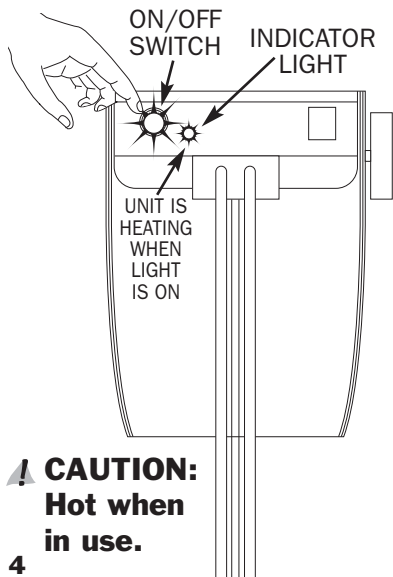

- Do not overfill past fill line. Boiling oil or water may overflow during use and cause severe injury.
- After inner pot is filled with oil or water, plug in 110V electric wall socket.
- Adjust to desired temperature.
- The indicator light will turn OFF when ready.
- Place food to be fried in basket. Never overfill.
- When indicator light turns OFF, slowly lower basket into oil or water and cover with lid. Always wear protective gloves or mitts.
- Temperature of the oil or water will drop when food is lowered into inner pot & indicator light will turn ON. Indicating the element is heating.

⚠ **CAUTION:**  
Hot when in use.

4

## Reset Function

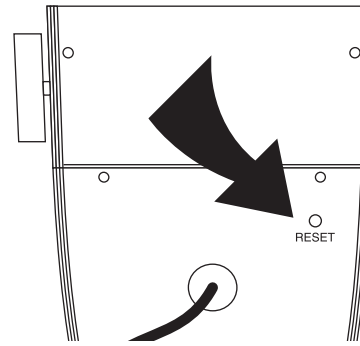

- Your appliance is equipped with an overheating security feature.
- If appliance overheats it will shut off automatically.
- To reset the appliance, press the button found on the back of the control panel.

## Serving

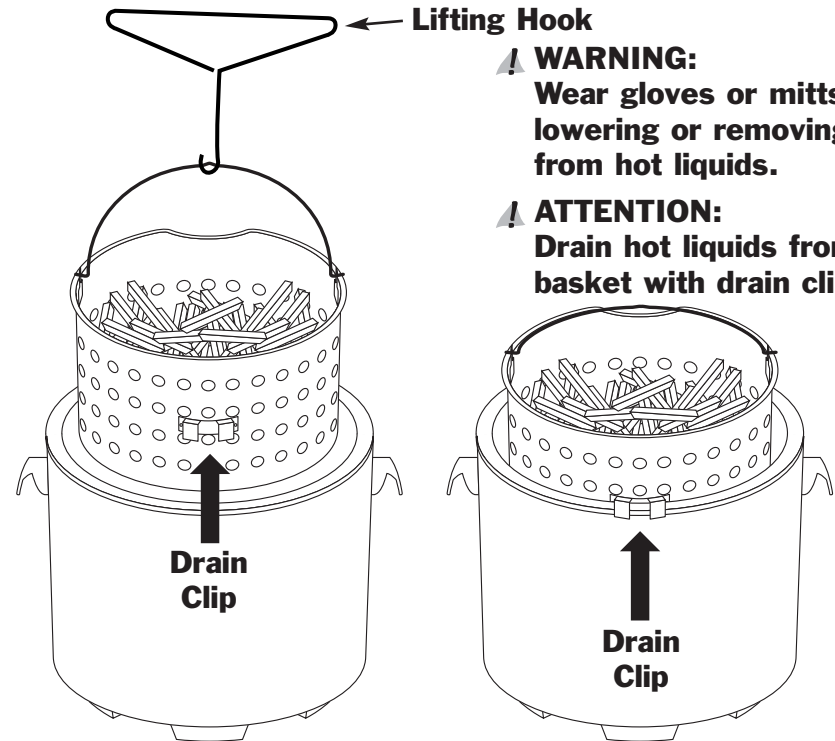

- ⚠ **WARNING:**  
Wear gloves or mitts when lowering or removing basket from hot liquids.
- ⚠ **ATTENTION:**  
Drain hot liquids from the basket with drain clip.

- When cooking time has elapsed and food is desired color, texture, turn the thermostat to lowest setting and turn off the power.
- Allow excess oil to drain by hooking basket on the inner pot with drain clip.
- It is best to season deep fried food immediately after frying.

5