



User's Manual

1.1 Cu. Ft. Stainless Steel Convection Microwave



Model: OTM1101VBS

TABLE OF CONTENTS

IMPORTANT SAFETY INSTRUCTIONS	3
INSTALLATION GUIDE	4
GROUNDING INSTRUCTIONS	5
PRODUCT DIAGRAM	5
CONTROL PANEL	6
OPERATION INSTRUCTIONS	7
SPECIAL FEATURES	9
COOKING UTENSILS GUIDE	14
COOKING TECHNIQUES	15
CLEANING AND CARE	17
BEFORE CALLING FOR SERVICE	18
SPECIFICATIONS	18

ATTENTION:

This microwave has a special convection cooking function. This is different from normal microwave cooking. When using the convection setting, cooking times and cooking processes differ. Please refer to the convection section of this manual (see page 8) for more information on convection cooking.

IMPORTANT SAFETY INSTRUCTIONS

READ ALL SAFETY INSTRUCTIONS BEFORE USING THIS MICROWAVE

When using electrical appliances, basic safety precautions should be followed, including the following:

1. Read all instructions before using the microwave.
2. This microwave must be grounded. Connect only to property grounded outlets.
3. Install or place this microwave only in accordance with installation instructions.
4. Some products, such as sealed glass jars, may explode and should not be heated in this microwave.
5. This microwave is intended for use only as described in this manual. Do not use corrosive chemicals or vapors in this microwave. This type of microwave is specifically designed to heat, cook, or dry foods. It is not designed for laboratory use.
6. As with any appliance, close supervision is necessary when used by children.
7. Do not overcook food. Carefully attend to the microwave when paper, plastic, or other combustible materials are placed inside the microwave to facilitate cooking.
8. Remove wire twist-ties from paper or plastic bags before placing in microwave.
9. If materials inside the microwave should ignite, keep microwave door closed, turn it off, and disconnect the power cord or turn off the power fuse at the circuit breaker panel.
10. Do not use the microwave cavity for storage purposes. Do not leave paper products, cooking utensils, or food in the cavity when not in use.
11. Liquids, such as water, coffee, or tea may overheat beyond the boiling point without appearing to be boiling due to surface tension of the liquid. Visible bubbling or boiling when the container is removed from the microwave is not always present. **THIS COULD RESULT IN VERY HOT LIQUIDS SUDDENLY BOILING OVER WHEN A SPOON OR OTHER UTENSIL IS INSERTED INTO THE LIQUID.** To reduce the risk of injury: do not overheat the liquid; stir the liquid both before and halfway through heating; do not use straight-sided containers with narrow necks; after heating, allow the container to stand in the microwave a short time before removing; use extreme care when inserting a spoon or other utensil into the container.
12. Do not heat oil or fat for deep-frying in this microwave. It is difficult to control the temperature of oil in the microwave.
13. Pierce foods with heavy skins, such as potatoes, before cooking.
14. The contents of feeding bottles and baby jars should be stirred or shaken and the temperature should be checked before serving to avoid burns.
15. Cooking utensils may become hot from heat transferred from the heated food. Pot holders may be needed to handle these utensils.
16. Do not cover or block any openings on the microwave.
17. Do not store or use this microwave outdoors. Do not use this microwave near water.
18. Do not operate this microwave if it has a damaged cord or plug, if it is not working properly, or if it has been damaged or dropped.
19. Do not immerse the cord or plug in water. Keep cord away from heated surfaces. Do not let the cord hang over the edge of the table or counter.
20. Use only thermometers specifically designed for microwaves.
21. Do not operate any heating or cooking under this microwave.
22. Be certain the tray and roller rings are in place when using the microwave.

IMPORTANT SAFETY INSTRUCTIONS (continued)

23. This microwave should be serviced only by qualified service personnel.
24. When cleaning microwave surface and door, use only mild, nonabrasive soaps or detergents applied with a sponge or soft cloth.

PRECAUTIONS TO AVOID POSSIBLE EXPOSURE TO EXCESSIVE MICROWAVE ENERGY

1. Do not attempt to operate this microwave with the door open. Door open operation can result in harmful exposure to microwave energy.
2. Do not place any objects between the microwave front face and the door, or allow soil or cleaner residue to accumulate on sealing surfaces.
3. Do not operate the microwave if damaged. It is particularly important that the microwave door be properly closed and there is no damage to the door, hinges and latches, or door seals and sealing surfaces.
4. The microwave should not be adjusted or repaired by anyone except properly qualified service personnel.

INSTALLATION GUIDE

1. Make sure all packing materials are removed from inside the microwave door.
2. Check the microwave for damage, such as misaligned or bent door, damaged door seals and sealing surface, broken or loose door hinges and latches, and dents inside the cavity or on the door. If there are any damages, do not operate the microwave and contact Customer Service at 1-866-866-6283.
3. This microwave must be placed on a flat, stable surface to hold its weight and the heaviest food likely to be cooked inside.
4. Do not place the oven where heat, moisture, or high humidity are generated. Do not place microwave near combustible materials.
5. For correct operation, the oven must have sufficient air flow. Allow 8" of space above the microwave, 4" at the back, and 2" on each side of the unit. Do not cover or block any openings on the microwave. Do not remove microwave feet.
6. Do not operate the oven without the tray, roller support, and shaft in their proper positions.
7. Make sure the power supply cord is undamaged and does not run under the microwave or over any hot or sharp surface.
8. The socket must be readily accessible so the microwave can be easily unplugged in an emergency.

GROUNDING INSTRUCTIONS

This microwave must be grounded. In the event of an electrical short circuit, grounding reduces risk of electric shock by providing an escape wire for the electric current.

WARNING: Improper use of the grounding plug can result in risk of electric shock.

ELECTRICAL REQUIREMENTS

- The electrical requirements for this microwave are a 120V, 60Hz, AC only, 20 amp.
- It is recommended that a separate circuit serving only the microwave be provided.
- The microwave is equipped with a 3-prong grounding plug. It must be plugged into a wall outlet properly installed and grounded.

POWER CORD

- A short power supply cord is provided to reduce the risks resulting from becoming entangled in or tripping over a long cord.
- Longer cord sets or extension cords are available and may be used if care is taken in using them.
- If using a longer cord, the marked electrical rating of the cord set or extension cord should be at least as great as the electrical marking of the microwave itself and the extension cord must be a grounded-type 3-wire cord. The longer cord should be arranged so it will not drape over the counter or tabletop.

PRODUCT DIAGRAM

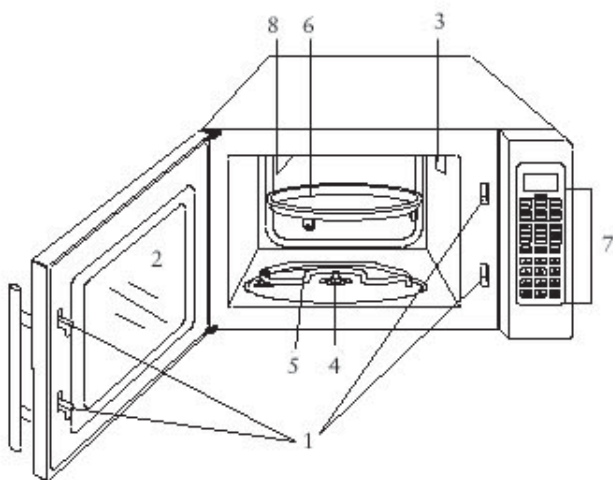

1. Door Safety Lock System
2. Microwave Window
3. Microwave Air Vent
4. Shaft
5. Bottom Grill
6. Roller Ring
7. Control Panel
8. Top Grill

CONTROL PANEL

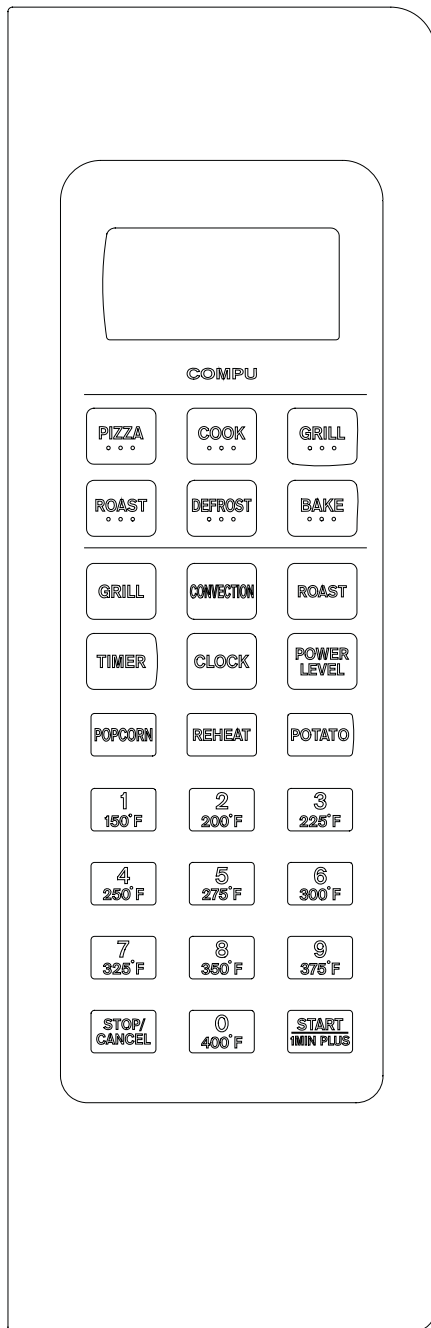

DISPLAY SCREEN: Cooking time, power, indicators, and present time are displayed.

COMPU COOKING: Instant settings to cook/defrost particular foods.

POWER LEVEL: Used to set cooking power level.

GRILL: Used to set a grill-cooking program.

CONVECTION: Used to set convection cooking

ROAST: Used to roast food.

TIMER: Timer functions independently, even while a cooking program is in progress.

COOK: Used for multi-staged cooking. Enables cooking at multiple power levels and time settings.

NUMBER PAD (0-9): Touch to set time or amount.

CLOCK: Sets current time.

START/1 MIN PLUS: Touch to start cooking or add cooking time.

STOP/CANCEL: Touch to stop cooking or clear previous settings.

NUMBER PADS/CONVECTION

TEMPERATURE ENTRY: Used to set cooking time, enter weight or number of servings, or program convection temperatures.

COOK SIGNALS

- One signal = microwave accepts entry.
- Two signals = microwave does not accept entry, check and try again.

OPERATION INSTRUCTIONS

SETTING THE CLOCK

1. Touch **CLOCK**.
2. Use the number pads to enter the correct time. You must touch at least three numbers to set the clock (one for the hour, two for the minutes).
3. Touch **CLOCK** again.

Notes:

- This is a 12-hour clock. When the microwave is first plugged in or when power resumes after a power outage, the display will show **ENTER CLOCK TIME**. If you prefer to not have the clock displayed, touch **RESET**.
- You can check the clock time while cooking is in progress by touching the **CLOCK** pad.

MICROWAVE COOKING

1. Touch **POWER LEVEL** the appropriate number of times to select the power level. (see chart below)
2. Use the number pads to enter the desired cook time.
3. Touch **START/1 MIN PLUS** to start cooking.

PRESS	POWER	DESCRIPTION
1 time	100%	High
2 times	90%	
3 times	80%	
4 times	70%	High Medium
5 times	60%	
6 times	50%	Medium
7 times	40%	
8 times	30%	Medium Low/Defrost
9 times	20%	
10 times	10%	Low
11 times	0%	

Notes:

- To temporarily stop cooking, press the **STOP/CANCEL** button once. To restart, press the **START/1 MIN PLUS** button. To completely cancel the cooking, press the **STOP/CANCEL** button twice.

OPERATION INSTRUCTIONS (continued)

GRILL

1. Touch GRILL the appropriate number of times to select the grill setting. (see chart below)
2. Use the number pads to enter the desired cook time.
3. Touch START/1 MIN PLUS to start cooking.

Press once	Top grill
Press twice	Top and bottom grill

CONVECTION

During convection cooking, hot air is circulated around the oven cavity to brown and crisp food evenly. This is different than using the normal microwave cooking function. Cooking times will vary.

1. Touch CONVECTION once.
2. Use the number pads to enter the desired temperature and then to enter the desired cook time.
3. Touch START/1 MIN PLUS to start cooking.

Please note the fan will continue to run after the cooking cycle is complete to cool the microwave.

Notes:

- To preheat microwave before convection cooking, follow the above steps with the microwave cavity empty and set the temperature to 200°F. The microwave will beep when the program has completed. The microwave is then preheated.
- To check the convection cooking temperature while cooking is in progress, press CONVECTION.

ROAST

1. Touch ROAST button and then the appropriate number pad to select the roast setting. (see chart below)
2. Use the number pads to enter the desired cook time.
3. Touch START/1 MIN PLUS to start cooking.

PROGRAM	PRESS	TEMP (°F)
COMB1	1	250
COMB2	2	300
COMB3	3	350
COMB4	4	400

SPECIAL FEATURES

POPCORN

1. Touch POPCORN. CODE and cooking time appears in the display. POPCORN automatically sets the cooking time for a 3-3.5 oz bag of microwave popcorn.
2. Touch START/1 MIN PLUS.

Note:

- To change the preset POPCORN time: touch POPCORN twice. ENTER TIME appears on the display. Touch the number pads to enter minutes and seconds. Touch START/1 MIN PLUS. This new cooking time will remain whenever you use the POPCORN setting.

POTATO

For 3.5-5 oz potatoes:

1. Touch POTATO.
2. Enter the number of potatoes by touching the number pads 1-4.
3. Touch START/1 MIN PLUS.

For 6-8 oz potatoes:

1. Touch POTATO twice.
2. Enter the number of potatoes by touching the number pads 1-4.
3. Touch START/1 MIN PLUS.

REHEAT

1. Touch REHEAT. CODE and cooking time appear on the display.
2. Touch START/1 MIN PLUS.

SPECIAL FEATURES (continued)

COMPU PIZZA

1. Touch PIZZA the appropriate number of times to select the pizza setting. (see chart below)
2. Press START/1 MIN PLUS to start cooking.

Press PIZZA	Setting Food	Quantity
1 time	1. Bake frozen pizza, regular crust	1
2 times	2. Bake frozen pizza, rising crust	1
3 times	3. Bake refrigerated pizza	1
4 times	4. Microwave pizza	1
5 times	5. Reheat pizza*	1-6 slices

* When reheating pizza, enter the cook time and press START/1 MIN PLUS

COMPU COOK

1. Touch COOK the appropriate number of times to select the food setting. (see chart below)
2. Press START/1 MIN PLUS to start cooking.

During cooking, you may hear beeps telling you to turn food over for even cooking.

Press COOK	Items	Amount
1 time	1. Baked potato	1-4 medium
2 times	2. Fresh vegetables	1-4 cups
3 times	3. Frozen vegetables	1-4 cups
4 times	4. Ground meat*	0.3-1.5 pounds
5 times	5. Seafood, fish*	0.3-1.5 pounds

* For ground meat and fish, enter the weight when asked by using the number pads.

SPECIAL FEATURES (continued)

COMPU DEFROST

1. Touch DEFROST the appropriate number of times to select the food setting. (see chart below)
2. Use the number pads to enter food weight.
3. Press START/1 MIN PLUS to start cooking.

To defrost other foods, use 30% power and program defrosting time.

Press COOK	Items	Amount
1 time	1. Ground meat	0.5-3.0 pounds
2 times	2. Steaks, chops, fish	0.5-3.0 pounds
3 times	3. Chicken pieces	0.5-3.0 pounds
4 times	4. Roast	2.0-4.0 pounds
5 times	5. Casserole	2-6 cups

COMPU GRILL

1. Touch GRILL the appropriate number of times to select the food setting. (see chart below)
2. Use the number pads to enter food weight.
3. Press START/1 MIN PLUS to start cooking.

During cooking, you may hear beeps telling you to turn food over for even cooking.

Press GRILL	Food Setting	Quantity
1 time	1. Hamburgers	1-7 (0.25 pounds each)
2 times	2. Steaks	0.5-2.0 pounds
3 times	3. Fish steaks	0.5-2.0 pounds
4 times	4. Boneless poultry	0.5-2.0 pounds
5 times	5. Chicken pieces	0.5-3.0 pounds

SPECIAL FEATURES (continued)

COMPU ROAST

1. Touch ROAST the appropriate number of times to select the food setting. (see chart below)
2. Use the number pads to enter food weight.
3. Press START/1 MIN PLUS to start cooking.

During cooking, you may hear beeps telling you to turn food over for even cooking.

Press ROAST	Food Setting	Quantity
1 time	1. Chicken, turkey (whole)	2.5-7.0 pounds
2 times	2. Pork loin	2.0-3.5 pounds
3 times	3. Turkey breast	3.0-6.0 pounds
4 times	4. Beef eye or round	2.0-4.0 pounds
5 times	5. Cornish hen	1.0-6.5 pounds

COMPU BAKE

1. Touch BAKE the appropriate number of times to select the food setting. (see chart below)
2. Use the number pads to enter food weight.
3. Press START/1 MIN PLUS to start cooking.

Press BAKE	Food Setting	Quantity
1 time	1. French fries	0.3-1.0 pounds
2 times	2. Frozen snack	number on turntable
3 times	3. Brownies	8" x 8" x 2"
4 times	4. Snack cake	8" x 8" x 2"
5 times	5. Biscuits	8-10 (from packaged convenience biscuits)

- When cooking takes place for items 3 and 4 in the above chart, the microwave will first preheat to 350°F before reminding you to place food into the microwave cavity.
- When cooking takes place for item 5, the microwave will first preheat to 400°F before reminding you to place food into the microwave cavity.
- If the preheat temperature is reached but food is not placed into the microwave cavity shortly thereafter, the temperature will decrease and preheat again.

SPECIAL FEATURES (continued)

ADD COOK TIME

For non-pre-programmed cooking, you can add cook time by pressing START/1 MIN PLUS. The cook time increases by one minute per touch.

SETTING MICROWAVE TIMER

1. Touch TIMER.
2. Enter the amount of time by touching the number pads.
3. Touch START/1 MIN PLUS

Notes:

- The time countdown can be seen in display for three seconds before clock or cooking time is returned to the display.
- Touch TIMER and then RESET to cancel timer during process.

SETTING CHILD LOCK

The safety lock prevents unsupervised operation by children.

- To set, press and hold RESET for three seconds. LOCK is indicated on the display.
- To cancel, press and hold RESET for three seconds. LOCK indication disappears.

AUTOMATIC PROTECTION MECHANISM

- Anytime while the microwave is in use, if the microwave reaches a temperature of 525°F, the microwave will automatically enter into self-protection mode beeping every 1.5 seconds until the temperature drops and STOP/CANCEL is pressed to bring the microwave back to normal.
- During grilling of combination cooking, when the temperature of the oven is lower than 104°F after cooking has taken place for 5 minutes, the oven will automatically enter into self-protection mode and the screen will display error code E 02. The error message will disappear when you press STOP/CANCEL.
- Error may also occur to the system sensor, which will make the microwave enter self-protection mode and display error code E 04 and beep. Press STOP/CANCEL to stop.

COOKING UTENSILS GUIDE

This section lists which utensils can be used in this microwave, which have limited use for short periods, and which should not be used in this microwave.

RECOMMENDED

Microwave browning dish -- Use to brown the exterior of small items such as steaks, chops, or pancakes. Follow the directions provided with your browning dish.

Microwaveable plastic wrap -- Use to retain steam. Leave a small opening for some steam to escape and avoid placing it directly on the food.

Paper towels and napkins -- Use for short-term heating and covering; these absorb excess moisture and prevent splattering. Do not use recycled paper towels which may contain metal and could ignite.

Glass and glass-ceramic bowls and dishes -- Use for heating and cooking.

Paper plates and cups -- Use for short-term heating at low temperatures. Do not use recycled paper which may contain metal and could ignite.

Wax paper -- Use as a cover to prevent splattering.

Thermometers -- Use only those labeled “Microwave Safe” and follow all directions. Check the food in several places. Conventional thermometers may be used on microwaved food once the food has been removed from the microwave.

LIMITED USE

Aluminum foil -- Use narrow strips of foil to prevent overcooking exposed areas. Using too much foil can damage your microwave, so be careful. Keep 1” between foil and microwave cavity.

Ceramic, porcelain, and stoneware -- Use these if they are labeled “Microwave Safe”. If they are not labeled, test them to make sure they can be used safely.

Plastic -- Only use if labeled “Microwave Safe”. Other plastics may melt.

COOKING UTENSILS GUIDE (continued)

NOT RECOMMENDED

Glass jars and bottles -- Regular glass is too thin to be used in a microwave. It can shatter and cause damage and injury.

Paper bags -- These are a fire hazard, except for popcorn bags that are designed for microwave use.

Styrofoam plates and cups -- These can melt and leave unhealthy residue on food.

Plastic storage and food containers -- Containers such as margarine tubs can melt in the microwave.

Metal utensils -- These can damage your microwave. Remove all metal before cooking.

Note:

- Should you wish to check if a dish is safe for microwaving, place the empty dish in the microwave and microwave on high for 30 seconds. A dish that becomes very hot should not be used.

COOKING TECHNIQUES

Your microwave makes cooking easier than conventional cooking, provided you keep these considerations in mind:

STIRRING

- Stir foods such as casseroles and vegetables while cooking to distribute heat evenly.
- Food at the outside of the dish absorbs more energy and heats quicker, so stir from the outside to the center.
- The microwave will turn off when you open the door to stir your food.

ARRANGEMENT

- Arrange evenly shaped foods, such as chicken pieces or chops, with the thicker, meatier parts towards the outside of the turntable where they receive more microwave energy.
- To prevent overcooking, place delicate areas, such as asparagus tips, towards the center of the turntable.

COOKING TECHNIQUES (continued)

SHIELDING

- Shield food with narrow strips of aluminum foil to prevent overcooking.
- Areas that need shielding include poultry wing tips, the ends of poultry legs, and corners of square baking dishes.
- Use only small amounts of aluminum foil, as larger amounts may damage your microwave.

TURNING

- Turn foods over midway through cooking to expose all parts to microwave energy.
- This is especially important when cooking large foods such as roasts.

STANDING

- Foods cooked in a microwave build up internal heat and continue to cook for a few minutes after heating stops.
- Let foods stand to complete cooking, especially for foods such as cakes and whole vegetables.
- Roasts need this time to complete cooking in the center without overcooking the outer areas.
- All liquids, such as soup or hot chocolate, should be shaken or stirred when cooking is complete.
- When heating baby food, stir well after removing from microwave and test temperature before serving.

ADDING MOISTURE

- Microwave energy is attracted to water molecules.
- Food that is uneven in moisture content should be covered or allowed to stand so that the heat disperses evenly.
- Add a small amount of water to dry food to help it cook.

CLEANING AND CARE

1. Turn off the microwave and unplug the power cord from the wall when cleaning.
2. Keep the inside of the microwave clean. When food splatters or spilled liquids adhere to microwave walls, wipe with a damp cloth. Mild detergents may be used if the microwave gets very dirty. Avoid using spray or other harsh cleaners may stain, streak, or dull the door surface.
3. The outside of the microwave should be cleaned with a damp cloth. To prevent damage to the operating parts inside the microwave, water should not be allowed to seep into the ventilation openings.
4. Wipe the window on both sides with a damp cloth to remove any spills or splatters.
5. Do not allow the control panel to become wet. Clean with a soft, damp cloth. When cleaning the panel, leave the microwave door open to prevent it from accidentally turning on.
6. If steam accumulates inside or around the outside of the door, wipe with a soft cloth. This may occur when the microwave is operated under high humidity. This is normal.
7. It may be necessary to remove the tray for cleaning. Wash the tray in warm, soapy water or in a dishwasher.
8. The roller ring and microwave floor should be cleaned regularly to avoid excessive noise. Wipe the bottom surface of the microwave with a mild detergent. The roller ring may be washed in mild, soapy water or in a dishwasher. When removing the roller ring, be sure to replace it in the proper position.
9. Remove odors from your microwave by combining a cup of water with the juice and skin of one lemon in a microwaveable bowl. Microwave for 5 minutes. Wipe thoroughly and dry with a soft cloth.
10. If the light bulb burns out, please contact customer service (1-866-866-6283) to have it replaced.
11. The microwave should be cleaned regularly and any food deposits should be removed. Failure to maintain the microwave in a clean condition could lead to deterioration of surfaces that could adversely affect the life of the unit and could possibly result in a hazardous situation.
12. Please do not dispose of this appliance into a regular garbage receptacle. Please check to see where you can dispose such appliances.

BEFORE CALLING FOR SERVICE

Before asking for service, please check each item below:

- Check to ensure the microwave is plugged in securely. If not, remove the plug from the outlet, wait 10 seconds, and plug it in again securely.
- Check for a blown circuit fuse or a tripped main circuit breaker. If these seem to be operating properly, test the outlet with another appliance.
- Check to ensure the control panel is programmed correctly and the timer is set.
- Check to ensure the door is securely closed, engaging the door safety lock system. If the door is not properly closed, the microwave energy will not flow inside.

SPECIFICATIONS

Power Consumption	120 V, 60 Hz, 1450 W (Microwave) 120 V, 1350 W (Convection) 120 V, 1350 W (Top and Bottom Grill)
Output	1000W
Operation Frequency	2450 MHz
Outside Dimensions (H x W x D, inches)	12 x 21 x 19
Microwave Cavity Dimensions (H x W x D, inches)	9 x 14 x 14
Microwave Capacity	1.1 Cu. Ft.
Cooking Uniformity	Turntable System (Φ 11”)
Net Weight (pounds)	Approx. 34.4



© 2007 Sunbeam Products, Inc. doing business as Jarden Consumer Solutions. All rights reserved.
Oster® is a registered trademark of Sunbeam Products, Inc. used under license.
Distributed by Petters Consumer Brands, LLC. 4400 Baker Road, Minnetonka, MN 55343.

For service, support and warranty information, in the US call 1-866-866-6283.