

PASSEGGINO S3

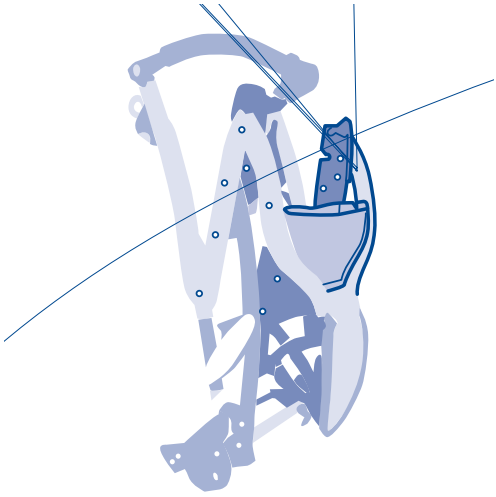

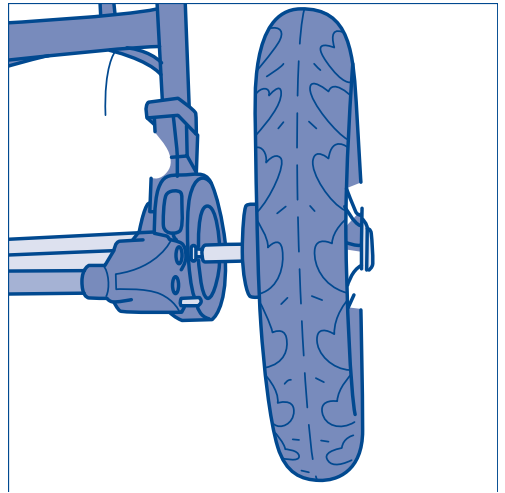

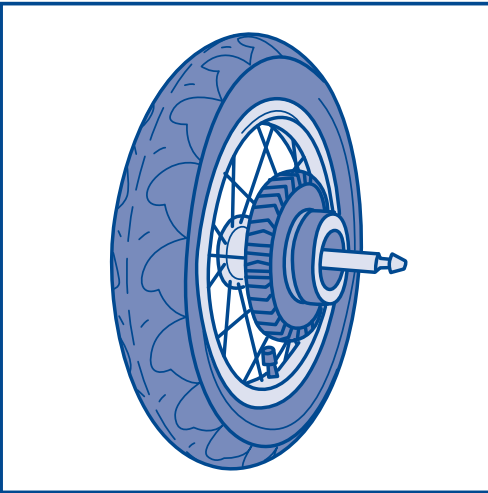

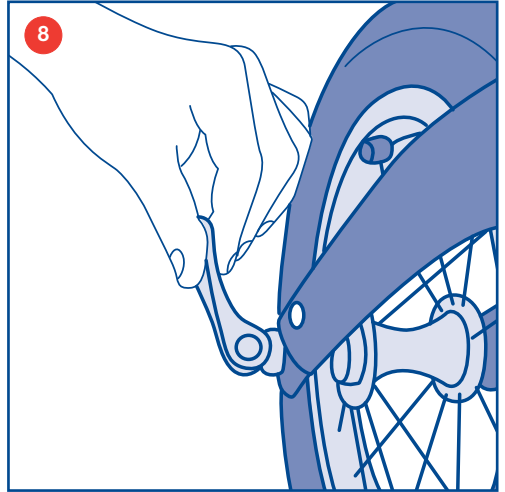
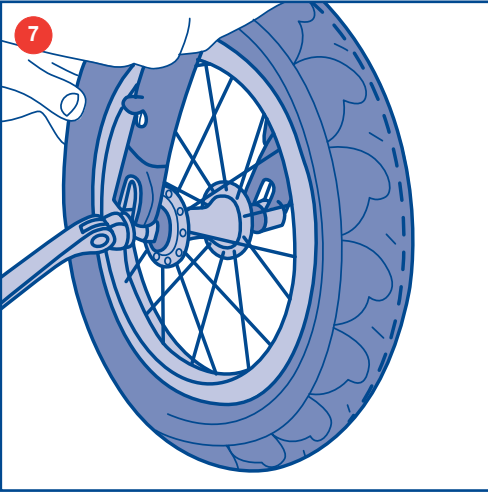
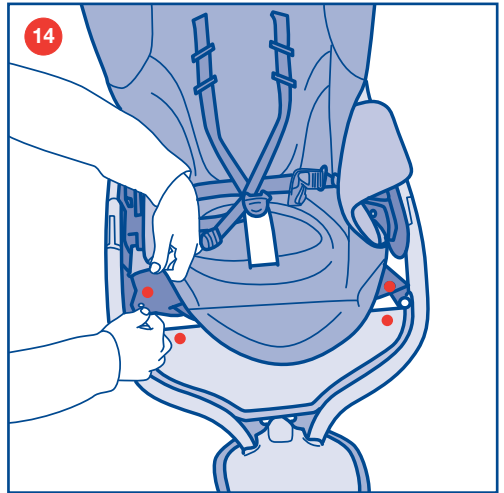
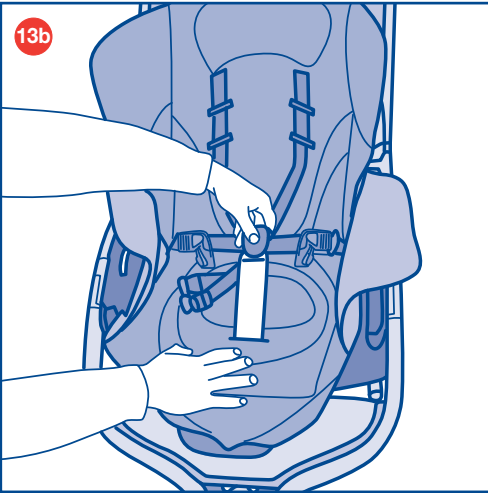
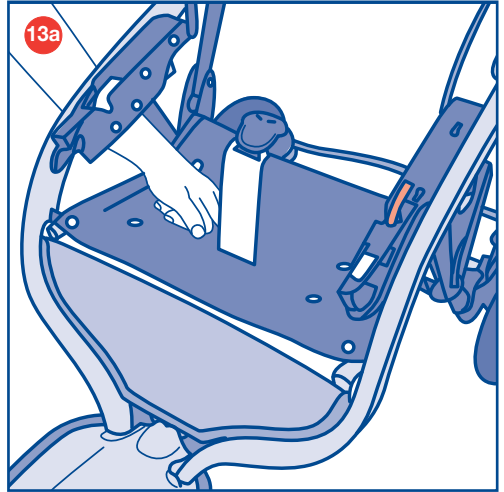
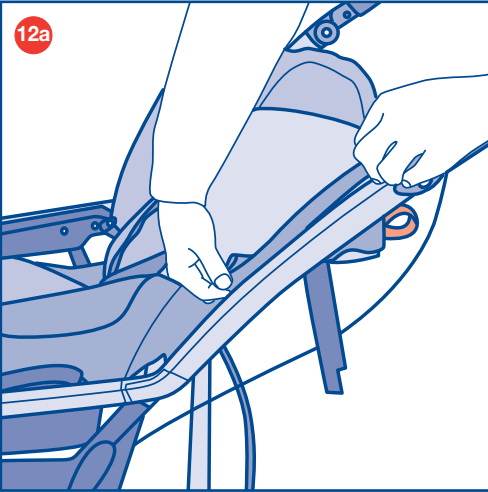

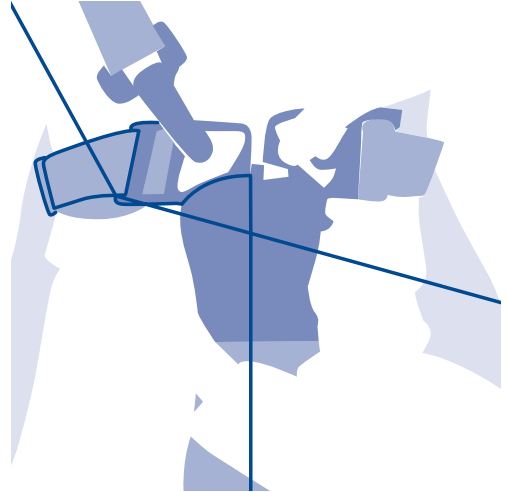
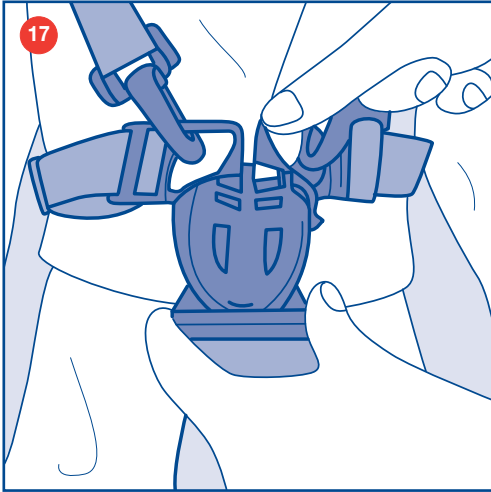

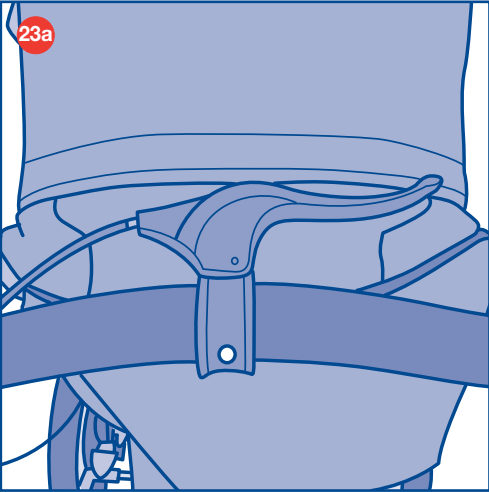

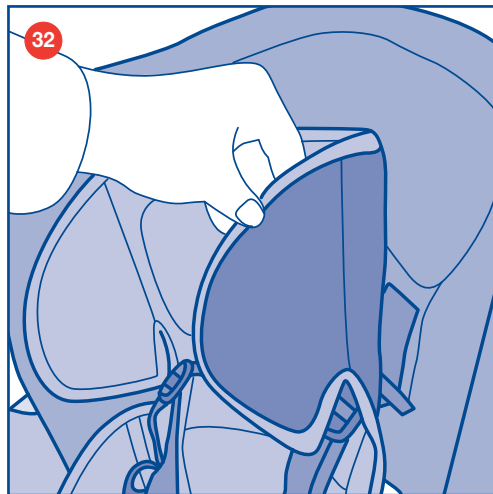
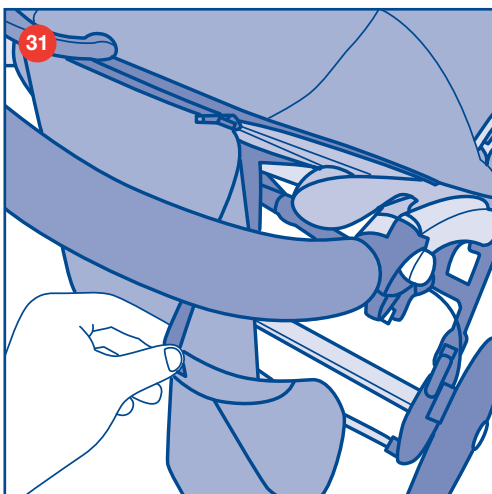
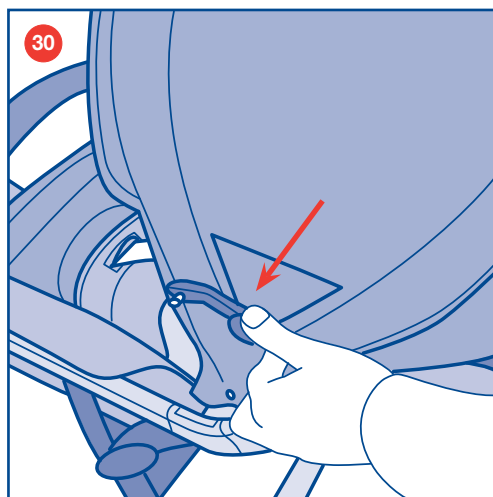
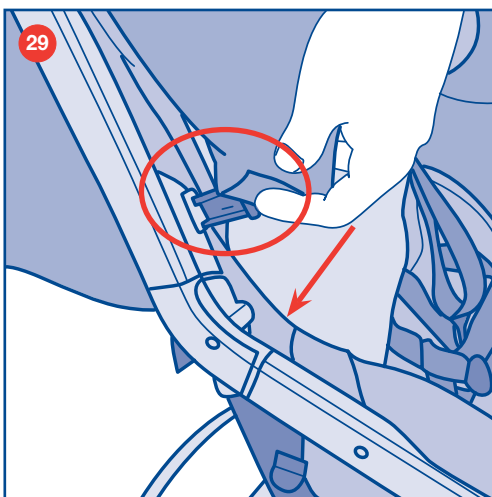
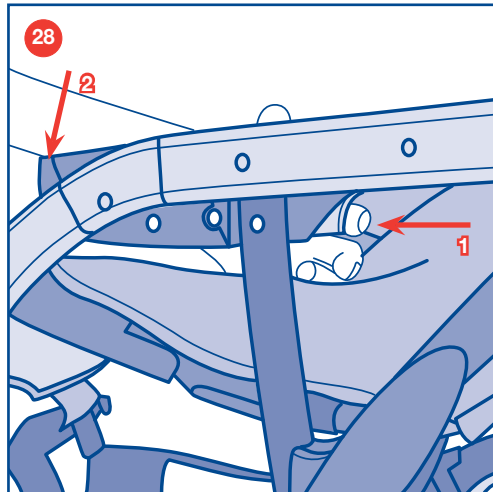
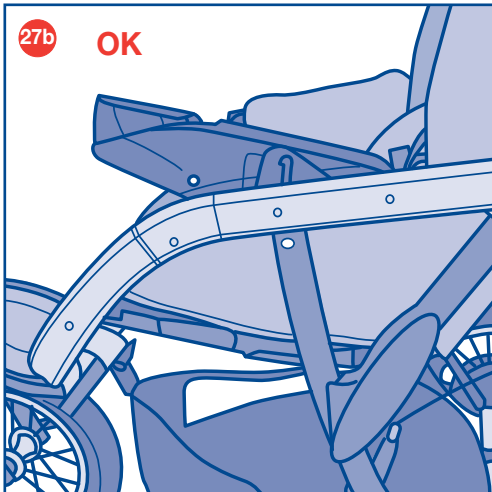

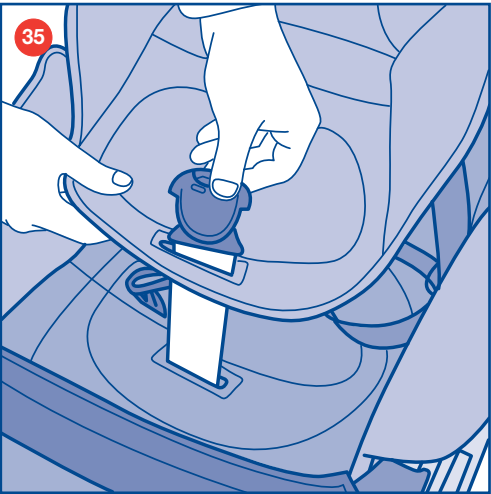
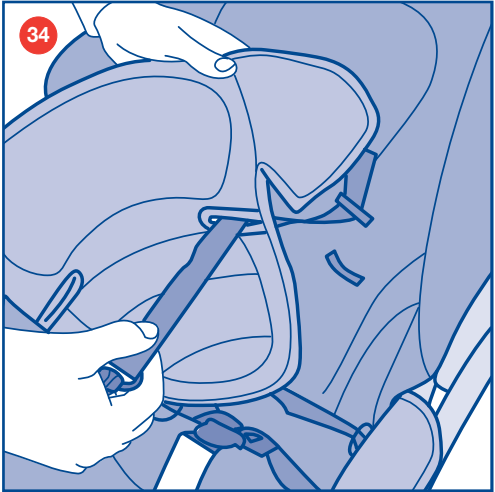

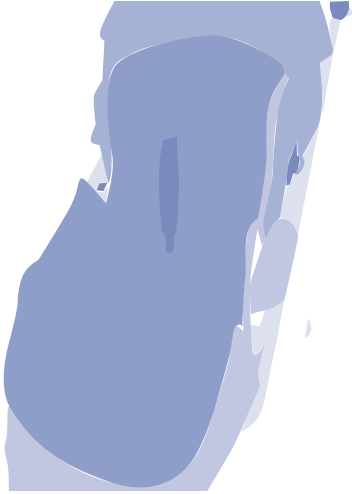

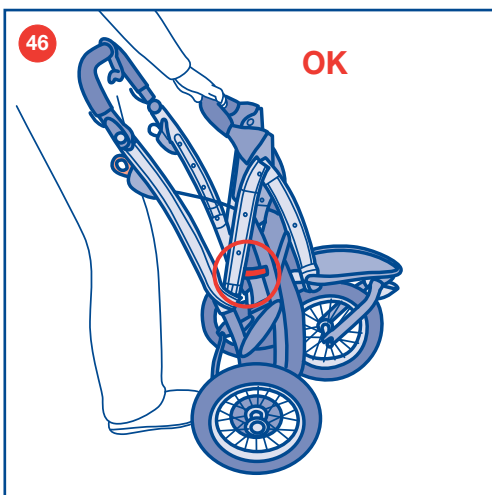
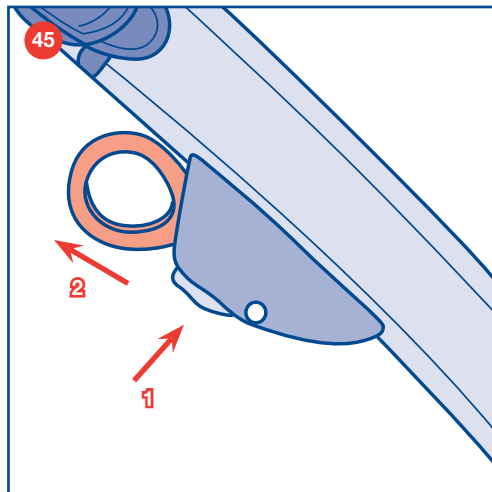
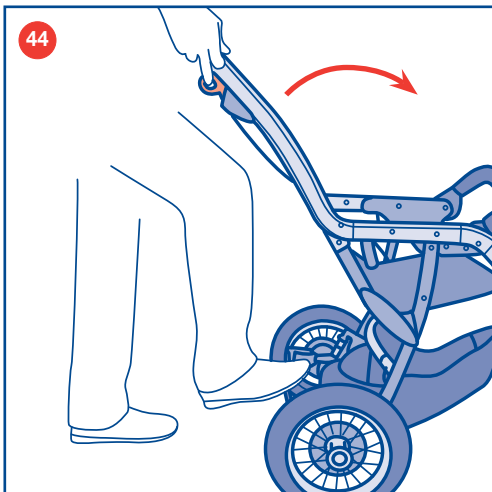

I IMPORTANTE: PRIMA DELL'USO LEGGERE ATTENTAMENTE QUESTO LIBRETTO D'ISTRUZIONI PER EVITARE PERICOLI NELL'UTILIZZO E CONSERVARLO PER OGNI FUTURO RIFERIMENTO. PER NON COMPROMETTERE LA SICUREZZA DEL VOSTRO BAMBINO SEGUITE ATTENTAMENTE QUESTE ISTRUZIONI

F IMPORTANT: LIRE ATTENTIVEMENT CE LIVRET D'INSTRUCTIONS AFIN D'EVITER TOUT DANGER D'UTILISATION ET LE CONSERVER EN VUE D'UNE EVENTUELLE CONSULTATION FUTURE. POUR NE PAS FAIRE COURIR DE RISQUES A VOTRE ENFANT, RESPECTER SCRUPULEUSEMENT CES INSTRUCTIONS

D WICHTIG: VOR DEM GEBRAUCH AUFMERKSAM DIESE ANLEITUNG LESEN, UM GEFAHREN BEI DER BENUTZUNG ZU VERMEIDEN UND FÜR ZUKÜNFTIGES NACHSCHLAGEN AUFBEWAHREN. BEFOLGEN SIE SORGFÄLTIG DIESE ANLEITUNG, DAMIT DIE SICHERHEIT IHRES KINDES NICHT BEEINTRÄCHTIGT WIRD

**USA
GB** IMPORTANT: RETAIN FOR FUTURE REFERENCE - READ CAREFULLY - YOUR CHILD'S SAFETY MAY BE AFFECTED IF YOU DO NOT FOLLOW THESE INSTRUCTIONS CAREFULLY.

E IMPORTANTE: ANTES DEL USO LEA ATENTAMENTE ESTE MANUAL DE INSTRUCCIONES PARA EVITAR PELIGROS Y CONSERVELO PARA FUTURAS CONSULTAS. PARA NO COMPROMETER LA SEGURIDAD DE SU BEBÉ, SIGA ATENTAMENTE ESTAS INSTRUCCIONES.

P IMPORTANTE: PARA EVITAR ACIDENTES DURANTE A UTILIZAÇÃO, ANTES DE UTILIZAR O PRODUTO, LEIA, ATENTAMENTE ESTE LIVRO DE INSTRUÇÕES E CONSERVE-O PARA CONSULTAS FUTURAS. A SEGURANÇA DO SEU FILHO PODE ESTAR EM PERIGO SE NÃO SEGUIR, ATENTAMENTE, ESTAS INSTRUÇÕES

NL BELANGRIJK: LEES DEZE GEBRUIKSAANWIJZINGEN VÓÓR HET GEBRUIK GOED DOOR OM GEVAREN TIJDENS HET GEBRUIK TE VOORKOMEN EN BEWAAR ZE VOOR LATERE RAADPLEGING. VOLG DEZE GEBRUIKSAANWIJZINGEN NAUWKEURIG OM DE VEILIGHEID VAN JE KIND NIET IN GEVAAR TE BRENGEN

DK VIGTIGT: INDEN PRODUKTET TAGES I ANVENDELSE, SKAL DENNE BRUGSANVISNING GENNEMLÆSES NØJE FOR AT UNDGÅ FARE UNDER ANVENDELSEN. BRUGSANVISNINGEN SKAL OPBEVARES MED HENBLIK PÅ AL FREMTIDIG REFERENCE. FOR IKKE AT LADE DET GÅ DU OVER JERES BARN'S SIKKERHED, SKAL DISSE ANVISNINGER FØLGES MEGET NØJE.

FIN TARKEÄÄ: ENNEN KÄYTTÖÄ LUE NÄMÄ OHJEET TARKKAAN JA NOUDATA NIITÄ HUOLELLISESTI, JOTTA ET VAARANTAISI LAPSESI TURVALLISUUTTA. SÄILYÄ OHJEET TULEVAÄ TARVETTA VARTEN.

S VIKTIGT: INNAN ANVÄNDNINGEN SKA DENNA BRUKSANVISNING LÄSAS NOGA FÖR ATT UNDVIKA FAROR VID ANVÄNDNINGEN. BEVÅRA BRUKSANVISNINGEN FÖR FRAMTIDA BRUK. FÖLJ NOGA INSTRUKTIONERNA FÖR ATT INTE ÄVENTYRA DITT BARN'S SÄKERHET

N VIKTIG: LES NØYE DENNE HÅNDBOKEN FØR BRUK FOR Å UNNGÅ FARER VED ANVENDELSE OG OPPBEVAR DEN TIL ALLE SENERE INFORMASJONER. DERE KAN KOMPROMITTE BARETS SIKKERHET HVIS DERE IKKE FØLGER NØYE DISSE INSTRUKSJONENE.

CS D LEŽITÉ: P ED POUŽITÍM SI POZORN PRO T TE TENTO NÁVOD, ABYSTE SE VYHNULI MOŽNÝM NEBEZPE ĀMA USCHOVEJTE JEJ PRO DALŠÍ POUŽITÍ. I TE SE P ESN POKYNY UVEDENÝMI V TOMTO NÁVODU, ABYSTE NEOHROZILI BEZPE NOST VAŠEHO DÍT TE.

PL WA NE: PRZED PRZYST PIENIEM DO U YTKOWANIA PRODUKTU, PROSZ UWA NIE PRZECZYTA NINIEJSZ INSTRUKCJ , ABY BEZPIECZNIE SI NIM POSŁUGIWA . ZACHOWA INSTRUKCJ NA PRZYSZŁO . ABY ZAPEWNI BEZPIECZE STWO WASZEMU DZIECKU, NALE Y DOKŁADNIE STOSOWA SI DO NINIEJSZEJ INSTRUKCJ.

GR

WARNINGS

IMPORTANT: PLEASE READ THESE INSTRUCTIONS CAREFULLY BEFORE USE AND KEEP THEM FOR FUTURE REFERENCE.

CAUTION: BEFORE USE, REMOVE AND DISPOSE OF ALL PLASTIC BAGS AND PACKAGING MATERIALS AND KEEP THEM OUT OF REACH OF CHILDREN.

WARNINGS

WARNING: Children should be harnessed in at all times and should never be left unattended.

WARNING: Before assembly, check that the product and all of its components have not been damaged during transportation. Should any part be damaged, do not use and keep out of reach of children.

This stroller is intended for use for children aged between 6 and 36 months of age, and weighing up to 15 kg.

WARNING: This stroller is not suitable for children from birth to 6 months of age.

WARNING: Before use, ensure that all the safety devices are correctly fitted and working. In particular, ensure that the stroller is locked in the open position, by checking that the two sides are correctly locked into position.

Do not overload the storage basket. Maximum weight 3 kg.

Do not carry more than one child at a time.

Do not use accessories, spare parts, or any component not supplied or approved by the manufacturer as they may make the stroller unsafe.

Overloading, incorrect folding and the use of non-approved accessories may damage or break this stroller.

WARNING: Do not attach any items to the handles, this may affect the stability of the stroller.

WARNING: The use of the crotch strap and safety harness is necessary to guarantee the safety of your child. Always use the safety harness together with the crotch strap.

Ensure that the person using the stroller knows how to use it safely.

Do not attempt to open or close the stroller with a child on board.

WARNING: When opening, adjusting or closing the stroller, ensure that your child is at a safe distance: ensure that during these operations, the movable parts of the stroller do not come into contact with your child.

Always apply the brakes whenever the stroller is stationary. **WARNING:** never leave the stroller on a sloped surface with a child on board, even with the brakes applied.

Do not let other children play unattended close to the stroller or climb on it.

If the stroller is left exposed to direct sun light for a long time, allow it to cool before placing your child in it. Prolonged exposure to direct sunlight may cause the fabric to fade.

Do not use the product if some of its parts are broken,

torn or missing.

WARNING: When it is not used, the stroller must be kept away from the reach of children.

WARNING: The stroller must not be used while running or skating.

WARNING: Do not use the rain cover if the stroller is not fitted with the hood or sun canopy to prevent the risk of suffocation.

WARNING: To prevent the risk of overheating, never leave the stroller under the sun with the child seated in it if the rain cover is fitted to the stroller.

Prevent the stroller from coming into contact with salt water. It may cause the formation of rust.

Do not use the stroller on the beach.

CLEANING AND MAINTENANCE

This product requires regular maintenance.

The cleaning and maintenance of the stroller must only be carried out by an adult.

CLEANING

To remove the cover of the stroller and the rigid backrest support, please refer to the section "how to fit/remove the cover".

Please refer to the care label for instructions on cleaning the fabric parts of the stroller.

Periodically wipe clean plastic parts with a soft damp cloth.

Always dry the metal parts to prevent the formation of rust if the stroller has come into contact with water.

MAINTENANCE

Lubricate the moving parts only if necessary, with a light application of a silicone based lubricant.

Periodically check the condition of the wheels, and keep them clean of dust and sand.

Is the stroller has inflatable wheels, check their pressure regularly and, if necessary, pump them with the pump supplied (check the pressure of the wheels also before using the stroller the first time). In case of a flat tyre, the pneumatic may be mended with a bicycle repair kit.

WARNING: Do not exceed the maximum pressure indicated on the pneumatic. **WARNING:** Do not use compressors to pump the wheels.

WARNING! After having inflated the tyres, ensure that the small plastic valve caps are screwed tightly onto the valve, since they are small parts that can be swallowed.

Keep the stroller in a dry place.

GENERAL INSTRUCTIONS

WARNING: When assembling, disassembling opening or closing the stroller, ensure that your child, or other children, are at a safe distance. Ensure that during these operations the movable parts of the stroller do not come into contact with your child.

HOW TO OPEN THE STROLLER

1. After removing the frame from the package, the stroller will look as shown in diagram 1.
2. Before opening the frame, release the locking device located at the right side, as shown in diagram 2.

3. Raise the stroller as shown in diagram 3; the stroller will start to open.

WARNING: Before use, ensure that the stroller is locked in the open position, checking that the locking devices located at the sides are locked.

HOW TO OPEN/CLOSE THE FRONT FOOTREST

The stroller is supplied with the front footrest closed, to make the stroller more compact.

WARNING: Lock the footrest in the use position immediately after opening the stroller (please refer to the paragraph: "How to open the stroller").

4. Turn the footrest as shown in diagram 4.

5. Open the locking device located at the rear of the footrest, then align the hole located on the footrest to the locking joint, and slide the joint until it is safely locked, as shown in diagram 5.

WARNING: Check that the footrest is locked in the use position.

To make the stroller more compact when closed, after removing the front wheel, fold the footrest, carrying out the above operations in the reverse order.

HOW TO FIT/REMOVE THE FRONT WHEEL

6. The front wheel is different from the other wheels because it has a rapid removal system similar to the system used by cyclists (diagram 6).

7. Insert the joint of the wheels into the correct slots located at the end of the front fork, as shown in diagram 7; Check that the axis of the wheel is correctly inserted to the end of both sides of the fork.

8. After fitting the wheel, tighten the locking lever, first turning it, and then folding it as shown in diagram 8.

To remove the front wheel, loosen the locking lever and detach the wheel from the fork, carrying out the above operations in the reverse order.

WARNING: Check that the wheel unit is safely locked into position.

WARNING: Always check that the lever is locked correctly.

HOW TO FIT/REMOVE THE REAR WHEELS

The rear wheels have internal braking crowns, as shown in diagram 9.

10. Insert the joint of the wheel into the correct slot, until a "clak" is heard, signalling that it is locked into position; repeat the operation with the other rear wheel.

11. To remove the wheels, raise the release buttons shown in diagram 11, and remove the first wheel. Repeat the operation with the other rear wheel.

WARNING: Check that the wheel units are fitted correctly.

The wheels may be removed to make the stroller more compact when closed.

HOW TO FIT/REMOVE THE COVER

12. Insert the small round plastic devices, located at the sides of the cover, into the slots inside the tubes (diagram 12); ensure that they are completely fitted to the end of the slots (diagram 12 A).

13 **Warning:** The crotch strap is fixed to the seat support of the frame (as shown in diag. 13 A). To use the crotch

strap correctly, slide it through the hole of the cover, as shown in diagram 13 B. To use the safety harness correctly, please refer to the paragraph "How to Use the safety harness".

14. Fasten the 2 press studs (diagram 14).

15. Fit the two cover flaps of the armrests, inserting the plastic joints of the cover into the holes located on the armrests (diagram 15).

16. Before fixing the seat to the frame, check that the backrest's adjustment belt (Diag. 16-component A) is inserted correctly into the holes B. If it is not inserted as shown in diag. 16, insert belt A inside the two holes B. Then fix the 5 male, plastic spring catches, located on the fabric cover, to the 5 female, plastic spring catches located on the frame, as shown in diagram 16.

WARNING: Check that the cover is fitted correctly to the frame of the stroller.

HOW TO USE THE SAFETY HARNESS

This stroller has a 5-point safety harness featuring two shoulder straps, a lap belt and a crotch strap with dual safety buckle.

The safety harness has dual safety buttons to prevent the accidental opening of the buckle by the child.

17. After seating your child in the stroller, insert the two clips into the buckle and adjust the shoulder straps as required, passing them through the holes at the most suitable height. Adjust the height of the shoulder straps and lap belt using the buckles.

18. To unfasten the lap belt, press the red central buttons with one hand and, at the same time, press the two lateral pins.

WARNING: To guarantee the safety of your child, always use the safety harness.

HOW TO ADJUST THE BACKREST

The backrest can be adjusted through a belt adjustment system.

19. To lower the backrest, it is necessary to operate the rear adjustment system. Press the two side buttons as shown in diag. 19, adjusting the backrest until the desired position has been reached.

Vice versa, to raise the backrest, it is necessary to press the two side buttons of the adjustment system, and pull the strap until the desired position has been reached.

WARNING: The child's weight can make these operations difficult.

REMOVABLE BUMPER BAR

20. To remove the bumper bar, press the two small buttons located in the inner side of the armrests (diag. 20), and pull the bumper bar towards your direction.

HEIGHT ADJUSTABLE HANDLE

To make the stroller more ergonomic and compact, it is possible to adjust the height of the handle.

21. To raise or lower the handle of the stroller, operate the external buttons, and adjust the handle to the position that you find most comfortable (diag. 21).

SAFETY BRAKE

The safety brake locks both the rear wheels of the stroller

at the same time.

22. To operate the brakes of the stroller, push the lever located between the rear wheels in a downward direction, as shown in the diagram. To release the brake, pull the lever located between the rear wheels in an upward direction.

WARNING: Always apply the brakes whenever the stroller is stationary. **WARNING:** Never leave the stroller on a sloped surface, with a child on board, even with the brakes applied.

SLOWING DOWN BRAKE

WARNING: The intended use of the slowing down brake is to slow down the speed of the stroller. Never use the slowing down brake as a safety brake.

23. To slow down the stroller's speed, use the brake lever located on the handle (diag. 23 A). It is recommended to adjust the brakes regularly by turning nut A (as shown in diagram 23 B), which adjusts both brake shoes; If the two brakes are not aligned, it is possible to adjust them independently operating nuts B. In both cases, the brakes operate more efficiently if the nuts are screwed in an anti-clockwise direction.

FRONT SWIVEL WHEEL

The stroller has a fixed/swivel front wheel.

It is recommended to use the fix wheel when using the stroller on particularly uneven surfaces. The use of the swivel wheel is recommended to increase the manoeuvrability of the stroller.

24. To use the front wheel in the swivel mode, push the front lever in a downward direction with your foot, as shown in diagram 24. To use the front wheel in the fixed mode, lift the lever with the foot: the wheel will lock in the straight position independently of its position.

ADJUSTABLE REAR SUSPENSION

The stroller has an adjustable rear suspension.

25. To adjust the suspension, operate the lever indicated in diag. 25. By moving the lever inward, the suspension becomes softer (ideal for use with young children), while by moving the lever externally, the suspension becomes harder (ideal for older children).

Both suspension must be adjusted in the same way.

HOW TO USE THE CAR SEAT AND CARRYCOT

WARNING: Please read carefully the instruction booklets on how to use the carrycot and car seat.

WARNING: Only the CHICCO car seats and carrycots featuring the CLIK CLAK devices can be fitted to the stroller. Before using the stroller with the carrycot or car seat fitted to it, always check that the locking system is correctly and safely locked.

The stroller has the Clik Clak system, which allows you to fit the carrycot or car seat without using any further locking devices.

The stroller can be fitted with the carrycot or the car seat, both with or without stroller cover. To fit and remove the cover of the stroller, please refer to the paragraph "How to fit/remove the cover".

26. The Clik Clak locking system is located on the armrests of the stroller. First unfasten the fabric cover of the

armrests as shown in the diagram. It is recommended to raise the central part of the flap and then release the plastic joints from the slots located on the armrests. Remove the bumper bar.

27. Operate the rear buttons on the armrests (diagram 27 A), and adjust them to the highest position (diagram 27 B).

WARNING: Before fitting the carrycot or the car seat, check that the armrests are locked in the highest position. To fix the carrycot or car seat to the frame of the stroller, please refer to the instructions supplied.

28. Remove the carrycot or the car seat as indicated in the instructions, and readjust the armrests to the lowest position, operating the rear button located on the armrests. Then push the armrests in a downward direction, until they are safely locked into position (diag. 28).

WARNING: When using the transport system as a stroller, before seating the child on the cover of the stroller, ensure that the armrests are adjusted to the low position, with the fabric part fixed to the armrests.

The stroller may be closed with the armrests in the highest position; this will make the fitting of the carrycot and car seat easier when the stroller is reopened.

ACCESSORIES:

WARNING: The accessories described below may not be available for some of the models purchased. Please read carefully the instructions on the accessories available for the model purchased.

SUMMER/WINTER HOOD

29. The stroller has two slots located on the sides which allow you to fit accessories like the sun canopy and the hood. To fit the canopy, insert the locking system of the hood into the slots of the stroller's frame, as shown in diagram 29. To remove the hood, it is sufficient to slide the locking devices in the opposite direction.

30. To open the hood, push the small front arch in a forward direction, and lock it by operating the two small side arches, as shown in diagram 30.

31. The hood may feature a zip, which allows you to detach the rear panel and use the hood as a summer canopy, as shown in diag. 31.

WARNING: Some stroller models may have a simpler hood that does not feature the removable rear panel.

WARNING: The hood must be fixed on both sides of the stroller. Check that the hood is safely fitted to the stroller.

WARNING: Some hood models have a side pocket that allows you to store some small object (e.g.: keys, glasses, etc).

WARNING: Do not overload the pocket, since it has been designed to store only small objects.

PILLOWS/INSERTS

The stroller can be fitted with two pillows/inserts, one for the seat and one for the head. They can be used on either side. On one side, they have a soft and warm fleece cover that is ideal for the winter, while on the other side they have a special netting cover that ensures maximum aeration in the summer (diag. 32).

The pillows have been designed and realized to ensure

maximum comfort in each phase of baby's growth and in every season.

33. Check that the shoulder straps are adjusted to the correct shoulder height of your child; if necessary, slide

EN 1888: 2003 NF S 54-001



www.chicco.com



COMO - ITALY

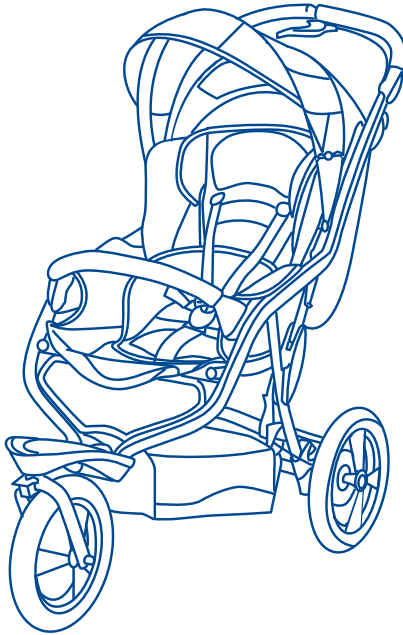

S3 All-Terrain Stroller

USA Owner's Manual Supplement

EVA Tires

KeyFit Infant Car Seat Attachment

Easy Fold

For more information, please refer to the main instruction manual.

www.chiccousa.com

⚠ WARNING: This S3 stroller can be used with children from 6 months and up to 40 lbs. To carry infants 0-6 months you **MUST** use a Chicco KeyFit or KeyFit 30 infant car seat properly attached to the stroller (see KeyFit attachment instructions).

⚠ WARNING: Do not attempt to attach any infant car seat other than the Chicco KeyFit or KeyFit 30. Injury or death may result when attempting to use this stroller in conjunction with infant car seats from other manufacturers.

Before using the stroller with the car seat fitted to it, always check that the KeyFit car seat attachment strap is positioned correctly and tightly fastened. The stroller can be fitted with the car seat, both with or without stroller soft goods. To fit and remove the soft goods from the stroller, please refer to the main manual "How to fit/remove the cover".

⚠ WARNING: Never leave child unattended in the stroller.

⚠ WARNING: Avoid serious injury from falling or sliding out. Always use seat belt.

Do not overload storage basket. Maximum weight 6 lbs.

Do not overload backpack while hanging on stroller. Maximum weight 1 lb.

Excessive weight will cause a hazardous unstable condition. Maximum weight for stroller occupant is 40 lbs.

Do not add to the stroller any items or accessories not included as it may become unstable.

KeyFit® Attachment

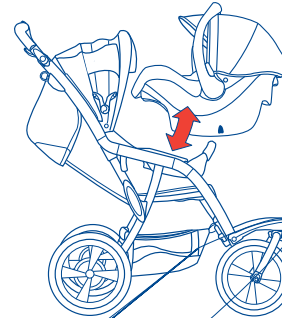

To attach the car seat to the stroller, make sure seatback is fully-reclined (see section 19 in the main manual).

2. Place car seat in stroller.

To remove the car seat from the stroller, unfasten the KeyFit car seat attachment strap and pull up on the car seat.

EVA Tires

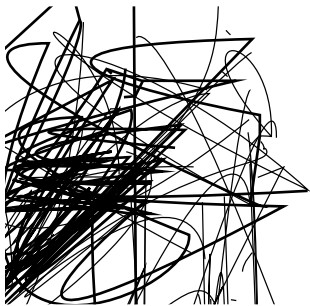

Easy Fold

⚠ WARNING: When folding the stroller, ensure that your child and other children are at a safe distance. Ensure that during these operations, the movable parts of the stroller do not come into contact with your child.

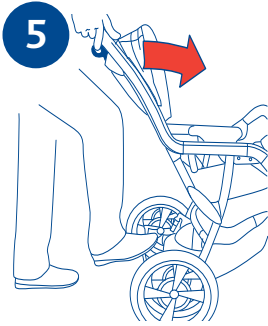

Before folding the stroller, ensure that:

- The canopy is collapsed.
- The basket is empty.
- The car seat is not fitted to the stroller.

5. Hold the stroller as shown.

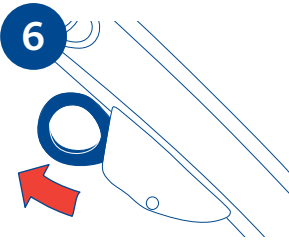

6. Pull both orange trigger open mechanisms towards you. Push the brake lever with your foot and, at the same time, push the handle in a forward direction. The stroller will begin to fold.

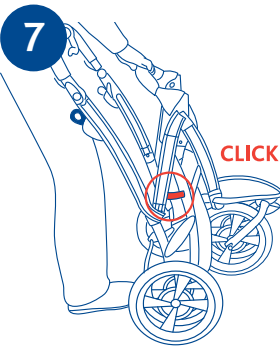

7. Fold the stroller completely, until the side locking system locks the stroller in the closed position.

To make the stroller more compact, raise the handle to the highest position. When the stroller is folded, it can be transported by holding it by the handle. When folded, the stroller will stand upright on its own.

See the main manual for instructions on unfolding the stroller.



For More Information:

By phone (toll free): (877)-424-4226

By e-mail: info@chiccousa.com

By mail: Chicco USA, Inc., 1835 Freedom Road, Lancaster, PA 17601

www.chiccousa.com