



"Serving Those Who Serve The Very Best"

INCREDIBLE FRYING MACHINE™ GAS FRYER

Service Manual



KEEP THIS MANUAL FOR TRAINING NEW PERSONNEL

1-800-KEATING
www.keatingofchicago.com

TABLE OF CONTENTS

SECTION I INTRODUCTION

General	1
Standard Features	1
Standard Accessories	1
Options	1
Ratings	1
Model Variations	1
Safety Precautions	1-2

SECTION II INSTALLATION

Damage During Shipment	3
Installation	3
Leveling	3
Restraining Devices	3
Gas Connection	4
Electrical Connection	4
Gas Leak Testing	4-5

SECTION III OPERATING THE FRYER

Filling	5
Lighting	5
Cooking	6
Shutdown	6
Draining	6
Cleaning and Boil-Out	6-7
Electronic Timers	7-8

SECTION IV MAINTENANCE

Warranty Repairs	8
Preventive Maintenance	8
Oil Breakdown	8
Thermostat Calibration	9
Thermostat Bulb Positioning	9-10

SECTION V SERVICE DIAGNOSIS

Removal/Replacement of Grease Filter	10
Flame Adjustment	10

SECTION VI SERVICE

Trouble Shooting Charts	11-12
-------------------------	-------

SECTION VII PARTS LIST

Ordering Parts	13
Warning and Operating Plates	13
IFM Gas Fryer Parts List	13
IFM Gas Fryer Assembly I	14
IFM Gas Fryer Assembly II	15
IFM Control Panel Parts List	16
IFM Burner Assembly Parts List	17
IFM Blower/Spark Module Cabinet Parts List	18

SECTION VIII WIRING DIAGRAMS

14IFM Wiring and Ladder Diagrams	19-20
Warranty	

POST THIS LABEL IN A PROMINENT LOCATION ON YOUR UNIT

IMPORTANT

IN THE EVENT A GAS ODOR IS
DETECTED, SHUT DOWN UNITS AT
MAIN SHUT OFF VALVE AND CONTACT
THE LOCAL GAS COMPANY OR GAS
SUPPLIER FOR SERVICE.



FOR YOUR SAFETY

DO NOT STORE OR USE GASOLINE OR OTHER FLAMMABLE
VAPORS OR LIQUIDS IN THE VICINITY OF THIS OR ANY OTHER
APPLIANCE.



WARNING

IMPROPER INSTALLATION, ADJUSTMENT, ALTERATION, SERVICE OR
MAINTENANCE CAN CAUSE PROPERTY DAMAGE, INJURY OR DEATH. READ
THE INSTALLATION, OPERATING AND MAINTENANCE INSTRUCTIONS
THOROUGHLY BEFORE INSTALLING OR SERVICING THIS EQUIPMENT.



*As continuous product improvement occurs, specifications may be changed without notice.

I INTRODUCTION

GENERAL

Keating Incredible Frying Machine Gas Fryers (IFM) are designed to give maximum production efficiency, delivering high quality food products. The following design features are incorporated in Keating Incredible Frying Machine Gas Fryers (IFM).

STANDARD FEATURES

- Highly polished stainless steel fryer vessel
- Highly polished stainless steel front
- Highly polished stainless steel heat transfer tubes
- Highly polished stainless steel thermostat bulb
- Highly polished stainless steel Hi-Limit bulb
- Complete stainless steel cabinet
- True Cold Zone for proper sedimentation
- Grid screen over heat transfer tubes
- 1" full port front drain valve
- Patented accurate temperature control system $\pm 2^{\circ}\text{F}$
- Ideal 35" working height
- 3/4" NPT gas connection on single fryers
- One pair of split baskets or one full-size basket
- Patented burner design
- Spark Ignition system
- 100% proof of air flow safety shut-off
- 100% proof of flame safety shut off
- Electronic timers (2)
- Gas and air adjustments
- Gas pressure test port
- Blower grease filter (easily accessible from front)
- Easy access for servicing from front of fryer
- Burner, blower and Hi-Limit indicating lights
- Insulated fryer vessel
- Heat recirculation for higher efficiency and lower flue temperature
- Black heat tube interiors for optimum heat transfer
- Instant-On™ ignition system
- 120 VAC 9' neoprene cord with 3-pronged grounded plug
- Instant recovery to cooking temperature
- High temperature stainless steel flue lining
- 100% factory testing

STANDARD ACCESSORIES

- Keating Klenzer Sample
- Keating Sea Powder Sample
- Drain clean out rod

OPTIONS

- Natural Gas or Propane
- Automatic Basket-Lift
- Cooking Computer

RATINGS

- 14" fryer vessel - 38 lb. oil capacity
- 18" fryer vessel - 68 lb. oil capacity
- 20" fryer vessel - 100 lb. oil capacity
- 3" WC (natural gas) or 10" WC (Propane) manifold gas pressure.
- 3/4" gas supply pipe recommended

MODEL VARIATIONS

Basket-Lift Model: Basket-Lift Model Fryers come with all the same features as the standard models. The Basket-Lift mechanism lowers the baskets of food into the oil when the timer button is pressed and raises the baskets when the cooking cycle is complete. Split baskets are required for these models.

CPU Model: CPU Incredible Frying Machine Gas Fryers (IFM) have the same input as the standard models. A programmable computer replaces the two timers and thermostat.

SAFETY PRECAUTIONS



THIS SYMBOL WARNS YOU THAT SERIOUS BURNS OR OTHER INJURIES MAY RESULT IF SAFETY INSTRUCTIONS ARE NOT FOLLOWED.

- This service manual should be retained in a safe place for future reference. The installation of your new fryer must conform to local codes or in the absence of local codes, with the current National Fuel Gas Code ANSI Z223.1/NFPA 54 (latest edition), Natural Gas Installation Code CAN/CGA-B149.1 or Propane Installation Code CAN/CGA-B149.2.

- Your ventilation hood, when installed, must conform to the current ANSI/NFPA 96 standard (latest edition).
- No frame or restriction shall be constructed around the fryer that will restrict air movement into the fryer's combustion area (through the grease filter underneath the fryer) or prevent proper ventilation.
- Keating fryers are designed to operate on the gas fuel specified on the serial plate and must not be operated with another gas fuel. They cannot be converted to another gas fuel by turning or engaging a switch.

FOR YOUR SAFETY: Do not store or use gasoline or other flammable vapors and liquids in the vicinity of this or any appliance.

You will post, in a prominent location, instructions to be followed in the event the user smells gas. This information shall be obtained from your local gas supplier. You may use the yellow stick-on label temporarily until you receive the data from your local gas supplier.

IMPORTANT: In the event a gas odor is detected, shut down unit at main shut-off valve and contact the local gas company or gas supplier for emergency service.

- Suitable for installation on combustible floors.
- You must maintain this appliance free and clear from combustibles.
- You must maintain the following minimum clearances from combustible and noncombustible construction:

	<u>Clearances</u>	
	<u>Combustible Construction</u>	<u>Noncombustible Construction</u>
Back	6"	0"
Right Side	6"	0"
Left Side	6"	0"

- You must install this appliance at least 16 inches away from any open flame.
- Adequate clearance for servicing and proper operation must be maintained. Your fryer is designed to be serviced from the front.
- Keating commercial fryers are intended for other than household use.
- ALWAYS instruct new employees on proper fryer operation.
- A fryer should be operated ONLY by properly trained personnel.
- ALWAYS turn fryer off each night.

- ALWAYS disconnect fuel source before servicing.
- NEVER leave a fryer unattended during operation.
- NEVER move a fryer when full of hot oil.
- NEVER introduce objects or liquids into fryer, while operational, which are not designed or made for cooking.
- THIS FRYER MAY NOT BE ALTERED, MODIFIED OR CHANGED IN ANY WAY.

The State of California enacted the California Safe drinking water and Toxic Enforcement Act of 1986, (Prop. 65), which "prohibits any person in the course of doing business from knowingly and intentionally exposing any individual to a chemical known to the State of California to cause cancer or reproductive toxicity without first giving clear and reasonable warning to such individuals." The Governor's Scientific Advisory Panel added carbon monoxide to the list of hazardous chemicals known to cause reproductive harm.

In order to establish full compliance with Proposition 65, we attached a yellow warning label to each gas fired appliance manufactured by Keating of Chicago, Inc.

Carbon monoxide would not be present in concentrations that would pose a "significant risk" to the consumer when the equipment is installed, operated and maintained as follows:

- Installed in accordance with all local codes, or in the absence of local codes, with the current National Fuel Gas Code ANSI Z223.1/NFPA 54 (latest edition).
- Installed under a properly designed operating exhaust hood.
- Connected to the type of gas for which the appliance is manufactured.
- In-line pressure regulator, not supplied by Keating, must be installed outside the appliance.
- The appliance is adjusted for the manifold pressure marked on the serial plate.
- Adequate air supply to the appliance.
- The equipment is operated in the manner intended using the proper utensils.
- Keep the equipment clean and have it checked periodically.
- Burner air adjustments, mechanical maintenance and repairs must be performed by qualified service personnel.

If the equipment is not installed, operated and maintained in accordance with the above, concentrations of carbon monoxide in excess of the established limits could be present in the kitchen environment.

II INSTALLATION

This fryer **MUST** be installed, inspected, calibrated and serviced by qualified and/or certified and/or licensed service personnel – you may void your Keating warranty if installation is not completed per local, national and Keating specifications. Contact your dealer for assistance.

DAMAGE DURING SHIPMENT

The fryer has been assembled, tested and inspected at the factory. Upon arrival, the complete fryer should be checked for any damage that may have occurred during shipment.

The carrier is responsible for all damage in transit whether visible or concealed. Do not pay for the freight bill until the fryer has been thoroughly checked for damage. If concealed damage is found later, contact the carrier immediately to file a claim.

What to do if equipment arrives damaged:

VISIBLE LOSS OR DAMAGE—Be certain to note this on the freight or express receipt and have it signed by the delivery person.

FILE CLAIM FOR DAMAGES IMMEDIATELY – Regardless of extent of damage.

CONCEALED LOSS OR DAMAGE—If damage is noticed when equipment is unpacked, notify the freight company immediately, and file a “concealed damage claim”. This **MUST** be done immediately. Be sure to retain the shipping container for inspection.

Keating does not assume responsibility for Loss OR Damage incurred in transit.

INSTALLATION

Installation must conform with local codes or, in absence of local codes, with the current National Fuel Gas Code Z223.1/NFPA 54 (latest edition), Natural Gas Installation CAN/CGA - B149.1 or Propane Installation Code CAN/CGA-B149.2. When pressure testing at test pressures less than or equal to 1/2 psig (3.45 KPA), fryer **must be isolated** from gas supply piping. When pressure testing at test pressures above 1/2 psig (3.45 KPA), fryer **must be disconnected** from gas supply piping system.

Counter model and flood model fryers must be restrained to prevent tipping when installed in order to avoid splashing, spilling, etc. of hot liquid. The restraining method may be a manner of installation or by separate means.

LEVELING

The fryer will operate at its highest efficiency when properly leveled. Place a level on fryer vessel from side to side. For fryers on legs, the bottom foot of the leg is adjustable. Turn counter clockwise to decrease height or clockwise to increase height until level. For fryers on casters, the casters are adjustable by loosening the jam nut and turning the caster in or out. When the desired level is reached, tighten the jam nut. Adjustments of more than 3/4" are not recommended on any caster. The same procedure should be followed to level the fryer from front to back.

Fig

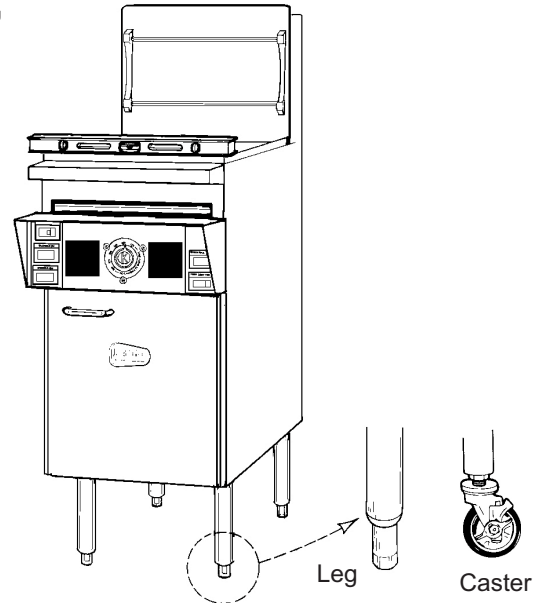

RESTRAINING DEVICES

On fryer installations with casters, casters and jam nuts must be completely tightened. Adequate means must also be provided to limit the movement of the appliance without depending on the connector, the quick-disconnect device or its associated piping to limit the appliance movement.

Connectors must comply with the current ANSI Z21.69/CAN 1 CAN/CGA 6.16 (latest edition) standard for connectors for movable gas appliances. Quick-disconnect devices must comply with the current ANSI Z21.41/CAN 1 6.9 standard for quick-disconnect devices for use with gas fuel as applicable.

The restraint must be attached to the rear of the fryer within 1" of the center line width and approximately 1" from the bottom of the cabinet back to allow the restraining bolt to be anchored through the leg channel to ensure positive support to restrain fryer movement and not depend on the connector, quick disconnect or piping to limit the fryer movement.



WARNING

IF DISCONNECTION OF THE RESTRAINT IS NECESSARY, IT MUST BE RECONNECTED WHEN THE FRYER IS RETURNED TO ITS ORIGINALLY INSTALLED POSITION.

GAS CONNECTION



WARNING

■ PIPE JOINT COMPOUNDS RESISTANT TO PROPANE GASES MUST BE USED.

■ BEFORE OPERATING THIS FRYER, CHECK PIPE JOINTS FOR LEAKS BY USING A SOAP AND WATER SOLUTION ONLY. DO NOT USE AN OPEN FLAME!

Figure 2-3

Main Gas Connection

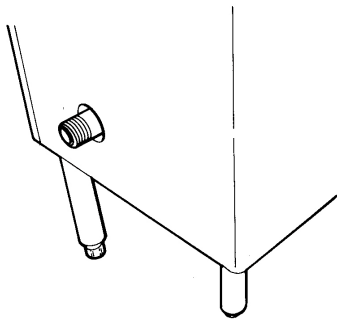

FOR YOUR SAFETY: Do not store or use gasoline or other flammable vapors and liquids in the vicinity of this or any other appliance.

Connect the fryer to the main gas supply line at the rear of the fryer. The piping should be a minimum of 3/4" NPT supply pipe for a single fryer at the burner manifold. Batteries require larger supply lines. Installation must conform to the current local codes and National Fuel Gas Code (U.S.) ANSI Z223. 1/NFPA 54 (latest edition), Natural Gas Installation Code CAN/CGA-B149.1 or Propane Installation Code CAN/CGA-B149.2 (latest edition).

NOTE: If more than one gas fryer is on the same supply line, you may require a larger line. Consult your local gas company to assure adequate volume and pressure. Refer to serial plate for proper gas requirements for your particular model.

NOTE: Piping for a battery should be at least 1-1/4" to 1-1/2" IPS, depending on total BTU input. Consult your local gas supplier for appropriate battery piping size.

ELECTRICAL CONNECTION

The Keating Incredible Frying Machine (IFM) is equipped with a 9' neoprene covered, 3 wire electrical cord with a three-pronged grounded plug for protection against electrical shock. This plug must be placed into a 120V properly grounded three-pronged polarized outlet. For proper grounding procedures see local codes, or in the absence of local codes, the National Electrical Code ANSI/NFPA 70 (latest edition) or Canadian Electrical Code CAN 22.2 (latest edition) as applicable.

CAUTION: Before plugging in the fryer, confirm the outlet is properly polarized and grounded. If the hot and neutral terminals are reversed or the outlet is not properly grounded, the burners may not ignite (burner on light will go out after 2-1/2 seconds).

NOTE: The electrical wiring diagram for the fryer is located on the inside of the fryer door.



WARNING

DO NOT CUT OR REMOVE THE GROUNDING PRONG FROM THIS PLUG.

GAS LEAK TESTING

Prior to lighting your fryer:

1. Make sure all thermostats, switches and safety valves are in the "OFF" position.
2. Turn main On/Off manual gas valve to the "ON" position.
3. Have your plumber or gas company check for leaks with a soap solution. (NEVER check with an open flame!)

Figure 2-4

IFM Control Panel

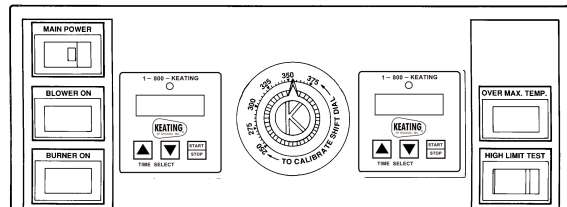

NOTE: It is estimated that half of all service calls made on Keating Incredible Frying Machine Gas Fryers (IFM) result from an inadequate gas supply. During installation, have a gas company representative make certain that the fryer is receiving adequate gas pressure and volume.



WARNING

PROPANE GAS MAY EVENTUALLY LOSE ITS ODOR AND PRECAUTIONS SHOULD BE TAKEN TO ASSURE THAT IT IS NOT PRESENT EVEN THOUGH YOU DO NOT DETECT AN ODOR. IF THERE IS ANY DOUBT, YOU SHOULD CALL YOUR LOCAL PROPANE GAS SUPPLIER FOR ASSISTANCE.

CALIBRATION

For Calibration, refer to page 9 – Calibration.

III OPERATING

FILLING

NOTE: Before filling the fryer make certain the fryer vessel is sanitized, dry and the drain valve is completely closed. Refer to item 19 on page 15 for location of drain valve.

NOTE: We recommend that solid shortening not be used in an Incredible Frying Machine Gas Fryer (IFM) as they are not equipped with a melt cycle. If solid shortening is used, it should be melted prior to filling the fryer vessel. Damage done by melting solid shortening in the fryer vessel will void the warranty.



WARNING

BE SURE THE HEAT TRANSFER TUBES ARE COMPLETELY COVERED WITH OIL BEFORE SWITCHING THE FRYER ON. IF OIL LEVEL DROPS BELOW TOP OF HEAT TRANSFER TUBES, SEVERE DAMAGE TO FRYER AND INJURY TO OPERATOR MAY RESULT!



WARNING



WATER (IN ANY FORM) AND HOT OIL DON'T MIX!!!

CAUTION: Oil expands when heated. The “Fill Level” line has been provided to ensure optimum cooking while ensuring the safety of the operator. Do not overfill the fryer vessel.

Figure 3-1
Fill Level Line

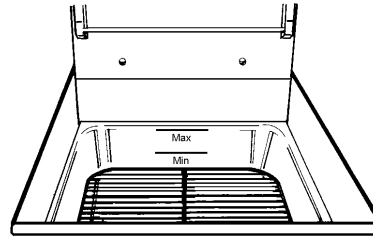

Fill the fryer vessel with oil or MELTED solid shortening up to the “Fill Level” line.

LIGHTING



WARNING

BEFORE ATTEMPTING TO LIGHT THE FRYER, MAKE SURE THE GAS CONNECTIONS ARE SECURE, HAVE BEEN LEAK TESTED, AND THE FRYER HAS BEEN PROPERLY FILLED WITH OIL.

1. Turn on main power switch.
2. Set thermostat to desired setting. (Between 325°F/162.8°C) – (335°F/165.3°C)
3. Once main power switch is on and the thermostat is set, the following occurs:
 - a. Blower will start and blower indicating light will come on.
 - b. After a preset six second delay, the gas valve will open and the burner indicating light will come on.

For your safety, the fryer is equipped with a “proof of air flow” control. If the blower fails, the gas valve will not open and the burner indicating light will not come on.

- c. The spark module will light the burners automatically.
- d. The burner indicating light will be on whenever the burners are on. The light goes off when the oil has reached the desired temperature.

NOTE: The fryer cannot be operated during a power failure as the electronic ignition system cannot be operated.

NOTE: The thermostat can be turned off by turning it fully counter clockwise until it clicks.

COOKING

Keating Incredible Frying Machine Gas Fryers (IFM) are designed to provide maximum production efficiency and deliver high quality food products. Low-temperature cooking, highly polished stainless steel and a true COLD ZONE mean extended oil life. Follow cooking procedures below for your model.

WARNING

■ **OPERATION OF THIS FRYER SHOULD BE LIMITED TO PERSONNEL WHO HAVE BEEN THOROUGHLY TRAINED IN OPERATING PROCEDURES.**

■ **USE ONLY KEATING APPROVED BASKETS IN YOUR FRYER. NEVER OVERFILL FRY BASKETS. DO NOT BANG BASKETS ON BASKET HANGERS OR ON FRYER VESSEL.**

■ **CARE SHOULD BE TAKEN WHEN LOWERING BASKETS INTO FRYER TO PREVENT SPLASHING HOT OIL FROM FRYER VESSEL.**

■ **NEVER LIFT BASKETS DIRECTLY OUT OF THE FRYER VESSEL WITHOUT DRAINING AS SEVERE INJURY MAY RESULT.**

1. Set thermostat to the desired frying temperature (between 325°F - 335°F).
2. When the oil reaches the desired temperature, burner indicating light will go off.
3. Set timer(s) to desired cooking time and fill basket(s) to proper level.
4. Lower filled basket(s) slowly into oil. For fryers with automatic basket lift, place basket(s) on upper basket hanger rods on splashback of fryer.
5. Push "Start-Stop" button of electronic timer(s). This simultaneously activates the Instant-On™ systems. For fryers with automatic basket lift, basket(s) will lower into fryer vessel.
6. When timer(s) sounds, carefully lift basket(s) out of hot oil. For fryers with automatic basket lift, a buzzer will sound and the basket(s) will rise automatically. Allow oil to drain before removing.
7. Place basket(s) on basket hanger rods on splashback of fryer and allow to drain.

SHUTDOWN

Turn off main power switch.

DRAINING

WARNING

ALWAYS SHUT THE FRYER OFF COMPLETELY BEFORE DRAINING. THE FRYER SHOULD BE DRAINED ONLY UNDER THE SUPERVISION OF PROPERLY TRAINED PERSONNEL. A DRAIN PIPE AND COVERED CONTAINER SUITABLE FOR USE WITH HOT OIL SHOULD BE USED TO ENSURE THE SAFETY OF THE OPERATOR.

1. Operator should be outfitted with proper attire including:
 - Oil and heat resistant gloves
 - Oil and heat resistant apron
 - Safety goggles
 - Oil and heat resistant footwear

Figure 3-2

Operator in safety gear

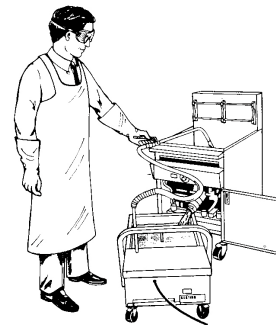

2. Turn off the fryer and open the door.
3. Put suitable container under drain valve.
4. Drain oil from fryer by slowly turning handle. The drain will be completely open after 1/4 turn.
5. After fryer drains close the drain valve.
6. Filtering may be done at this step.

Note: Fryers with central filters will be different

CLEANING AND BOIL-OUT

When cleaning and boiling out your fryer use Keating Sea Powder and Keating Klenzer to keep your fryer in top condition. Keating Sea Powder dissolves any grease build up — even carbonized grease in fryer vessels — one of the leading causes of premature oil breakdown. And once your fryer vessel is clean, use Keating Klenzer, the finest dry stainless steel polish available, to restore your Keating Incredible Frying Machine Gas Fryers' (IFM) exterior to its original luster. Both Keating Klenzer and Sea Powder are USDA approved.

Figure 3-4

Keating Klenzer and Sea Powder



1. Put on safety attire. See Draining.
2. Turn the fryer off.
3. Drain oil from fryer, see draining steps 2-4 on page 6.
4. Remove oil container to a secure area to prevent accidental spillage.
5. Fill fryer vessel to "Fill Level" line with water.



WARNING

UNDER NO CIRCUMSTANCES SHOULD THE FRYER BE LEFT UNATTENDED DURING BOIL-OUT. TRAINED PERSONNEL MUST BE PRESENT DURING THE PROCEDURE TO PREVENT BOIL OVER OR TO TURN OFF THE POWER IF WATER DROPS BELOW HEAT TRANSFER TUBES.

6. Set thermostat and turn fryer on to bring water to a gentle boil.
7. Once boil has been reached, turn fryer off.
8. Dissolve 2/3 cup of Keating Sea Powder for every five gallons of water and let soak for 1/2 hour. If there is a large build-up of carbonized grease, allow fryer to soak overnight.

CAUTION: When soaking overnight, make sure the fryer is turned off.

CAUTION: Do not damage or reposition thermostat probe as this may affect the accuracy of the fryer.

9. While soaking, a natural fiber brush may be used to scrub the tubes and inside walls of fryer.
10. Drain the water and Sea Powder into a dry suitable receptacle and remove from cooking area.
11. Spread Keating Klenzer liberally on tubes and sides of fryer vessel.
12. A non-abrasive scouring pad may be used to remove the now softened carbonized grease.
13. Thoroughly rinse fryer vessel with potable water to remove all Klenzer.

14. Prior to refilling with oil, wipe the inside of the fryer vessel making sure all water and Klenzer has been removed.



WARNING

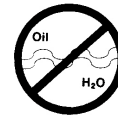

WATER (IN ANY FORM) AND HOT OIL DON'T MIX!!!

15. Close drain valve.



WARNING

FAILURE TO CLOSE DRAIN VALVE BEFORE REFILLING THE FRYER MAY RESULT IN SERIOUS INJURY.

16. Check thermostat bulb positioning – see page 9.
17. Refill the fryer with new oil.

ELECTRONIC TIMERS

STEP 1

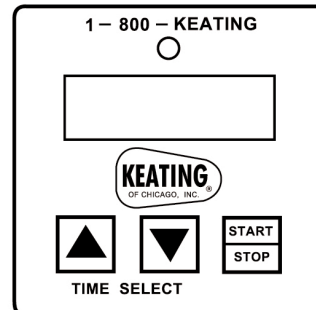

Make certain power to the timer has been OFF for at least 30 seconds. Then PRESS and hold down the UP arrow button while turning the rocker power switch to the ON position. The timer will turn ON and the display will now be indicating



The BEEPER will BEEP 4 times.

If STEP 1 was OK, proceed to STEP 2. If not, retry Step 1 making sure the power was OFF for at least 30 seconds or more.

STEP 2 PRESS all 3 buttons in sequence: left-center-right. The BEEPER will BEEP. If BEEPER does not BEEP, the timer is defective. STOP TESTING. Reset procedure is completed when 1:00 appears on the digital display (See page 8).

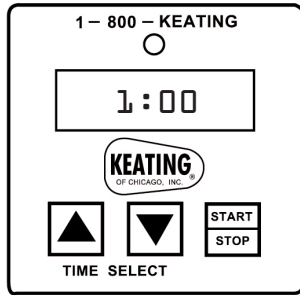

OPTIONAL TIMER OPERATING INSTRUCTIONS PART # 056921

DIGITAL TIMERS

The electronic timers, standard on TS & IFM models, provide a clearly visible and accurate display and are very easy to use.

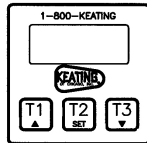

PROGRAMMING

To program the timers, the unit must be in the idle mode. Press and hold the set button for approximately two seconds. The display will show "SEt". Press the button for the channel to be programmed. The display will show the current setting for that channel. Use the up or down button to increment or decrement the setting. When the setting is correct, press and hold the set button again for approximately two seconds. The display will show "StO" for approximately two seconds and the timer will return to normal operation. Repeat the process as necessary for the other timers.

OPERATING LOGIC

When the timer is powered up, the display will show the time setting for the channel that was operated last and the relay output contacts will be open. To start a cycle, press the desired channel button (1-3). The display will begin to countdown from the preset time setting and the relay output contacts will close. During the countdown the colon will flash at a one-second rate. When the countdown has reached "00:00" the relay output contacts will open, the display will flash, and the audible alarm will sound. To cancel the audible alarm, press any button.

PAUSE FEATURE

To pause a cycle in progress, press any button. The relay output contacts will open, the display will flash, and the countdown will pause. To resume the countdown, press any button. The display will resume the normal countdown and the relay output contacts will close.

CANCELING A CYCLE

To cancel a cycle in progress press and hold any button for approximately two seconds. The relay output contacts will open and the display will show the time setting for the channel last used.

IV MAINTENANCE

WARRANTY REPAIRS

Keating's warranty begins with the date of installation (or ship date if we are not notified of an installation date). In the event that your fryer, under warranty, needs repairs other than routine maintenance or cleaning, you are required to contact Keating of Chicago (at 1-800-KEATING) before calling a local service company. Failure to do so may void your warranty.

PREVENTIVE MAINTENANCE

Preventive maintenance should be done in daily, weekly, monthly and yearly intervals as necessary. Following preventive maintenance procedures will help keep your fryer working efficiently. Proper care and servicing will lead to years of quality performance.

PREVENTIVE MAINTENANCE CHART

TIME FRAME	OPERATOR/OWNER	SECTION
Daily	<ul style="list-style-type: none"> • Check lights and controls. • Check that the oil is up to "Fill Level" Line. • Clean all baskets. • Drain, strain or filter shortening. 	III
Weekly*	<ul style="list-style-type: none"> • Drain and clean fryer. • Boil-out fryer. • Clean blower grease filter. 	III & VI
Monthly*	<ul style="list-style-type: none"> • Verify thermostat settings. • Test Hi-Limit control. 	III IV & V
Yearly*	<p>QUALIFIED SERVICE PERSONNEL ONLY</p> <ul style="list-style-type: none"> • Check burner flame color and adjust air shutters. 	V

*High production facilities should be checked more often.

A. Oil Breakdown

As part of a "Preventive Maintenance Program", the oil in your fryer needs to be filtered regularly to avoid breakdown. The initial investment in the frying system is less than the total overall costs of oil during the life of the fryer, and with regular filtering, you can realize substantial savings in oil costs, as well as maintenance charges.

B. Thermostat Calibration

You will need:

- One screwdriver with 1/8" wide flat blade
- One accurate fryer thermometer

1. Set thermostat to desired frying temperature.
2. Allow fryer to cycle three times.
3. Place an accurate thermometer in the oil at the tip of the thermostat bulb.

Figure 4-1

Thermostat calibration with knob on

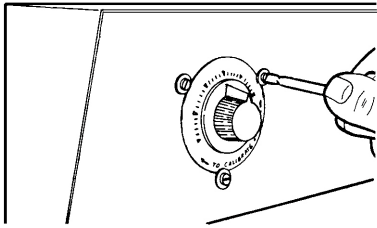

NOTE: Locate thermometer in same position for every calibration.

4. If calibration of fryer is found to be less than 25°F off, simply loosen the three retaining screws holding the dial plate in place. Reset the dial plate to match the thermometer reading. If the fryer is found to be more than 25°F off, a qualified service company must be contacted to have the fryer properly calibrated.

C. Thermostat Bulb Positioning

BEFORE REPLACING, TEST THERMOSTATS:

These operational problems can easily be corrected by thermostat bulb positioning.

Keating's patented thermostat application is accurate within 2°F of the dial setting between 250°F – 350°F. This accuracy is attained only if the thermostat bulb is placed properly against the heat transfer tube. To quickly and accurately test for proper bulb placement, a single thickness of writing paper should be pulled through between the tube and the bulb with medium resistance.*

1. *For gas fryers 14":

- The end of thermostat bulb should touch the burner tube.

2. For gas fryers 10x11, 18 & up:

- If the bulb is too loose, the paper will slip through with little or no resistance. A fryer with a thermostat bulb that is too loose will overshoot.

Overshoot: The thermostat takes a long time to

cycle and then misses its preset temperature by 20°F - 40°F yielding a poor quality product.

- If the bulb is too tight, the paper will either not pull through or it will tear. A fryer with a thermostat bulb that is too tight will short cycle.

Short Cycle: The thermostat will cycle rapidly while the fryer is in the idle mode; the temperature will be erratic.

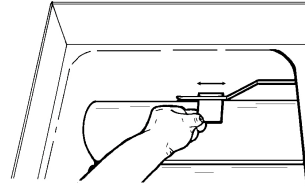

Thermostat Bulb Positioning 10x11, 18 & up Fryer Gas

REQUIRED TEST EQUIPMENT:

Multimeter (for testing continuity)

CHECKING CONTINUITY WITH THE MULTIMETER

1. Rotate the thermostat shaft until an audible click is heard.
2. Rotate the thermostat shaft left and right ten times causing the switch to click on and off ten times, while using the Multimeter to verify continuity.
3. If the switch does not show continuity during all ten trials, replace the thermostat.



WARNING

Disassembling the thermostat will void the thermostat warranty.

1. Set compression ring onto capillary end of bulb finger tight, 1/2" from end of capillary.
2. Insert new thermostat bulb through control panel back.
3. Apply oil resistant flexible sealant onto compression fitting thread before installing fitting into fryer vessel.
4. Position bent portion of bulb against far right heat transfer tube and install compression fitting snugly into fryer vessel.
5. Adjust bulb so at least 2" of bent portion of it is next to heat transfer tube and tighten compression nut onto compression fitting for fryer 10x11, 18 & up. The end of thermostat bulb should touch the burner tube for 14" fryers.
6. Refill fryer with oil to "fill level line".
7. Start fryer, preheat and calibrate with thermometer.

Figure 4-3

Thermostat Bulb Positioning

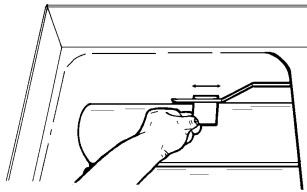

V SERVICE

REMOVAL AND REPLACEMENT OF GREASE FILTER

The grease filter cleans grease from the air entering the blower and burner assemblies, providing optimum reliability and performance of the fryer. It consists of an aluminum mesh which can be easily cleaned in a dishwasher.

Removal:

1. Loosen filter handle thumbscrew (located on front leg channel), drop handle down and slide filter forward.

Replacement:

1. Center the filter under the filter handle thumbscrew and slide it under the blower/spark module assembly until goes in all of the way. Pull handle up into place and tighten thumbscrew.



WARNING

ALL HI-LIMIT CONTROLS ARE PRESET AT THE FACTORY FOR A SPECIFIC TEMPERATURE. DO NOT ATTEMPT TO CHANGE THE SETTING OF THE HI-LIMIT. IF THE HI-LIMIT FAILS TO SHUT OFF BETWEEN 425°F AND 450°F DURING TESTING, IT SHOULD BE REPLACED.

FLAME ADJUSTMENT

A. Gas Pressure

1. At gas valve, remove adjustment port cover, (brass screw located above the black electrical terminal box), rotate adjustment screw with screwdriver and replace port cover.

AIR SHUTTER POSITION	BURNER FLAME APPEARANCE
Fully closed	Dull red with aqua colored tips
	Brighter red
	Bright red-orange with orange haze
Desired position	Bright red-orange with orange glow
Desired position	Bright red-orange with faint blue tips
	Bright red
	Duller red with faint blue tips or blue at front of burner
Fully open	Dull red with blue haze or totally blue

2. To check the gas pressure (3" WC for natural gas or 10" WC for Propane, low input units 2.4"), use an allen wrench to remove the gas pressure test port, located in the center of the 1/2" pipe T-fitting which feed the 3/8" aluminum burner gas supply tubes.

B. Air Flow

1. The air shutter is located in the front of the blower cabinet where the two air hoses enter the cabinet. It consists of two plates, each located directly above an air hose and held in place by a hex head screw. (See item #9, page 18)
2. To adjust the air mixture, loosen the shutter screw for one burner only and move the shutter up or down until the proper gas/air mixture is reached for that burner. Tighten the shutter screw and repeat the process for the other burner.
3. To determine the proper gas/air mixture, look into the viewing window for each burner, located just to the left of each burner air hose where the hose is connected to the burner assembly.
 - bright red/orange with proper mixture – orange “glow” around burner tube
 - too little air – orange “haze” around burner tube (showing incomplete combustion)
 - too much air – blue at front of burner, or totally blue
4. The burner air/gas mixture status chart shows the burner flame characteristics over the complete adjustment range of the air shutter. It can be used to more accurately determine the burner air/gas mixture to see if any adjustments are needed. Each burner should be checked independently of the other.

VI SERVICE DIAGNOSIS

A properly adjusted Keating Incredible Frying Machine Gas Fryer (IFM), with no load, will cycle “On” approximately every 2-1/2 to 3 minutes. Each cycle will last 15 to 25 seconds, ensuring that the temperature setting is held within a narrow band.

- Every Keating Incredible Frying Machine Gas Fryer (IFM) has a number of safety controls to ensure safe operation and guard against component failure.

A. Trouble shooting chart

The following diagnosis is only to be used as a guide to qualified service personnel. Keating recommends that you use a qualified service company. Call 1-800-KEATING if you need assistance in locating a qualified service company.

NOTE: To correctly and quickly diagnose the system, the chart below must be followed in sequential order.

PROBLEM	PROBABLE CAUSE	SOLUTION
Main power light does not come on.	<ul style="list-style-type: none"> a. Fryer not plugged in. b. Main power switch is faulty. 	<ul style="list-style-type: none"> a. Plug fryer into approved outlet. Must be properly grounded. b. Replace the main power switch.
Blower light does not come on.	<ul style="list-style-type: none"> a. Thermostat not turned on. b. If blower comes on, blower light is faulty. c. If Over Maximum Temperature light is on, Hi-Limit has been activated. d. If blower does not come on, blower is faulty. 	<ul style="list-style-type: none"> a. Set thermostat to desired temperature. b. Replace blower light. c. Reset Hi-Limit after oil has cooled down below 425°F. Correct problem which caused Hi-Limit to activate. (See page 9) d. Verify power to blower. Replace blower.
Burner light does not come on.	<ul style="list-style-type: none"> • Check for spark at each burner. If no spark at either burner: <ul style="list-style-type: none"> a. Purge time delay relay is faulty (if it has no output voltage.) b. Spark module is faulty. • Check for spark at each burner. If spark occurs at both burners: <ul style="list-style-type: none"> c. Burner light is faulty. 	<ul style="list-style-type: none"> a. Replace purge time delay relay. b. Replace spark module. c. Replace burner light.
Burner light comes on, then goes out (after 2-1/2 seconds.)	<ul style="list-style-type: none"> • Check for spark at each burner. If no spark at either burner: <ul style="list-style-type: none"> a. Spark electrode wires are faulty. b. Spark electrode is faulty or is out of alignment. • Check for spark at each burner. If spark occurs at both burners: <ul style="list-style-type: none"> c. Gas is not turned on. d. Combination gas valve is faulty. 	<ul style="list-style-type: none"> a. Replace spark electrode wires. b. Align spark electrode. Replace spark electrode if faulty. Gap must be 1/8" between electrode and pilot tube and between pilot tube & burner. c. Turn manual gas valve on. If using flexible connector with quick disconnect, make sure that the quick disconnect is completely engaged. d. Replace gas valve (verify voltage to the valve first).

PROBLEM	PROBABLE CAUSE	SOLUTION
Delayed ignition.	<ul style="list-style-type: none"> a. Blower screen not cleaned. b. Spark electrode gap is incorrect. c. Gas pressure excessive (incoming or manifold). 	<ul style="list-style-type: none"> a. Clean blower screen. (#13, 14, on page 14). b. Set proper gap on electrode. (See detail on page 17) c. Set pressure to serial plate.
Fryer has poor recovery.	<ul style="list-style-type: none"> a. Over-filling baskets. b. Over-filling fryer with oil. c. Thermostat bulb improperly placed. d. Carbon coating on heat transfer tubes. e. Low gas pressure or volume. f. Inefficient burner combustion. g. Electronic timer and/or Instant On™ relay(s) are faulty. 	<ul style="list-style-type: none"> a. Don't over-fill baskets. b. Fill fryer up to "Fill Level" line as oil will expand when heated. c. Adjust bulb position. See page 9 – Thermostat Bulb Positioning. d. Boil-out fryer. See pages 7 – Cleaning and Boil-out. e. Contact a qualified service person to check gas pressure. f. Adjust gas/air mixture. See page 10 – Flame Adjustment. g. Replace timer and/or relay(s).
Fryer overshoots temperature setting.	<ul style="list-style-type: none"> a. Thermostat bulb improperly placed. b. Thermostat out of calibration. 	<ul style="list-style-type: none"> a. Adjust bulb position. See page 9 – Thermostat Bulb Positioning. b. Calibrate thermostat. See page 9 – Calibration.
Oil in fryer vessel smokes.	<ul style="list-style-type: none"> a. Oil has begun to breakdown. b. High carbon content in oil. c. Dirty fryer vessel. d. Inferior grade of oil. e. Fryer is overheating. 	<ul style="list-style-type: none"> a. Replace oil. b. Filter oil completely, replace if necessary. c. Boil-out fryer. See pages 7 – Cleaning and Boil-out. d. Check with supplier for the grade of oil needed for your cooking applications. e. Check calibration of thermostat (See page 9) and replace if necessary.
Basket lift mechanism will not operate.	<ul style="list-style-type: none"> a. Connections are loose or electronic timer is faulty. b. Motor limit switch is faulty. c. Lift motor is faulty. d. Basket lift relay is faulty. e. Actuator defective. 	<ul style="list-style-type: none"> a. Make sure connections are tight. Replace timer if faulty. b. Replace limit switch or straighten arm. c. Replace motor. Specify left or right side motor when ordering. d. Replace relay. e. Replace actuator.
Basket lift motor runs, but basket does not move.	<ul style="list-style-type: none"> a. Cam is slipping on motor shaft. b. Actuator if faulty. 	<ul style="list-style-type: none"> a. Tighten cam onto motor shaft. b. Replace actuator.
Basket(s) rise prematurely.	<ul style="list-style-type: none"> a. Hi-Limit has been activated. b. Electronic timer is faulty. c. Basket lift relay is faulty. 	<ul style="list-style-type: none"> a. Reset Hi-Limit after oil has cooled down below 425°F. Correct problem which caused Hi-Limit to activate. b. Replace timer. c. Replace relay.

VII PARTS LISTS

ORDERING PARTS

Parts may be ordered by part number by calling your local service company or Keating at 1-800-KEATING.

Refer to the Keating Incredible Frying Machine™ Gas Fryer Limited Warranty for complete service and ordering information.

The model/serial plate is located on the inside of the front door. The serial and model numbers are necessary when ordering.

WARNING AND OPERATING PLATES

All warning and operating plates on the Keating Incredible Frying Machine™ Gas Fryer should be in place at all times. If plates are damaged or lost, replace them immediately.

INCREDIBLE FRYING MACHINE™ GAS FRYER PARTS LIST

ITEM	DESCRIPTION	MODELS	PART #	Qty
1	GAS VALVE, 3/4" 120V NATURAL GAS LP DUAL SOLENOID VALVE 1/2" (BASTROL)	ALL	004269 008123 020470	1 1 1
2	BLOWER/SPARK MODULE BOX	SEE PAGE 18		1
3	COMPRESSION FITTING, 3/8" TO 1/2"	ALL	015388	2
4	TUBING, BURNER GAS SUPPLY	14 IFM 18 & 20 IFM	054512 022409	2
5	FLEXIBLE TUBING, BURNER AIR SUPPLY	14 IFM 18 & 20 IFM	015908 CALL 1-800-KEATING	2
6	HOSE CLAMP	ALL	015393	4
7	SPARK ELECTRODE WIRE	ALL	037462	2
8	FLEXIBLE CONDUIT, WITH FITTINGS	14 IFM 18 & 20 IFM	CALL 1-800-KEATING CALL 1-800-KEATING	1
9	FLEXIBLE CONDUIT, WITH FITTINGS	CALL 1-800-KEATING		1
*10	WIRING HARNESS FOR ITEM 9	14 IFM 18 & 20 IFM	CALL 1-800-KEATING CALL 1-800-KEATING	1
*11	REAR DRAIN SAFETY SWITCH	W/WOSA	004592	1
13	AIR FILTER, BLOWER	14 IFM W/WOSA 18 & 20 IFM W/WOSA	016378 017019 022163 022164	1 1 1 1
14	THUMBSCREW, BLOWER AIR FILTER	ALL	026826	1
15	90° ORIFICE HOLDER	14 IFM 18 & 20 IFM	021871 (Nat) 021875 (Nat)	2
16	BURNER ASSEMBLY	SEE PAGE 17		2
17	BURNER ORIFICE (NATURAL GAS)	14 IFM 18 IFM 20 IFM	016502 021869 021869	2 2 2
18	FRYER VESSEL (INSULATED)	CALL 1-800-KEATING		1
19	DRAIN VALVE, FRONT, 1" DRAIN VALVE, REAR, 1"	14 IFM W/WOSA	016884 016341	1 1
20	DOOR CATCH, ROLLER STYLE	ALL	004540	1
21	DRIP CUP (INSIDE DOOR)	ALL	004552	1
22	HI-LIMIT CONTROL	ALL	004341	1
23	THERMOSTAT	14 IFM 18 & 20 IFM	035574 035575	1
24	BASKET HANGER MOUNTING BLOCK	W/O BASKET LIFT LEFT RIGHT	004539 004538	1 1
25	BASKET HANGER ROD	W/O BASKET LIFT	003895	2
26	GASKET, FLUE BOX	ALL	016511	1

*ITEMS NOT SHOWN ON DRAWINGS

INCREDIBLE FRYING MACHINE (IFM) GAS FRYER ASSEMBLY I

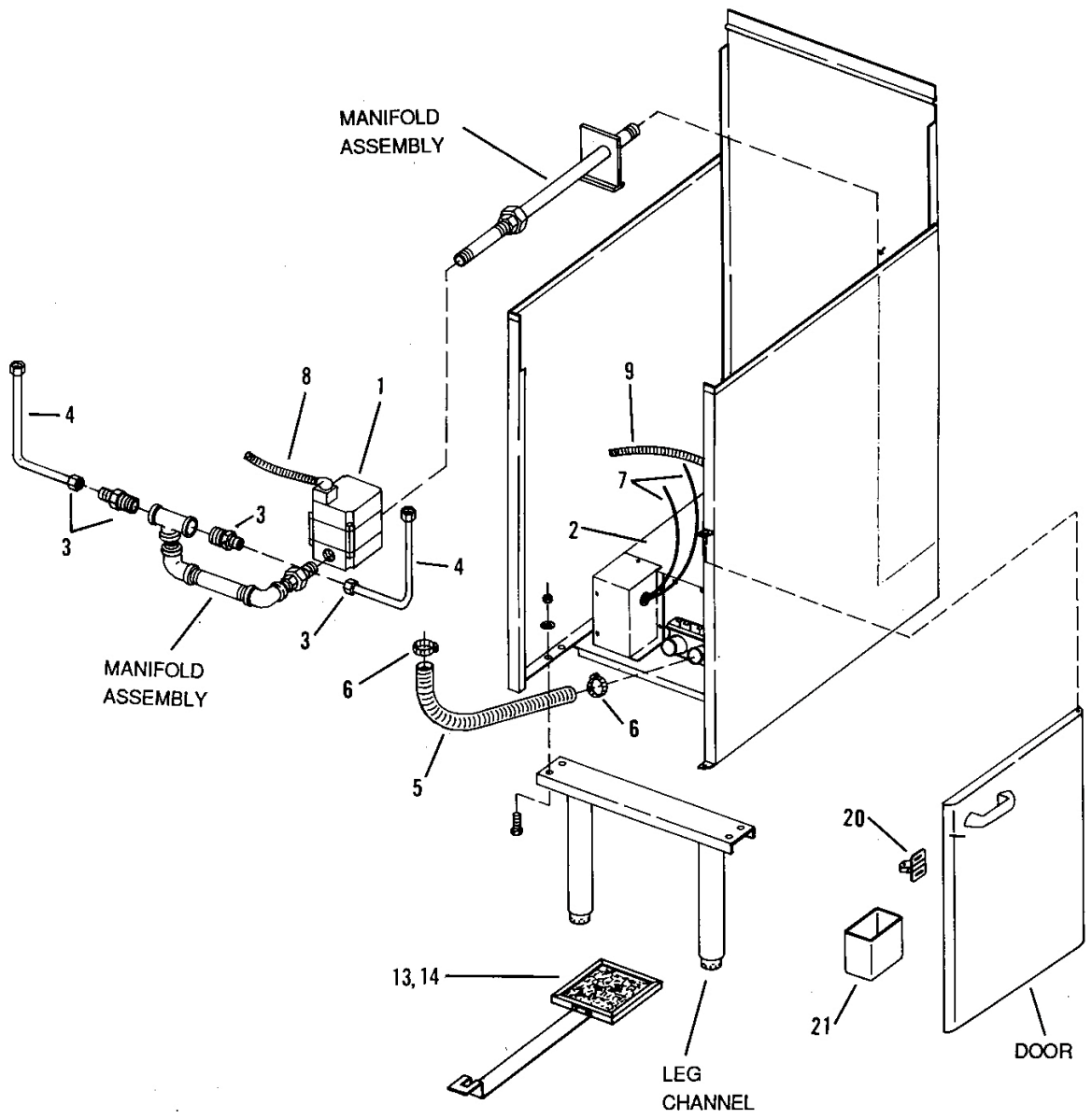

NOTE: Part numbers correspond with the Incredible Frying Machine (IFM) Gas Fryer Parts List on Page 13.

INCREDIBLE FRYING MACHINE (IFM) GAS FRYER ASSEMBLY II

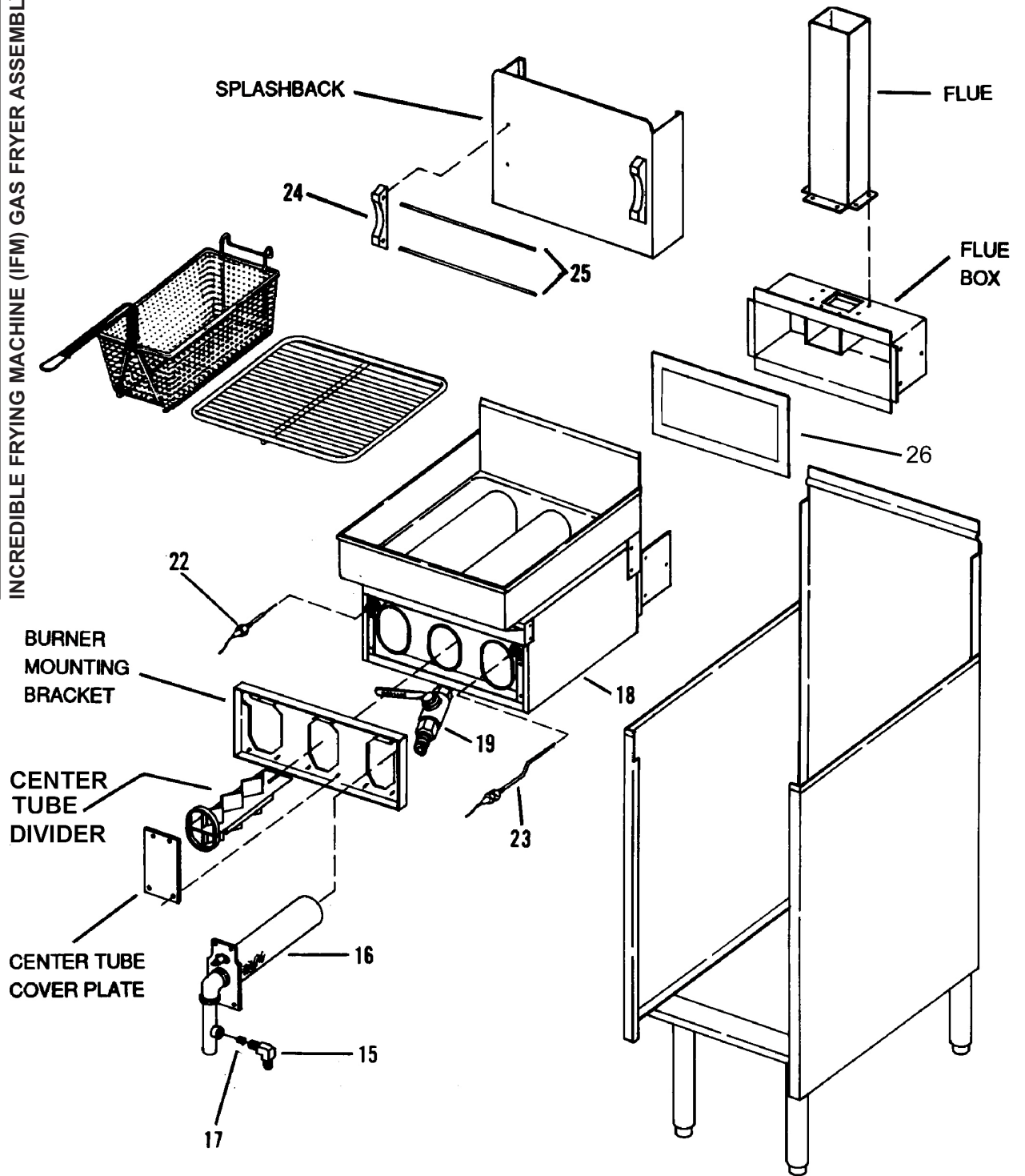

NOTE: Part numbers correspond with the Incredible Frying Machine (IFM) Gas Fryer Parts List on page 13.

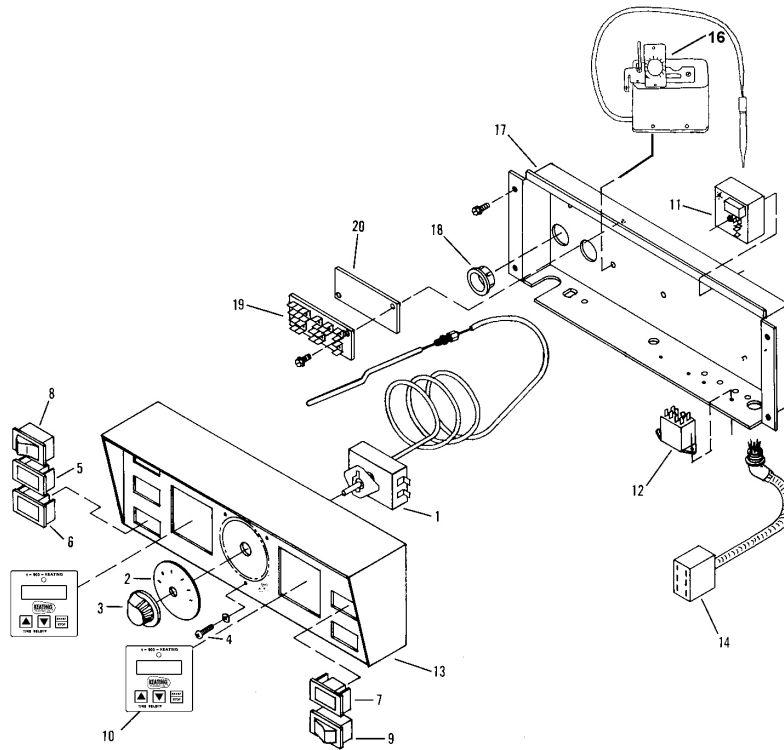

Figure 7-1 IFM Control Panel (with or without Basket Lift)

ITEM	DESCRIPTION	QTY	PART NUMBER
1	THERMOSTAT 14"	1	004166
	THERMOSTAT 18" & 20"		030833
2	THERMOSTAT DIAL PLATE	1	004164
3	THERMOSTAT KNOB	1	004163
4	RETAINING SCREWS	3	004610
5	INDICATING LIGHT, BLOWER ON (BLUE)	1	015120
6	INDICATING LIGHT, BURNER ON (RED)	1	015121
7	INDICATING LIGHT, OVER MAX. TEMP. (RED)	1	015121
8	ROCKER SWITCH, LIGHTED, MAIN ON/OFF	1	015119
9	ROCKER SWITCH, HI-LIMIT TEST	1	015384
10	KEATING TIMER	2	023709
11	TIMING RELAY, INSTANT-ON™	2	016189
12	RELAY, BASKET LIFT AND INSTANT-ON™	2	008088
13	CONTROL PANEL, HOODED	CALL 1-800-KEATING	
14	WIRE HARNESS WITH PLUG, 2", FOR BASKET LIFT - 14IFM	N/A	
16	HI-LIMIT CONTROL	1	004341
17	CONTROL PANEL BACK	CALL 1-800-KEATING	
18	BUSHING, 7/8" HEYCO	2	000514
19	TERMINAL BOARD	1	000639
20	INSULATION BOARD	1	000263
21	WIRING HARNESS, CONTROL PANEL (NOT SHOWN)		
	14IFM	N/A	
	18 & 20IFM	N/A	
22	WIRING HARNESS, CONTROL PANEL BACK (NOT SHOWN)		
	14IFM	N/A	
	18IFM	N/A	

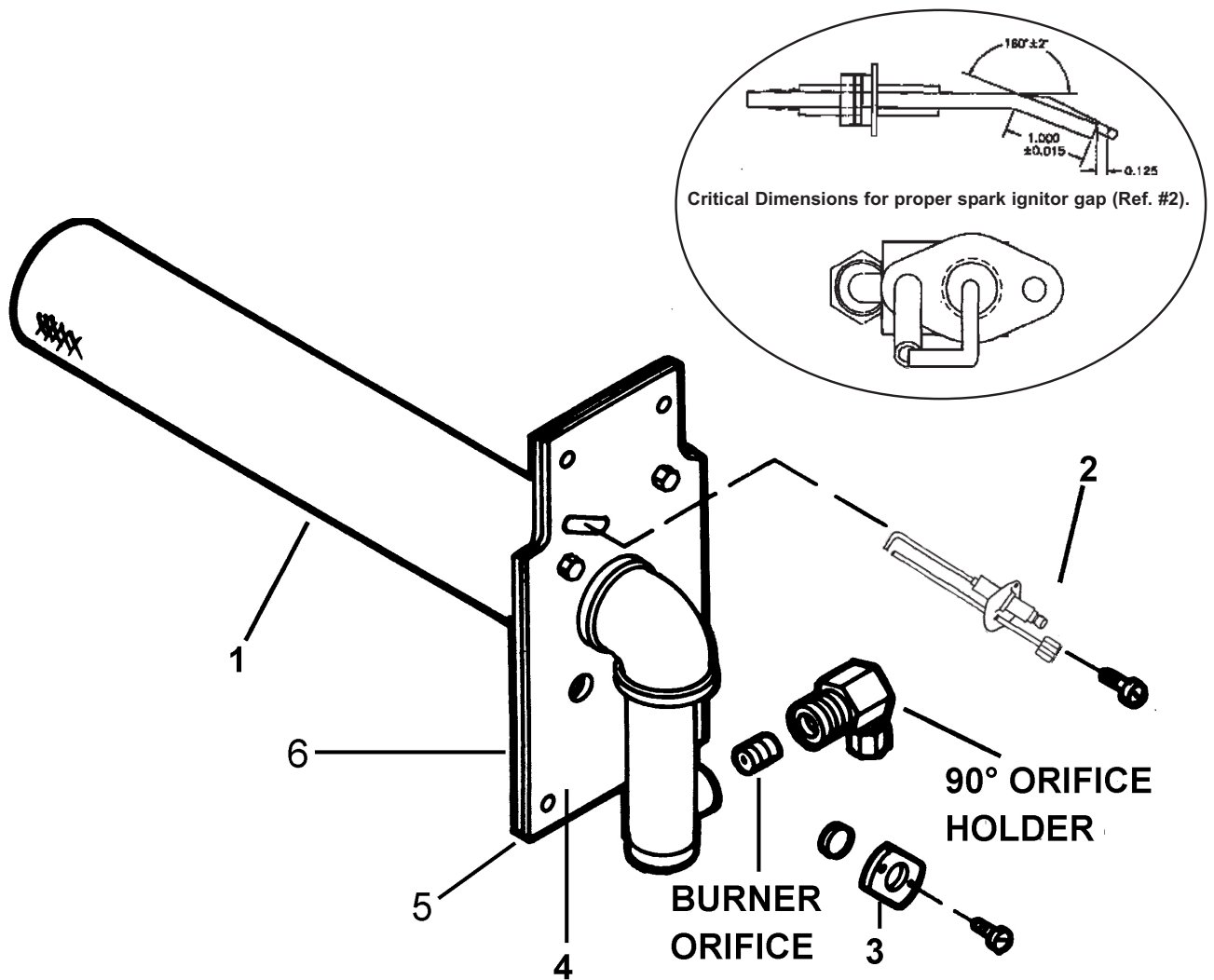

Figure 7-2 IFM Burner Assembly (Right Side Shown)

ITEM	DESCRIPTION	QTY	PART NUMBER
1	BURNER REPLACEMENT KIT (BURNER WITH ITEMS 5 & 6)	1	016506
2	SPARK ELECTRODE REPLACEMENT KIT NATURAL GAS LP GAS	1	052562 052908
3	OBSERVATION WINDOW ASSEMBLY LENS COVER	1	016101 015905
4	BURNER OUTER PLATE & ELBOW ASSEMBLY (LEFT OR RIGHT SIDE)	1	022158
5	BURNER TO PLATE SEALING GASKET	1	016505
6	BURNER TO TUBE SEALING GASKET	2	016504
7	ORIFICE HOLDER NATURAL GAS LP GAS	1	053208 053210

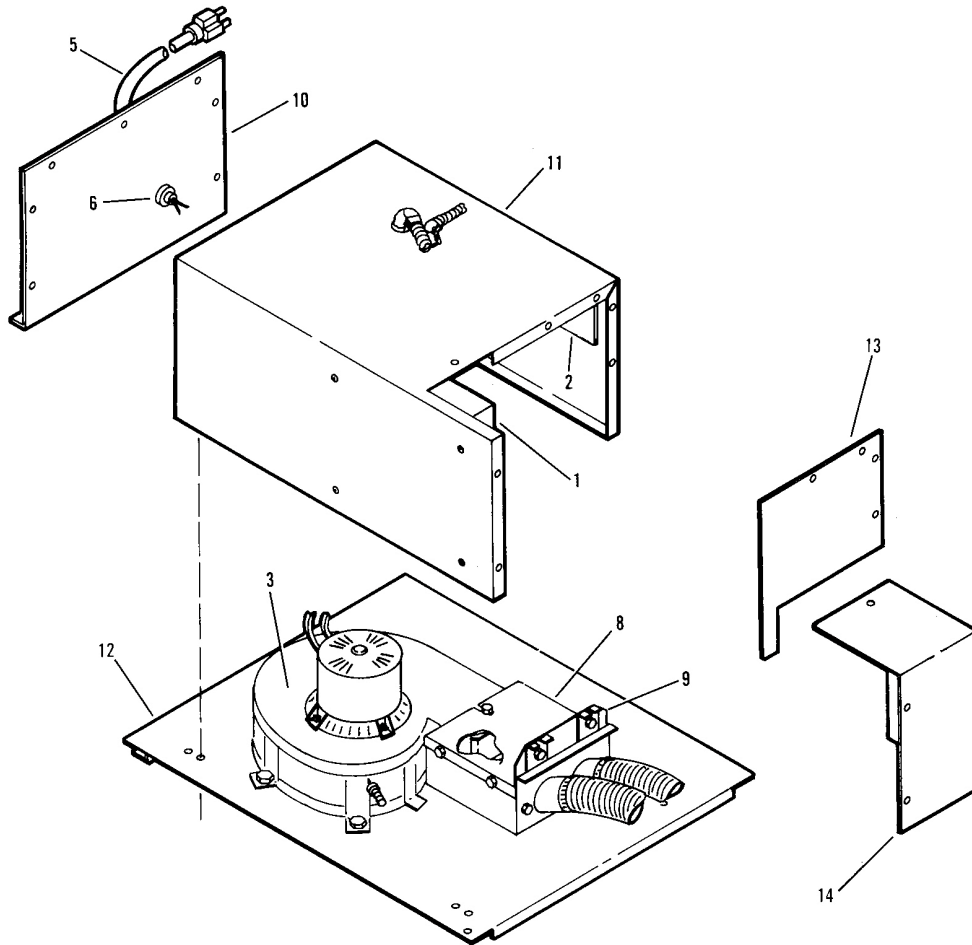
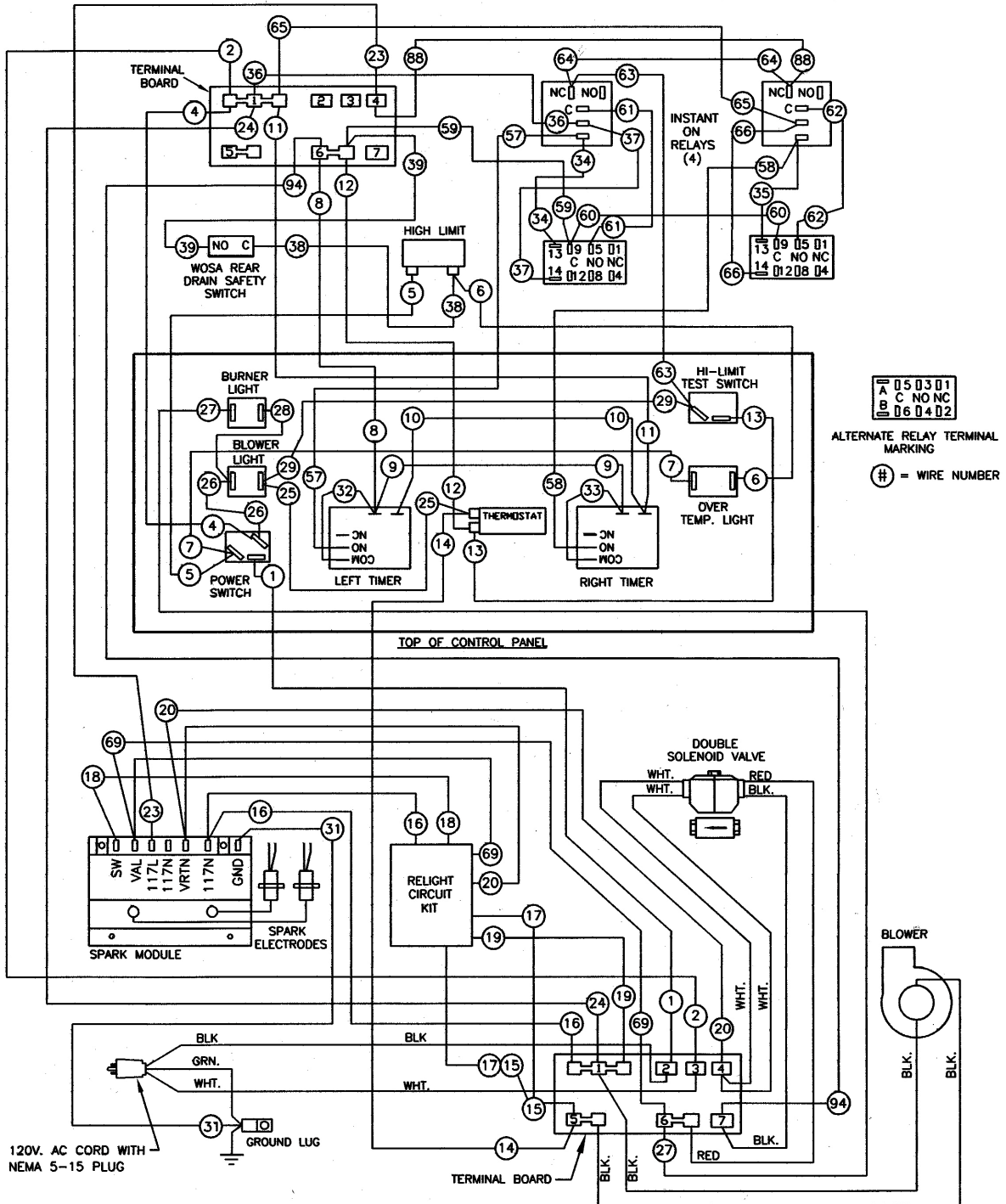

Figure 7-3 IFM Blower/Spark Module Cabinet

ITEM	DESCRIPTION	QTY	14IFM	18 & 20 IFM
1	SPARK MODULE	1	019724	019724
2	RELIGHT KIT	1	021351	021351
3	BLOWER	1	025710	020976
5	CORD WITH PLUG, 9'	1	006311	006311
6	BUSHING, STRAIN RELIEF, PLASTIC	1	000470	000470
7	WIRING HARNESS (NOT SHOWN)	1	N/A	N/A
8	AIR PLENUM	1	020816	025960
9	AIR SHUTTER			
	LEFT	1	020273	025662
	RIGHT	1	020607	025663
10	BLOWER BOX REAR COVER	1	1-800-KEATING	1-800-KEATING
11	BLOWER BOX COVER	1	1-800-KEATING	1-800-KEATING
12	BLOWER BOX BASE	1	1-800-KEATING	1-800-KEATING
13	BLOWER BOX FRONT COVER	1	1-800-KEATING	1-800-KEATING
				1-800-KEATING
14	SPARK MODULE COVER	1	1-800-KEATING	-----

VIII WIRING DIAGRAMS

14 IFM WOSA — 120V CONNECTION DIAGRAM — KEATING ELECTRONIC TIMERS



KEATING WARRANTY

LIMITED WARRANTY

Keating Of Chicago, Inc. ("Keating") warrants to the original purchaser. ("Customer"), all new Keating Fryers, Filter Systems, Griddles, Keep Krisp®, Custom Pasta Systems, Top-Side™ Cookers, Computer Timers, Fryer & Pasta Vessels, and Keating replacement parts ("products") installed after June 1, 1994 to be free to defects in material or workmanship, subject to the following terms and conditions.

LENGTH OF WARRANTY

All products other than Fryer & Pasta Vessels and replacement parts shall be warranted for a period of one year from the date of original equipment installation. Keating replacement parts are warranted for a period of ninety days from the date of installation. Fryer & Pasta Vessels are warranted as described below.

FRYER & PASTA VESSEL WARRANTY

Fryers purchased after June 1, 1994 carry a prorated vessel warranty on defects in materials or workmanship to the Customer based on the following scale:

Fryer Vessel Warranty Credit

<i>Time from Installation Date</i>	100%
13-60 months	80%
61-72 months	60%
73-84 months	40%
85-96 months	20%
97-108 months	10%
109-120 months	0%

The credit for the defective fryer & pasta vessel shall be applied against the cost of the replacement vessel, utilizing Keating's then current price, upon return of the vessel to Keating. (Freight to be paid by Keating within the first 2 months only), only during the first 60 months as described above, subject to the limitations described below.

LIMITATIONS OF LIABILITY

In the event of warranty claim or otherwise, the sole obligation of Keating shall be the repair and/or replacement at the option of Keating of the product or component or part thereof. Such repair or replacement shall be at the expense of Keating except that the Customer shall pay the following expenses: all freight and labor expense for Keating replacement parts for all other products, mileage exceeding 50 miles or travel more than one hour, labor costs of more than one person, overtime rates, truck charges, difference between ground and other mode of transportation, and holiday charges. Any repair or replacement under this Limited Warranty does not constitute an extension of the original warranty for any period for the product or for any component or part thereof. Parts to be replaced under this Limited Warranty will be repaired at the option of Keating with new or functionally operative parts. Keep Krisps and Computer Timers must be returned to Keating for warranty repair or replacement. Field repairs of those items are not authorized.

THE LIABILITY OF KEATING ON ANY CLAIM OF ANY KIND, INCLUDING CLAIMS BASED ON WARRANTY, EXPRESSED OR IMPLIED, CONTRACT, NEGLIGENCE, STRICT LIABILITY OR, ANY OTHER THEORIES SHALL BE SOLELY AND EXCLUSIVELY THE REPAIR OR REPLACEMENT OF THE PRODUCT AS STATED HEREIN, AND SUCH LIABILITY SHALL NOT INCLUDE, AND CUSTOMER SPECIFICALLY RENOUNCES ANY RIGHTS TO RECOVER, SPECIAL, INCIDENTAL, CONSEQUENTIAL OR OTHER INJURIES TO PERSONS OR DAMAGE TO PROPERTY, LOSS OF PROFITS OR ANTICIPATED PROFITS, OR LOSS OF USE OF THE PRODUCT.

If any oral statements have been made regarding the Keating products, such statements do not constitute warranties and are not part of the contract sale. This Limited Warranty constitutes the complete, final and exclusive statement with regard to warranties.

THIS LIMITED WARRANTY IS EXCLUSIVE AND IS IN LIEU OF ALL OTHER WARRANTIES WHETHER WRITTEN, ORAL, STATUTORY OR IMPLIED, INCLUDING BUT NOT LIMITED TO ANY WARRANTY OF MERCHANTABILITY OR FITNESS FOR PARTICULAR PURPOSE OR WARRANTY AGAINST LATENT DEFECTS.

The warranties provided by Keating of Chicago, Inc. do not apply in the following instances:

1. Defects arising out of or resulting from improper installation or maintenance, abuse, misuse, modification or alteration by unauthorized service personnel, or any other condition not attributable to a defect in material or workmanship. Proper installation and maintenance are the responsibility of the installer and Customer, respectively. Proper installation and maintenance procedures are prescribed by the Keating Service Manual.
2. In the event that the product was damaged after leaving the factory due to flood, fire, other acts of God or accident, damage during shipment should be reported to the carrier and is not the responsibility of Keating.
3. In the event the serial number or rating plate has been removed from the product or altered.
4. On parts which would normally be worn or replaced under normal conditions, including but not limited to electric bulbs, fuses, interior and exterior finishes, gaskets and radiants.
5. With regard to adjustments and calibrations such as leveling, tightening of fasteners or plumbing connections, improper gas pressure or improper electrical supply, the checking of and changes in adjustment and calibrations are the responsibility of the installer. Proper installation procedures are prescribed by the Keating Service Manual.
6. In the event of unauthorized repairs or alterations to the Keating product.
7. With the use of sodium chloride in pasta vessels or harsh chemicals in fryer or pasta vessels.

The Customer must provide proof of purchase from Keating.

This Limited Warranty is valid in the 50 United States, its territories, and Canada, and is void elsewhere.

Keating products are sold for commercial use only. If any Keating product is sold as a component of another product or used as a consumer product, such Keating product is sold As Is without any warranty. If any provision of this Limited Warranty is held to be unenforceable under the law of any jurisdiction, such provision shall be inapplicable in such jurisdiction, and the remainder of the warranty shall remain unaffected. Further in such event, the maximum exclusion or limitation allowable under applicable law shall be deemed substituted for the unenforceable provision. This Limited Warranty shall be governed by and construed in accordance with the laws of the State of Illinois.

TO SECURE WARRANTY SERVICE

All repair services under this Limited Warranty must be authorized by Keating or performed at Keating. Authorization may be obtained by calling 1-800-KEATING within the Continental United States, Alaska, Hawaii, Puerto Rico and Canada during normal business hours (7:00 a.m. through 6:00 p.m. Central Time, Monday through Friday). When calling, please have the following information available: (1) name, address and telephone number of the Customer; (2) location of product, if different; (3) name, model number and serial number of the product; (4) installation date; and (5) description of defect. Keating will then issue a service authorization work order number to one of its approved independent servicing organizations, or request the product or part be shipped to Keating for repair or replacement, as appropriate. Any defective part subject to a claim under this Limited Warranty must be shipped freight prepaid to Keating for testing and examination. Keating's decision as to the cause and nature of any defect under this Limited Warranty shall be final.

KEATING

KEATING OF CHICAGO, INC., 1-800-KEATING WWW.KEATINGOFCHICAGO.COM

REFILE/warranty 8/07

SERVICE INFORMATION

If you have a service related question call 1-800-KEATING.

Please state the nature of the call; it will ensure speaking with the appropriate person.

Have your serial and model number available when ordering parts.

KEATING OF CHICAGO, INC.

Phone: (708) 246-3000 FAX: (708) 246-3100

Toll Free 1-800-KEATING (In U.S. and Canada)

www.keatingofchicago.com

***As continuous product improvement occurs, specifications may be changed without notice.**

KEATING LIMITED WARRANTY CARD

PLEASE COMPLETE AND MAIL AT ONCE--WARRANTY IS NOT IN EFFECT UNTIL CARD IS RETURNED

COMPANY: _____

ADDRESS: _____

CITY: _____ STATE: _____ ZIP: _____

DEALER: _____

DATE OF PURCHASE: _____ INVOICE NUMBER: _____

SERIAL NUMBER: _____ FRYER FILTER SYSTEM GRIDDLE

REMARKS: _____ TOP-SIDE COOKER HOT PLATE PASTA PLUS

I HAVE READ THE INSTALLATION AND OPERATION INSTRUCTIONS.

SIGNED: _____ DATE: _____

Serving Those Who Serve The Very Best