

VRTIKL-CE FREESTANDING STOVE

MODEL:

- VRT-BZ-N-CE VRT-GY-P-CE
- VRT-GR-N-CE VRT-BZ-B-CE
- VRT-GY-N-CE VRT-GR-B-CE
- VRT-BZ-P-CE VRT-GY-B-CE
- VRT-GR-P-CE

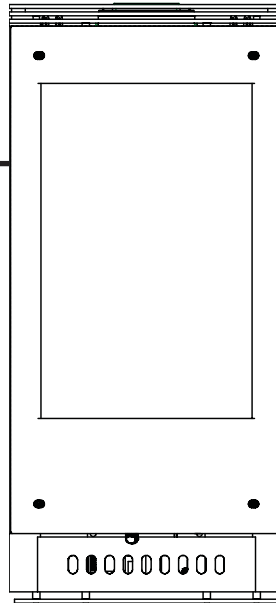

CAUTION



• Important operating and maintenance instructions included.

DO NOT DISCARD THIS MANUAL

• Read, understand and follow these instructions for safe installation and operation.

• Leave this manual with party responsible for use and operation.

⚠ WARNING: If the information in these instructions is not followed exactly, a fire or explosion may result causing property damage, personal injury, or death.

- Do not store or use gasoline or other flammable vapors and liquids in the vicinity of this or any other gas stove.
- **What to do if you smell gas**
 - Do not try to light any gas stove. Do not touch any electrical switch. Do not use any phone in your building.
 - Immediately call your gas supplier from a neighbor's phone. Follow the gas supplier's instructions.
 - If you cannot reach your gas supplier, call the fire department.
- Installation and service must be performed by a qualified installer, service agency, or the gas supplier.

⚠ WARNING



HOT SURFACES!

Glass and other surfaces are hot during operation AND cool down.

Hot glass will cause burns.

- **DO NOT** touch glass until it is cooled
 - **NEVER** allow children to touch glass
 - Keep children away
 - **CAREFULLY SUPERVISE** children in same room as fireplace.
 - Alert children and adults to hazards of high temperatures.
- High temperatures may ignite clothing or other flammable materials.**
- Keep clothing, furniture, draperies and other flammable materials away.

This appliance has been supplied with an integral barrier to prevent direct contact with the fixed glass panel. DO NOT operate the appliance with the barrier removed.

Contact your dealer if the barrier is not present or help is needed to properly install one.

Installation and service of this gas stove should be performed by qualified personnel.

These instructions are valid for the following countries:
GB, IE

Read this manual before installing or operating this gas stove.
Please retain this owner's manual for future reference.

Congratulations

Congratulations on selecting a Heat & Glo gas stove - an elegant and clean alternative to wood burning stoves. The Heat & Glo gas stove you have selected is designed to provide the utmost in safety, reliability, and efficiency.

As the owner of a new gas stove, you'll want to read and carefully follow all of the instructions contained in this *Owner's Manual*. Pay special attention to all Cautions and Warnings.

This Owner's Manual should be retained for future reference. We suggest that you keep it with your other important documents and product manuals.

The information contained in this *Owner's Manual*, unless noted otherwise, applies to all models and gas control systems.

Your new Heat & Glo gas stove will give you years of durable use and trouble-free enjoyment. Welcome to the Heat & Glo family of gas stove products!

SAMPLE OF RATINGS LABEL

LOCATION: IN CONTROL AREA, INSIDE LOWER ACCESS DOOR

Serial No.

SERIAL NO.

HEAT & GLO
Where everything comes together

Heat & Glo, a brand of Hearth & Home Technologies, Inc.
20802 Kensington Boulevard
Lakeville, MN 55044, USA
www.heatnglo.com

CE
0087

Model: **ION-CE**

MADE
IN USA

Gas Type	G20	G20	G20	Q 5
Destination	ES, GB, IE, PT, NO	DE, LU	IR	NL
CAT	I ₂ H	I _{2E}	I _{2E} R	I _{2L}
Q n	7.6	7.6	7.6	6.2
P n	20 mbar	20 mbar	20/25 mbar	25 mbar
P max	8.7 mbar	8.7 mbar	8.7 mbar	8.7 mbar
Injector	#39DMS	#39DMS	#39DMS	#39DMS

Not for use with solid fuel.



"A" measurement is from stove top, not side.

Minimum Clearances to Combustibles

A - Clearance of appliance top to side wall 15.2 cm

B - Clearance of appliance to back wall 7.6 cm

C - Corner of appliance top to side wall 12.7 cm

D - Minimum Alcove Height 137.2 cm

E - Maximum Alcove Depth 91.4 cm

F - Minimum Alcove Width 78.1 cm

G - Top of appliance to alcove ceiling 33.7 cm

H - Mantle Clearance from appliance top 26.7 cm

DO NOT REMOVE OR COVER THIS LABEL.

This appliance must be installed in accordance with the codes enforced, and used only in sufficiently ventilated space. Consult instructions before installation and use of this appliance.

Manufactured by:
HEARTH & HOME
technologies

Date of Manufacture:

2000 2007 2008 Jan | Feb Mar Apr May Jun Aug Sep Oct Nov Dec

Test Lab & Report No.

Model Name

Manufactured Date

- TABLE OF CONTENTS -

Section 1: Listing and Code Approvals

- A. Gas Stove Certifications 4
- B. Glass Specifications 4
- C. Non-Combustible Materials 4
- D. Combustible Materials 4

Section 2: Getting Started

- A. Design & Installation Considerations 5
- B. Inspect Gas Stove & Components 5

Section 3: Gas Stove Location & Clearances

- A. Selecting Gas Stove Location 6
- B. Clearances to Combustibles 6
- C. Optional Stone Surround Installed 7

Section 4: Termination Locations

- A. Flue Termination Clearances 8

Section 5: Flue Information

- A. Flueing Components 10
- B. Use of Elbows 10
- C. Measuring Standards 10
- D. Flueing Diagrams 11
- E. Horizontal Termination 16
- F. Slim Line Wall Thimble 17
- G. Vertical Termination 19
- H. Vertical Flue Restrictor 21

Section 6: Gas Information

- A. Gas Pressure Requirements 22
- B. Gas Connection 22

Section 7: Electrical Information

- A. Ignition System Wiring 23

Section 8: Gas Stove Setup

- A. Remove Shipping Materials 24
- B. Unbolting Gas Stove from the Pallet 24
- C. Leveling and Lagging Down the Gas Stove 24
- D. Accessories 25
- E. Top to Rear Vent Conversion 25
- F. Installing the Baffle 26
- G. Positioning the Logs 27
- H. Mineral Wool 27
- I. Front Door Glass Assembly 28
- J. Inner Glass Door Replacement 28

Section 9: Operating Instructions

- A. Before Lighting Gas Stove 29
- B. Lighting Gas Stove 30
- C. After Gas Stove is Lit 31
- D. Frequently Asked Questions 31

Section 10: Maintaining & Servicing Gas Stove

- A. Maintenance Tasks 33
- B. Service and Maintenance Log 34

Section 11: Troubleshooting 35

Section 12: Reference Materials

- A. Gas Stove Dimension Diagram 35
- B. Gas Stove Dimension with Stone Surround Diagram 36
- C. Flue Components Diagram 37
- D. Flue Components List 38
- E. Service Parts List 40
- F. Warranty Policy 43
- G. Contact Information 44

➔ = Contains updated information.

1

Listing and Code Approvals

A. Appliance Certification

MODEL	VRTIKL-CE
LABORATORY	Gastec Certification B.V.
TYPE	Gas Stove
STANDARD	EN 613:2001
DIRECTIVE	CAD90/396/EEC

These instructions are only valid if the following country symbol is on the gas stove. If this symbol is not present on the gas stove, it is necessary to refer to the technical instructions which will provide the necessary information concerning the modification of the gas stove to the conditions of use for the country.

B. Glass Specifications

This gas stove is equipped with 5mm ceramic glass behind the curved glass. Replace glass only with 5mm ceramic glass. Please contact your dealer for replacement glass.

WARNING

Do NOT use this gas stove if any part has been under water. Immediately call a qualified service technician to inspect the gas stove and to replace any part of the control system and any gas control which has been under water.

C. Non-Combustible Materials

Materials that are reported as passing ASTM E 136, Standard Test Method for Behavior of Materials in a Vertical Tube Furnace at 750°C, shall be considered non-combustible materials.

D. Combustible Materials

Materials made of or surfaced with wood, compressed paper, plant fibers, plastics, or other materials that can ignite and burn, whether flame proofed or not, or whether plastered or unplastered shall be considered combustible materials.

2

Getting Started

A. Design & Installation Considerations

Heat & Glo direct flue gas stoves are designed to operate with all combustion air siphoned from outside of the building and all exhaust gases expelled to the outside. No additional air source is required.

CAUTION

- Check building codes prior to installation.
- Installation **MUST** comply with local, regional, state and national codes and regulations.
 - Consult local building, fire officials or authorities having jurisdiction about restrictions, installation inspection, and permits.

When planning an installation, it is necessary to determine the following information before installing.

- Where the gas stove is to be installed.
- The flue system configuration to be used.
- Gas supply piping.
- Electrical wiring.

B. Inspect Appliance & Components



WARNING

Inspect gas stove and components for damage. Damaged parts may impair safe operation.

- Do NOT install damaged components.
- Do NOT install incomplete components.
- Do NOT install substitute components.

Report damaged parts to dealer.

- Carefully remove the gas stove and components from the packaging.
- Remove door and set aside on protective surface.
- Remove log set and component pack from firebox.
- Report to your dealer any parts damaged in shipment, particularly the condition of the glass.
- **Read all of the instructions before starting the installation. Follow these instructions carefully during the installation to ensure safety and benefit.**



WARNING

Hearth & Home Technologies disclaims any responsibility for, and the **warranty will be voided** by, the following actions:

- Installation and use of any damaged gas stove or flue system component.
- Modification of the gas stove or flue system.
- Installation other than as instructed by Hearth & Home Technologies.
- Improper positioning of the gas logs or the glass door.
- Installation and/or use of any component part not approved by Hearth & Home Technologies.

Any such action may cause a fire hazard.

3 Appliance Location and Clearances

NOTE:

- Illustrations reflect typical installations and are FOR DESIGN PURPOSES ONLY.
- Illustrations/diagrams are not drawn to scale.
- Actual installation may vary due to individual design preference.



WARNING

Fire Risk
Provide adequate clearance:

- Around air openings
- To combustibles
- For service access

Locate gas stove away from traffic areas.

NOTE: For actual gas stove dimensions refer to Section 12.

A. Selecting Appliance Location

When selecting a location for your gas stove it is important to consider the required clearances to walls (see Figure 3.1).

B. Clearances to Combustibles

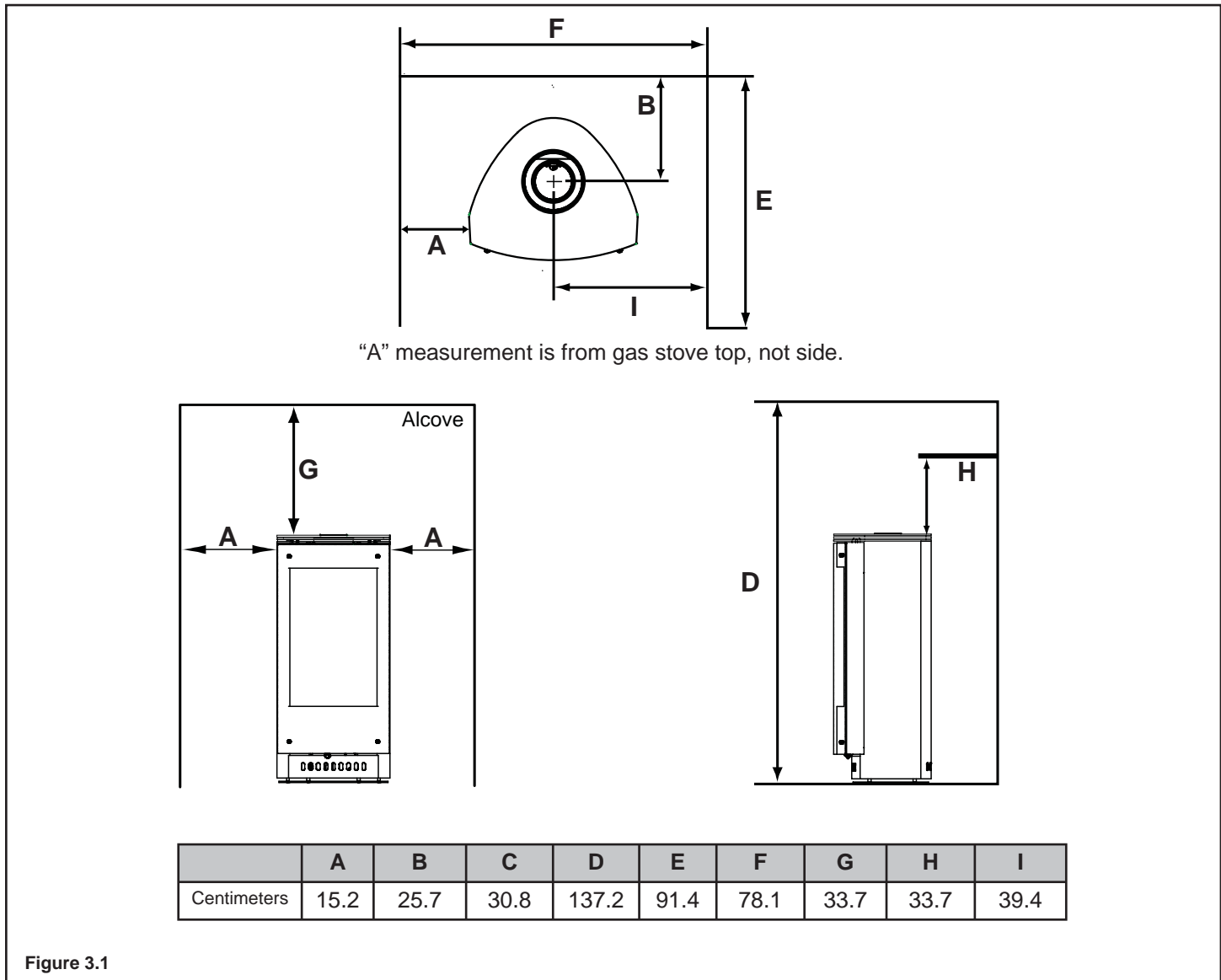
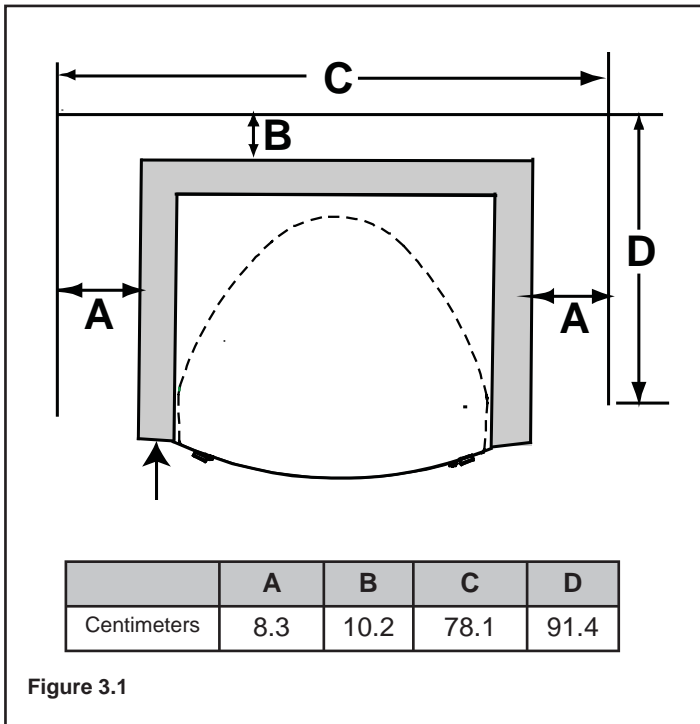

Figure 3.1

C. Optional Stone Surround Installed



WARNING

Fire Risk.
Odor Risk.
Tipping Risk

- Install gas stove on a stable, level platform/ floor strong enough to support gas stove without tipping.
- USE wood flooring, ceramic tile, brick hearth or high pressure laminate flooring applied directly over the sub-flooring material.

4 Termination Locations

A. Flue Termination Minimum Clearances

WARNING

Fire Risk.
Explosion Risk.
 Maintain flue clearance to combustibles as specified.

- Do not pack air space with insulation or other materials.

Failure to keep insulation or other materials away from flue pipe may cause fire.

Measure vertical clearances from this surface.

Measure horizontal clearances from this surface.

(See Figure 4.4 for specific clearances.)

Figure 4.1 Termination Clearances

	Gas Termination	Wood & Fuel Oil Termination
A	15 cm	51 cm

Figure 4.2 Multiple Vertical Termination

Roof Pitch	H (Min.) M
Flat to 6/12.....	.30*
Over 6/12 to 7/12.....	.38*
Over 7/12 to 8/12.....	.46*
Over 8/12 to 9/12.....	.61*
Over 9/12 to 10/12.....	.76
Over 10/12 to 11/12.....	.99
Over 11/12 to 12/12.....	1.22
Over 12/12 to 14/12.....	1.52
Over 14/12 to 16/12.....	1.83
Over 16/12 to 18/12.....	2.13
Over 18/12 to 20/12.....	2.29
Over 20/12 to 21/12.....	2.44

*.91M minimum in snow regions

Figure 4.3 Minimum Height from Roof to Lowest Discharge Opening

Figure 4.3 specifies minimum flue heights for various pitched roofs.

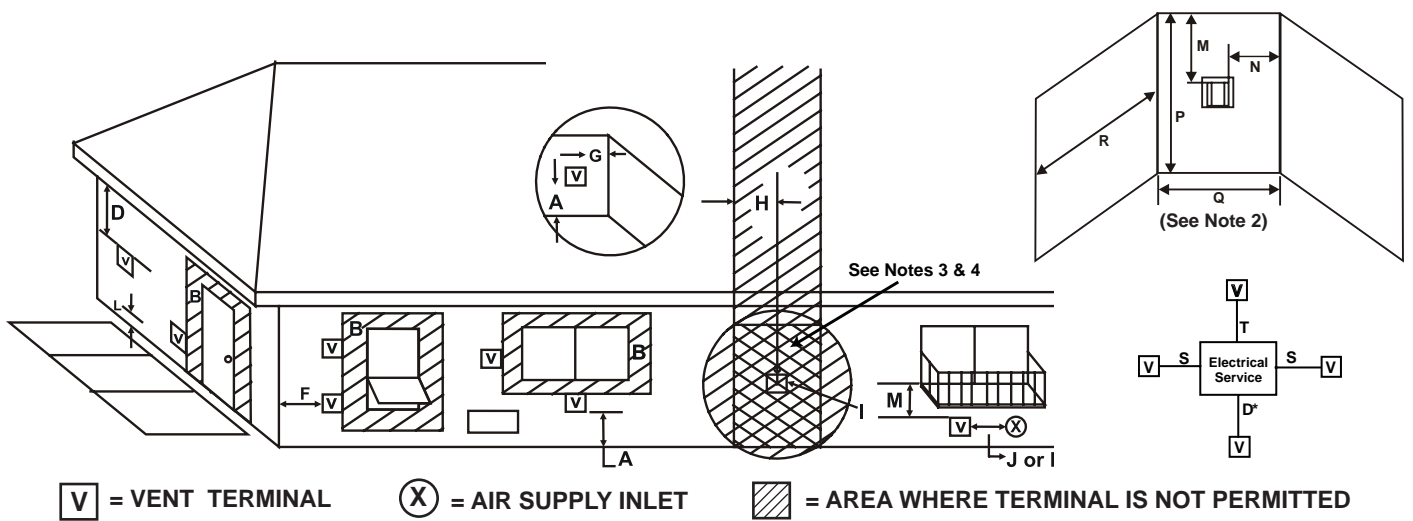

V = VENT TERMINAL **X** = AIR SUPPLY INLET = AREA WHERE TERMINAL IS NOT PERMITTED

<p>A = 31 cmclearances above grade, veranda, porch, deck or balcony (See Note 1)</p> <p>B = 31 cmclearances to window or door that may be opened, or to permanently closed window. (Glass)</p> <p>D* = 31 cmvertical clearance to unventilated soffit or to ventilated soffit located above the terminal 76 cm.....for vinyl clad soffits and below electrical service</p> <p>F = 23 cmclearance to outside corner</p> <p>G = 15 cmclearance to inside corner</p> <p>H = 91 cmnot to be installed above a gas meter/regulator assembly within 90 cm horizontally from the center-line of the regulator</p> <p>I = 1.8 Mclearance to gas service regulator vent outlet</p> <p>J = 31 cmclearance to non-mechanical air supply inlet to building or the combustion air inlet to any other gas stove</p>	<p>K = 1.8 Mclearance to a mechanical (powered) air supply inlet</p> <p>L** = 2.1 Mclearance above paved sidewalk or a paved driveway located on public property (See Note 1)</p> <p>M*** = 46 cmclearance under veranda, porch, deck, balcony or overhang 1.1 Mvinyl</p> <p>S = 15 cmclearance from sides of electrical service (See Note 5)</p> <p>T = 31 cmclearance above electrical service (See Note 5)</p>
---	--

Alcove Applications

N = 15 cmnon-vinyl sidewalls
31 cmvinyl sidewalls

P = 2.4 M

	Q_{MIN}	R_{MAX}
1 cap	.91 M	2 x Q _{ACTUAL}
2 caps	1.8 M	1 x Q _{ACTUAL}
3 caps	2.7 M	2/3 x Q _{ACTUAL}
4 caps	3.7 M	1/2 x Q _{ACTUAL}

Q_{MIN} = # termination caps x 3 **R_{MAX}** = (2 / # termination caps) x Q_{ACTUAL}

** a flue shall not terminate directly above a sidewalk or paved driveway which is located between two single family dwellings and serves both dwellings.

*** only permitted if veranda, porch, deck or balcony is fully open on a minimum of 2 sides beneath the floor, or meets Note 2.

NOTE 1: On private property where termination is less than 7 feet above a sidewalk, driveway, deck, porch, veranda or balcony, use of a listed cap shield is suggested. (See flue components page)

NOTE 2: Termination in an alcove space (spaces open only on one side and with an overhang) are permitted with the dimensions specified for vinyl or non-vinyl siding and soffits. 1. There must be 2.7M minimum between termination caps. 2. All mechanical air intakes within 3M of a termination cap must be a minimum of 2.7M below the termination cap. 3. All gravity air intakes within 2.7M of a termination cap must be a minimum of .31M foot below the termination cap.

NOTE 3: Local codes or regulations may require different clearances.

NOTE 4: Termination caps may be hot. Consider their proximity to doors or other traffic areas.

NOTE 5: Location of the flue termination must not interfere with access to the electrical service.

Heat & Glo assumes no responsibility for the improper performance of the gas stove when the flueing system does not meet these requirements.

Figure 4.4 Minimum Clearances for Termination

5

Flue Information

A. Flue Components

These models are approved to use Simpson Dura-Vent or Hearth & Home Technologies series pipes, components and termination. Approved components are labeled for identification. This pipe is tested and listed as an approved component of the stove.

DO NOT USE FIELD-FABRICATED FLUE COMPONENTS.
Refer to the flue manufacturer's instructions.

This product is approved to be flued either horizontally, through the side wall or vertically through the roof. You may flue through a Class A or masonry chimney if an approved adapter is used.

This gas stove is a balanced flue gas stove. All combustion air must come directly from the outside of the building. The flue pipe for this unit consists of an inner and an outer pipe. The inner pipe carries the gas stove exhaust out of the system, and the outer pipe brings fresh combustion air into the gas stove.

- A round support box/wall thimble or heat shield is required when the flueing passes through a combustible wall.
- A support box or ceiling firestop is required when the flueing passes through a combustible ceiling.
- Roof flashing and a storm collar are required when flueing passes through the roof.
- Follow instructions provided with the flueing for installation of these items.



WARNING



Fire Hazard.
Explosion Risk.
Asphyxiation Risk.

Do NOT connect this gas stove to a chimney flue serving a separate solid-fuel or gas burning gas stove.

- Flue this gas stove directly outside.
- Use separate flue system for this gas stove.



May impair safe operation of this gas stove or other gas stoves connected to the flue.

B. Use of Elbows

CAUTION

ALL flue configuration specifications MUST be followed.

- This product is tested and listed to these specifications.
- Appliance performance will suffer if specifications are not followed.

Diagonal runs have both vertical and horizontal flue aspects when calculating the effects. Use the rise for the vertical aspect and the run for the horizontal aspect. (See **Figure 5.1.**)

Two 45° elbows may be used in place of one 90° elbow. On 45° runs, one foot of diagonal is equal to 21.6 cm horizontal run and 21.6 cm vertical run. A length of straight pipe is allowed between two elbows. (See **Figure 5.1.**)

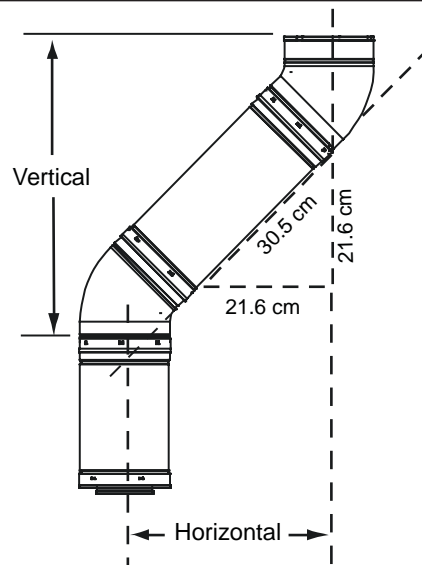

Figure 5.1

C. Measuring Standards

Vertical and horizontal measurements were made using the following standards.

- Pipe measurements are from center line to center line.
- Horizontal terminations are measured to the outside of the mounting surface (flange of termination cap). See **Figure 4.1** on page 8.
- Horizontal pipe should be installed level with no rise.

D. Flueing Diagrams

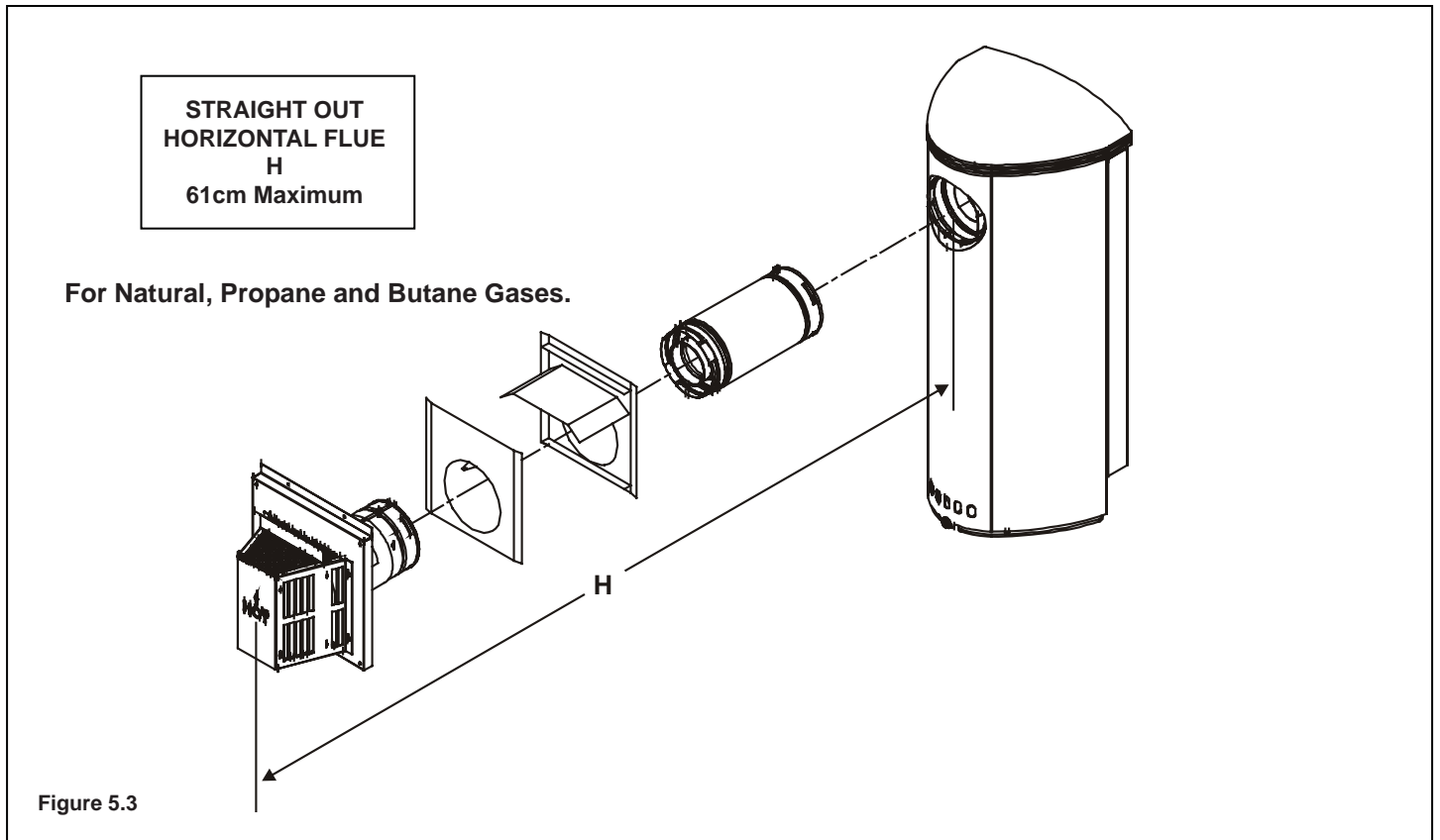
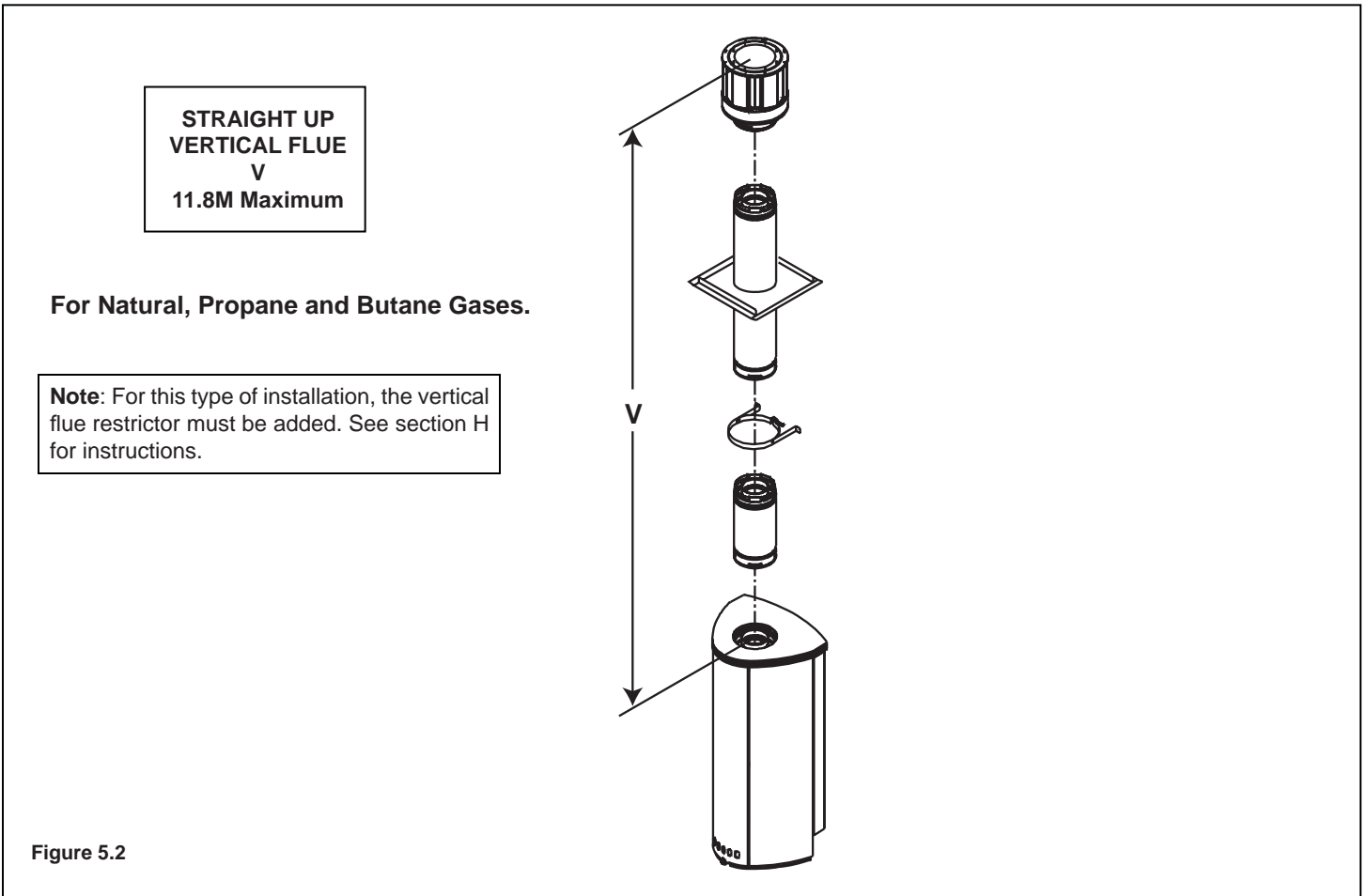

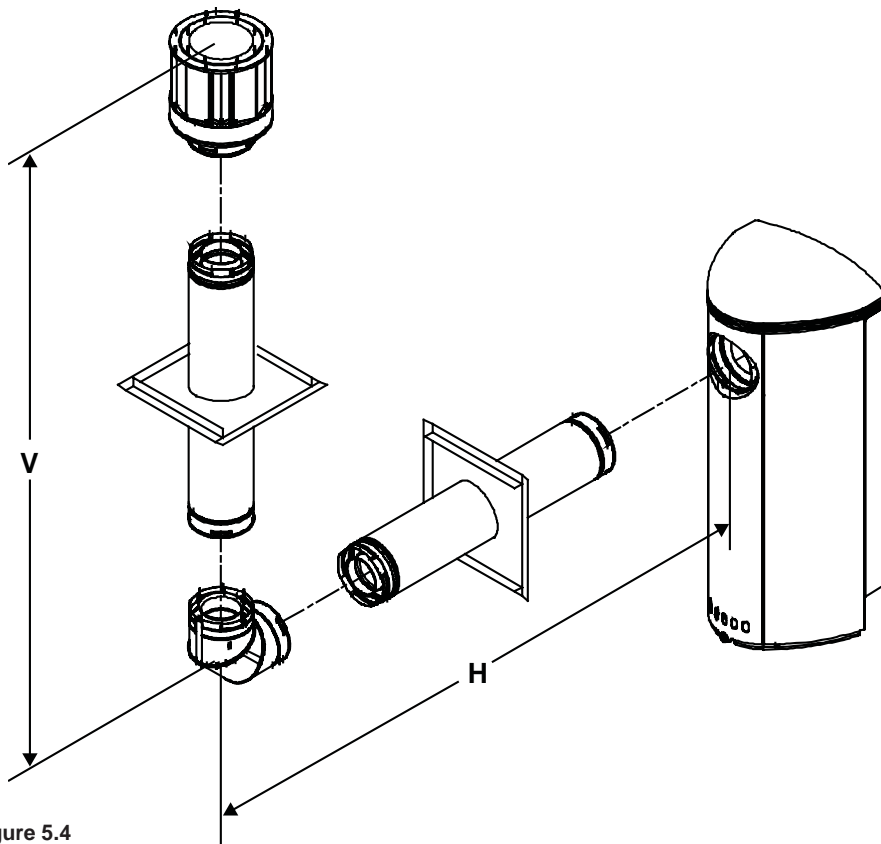

Figure 5.4

Natural Gas • One 90° Elbow System	
V Minimum	H Maximum
46 cm	1.3 M
92 cm	2.7 M
1.4 M	4.1 M
1.8 M	5.0 M
V+H = Max 11.6 M H Max = 5.0 M	

Propane • One 90° Elbow System	
V Minimum	H Maximum
46 cm	92 cm
92 cm	1.8 M
1.4 M	2.8 M
1.8 M	3.6 M
V+H = Max 11.6 M H Max = 3.6 M	

Butane • One 90° Elbow System	
V Minimum	H Maximum
46 cm	46 cm
92 cm	92 cm
1.4 M	1.4 M
1.8 M	1.8 M
V+H = Max 10 M H Max = 1.8 M	

Natural Gas • One 90° Elbow System	
V Minimum	H Maximum
46 cm	1.3 M
92 cm	2.7 M
1.4 M	4.1 M
1.8 M	5.0 M
V+H = Max 11 M H Max = 5.0 M	

Propane • One 90° Elbow System	
V Minimum	H Maximum
46 cm	92 cm
92 cm	1.8 M
1.4 M	2.8 M
1.8 M	3.6 M
V+H = Max 11 M H Max = 3.6 M	

Butane • One 90° Elbow System	
V Minimum	H Maximum
1.22 M	92 cm
1.4 M	1.4 M
1.8 M	1.8 M
V+H = Max 10 M H Max = 1.8 M	

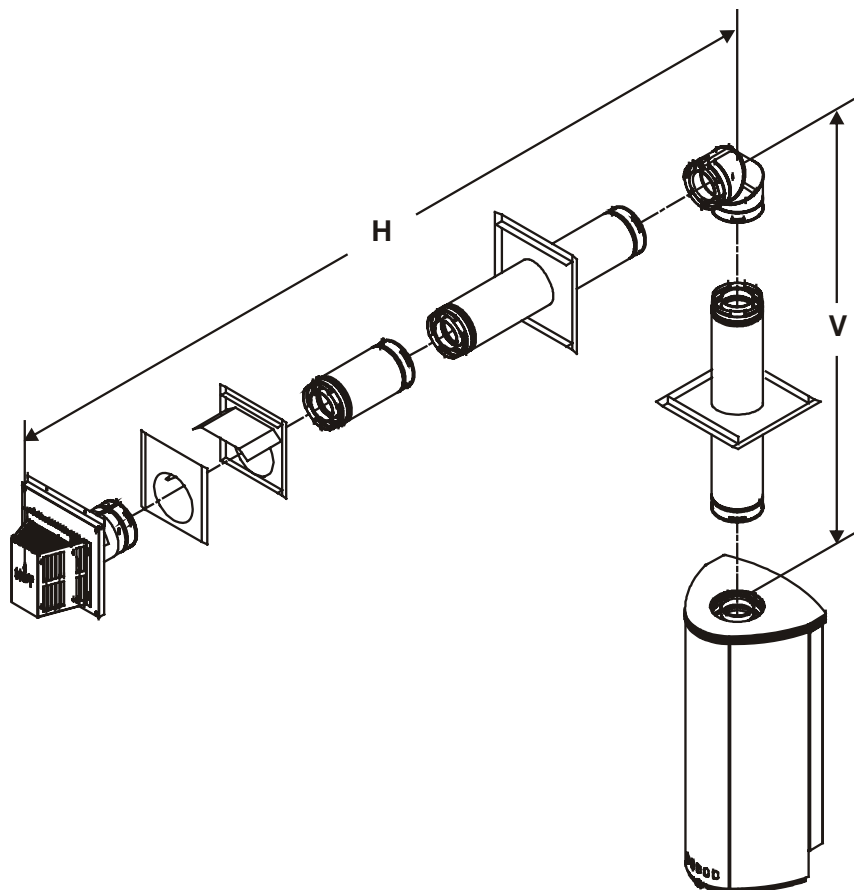

Figure 5.5

Natural Gas • Two 90° Elbows System		
V Min.	H1 Max.	H1 + H2 Max.
46 cm	55 cm	1.1 M
92 cm	1.1 M	2.2 M
1.4 M	1.7 M	3.5 M
1.8 M	2.2 M	4.5 M
V+H1+H2 = Max 11.0M H1 Max = 2.2M H1+H2 = Max 4.5M		

Propane • Two 90° Elbows System		
V Min.	H1 Max.	H1 + H2 Max.
46 cm	39 cm	69 cm
92 cm	75 cm	1.3 M
1.4 M	1.1 M	2.1 M
1.8 M	1.5 M	2.7 M
V+H1+H2 = Max 10.6M H1 Max = 1.5M H1+H2 = Max 2.7M		

Butane • Two 90° Elbows System		
V Min.	H1 Max.	H1 + H2 Max.
1.22 M	48 cm	61 cm
1.4 M	.5 M	.7 M
1.8 M	.7 M	.9 M
V+H1+H2 = Max 10M H1 Max = .7M H1+H2 = Max .9M		

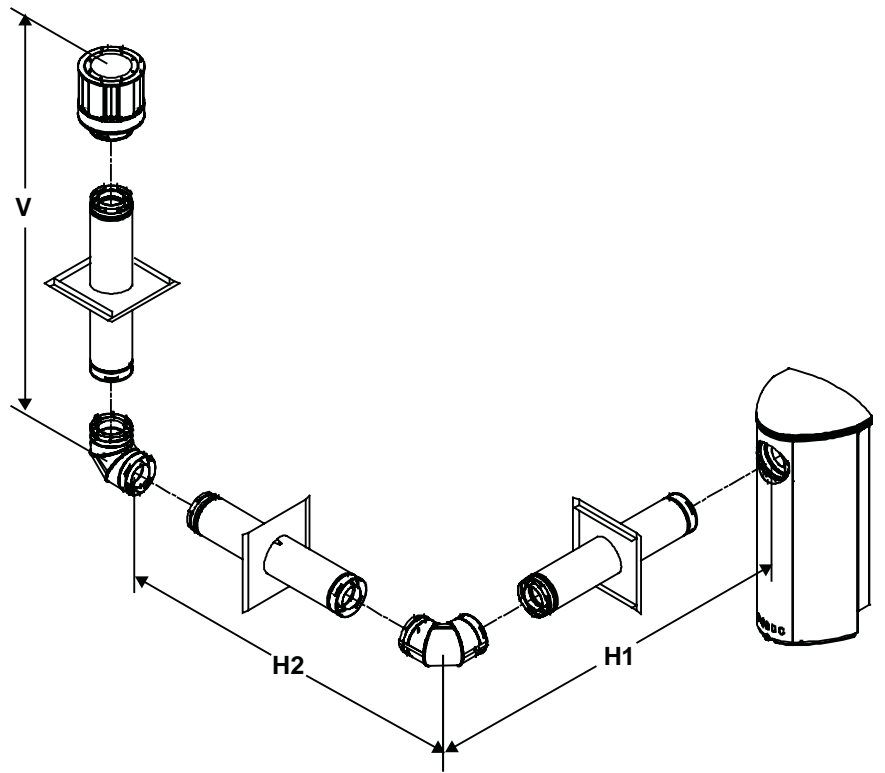

Figure 5.6

Natural Gas • Two 90° Elbows System		
V Min.	H1 Max.	H1 + H2 Max.
46 cm	55 cm	1.1 M
92 cm	1.1 M	2.3 M
1.4 M	1.7 M	3.5 M
1.8 M	2.2 M	4.5 M
V+H1+H2 = Max 10M H1 Max = 2.2M H1+H2 = Max 4.5M		

Propane • Two 90° Elbows System		
V Min.	H1 Max.	H1 + H2 Max.
46 cm	39 cm	69 cm
92 cm	75 cm	1.3 M
1.4 M	1.1 M	2.1 M
1.8 M	1.5 M	2.7 M
V+H1+H2 = Max 10M H1 Max = 1.5M H1+H2 = Max 2.7M		

Butane • Two 90° Elbows System		
V Min.	H1 Max.	H1 + H2 Max.
1.22 M	48 cm	61 cm
1.4 M	.5 M	.7 M
1.8 M	.7 M	.9 M
V+H1+H2 = Max 10M H1 Max = .7 H1+H2 = Max .9M		

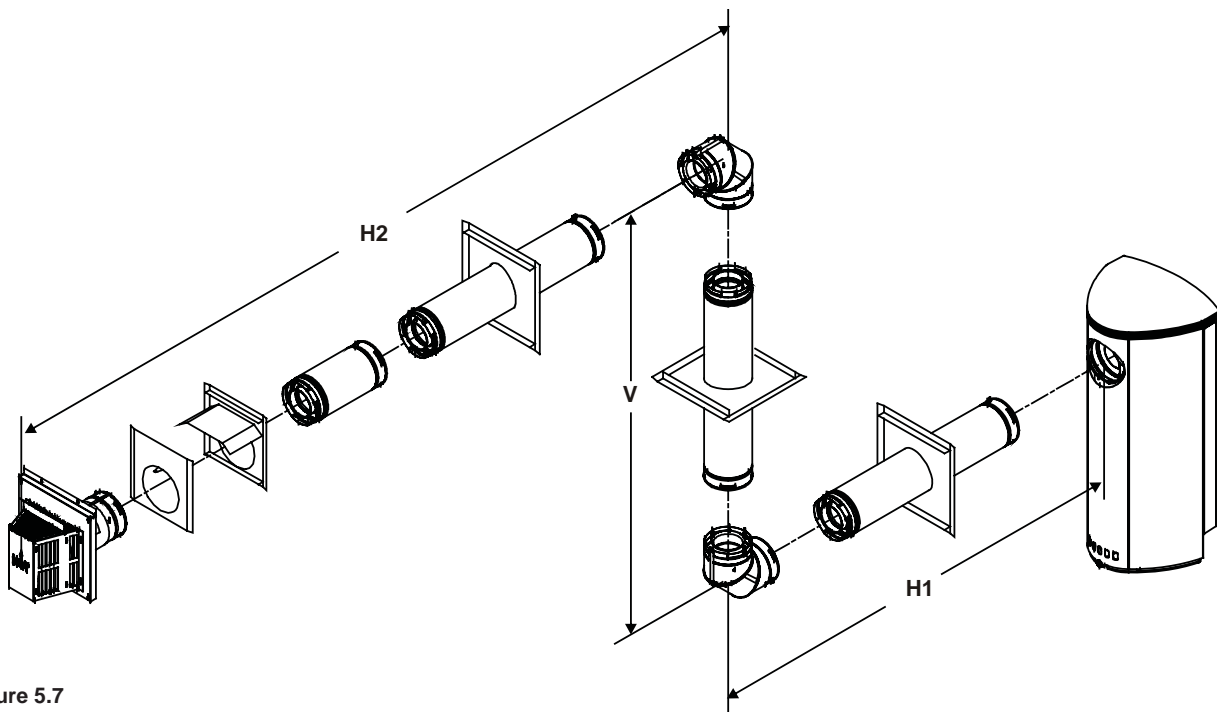

Figure 5.7

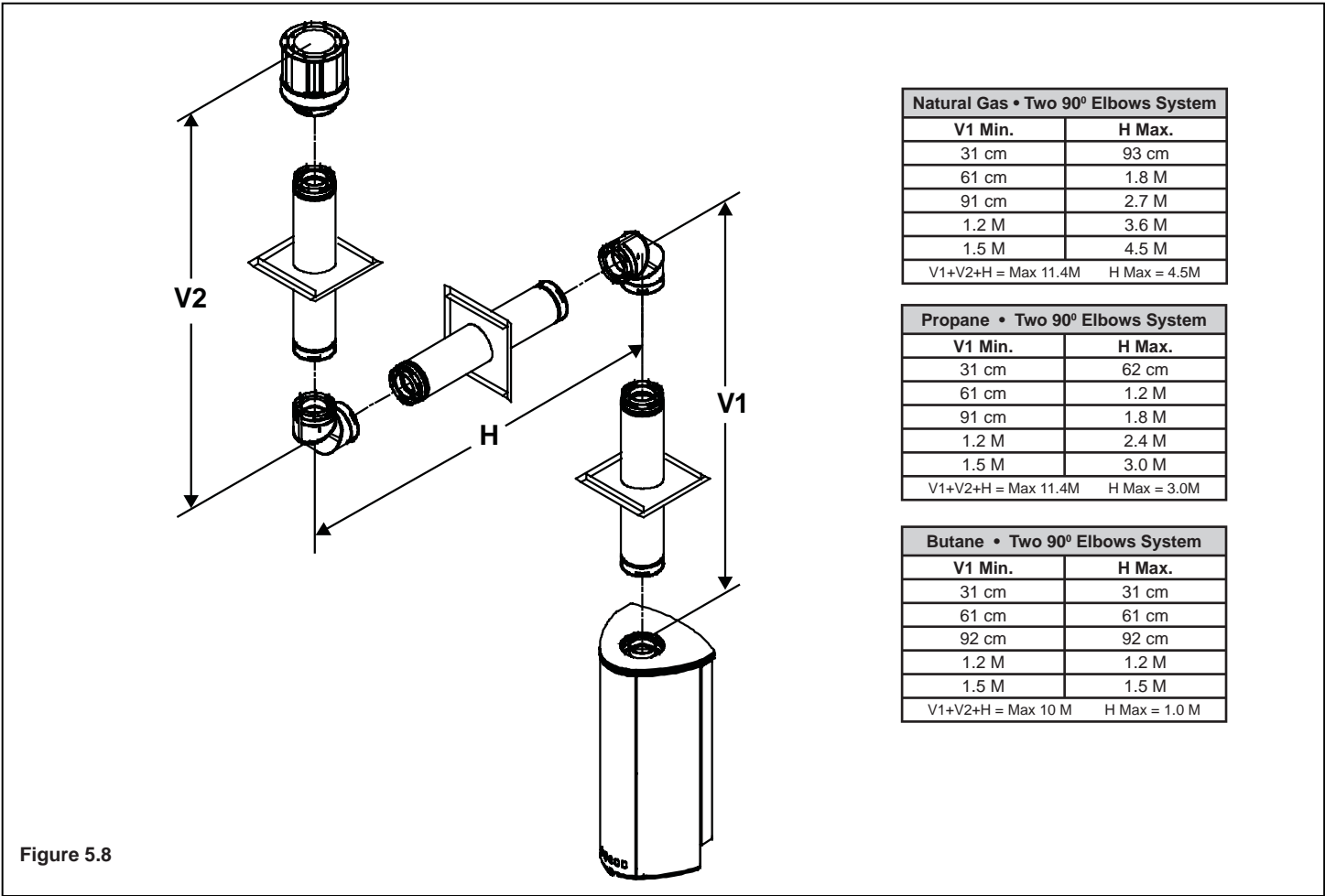

Figure 5.8

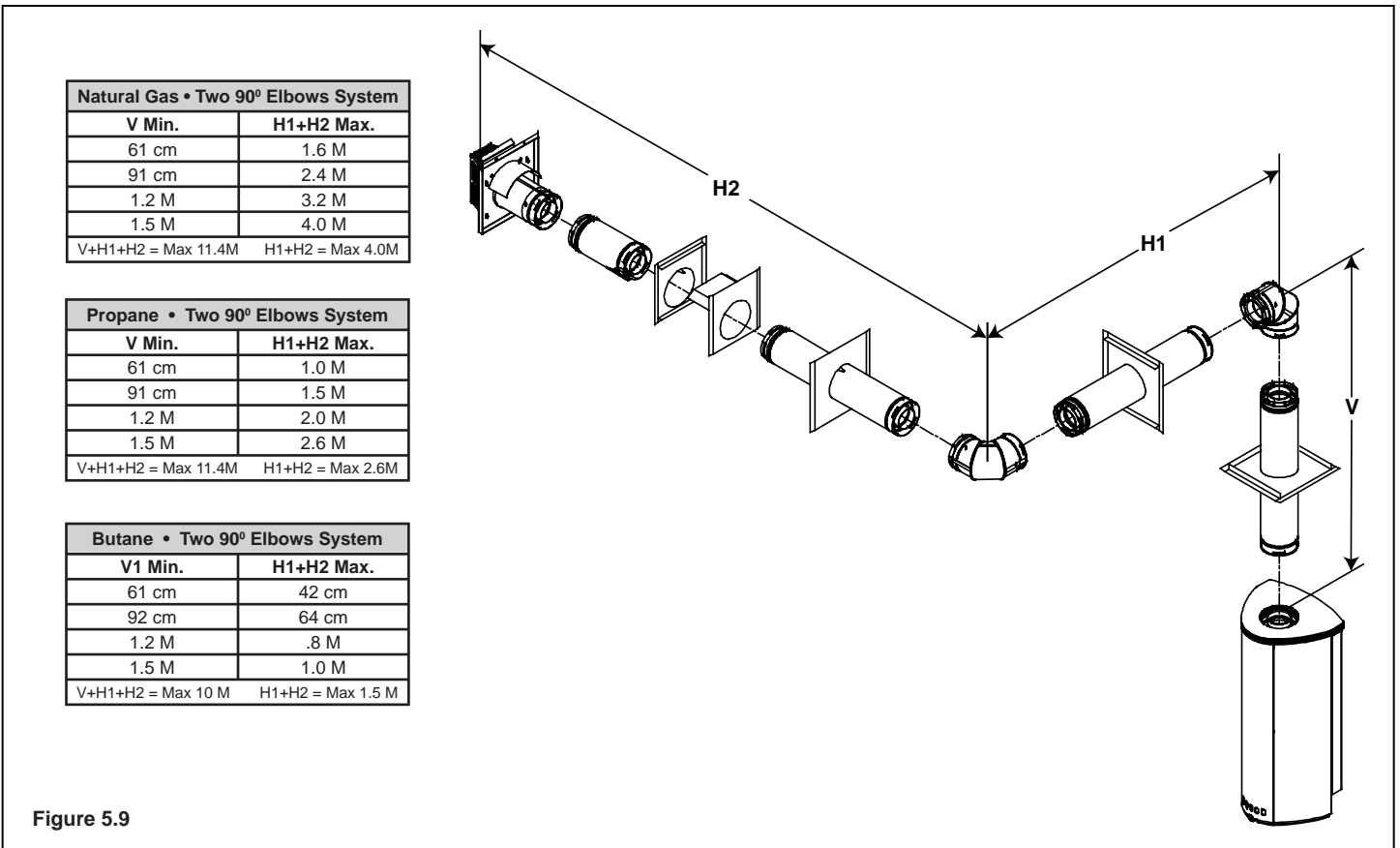

Figure 5.9

Natural Gas • Three 90° Elbows System		
V1 Min.	H1 Max.	H1 + H2 Max.
46 cm	55 cm	1.1 M
92 cm	1.1 M	2.3 M
1.4 M	1.7 M	3.5 M
1.8 M	2.2 M	4.5 M
V1+V2+H1+H2=Max 11M H1 Max=2.2M H1+H2=Max 4.5M		

Propane • Three 90° Elbows System		
V1 Min.	H1 Max.	H1 + H2 Max.
46 cm	34 cm	69 cm
92 cm	65 cm	1.3 M
1.4 M	1.0 M	2.1 M
1.8 M	1.8 M	2.7 M
V1+V2+H1+H2=Max 11M H1 Max=1.8M H1+H2=Max 2.7M		

Butane • Three 90° Elbows System		
V1 Min.	H1 Max.	H1 + H2 Max.
46 cm	14 cm	32 cm
92 cm	23 cm	64 cm
1.4 M	35 cm	.8 M
1.8 M	45 cm	1.0 M
V1+V2+H1+H2=Max 10M H1 Max=45cm H1+H2=Max 1.0M		

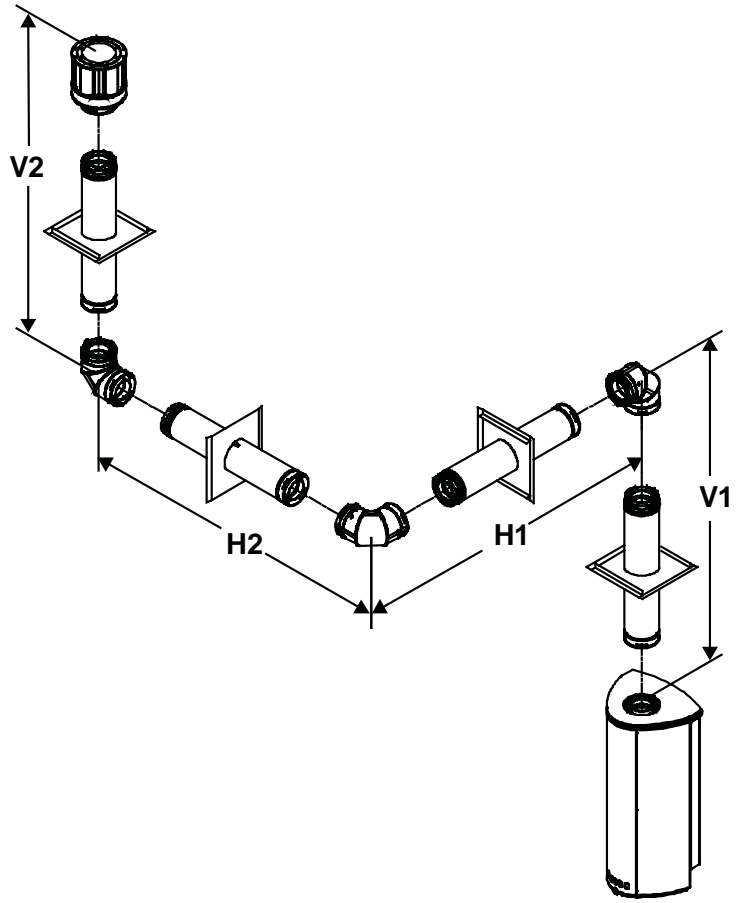
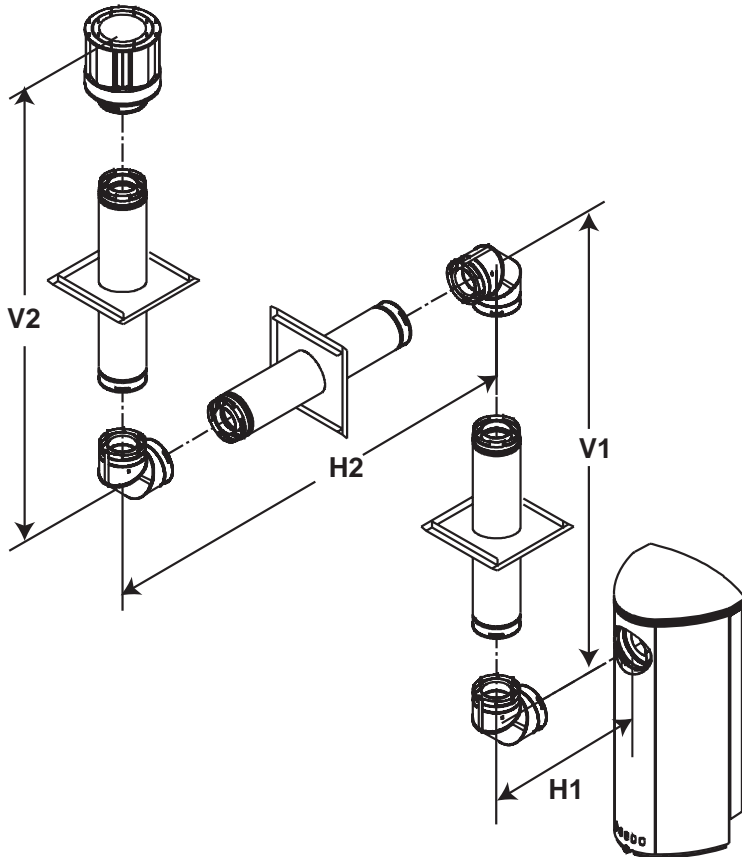

Figure 5.10



Natural Gas • Three 90° Elbows System		
V1 Min.	H1 Max.	H1 + H2 Max.
46 cm	55 cm	1.0 M
92 cm	1.1 M	2.0 M
1.4 M	1.7 M	3.0 M
1.8 M	2.2 M	3.9 M
V1+V2+H1+H2=Max 11M H1 Max=2.2M H1+H2=Max 3.9M		

Propane • Three 90° Elbows System		
V1 Min.	H1 Max.	H1 + H2 Max.
46 cm	34 cm	55 cm
92 cm	65 cm	1.1 M
1.4 M	1.0 M	1.6 M
1.8 M	1.8 M	2.1 M
V1+V2+H1+H2=Max 10M H1 Max=1.8M H1+H2=Max 2.1M		

Butane • Three 90° Elbows System		
V1 Min.	H1 Max.	H1 + H2 Max.
64 cm	16 cm	32 cm
92 cm	23 cm	36 cm
1.4 M	35 cm	.7 M
1.8 M	45 cm	.9 M
V1+V2+H1+H2=Max 10M H1 Max=45 cm H1+H2=Max .9M		

Figure 5.11

E. Horizontal Termination

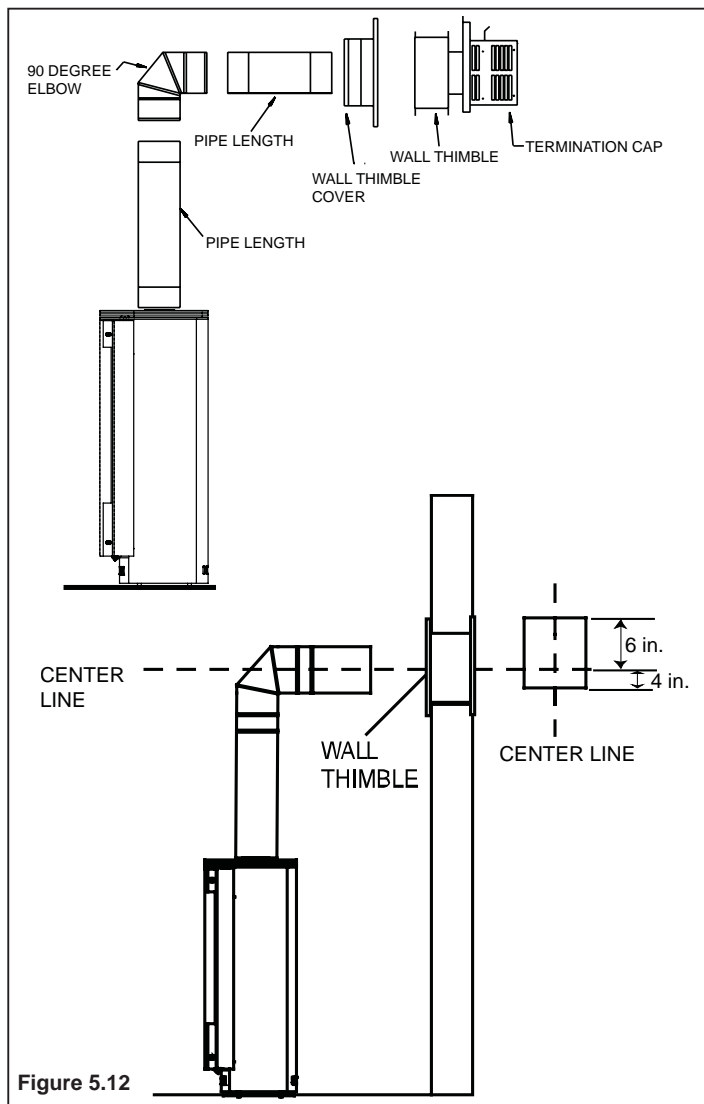





Figure 5.12

Step 1.

Determine the desired location of the gas stove. Check to ensure that wall studs or roof rafters are not in the way when the flue system is being planned. If this is the case, you may want to adjust the location of the gas stove.

 WARNING	
	
<p>Fire Hazard. Exhaust Fume Risk. Impaired Performance of Appliance.</p> <ul style="list-style-type: none"> • Ensure flue components are locked together correctly. • Pipe may separate if not properly joined. 	

Step 2.

Balanced flue pipe is designed with a locking connection. To connect the flue system to the gas stove flue outlet, a twist-lock adapter is built into the gas stove at the factory. Wall thickness may vary. Remember to include wall thickness in minimum clearances when figuring flueing lengths for your installation needs.

Note: Female ends of balanced flue pipe/elbows are designed to slide straight onto the male ends of adjacent pipes by orienting the pipe indentations so they match and slide into the entry slots on the male ends, see **Figure 5.13**. Push the pipe sections completely together, then twist-lock one section clockwise approximately one-quarter turn, until the two sections are fully locked. The female locking lugs may not be visible from the outside. They may be located by examining the inside of the female ends.

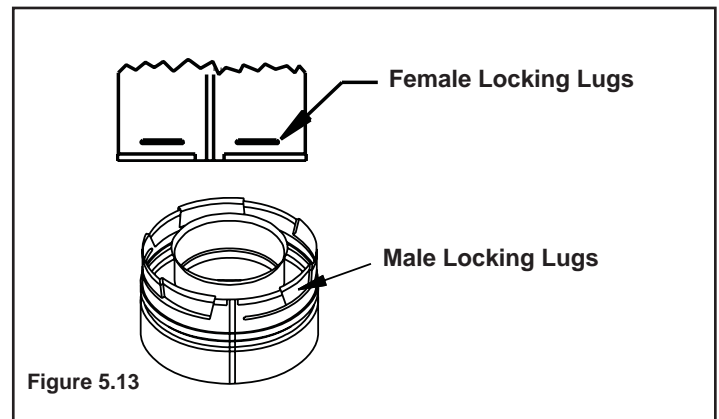





Figure 5.13

 WARNING	
	<p>Fire Risk. Explosion Risk. Combustion Fume Risk. Use flue run supports per installation instructions. Connect flue sections per installation instructions.</p>
	<ul style="list-style-type: none"> • Maintain all clearances to combustibles. • Do NOT allow flue to sag below connection point to gas stove. <p>Improper support may allow flue to sag or separate.</p>

Step 3.

For installations using a round support box/wall thimble (check pipe manufacturer's instructions), mark the wall for a 25.4 cm x 25.4 cm square hole. The center of the square hole should line up with the center line of the horizontal pipe, as shown in **Figure 5.12**. Cut and frame the hole in the exterior wall where the flue will be terminated. If the wall being penetrated is constructed of noncombustible material, i.e. masonry block or concrete, a 17.8 cm diameter hole is acceptable.

Step 4.

Position the horizontal termination cap in the center of the 25.4cm x 25.4cm square hole and run a bead of non-hardening mastic around its outside edges, to make a seal between it and the wall. Attach termination cap to the exterior wall with the four wood screws provided. The arrow on the flue cap should be pointing up.

F. Slim Line Wall Thimble

BEFORE YOU BEGIN:

Review the flueing configurations in **Figures A, B and C** on the next page.

1. Assembling Slim Line Trim Ring and Heat Shield

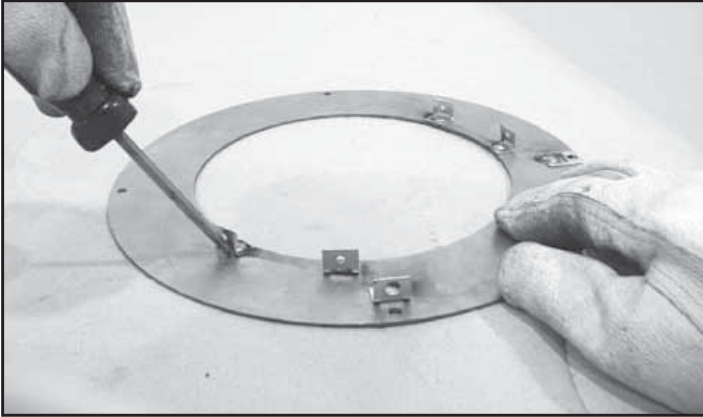

Figure 5.14

Lay the trim ring on flat surface and bend up the six welded brackets into a 90 degree position. The brackets along the outer edge of the ring are for locating the ring in the center of the hole.

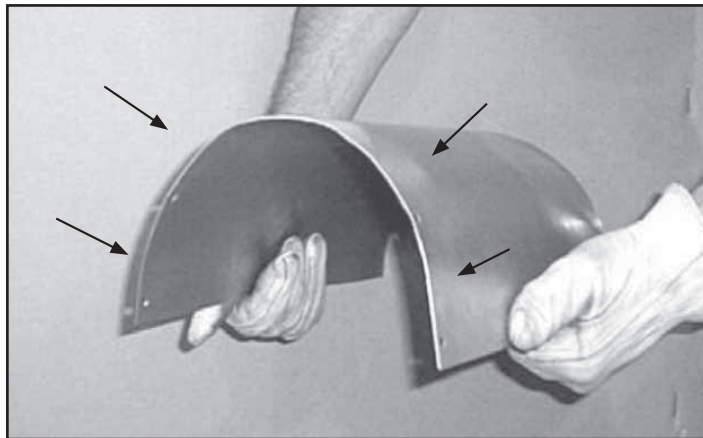



Figure 5.15

The heat shield is shipped flat and must be hand bent into a half circle before attaching it to the trim ring. Bend the heat shield as shown.

CAUTION	
	
Sharp Edges	
<ul style="list-style-type: none">• Wear protective gloves and safety glasses during installation.	

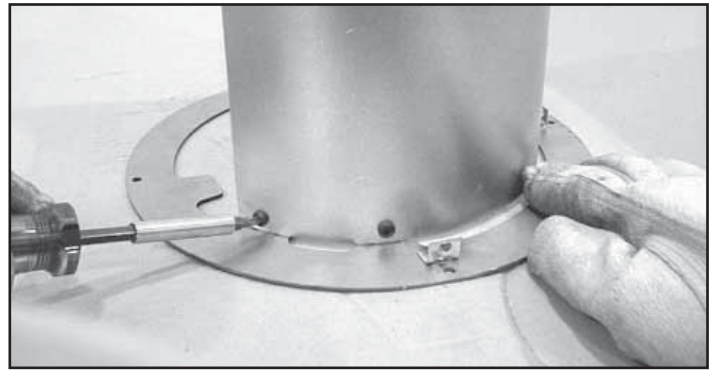

Figure 5.16

Attach the heat shield to the trim ring with the four screws provided. Screws go through the heat shield and into the brackets on the trim ring.

2. Installing Slim Line Trim Ring and Heat Shield

Measure from the floor to the center of the flue pipe. Cut out a 25.4 cm hole in the wall. Hold the trim ring/heat shield assembly in place and put a mark on the shield with a black marker where it protrudes through the exterior wall. **Figure A** on the next page.

Use that mark as a guide to trim off excess heat shield with a pair of sheet metal shears.

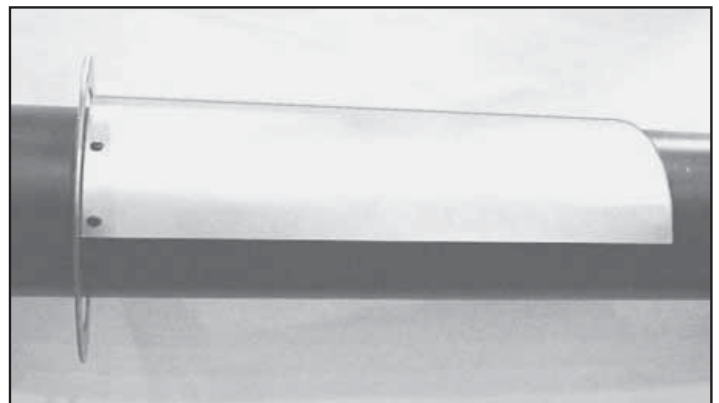

Figure 5.17

When installing the trim ring/heat shield assembly make sure the trim ring is centered in the hole and that the shield is above the pipe. There must be a minimum of 2 cm minimum clearance maintained to combustibles from the top of the heat shield.

Ensure that framing on the inside of the wall is a minimum inner framing diameter of 25.4 cm x 25.4 cm.

The four trim ring mounting screws provided should be replaced with appropriate fasteners for stucco, brick, concrete, or other types of sidings.

FIG. A 90 DEGREE ELBOW

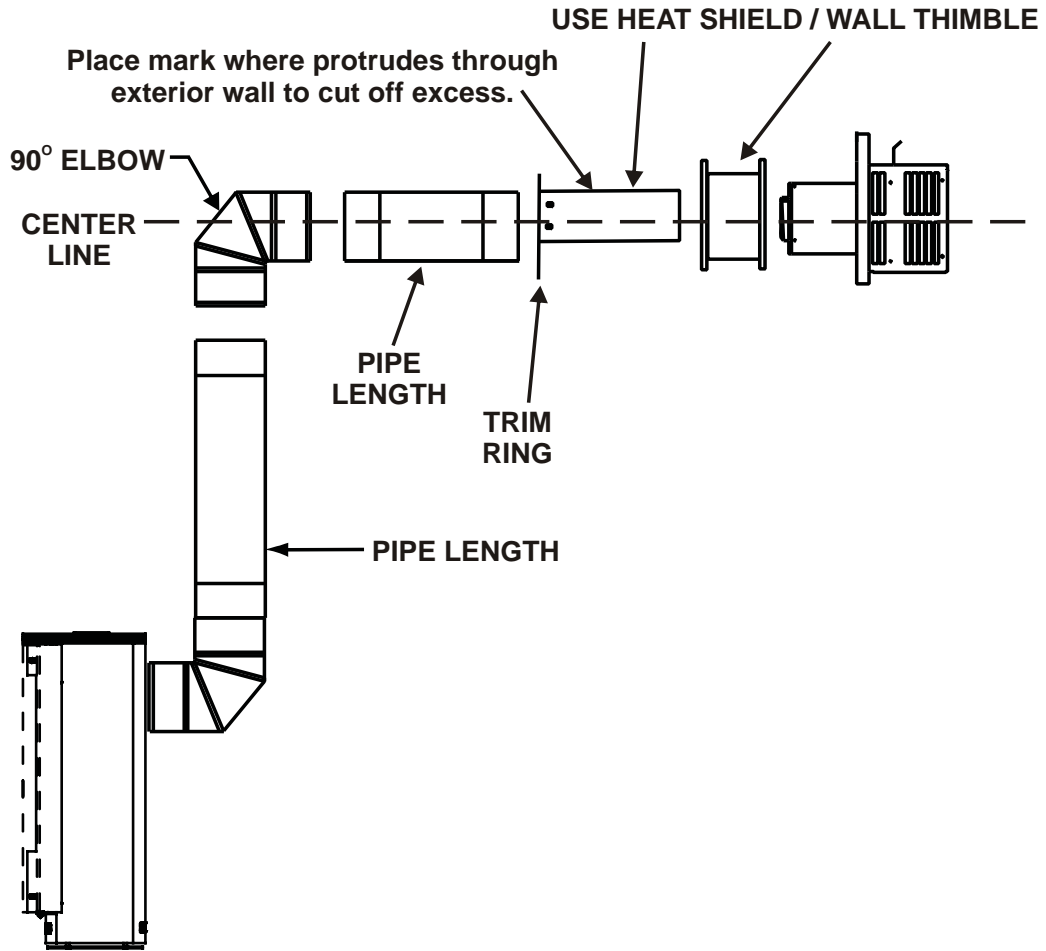

FIG. B MINIMUM CLEARANCE

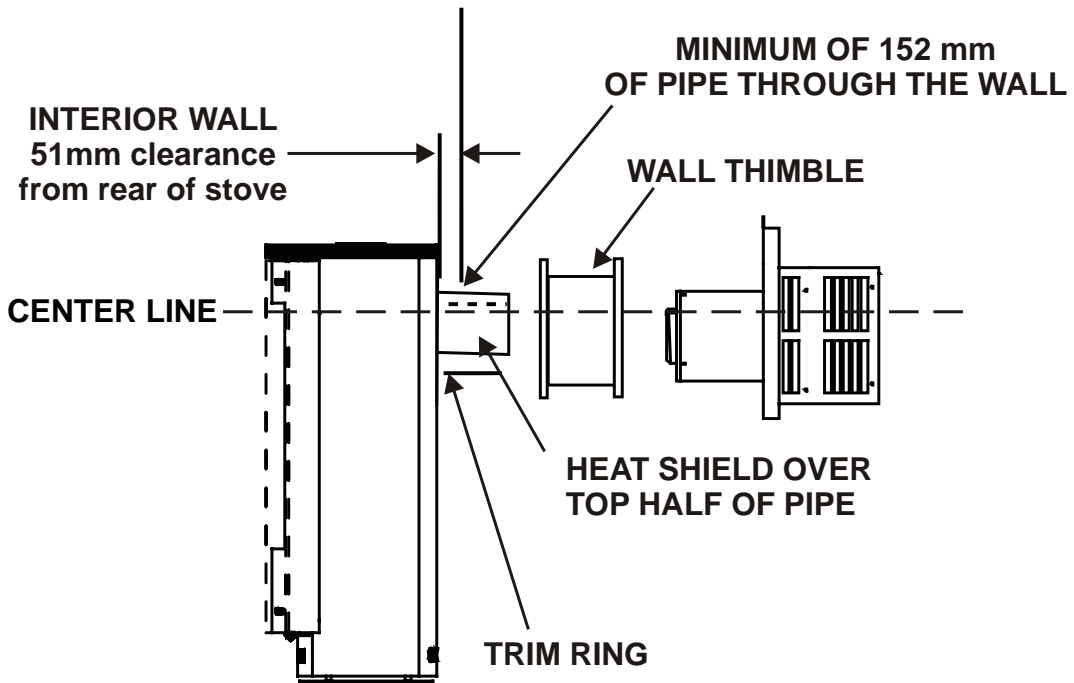
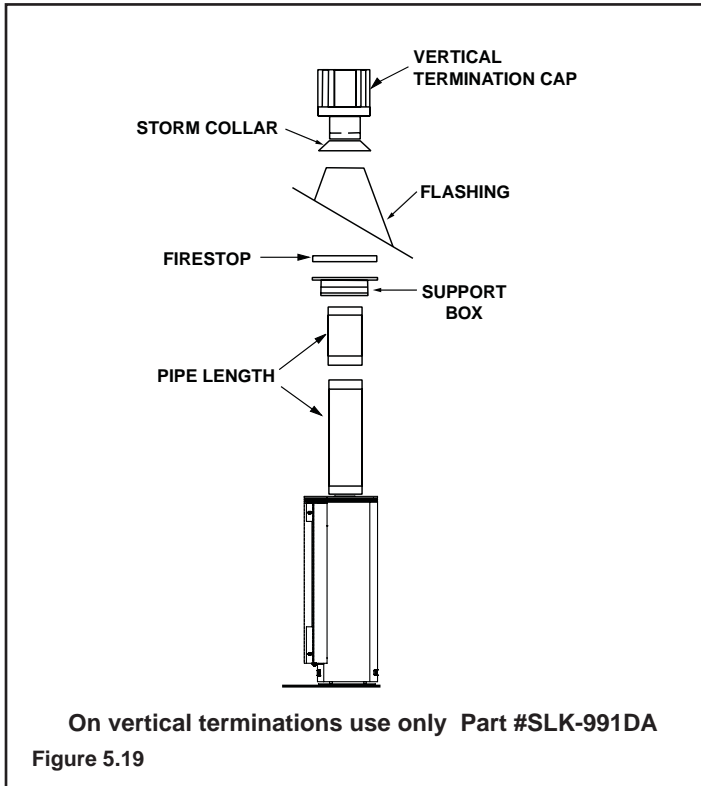

Figure 5.18

G. Vertical Termination

1. Balance Flue Pipe



Step 1.

Check the installation instructions for required 2.5 cm clearances (air space) to combustibles when passing through ceilings, walls, roofs, enclosures, attic rafters, or other nearby combustible surfaces. (See **Figure 5.14**). Check the instructions for maximum vertical rise of the flueing system, and any maximum horizontal offset limitations. All offsets must fall within the set parameters of the flue charts (**Figure 5.2**) located on pages 11-15.

NOTE: Maximum vertical rise allowable is 11.8 M, **Figure 5.2**.

	WARNING
	<p>Fire Risk.</p> <p>Explosion Risk.</p> <p>Maintain flue clearance to combustibles as specified.</p> <ul style="list-style-type: none"> Do not pack air space with insulation or other materials.
	<p>Failure to keep insulation or other materials away from flue pipe may cause fire.</p>

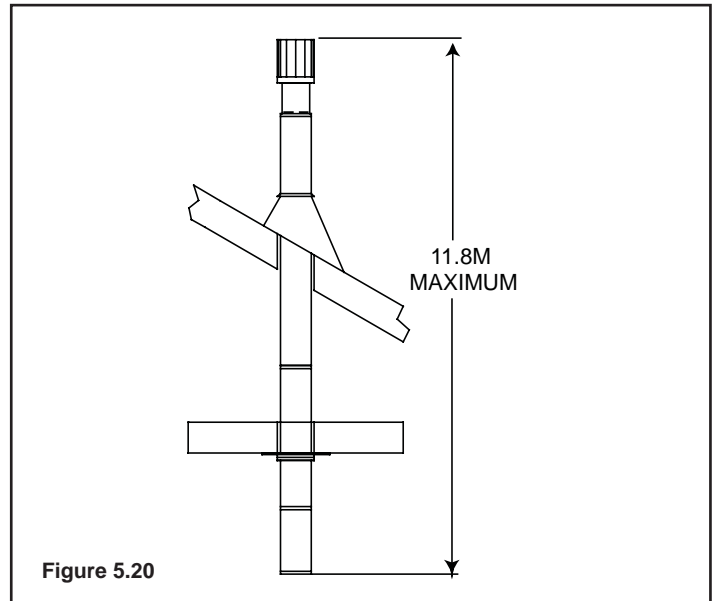

Step 2.

Set the gas stove in its desired location. Drop a plumb bob down from the ceiling to the position of the gas stove flue exit, and mark the location where the flue will penetrate the ceiling. Drill a small hole at this point. Next, drop a plumb bob from the roof to the hole previously drilled in the ceiling, and mark the spot where the flue will penetrate the roof. Determine if ceiling joists, roof rafters, or other framing will obstruct the flueing system. You may wish to relocate the gas stove, or to offset, as shown in **Figure 5.21** to avoid cutting load bearing members.

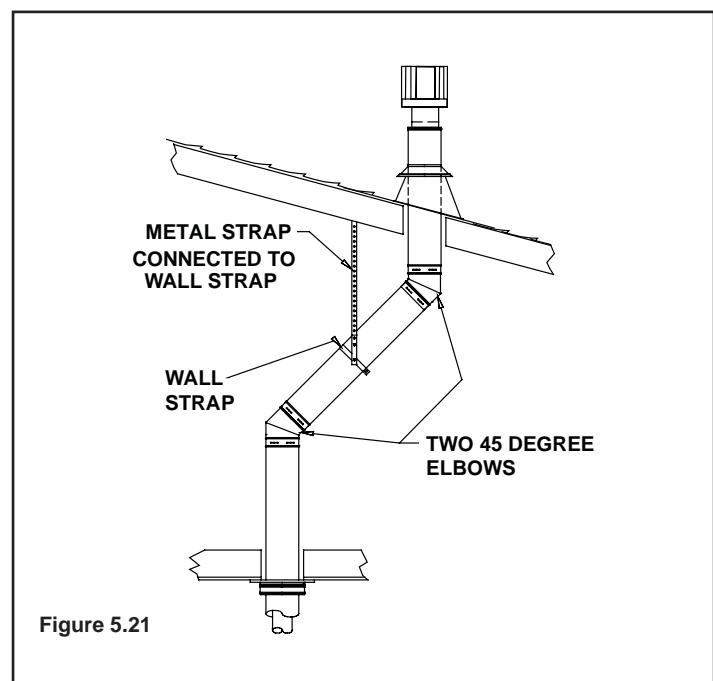

Step 3.

To install the round support box/wall thimble cover in a flat ceiling, cut a 25.4cm square hole in the ceiling, centered on the hole drilled in Step 2. Frame the hole as shown in **Figure 5.22**.

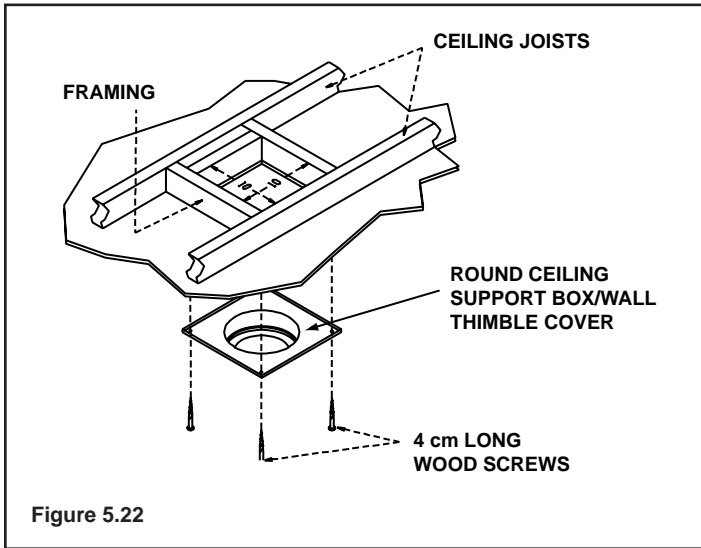

Step 4.

Assemble the desired lengths of pipe and elbows necessary to reach from the gas stove up through the round support box. Ensure that all pipe and elbow connections are in their fully twist-locked position. Assemble as instructed.

Step 5.

Cut a hole in the roof centered on the small drill hole placed in the roof in Step 2. The hole should be of sufficient size to meet the minimum requirements for clearance to combustibles, as specified. Continue to assemble lengths of pipe and elbows necessary to reach from the ceiling support box/wall thimble up through the roof line. Galvanized pipe and elbows may be utilized in the attic, as well as above the roofline. The galvanized finish is desirable above the roofline, due to its higher corrosion resistance (compared to black pipe).

NOTE:

- (1) If an offset is necessary in the attic to avoid obstructions, it is important to support the flue pipe every 91.4cm to avoid excessive stress on the elbows, and possible separation. Wall straps are available for this purpose, **Figure 5.10**, page 15.
- (2) Whenever possible, use 45° elbows, instead of 90° elbows. The 45° elbow offers less restriction to the flow of flue gases and intake air.

Step 6.

Slip the flashing over the pipe section(s) protruding through the roof. Secure the base of the flashing to the roof with roofing nails. Ensure the roofing material overlaps the top edge of the flashing as shown in **Figure 5.23**. Verify that the chimney is the required height above the roof. See roof pitch table, **Figure 4.3**.

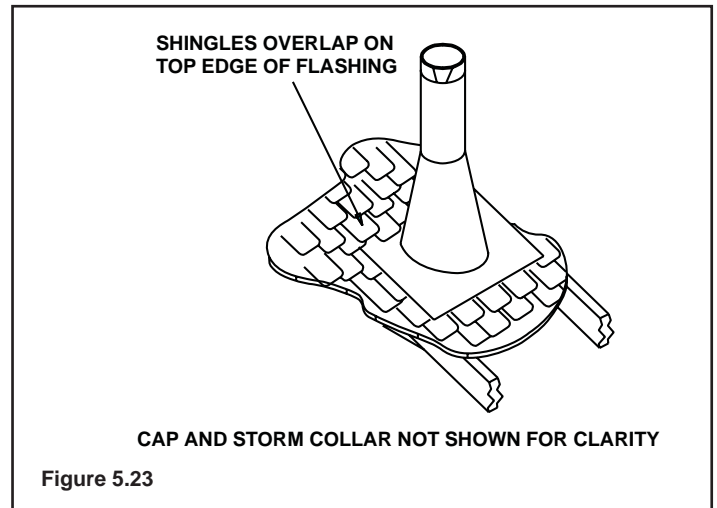

Step 7.

Continue to assemble pipe sections until the height of the flue (before adding the termination cap) meets the minimum local code requirements. Note that for steep roof pitches, the flue height must be increased. See Roof Pitch Table (**Figure 4.3**). In high wind conditions, nearby trees adjoining rooflines, steep pitched roofs, and other similar factors can result in poor draft, or down drafting. In these cases increasing the flue height or switching to the high wind termination cap may solve this problem.

Step 8.

Slip the storm collar over the pipe, and push it down to the top of the flashing (**Figure 5.24**). Use non-hardening sealant above and below the joint between the storm collar and the pipe.

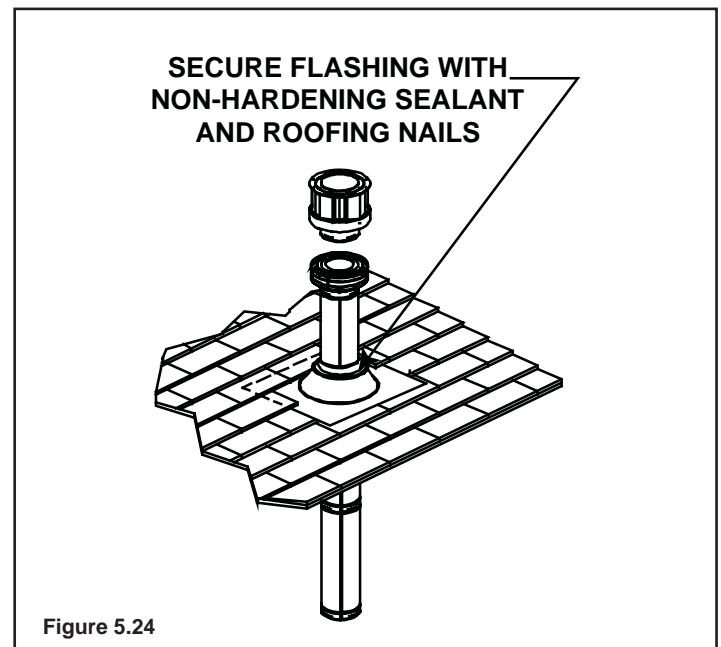

Step 9.

Twist-lock the flue cap and seal.

Note: For multi-story vertical installations, a ceiling firestop is required at the second floor, and any subsequent floors (Figure 5.25). The opening should be framed to 25.4cm x 25.4cm inside dimensions, in the same manner as shown in Figure 5.22.

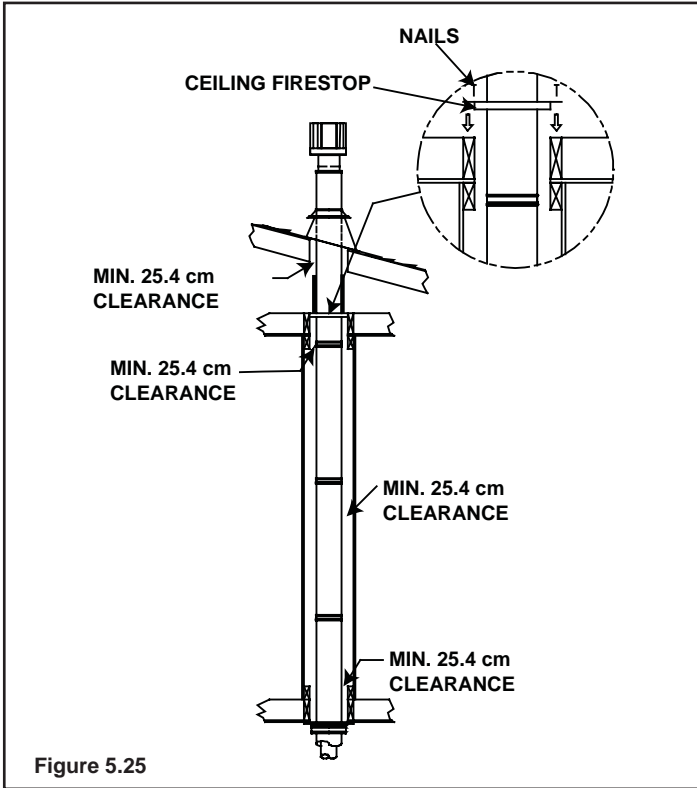

H. Vertical Flue Restrictor

If the fireplace installation requires a vertical flue off the top of the unit with no horizontal flue or elbows, the vertical flue restrictor must be added. Reinstall heat shield when completed. See Figure 4.25.

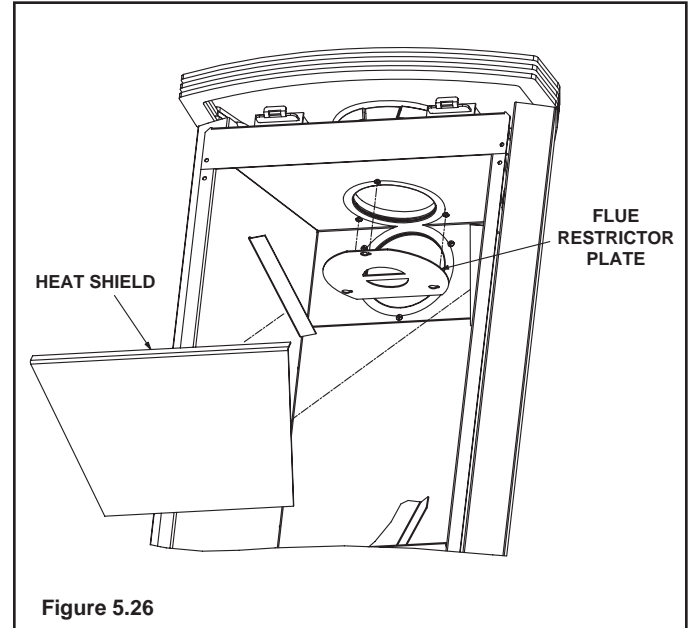

WARNING

Fire Risk.
Explosion Risk.

- Any occupied areas above the first floor, including closets and storage spaces, which the vertical flue passed through must be enclosed. The enclosure may be framed and sheetrocked with standard construction materials; however, refer to these installation instructions for the minimum allowable clearance between the outside of the flue pipe and the combustible surfaces of the enclosure. Do not fill any of the required air space with insulation.

6

Gas Information

A. Gas Pressure Requirements

Pressure requirements for VRTIKL-CE Stoves are shown in Table 1 below.

Two taps are provided on the right hand side of the gas control for a test gauge connection to measure the inlet and outlet pressures. See **Section 10: Maintaining and Servicing the Appliance.**

The stove and its individual shut-off valve must be disconnected from the gas supply piping system during any pressure testing of the system at test pressures in excess of 60 mbar.

If the stove must be isolated from the gas supply piping system by closing an individual shut-off valve, it must be of the handle-less type.

B. Gas Connection

Note: Have the gas supply line installed in accordance with local building codes by a qualified installer approved and/or licensed as required by the locality.

Note: Before the first firing of the stove, the gas supply line should be purged of any trapped air.

Note: Consult local building regulations to properly size the gas supply line leading to the (Rp 1/2 in.) hook-up at the unit.

Incoming gas line should be piped into the valve compartment and connected to the ISO 7-Rp 1/2 (BSP Rp 1/2) threaded gas inlet connection on the manual shutoff valve.

Leak test all gas line points and the gas control valve prior to and after starting the gas stove.

⚠ WARNING

Fire Risk

Explosion Risk

High pressure will damage valve.

- Disconnect gas supply piping **BEFORE** pressure testing gas line at test pressures above 60 mbar.
- Close the manual shutoff valve **BEFORE** pressure testing gas line at test pressures equal to or less than 60 mbar.

⚠ WARNING

CHECK FOR GAS LEAKS

Fire Risk

Explosion Risk

Asphyxiation Risk

- Check all fittings and connections.
- Do not use open flame.
- After the gas line installation is complete, all connections must be tightened and checked for leaks with a commercially available, non-corrosive leak check solution. Be sure to rinse off all leak check solution following testing.

Fittings and connections may have loosened during shipping and handling.

Table 1

	Natural Gas (G20)	Propane (G31)	Butane (G30)	Natural Gas (G25)
Inlet Pressure	20mbar	37 or 50mbar	30 or 50mbar	25mbar
Manifold Pressure	4-8.4mbar	15.7-25mbar	15.7-25mbar	4-8.4mbar
Gas Rate	.72 m ³ /h	.26 m ³ /h	.10 m ³ /h	.67 m ³ /h
Max.Input (NETCV)	6.9 kW	6.6 kW	5.8 kW	5.5 kW
Burner Injector	DMS 39	DMS 53	DMS 55	DMS 39
Pilot Injector	51	30	30	51

7

Electrical Information

A. Ignition System Wiring

- This gas stove is equipped with an electronic ignition system which operates on a 6 volt system.
- The batteries are located within the ignition module which is located behind the glass door assembly. A wiring diagram is shown in Figure 7.1.
- The battery pack requires four AA batteries (not included).

CAUTION

Battery polarity must be correct or module damage will occur.

WARNING



Shock Risk

- Replace damaged wire with type 105° C rated wire.
- Wire must have high temperature insulation.

CAUTION

Label all wires prior to disconnection when servicing controls. Wiring errors can cause improper and dangerous operation. Verify proper operation after servicing.

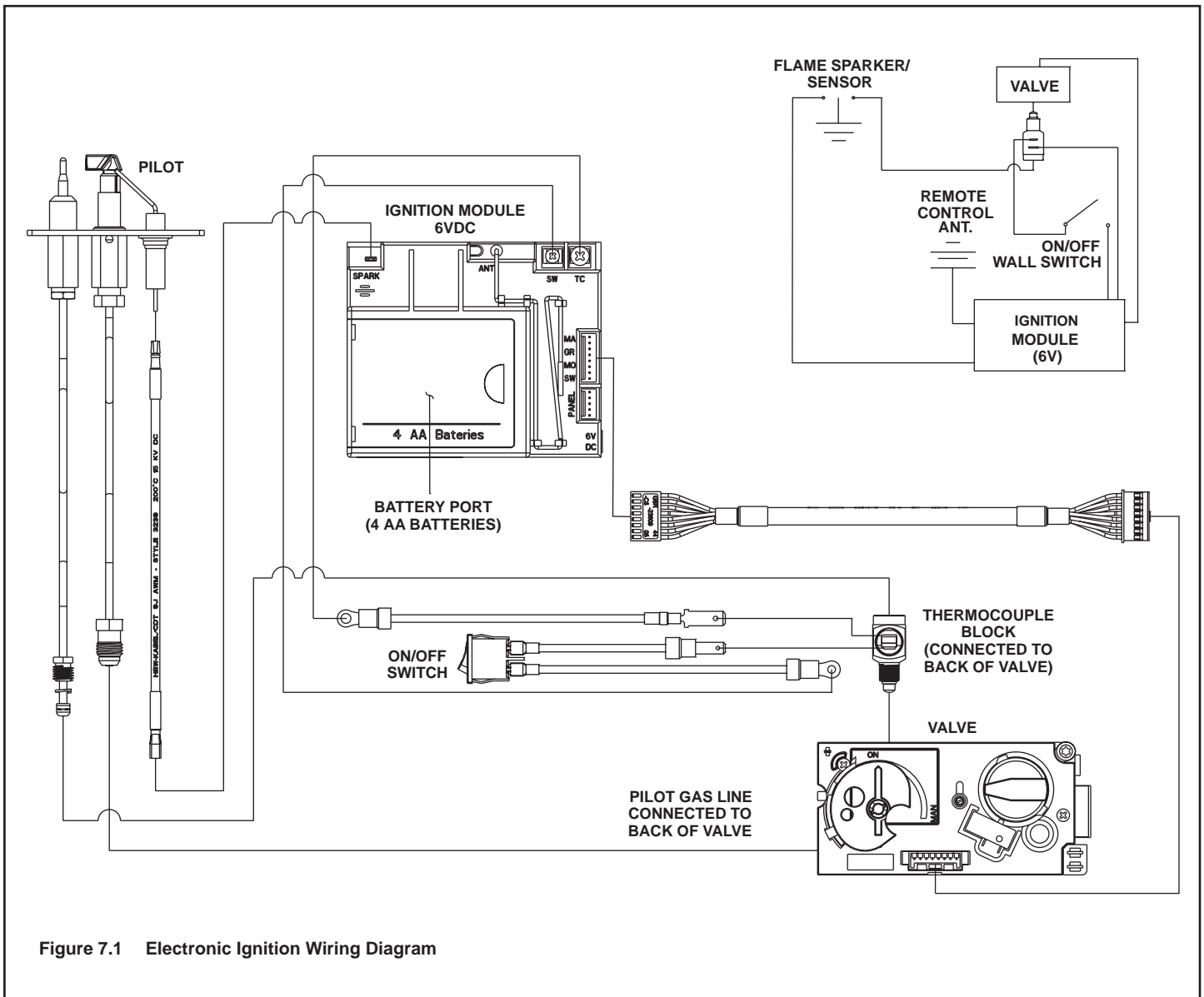

Figure 7.1 Electronic Ignition Wiring Diagram

8

Appliance Setup

A. Remove Shipping Materials

Remove shipping materials from inside or underneath the firebox.

The gas line is shipped inside back panel. To access the gas line remove the top plate from the gas stove. Remove and retain the two Allen head screws that hold the back panel in place. Replace panel when finished.

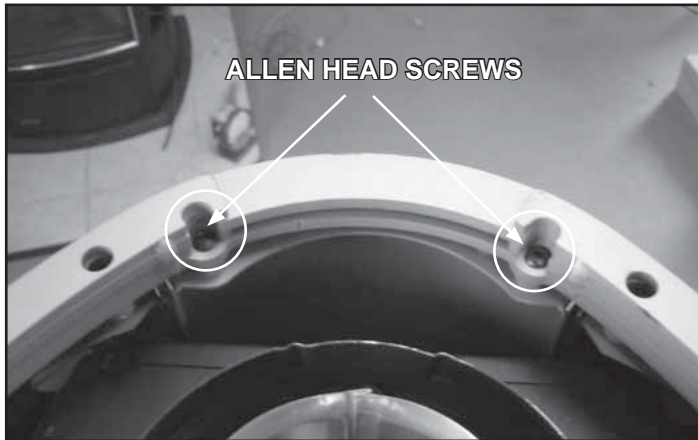

Figure 8.1

B. Unbolting Appliance from the Pallet

The gas stove is bolted and screwed to the pallet for shipping. Use a 1/2 in. socket to remove the bolt in center of bottom plate. Use a Phillips screwdriver to remove the two screws in the front of the bottom plate and the two screws holding the metal strap across the back of the gas stove. Refer to **Figure 8.2** for locations.

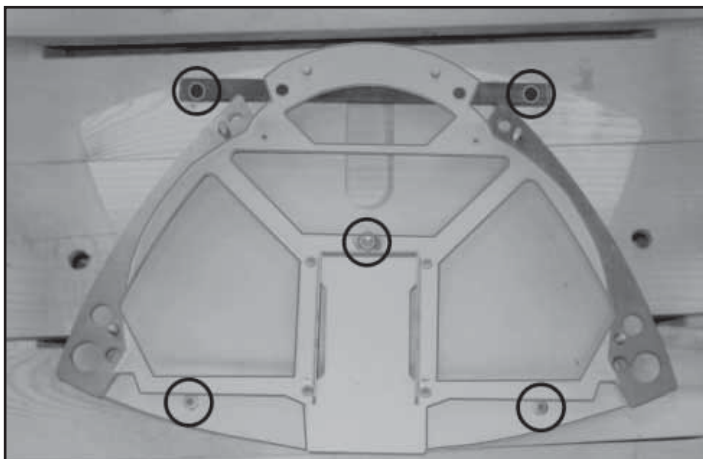

Figure 8.2

C. Leveling and Bolting Down the Appliance

SECURING THE GAS STOVE IS REQUIRED.

WARNING



Tipping Risk

- Install gas stove on a stable, level platform/floor strong enough to support gas stove without tipping.
- USE wood flooring, ceramic tile, brick hearth or high pressure laminate flooring applied directly over the sub-flooring material.

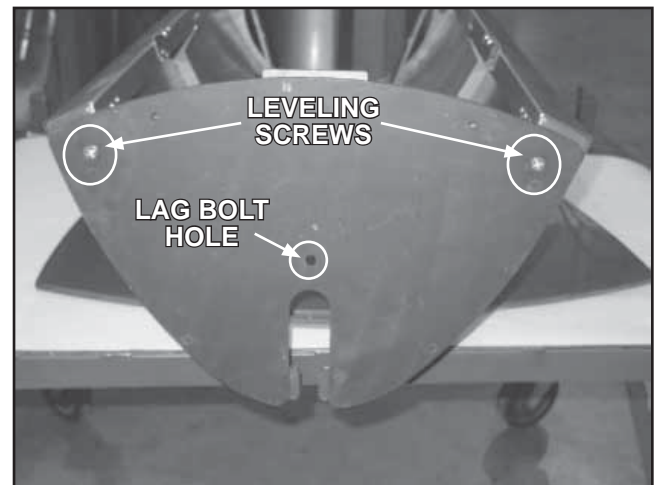

Figure 8.3

After unbolting the gas stove from the pallet, insert two 1/4 20 x 1-1/2 (or equivalent) counterscrews.

Using pliers, adjust the counterscrews to level the gas stove.

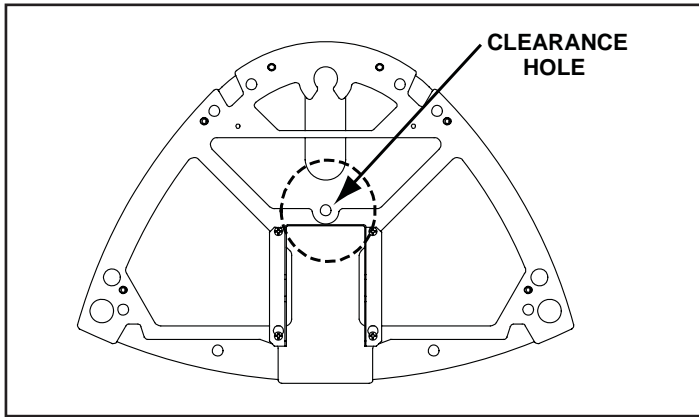

Figure 8.4

The manufacturer recommends securing the lag bolt from the component bag in the center hole in the bottom plate (clearance hole). This bolt will help to prevent tipping forward.

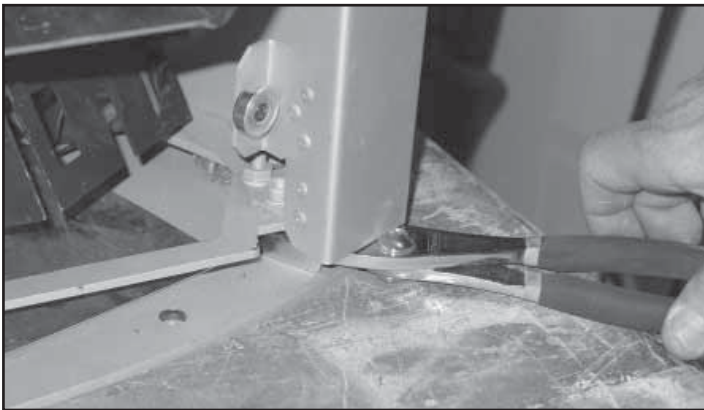

Figure 8.5

Using pliers, adjust the counter screws to level the gas stove.

D. Accessories

Install approved accessories per instructions included with accessories. Refer to **Section 12F** for appropriate accessories.

	<p>WARNING</p> <p>Shock or fire risk.</p>
	<p>Use ONLY optional accessories approved for this gas stove.</p> <ul style="list-style-type: none"> • Using non-listed accessories voids warranty. • Using non-listed accessories may result in a safety hazard. • Only Hearth & Home Technologies approved accessories may be used safely.

E. Top to Rear Flue Conversion

KIT CONTENTS: Top cover (without hole);
Back panel (with hole).

1. Remove the front door assembly by pulling bottom of front away from gas stove and lifting it off of the hooks on top of the gas stove. Set door aside.

ON TOP OF APPLIANCE:

2. Remove the top plate with hole and discard. (**Figure 8.6**)



Figure 8.6

3. Remove and retain the Allen head screws that hold the solid back panel in place (**Figure 8.8**). Remove and discard the solid back panel.

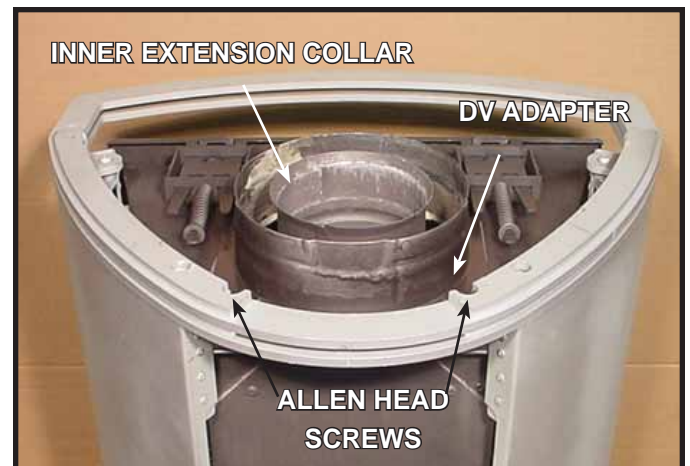

Figure 8.7

4. Remove the inner extension collar (Shown in **Figure 8.7**) and set aside.
5. Remove the four screws from the DV adapter collar (**Figure 8.7**). Set aside DV adapter collar and screws.

ON BACK OF APPLIANCE:

6. Remove the four screws from the cover plate on rear of gas stove. Set cover plate aside. Retain screws. (See **Figure 8.8**). Attach DV adapter collar in its place. Install the inner extension collar.



Figure 8.8

7. Install the cover plate with gasket to the top of gas stove with screws previously removed (**Figure 8.9**).



Figure 8.9

ON TOP OF APPLIANCE:

8. Install the new back panel (without hole) to the rear of gas stove. Replace the Allen head screws removed in Step 3 to hold the back panel in place.
9. Install the new top as shown in Figure 8.10.



Figure 8.10

F. Installing the Baffle

The baffle is shipped wrapped, inside the firebox. Install the baffle with the embedded "T" side up, place it on top of the brackets on the inside of the firebox, ensuring back edge of baffle makes contact with the back of the firebox.



Figure 8.11

G. Positioning the Logs

While still breakable, the logs do not become fragile until after the gas stove is burned and they have cured. After curing, any handling must be done with care as breakage can easily occur.

PLEASE NOTE: Logs have been designed to work specifically with the burner of this gas stove. Exact placement will ensure proper operation of your gas stove.



Figure 8.12



Figure 8.13

Place log #1 into the cradle in the burner. Lean the log back towards right corner of firebox.



Figure 8.14

Locate log #2 over the pin in log #1 and into notch in log #1. Lean the log back toward the left corner of the firebox.

H. Placing Mineral Wool



WARNING



Explosion Risk.

- Follow ember placement instructions in manual.
- Do NOT place embers directly over burner ports.
- Replace ember material annually.

Improperly placed embers interferes with proper burner operation.

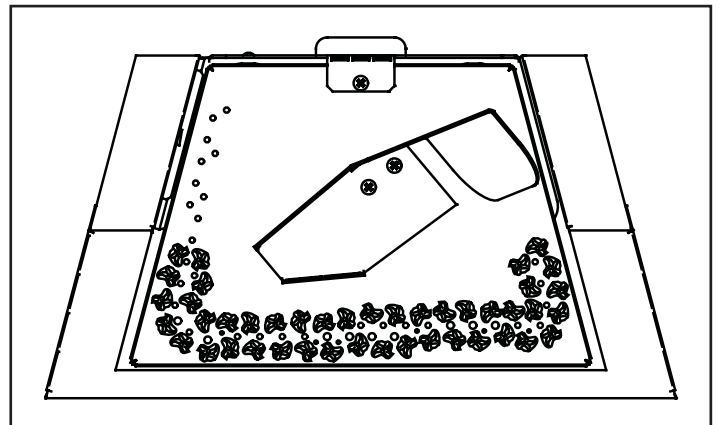

Figure 8.17

Apply 1.5 cm size pieces sparingly along ports as shown in Figure 8.17. Do not block ports.

I. Front Door Glass Assembly Installation

Remove the front door assembly by pulling bottom of front away from gas stove and lifting it off of the hooks on top of the gas stove (see **Figure 8.15**).

Refer to Figure 8.16: Position the four flat 6 mm spacer washers on the front door so that the four mounting screws pass through them. Position the glass over the front door.

Install the four protective barrels into the glass and the four nylon washers on top of the glass.

From inside the door front, pass the screws through to the outside and thread on the caps until tight.

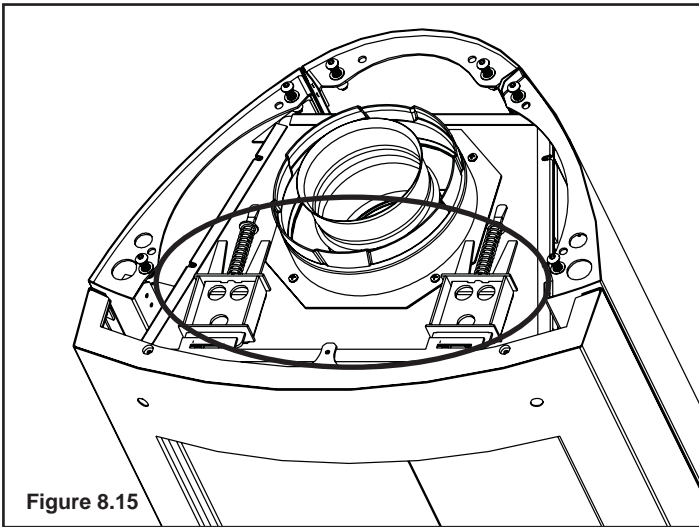

Figure 8.15

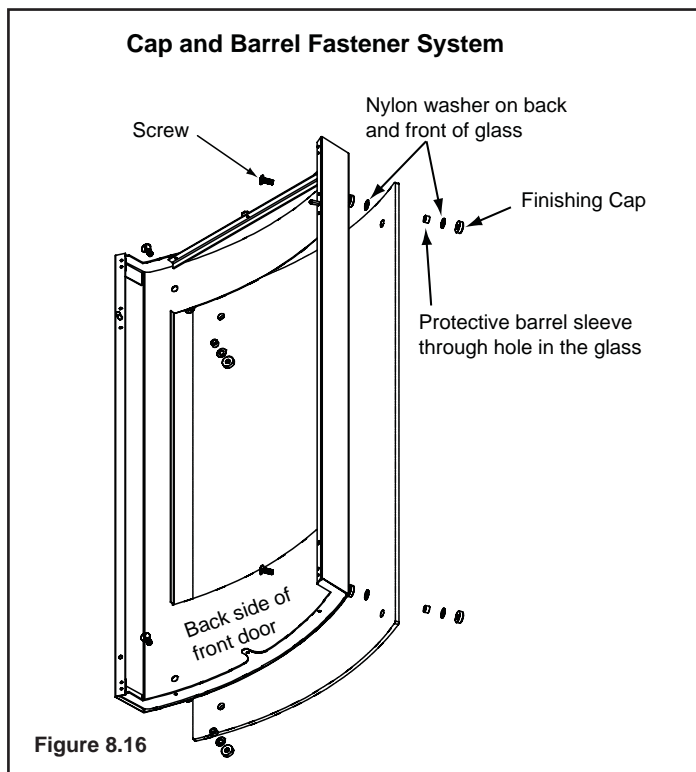

Figure 8.16

J. Inner Glass Door Assembly Replacement

Turn the gas stove OFF and let it cool down before replacing the inner glass door assembly.

With the front door assembly removed from the gas stove, remove the inner glass door assembly by disengaging the spring-loaded latches at the bottom of the gas stove and lifting off of the two spring-loaded latches at the top of the gas stove.

Replace with a new inner glass door assembly.

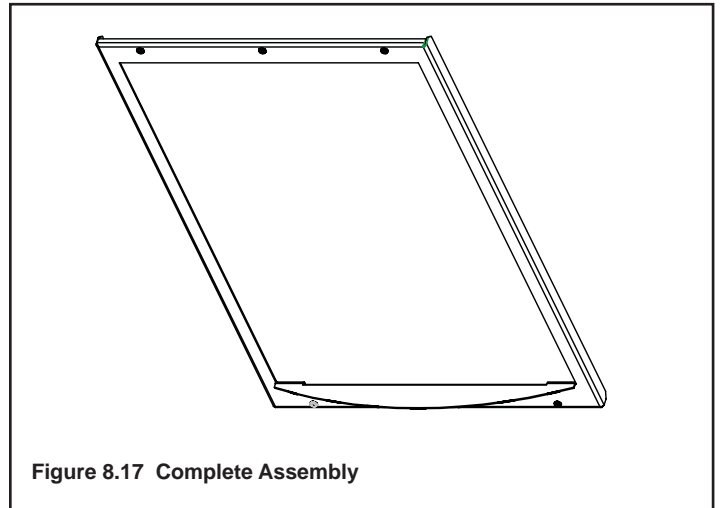

Figure 8.17 Complete Assembly

CAUTION



Handle glass assembly with care.

- Inspect the gasket to ensure it is undamaged.
- Inspect the glass for cracks, chips or scratches.
- Do NOT strike, slam or scratch glass.
- Do NOT operate gas stove with glass door removed, cracked, broken or scratched.
- Replace glass assembly as a complete assembly.



9



Operating Instructions

A. Before Lighting Appliance

Read this entire manual prior to using the gas stove. Failure to follow the instructions may result in property damage, bodily injury, or even death.

- Remove all shipping materials from inside and/or underneath the firebox.
- Review proper placement of logs, mineral wool.
- Check the wiring.
- Check the baffle adjustment.
- Ensure that there are no gas leaks.
- Ensure that the glass is sealed and in the proper position.
- Ensure that the flow of combustion and ventilation air is not obstructed (front grilles and flue caps).

 WARNING	
	Glass door must be in place when gas stove is operating.
	Risk of: <ul style="list-style-type: none">• Combustion Fumes• Fire
	Do NOT operate gas stove with glass door removed.
	<ul style="list-style-type: none">• Open viewing glass for servicing only.• Glass door MUST be in place and sealed before operating gas stove.• Only use glass door certified for use with gas stove.• Glass replacement should be done by qualified technician.

 WARNING	
	HOT SURFACES! Glass and other surfaces are hot during operation AND cool down.
	Hot glass will cause burns. <ul style="list-style-type: none">• DO NOT touch glass until it is cooled• NEVER allow children to touch glass• Keep children away
	<ul style="list-style-type: none">• CAREFULLY SUPERVISE children in same room as fireplace.• Alert children and adults to hazards of high temperatures.
	High temperatures may ignite clothing or other flammable materials. <ul style="list-style-type: none">• Keep clothing, furniture, draperies and other flammable materials away.
	<hr/> <i>This appliance has been supplied with an integral barrier to prevent direct contact with the fixed glass panel. DO NOT operate the appliance with the barrier removed.</i>
	Contact your dealer if the barrier is not present or help is needed to properly install one.

 WARNING	
	Improper installation, adjustment, alteration, service or maintenance can cause injury or property damage. Refer to the owner's information manual provided with this gas stove. For assistance or additional information consult a qualified installer, service agency or the gas supplier.

 WARNING	
	Do NOT use this gas stove if any part has been under water. Immediately call a qualified service technician to inspect the gas stove and to replace any part of the control system and any gas control which has been under water.

B. Lighting the Appliance

Electronic Ignition

FOR YOUR SAFETY READ BEFORE LIGHTING

WARNING: If you do not follow these instructions exactly, a fire or explosion may result causing property damage, personal injury or loss of life.

- A.** This gas stove is equipped with an electronic pilot ignition device which automatically lights the burner. Do not try to light the burner by hand.
- B. BEFORE LIGHTING**, smell all around the gas stove area for gas. Be sure to smell next to the floor because some gas is heavier than air and will settle on the floor.
- WHAT TO DO IF YOU SMELL GAS**
- Do not try to light any gas stove.
 - Do not touch any electric switch;
- do not use any phone in your building.
- Immediately call your gas supplier from a neighbor's phone. Follow the gas supplier's instructions.
 - If you cannot reach your gas supplier, call the fire department.
- C.** Do not use this gas stove if any part has been under water. Immediately call a qualified service technician to inspect the gas stove and to replace any part of the control system and any gas control which has been under water.

WARNING:

DO NOT CONNECT 240 VAC TO THE CONTROL VALVE.

Improper installation, adjustment, alteration, service or maintenance can cause injury or property damage. Refer to the owner's information manual provided with this gas stove.

This gas stove needs fresh air for safe operation and must be installed so there are provisions for adequate combustion and ventilation air.

If not installed, operated, and maintained in accordance with the manufacturer's instructions, this product could expose you to substances in fuel or fuel combustion.

Keep burner and control compartment clean. See installation and operating instructions accompanying gas stove.

CAUTION:

Hot while in operation. Do not touch. Keep children, clothing, furniture, gasoline and other liquids having flammable vapors away.

Do not operate the gas stove with panel(s) removed, cracked or broken. Replacement of the panel(s) should be done by a licensed or qualified service person.



NOT FOR USE WITH SOLID FUEL

For use with natural, propane and butane gases.

LIGHTING INSTRUCTIONS

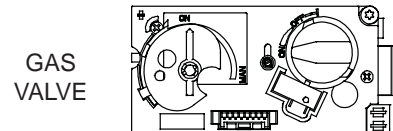
1. This gas stove is equipped with an ignition device which automatically lights the burner. Do not try to light the burner by hand.



2. Wait five (5) minutes to clear out any gas. Then smell for gas, including near the floor. If you smell gas, STOP! Follow "B" in the Safety Information located on the left side of this label. If you don't smell gas, go to next step.
3. To light the burner, simultaneously press the star  and up  arrow buttons on the remote control until a short acoustic signal confirms the start sequence has begun.
4. If the gas stove will not operate, check the batteries then follow the instructions "To Turn Off Gas to Appliance" and call your service technician or gas supplier.

TO TURN OFF GAS TO APPLIANCE

1. Push the 'OFF' button on remote.
2. Remove batteries from receiver.



C. After Appliance is Lit

Initial Break-in Procedure

When you light your gas stove, you may notice that it produces heat which does have an associated odor or smell. If you feel this odor is excessive it may require the initial three to four hour continuous burn on high followed by a second burn up to 12 hours to fully drive off any odor from paint and lubricants used in the manufacturing process. Condensation on the inside of the glass is normal.



NOTE: The gas stove should be run three to four hours on the initial start-up. Turn it off and let it cool completely. Remove and clean the glass. Replace the glass and run the gas stove for an additional 12 hours. This will help to cure the products used in the paint and logs.

During this break-in period it is recommended that some windows in the house be opened for air circulation. This will help avoid setting off smoke detectors, and help eliminate any odors associated with the gas stove's initial burning.

	 WARNING
	<p>Fire Risk. High Temperatures.</p> <p>Keep combustible household items away from gas stove. Do NOT obstruct combustion and ventilation air.</p> <ul style="list-style-type: none"> Do NOT place combustible items on top of or in front of gas stove. Keep furniture, draperies away from gas stove.

CAUTION
<ul style="list-style-type: none"> Prevent accidental gas stove operation when not attended. Unplug or remove batteries from remote control if absent or if gas stove will not be used for an extended period of time. Property damage possible from elevated temperatures.

CAUTION
<p>Smoke and odors released during initial operation.</p> <ul style="list-style-type: none"> Open windows for air circulation. Leave room during initial operation. Smoke may set off smoke detectors. <p>Smoke and odors may be irritating to sensitive individuals.</p>

 WARNING		
<td style="text-align: center;"></td> <td> <p>Fire Hazard. Keep combustible materials, gasoline and other flammable vapors and liquids clear of gas stove.</p> <ul style="list-style-type: none"> Do NOT store flammable materials in the gas stove's vicinity. Do NOT use gasoline, lantern fuel, kerosene, charcoal lighter fluid or similar liquids in this gas stove. Combustible materials may ignite. </td>		<p>Fire Hazard. Keep combustible materials, gasoline and other flammable vapors and liquids clear of gas stove.</p> <ul style="list-style-type: none"> Do NOT store flammable materials in the gas stove's vicinity. Do NOT use gasoline, lantern fuel, kerosene, charcoal lighter fluid or similar liquids in this gas stove. Combustible materials may ignite.

D. Frequently Asked Questions

ISSUE	SOLUTIONS
Condensation on the glass	This is a result of gas combustion and temperature variations. As the gas stove warms, this condensation will disappear.
Blue flames	This is a result of normal operation and the flames will begin to yellow as the gas stove is allowed to burn for 20 to 40 minutes.
Odor from gas stove	When first operated, this gas stove may release an odor for the first several hours. This is caused by the curing of the paint and the burning off of any oils remaining from manufacturing.
Film on the glass	This is a normal result of the curing process of the paint and logs. Glass should be cleaned within 3 to 4 hours of initial burning to remove deposits left by oils from the manufacturing process. A non-abrasive cleaner such as gas stove cleaner may be necessary. See your dealer. Ensure glass has cooled before cleaning.
Metallic noise	Noise is caused by metal expanding and contracting as it heats up and cools down, similar to the sound produced by a furnace or heating duct. This noise does not affect the operation or longevity of the gas stove.

10

Maintaining and Servicing Appliance

Although the frequency of your gas stove servicing and maintenance will depend on use and the type of installation, a qualified service technician should perform an gas stove check-up at the beginning of each heating season.



WARNING

Risk of injury or property damage.

Before servicing:

- Turn off gas.
- Turn off electricity to gas stove.
- Ensure gas stove is completely cooled.

After servicing:

- Replace any screen or barrier that was removed.
- Reseal and reinstall any venting removed for servicing.



WARNING

Annual inspection by qualified technician recommended.

Check:

- Condition of glass, glass assembly and glass seal.
- Obstructions of combustion and ventilation air.
- Obstructions of termination cap.
- Burner ignition and operation.
- Burner air shutter adjustment
- Gas connections and fittings.

Clean:

- Glass
- Air passageways, grilles, control compartment
- Burner, burner ports

Risk of:

- Fire
- Delayed ignition or explosion
- Exposure to combustion fumes
- Odors



WARNING

Inspect external flue cap regularly.

- Ensure no debris blocks cap.
- Combustible materials blocking cap may ignite.
- Restricted air flow affects burner operation.



CAUTION

Handle glass assembly with care.

NOTE: Clean glass after initial 3-4 hours operation. **Longer operation without cleaning glass may cause a permanent white film on glass.**

When cleaning glass door:

- Avoid striking, scratching or slamming glass.
- Do NOT use abrasive cleaners.
- Use a hard water deposit glass cleaner on white film.
- Do NOT clean glass when hot.
- Turn off gas stove after 3-4 hours of operation and ALLOW TO COOL.
- Remove and clean glass assembly.
- Replace glass assembly and operate gas stove for additional 12 hours.

Refer to maintenance instructions.

A. Maintenance Tasks

Inspect	Maintenance Tasks
Doors	1. Inspect for scratches, dents or other damage and repair as necessary.
	2. Verify no obstructions to air flow.
	3. Verify maintenance of proper clearance to combustible household objects.
Gasket Seal, Glass Assembly and Glass	1. Inspect gasket seal and its condition.
	2. Inspect glass for scratches and nicks that can lead to breakage when exposed to heat.
	3. Confirm there is no damage to glass or glass frame, Replace as necessary.
	4. Verify that latches engage properly and glass attachment components are intact and operating properly. Replace as necessary.
	5. Clean glass. Replace glass assembly if severely coated with silicate deposits that cannot be removed.
Valve Compartment and Firebox Top	1. Vacuum and wipe out dust, cobwebs, debris or pet hair. Use caution when cleaning these areas. Screw tips that have penetrated the sheet metal are sharp and should be avoided.
	2. Remove any foreign objects.
	3. Verify unobstructed air circulation.
Logs	1. Inspect for broken, damaged, or missing logs. Replace as necessary.
	2. Verify correct log placement and no flame impingement causing sooting. Correct as necessary.
Firebox	1. Inspect for paint condition, warpage, corrosion or perforation. Sand and repaint as necessary.
	2. Replace gas stove if firebox has been perforated.
Burner Ignition and Operation	1. Verify burner is properly secured and aligned with pilot or igniter.
	2. Clean off burner top, inspect for plugged ports, corrosion or deterioration. Replace burner if necessary.
	3. Replace ember material with new 1.5 cm pieces. Do not block ports or obstruct lighting paths.
	4. Check for smooth lighting and ignition carryover to all ports. Verify there is no ignition delay.
	5. Inspect for lifting and other flame problems.
	6. Inspect orifice for soot, dirt or corrosion.
	7. Verify manifold and inlet pressures. Adjust regulator as required.
	8. Inspect pilot flame strength. Clean or replace orifice as necessary.
	9. Inspect thermocouple sensor rod for soot, corrosion and deterioration. Clean with emery cloth or replace as required.
	10. Verify millivolt output. Replace as necessary.
Flueing	1. Inspect flueing for blockage or obstruction such as bird nests, leaves, etc.
	2. Confirm that termination cap remains clear and unobstructed by plants, etc.
	3. Verify that termination cap clearance to subsequent construction (building additions, decks, fences or sheds) has been maintained.
	4. Inspect for corrosion or separation.
	5. Verify weather stripping, sealing and flashing remains intact.
Remote Control	1. Verify operation of remote.
	2. Replace batteries in remote transmitters and battery-powered receivers.

11

Troubleshooting

With proper installation, operation and maintenance your gas stove will provide years of trouble-free service. If you do experience a problem, this troubleshooting guide will assist a qualified service person in the diagnosis of a problem and the corrective action to be taken. This troubleshooting guide can only be used by a qualified service technician.

Electronic Ignition System

Symptom		Possible Causes	Corrective Actions
1.	No transmission, motor does not turn.	A. Receiver must learn new code.	Press and hold the receiver's reset button until you hear 2 acoustic signals. After the second longer acoustic signal, release the reset button and within the subsequent 20 seconds, press the down arrow on the remote handset until you hear an additional long acoustic signal confirming the new code is set.
2.	No ignition. No tone.	A. Receiver	Replace receiver and reprogram code.
3.	No ignition; one 5 seconds continuous tone (7 shorts beeps might be heard prior to the 5 seconds tone).	A. ON/OFF switch is in OFF position.	Push switch to ON position.
		B. Loose wire.	Secure wire.
		C. Receiver.	Replace receiver and reprogram.
		D. Bent pins on 8 wire connector.	Straighten pins on 8 wire connector.
		E. Valve.	Replace valve.
4.	No pilot flame and control continues to spark.	A. Air in the pilot supply line.	Purge the line or start ignition several times.
		B. Thermocouple circuit wired incorrectly.	Check polarity of the thermocouple wires.
		C. No spark at pilot burner.	Check spark gap, check wiring connection. Check for spark in location along cable.
		D. Valve.	Replace valve. Do not over tighten.
		E. Over tightened thermocouple interrupter.	Replace valve and thermocouple interrupter.
		F. Receiver.	Replace receiver and reprogram code.
5.	Pilot is lit and control continues to spark. Valve shuts off after 10...30 seconds. Valve operates manually.	A. Receiver.	Replace receiver and reprogram code.
6.	Pilot is lit, sparking stops if a flame is present. Valve shuts off after 10...60 seconds. Valve does not work manually.	A. Thermocouple.	Replace thermocouple.
		B. Low inlet pressure to valve.	Confirm sufficient inlet pressure to the valve. Adjust or replace inlet regulator if necessary.
		C. Valve.	Replace valve. Do not tighten the thermocouple interrupter.
7.	3 short beeps while the motor turns.	A. Batteries are low.	Replace batteries - quality alkaline recommended. WARNING: Creating an electrical short between the batteries/battery box and metal parts of the appliance may render the receiver inoperable.
8.	Pilot flame lights but there is no main gas flow.	A. Manual override knob (if equipped) is in MAN position.	Turn Manual override knob to ON position.
		B. Valve turned down to pilot flow.	Turn flame to high fire by pressing up button on remote handset.
		C. Low inlet pressure to valve.	Confirm sufficient inlet pressure to the valve. Adjust or replace inlet regulator if necessary.
		D. Valve.	Replace valve.
9.	Pilot sparks, but pilot will not light.	A. Correct gas supply.	Verify that incoming gas line ball valve is "open". Verify that inlet pressure reading is within acceptable limits, inlet pressure must not exceed 50 mbar.
		B. Ignitor gap is too large.	Verify that spark gap from ignitor to pilot hood is .43 cm.
		C. Module is not grounded.	Verify module is securely grounded to metal chassis of stove.

12

Reference Materials

A. Appliance Dimension Diagram

Dimensions are actual gas stove dimensions. Use for reference only. For clearances to combustibles refer to Section 3.

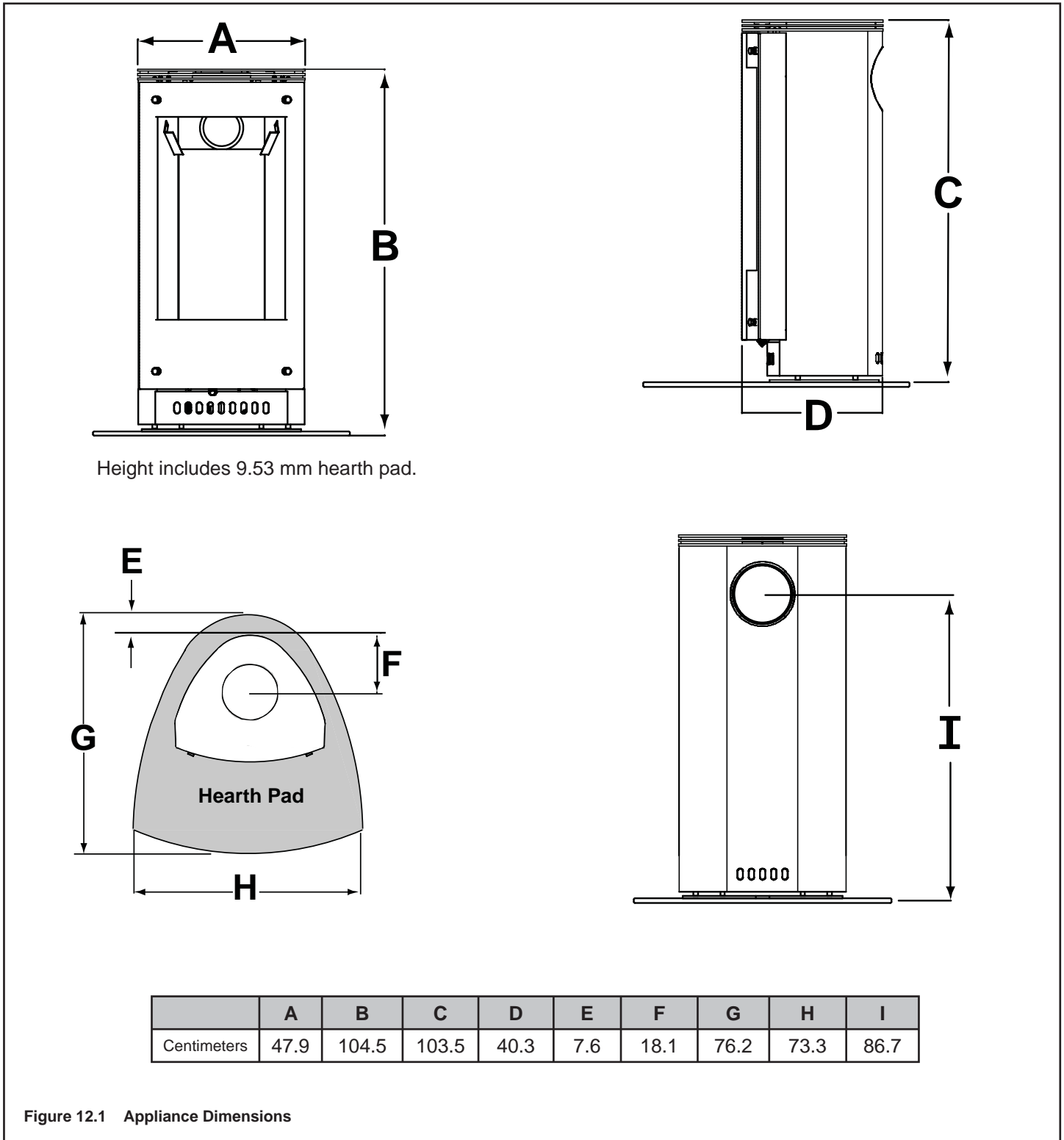

Figure 12.1 Appliance Dimensions

B. Appliance Dimension with Stone Surround Diagram

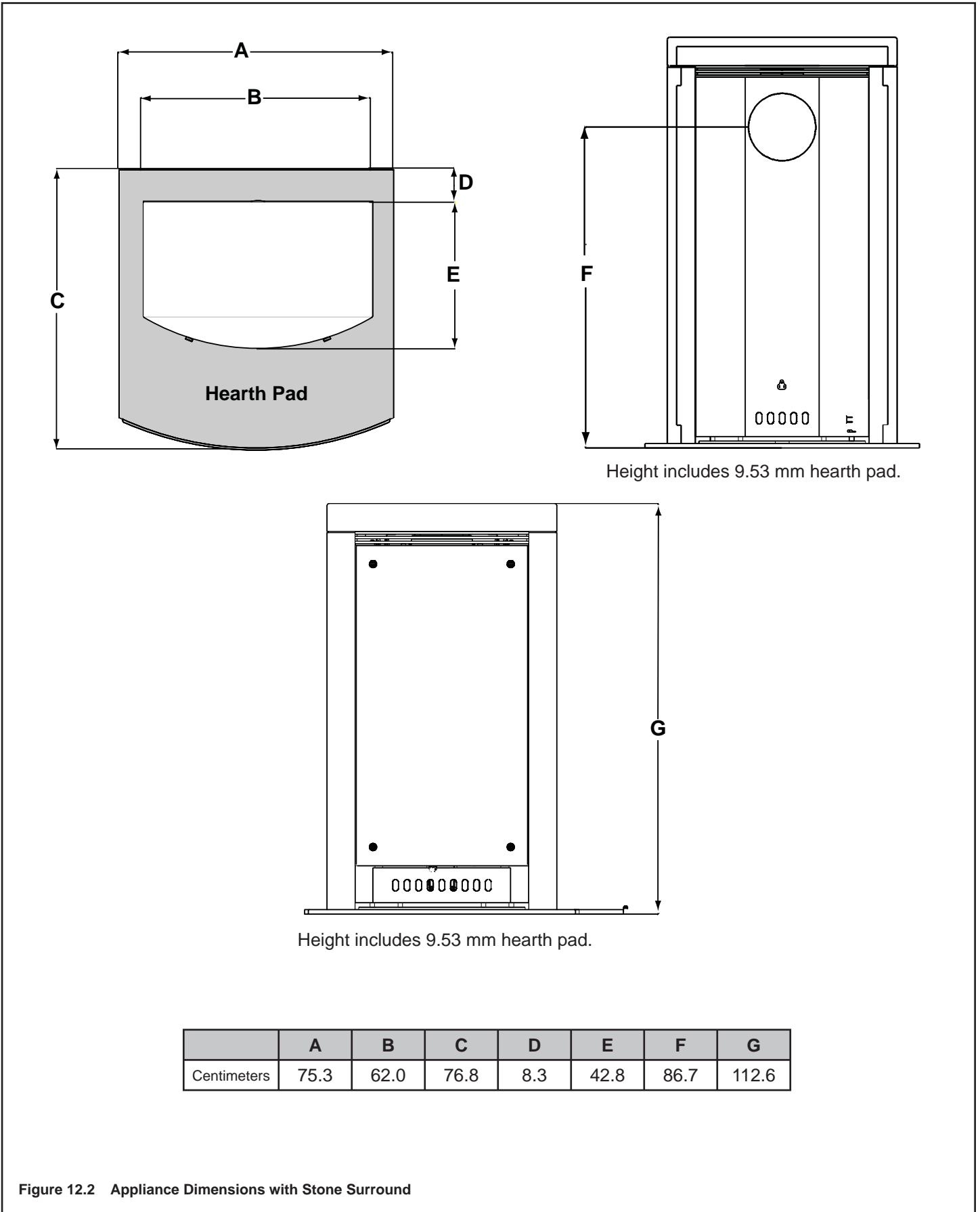
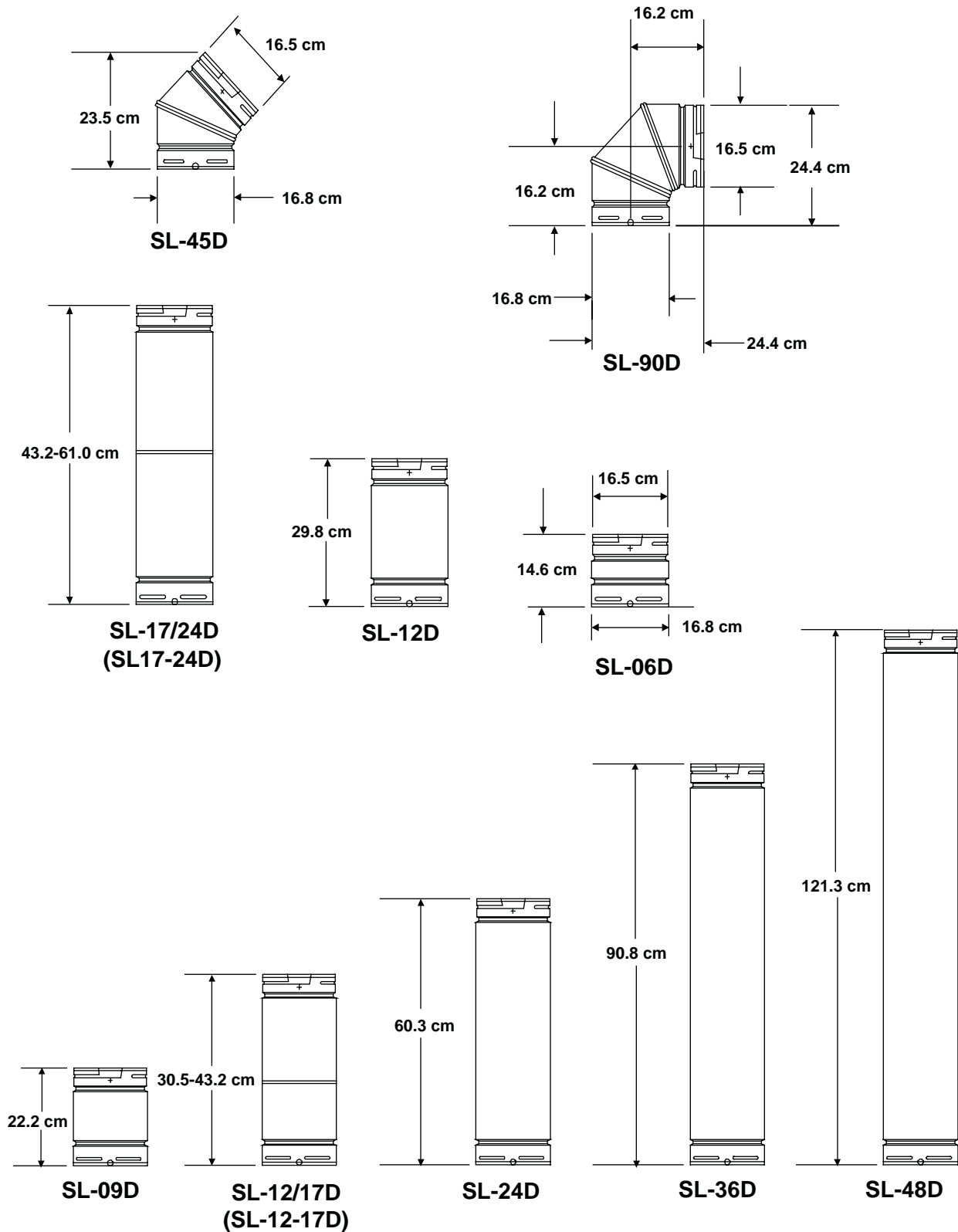

Figure 12.2 Appliance Dimensions with Stone Surround

C. Flue Components Diagram



SL D-Series Balance Flue Component Specifications 10.2 cm inner pipe, 16.8 cm outer pipe.

Figure 12.3

D. Flue Components List

COMPONENTS	
Ceiling Support / Wall Thimble, Black	656-230
Cathedral Ceiling Support, Black	941
15 cm Pipe Length, Black	908B
22 cm Pipe Length, Black	907B
31 cm Pipe Length, Black	906B
60 cm Pipe Length, Black	904B
91 cm Pipe Length, Black	903B
121 cm Pipe Length, Black	902B
28 - 37 cm Pipe Length, Black	911B
31 - 43 cm Pipe, Adjustable, Black	912B
45 degree Elbow, Black	945B
90 degree Elbow, Black	990B
15 cm Pipe	SL-06D
22 cm Pipe	SL-09D
31 cm Pipe	SL-12D
60 cm Pipe	SL-24D
91 cm Pipe	SL-36D
121 cm Pipe	SL-48D
45 degree Elbow	SL-45D
90 degree Elbow	SL-90D
0/12 - 6/12 Roof Flashing	SL-F6D
7/12 - 12/12 Roof Flashing	SL-F12D
Storm Collar	SL-SCD
Ceiling Firestop	SL-FCD
Wall Firestop	SL-FWD
Pipe Support Strap	SL-PSD
Decorative Radius Cover	DRC-RADIUS
HTI Wall Thimble	HTI-DV-WT
TERMINATION KITS	
Trapezoid Termination Kit 19.7 cm - 28 cm, 2 Firestops	SLK-01TRD
Vertical Termination Cap - High Wind	SLK-991DA

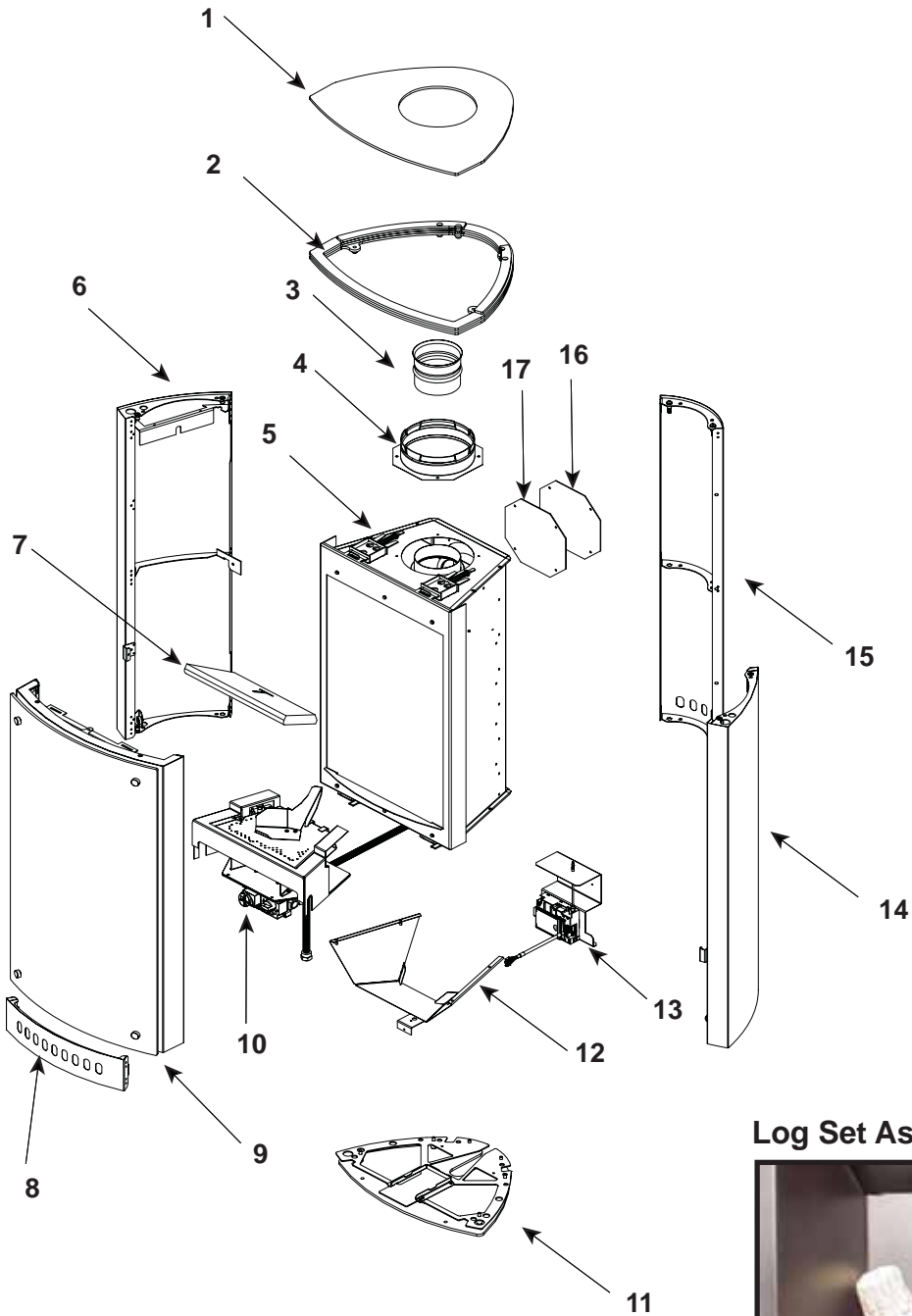

Log Set Assembly



Part number list on following page.

IMPORTANT THIS IS DATED INFORMATION: When requesting service or replacement parts for your appliance please provide model number and serial number. All parts listed in this manual may be ordered from an authorized dealer.

ITEM	DESCRIPTION	SERIAL #	PART NUMBER
	Log Set Assembly		7031-033
1	Removable Top Assembly		7031-017
2	Grill Assembly		7031-013
3	Adaptor 4 inch flue collar		200-2470
4	DV Adaptor		7000-162
5	Firebox Assembly		2123-004
	Glass Frame Assembly	Pre Sept 2007	7031-015
		Post Sept 2007	2123-005
	Latch Assembly Lower	Pre Sept 2007	7031-041
		Post Sept 2007	386-122A
	Latch Assembly Upper		7003-006
6	Side Assembly Left		7031-024
7	Exhaust Baffle		7031-219
8	Access Door Assembly		7031-023
9	Front Door Assembly	Bronze	2123-028
		Green	2123-029
		Gray	2123-016
10	Firebox Bottom Assembly N		2123-002
	Firebox Bottom Assembly P/B		2123-003
11	Bottom Plate Assembly		2123-015
	Blower Bracket		7031-194
12	Air Deflector		7031-140
13	Control Assembly		7031-059
	Control Module		2098-142
	Block Control Wire		2098-148
	Control Cable		2098-143
14	Side Assembly Right		7031-020
15	Back Panel Assembly		7031-021
16	Cover Plate Gasket		7010-160
17	Cover Plate		7010-159
	Flue Restrictor		7031-192
	Touch Up Paint (Pewter)		TUPP-12
	Top Vent Conversion Kit		PAL-TR
	Conversion Kit (N to P/B)		N2PB-VRT-CE
	Conversion Kit (P/B to N)		PB2N-VRT-CE
	Conversion Kit (P to B or B to P)		P2B/B2P-VRT-CE
	Pilot Orifice N		2098-518
	Pilot Orifice P		2098-512

Additional service part numbers appear on following page.

Valve Assembly

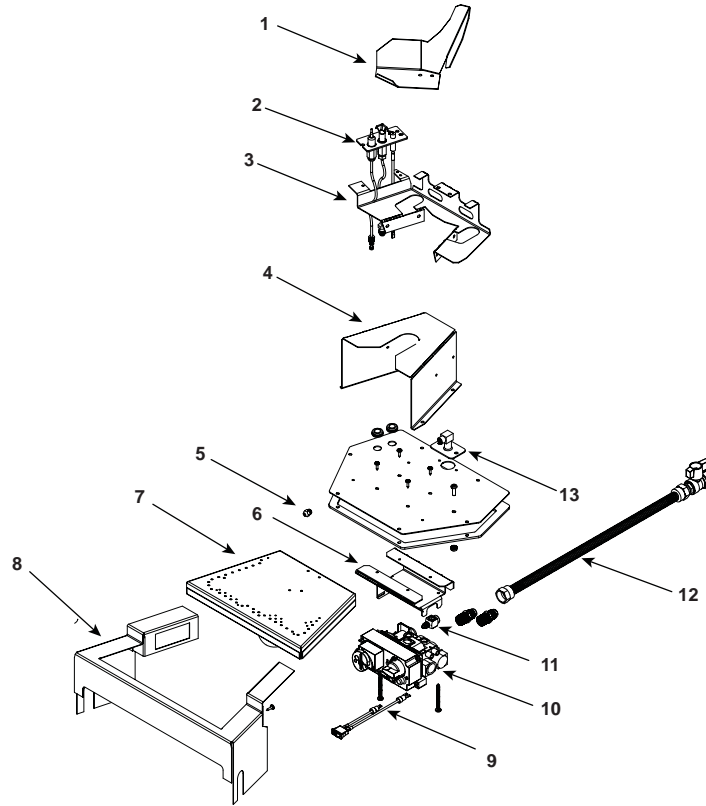

IMPORTANT THIS IS DATED INFORMATION: When requesting service or replacement parts for your appliance please provide model number and serial number. All parts listed in this manual may be ordered from an authorized dealer.

ITEM	DESCRIPTION	SERIAL #	PART NUMBER
1	Log Bracket		7031-282
2	Pilot Assembly N		2098-050
	Pilot Assembly P/B		2098-051
3	Pilot Bracket		2123-140
4	Burner Support		7031-279
5	Orifice N (#39C)		582-839
	Orifice P (#53C)		582-853
	Orifice B (#55C)		582-855
6	Valve Bracket	Pre Sept 2007	7031-278
		Post Sept 2007	2111-186
7	Burner N		7031-056
	Burner P/B		7031-057
8	Burner Shelf		2123-126
9	Switch Assembly, Maxitrol		2098-145
10	Valve N		2098-130
	Valve P/B		2098-131
11	Thermocouple Block		2098-146
12	Flex Ball Valve Assembly		2098-302A
13	Flex Gas Connector		383-302A

Additional service part numbers appear on following page.

F. Warranty Policy

HEAT & GLO LIMITED 10 YEAR WARRANTY



In order to presumptively establish the dates to which your HEAT & GLO Limited Warranty runs, you must mail the completed warranty card to HEAT & GLO, 20802 Kensington Boulevard, Lakeville, MN 55044, USA, within 60 days of the date of the stove installation. If you fail to do so, you may be required to prove the date of installation before warranty work can be performed.

The warranty exclusions and limitations of liability are effective upon installation of the stove.

Subject to the conditions set forth herein, HEAT & GLO, a brand of Hearth & Home Technologies, Inc. ("HEAT & GLO") extends the following warranty with respect to HEAT & GLO.

If HEAT & GLO is reasonably satisfied that any part or portion of the stove covered by this Limited Warranty is defective in material or workmanship under normal use and service as described in the User's Manual, HEAT & GLO will take the following actions:

1. If the defect is reported during the first year from the date of installation (stainless steel burners and fiber logs are covered for 3 years), HEAT & GLO will replace or repair the defective components at its sole expense. The decision whether to replace a component shall be made at HEAT & GLO's sole discretion. This Limited Warranty does not cover components broken during shipping, misuse or careless handling. HEAT & GLO shall not be responsible for any indirect, incidental, or consequential damages or for any costs other than those incurred by HEAT & GLO to repair or replace the defective component. If components (including venting) other than factory approved components are used, all warranty and liability on the stove is voided. Defects reported after the first year will not be covered by warranty unless they fall within the purview of paragraph 2 or 3 below.
2. If the following defects are reported during the second year after the date of installation, HEAT & GLO will supply replacement parts at the current wholesale price: defective electrical or manual components, optional components or accessories, and glass panels (not including glass panels broken during misuse or careless handling). HEAT & GLO shall not be responsible for any labor, transportation or other costs. Furthermore, it shall not be liable for any indirect, incidental or consequential damages.
3. HEAT & GLO will replace or repair a defective firebox or heat exchanger, at any time during the 10 years from the date of installation. The decision whether to replace the defective component shall be made at HEAT & GLO's sole discretion. HEAT & GLO shall not be responsible for any indirect, incidental or consequential damages or for any costs other than those incurred by HEAT & GLO to repair or replace the defective component.

This Limited Warranty is the exclusive remedy available to you. If HEAT & GLO cannot effectively resolve a warranty problem in an expedient and cost-effective manner, it can discharge its entire warranty liability by refunding the price of the product to you.

Products made by other manufacturers, whether sold with the stove or added thereafter, are NOT covered by this Limited Warranty. The use of other unauthorized components will make this warranty null and void. This Limited Warranty will also be void if the appliance is not installed by a qualified installer in accordance with the Installation Instructions. Furthermore, the Limited Warranty will be void if the stove is not operated, at all times, according to the User's Manual furnished with the stove. Any service work must be performed by authorized service representatives.

EXCEPT TO THE EXTENT PROVIDED BY LAW, NO OTHER EXPRESS OR IMPLIED WARRANTIES, INCLUDING WARRANTIES OF MERCHANTABILITY OR FITNESS FOR A PARTICULAR PURPOSE, SHALL APPLY TO THE FIREPLACE PRODUCT. In States that do not allow limitations on how long an implied warranty lasts, or do not allow exclusion of indirect damages, those limitations or exclusions may not apply to you. You may also have additional rights not covered in this Limited Warranty.

HEAT & GLO reserves the right to make changes at any time, without notice, in design, material, specifications and prices. It also reserves the right to discontinue styles and products.

Please complete this information and retain this warranty in a safe place for future reference:

Installation Date: _____ Model # _____ Serial # _____ Installing Contractor: _____

G. Contact Information



No one builds a better fire

Heat & Glo, a brand of Hearth & Home Technologies, Inc.
20802 Kensington Boulevard
Lakeville, MN 55044, USA

Please contact your Heat & Glo dealer
with any questions or concerns.
For the number of your nearest Heat & Glo dealer,
please call 1-888-427-3973 or visit www.heatnglo.com

	CAUTION
	Do NOT discard this manual. <ul style="list-style-type: none">• Important operating and maintenance instructions included.• Read, understand and follow these instructions for safe installation and operation.• Leave this manual with party responsible for use and operation.



Your Records for Model:
VRTIKL-CE Balanced Flue Gas Appliance

SERIAL NUMBER: _____

DATE PURCHASED: _____

DATE INSTALLED: _____

DEALERSHIP WHERE PURCHASED: _____

DEALER TELEPHONE: _____

This product may be covered by one or more of the following patents: (United States) 4593510, 4686807, 4766876, 4793322, 4811534, 5000162, 5016609, 5076254, 5113843, 5191877, 5218953, 5263471, 5328356, 5341794, 5347983, 5429495, 5452708, 5542407, 5601073, 5613487, 5647340, 5688568, 5762062, 5775408, 5890485, 5931661, 5941237, 5947112, 5996575, 6006743, 6019099, 6048195, 6053165, 6145502, 6170481, 6237588, 6296474, 6374822, 6413079, 6439226, 6484712, 6543698, 6550687, 6601579, 6672860, 6688302B2, 6715724B2, 6729551, 6736133, 6748940, 6748942, 6769426, 6774802, 6796302, 6840261, 6848441, 6863064, 6866205, 6869278, 6875012, 6880275, 6908039, 6919884, D320652, D445174, D462436; (Canada) 1297749, 2195264, 2225408, 2313972; (Australia) 780250, 780403, 1418504 or other U.S. and foreign patents pending.