

THE SCIENCE



OF SURVIVAL

COBHAM

INSTALLATION MANUAL

NAUTICAST // Automatic Identification System - Inland

Product No.: 2662

Y1-03-0212 Rev. E

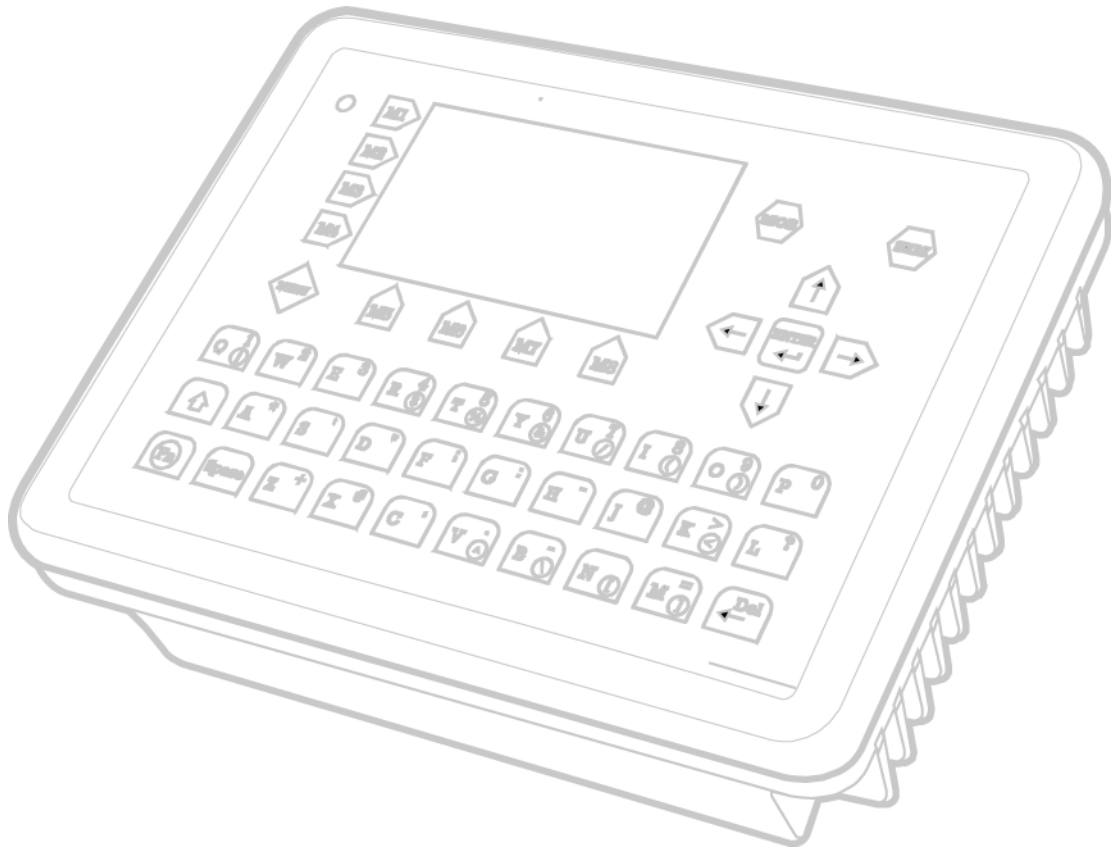

FC

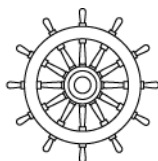

ACR Electronics, Inc. // 5757 Ravenswood Road // Fort Lauderdale // FL // 33312-6645

Tel: +1 (954) 981-3333 // Fax: +1 (954) 983-5087 // www.acrelectronics.com

Please read this first!

Warning:

Although ACR strives for accuracy in all its publications; this material may contain errors or omissions, and is subject to change without prior notice. ACR shall not be made liable for any specific, indirect, incidental or consequential damages as a result of its use. ACR components may only be used in safety of life devices or systems, with the express written approval of ACR, as the failure of such components could cause the failure of the ACR device or system. If these fail, it is reasonable to assume that the safety of the user or other persons may be endangered.

Copying of this document, and giving it to others and the use or communication of the contents thereof, are forbidden without express authority. Offenders are liable to the payment of damages.

Weitergabe sowie Vervielfältigung dieser Unterlage, Verwertung und Mitteilung ihres Inhaltes nicht gestattet, soweit nicht ausdrücklich zugestanden. Zuwiderhandlungen verpflichten zu Schadenersatz.

Toute communication ou reproduction de ce document, toute exploitation ou communication de son contenu sont interdites, sauf autorisation expresse. Tout manquement à cette règle est illicite et expose son auteur au versement de dommages et intérêts.

Sin nuestra expresa autorización, queda terminantemente prohibida la reproducción total o parcial de este documento, así como su uso indebido y/o su exhibición o comunicación a terceros. De los infractores se exigirá el correspondiente resarcimiento de daños y perjuicios.

1	GENERAL INTRODUCTION	1
1.1	Description of AIS	1
1.2	AIS in an Operational Environment	2
1.3	AIS Networks	3
2	NAUTICAST	4
2.1	System Overview	4
3	INSTALLATION	5
3.1	Installation Requirements	5
3.2	Installation Overview	5
3.3	General Interface Description	7
3.4	Interface NMEA Description:	8
3.4.1	Sensor - Interface CH1, CH2, CH3	8
3.4.2	ECDIS – Presentation Interface CH 4	8
3.4.3	Pilot Port CH 5	9
3.4.4	Long Range CH 8	9
3.4.5	DGPS – DGNSS Channel 9	10
3.4.6	Alarm Circuit – BIIT Channel 10	10
3.4.7	Proprietary Sentences	10
3.5	Sensor Interface Definitions	11
3.5.1	Talker drive circuits	11
3.5.2	Listener Receiver Circuits	11
3.5.3	Electrical isolation	11
3.5.4	Maximum voltage on the bus	11
3.5.5	Data transmission	11
3.6	Sensor notes	12
3.7	Sensor Hardware Installation:	13
3.7.1	Installation of an RS422 serial interface:	13
3.8	Sensor Software Configuration	14
3.8.1	Introduction	14
3.8.2	Set up Sensor Speed, Checksum (CRC) and NMEA Talker and Sentence ID	14
3.8.3	Real-Time Analysis of NMEA Data Streams	17
3.8.4	Sensor Monitoring for Problem Analysis	19
3.8.5	Priority Handling of Sensor Sentence	20
3.8.6	Supported NMEA-0183 Sentences	20
3.8.7	Calculated Values	23
3.8.8	Versions of NMEA Sentences	24
3.9	Pin-Description AIS-Cable / Socket 50-Pins:	25
3.10	Pin-Description AIS-Connector:	26
3.11	Pin-Description Communication-Cable / Socket 50-Pins	27
3.12	Communication Cable RS232 (Sub-D 50 Socket)	28
3.13	Installation of VHF / GPS Antennas	29
3.13.1	VHF Antenna Installation	29
3.13.2	GNSS Antenna installation	30
3.14	Power Supply	31
4	STARTING THE NAUTICAST	32
4.1	Initial Set Up of the NAUTICAST for operation	32
4.2	Entering the MMSI / IMO / DAC / ESN Numbers	33
4.3	Entering Ship Settings	36
4.4	Entering Voyage Related Data	38
4.5	Entering Inland AIS Configuration	42
4.6	Service and User Passwords	44
5	TROUBLESHOOTING	47
5.1	Reading and understanding Alarms:	47
5.2	Alarm Codes	48
5.3	Text Messages	49
5.4	Restarting the NAUTICAST	49
6	ACCESSORIES	50
7	TECHNICAL INFORMATION	51
7.1	ERI Ship Types	52
8	CONTACT AND SUPPORT INFORMATION	53
9	APPENDIX	54
9.1	Samples for battery calculation	54
9.1.1	Typical Installation	54
9.1.2	RM GMDSS Compact-Console Area A3 with 250 W MF/HF	55
9.1.3	RM GMDSS Compact-Console Area A3 with 400 W MF/HF	55
9.2	Drawings and Approvals	56

History of Changes

Date	Version	Rev.	Status	Comments	Responsible
2005-11-01	1.0.0	A	Released		A. Lesch
2006-07-14	1.0.1	B	Released	Editorial work	M. D'Arcangelo
2006-10-11	1.0.2	C	Released	Character Change-out Edits	M.D'Arcangelo
2008-12-05	1.0.5	D	Released	Update according to VTT&T, Blue Sign, Factory Password handling, removed reference to specific default password and noted this is now on the protective cover on the unit display.	C. Kabinger, B. Werner

1 General Introduction

1.1 Description of AIS

What does the abbreviation AIS stand for?

AIS stands for: "Automatic Identification System"

What is AIS?

According to IALA regulations, AIS is defined as follows:

Very simply, the AIS is a broadcast Transponder system, operating in the VHF maritime mobile Band. It is capable of sending ship information such as identification, position course, speed and more, to other ships and to shore. It can handle multiple reports at rapid update rates and uses Self-Organizing Time Division Multiple Access (SOTDMA) technology to meet these high broadcast rates and ensure reliable and robust ship to ship operation.

What are the performance standards of AIS?

The IMO defines the performance standards as follows:

- Ship to Ship working
- Ship to Shore working, including Long Range Application
- Automatic and continuous operation
- Provision of information messaging
- Utilization of maritime VHF channels

Which modules make up an AIS-Transponder?

The Modules:

- DGPS / GPS receiver
- VHF Radio
- Antenna
- Computer (CPU)
- Power Supply

Appropriate application software connects the individual modules.

In which modes does AIS function?

AIS are required to function flawlessly in a variety of modes. The relevant regulations require:

The system shall be capable of

- An "**autonomous and continuous**" mode for operation in all areas. This mode shall be capable of being switched to/from one of the following alternate modes by a competent authority;
- An "**assigned**" mode for operation in an area subject to a competent authority responsible for traffic monitoring such that the data transmission interval and/or time slots may be set remotely by that authority;
- A "**polling or controlled**" mode, where the data transfer occurs in response to interrogation from a ship or competent authority.

1.3 AIS Networks

The scenario below shows a full AIS coverage area (including all applications and complete shore infrastructure).

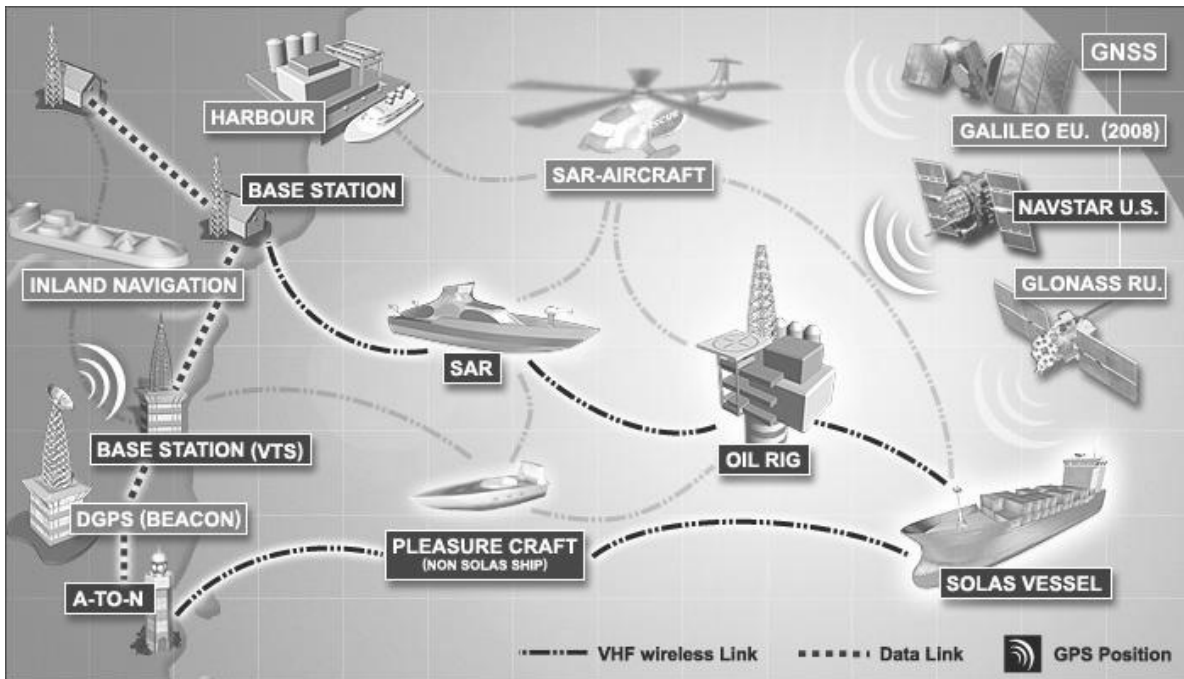

The Carriage Requirement currently applies to SOLAS Vessels and will be extended on Inland Waterways.

2 NAUTICAST

2.1 System Overview

Unlike other AIS devices, the NAUTICAST combines all required functions into one cabinet. Additionally, the NAUTICAST gives the operator a number of additional features (easy mounting & installation, environmental protection and smallest dimensions).

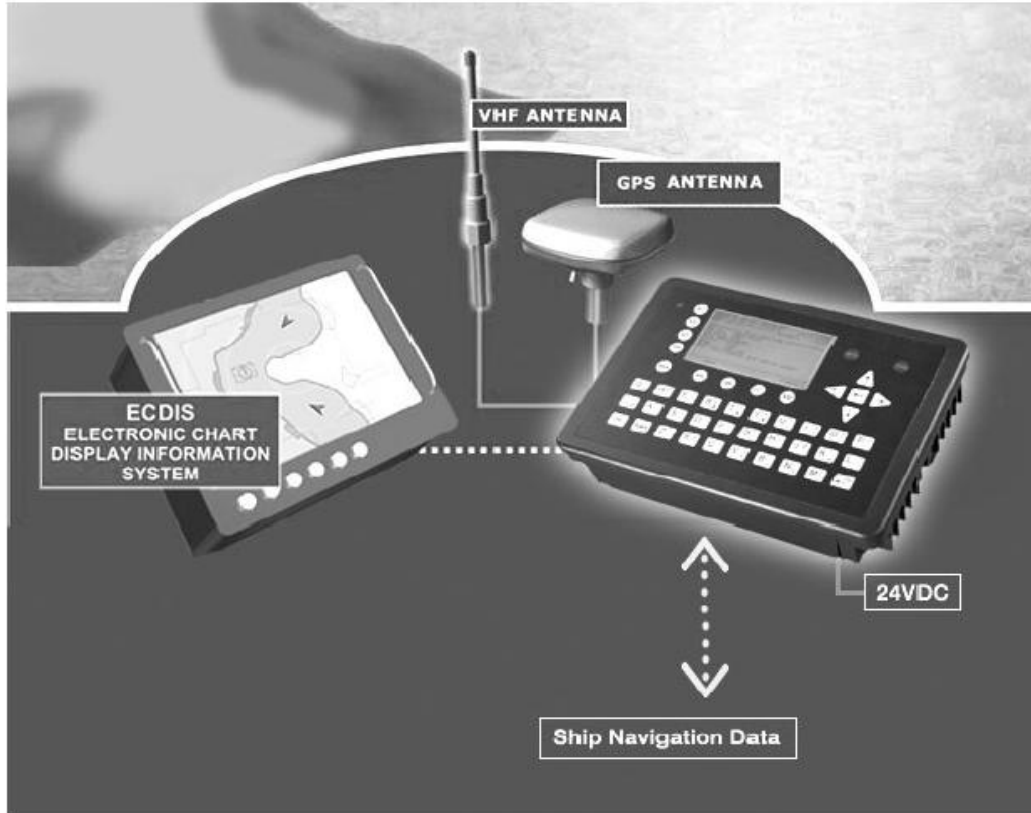
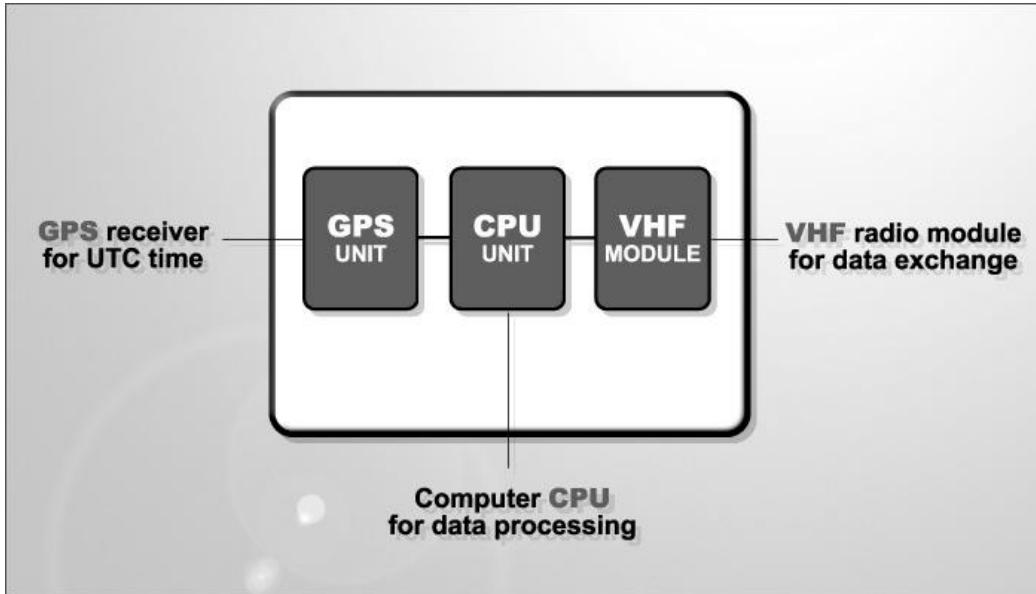

3 Installation

IMPORTANT: AUTHORITIES MANDATE that after the physical installation has been successfully completed, all ships data and settings be entered into the AIS transponder. See Section 4 for further instructions.

3.1 Installation Requirements

General Requirements

Please note that international conventions, regulations, instructions and guidelines have to be adhered to when installing the NAUTICAST.

The following points must be observed before installation can commence:

- Permission by the local authority to install such a device must be granted.
- Trained service personnel must undertake the installation.
- The NAUTICAST must be fitted in a suitable place on the bridge.
- The VHF and GPS Antennas must be installed in a suitable position, where excellent reception conditions apply (refer to Chapter 3.10 Installation of VHF antenna)
- All available interfaces must be installed.
- The vessels power supply must suffice, and the GMDSS power supply has to be used.
- Installation of the pilot plug in conning position (close to the pilot working place).

3.2 Installation Overview

Survey

AIS is considered part of the ship's radio station and is surveyed together with radio installation. Surveys on SOLAS Convention ships should be carried out in accordance with the rules laid down in IMO Res. A 746(18) "Survey Guidelines under the harmonized system of survey and certification" (R) 8, and "Protocol of 1988 relating to the International Convention for the Safety of Life at Sea, 1974."

The NAUTICAST consists of one unit, which integrates all necessary modules.

Step-by-Step Installation Procedure:

- Mount the NAUTICAST close to ships operation workstation for traffic surveillance and maneuvering.
- Use the VHF adapter cable (P/N 2612) together with the VHF plug and TNC plug to connect the VHF and GPS antenna cables and antennas.
- The sensors, ECDIS, PC, pilot case, long range devices and auxiliary displays can be connected to the NAUTICAST cabinet by the AIS cable by means of the connection box. The device is driven by a 24V DC 7A supply, which is connected to the power terminal at the connection box. The AIS should be connected to an emergency power source. A battery capacity calculation together with GMDSS-equipment is needed! Please refer to Appendix 9.1 for examples of battery capacity calculations.
- After performing these steps, the NAUTICAST automatically starts operation.
- The NAUTICAST has a ground terminal which has to be connected to ship ground.
- Now configure the required initial system parameters according to Chapter 4 “Starting the NAUTICAST.”

NAUTICAST

Connection Diagram

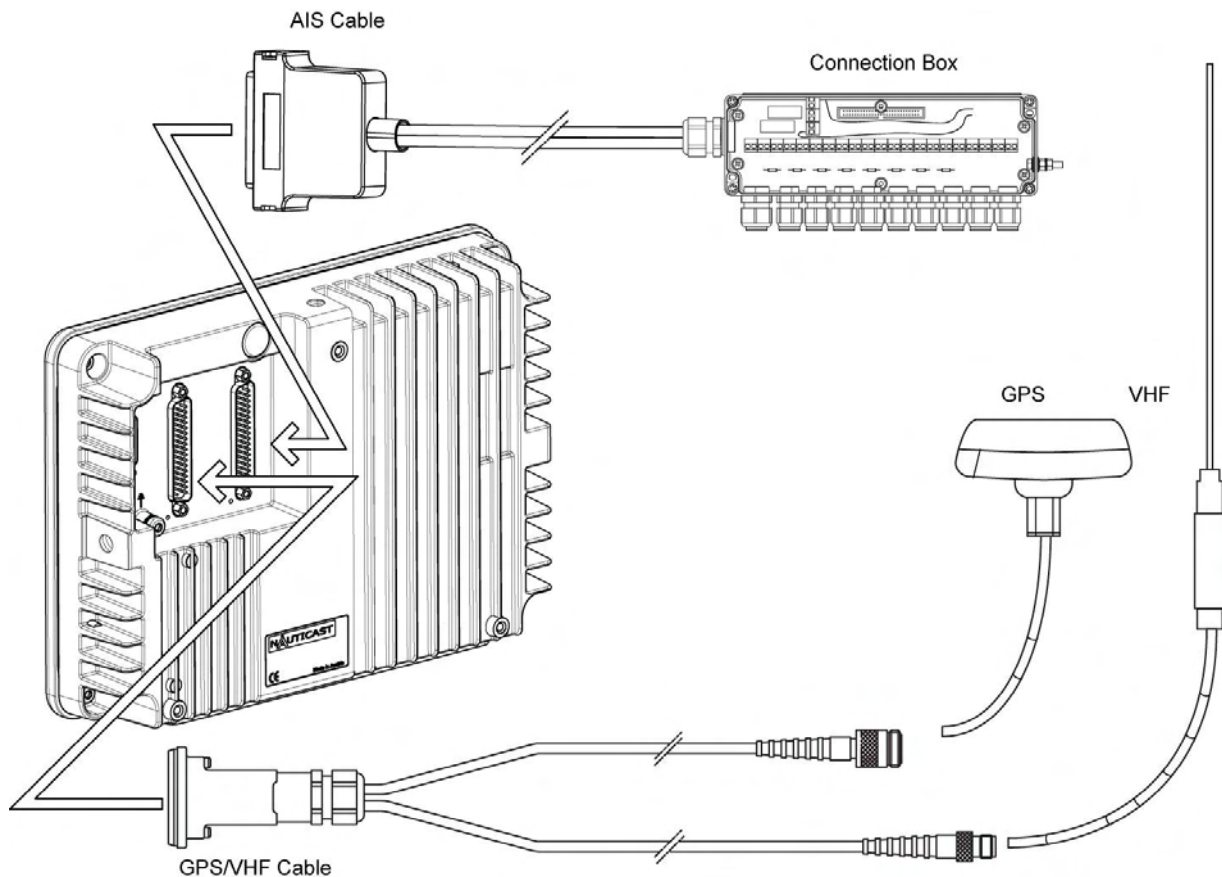

Note: The optional ACR connection box includes a fuse of 6,3A. If it is not used, then the unit has to be protected against high current by an external slow blow fuse of 6,3A.

Components and Interfaces

The diagram below illustrates which devices can be connected to the NAUTICAST. For a detailed description of sensor connecting e.g. an existing Gyro to the NAUTICAST refer to Chapter 3.5 "Sensor Interface Definitions."

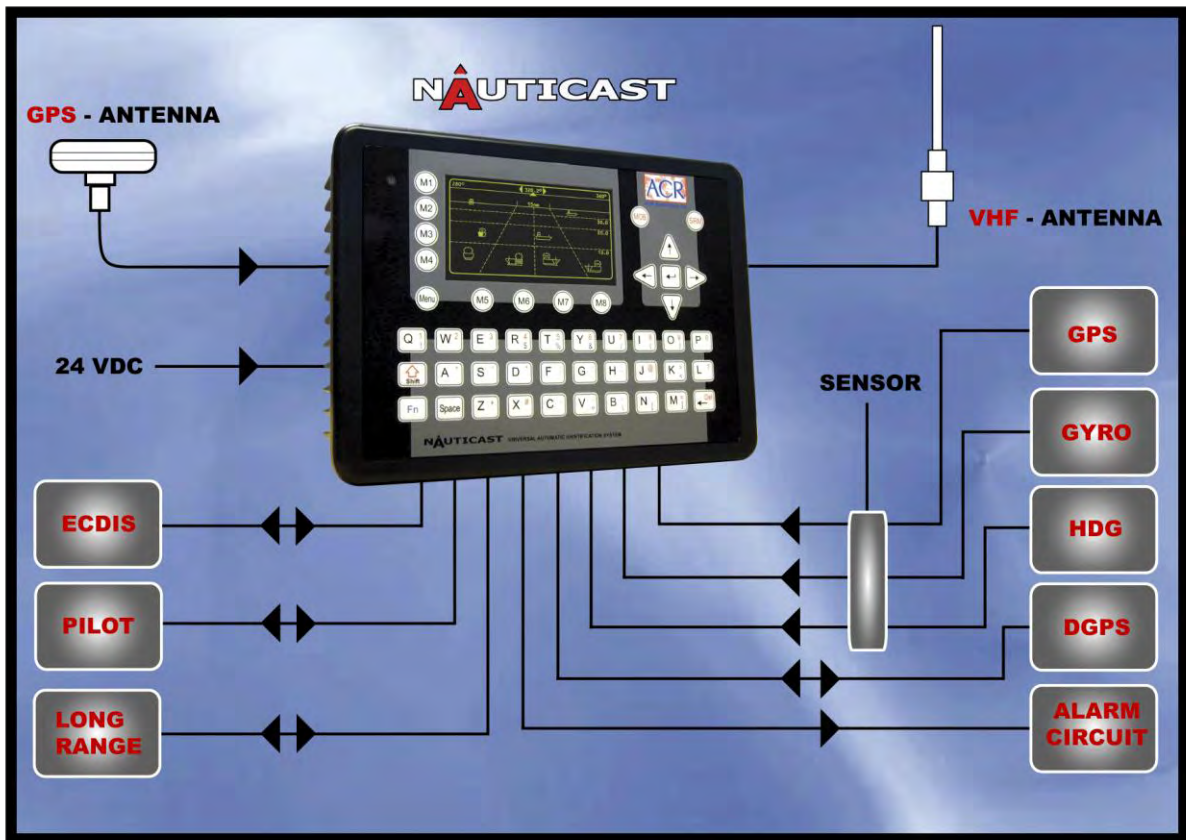

3.3 General Interface Description

Interface	Designation	Speed	Direction
Sensor 1	CH 1	4800bps or 38400bps	Input
Sensor 2	CH 2	4800bps or 38400bps	Input
Sensor 3	CH 3	4800bps or 38400bps	Input
ECDIS	CH 4	38400bps	Input/Output
PILOT	CH 5 / CH 15	38400bps	Input/Output
LONG RANGE	CH 8	38400bps	Input/Output
DGPS (RTCM SC104)	CH 9	9600bps	Input/Output
ALARM CIRCUIT	CH 10	Dry relay contact (power off and alarm state closed)	

3.4 Interface NMEA Description:

3.4.1 Sensor - Interface CH1, CH2, CH3

Refer to Chapter 3.8 for detailed information on Sensor - Interface and Configuration.

3.4.2 ECDIS – Presentation Interface CH 4

Sentence Formatters		Direction	Used Fields
ABK	UAIS Addressed and binary broadcast acknowledgement	out	All fields are provided for Input and Output. For further information please refer to IEC 61993-2 / NMEA 0183 HS V3.0 for detailed field information.
ACA	AIS Channel assignment message	in / out	
ACK	Acknowledge Alarm	in	
AIR	UAIS Interrogation Request	in	
ALR	Set Alarm State	out	
ABM	UAIS Addressed binary and safety related message	in	
BBM	UAIS Broadcast Binary Message	in	
DSC	Digital Selective Calling Information	out	
DSE	Expanded Digital Selective Calling	out	
DSI	DSC Transponder Initialize	out	
DSR	DSC Transponder Response	out	
LRI	UAIS Long-Range Interrogation	out	
LRF	UAIS Long-Range Function	out	
SSD	Station Static Data	in	
TXT	Text Transmission	out	
VSD	Voyage Static Data	in	
VDM	UAIS VHF Data-link Message	out	
VDO	UAIS VHF Data-link Own-vessel report	out	

3.4.3 Pilot Port CH 5

The used sentence formatters for the pilot plug are the same as those listed for the ECDIS port.

Note: A pilot input/output port is part of an AIS Class A installation. A plug connected to this port should be installed on the bridge near the pilot's operating position, so that a pilot can connect a Personal Pilot Unit (PPU) if required. Also, a power connector for the pilot unit should be available nearby.

The pilot plug should be configured as follows: (Refer to SUB-COMMITTEE ON SAFETY OF NAVIGATION NAV48/18 2.4.2002)

AMP/Receptacle (Square Flanged (-1) or Free-Hanging (-2)), Shell size 11, 9-pin, Std. Sex 206486-1/2 or equivalent with the following connections:

- Tx A (out-) is connected to Pin 1
- Tx B (out+) is connected to Pin 4
- Rx A (in-) is connected to Pin 5
- Rx B (in+) is connected to Pin 6
- Shield is connected to Pin 9

3.4.4 Long Range CH 8

The AIS long range function requires a compatible long range communication system (e.g. Inmarsat-C or MF/HF radio as part of GMDSS). This connection is required in order to activate the long range function of the AIS. Its input/output port must meet the IEC 61162-2 requirements.

Sentence Formatters		Direction
LRI	UAIS Long Range Interrogation	Input
LRF	UAIS Long-Range Function	Input / Output
LR1	UAIS Long-Range Reply Sentence 1	Output
LR2	UAIS Long-Range Reply Sentence 2	Output
LR3	UAIS Long-Range Reply Sentence 3	Output
	Field Information: All fields are provided for input and output. For further information please refer to IEC 61993-2 / NMEA 0183 HS V3.0 for detailed field information.	

3.4.5 DGPS – DGNSS Channel 9

Field / Protocol information:

All fields are provided with further information; please refer to ITU-R M.823-2 / RTCM SC 104 for detailed field information.

3.4.6 Alarm Circuit – BIIT Channel 10

The AIS requires that an alarm output (relay) must be connected to an audible alarm device or the ships alarm system, if available.

Alternatively, the BIIT (built-in integrity test) alarm system may use the alarm messages output on the presentation port (ECDIS Port Channel 5), provided the ECDIS alarm system is connected and AIS compatible.

3.4.7 Proprietary Sentences

The proprietary ACR NMEA sentences have the NMEA registered manufacture talker ID “**NAU**”. The \$PNAU sentences are an addition to the standard sentences and offer other manufactures full remote control to the Transponder. The additional “Extended NMEA command set” – manual, which could be requested on demand, includes the full description of how to use the proprietary NAUTICAST sentences.

Proprietary NMEA-Sentences \$PNAU

- MID - Mobile (MMS) Id
- ASD - Advanced Ship Data
- RCS - Read Configuration Settings
- STO - Set Transponder Options
- TSI - Transponder State Information
- SCR - Sensor Configuration Request
- SCA - Sensor Configuration Acknowledge
- SCD - Sensor Configuration Data
- SCM - Sensor Configuration Mode
- AIQ - Request status information from the Transponder
- IVD – Inland AIS voyage data
- SPW- Inland AIS security password sentence
- SPR- Inland AIS security password response

3.5 Sensor Interface Definitions

All interface ports of the NAUTICAST comply with IEC-61162-1 / -2 and NMEA-0183 HS 3.0 specifications (aligned to RS422 parameters).

3.5.1 Talker drive circuits

The maximum output current is $I_{\max} = 50\text{mA}$ on each port. The drive circuit meets the requirements of ITU-T V.11.

3.5.2 Listener Receiver Circuits

Multiple listeners may be connected to a single talker. Optional termination resistors (120Ohm) for the input lines are provided in the connection box. The input terminals A, B and C are electrically isolated from the remaining electronics of the listening device.

The input impedance is 30kOhm between A and B lines, disregarding the connection of termination resistors. The minimum input voltage is $\pm 0,3\text{V}$.

The listener's receiver circuit complies with ITU-T V.11.

3.5.3 Electrical isolation

There are no direct electrical connections between the signal lines A and B.

The signal ground C must not be connected to the ship main ground or power line!

This isolation is in accordance with IEC 60945.

3.5.4 Maximum voltage on the bus

The maximum applied voltage between signal lines A and B and between either line and ground C is in accordance with ITU-T V.11. For protection against incorrect wiring and for unintended connection to older TALKER models, all receiver circuit devices are capable of withstanding 15 V between both lines and signal ground for an indefinite period.

3.5.5 Data transmission

Data is transmitted in serial asynchronous form in accordance with IEC 61162-1. The first bit is a start bit, and is followed by data bits, whereby the least significant bit is first.

The following parameters are used:

- Baud rate 38 400 (bits/s) 9600 (bits/s) 4 800 (bits/s)
- Data bits 8 (D7 = 0), parity none
- Stop bits 1.

3.6 Sensor notes

External Sensor

The AIS has interfaces (configurable as IEC 61162-1 or 61162-2) for position, bottom track (BT) speed, heading and rate of turn (ROT) sensors. In general, sensors installed in compliance with other carriage requirements of SOLAS Chapter V should be connected to the AIS System.*1. The sensor information transmitted by AIS should be the same information being used for navigation of the ship. Interfacing problems might occur if the existing on board sensors do not have serial (IEC 61162) outputs. A converter is needed to translate the non conform data to IEC 61162 – sensor data. For Example ACR Converter type P/N 2641.

*1) The fact that AIS is fitted on board a vessel does **NOT** entail the need to install additional sensors other than those stated in the carriage requirements.

External GPS

GNSS position sensors normally have IEC 61162 outputs suitable for direct AIS interfacing. However, it is important to note that:

- The Geodetic Datum of the position data is transmitted by the sensor in WGS84 so that an IEC 61162 DTM sentence is configured.
- AIS is able to process two reference points for its antenna position, one for external, and one for an internal sensor. If more than one external reference point is used, the appropriate information needs to be input to the AIS, so that the reference point information is suitably adjusted.

External Heading

A gyrocompass providing heading information is a mandatory sensor input to the AIS. A converter unit (synchro or step-signal converter to NMEA 0183 v.3.0 for example ACR Converter type P/N 2641) will be needed for AIS connection in the case that the ship's gyrocompass does not provide IEC 61162 output.

External Speed and Course

If a bottom track (BT) log for Speed Over Ground (SOG) is available, it may be connected. A converter (for example ACR Converter type P/N 2641) is needed if the BT-log does not provide IEC 61162 outputs.

External Rate of Turn

Not all ships will carry a Rate-Of-Turn (ROT) indicator according to IMO A.526. However, if a rate-of-turn indicator is available and it includes an IEC 61162 interface, it should be connected to the AIS.

If ROT information is not available from a ROT indicator, it may (optionally) be derived from heading information through:

- The gyrocompass itself,
- An external converter unit (see Heading),
- The AIS itself (calculated ROT).

3.7 Sensor Hardware Installation:

3.7.1 Installation of an RS422 serial interface:

In most cases, the output from a GPS is already being used by existing navigation equipment. It is possible to split an RS 422 output for two devices. If the signal becomes too low, then an NMEA splitter has to be used.

Example for single talk multi-listener connection:

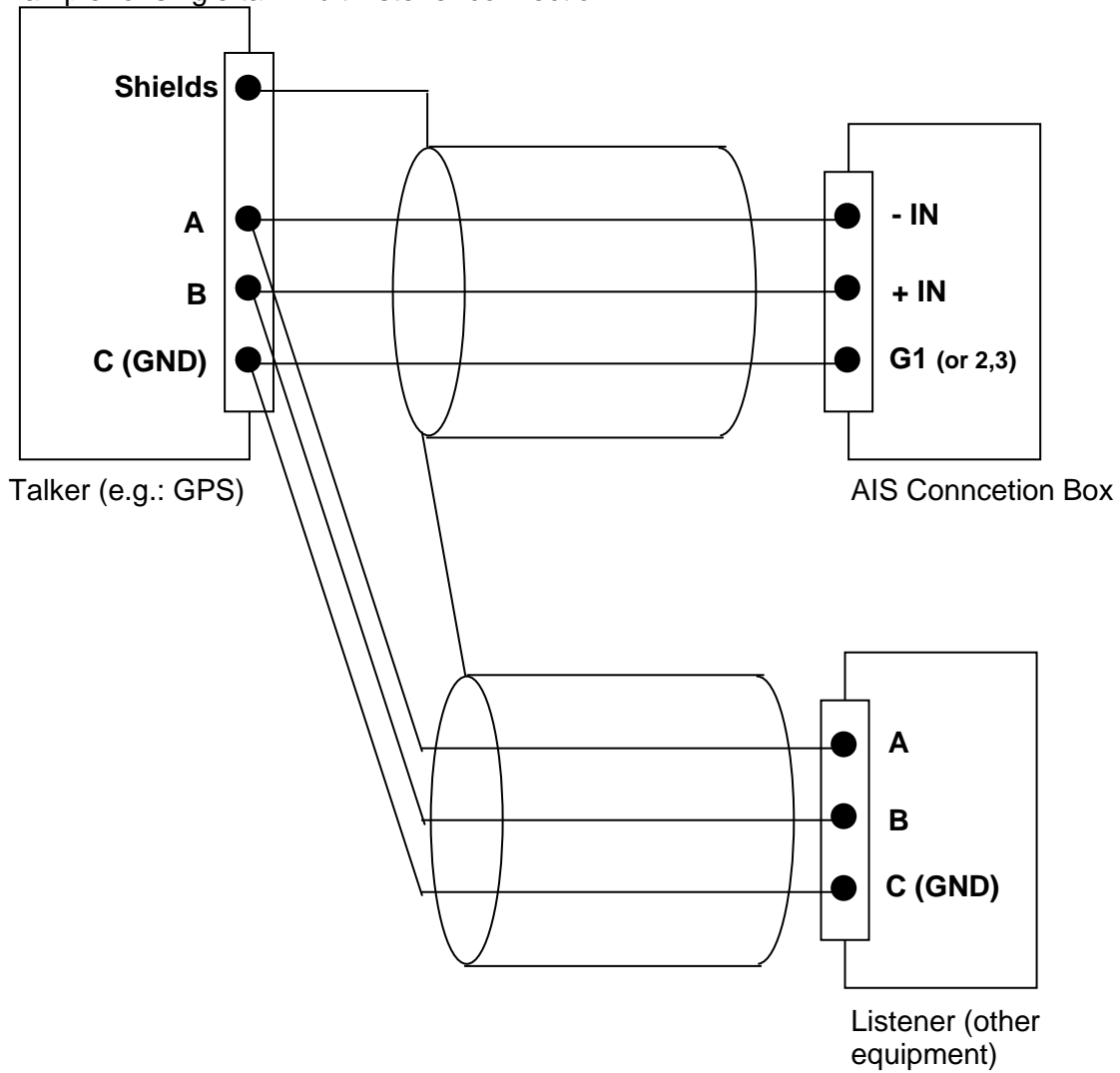

Each interface on the Transponder is a RS422 serial interface
The shield or ship main ground should not be connected with the signal ground (GND).

3.8 Sensor Software Configuration

3.8.1 Introduction

The NAUTICAST AIS requires a connection to various sensor devices. Sensor Configuration should enable compatibility with existing navigation devices aboard any vessel. This chapter deals with several ways to configure the NAUTICAST and to comply with the requirements of the specific sensor interfaces.

Configuration and display is visible on two screens of the Sensor Configuration Menu. The NAUTICAST offers the following configuration options:

- Set up data speed 4800/9600/38400 baud.
- Monitor the connected sensor inputs for each sensor channel.
- Verify and edit the Sensor Configuration on the display screen.
- Analyze the information received from the connected sensor devices.
- Produce an electronic installation report.
- Configuration of various NMEA protocols.

The individual options may be repeated until the required configuration for the connected sensor devices is achieved.

During the configuration process, the NAUTICAST is not operational.

3.8.2 Set up Sensor Speed, Checksum (CRC) and NMEA Talker and Sentence ID

The Sensor configuration is accessible via the submenu '5. Sensor Settings' in the Service Password protected menu: '5. Transponder Configuration'. Please see the appendix in your User Manual for password information.

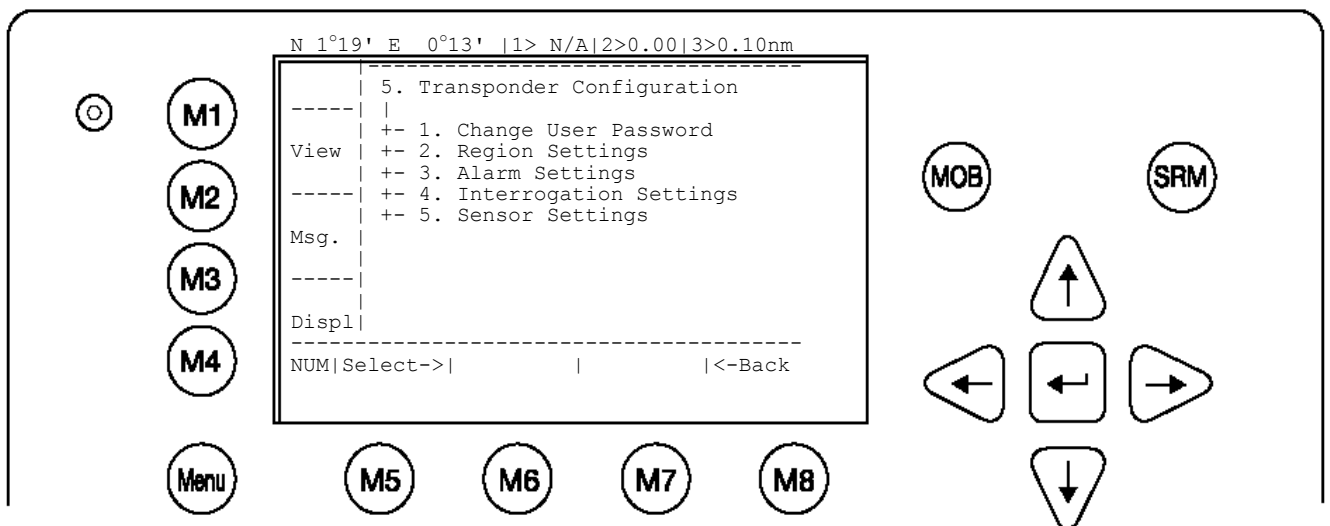

After accessing the Sensor Configuration menu this main configuration screen is active:

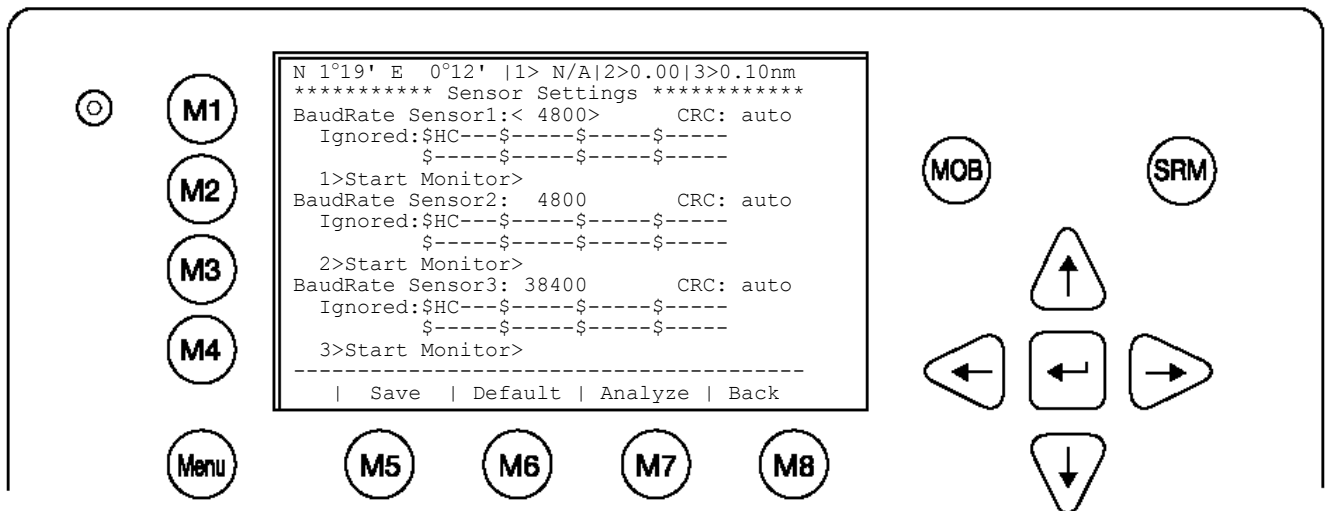

A variety of possible settings can be made on this screen. It is possible to navigate from one configuration item to another by pressing the **up** and **down** arrow keys. Value will be changed by pressing the left and right arrow key. The fastest way to jump from one sensor to another is by pressing numbers 1 – 3 on the keyboard. (Refer also to chapter 3.8.4 for specific information on a particular sensor)

The following changes can be undertaken for each of the sensor interfaces (by **left** and **right** arrow key):

- Changing the baud rate (4800, 9600 and 38400) to the required speed of the sensor device by pressing the right or left arrow keys.
- Enabling or disabling CRC-Checking by pressing the right or left arrow keys.
 <auto> Sentence will be accepted with or without Checksum
 <on> Checksum must be available
- Configuring NMEA sentences, which the system filters and ignores
 There are 5 entry fields where characters can be input. Two positions of each entry field are for Talker-Id, and three for Sentence-Id, which represents the NMEA-sentence which should be ignored by the system.

(i.e. the default setting: “HC” means ignore all NMEA records starting with HC on this particular sensor interface)

Note: HC stands for magnetic north and should be ignored.

For Example:

--VTG means all VTG sentence IDs will be ignored like GPVTG, GNVTG...

VW--- means all VW Talkers ID from speed log will be ignored like VVVHW, VVVBW

Changes on this screen can be saved by pressing the **“Save”** – Button [M5].

The factory settings can be recalled by pressing the **“Default”** – Button [M6].

Returning back to the previous screen is possible by pressing the **“BACK”** – Button [M8].

The next step is the analysis of the current sensor interface settings, which can be undertaken with the **“Analyze”** – Button [M7]. After pressing this button, the real-time analysis of the sensor data stream begins. This process takes around 30 seconds and is visible on a temporary screen.

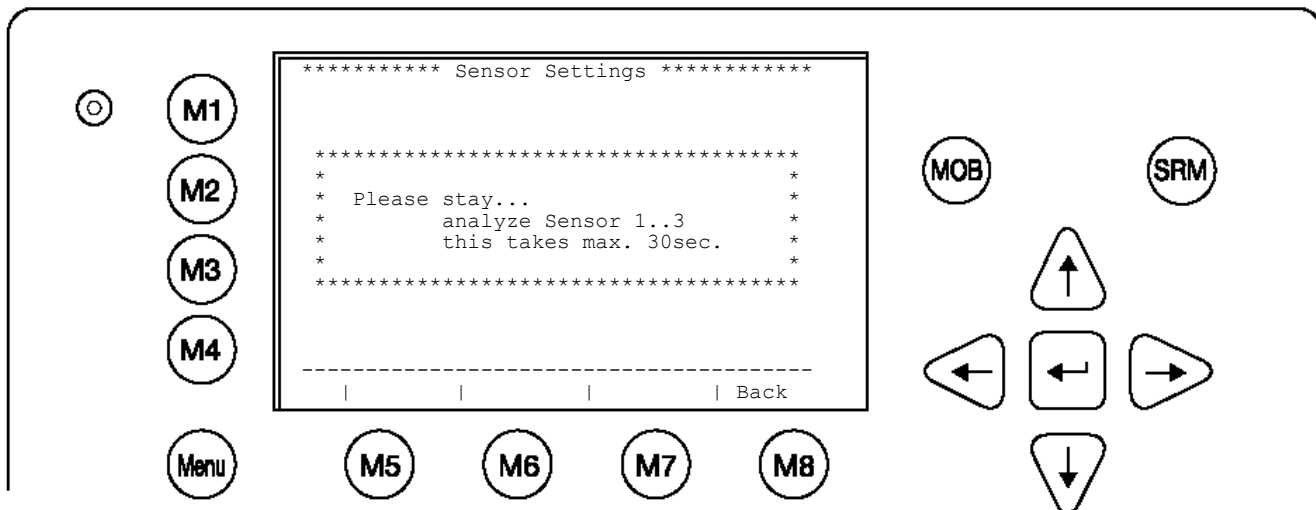

It is possible to interrupt this process by pressing the **“Back”** - Button [M8].
 After the analysis is complete, the Transponder will list the data used for the AIS operation.

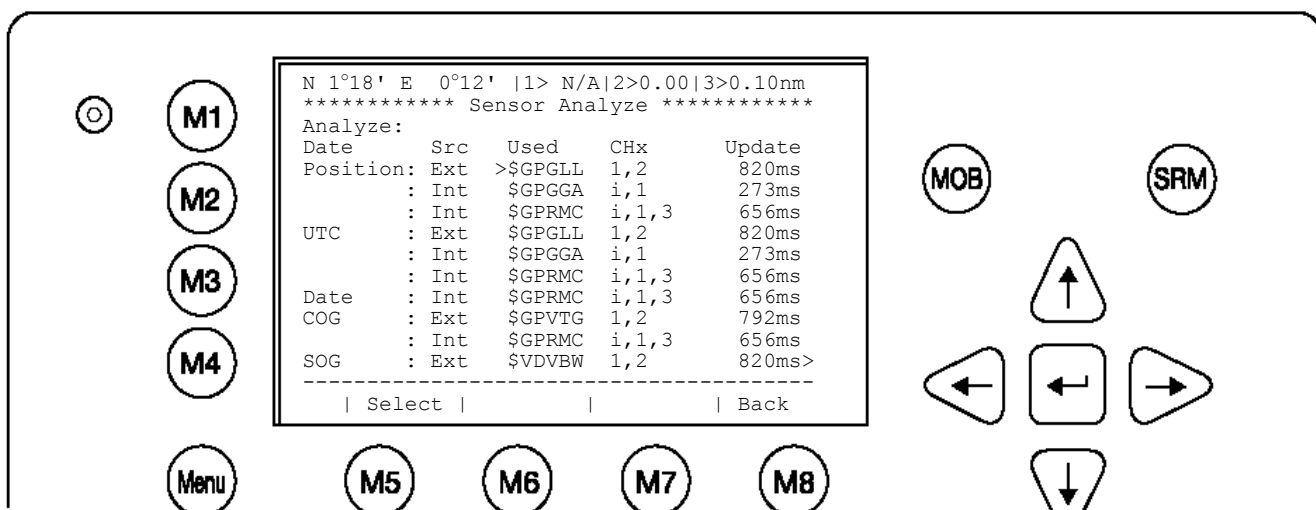

3.8.3 Real-Time Analysis of NMEA Data Streams

After these configuration procedures, an overview of the current Sensor Software Configuration has been attained.

This filtered NMEA data can be analyzed further. The data source is shown on the screen below. The source can be internal or external devices, the received NMEA sentence and the channel where this data was identified (Sensor 1, 2, 3 or calculated), as well as the measured update rate.

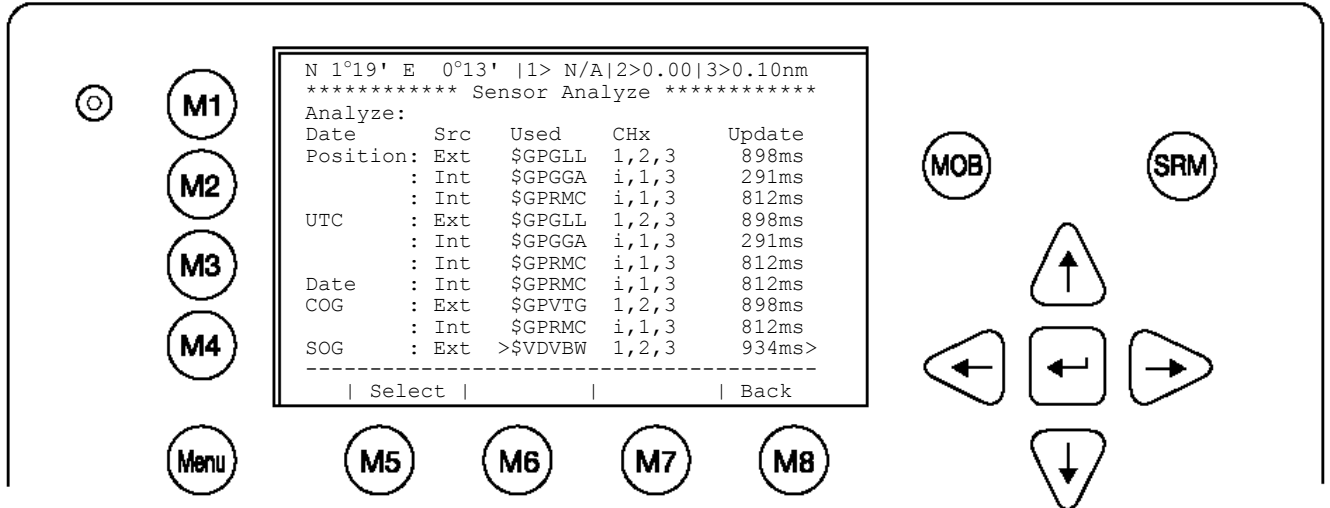

To view any NMEA sentence in detail, the required data line can be selected by pressing [Enter]. The detailed information on this source appears as follows:

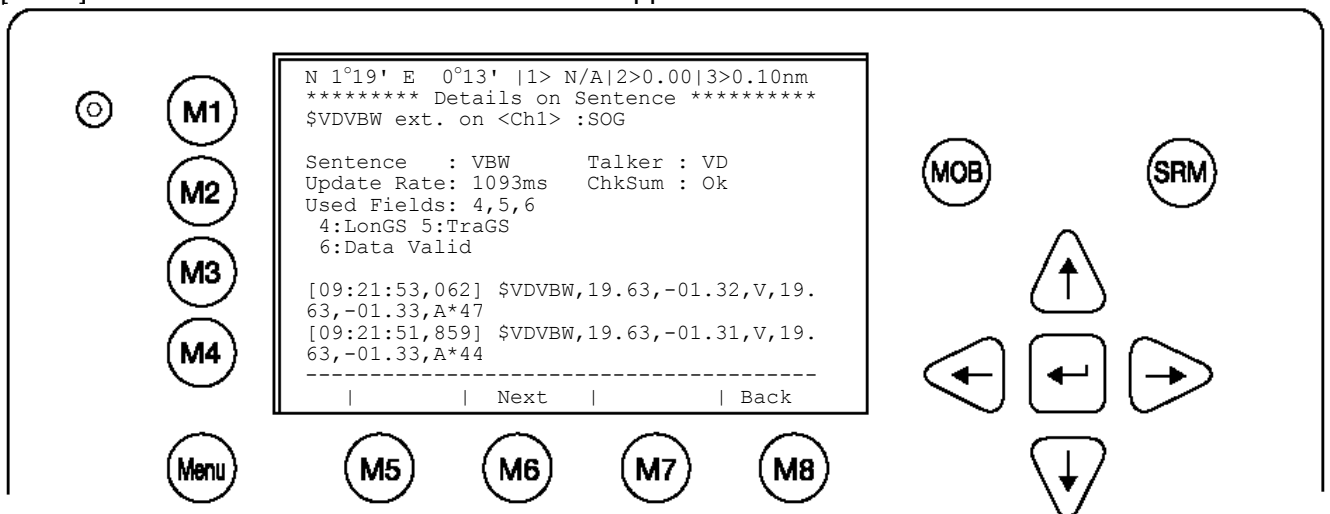

It is possible to scroll through the sources of this sensor interface channel by pressing the “**Next**” –Button [M6]. The previous menu can be accessed at any time by pressing the “**Back**” – Button [M8].

Each time the analysis process for sensor configuration is undertaken; a trace file (see below) is automatically generated and sent out to the ECDIS-Port. This output can also be used as a Sensor Configuration Report.

```

$PNAUSCA,4800,4800,4800,1
$PNAUSCD,----- Sensor Settings -----
$PNAUSCD,Date      : 06/22/2004 08:57:05
$PNAUSCD,Hardware: AIS Transponder Class A
$PNAUSCD,Software: 2.0.0.11R3
$PNAUSCD,SW Stamp: Jun 14 2004 11:46:10
$PNAUSCD,LAT      : N 53°30.123' LON : E 10° 1.234'
$PNAUSCD,Heading : ExtHDT:0° iRot : 0°/min
$PNAUSCD,IMO No. : 303174162 MMSI: 2222222
$PNAUSCD,ShipName: U4 CS : D11233
$PNAUSCD,ShipType: Pilot vessel
$PNAUSCD,Length  : 220m Beam: 43m
$PNAUSCD,RefPtExt: A200 B20 C10 D33m
$PNAUSCD,RefPtInt: A190 B30 C20 D23m
$PNAUSCD,Cargo   : N/A or harmless
$PNAUSCD,Draught : 24.8m
$PNAUSCD,Dest.   : CASABLANCA
$PNAUSCD,ETA     : 10/13 12:31
$PNAUSCD,NavStat : Engaged in fishing
$PNAUSCD,EPRFDType: GPS
$PNAUSCD,----- Sensor Settings -----
$PNAUSCD,BaudRate Sensor1: 4800 CRC:auto
$PNAUSCD,Ignored:$-----$-----$-----$-----
$PNAUSCD,          :$-----$-----$-----$-----
$PNAUSCD,BaudRate Sensor2: 4800 CRC:auto
$PNAUSCD,Ignored:$HC---$-----$-----$-----
$PNAUSCD,          :$-----$-----$-----$-----
$PNAUSCD,BaudRate Sensor3: 4800 CRC:auto
$PNAUSCD,Ignored:$HC---$-----$-----$-----
$PNAUSCD,          :$-----$-----$-----$-----
$PNAUSCD,----- Sensor Settings -----
$PNAUSCD,Analyze:
$PNAUSCD,Date      Src      Used      CHx      Update
$PNAUSCD,Position: Ext      $GPGLL  1          955ms
$PNAUSCD,UTC       : Int      $GPGGA  i          952ms
$PNAUSCD,Date      : Int      $GPRMC  i          951ms
$PNAUSCD,COG       : Ext      $VDVBW  1 Calc    952ms
$PNAUSCD,SOG       : Ext      $VDVBW  1 Calc    952ms
$PNAUSCD,Heading  : Ext      $TIHDT  1          953ms
$PNAUSCD,ROT       : Ext      $TIROT  1          949ms
$PNAUSCD,----- Sensor Settings -----
$PNAUSCD,Monitoring Sensor Channel 1
$PNAUSCD,[08:56:35,000] $TIROT,0.0,A
$PNAUSCD,[08:56:35,255] $GPGLL,5330.1234,N,01001
$PNAUSCD,.2345,E,141800.00,A,A
$PNAUSCD,[08:56:35,410] $GPVTG,350.0,T,,M,10.0,N
...
...
$PNAUSCD,[08:49:50,806] $TIHDT,359.9,T
$PNAUSCD,----- ROT : -----
$PNAUSCD,$TIROT ext. on Ch1 :ROT
$PNAUSCD,
$PNAUSCD,Sentence   : ROT      Talker : TI
$PNAUSCD,Update Rate: 949ms ChkSum : N/A
$PNAUSCD,Used Fields: 1,2
$PNAUSCD, 1:Rate Of Turn
$PNAUSCD, 2:Data Valid
$PNAUSCD,
$PNAUSCD,[08:49:52,900] $TIROT,0.0,A
$PNAUSCD,[08:49:51,950] $TIROT,0.0,A
$PNAUSCD,[08:49:51,001] $TIROT,0.0,A
$PNAUSCD,
$PNAUSCD,----- Sensor Settings -----

```

3.8.4 Sensor Monitoring for Problem Analysis

For specific information on a particular sensor, the NMEA input data can be monitored and is listed on the AIS display.

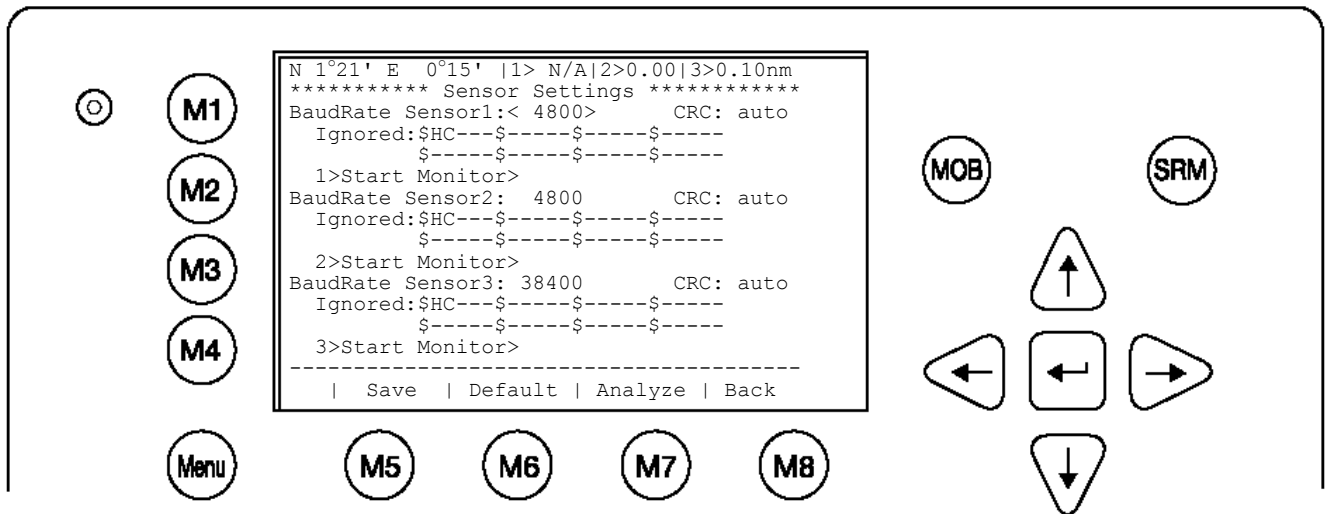

From the Sensor Configuration main screen one of the three sensor channels may be selected by pressing **1**, **2** or **3** or by using the cursor keys. By pressing the **right** cursor, the monitoring process is started.

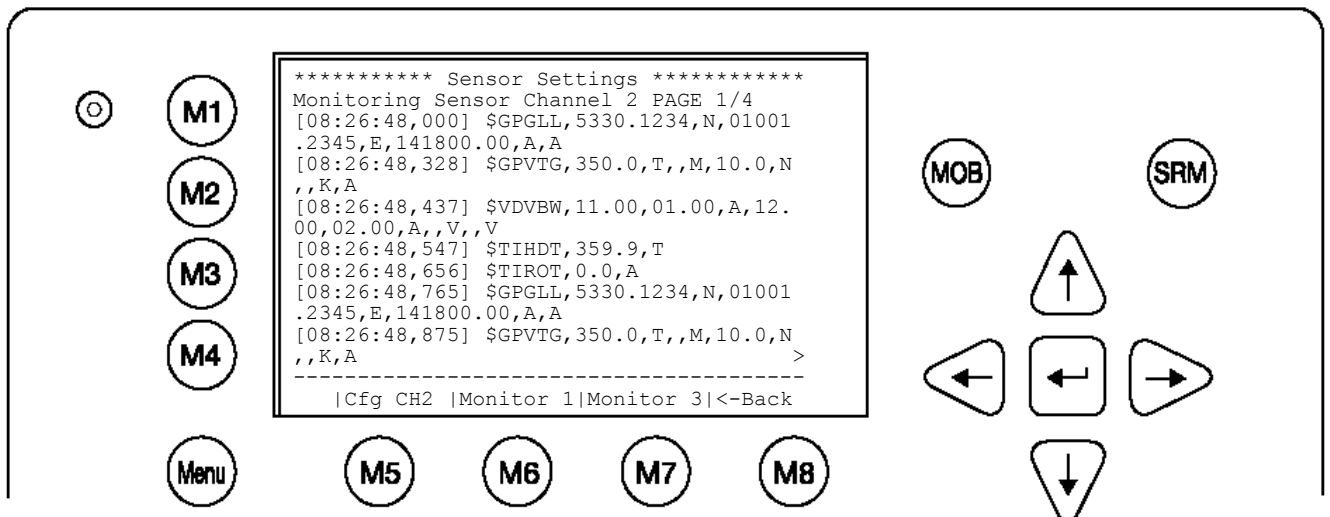

Complete NMEA sentence are shown. With **Monitor 2** [M6] or **Monitor 3** [M7] another sensor channel can be selected.

3.8.5 Priority Handling of Sensor Sentence

This table shows the priority handling of NMEA sentences. The sentences which are treated with higher priority are listed first.

Positioning System	Source	Priority
HIGH		
Time of Position		↓
Latitude/Longitude	GNS	
Position accuracy	GLL	
	GGA	
	RMC	
Rate of Turn(ROT)	ROT	
Reference Datum	DTM	
Speed over Ground	VBW	
	VTG	
	OSD	
	RMC	
Heading	HDT	
	OSD	
RAIM Indicator	GBS	↓
LOW		

3.8.6 Supported NMEA-0183 Sentences

DTM - Reference

```

      1   2 3   4 5   6 7   8   9
      |   | |   | |   | |   |   |
$--DTM,ccc,a,x.x,a,x.x,a,x.x,ccc*hh<CR><LF>

```

Field Numbers:

- 1) Local datum code (W84,W72,S85,P90,999-user defined, IHO datum code)
- 2) Local datum subdivision code
- 3) latitude offset, minutes
- 4) N or S (North or South)
- 5) longitude offset, minutes
- 6) E or W (East or West)
- 7) altitude offset, meters
- 8) Reference datum code ((W84,W72,S85,P90)
- 9) CRC

Used Fields: 1,8

- 1: Local datum code
- 8: Reference datum code

GGA - Positioning System Fix Data

Time, Position and fix related data form GPS receiver.

```

                                     11
      1           2           3 4           5 6 7 8   9 10 | 12 13 14 15
      |           |           | |           | | | |   |  | | | |
$--GGA,hhmmss.ss,llll.ll,a,yyyy.yy,a,x,xx,x.x,x.x,M,x.x,M,x.x,xxxx*hh

```

Field Numbers:

- 1) UTC
- 2) Latitude
- 3) N or S (North or South)
- 4) Longitude
- 5) E or W (East or West)

- 6) GPS Quality Indicator,
0 - fix not available,
1 - GPS fix,
2 - Differential GPS fix
- 7) Number of satellites in view, 00 - 12
- 8) Horizontal Dilution of precision
- 9) Antenna Altitude above/below mean-sea-level (geoid)
- 10) Units of antenna altitude, meters
- 11) Geoidal separation, the difference between the WGS-84 earth ellipsoid and mean-sea-level (geoid), \- \ means mean-sea-level below ellipsoid
- 12) Units of geoidal separation, meters
- 13) Age of differential GPS data, time in seconds since last SC104 type 1 or 9 update, null field when DGPS is not used
- 14) Differential reference station ID, 0000-1023
- 15) CRC

Used Fields: 1,2,3,4,5,6,7
 1:UTC 2:Lat 3:LaInd 4:Lon
 5:LoInd 6:Acc 7:Sat

GLL - Position - Latitude/Longitude

1	2 3	4 5	6 7 8

\$--GLL,llll.ll,a,yyyyy.yy,a,hmmss.ss,A,a*hh<CR><LF>

Field Numbers:

- 1) Latitude
- 2) N or S (North or South)
- 3) Longitude
- 4) E or W (East or West)
- 5) Universal Time Coordinated (UTC)
- 6) Status A - Data Valid, V - Data Invalid
- 7) Mode indicator
- 8) CRC

Used Fields: 1,2,3,4,5,6,7
 1:Lat 2:LaInd 3:Lon 4:LoInd
 5:UTC 6:Valid 7:Acc

GNS - Fix Data

1	2	3 4	5 6	7 8	9	10	11	12	13

\$--GNS,hmmss.ss,llll.ll,a,yyyyy.yy,a,c--c,xx,x.x,x.x,x.x,x.x,x.x,x.x*hh

Field Numbers:

- 1) UTC
- 2) Latitude
- 3) N or S (North or South)
- 4) Longitude
- 5) E or W (East or West)
- 6) Mode indicator
- 7) Total number of satellites in use,00-99
- 8) HDROP
- 9) Antenna altitude, meters, re:mean-sea-level(geoid)
- 10) Geoidal separation meters
- 11) Age of differential data
- 12) Differential reference station ID
- 13) CRC

Used Fields: 1,2,3,4,5,6,7
 1:UTC 2:Lat 3:LaInd 4:Lon

5:LoInd 6:Acc 7:Sat

RMC - Minimum Navigation Information

```

          1          2 3          4 5          6 7  8  9          10 11| 12 13
          |          | |          | |          | |  |  |          |  | | |
$--RMC,hhmmss.ss,A,llll.ll,a,yyyy.yy,a,x.x,x.x,ddmmyy,x.x,a,a*hh<CR><LF>
```

Field Numbers:

- 1) UTC Time
- 2) Status, V = Navigation receiver warning
- 3) Latitude
- 4) N or S
- 5) Longitude
- 6) E or W
- 7) Speed over ground, knots
- 8) Course over Ground, degrees true
- 9) Date, ddmmyy
- 10) Magnetic Variation, degrees
- 11) E or W
- 12) Mode Indicator
- 13) CRC

Used Fields: 1,2,3,4,5,6,7,8,9,10,11,12

1:UTC 2:Valid 3:Lat 4:LaInd 5:Lon 6:LoInd
7:SOG 8:COG 9:Date 10:MagV 11:MagIn 12:Acc

VBW - Ground/Water Speed

```

          1  2  3 4  5  6 7
          |  |  | |  |  | |
$--VBW,x.x,x.x,A,x.x,x.x,A*hh<CR><LF>
```

Field Numbers:

- 1) Longitudinal water speed, \- \ means astern
- 2) Transverse water speed, \- \ means port
- 3) Status, A = Data Valid
- 4) Longitudinal ground speed, \- \ means astern
- 5) Transverse ground speed, \- \ means port
- 6) Status, A = Data Valid
- 7) CRC

Used Fields: ,5,6

4:LonGS 5:TraGS 6:Valid

VTG - made good and Ground speed

```

          1  2 3  4 5  6 7  8 9 10
          |  | |  | |  | |  | | |
$--VTG,x.x,T,x.x,M,x.x,N,x.x,K,A*hh<CR><LF>
```

Field Numbers:

- 1) Track Degrees
- 2) T = True
- 3) Track Degrees
- 4) M = Magnetic
- 5) Speed Knots
- 6) N = Knots
- 7) Speed Kilometres per Hour
- 8) K = Kilometres per Hour
- 9) Status, A = Data Valid
- 10) CRC

Used Fields: 1,5,6,7,8,9
1:COG 5:SOG 6:SOGIn 7:SOG 8:SOGIn 9:Valid

OSD - Ship Data

```
      1   2 3   4 5   6 7   8   9 10  
      |   | |   | |   | |   |   | |  
$--OSD,x.x,A,x.x,a,x.x,a,x.x,x.x,a*hh<CR><LF>  
Field Numbers:
```

- 1) Heading, degrees true
- 2) Status, A = Data Valid
- 3) Vessel Course, degrees True
- 4) Course Reference
- 5) Vessel Speed
- 6) Speed Reference
- 7) Vessel Set, degrees True
- 8) Vessel drift (speed)
- 9) Speed Units
- 10) CRC

Used Fields: 1,2,3,4,5,6,9
1:HDT 2:HDTVal 3:COG 4:COGRef
5:SOG 6:SOGRef 9:SOGInd

HDT - True

```
      1   2 3  
      |   | |  
$--HDT,x.x,T*hh<CR><LF>
```

- Field Numbers:
- 1) Heading Degrees, true
 - 2) T = True
 - 3) CRC

Used Fields: 1,2
1:HDT 2:HDTRu

ROT - Of Turn

```
      1   2 3  
      |   | |  
$--ROT,x.x,A*hh<CR><LF>
```

- Field Numbers:
- 1) Rate Of Turn, degrees per minute, \- \ means bow turns to port
 - 2) Status, A means data is valid
 - 3) CRC

Used Fields: 1,2
1:ROT 2:Valid

3.8.7 Calculated Values

Processed dynamic ship data such as position, SOG etc. is generated by NMEA sentences.

Exceptions:

If "Calc" is displayed on the sensor analyze screen, this means that this sentence is used for calculating dynamic ship data.

ROT out of HDT

ROT direction left / right +/- will be calculated out of the HDT Message, if a TIROT sentence (only "TI"-Talker devices are valid) is not connected.

ROT > +10°/min	➔	Output +720°/min
ROT < -10°/min	➔	Output -720°/min
Other	➔	Output 0°/min

COG information out of VBW

COG will be generated out of VBW, if HDT is available. In this case the atan2 of the longitudinal and transversal speed plus heading is basis of the calculation.

Longitudinal/Transversal SOG from VBW

If VBW is available, SOG is also calculated without HDT.

3.8.8 Versions of NMEA Sentences

RMC

v2.30 - \$GPRMC,122500.00,A,5330.1234,N,01001.2345,E,11.2,352.2,120202,2.0,E,A
v2.20 - \$GPRMC,122500.00,A,5330.1234,N,01001.2345,E,11.2,352.2,120202,2.0,E

GLL

v2.30 - \$GPGLL,5330.1234,N,01001.2345,E,141800.00,A,A
v2.00 - \$GPGLL,5330.1234,N,01001.2345,E,141800.00,A
v1.50 - \$GPGLL,5330.1234,N,01001.2345,E

GGA

v2.00 - \$GPGGA,092854,5330.1234,N,01001.2345,E,1,3,1.2,65.2,M,45.1,M,,
v1.50 - \$GPGGA,092854,5330.1234,N,01001.2345,E,1,3,1.2,65.2,M,45.1,M

VBW

v2.30 - \$VDVBW,11.00,01.00,A,12.00,02.00,A,,V,,V
v2.20 - \$VDVBW,11.00,01.00,A,12.00,02.00,A

VTG

v2.30 - \$GPVTG,350.0,T,,M,10.0,N,,K,A
v2.20 - \$GPVTG,350.0,T,,M,10.0,N,,K

OSD

v2.30 - \$INOSD,359.9,A,5.2,B,12.6,B,150.0,1.2,N
v2.20 - \$INOSD,359.9,A,5.2,B,12.6,B,150.0

3.9 Pin-Description AIS-Cable / Socket 50-Pins:

TxA → out –
 TxB → out +
 RxA → in –
 RxB → in +

AIS Cable/Socket (Sub-D 50 Plug)					
1	CH5_out+			34	Spare
		18	Ch4_out+		
2	CH5_out-			35	Spare
		19	CH4_out-		
3	CH5_gnd			36	Spare
		20	CH4_gnd		
4	CH5_in+			37	Spare
		21	CH4_in+		
5	CH5_in-			38	Spare
		22	CH4_in-		
6	CH6_Vin			39	CH9_gnd
		23	CH8_in+		
7	CH6_gnd			40	CH9_out-
		24	CH8_in-		
8	CH6_CANL			41	CH9_in-
		25	CH8_gnd		
9	CH6_CANH			42	CH9_in+
		26	CH8_in+		
10	CH1_in-			43	CH9_out+
		27	CH8_in-		
11	CH1_gnd			44	Spare
		28	Spare		
12	CH1_in+			45	Spare
		29	CH3_in-		
13	CH2_in-			46	CH10_1
		30	CH3_gnd		
14	CH2_gnd			47	CH10_2
		31	CH3_in+		
15	CH2_in+			48	Vin_gnd
		32	Vin_gnd		
16	Vin+ (24V)			49	Vin_gnd
		33	Vin+ (24V)		
17	Vin+ (24V)			50	Spare
CH1	Sensor	CH4	ext. Display	CH8	Long Range
CH2	Sensor	CH5	aux. Display	CH9	DGNSS
CH3	Sensor	CH6	opt. 61162-3	CH10	BIIT / Relay (max. 30V DC / 1A)
Spare	Do not use				

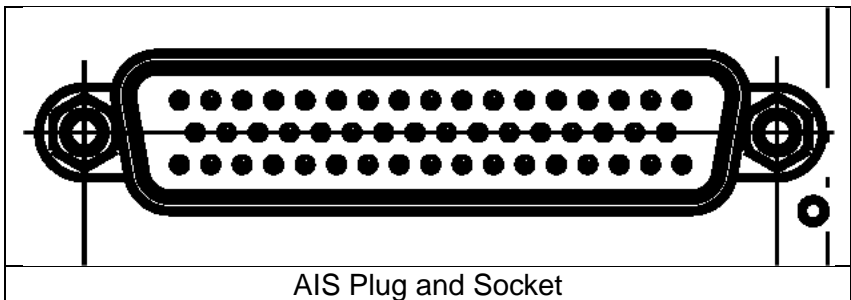

3.10 Pin-Description AIS-Connector:

Black BK
 White WH
 Red RD
 Green GN
 Brown BR
 Blue BL
 Orange OR
 Yellow YL
 Violet VI
 Gray SL(Slate)
 Pink PK

AIS -Cable Sub-D 50 Plug

Note:
 TxA → out -
 TxB → out +
 RxA → in -
 RxB → in +

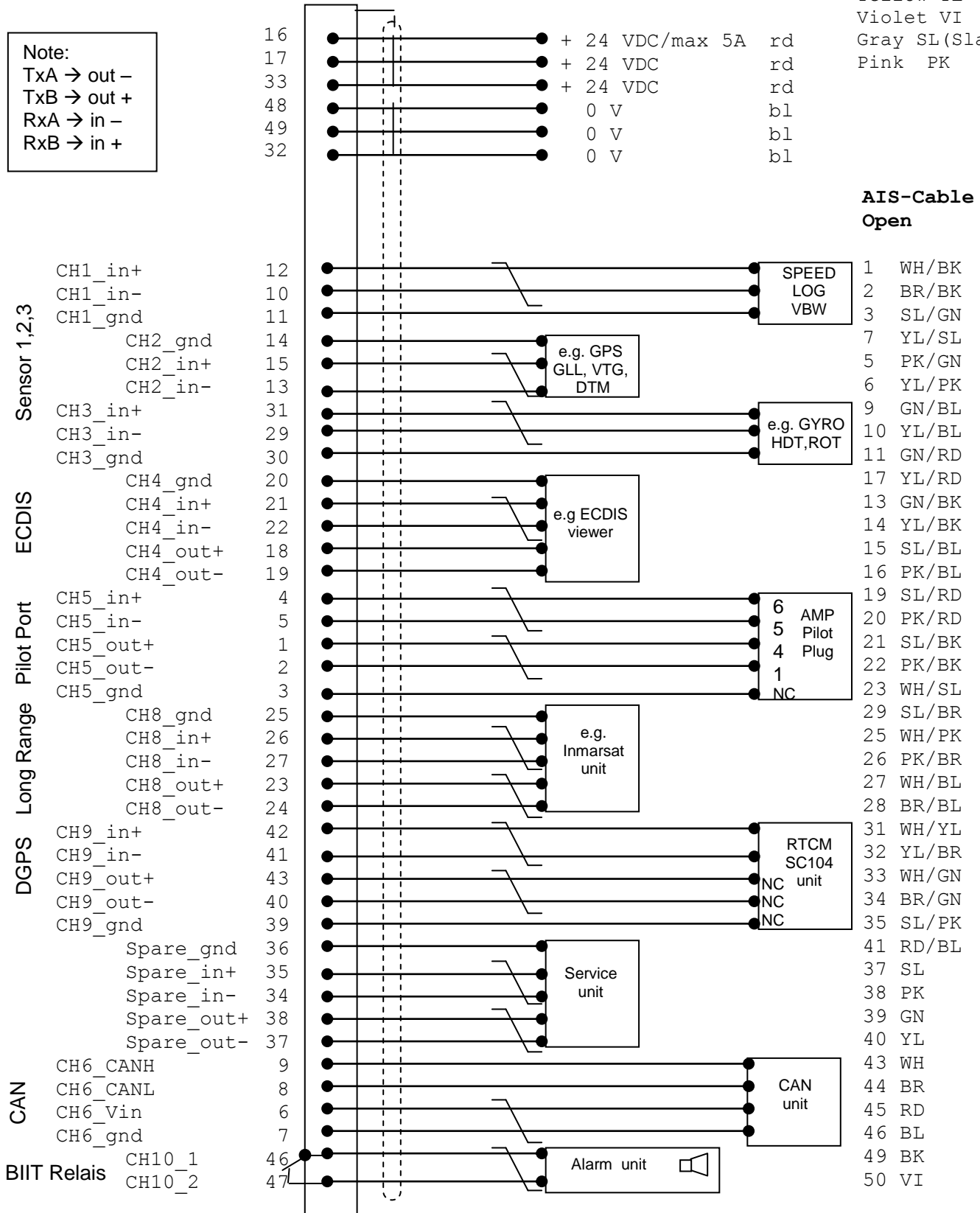

AIS-Cable Open

1	WH/BK
2	BR/BK
3	SL/GN
7	YL/SL
5	PK/GN
6	YL/PK
9	GN/BL
10	YL/BL
11	GN/RD
17	YL/RD
13	GN/BK
14	YL/BK
15	SL/BL
16	PK/BL
19	SL/RD
20	PK/RD
21	SL/BK
22	PK/BK
23	WH/SL
29	SL/BR
25	WH/PK
26	PK/BR
27	WH/BL
28	BR/BL
31	WH/YL
32	YL/BR
33	WH/GN
34	BR/GN
35	SL/PK
41	RD/BL
37	SL
38	PK
39	GN
40	YL
43	WH
44	BR
45	RD
46	BL
49	BK
50	VI

3.11 Pin-Description Communication-Cable / Socket 50-Pins

Communication-Cable / Socket (Sub-D 50 Socket)					
1				34	
		18			
2				35	
		19			
3				36	
		20			
4				37	
		21			
5				38	
		22			
6				39	
		23			
7				40	
		24			
8				41	
		25			
9				42	
		26			
10				43	
		27			
11				44	Blue Sign - Switch
		28	Blue Sign - Switch		
12				45	
		29			
13				46	
		30			
14				47	
		31			
15	CH15_TxD			48	
		32	CH15_RxD		
16				49	CH15_GND
		33			
17				50	
CH15	Communication RS232				
Spare	Do not use				

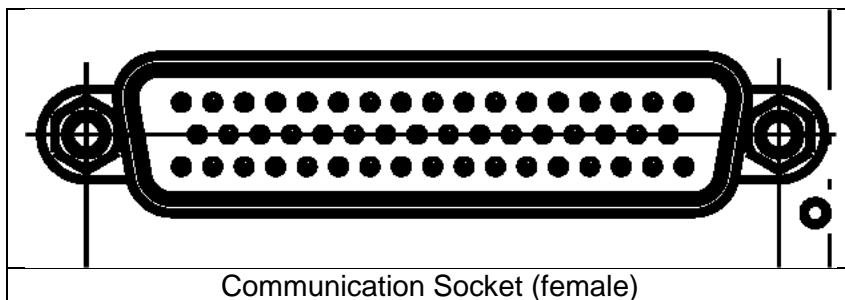

3.12 Communication Cable RS232 (Sub-D 50 Socket)

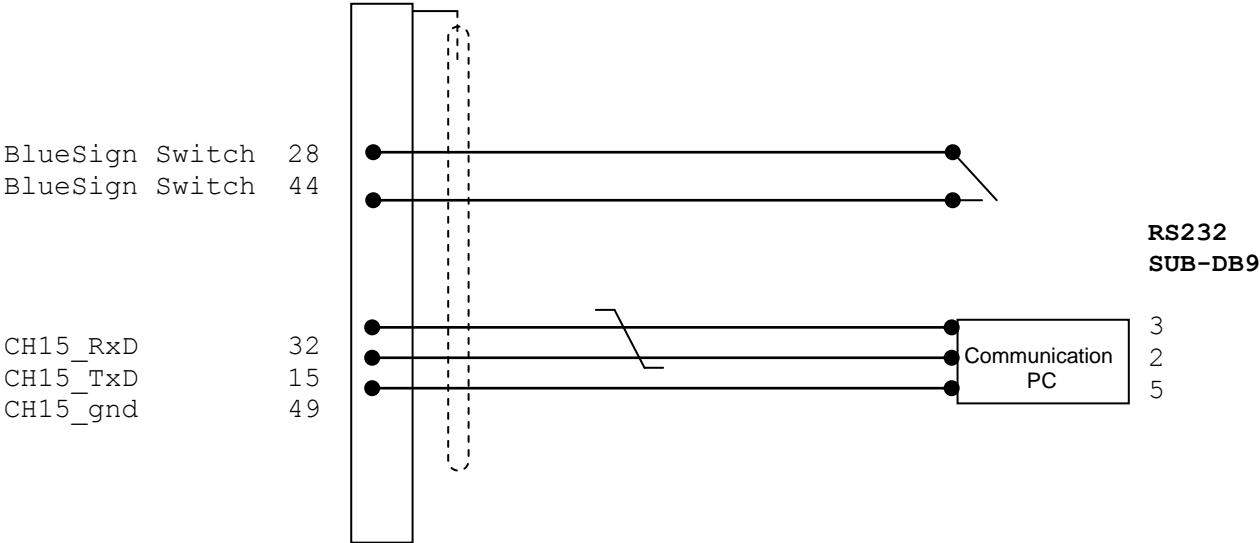

Cable 2635 (NAU-B502) includes blue sign connction and RS232..

3.13 Installation of VHF / GPS Antennas

Interference to the Ship's VHF Radiotelephone

The AIS ship borne equipment, like any other ship borne transceiver operating in the VHF maritime band, may cause interference to a ship's VHF radiotelephone. Because AIS is a digital system, this interference may occur as a periodic (e.g. every 20 seconds) soft clicking sound on the ship's radiotelephone. This affect may become more noticeable if the VHF radiotelephone antenna is located close to the AIS VHF antenna, and when the radiotelephone is operating on channels near the AIS operating channels (e.g. channels 27, 28 and 86).

Attention should be paid to the location and installation of the various antennas, in order to support the antenna characteristics in the best possible way.

3.13.1 VHF Antenna Installation

Antenna Location

Location of the mandatory AIS VHF-antenna should be carefully considered. Digital communication is more sensitive than analogue/voice communication to interference created by reflections caused by obstructions such as masts and booms. It may be necessary to relocate the VHF radiotelephone antenna to minimize interference effects.

To minimize the interference effects, the following guidelines apply:

- The AIS VHF antenna should have omni directional vertical polarization providing 3 to 5 dB gain.
- The AIS VHF antenna should be placed in an elevated position, as free standing as possible, with a minimum of 2 meters in horizontal direction from constructions made of conductive materials. The antenna should not be installed close to any large vertical obstruction. The AIS VHF antenna should have a visible sky of 360°.
- The AIS VHF antenna should be installed at least 3 meters away from interfering high-power energy sources such as radar and other transmitting radio antennas, and out of the way of the transmitting beam.
- There should not be more than one antenna on each level. The AIS VHF antenna should be mounted directly above or below the ship's primary VHF radiotelephone antenna, with no horizontal separation and a minimum of 2 meters vertical separation. If it is located on the same level as other antennas, the distance apart should measure at least 10 meters.

See also sample for antenna layout in the Appendix (Drawings and Approvals)

Cabling

The cable should be kept as short as possible to minimize attenuation of the signal. Double shielded coaxial cables equal to or better than RG214 is recommended. RG214 at VHF attenuation per meter of app. 0,07 dB/m (45m = 3,15db)
VHF AIS frequency app. 162MHz

All outdoor connectors on the coaxial cables should be fitted with preventive isolation, such as shrink-stocking with silicone to protect the antenna cable against water penetration. Coaxial cables should be installed in separate signal cable channels/tubes, and at least 10 cm away from any power supply cables. Crossing of cables should take place at right angles (90°). Coaxial cables should not be exposed to sharp bends, which may lead to changes to the characteristic impedance of the cable. The minimum bend radius should be 5 times the cables outside diameter.

Grounding

Coaxial down-leads must be used for all receiving antennas, and the coaxial screen should be connected to the ground at one end.

3.13.2 GNSS Antenna installation

A Class A AIS must be connected to a GNSS antenna.

Location

The GNSS antenna must be installed where it has a clear view of the sky, so that it accesses the horizon freely through 360°, with a vertical observation of 5 to 90 degrees above the horizon. Small diameter obstructions, such as masts and booms, do not seriously impair signal reception, but such objects must not eclipse more than a few degrees of any given bearing.

The antenna must be located at least three meters away from, and out of the transmitting beam of high-power transmitters (S-Band Radar and/or Inmarsat systems). This includes the ship's own AIS VHF antenna, if it is designed and installed separately. See also sample for antenna layout in Installation Manual Appendix 8.2 (Drawings)

If a DGNSS system is included or connected to the AIS system, the installation of the antenna should be undertaken in accordance with IEC 61108-4, Edition 1.

Cabling

To achieve optimum performance, the gain of the antenna pre-amplifier should match the cable attenuation. The resulting installation gain (pre-amplifier gain - cable attenuation) should be within 0 to 10 dB (RG214 at GPS attenuation per meter of app. 0.35 dB/m (45m = 15.75dB); GPS frequency app. 1.2GHz).

The coaxial cable between the antenna and the AIS ship borne station connector should be routed directly, in order to reduce electromagnetic interference. The cable should not be installed close to high-power lines, such as radar or radio-transmitter lines, or near the AIS VHF antenna cable. A space of one meter or more is recommended in order to avoid degradation due to RF-coupling. Crossing of antenna cables should take place at 90 degrees, to minimize magnetic field coupling.

Attenuation

As described above, the resulting installation gain should be between 0 to 10 dB. If the internal GPS receiver will be overloaded with more than 18 dB, then it could be damaged.

Attenuation values

Type	Name	Part number	Total gain
GPS-Antenna	GPS-Antenna Marina 2	2625	+35dBi
GPS-Antenna	Procom GPS4	2622	+35dBi
Comb. GPS/VHF-Antenna	Comrod AC-17	2624	+20dBi (GPS amp gain)
Cable	RG214	2630	-15.75 dB
Adapter	GPS-VHF Adapter cable with 1m RG58 / TNC connector	2612	-1dB
Connector	TNC plug RG214 crimp	2633	-0.1dB

Example

Procom GPS4	+ 35.00dBi
11m RG214 0,35 dB/m	- 3.85dB
maybe 2 TNC plugs	- 0.20dB
Nauticast with Adapter P/N 2610	-1.00dB
Total	29.95dB
Necessary minimum attenuation (=> 12dB Attenuator needed!)	≥11.95dB
GPS Input	≤18.00dB

Attention

If installations are not in compliance to this requirement we cannot guarantee operation nor accept a warranty issue.

Antenna Layout

The position of the VHF and GNSS – antennas must be added to the existing antenna layout of the vessel.

3.14 Power Supply

The NAUTICAST must be supplied from the emergency power source. A new battery capacity calculation must be undertaken. See sample in 9.1 (Samples for battery calculation)

Following documents are needed for the installation approval of the classification

- Antenna Layout (arrangement)
- Battery Calculation
- Connection / Block – Diagram with locations
- Type Approval Certificate

4 Starting the NAUTICAST

4.1 Initial Set Up of the NAUTICAST for operation

ATTENTION: AUTHORITIES MANADATE THAT YOU ENTER THIS INFORMATION.

After installing the antennas and hardware the following User, Voyage related and Ship Settings data needs to be entered. Upon Start-up (Applying power) enter the following information.

- a) Enter MMSI Number - See paragraph 4.2 on entering information.
During the initial boot or after “factory settings” the user is asked to enter a valid MMSI number. As long as this is not done, the system does not transmit. This appears as Alarm-ID 56 with the text “AIS: ENTER MMSI NUMBER”.

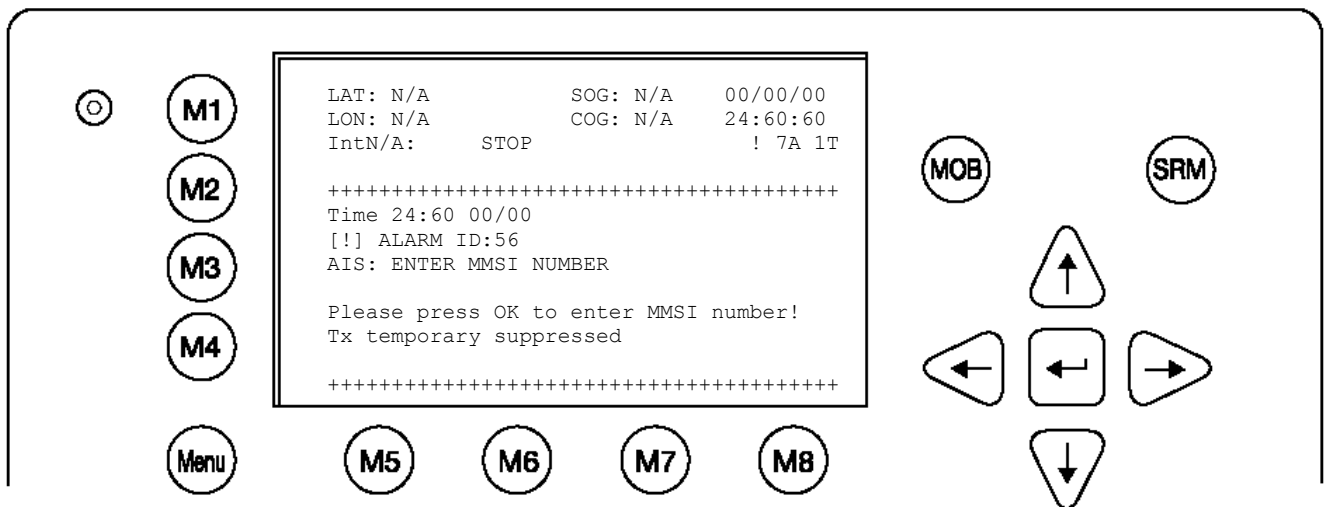

- b) Enter IMO Number, Designated Area Code (DAC) and European Ship Number (ESN) - See paragraph 4.2 on Entering information.
- c) Select AIS Mode – According to the local requirements you have to select the AIS Mode between Inland AIS or SOLAS AIS.
See paragraph on altering this information.
- d) Ship Settings Data - After initial entry of the Ship Settings Data any changes in the information below should be edited accordingly. See Paragraph 4.3 on entering information.
- Enter Call Sign
 - Enter Ships Name
 - Enter Length of Ship
 - Enter Beam of Ship
 - Enter Internal GPS antenna Position
 - Enter External GPS Antenna Position (If Applicable).
 - Enter Ship Type
- e) Voyage related Data – After initial entry of the Voyage related Data any changes in the information below should be edited accordingly.
See Paragraph 4.4 on entering information.
- Enter Cargo Type
 - Enter Draught
 - Enter Destination
 - Enter ETA
 - Enter Navigation Status.
- f) Password – Service and User passwords see section 4.6 or see the appendix in your User Manual for password information.

4.2 Entering the MMSI / IMO / DAC / ESN Numbers

Select from the Main Menu **“Service Configuration”** Number 6. This option requires the SERVICE password. The default password from the factory is mentioned on your AIS display at the protection foil. Please see the appendix in your User Manual for additional password information. Enter Service Password and use the up and down arrows on keypad to select “Change MMSI / IMO” than press M5 “Select” or “by pressing number 3 on the keypad. Input your MMSI and IMO number and press Save to store data. Unit will reboot itself after pressing Save. Continue to 4.2 after reboot.

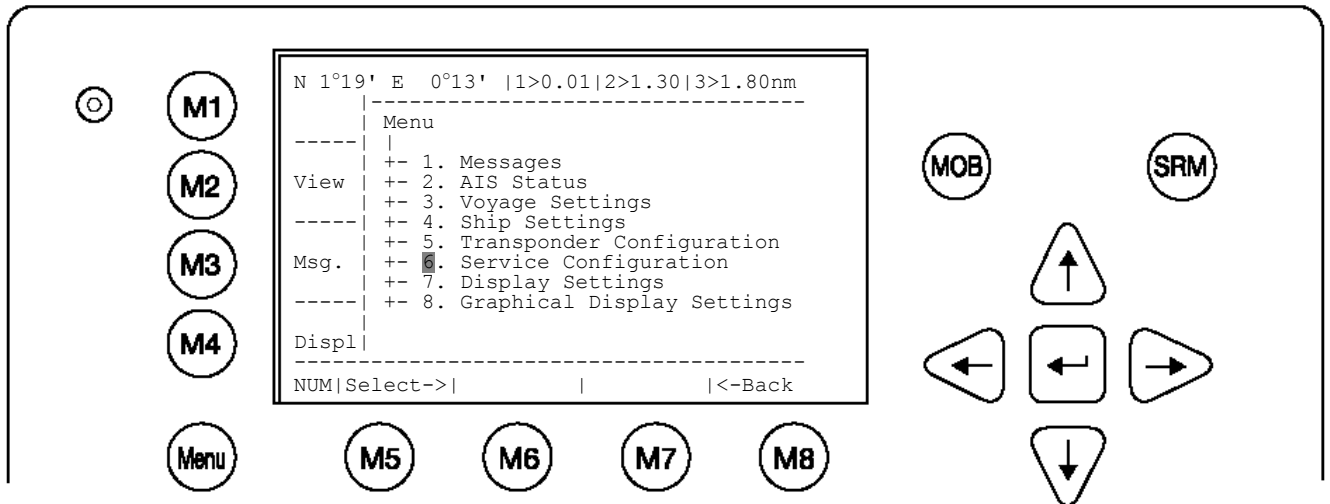

Service Configuration Menu Example:

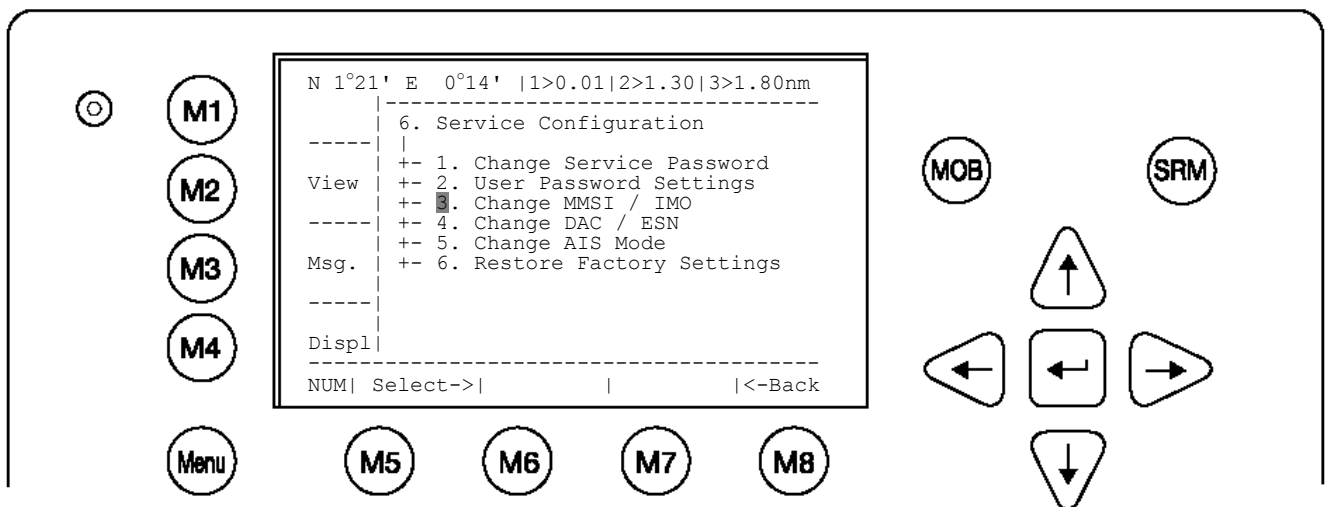

Note: MMSI and IMO Data input are limited to 9 characters.

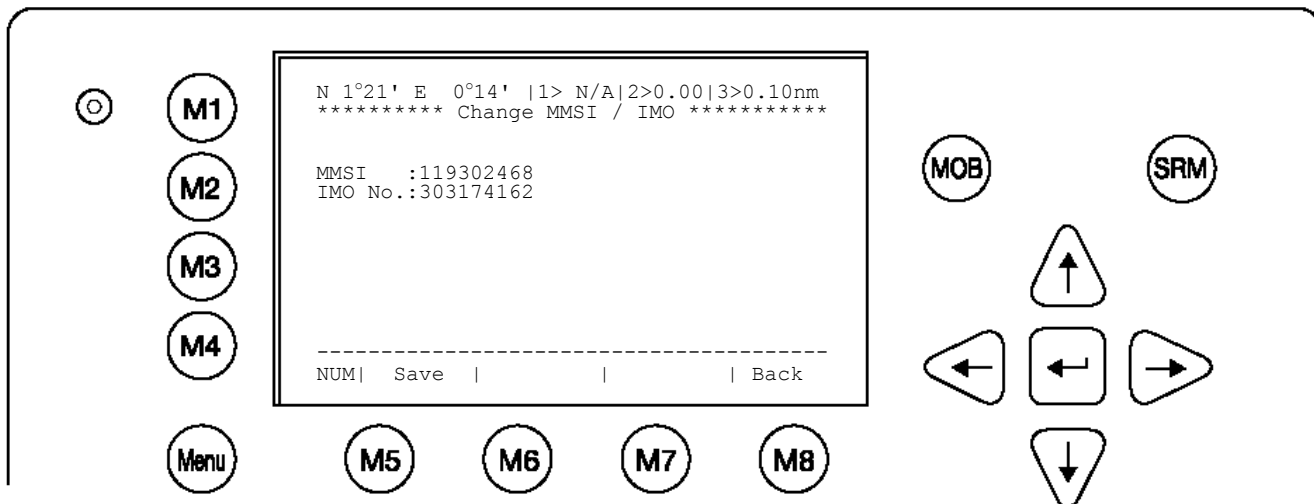

Select Submenu 4 “Change DAC / ESN” with cursor button [Up] & [Down] by pressing Nr. 4 on the keyboard.

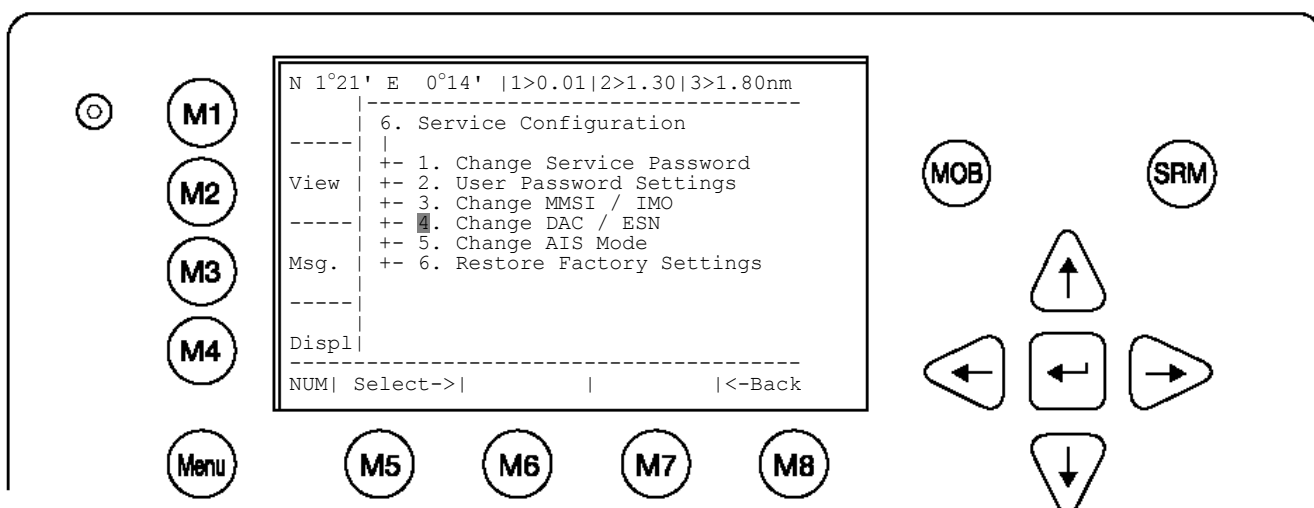

Input new DAC / ESN Numbers and press [Save] to store input data. Press [Back] to return to the Submenu without saving.

Note:

The DAC (Designated Area Code) is predefined with the value “200”. Please key in only a different 3 digit value if your authority wants you to do this. Otherwise you may lose important AIS information. The ESN (European Ship Number) is limited to 8 ASCII characters.

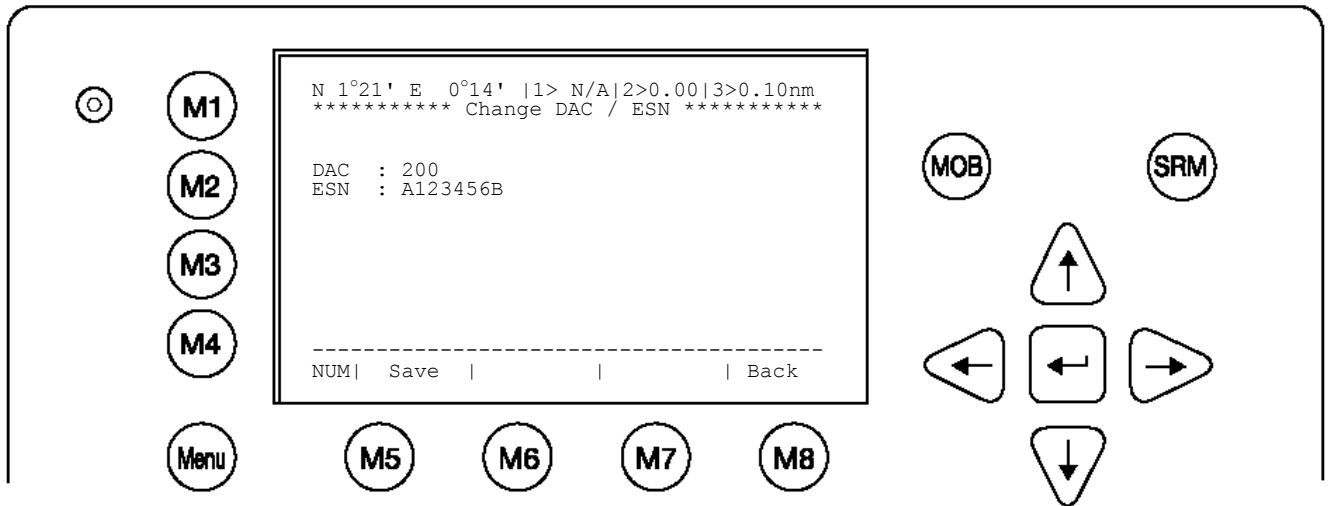

4.3 Entering Ship Settings

Select from the Main Menu “4. Ship Settings” This option requires the USER password. The default password from the factory is mentioned on your AIS display at the protection foil. Please see the appendix in your User Manual for additional password information. Enter Password and use the up and down arrows to edit Ship Settings then press Enter or the numeric reference on the keypad to select and edit. Save after editing.

Main Menu Example:

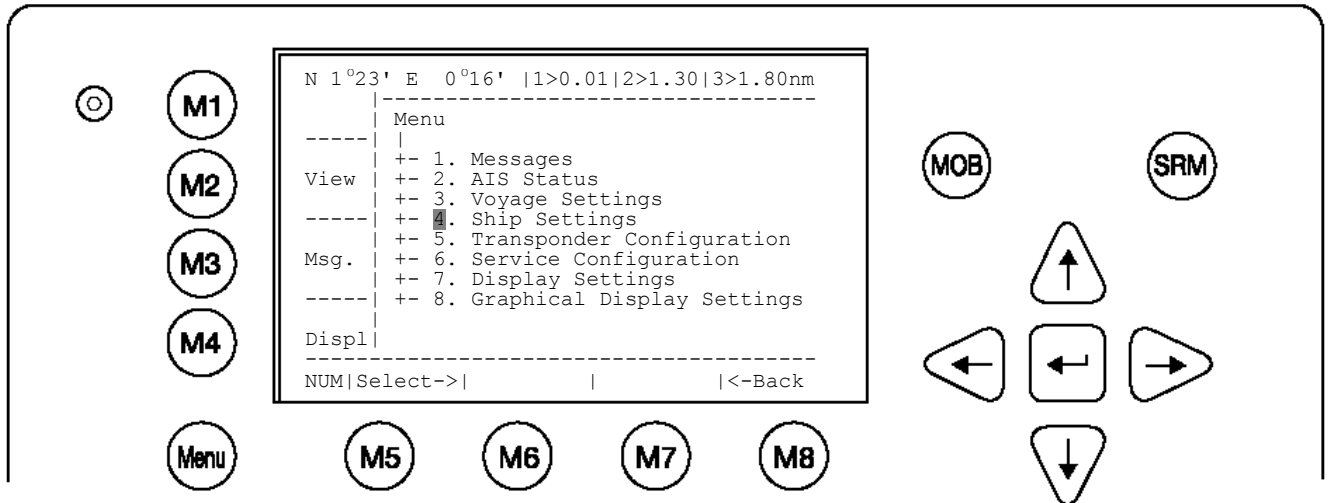

Select Ship Settings and press M5 [Enter]. Enter User Password and Continue.

Ship Settings Menu Example:

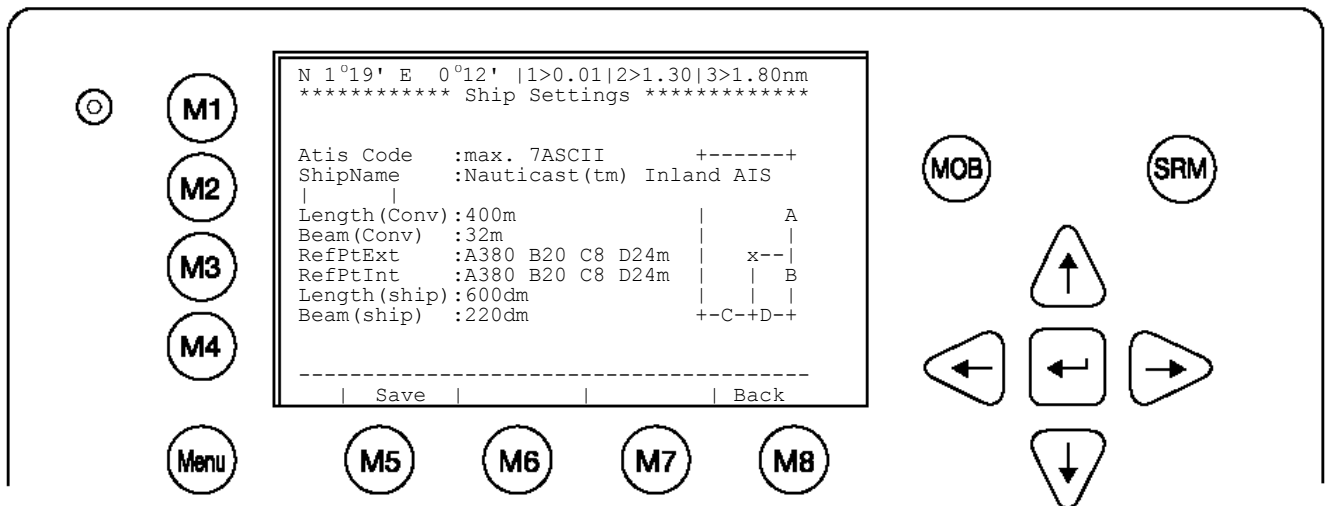

- Select and enter ATIS Code / Call Sign.
- Select and enter Ship Name.
- Select and enter Length of Convoy (in m).
- Select and enter Beam of Convoy (in m).
- Select and enter Internal and External GPS antenna positions.
- Select and enter Length of Ship (in dm).
- Select and enter Beam of Ship (in dm).

Setting the Internal and External GPS Antenna Position.

Note: It is critical for the proper orientation of your ship to other AIS users to enter this data accurately.

Example: Length of ship = 220m and Beam = 43m.

GPS ANTENNA location on ship (is x in above Menu example) is located 200 meters from bow (A) and 33 Meters from Starboard side (D).

Note: You can only enter Dimension A and D. B and C are automatically calculated.

You would enter A200D33 (without spaces, no decimals and no commas).

Then Press Save.

The line than should look like the example above for External Reference point.

Note: When only using internal GPS antenna it is ok to have default values for external position since they are not used.

RefPointExt = A200 B20 C10 D33m (Position of the external GPS antenna)

A = the distance from bow (front) to the antenna.

B= the distance from the antenna to the stern (rear)

C = the distance from the port (left) side to the antenna

D = the distance from the antenna to the starboard (right) side

Enter RefPtInt (location of the internal GPS antenna) in the same way.

Save the new settings by pressing [Save].

Press [Back] return to the Main Menu Screen without saving any changes.

4.4 Entering Voyage Related Data

Select from the Main Menu “3. Voyage Settings” This option requires the USER password. The default password from the factory is mentioned on your AIS display at the protection foil. Please see the appendix in your User Manual for additional password information. Enter Password and use the up and down arrows to edit Voyage Related data then press Enter or the numeric reference on the keypad to select and edit. Save after editing.

Main Menu Example:

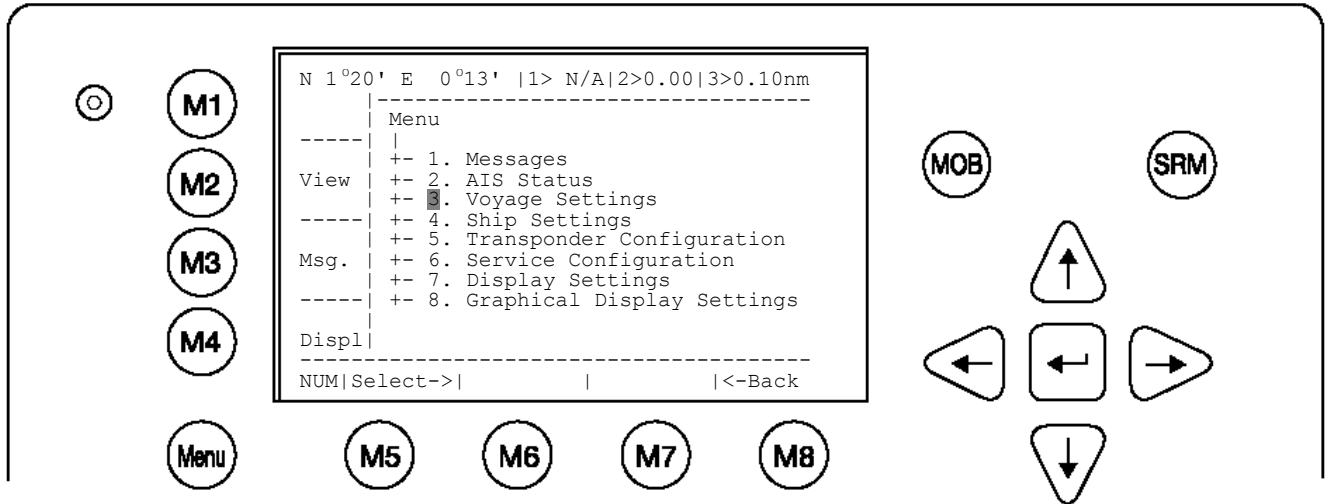

The password query field appears. Input new User Password and press [Enter].

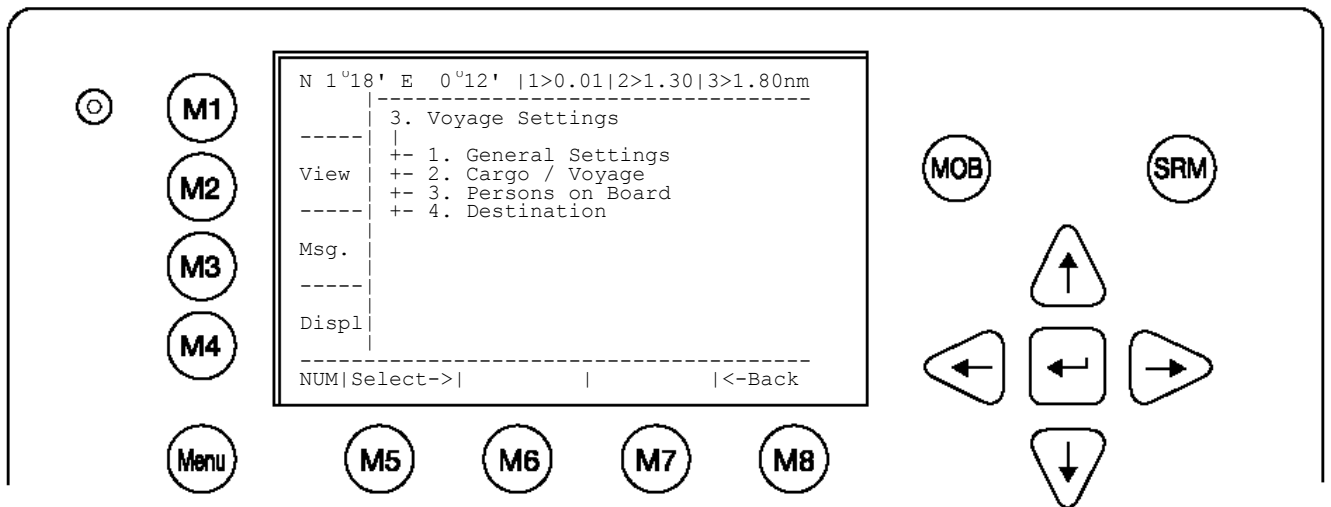
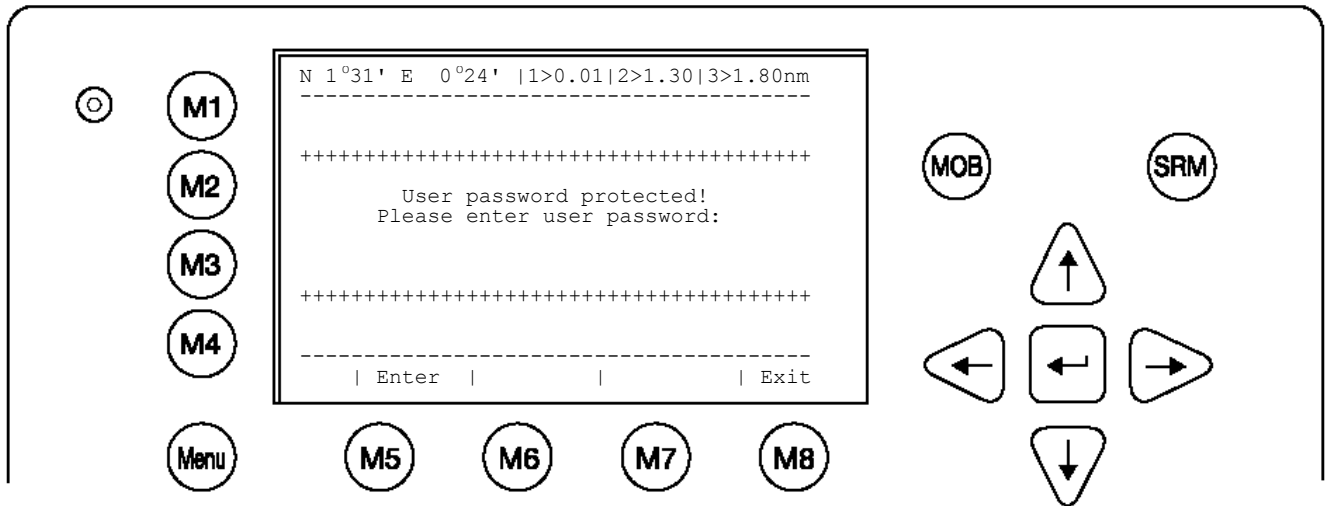

Select Submenu 1 “General Settings” with cursor button [Up] & [Down] by pressing Nr. 1 on the keyboard.

Scroll the Data Fields with [Enter] and input own vessel data. Enter draught in meter (max. = 20.0m), and air-draught value in centimetre (max. = 4000cm) as well as the correct navigational status setting. Running AIS in high sea mode allows draught of 25.5m

Save the new settings by pressing [Save], and return to the Main Menu Screen by pressing [Exit]. Press [Back] to return to the Main Menu without saving any changes.

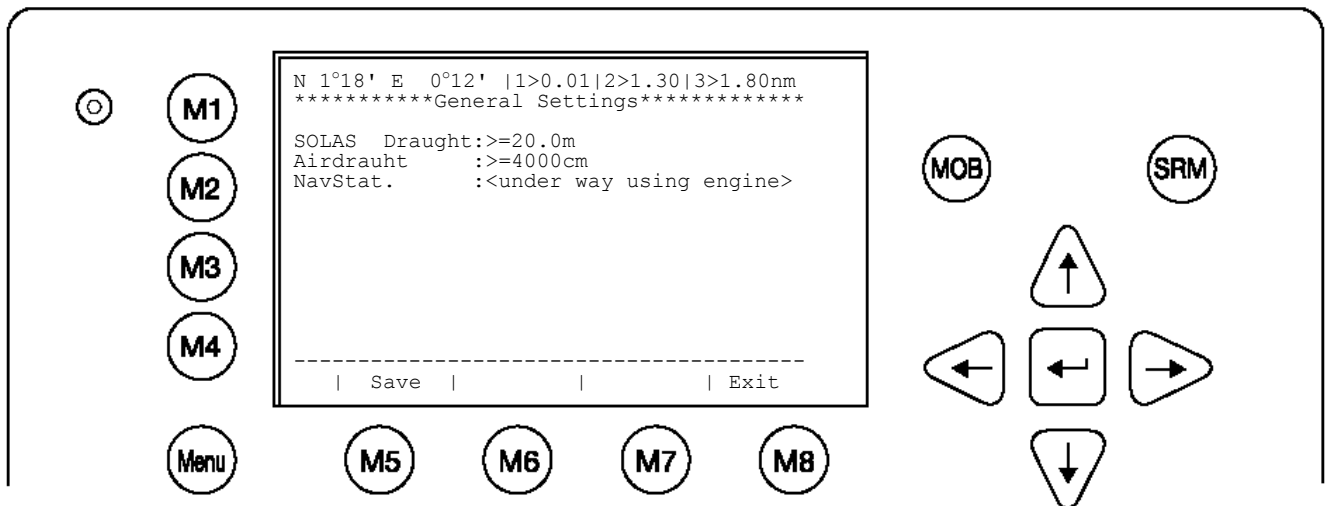

Select Submenu 2 “Cargo/Voyage Settings” with cursor button [Up] & [Down] or by pressing Nr. 2 on the keyboard.

Toggle the values for the **ERI ship type** (see section 7.1), the hazardous cargo by the number of **Blue Cones** [0-3, B-Flag, Default/Unknown], and the loaded / unloaded status **Un/Loaded** [Loaded, Unloaded].

Save the new settings by pressing [Save], and return to the Main Menu Screen by pressing [Exit]. The ERI ship types, which are used in Inland message 10, are automatically converted to the IMO types which are used in IMO message 5 (refer to section 7.1.). Press [Back] to return to the Main Menu without saving any changes.

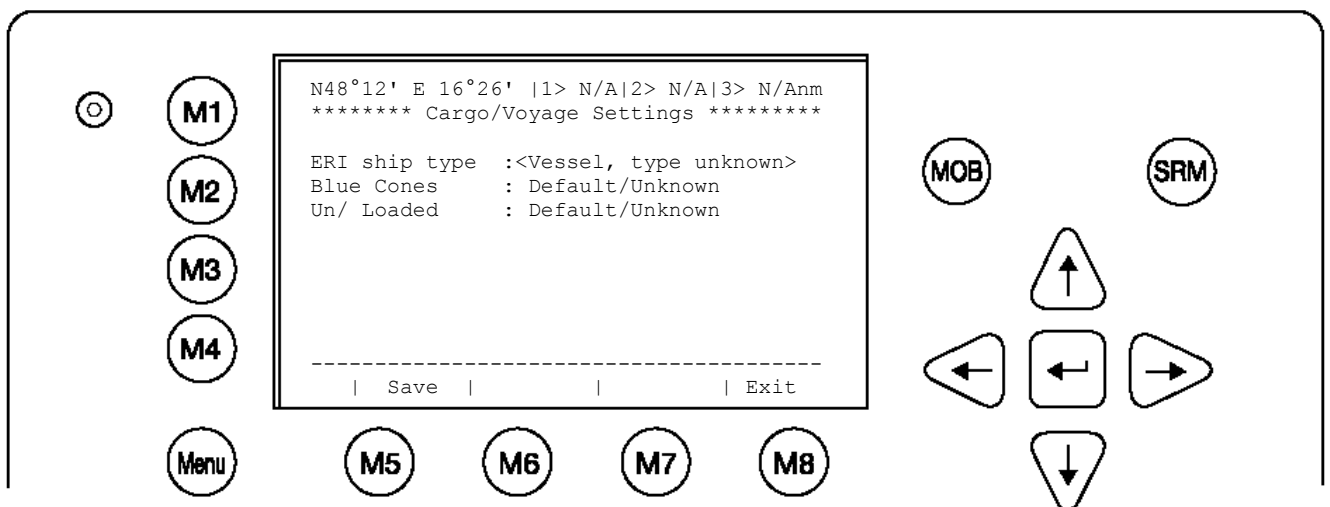

Select Submenu 3 “Persons on Board” with cursor button [Up] & [Down] or by pressing Nr. 2 on the keyboard.

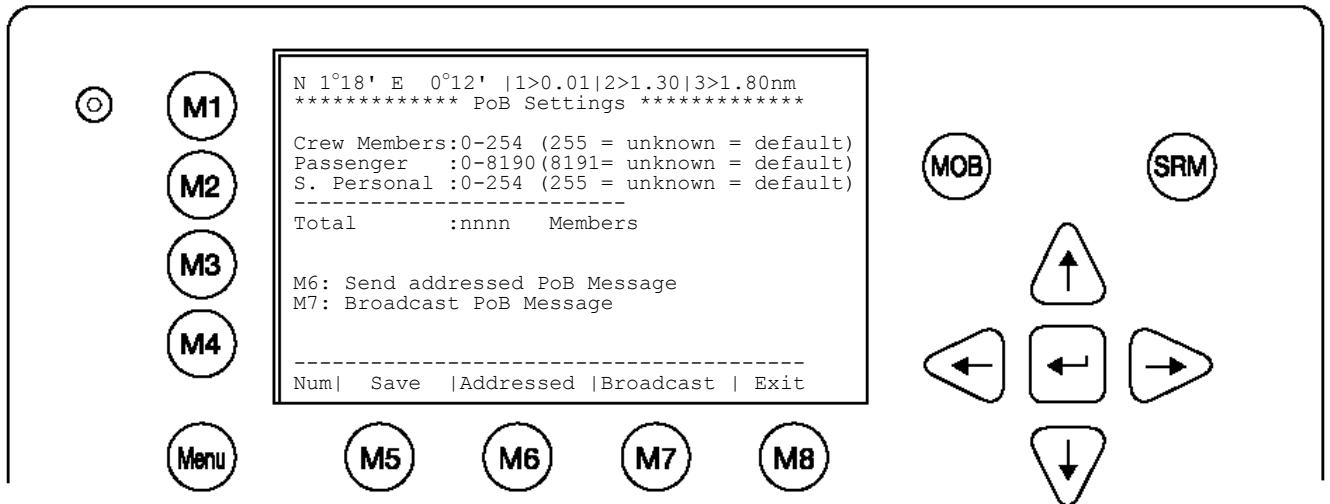

Note:

The total number of persons on board will be calculated automatically. In “High Seas” mode this sum will be used for the AIS messages.

How to use this menu to transfer PoB – information will be described in detail in the User Manual.

Select Submenu 4 “Destination” with cursor button [Up] & [Down] by pressing Nr. 4 on the keyboard.

Select between mask input and direct input of the destination string.

Mask input:

Scroll the Data Fields with [Enter] and input the UN destination codes as well as the ETA (estimated time of arrival) data.

Save the new settings by pressing [Save], and return to the Main Menu Screen by pressing [Exit]. Press [Back] to return to the Main Menu without saving any changes.

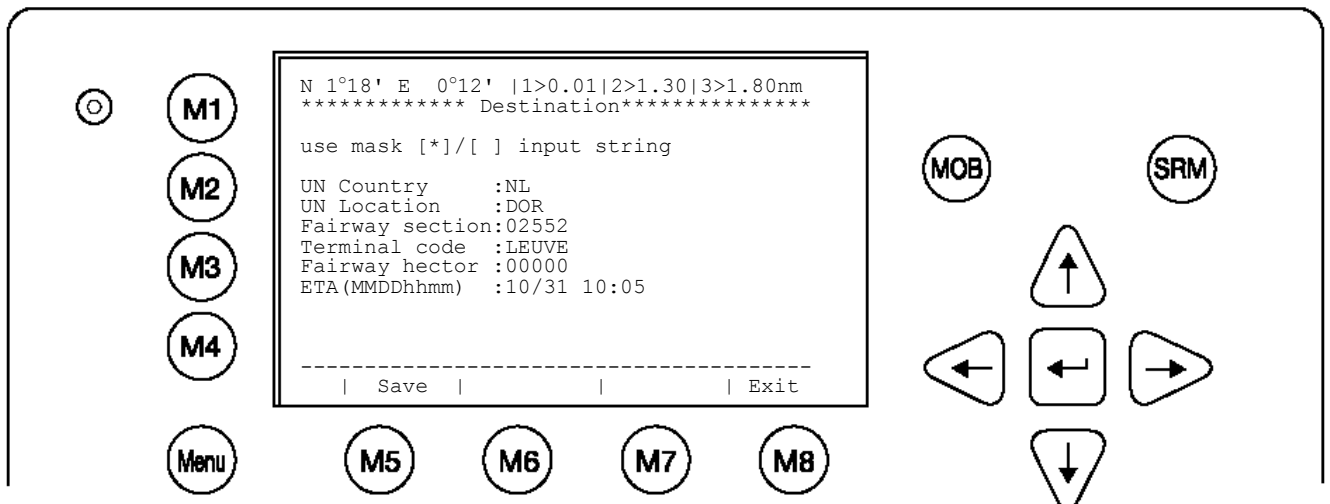

String Input:

Direct input of all entries above as string.

NOTE: All characters are allowed. Its in the users responsibility to enter the correct length for all entries. The above mask would be entered as:

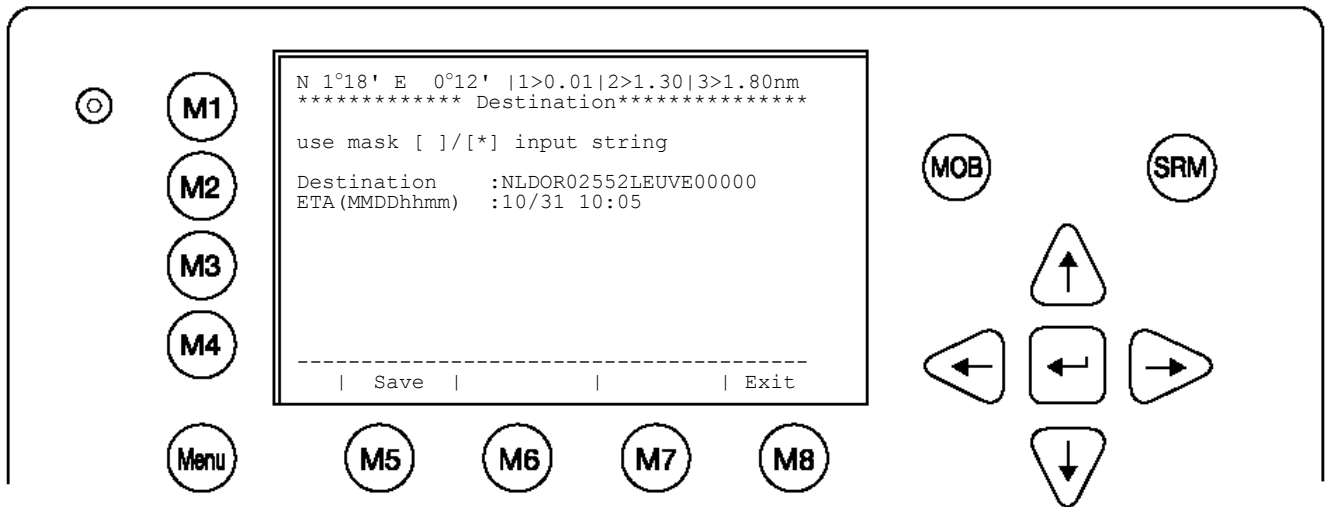

The ETA must be entered separately in the according field.

4.5 Entering Inland AIS Configuration

Select from the Main Menu "5. Transponder Configuration" This option requires the USER password. The default password from the factory is mentioned on your AIS display at the protection foil. Please see the appendix in your User Manual for additional password information. Enter User Password and press [Enter] or [M5].

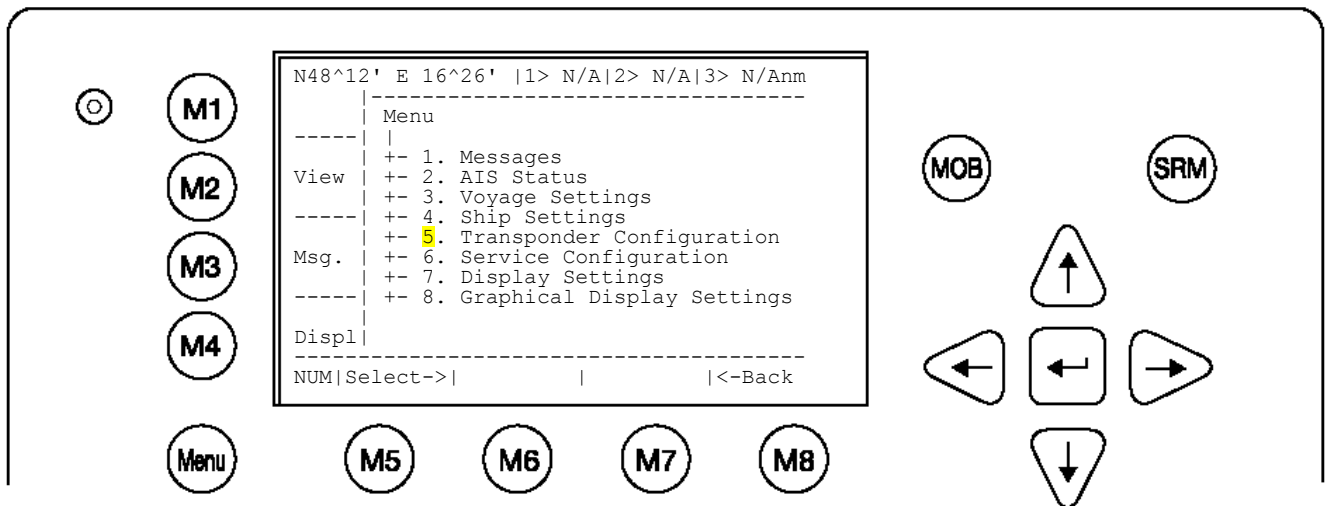

Select Submenu 7 “Inland AIS Configuration” with cursor button [Up] & [Down] by pressing Nr. 7 on the keyboard.

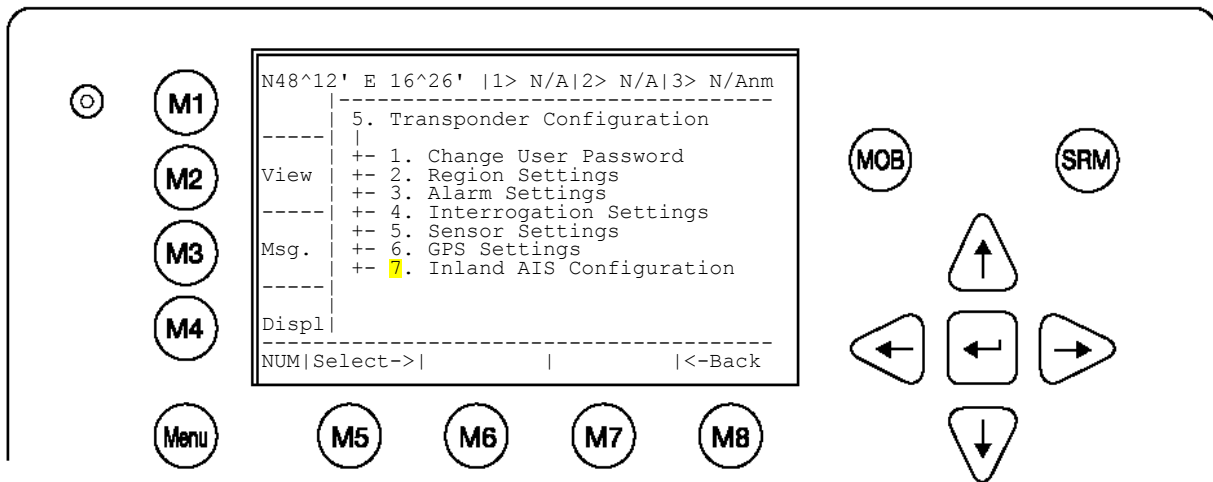

This screen allows the user to toggle the quality of the speed, course or heading information received from an external device. These settings are normally set to low.

Note: It is highly recommended to keep the settings to low.

Blue Sign:

Toggle the value from <not available> to <used> when a Blue Sign switch is connected. Setting the blue sign can be done by an external hardware switch. Please see the chapter 3.12 how to connect the blue sign - cable 2635 (NAU-B502) which includes and RS232 connector as well. Unless you configure the Blue Sign appropriate, you may not be able to use it.

BlueSign	Blue Sign	<not available> no blue sign switch is connected <used> when a blue sign switch is connected
-----------------	-----------	---

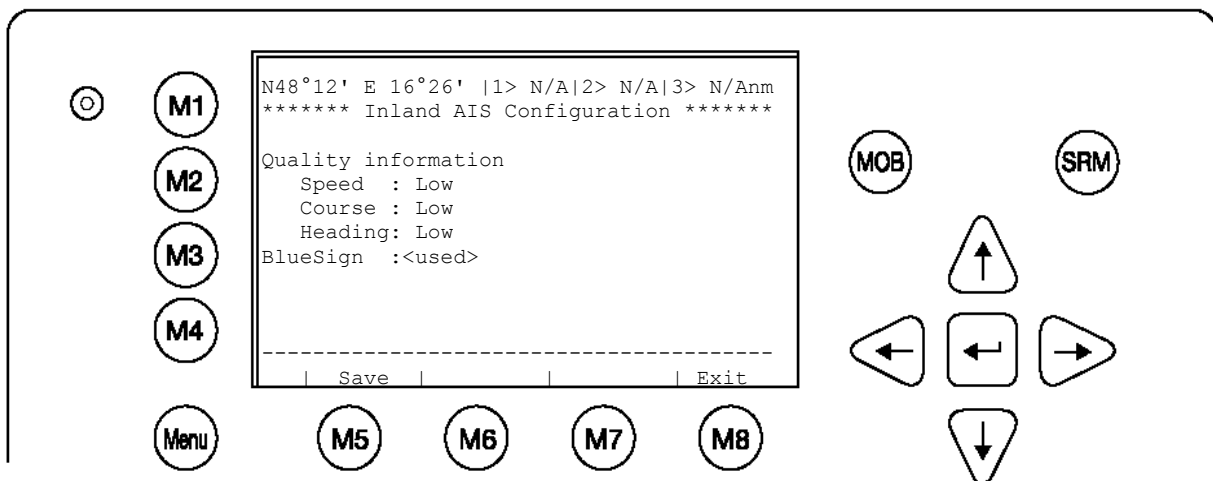

4.6 Service and User Passwords

⚠ WARNING: It is very important that the Service password not be lost. Keeping the password in a second location may be wise. Record your custom service and user passwords in the table provided in the appendix of your User Manual. Memorizing the password is best. If you lose this password, you cannot make any further configuration changes: Access to the AIS is blocked. Another master key is not available and the unit would have to be returned to the ACR Service centre. This service is not free of charge.

Once you have entered the system, please change the default password to your own passwords, for both levels of access. Use different passwords for the different security levels. Your passwords must meet the following criteria:

- Minimum of six (6) characters, maximum of eight (8) characters
- Letters must be in UPPER CASE
- Acceptable characters are the A-Z alphabet and 0- 9 digits
- Password may contain both letters and numbers

The User Password can be reset in the service configuration menu by entering the Service Configuration menu and creating a new password.

Changing the Service Password

Select “Service Configuration” from the Main Menu with the cursor button [Up] & [Down] or press Number 6 on the keyboard.

The password query field appears. Input default Service Password and press M5 [Enter]. The default password from the factory is mentioned on your AIS display at the protection foil. Please see the appendix in your User Manual for additional password information.

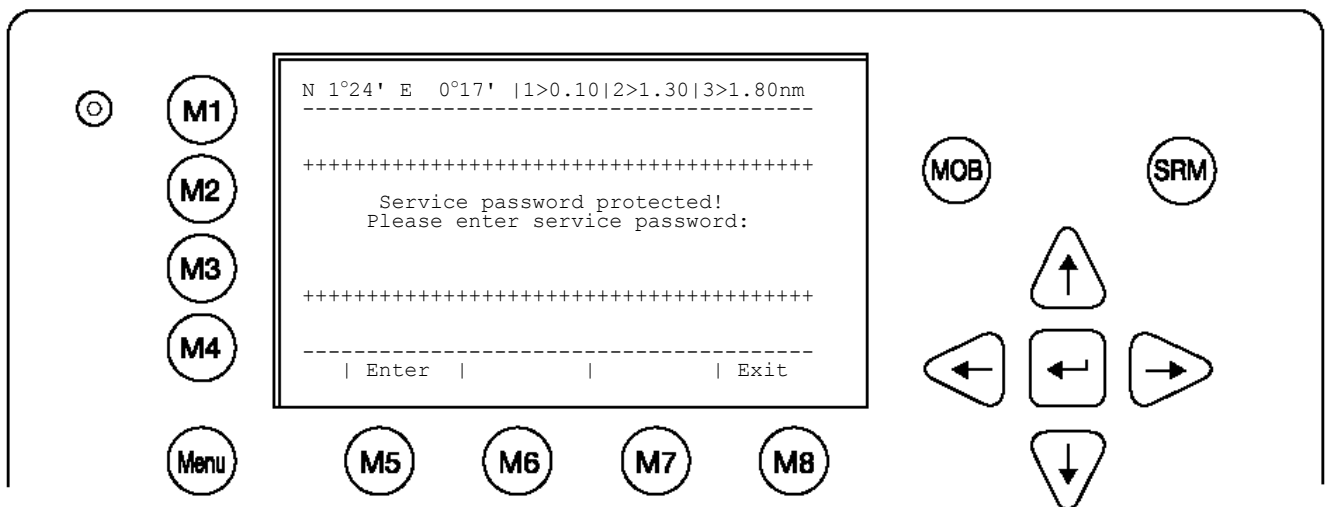

Select Submenu 1 “Change Service Password” with cursor button [Up] & [Down] by pressing Number 1 on the keyboard.

Service Menu Example:

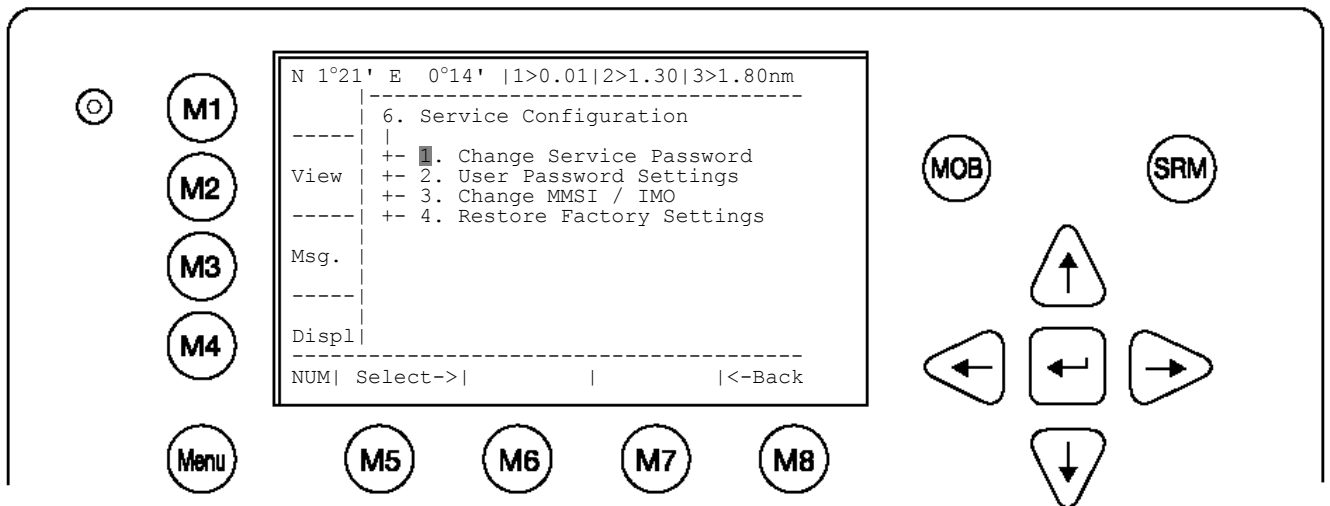

Service Password Menu Example:

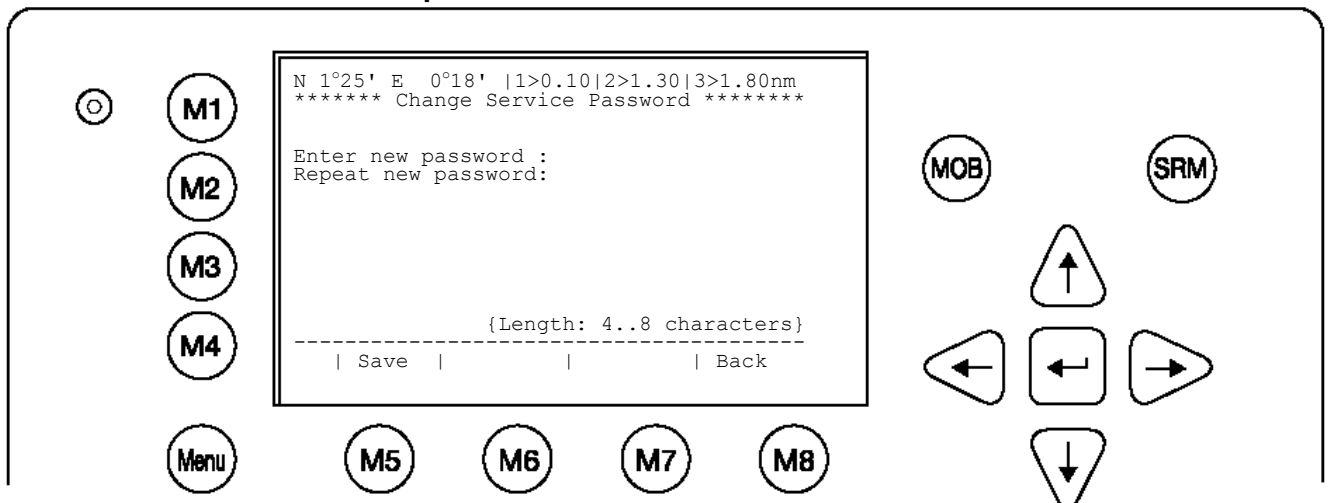

Enter the new Password: Then push Enter (M5).
Repeat the new Password: Then Push Enter (M5).

A minimum of 6, a maximum of 8 characters are allowed. Should the new password include numbers, use the shift key to generate them.

Press Save to store the change.

Changing the User Password

Select Submenu 2 “User Password Settings” with cursor button [Up] & [Down] by pressing number 2 on the keyboard.

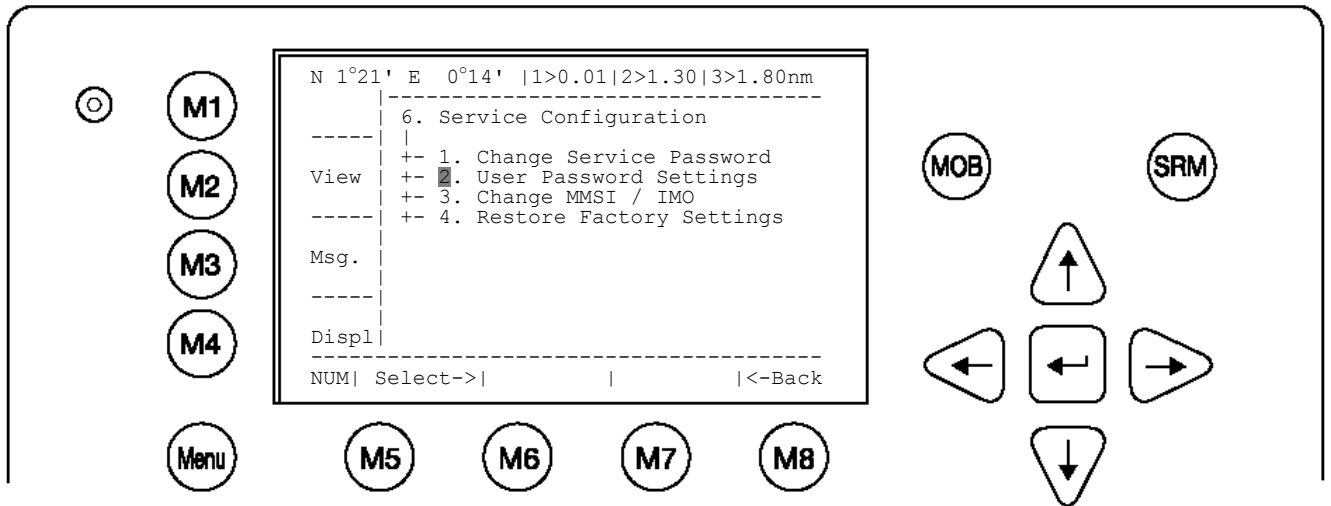

Select Submenu 1 “Change User Password” with cursor button [Up] & [Down] by pressing Number 1 on the keyboard.

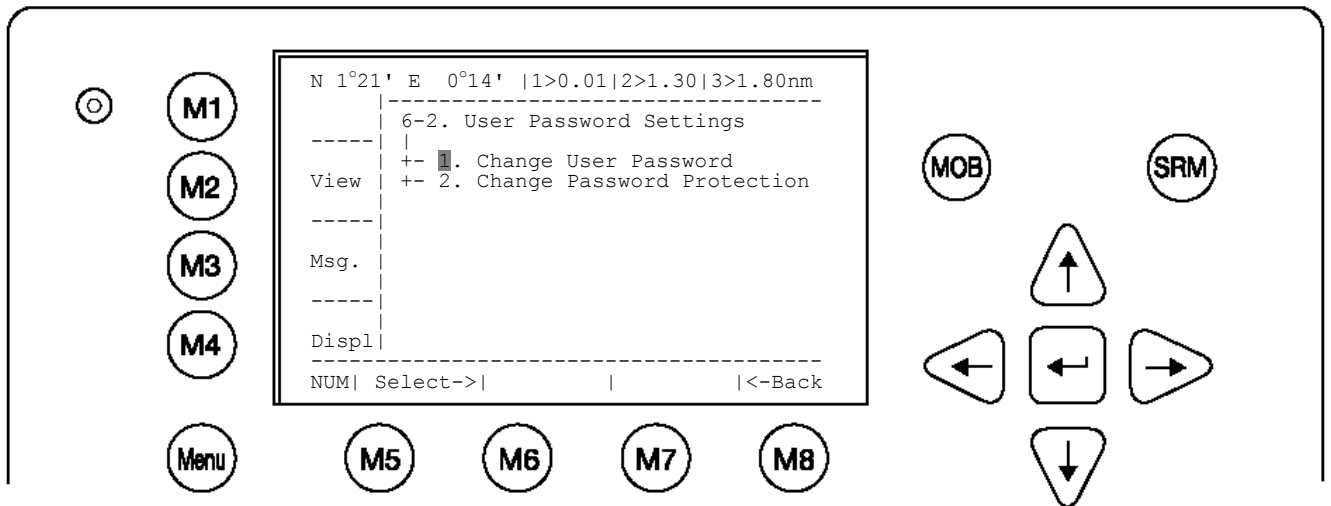

Enter the new Password:

Repeat the new Password:

A minimum of 6, a maximum of 8 characters are allowed. Should the new password include numbers, use the shift key to generate them.

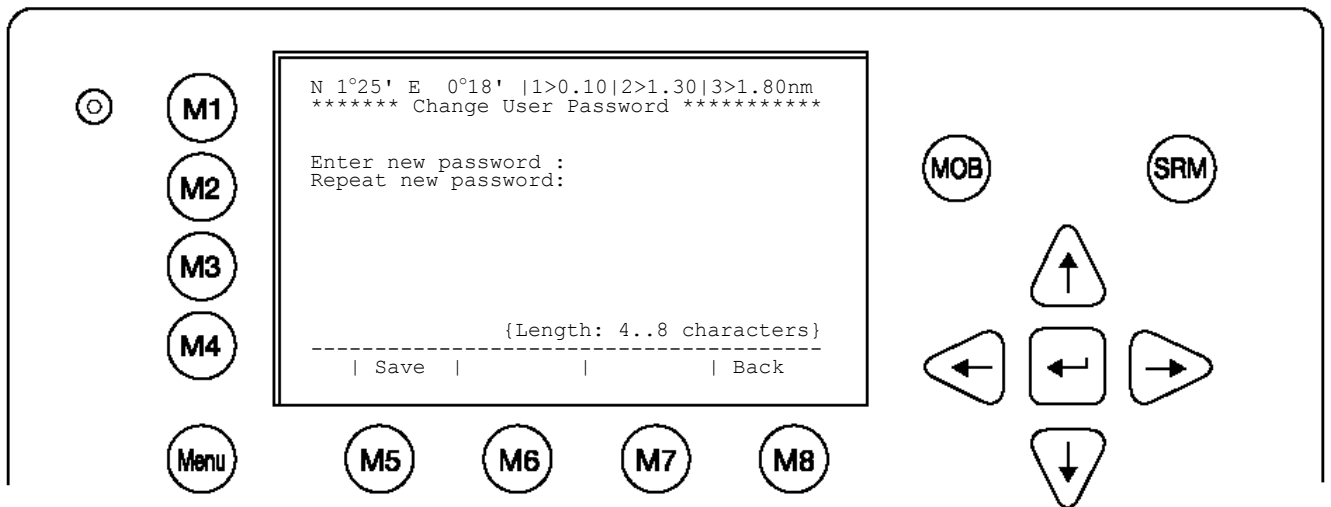

Press Save to store the changes.

5 Troubleshooting

5.1 Reading and understanding Alarms:

The NAUTICAST differentiates between Alarm and TXT messages. An Alarm informs the user about major system malfunctions and failings in the connected sensors. The Alarm Status informs the user about all active Alarms. The Alarm will be disabled and deleted from the Alarm Status, as soon as the displayed problem has been rectified.

The TXT status displays additional sensor information and the UTC clock status. See tables (Section 5.2 and 5.3) for Alarm and TXT Messages.

Select "AIS Status" with cursor button [Up] & [Down] or press Number 2 on the keyboard.

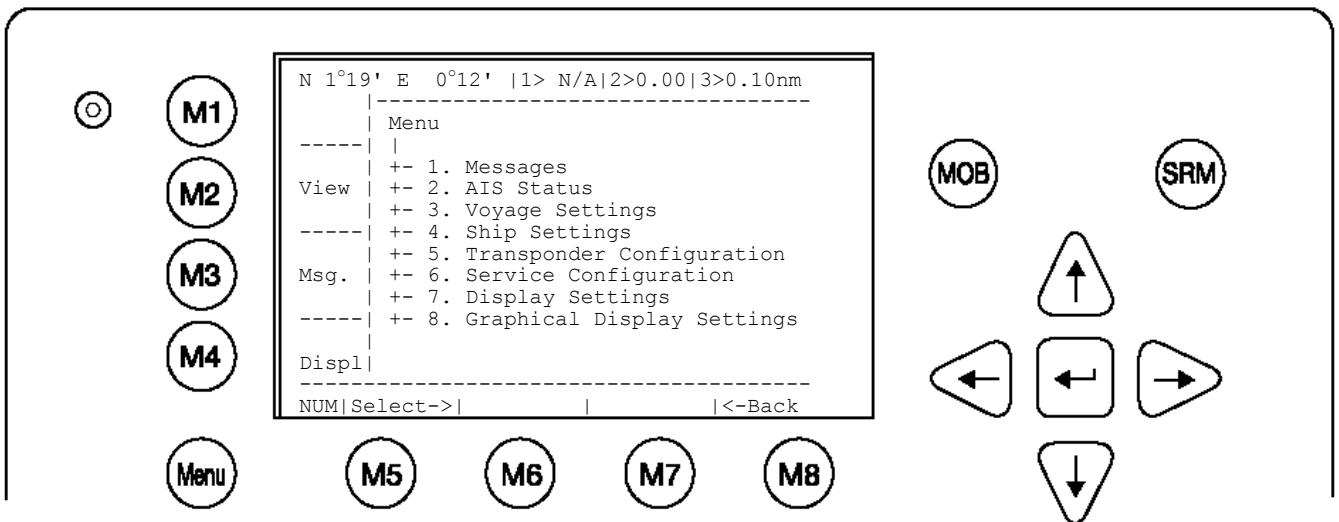

Select "Alarm Status" or "TXT Status" with cursor button [Up] & [Down] or press Number 4 or 5 on the keyboard.

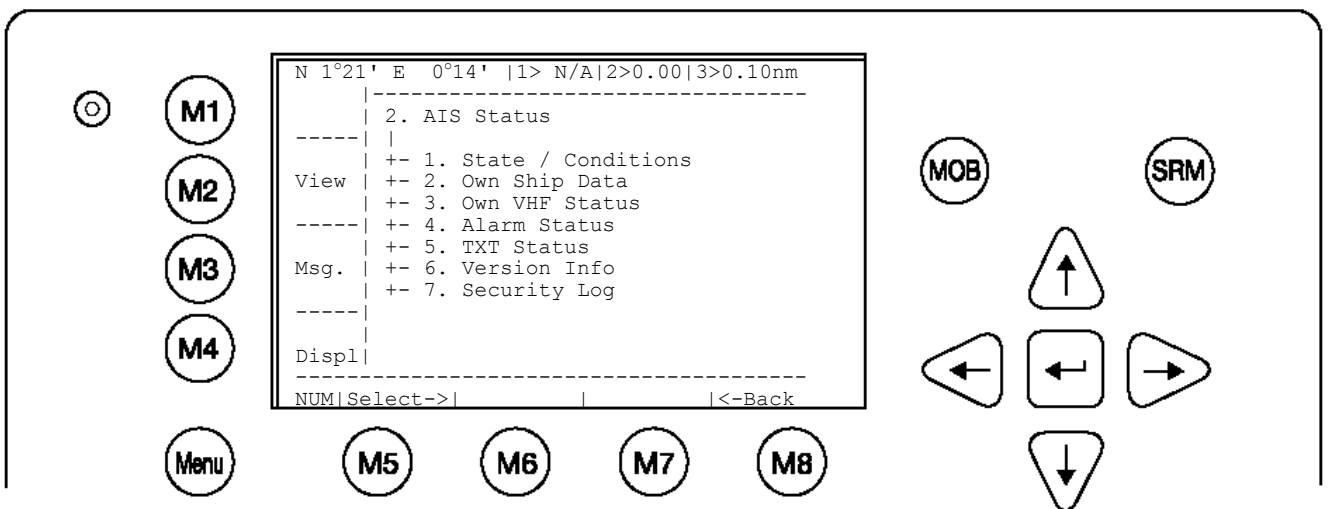

5.2 Alarm Codes

ID	Description Text	Cause/Source	System Reaction / Remedy
01	AIS: Tx malfunction	VHF Antenna, cabling	Reaction: The transponder unit stops transmission. If Alarm ID 01 and ID 02 are simultaneously displayed, then a major antenna problem has arisen. Remedy: Check if the antenna is AIS compatible (156-162 MHz) and if the antenna cabling has a short circuit or is missing any contacts at the connectors. If the ID 01 is displayed as a stand alone message, then the unit requires replacing.
02	AIS: Antenna VSWR exceeds limit (VSWR - Voltage Standing Wave Ratio)	VHF antenna, installation	Reaction: The transponder unit continues transmission. Remedy: Check the antenna and the antenna cabling (RG214 / 50 Ohm cable required).
03	AIS: Rx channel 1 malfunction	Internal error	Reaction: The transponder unit stops transmission on the affected channel, Remedy; If this alarm reoccurs regularly, then the transponder unit requires replacing.
04	AIS; Rx channel 2 malfunction		
05	AIS: Rx channel 70 malfunction		
06	AIS: General failure	Internal error	Reaction: The transponder unit stops transmission. Remedy; The transponder unit requires replacing.
25	AIS; External EPFS lost (EPFS = electronic Position Fixing System such as GPS)	No valid data on Ch1, Ch2 or Ch3 is available	Reaction: The transponder unit continues operation using the position data of the internal GPS. If there is no valid position data available from the internal GPS, error 026 is additionally displayed. Remedy: Id 25 indicates that the sentences GLL, GNS, GGA, RMC cannot be received. Check the sensor and the cabling; check if the system that delivers the data is working. Check the baud rate settings of the sensor inputs. AIS requires the protocol NMEA 0183 V3.0!
26	AIS: No sensor position in use	No valid position from internal GPS or external position sensor	Reaction: The transponder unit continues operation. Remedy: Check the sensor cabling and the antenna of the internal GPS sensor.
29	AIS: No valid SOG information	No valid data from external speed sensor or internal GPS	Reaction: The transponder unit continues operation and displays SOG: N/A Remedy: The sentences VBW, VTG, RMC cannot be received. Check the sensor and the cabling; check if the system that delivers the data is working. Check the baud rate settings of the sensor inputs. AIS requires the protocol NMEA 0183 V3.0!
30	AIS: No valid COG Information	No valid data from external sensor or internal GPS	Reaction: The transponder unit continues operation and displays COG: N/A Remedy: The sentences VBW, VTG, RMC cannot be received. Check the sensor and the cabling, check if the system that delivers the data is working. Check the baud rate settings of the sensor inputs. AIS requires the protocol NMEA 0183 V3.0!
32	AIS: Heading lost/invalid	No valid data from external sensor (Gyrocompass)	Reaction: The transponder unit continues operation Remedy: The sentence for HDT cannot be received. Check the sensor and the cabling, check if the system that delivers the data is working. Check the baud rate settings of the sensor inputs. Mention AIS accepts true heading only (no magnetic).
35	AIS: No valid ROT Information	No ROT indicator is used. No valid data from external sensor	Reaction: The transponder unit continues operation Remedy: The sentence for ROT cannot be received. If a Rate Of Turn indicator is not in use, then it suffices to just acknowledge the alarm. The Alarm Status will store the information that no ROT sensor is available. Otherwise, check the sensor and the cabling. Check if the system that delivers the data is working. Check the baud rate settings of the sensor inputs. The AIS requires the protocol NMEA 0183 V3.0!
53	AIS: BATTERY SOON LOW	Battery is soon out of capacity	Reaction: Own ship data is lost after powering on/off the system. Remedy: consider to contact Technical Support for additional help
55	AIS: PRESS ENTER TO EXIT 1W/AUTO TX MODE	Conditions for enabling 1 Watt TX power are not valid	Reaction: Conditions for enabling 1 Watt TX power are not valid. This means that: <ul style="list-style-type: none"> the speed is >3kn and / or the navigational status is NOT moored / at anchor and / or the ship type is NOT "Tanker" Remedy: <ul style="list-style-type: none"> Check the conditions (SOG, Navstat, Shiptype) if GPS is valid (a invalid GPS causes also this alarm)

56	AIS: ENTER MMSI NUMBER	No valid MMSI entered.	Reaction: During the initial boot or after “factory settings” the user is asked to enter a valid MMSI. As long as this is not done, the system does not transmit. Remedy: Enter a valid MMSI
----	------------------------	------------------------	---

5.3 Text Messages

ID	Description Text	Cause/Source	Reaction of the System / Remedy
07	AIS: UTC clock lost	Internal GPS	Reaction: the transponder unit continues operation using indirect or semaphore synchronisation Remedy: Check GPS Antenna for AIS.
21	AIS: external DGNSS in use	Information	Reaction: Positioning is fully operational Remedy: no action required
22	AIS: external GNSS in use	Information	Reaction: The transponder unit continues operation using the position data from a GNSS receiver Remedy: no action required
23	AIS: internal DGNSS in use (beacon) 023	Information	Reaction: The transponder unit uses position data from the internal source. The internal GNSS receiver is capable of processing DGNSS corrections. Remedy: no action required
24	AIS: internal DGNSS in use (message 17)		
25	AIS: internal GNSS in use	Information additional to Alarm ID 25	Reaction: The transponder unit continues operation using the position data from the internal GPS. Remedy Check the sensor and the cabling; Check if the system that delivers the data is working; Check the baud rate settings of the sensor input
27	AIS: external SOG/COG in use	Information	Reaction: COG/SOG is in full operation Remedy: no action required
28	AIS: internal SOG/COG in use	Information additional to Alarm ID 29 or ID 30	Reaction: The transponder unit continues operation using the data from the internal GPS. Remedy: Check the sensor and the cabling; Check if the system that delivers the data is working; Check the baud rate settings of the sensor inputs
31	AIS: Heading valid	Information	Reaction: Heading is in full operation Remedy: no action required
33	AIS: Rate of Turn Indicator in use	Information	Reaction: A Rate Of Turn indicator is connected and in full operation Remedy: no action required
34	AIS: Other ROT source in use	Information	Reaction: The transponder unit is operating with ROT data rather than with TIROT data - therefore the AIS only differs between + 127 (turning right at 720 degrees per minute or higher) and - 127 (turning left at 720 degrees per minute or higher)

5.4 Restarting the NAUTICAST

The NAUTICAST can be restarted during operation by pressing the keys “Shift” + “Fn” + “Del” simultaneously. It may take up to 6 minutes to receive all information from other ships again because of their reporting interval.

6 Accessories

The following material is included with the NAUTICAST.

- 1 NAUTICAST Inland AIS Transponder
- 1 installation manual, 1 user Manual
- 3 caps of plug
- 1 cable clamp (M5 thread)
- 1 guide plate Kit
- 3 angles + 3 mounting screws (screw bolt + square nut)

The NAUTICAST Inland AIS is supplied with some of the components listed below (contents depend on customer requirements).

PRODUCT NUMBER	PRODUCT DESCRIPTION
AIS Cable	
2610	AIS Interface Cable (Power & Data) between Transponder and Connection Box & Pilot Plug, 3 meters (9.8ft) Halogen Free, IP67
2611	AIS Interface Cable (Power & Data) between Transponder and Connection Box & Pilot Plug, 10 meters (32.8ft) Halogen Free. IP67
2614	AIS Interface Cable (Power & Data) between Transponder and ECS, 1.5 meters (4.9ft)
2617	AIS Interface Cable (Power & Data) between Transponder and PC 1.5 meters (2 sensor only)
GPS/VHF Cable	
2612	GPS/VHF Interface Cable, 1meter (3.3ft) Includes 1 each Female N and TNC connectors installed and 1 each Male N and TNC connectors for RG214 cable (specify length) Not Required with P/N 2624 VHF/GPS Combi Antenna.
2613	GPS/VHF Interface Cable, 10 meters(32.8ft) Includes 1 each Male PL & TNC connector installed. (Not Required with P/N 2624 VHF/GPS Combi Antenna.)
ACR VHF Antenna Solution	
2628	VH-3200 VHF Stainless Steel Whip Antenna 91.4cm (36in) Includes Mounting Kit & Plug PL Male for RG214
2621	Comrod AV 7 VHF Fiberglass Antenna 1.22m(4ft) Includes Aluminum mount (Vert or Horiz.. stanchion, or bulkhead) When used with P/N 2612, 1 P/N 2632 PL Male Connector & P/N 2630 cable (specify length) are required.
ACR GPS Antenna Solution	
2622	ProCom GPS4 Quadrifilar Helix Antenna 5 Volt. When used with P/N 2612 interface, one P/N 2633 TNC Connector & P/N 2630 cable (Specify length) are required. Mount P/N 2623 is required.
2623	ProCom FLG Deck Mounting Kit Metal Horiz.. surface (for P/N 2622)
ACR VHF/GPS Combination Antenna Solution (in lieu of individual VHF and GPS antenna solutions)	
2624	Comrod AC17 Combi Antenna (combined GPS/VHF) includes Aluminum mount (Vert or Horiz.. Stanchion or bulkhead) & 1m interface cable. If longer cable required, order P/N 2630 cable (specify length) and 2 P/N 2631 Male N connectors. P/N 2612 or 2613 are not required with this option.
Optional VHF/GPS Antenna Cable extensions and Plugs (select or supply own cable)	
2630	GPS/VHF RF Antenna Cable extension cable RG214 (No Plugs) Sold per meter
2631	N Male RG214 Crimp
2632	PL Male RG214 Crimp
2633	TNC Male RG214 Crimp
Optional AIS Cable Connection Box (Required for Advanced Installation with ECDIS, etc.)	
2640	Connection Box
Optional 12vt to 24vt DC to DC Converter (Required for 12vt power systems)	
2642	12v to 24v DC to DC Power Converter.
Optional Mounting Bracket Assemblies for UAIS Nauticast™	
2650	Mounting Bracket Gimbal Style (Includes 4 screws and 2 Mounting Knobs)
2651	Retro Fit Frame Drop In Mount (Includes 3 screws, nuts, clips to hold display to bracket)
2652	Frame for Rack Mount. 48.3cm (19in) Includes 3 Bolts and Nuts to hold display to bracket. Discontinued

7.1 ERI Ship Types

code	U	ship name	Msg 5 (1-99)		Ship Type - SOLAS	
			dig1	dig2	Type (first digit)	Cargo (Second digit)
8000	No	Vessel, type unknown	9	9	Other types of Ship	No additional information
8010	V	Motor freighter	7	9	Cargo Ships	No additional information
8020	V	Motor tanker	8	9	Tanker	No additional information
8021	V	Motor tanker, liquid cargo, type N	8	0	Tanker	All ships of this type
8022	V	Motor tanker, liquid cargo, type C	8	0	Tanker	All ships of this type
8023	V	Motor tanker, dry cargo as if liquid (e.g. cement)	8	9	Tanker	No additional information
8030	V	Container vessel	7	9	Cargo Ships	No additional information
8040	V	Gas tanker	8	0	Tanker	All ships of this type
8050	C	Motor freighter, tug	7	9		No additional information
8060	C	Motor tanker, tug	8	9	Tanker	No additional information
8070	C	Motor freighter with one or more ships alongside	7	9	Cargo Ships	No additional information
8080	C	Motor freighter with tanker	8	9	Tanker	No additional information
8090	C	Motor freighter pushing one or more freighters	7	9	Cargo Ships	No additional information
8100	C	Motor freighter pushing at least one tank-ship	8	9	Tanker	No additional information
8110	No	Tug, freighter	7	9	Cargo Ships	No additional information
8120	No	Tug, tanker	8	9	Tanker	No additional information
8130	C	Tug freighter, coupled	3	1	Vessel	Towing
8140	C	Tug, freighter/tanker, coupled	3	1	Vessel	Towing
8150	V	Freightbarge	9	9	Other types of Ship	No additional information
8160	V	Tankbarge	9	9	Other types of Ship	No additional information
8161	V	Tankbarge, liquid cargo, type N	9	0	Other types of Ship	All ships of this type
8162	V	Tankbarge, liquid cargo, type C	9	0	Other types of Ship	All ships of this type
8163	V	Tankbarge, dry cargo as if liquid (e.g. cement)	9	9	Other types of Ship	No additional information
8170	V	Freightbarge with containers	8	9	Tanker	No additional information
8180	V	Tankbarge, gas	9	0	Other types of Ship	All ships of this type
8210	C	Pushtow, one cargo barge	7	9	Cargo Ships	No additional information
8220	C	Pushtow, two cargo barges	7	9	Cargo Ships	No additional information
8230	C	Pushtow, three cargo barges	7	9	Cargo Ships	No additional information
8240	C	Pushtow, four cargo barges	7	9	Cargo Ships	No additional information
8250	C	Pushtow, five cargo barges	7	9	Cargo Ships	No additional information
8260	C	Pushtow, six cargo barges	7	9	Cargo Ships	No additional information
8270	C	Pushtow, seven cargo barges	7	9	Cargo Ships	No additional information
8280	C	Pushtow, eighth cargo barges	7	9	Cargo Ships	No additional information
8290	C	Pushtow, nine or more barges	7	9	Cargo Ships	No additional information
8310	C	Pushtow, one tank/gas barge	8	0	Tanker	All ships of this type
8320	C	Pushtow, two barges at least one tanker or gas barge	8	0	Tanker	All ships of this type
8330	C	Pushtow, three barges at least one tanker or gas barge	8	0	Tanker	All ships of this type
8340	C	Pushtow, four barges at least one tanker or gas barge	8	0	Tanker	All ships of this type
8350	C	Pushtow, five barges at least one tanker or gas barge	8	0	Tanker	All ships of this type
8360	C	Pushtow, six barges at least one tanker or gas barge	8	0	Tanker	All ships of this type
8370	C	Pushtow, seven barges at least one tanker or gas barge	8	0	Tanker	All ships of this type

8380	C	Pushtow, eight barges at least one tanker or gas barge	8	0	Tanker	All ships of this type
8390	C	Pushtow, nine or more barges at least one tanker or gas barge	8	0	Tanker	All ships of this type
8400	V	Tug, single	5	2	Tugs	-
8410	No	Tug, one or more tows	3	1	Vessel	Towing
8420	C	Tug, assisting a vessel or linked combination	3	1	Vessel	Towing
8430	V	Pushboat, single	9	9	Other types of Ship	No additional information
8440	V	Passenger ship, ferry, cruise ship, red cross ship	6	9	Passenger Sips	No additional information
8441	V	Ferry	6	9	Passenger Sips	No additional information
8442	V	Red cross ship	5	8	Medical transports	-
8443	V	Cruise ship	6	9	Passenger Sips	No additional information
8444	V	Passenger ship without accomodation	6	9	Passenger Sips	No additional information
8450	V	Service vessel, police patrol, port service	9	9	Other types of Ship	No additional information
8460	V	Vessel, work maintenance craft, floating derrick, cable-ship, buoy-ship, dredge	3	3	Vessel	Engaged in dredging or underwater operations
8470	C	Object, towed, not otherwise specified	9	9	Other types of Ship	No additional information
8480	V	Fishing boat	3	0	Vessel	All ships of this type
8490	V	Bunkership	9	9	Other types of Ship	No additional information
8500	V	Barge, tanker, chemical	8	0	Tanker	All ships of this type
8510	C	Object, not otherwise specified	9	9	Other types of Ship	No additional information
1500	V	General cargo Vessel maritime	7	9	Cargo Ships	No additional information
1510	V	Unit carrier maritime	7	9	Cargo Ships	No additional information
1520	V	bulk carrier maritime	7	9	Cargo Ships	No additional information
1530	V	tanker	8	0	Tanker	All ships of this type
1540	V	liquified gas tanker	8	0	Tanker	All ships of this type
1850	V	pleasure craft, longer than 20 metres	3	7	Vessel	Pleasure Craft
1900	V	fast ship	4	9	HSC – high speed craft	No additional information
1910	V	hydrofoil	4	9	HSC – high speed craft	No additional information
1920	V	catamaran fast	4	9	HSC – high speed craft	No additional information

8 Contact and Support Information

Contact your local dealer for NAUTICAST support.
Please see our ACR Website for Service Listing.

ACR Electronics Europe GmbH
Handelskai 388 / Top 632
A-1020 Vienna, Austria
Tel: +43 (1) 5 237 237 – 0
Fax: +43 (1) 5 237 237 – 150
Email: Technical.Support@acr-europe.com
Web: www.acr-europe.com

ACR Electronics
Customer Service
5757 Ravenswood Road
Fort Lauderdale, FL 33312, USA
Tel.: +1 (954) 981-3333
Fax: +1 (954) 983-5087
Email: info@acrelectronics.com
Web: www.acrelectronics.com

9 Appendix

9.1 Samples for battery calculation

9.1.1 Typical Installation

GMDSS Battery size calculation for 1 hour (Battery size calculation based on the IMO regulations Chapter IV - Reg.13)

Ship Name QMIII
 Battery capacity 230Ah
 Battery Type 2x (12V / 135)
 Area A1, A2, A3

Battery located in battery chest on observation deck

Pos	Qty.	Equipment	I _{max} (A)	I _{standby} (A)	Total (A) (I _{max} /2 + I _{standby})*Qty.)
1	1	Skanti TRP 8751D Radiotelephone	45,00	3,00	25,50
2	1	Debeg 3818 DSC Controller		0,21	0,21
3	2	T&T 3020 Inmarsat-C Transceiver	3,20	0,40	4,00
4	2	Inmarsat-C Monitor		0,85	1,70
5	2	Inmarsat-C Printer	1,00	0,20	1,40
6	1	CI 8501 Navtex Receiver		0,50	0,50
7	2	Skanti USE 300 VHF Radiotel.	2,80	0,05	2,90
8	2	Debeg 3817 VHF DSC Controller		0,21	0,42
9	1	Sailor RT2047 VHF Radio Tel.	6,50	1,00	4,25
10	1	Simrad GN 33 GPS		0,63	0,63
11	1	Koden KGP 900 GPS	4,00	0,63	2,63
12	1	Koden LR 771 Loran C		0,42	
13	1	Emergency light		2,00	2,00
14	1	AIS Nauticast	7,00	0,75	0,84
				Total	46,98

$K1_{\text{partly discharged battery}} = \text{Total consumption} \times 1,25 = 58,73 \text{ Ah}$

$K1_{-30^\circ} = K1 \times 1 / 0,30 = 106,78 \text{ Ah}$

$K5 = K1_{-30^\circ} / 0,65 = 164,28 \text{ Ah}$

Selected Battery (K5) = 230,00 Ah

$K1_{\text{partly discharged battery}} =$

correction factor taking care that the battery might not be fully charged
 (we assume that in worst case the battery is only at 80% fully charged)

$K1_{-30^\circ} =$

correction factor taking care that the battery may be used
 at ambient temperature of - 30 degrees

(at -30 degrees the battery has only 30% of nominal capacity)

$K5 =$ correction factor taking care of that the battery

is defined by manufacturer for 5 hours discharge time

Calculation for AIS =

transmit pulse length 26,6ms with a maximum repetition rate of 2 seconds results in a maximum of 30 pulses/minute → 1800 pulses/hour x 26,6 ms → 47880 ms → 47,88 seconds transmit time during one hour 47,88 seconds → 0,8 minutes → 0,0133 hours transmitting time during one hour operation
 → Up-Rounded to 0,02 hrs transmitting time

Above mentioned calculation assumes that all equipment is in operation which is normally not valid, that means that the actual consumption is lower.

9.1.2 RM GMDSS Compact-Console Area A3 with 250 W MF/HF

GMDSS Reserve Battery Calculation (24 V DC) for Raytheon Marine GmbH GMDSS Compact-Console Area A3 with 250 W MF/HF

According to IMO Regulation COMSAR/Circ.16 4. March 1998

A: with Emergency Generator (SOLAS IV 13.2)

The GMDSS equipment shall be able to operate one (1) hour on reserve power with 50% of time in transmission mode and 50% in receiving mode.

B: without Emergency Generator (SOLAS IV 13.2)

The GMDSS equipment shall be able to operate six (6) hours on reserve power with 50% of time in transmission mode and 50 % of receiving mode.

Equipment	Type	Transmitting	Receiving	Additional
MF/HF	STR 2000 R	15 A	4 A incl.DSC	
Inmarsat C	STR 1500 CN	5 A	1,8 A incl.EGC	
VHF 1 with DSC	VHF1000DSC	6,5 A	0,65 A incl.DSC	
VHF 2 with DSC	VHF1000DSC	6,5 A	0,65 A incl.DSC	
AIS	RM 808 AIS	5,0 A	1,0 A	
Emergency Light				2,5 A
Total		38 A	8,1 A	2.5 A

Calculation:

Case A:

$1h \times (0.5 I_{TX} + I_{RX} + I_{Add}) \times 1.4 = 41.44 \text{ Ah}$

recommend battery capacity is 86 Ah

Charger:

$I_{Charg} \times 0.1 I_{Batt/h} = 8.6 \text{ A}$

recommend charger is type 20 A

Case B:

$6h \times (0.5 I_{TX} + I_{RX} + I_{Add}) \times 1.4 = 248.66 \text{ Ah}$

The battery calculation should not be used for uninterruptible power supply (UPS) configuration.

9.1.3 RM GMDSS Compact-Console Area A3 with 400 W MF/HF

GMDSS Reserve Battery Calculation (24 V DC) for Raytheon Marine GmbH GMDSS Compact-Console Area A3 with 400 W MF/HF

According to IMO Regulation COMSAR/Circ.16 4. March 1998

A: with Emergency Generator (SOLAS IV 13.2)

The GMDSS equipment shall be able to operate one (1) hour on reserve power With 50% of time in transmission mode and 50% in receiving mode.

B: without Emergency Generator (SOLAS IV 13.2)

The GMDSS equipment shall be able to operate six (6) hours on reserve power with 50% of time in transmission mode and 50 % of receiving mode.

Equipment	Type	Transmitting	Receiving	Additional
MF/HF	STR 2000	18.75 A	4 A incl.DSC	
Inmarsat C	STR 1500 CN	5 A	1,8 A incl.EGC	
VHF 1 with DSC	VHF1000DSC	6.5 A	0,65 A incl.DSC	
VHF 2 with DSC	VHF1000DSC	6.5 A	0,65 A incl.DSC	
AIS	RM 808 AIS	5.0 A	1,0A	
Emergency Light				2,5 A
Total		41.75 A	8,1 A	2.5 A

Calculation:

Case A:

$$1\text{h} \times (0.5 I_{TX} + I_{RX} + I_{Add}) \times 1.4 = 44.06 \text{ Ah}$$

recommend battery capacity is 86 Ah

Charger:

$$I_{Charg} \times 0.1 I_{Batt/h} = 8.6 \text{ A}$$

recommend charger is type 20 A

Case B:

$$6\text{h} \times (0.5 I_{TX} + I_{RX} + I_{Add}) \times 1.4 = 264.39 \text{ Ah}$$

The battery calculation should not be used for uninterruptible power supply (UPS) configuration

9.2 Drawings and Approvals

These documents are included on the following pages:

- (1) Dimensional Drawings**
- (2) Type Approvals**
- (3) Connection Drawings**
- (4) Antenna Layout**
- (5) Quick Replacement Guide**

1 2 3 4 5 6 7 8

Pultmontage
console mounting

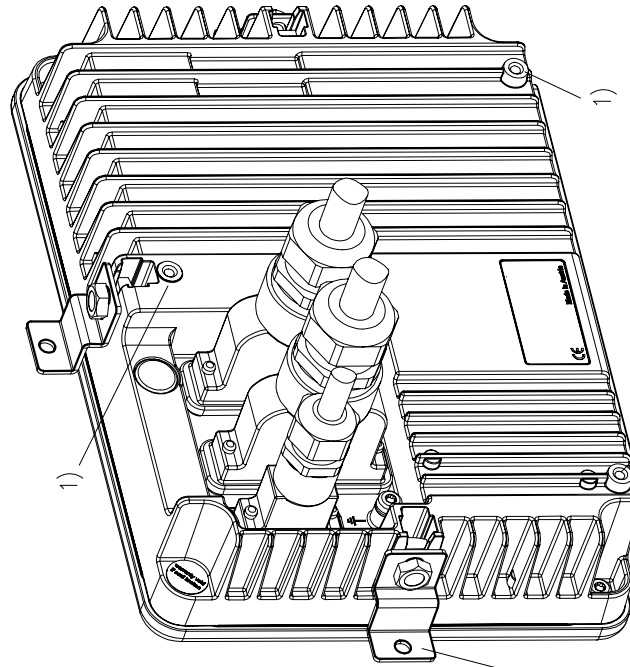
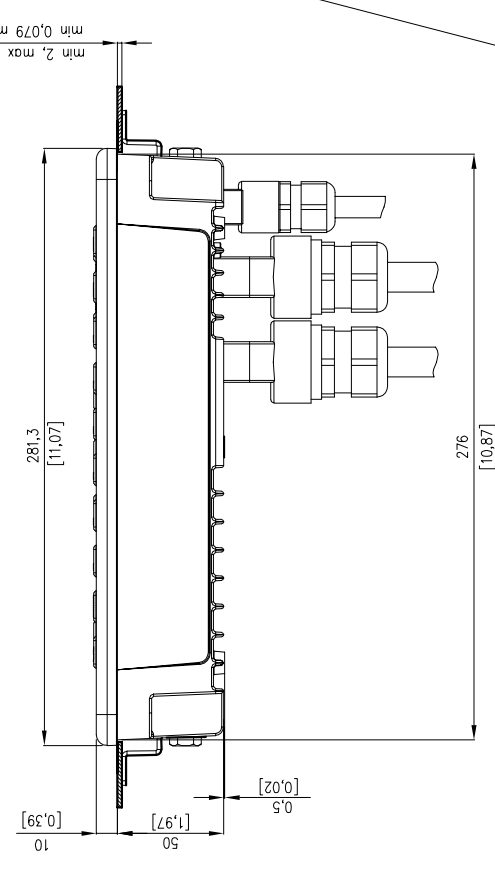

Technische Daten / Specification :

Spannungsversorgung / power supply: 24V DC

Strom / current: 5A

Betriebstemperaturbereich / operation temperature: -15°C to +55°C

Schutzart / type of enclosure: IP65 n. EN60529

magnetischer Schutzabstand / magnetic safety distance: 0,3m

Gewicht / weight: 2400g (ohne Kabel / without cable)

Farbe / color: RAL7021 (dark grey)

Montagewinkel (3x)
mounting brackets (3x)

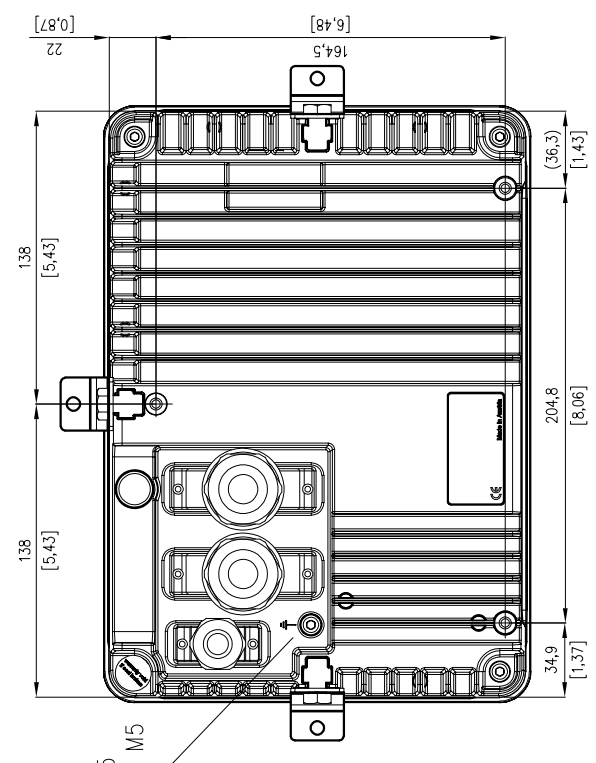
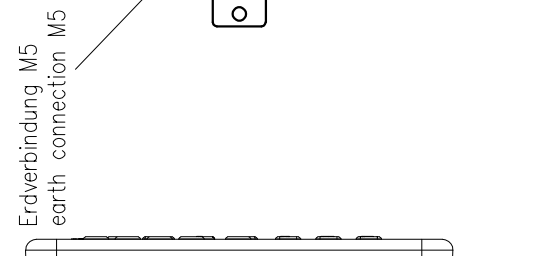
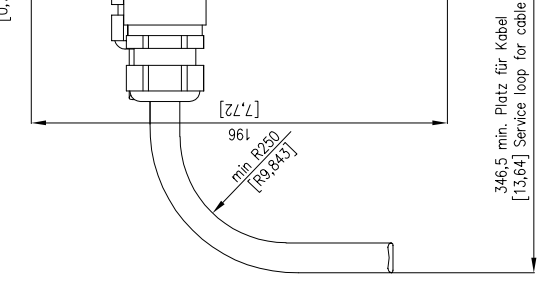
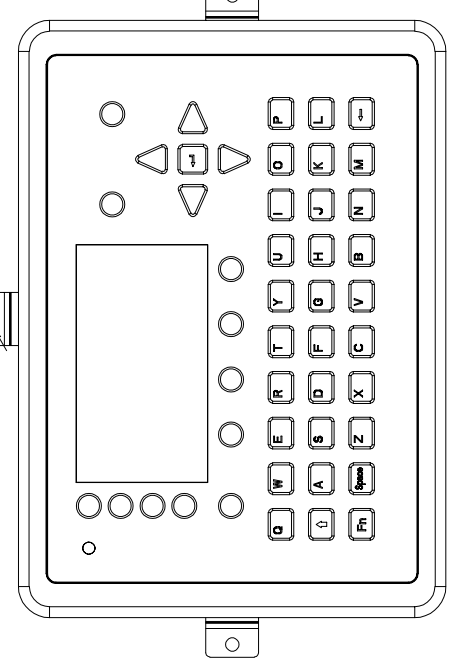
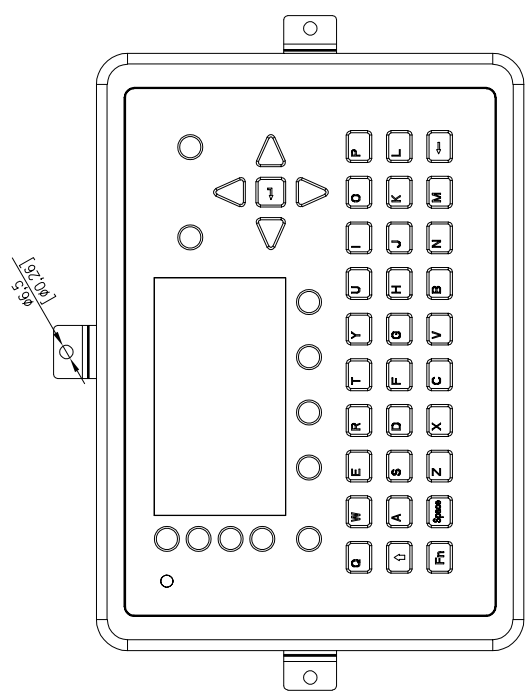

Pultausschnitt
panel cut out

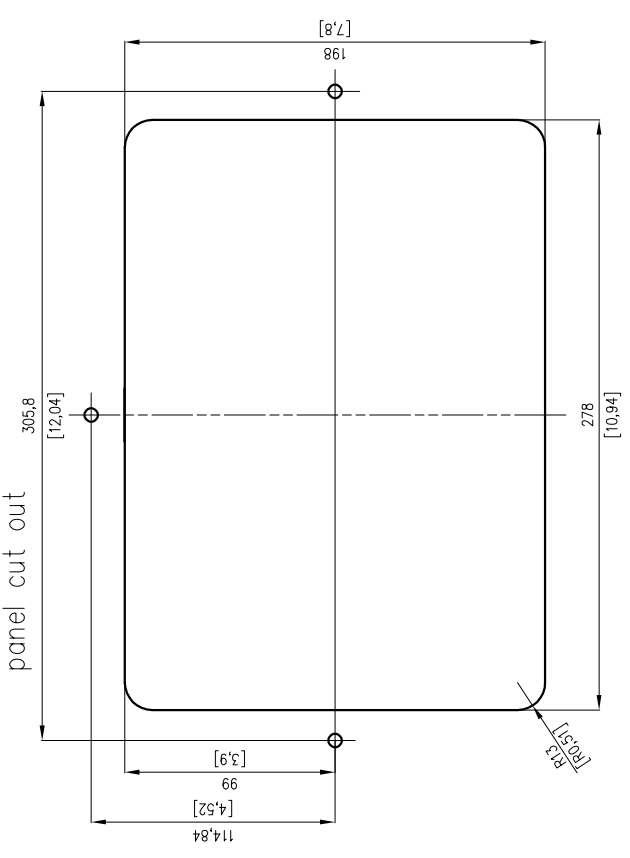

- 1) Befestigungspunkte 3x, Gewindefackloch M5 5tief
fixing points 3x, blind hole thread M5 depth 5

DISTANCE FROM MAGNETIC COMPASS STANDARD TYPE: 0,3m		STEERING TYPE: 0,3m		SCALE		WEIGHT: 2,4 Kg	
mm		[INCH]		CAD		DRAWING TITLE	
DATE		DATE		DRAWING TITLE		DIMENSIONAL DRAWING	
DR 29.04.2003		DP		FOR		Nauticast AIS	
ACCEPTED AL 20.05.2003		DATE		REVISIONS		DATE	
ACR Electronics		20.05.03		1		20.05.03	
5757 Ravenswood Road		DATE		REVISIONS		DATE	
Fort Lauderdale, FL 33312		DATE		REVISIONS		DATE	

Id-Nr.: 2600662

Stromlaufplan
circuit diagram

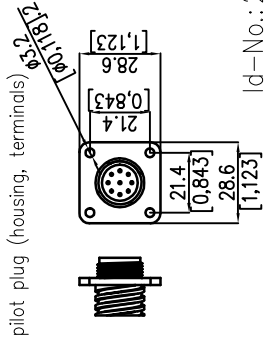
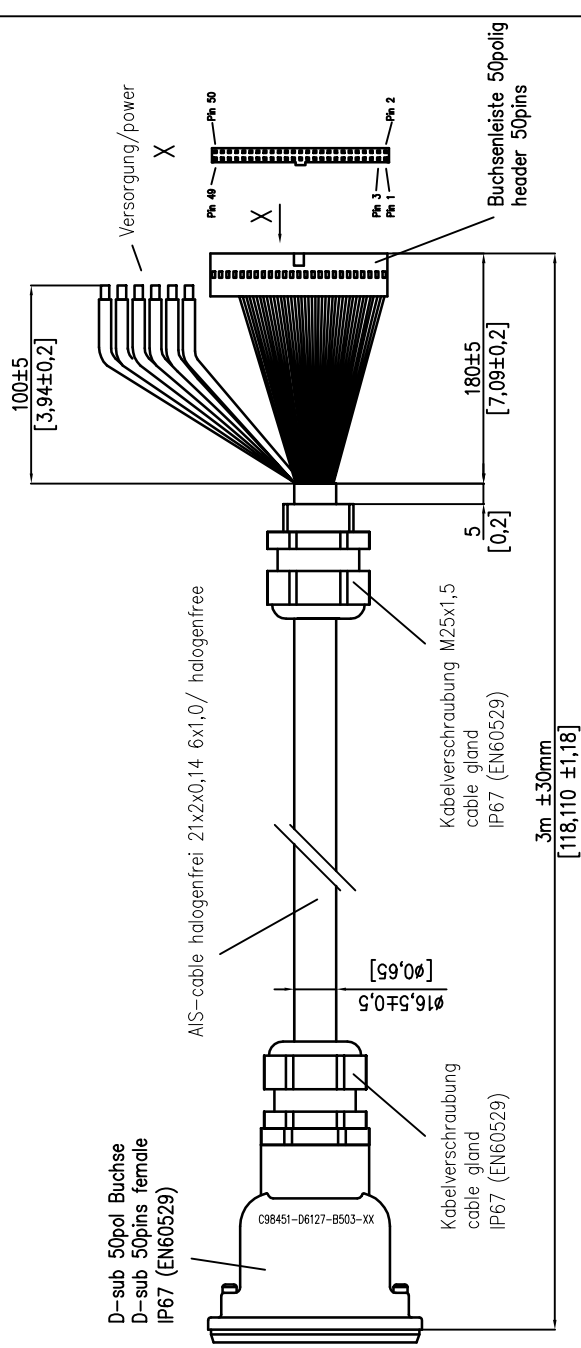
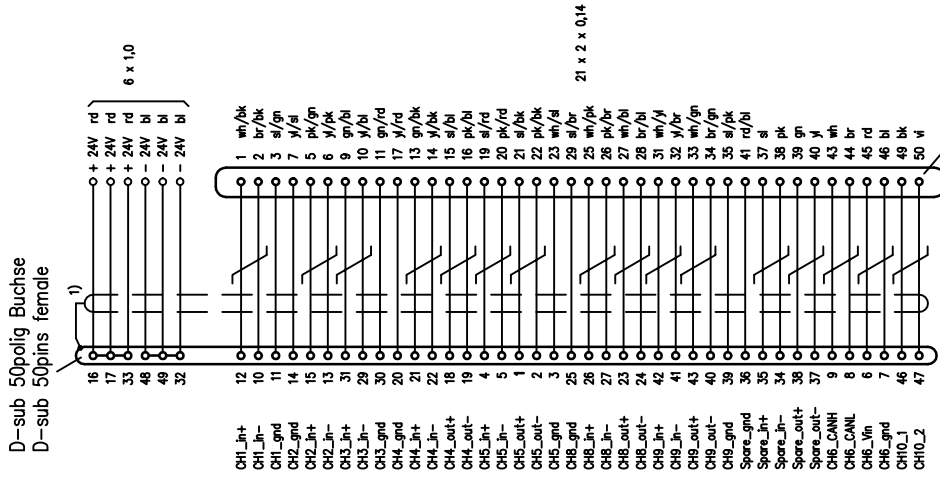

Id-No.: 2600663

DISTANCE FROM MAGNETIC COMPASS		CAD	
STANDARD TYPE:	...m	STEERING TYPE:	...m
SCALE		WEIGHT: 1,4 kg	
DRAWING TITLE			
DIMENSIONAL DRAWING			
FOR AIS cable connection box 3m / [118,110]			
ACCEPTED AL 29.04.2003			
ACR Electronics			
5757 Ravenswood Road			
Fort Lauderdale, FL 33312			
LTR	REVISIONS	DATE	
1		20.05.09	

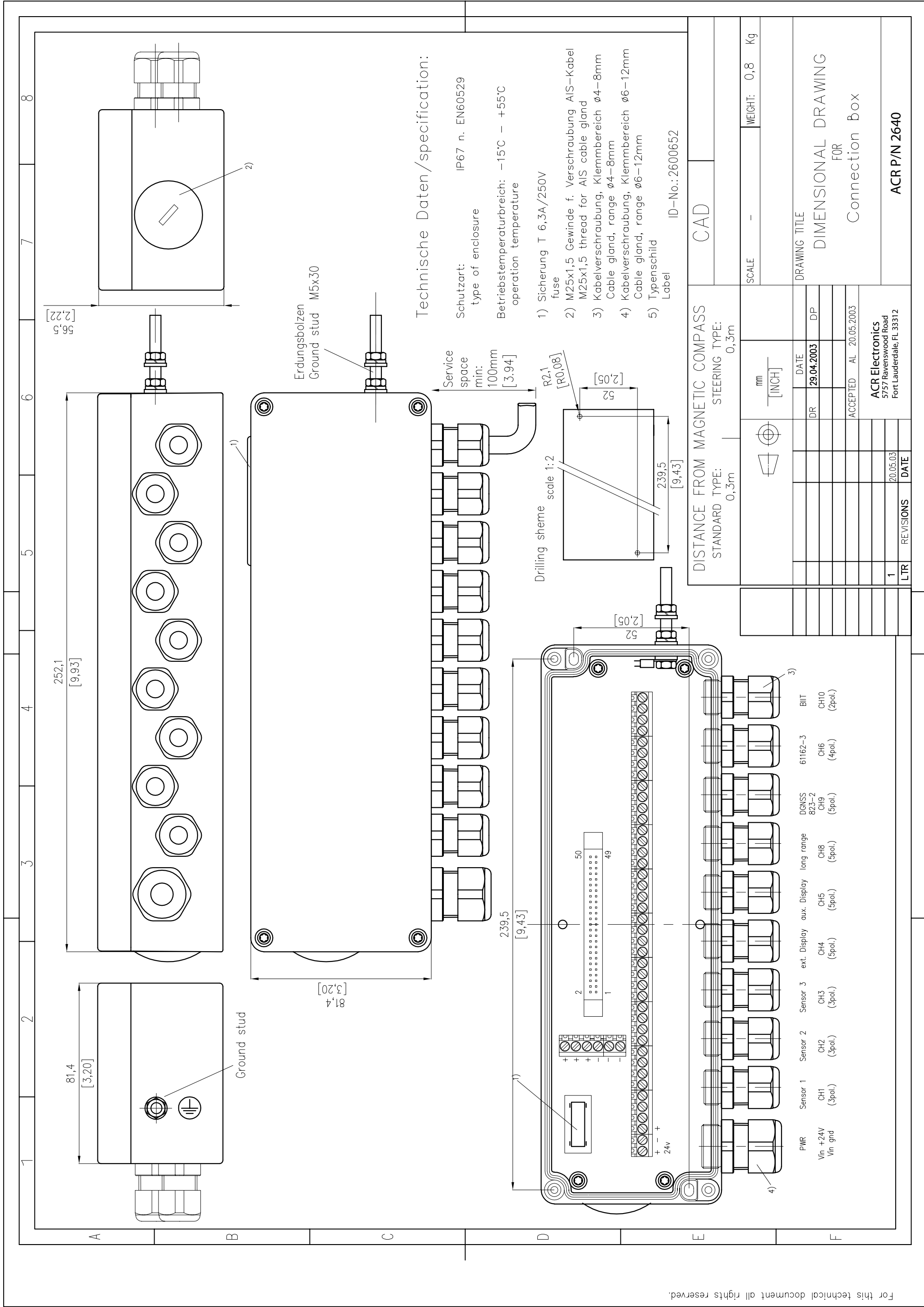

Technische Daten/specification:

- Schutzart: IP67 n. EN60529
type of enclosure
- Betriebstemperaturbereich: -15°C - +55°C
operation temperature
- 1) Sicherung T 6,3A/250V
fuse
- 2) M25x1,5 Gewinde f. Verschraubung AIS-Kabel
M25x1,5 thread for AIS cable gland
- 3) Kabelverschraubung, Klemmbereich ø4-8mm
Cable gland, range ø4-8mm
- 4) Kabelverschraubung, Klemmbereich ø6-12mm
Cable gland, range ø6-12mm
- 5) Typenschild
Label
- ID-No.: 2600652

DISTANCE FROM MAGNETIC COMPASS		CAD	
STANDARD TYPE: 0,3m		SCALE: -	
STEERING TYPE: 0,3m		WEIGHT: 0,8 Kg	
DATE	DR	DATE	DR
29.04.2003	DP	29.04.2003	DP
ACCEPTED	AL	ACCEPTED	AL
20.05.03		20.05.03	
REVISIONS	DATE	REVISIONS	DATE
1		1	
DRAWING TITLE		DRAWING TITLE	
DIMENSIONAL DRAWING		DIMENSIONAL DRAWING	
FOR		FOR	
Connection Box		Connection Box	
ACR P/N 2640		ACR P/N 2640	

PWR	Sensor 1	Sensor 2	Sensor 3	ext. Display	aux. Display	long range	DGNSS	61162-3	BIT
Vin +24V	CH1	CH2	CH3	CH4	CH5	CH8	823-2	CH6	CH10
Vin gnd	(3pol.)	(3pol.)	(3pol.)	(5pol.)	(5pol.)	(5pol.)	CH9	(4pol.)	(2pol.)
							(5pol.)		

THIS DOCUMENT AND THE DATA DISCLOSED HEREIN OR HERETOFORE ARE THE PROPERTY OF ACR ELECTRONICS, INC. (ACR) AND ARE NOT TO BE REPRODUCED, COPIED, OR TRANSMITTED IN ANY FORM OR BY ANY MEANS, WITHOUT THE PERMISSION OF ACR.

1

2

3

4

5

6

7

8

D

C

B

A

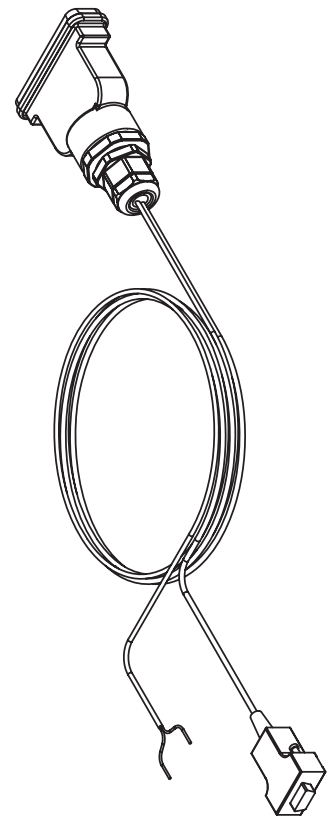
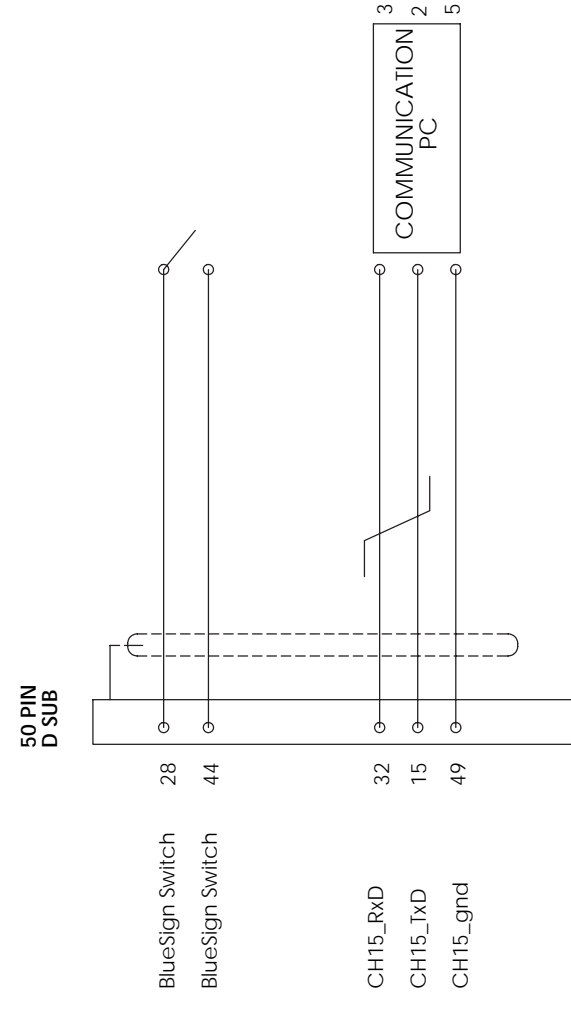
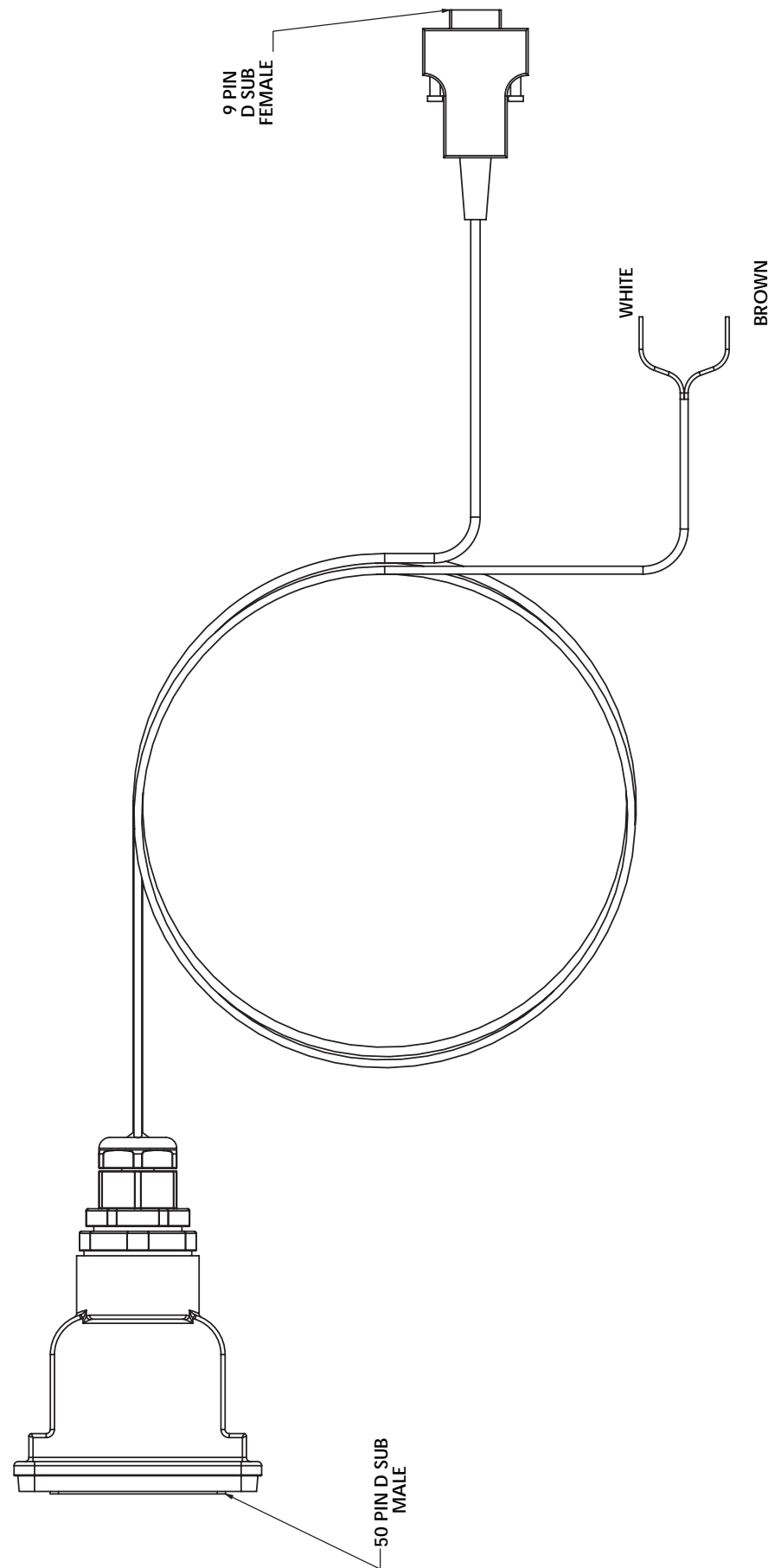

All parts tested to meet requirements of IP 67 and salt spray and corrosion resistance tests.

ACR ELECTRONICS, INC 5157 HAVENWOOD RD. FT. LAUDERDALE FL 33312	
BLUE SIGN CABLE ASSEMBLY	
QTY	2635
DATE	
SCALE	1:1

8

7

6

5

4

3

2

1

THIS DOCUMENT AND THE DATA DISCLOSED HEREIN OR HEREWITH IS PROPERTY OF AND BELONGS TO ACR ELECTRONICS, INC., FT. LAUDERDALE, FL. IT IS FURNISHED IN CONFIDENCE SOLELY FOR INFORMATIONAL PURPOSES. IT IS NOT TO BE REPRODUCED, USED OR DISCLOSED IN WHOLE OR IN PART TO ANYONE WITHOUT THE PERMISSION OF ACR.

4

3

1

B

B

50-pin D sub male connector

9-pin D sub female connector

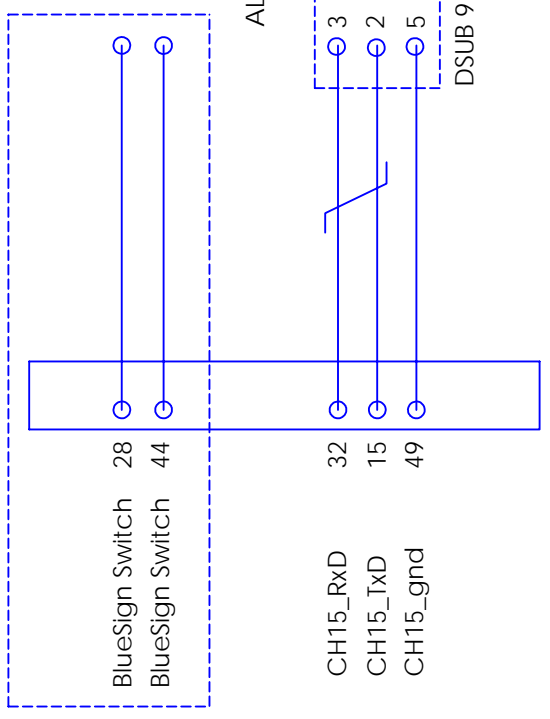
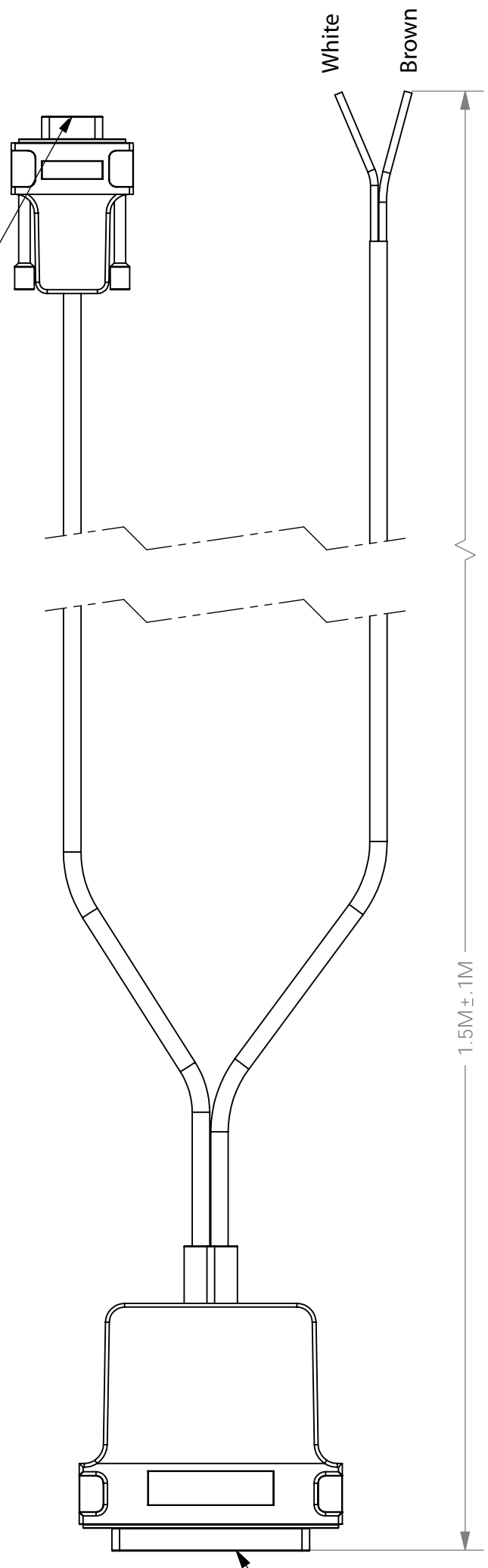

A

A

ACR ELECTRONICS, INC
5757 RAVENSWOOD RD. FT. LAUDERDALE FL 33312

BLUE SIGN/ RS232
ECDIS CABLE ASSEMBLY

ACR P/N 2644

SCALE 2:3

4

3

2

1

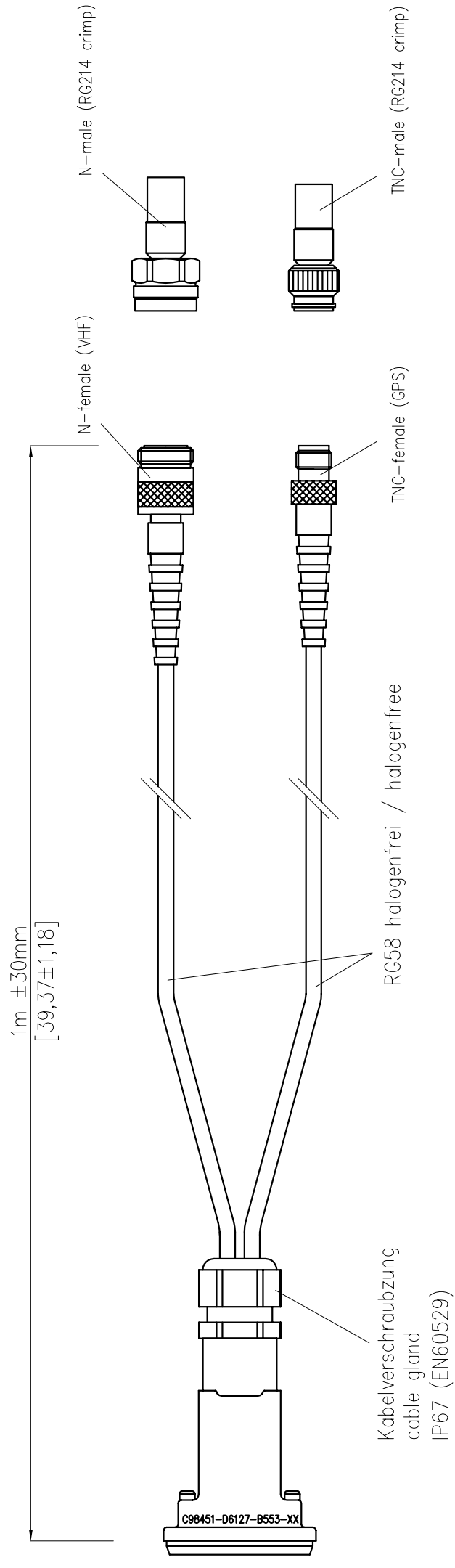

Stromlaufplan
circuit diagram

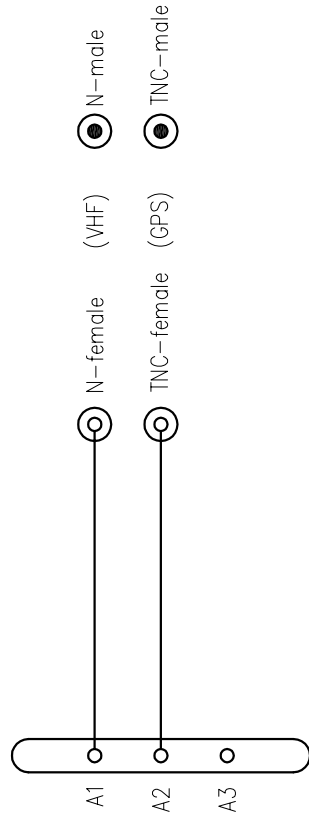

NOTES:

1. Mating connectors for cable are A1-03-0339 (TNC Male) and A1-03-0337 (N male) RG214 Crimp connectors.
2. Items 4, 5 and 6 to meet ENG60945 for:
 - Dust & water IP 67
 - Salt spray test
 - Corrosion resistance

Id-No.: 2600653

DISTANCE FROM MAGNETIC COMPASS		CAD	
STANDARD TYPE: ...m		STEERING TYPE: ...m	
mm		[INCH]	
DATE		DATE	
DR 29.04.2003		DP	
ACCEPTED AL 20.05.2003			
ACR Electronics		ACR Electronics	
5757 Ravenswood Road		5757 Ravenswood Road	
Fort Lauderdale, FL 33312		Fort Lauderdale, FL 33312	
1	20.05.03		
LTR	REVISIONS	DATE	
SCALE -		WEIGHT: 0,2 Kg	
DRAWING TITLE			
Maßzeichnung / DIMENSIONAL DRAWING			
FOR			
GPS/VHF cable for extension N TNC			
2612			

THIS DOCUMENT AND THE DATA ENCLOSED HEREIN OR HEREWITH IS PROPERTY OF ACR ELECTRONICS INC. AND IS TO BE USED SOLELY FOR INFORMATIONAL PURPOSES. IT IS NOT TO BE REPRODUCED, USED, OR DISCLOSED IN WHOLE OR IN PART TO ANYONE WITHOUT THE PERMISSION OF ACR.

10m ± 30mm

SCHEMATIC

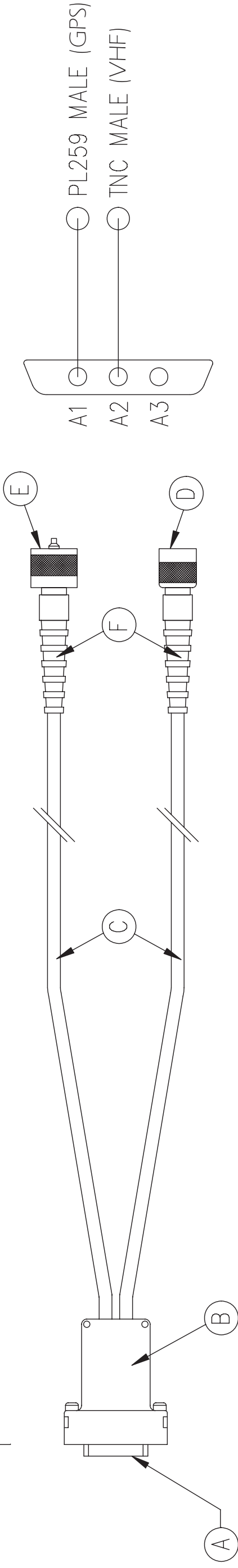

NOTES

- 1.) A3 CONNECTION IS LEFT OPEN W/NO PIN
- A. A1+A2 ARE DIN COAXIAL CONNECTORS IN A 15 PIN SOCKET (FEMALE) SHELL W/ 4/40 JACK SCREWS.
- B. PROTECTION COVERING, BLACK, PLASTIC
- C. BEDEA COAX 11710500 OR RG58 C/U MIL STD 17F OR EQUIV.
- D. TNC MALE CONNECTOR, AMPHENOL CONNEX # 122108 OR EQUIV.
- E. PL259 MALE CONNECTOR, AMPHENOL CONNEX #182100 OR EQUIV.
- F. RUBBERIZED STRESS RELIEF BOOTS.

ACR ELECTRONICS INC
5797 RAVENWOOD RD., FT. LAUDERDALE FL 33312

GPS/VHF Interface Cable,
10 meters

DRAWING NO. 2613

SCALE NONE

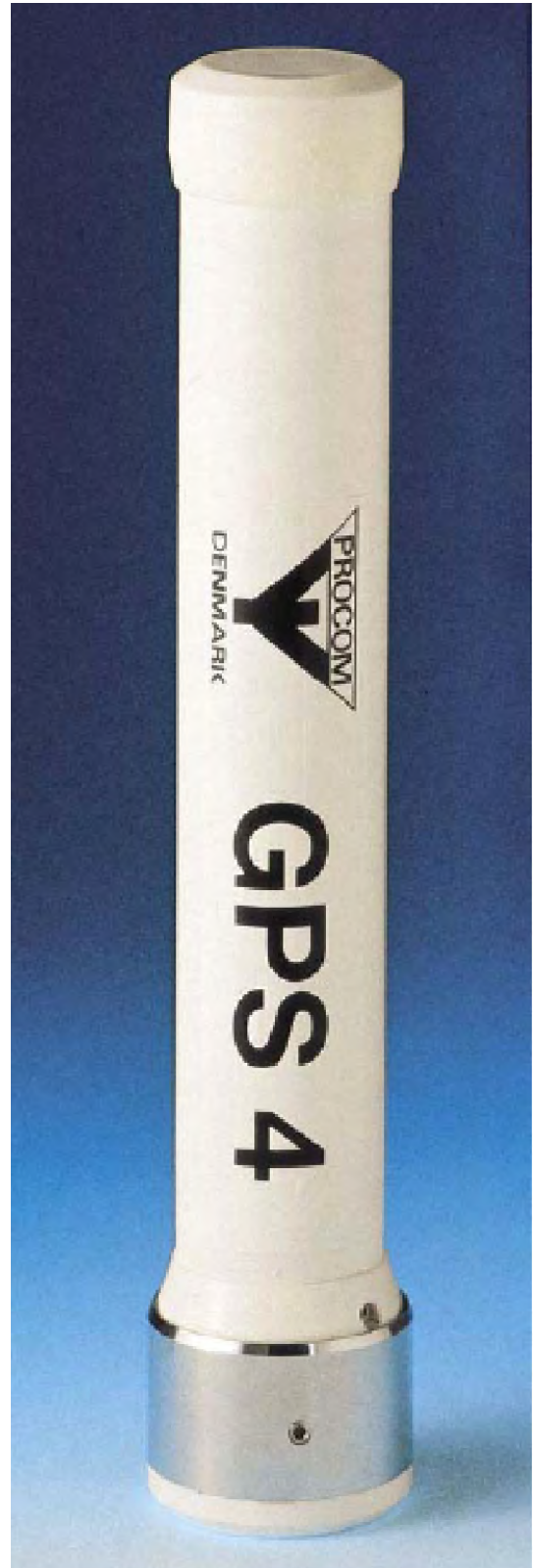
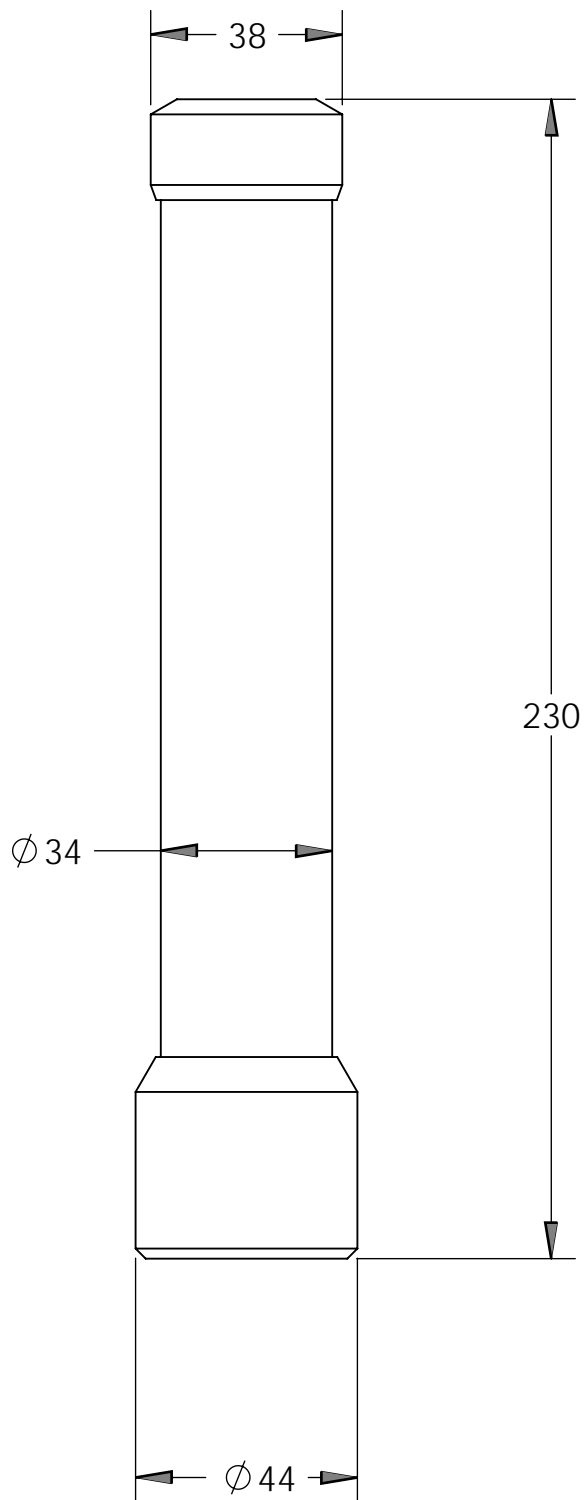

GPS 4 PROCOM RECEIVING ANTENNA

DRAWING NO. 2622

SCALE 1:2

1

2

3

4

THIS DOCUMENT AND THE DATA DISCLOSED HEREIN OR HEREWITH IS PROPERTY OF AND BELONGS TO ACR ELECTRONICS, INC. IT IS FURNISHED IN CONFIDENCE AND IS NOT TO BE REPRODUCED, COPIED, OR DISCLOSED IN WHOLE OR IN PART TO ANYONE WITHOUT THE PERMISSION OF ACR.

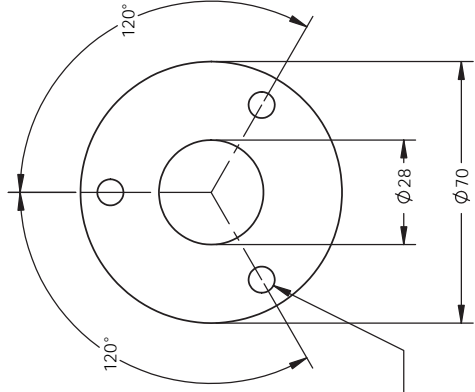
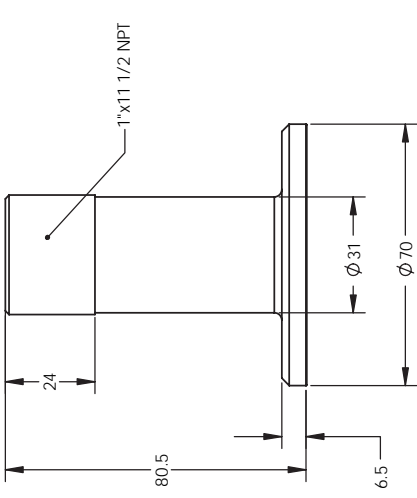

ITEM 3

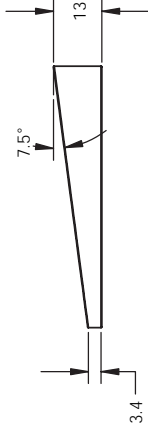

ITEM 4

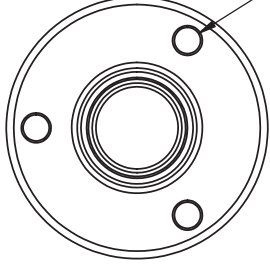

ITEM 5

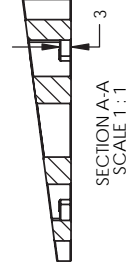

SECTION A-A
SCALE 1:1

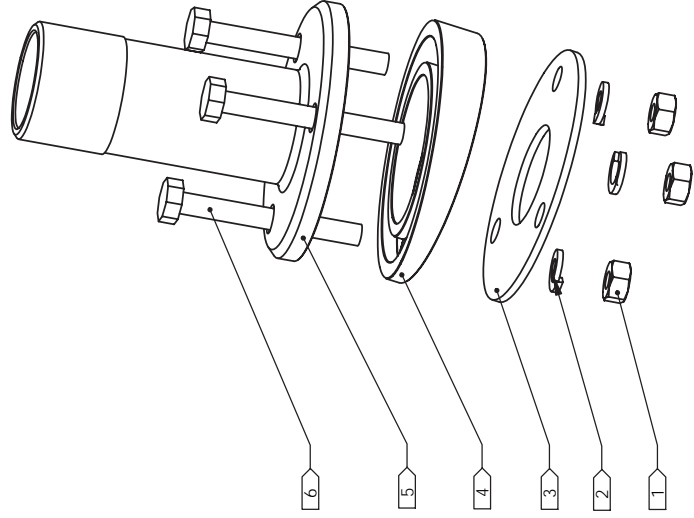

- 1 > M6X1.0 HEX NUT, STAINLESS STEEL
- 2 > M6 SPLIT LOCK WASHER, STAINLESS STEEL
- 3 > FITTING, RUBBER
- 4 > TAPERED SPACER, UV-STABILIZED PLASTIC
- 5 > FLANGE, TRIPLE-CHROMED SOLID BRASS
- 6 > M6X1.0X50 HEX HEAD SCREW

ACR ELECTRONICS, INC <small>5750 WOODBURN BLVD. LAUDERDALE, FL 33054</small>
ANTENNA MOUNT W/ HRDWRE METAL GPS4
ACR P/N 2623
SCALE 1:2

1

2

3

4

A

Electrical Specifications:

Dielectric Antenna
Center Frequency 1575.42MHz±3 MHz
V.S.W.R 1.5:1
Band Width ±5 MHz
Impedence 50 ohm
Peak Gain > 3dBic Based on 7×7cm ground plane
Gain Coverage > -4dBic at -90°<0<+90°
(over 75% Volume)
Polarization RHCP

LNA/Filter

A3-06-2539 LNA Gain without cable 28 dB Typical
A3-06-2539-1 LNA Gain with cable 17 dB to 20 dB
Noise Figure 1.5dB
Filter Out Band Attenuation (f0=1575.42 MHz)
7dB Min f0+/-20MHZ
20dB Min f0+/-50MHZ
30dB Min f0+/-100MHZ
V.S.W.R < 2.0
DC Voltage 5.0V
DC Current Nominal 11mA

Mechanical

Weight < 140gram
Size Ø96×126mm
Cable RG58
Connector TNC Male
Mounting M24×1.5
Housing white

Environmental

Working Temp -40°C ~ +85°C
Storage Temp. -45°C ~ +100°C
Vibration Sine sweep 1g(0-p)10~50~10Hz each axis
Humidity 95%~100%RH
Weatherproof 100%Waterproof



28dB Gain



20dB Gain

ACR ELECTRONICS INC.

Marine BBT Active GPS Antennas
w/5 Meter Coax & TNC Male Connector
2637 (28dB Gain) or 2639 (20dB Gain)

MOUNTING OPTIONS FOR GPS ANTENNA

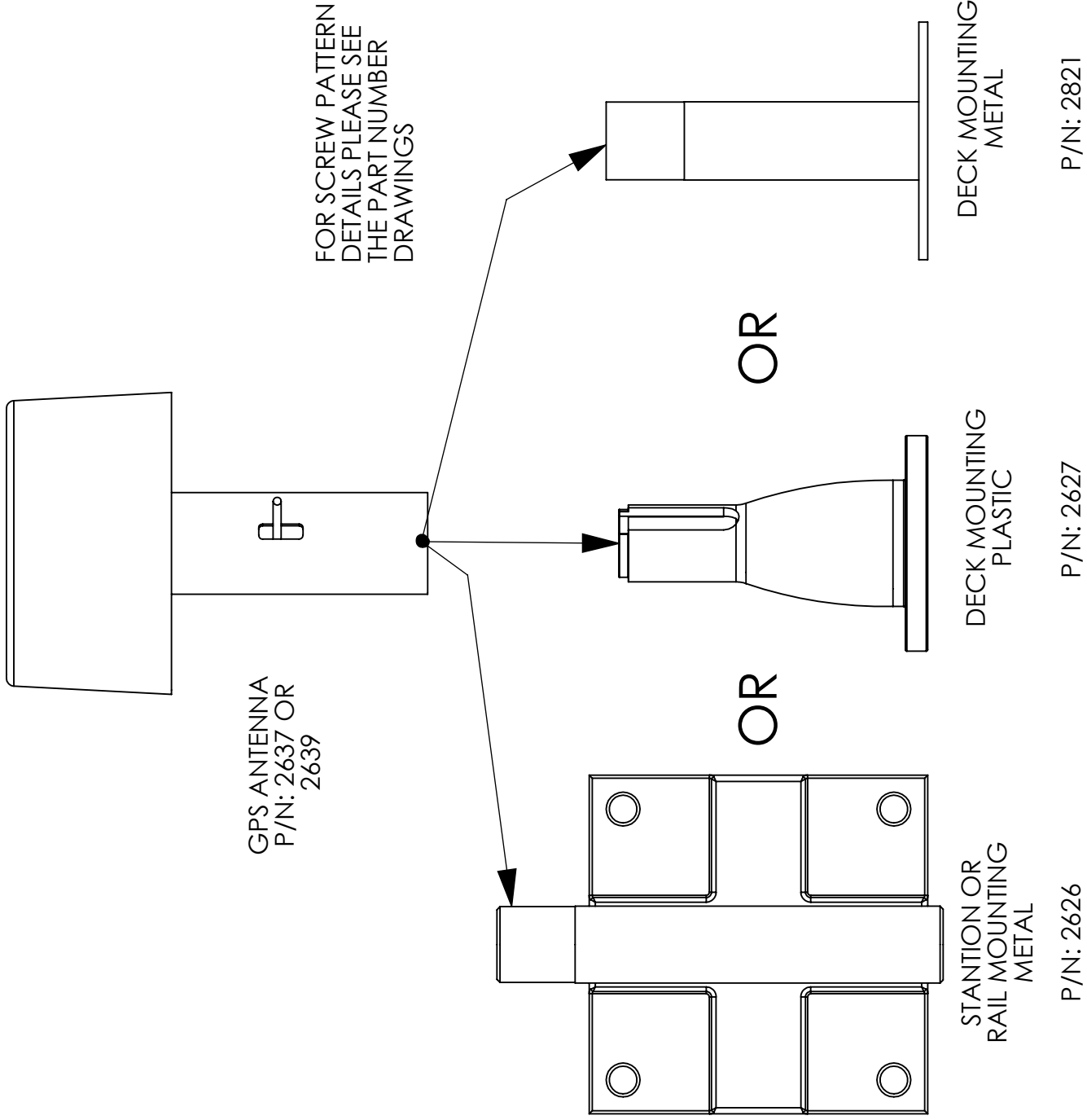

THIS DOCUMENT AND THE DATA DISCLOSED HEREIN OR HEREWIthin IS PROPERTY OF ACR AND BELONGS TO ACR ELECTRONICS, INC. IT IS TO BE USED ONLY FOR INFORMATIONAL PURPOSES. IT IS NOT TO BE REPRODUCED, USED OR DISCLOSED IN WHOLE OR IN PART TO ANYONE WITHOUT THE PERMISSION OF ACR.

1

D

C

B

A

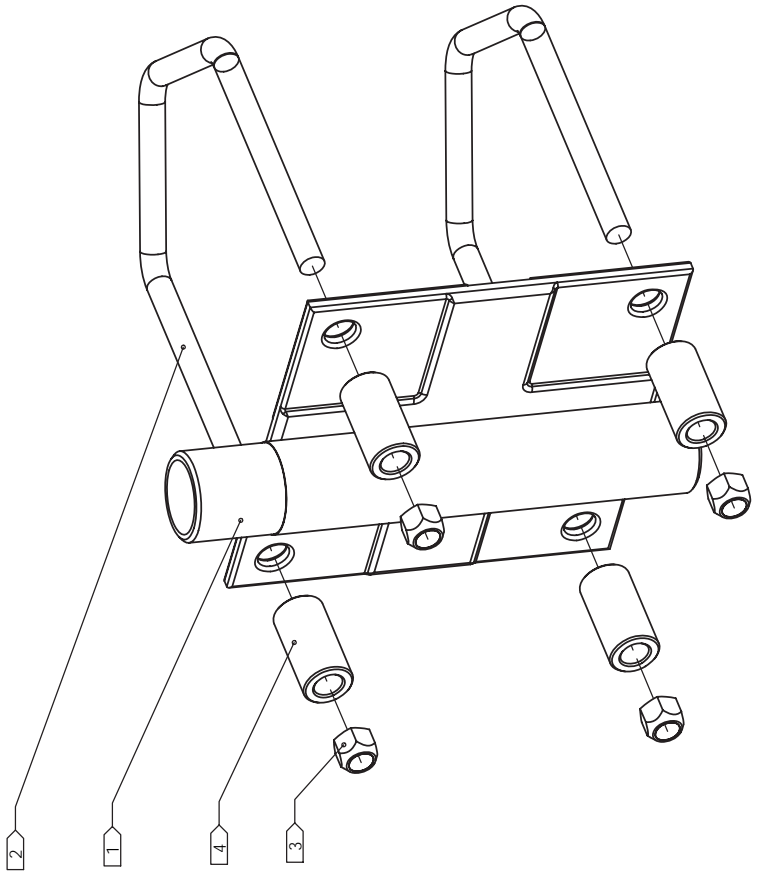

- 1 PIPE MOUNTING BRACKET
- 2 U SHAPED SCREW
- 3 M8X1.25 HEX LOCKNUT
- 4 SPACERS

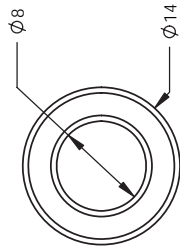
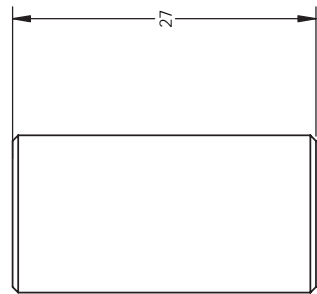
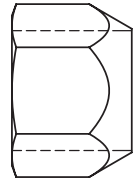
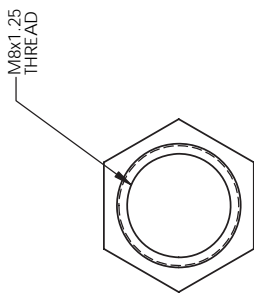

- NOTES:
1. GLOMEX
P/N: V9171
 2. MATERIAL: STAINLESS STEEL
 3. FINISH: ELECTRO POLISHED
 4. ITEMS COME TOGETHER IN A BOX

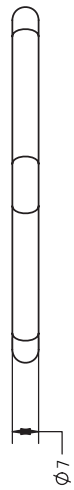
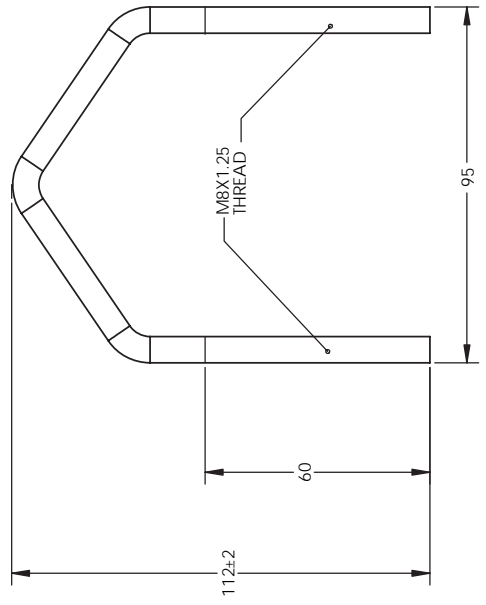
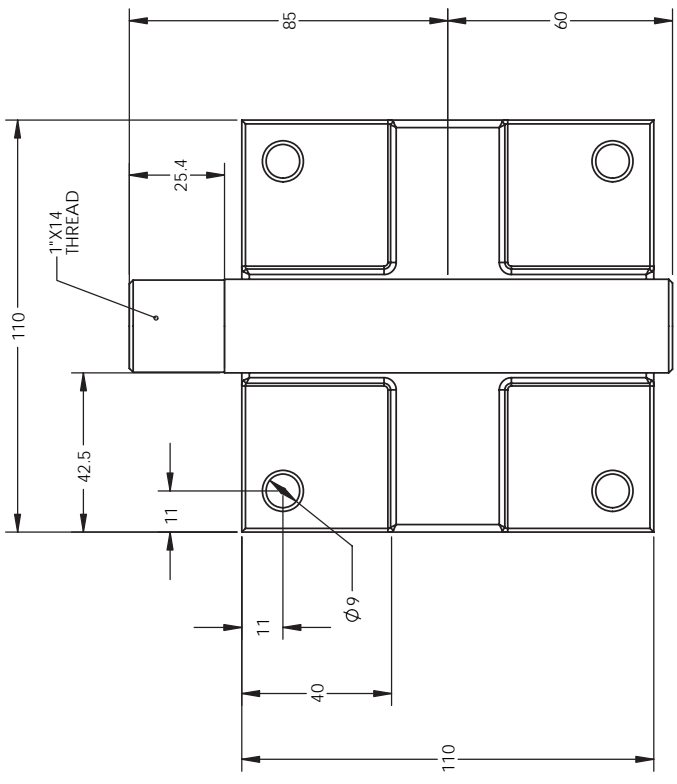
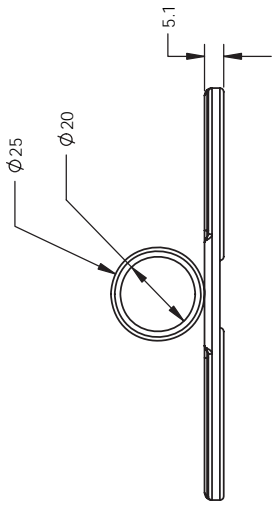

SPECIFICATION CONTROL DRAWING

ACR ELECTRONICS, INC
5757 RAVENSWOOD RD. FT. LAUDERDALE FL 33312

ANTENNA MOUNT
METAL, GPS

2626
SCALE: 1:1

1

2

3

4

5

6

7

8

1

2

3

4

D

C

B

A

THIS DOCUMENT AND THE DATA DISCLOSED HEREIN OR HEREWITH IS PROPERTY OF AND BELONGS TO ACR ELECTRONICS, INC. FT. LAUDERDALE, FL. IT IS FURNISHED IN CONFIDENCE SOLELY FOR INFORMATIONAL PURPOSES. IT IS NOT TO BE REPRODUCED, USED OR DISCLOSED IN WHOLE OR IN PART TO ANYONE WITHOUT THE PERMISSION OF ACR.

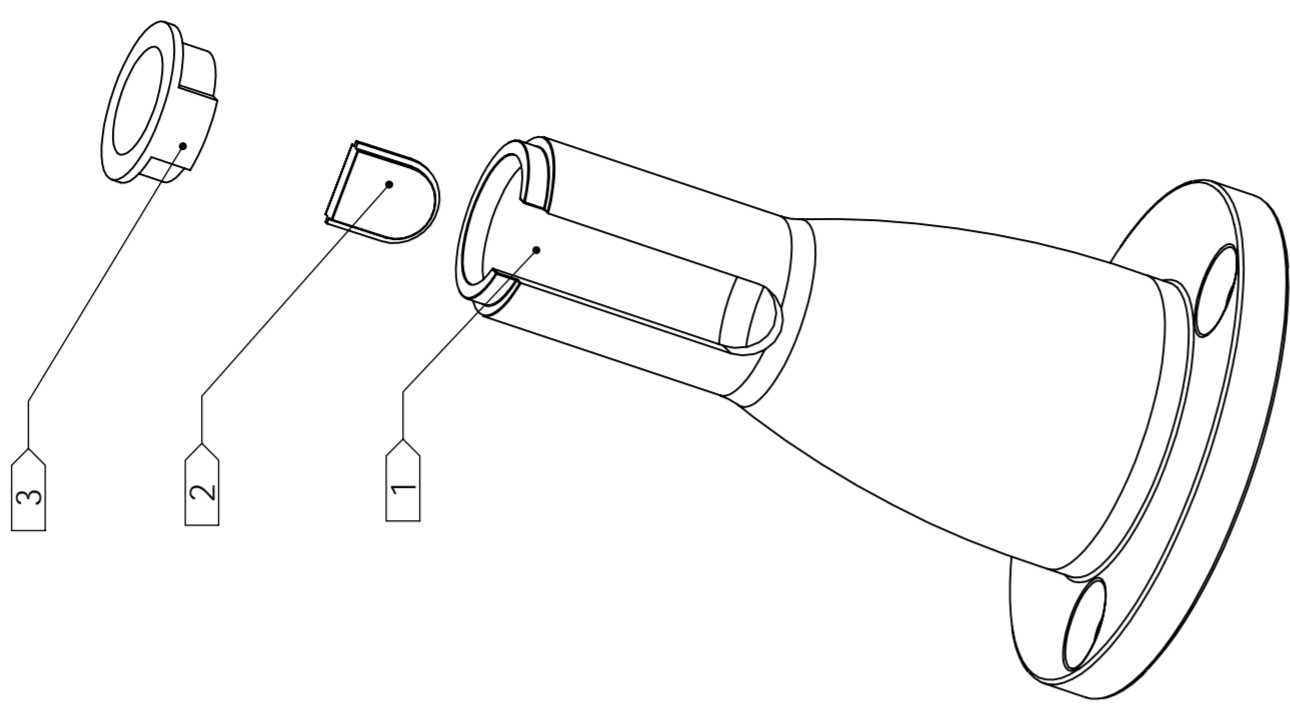
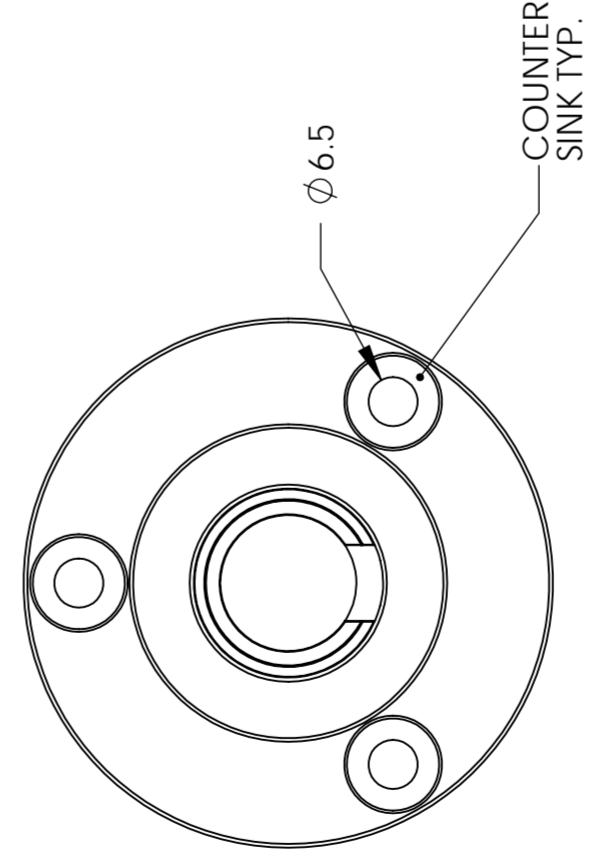
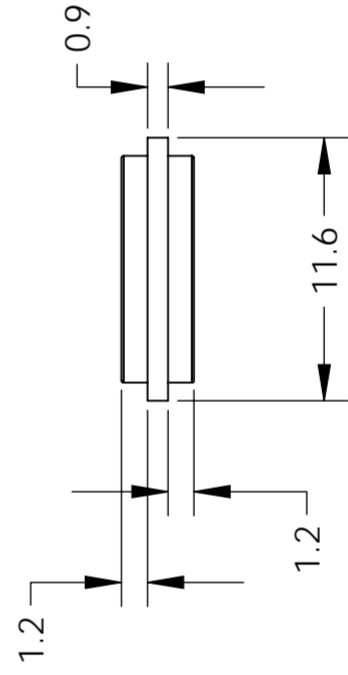
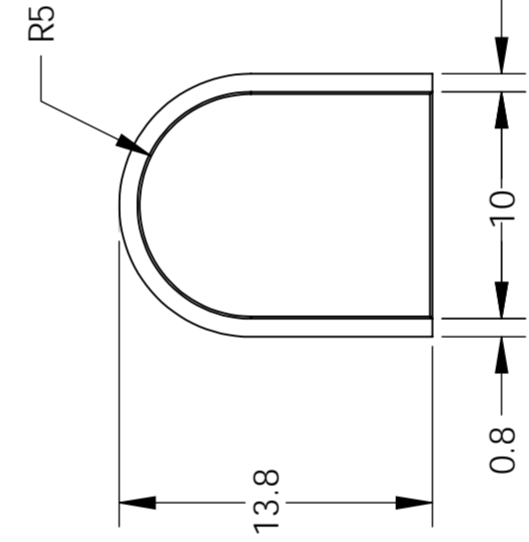
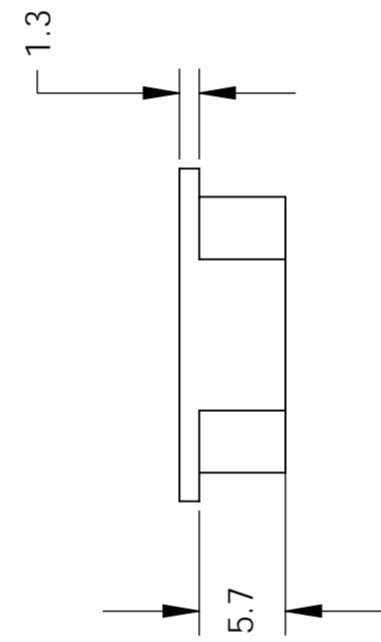
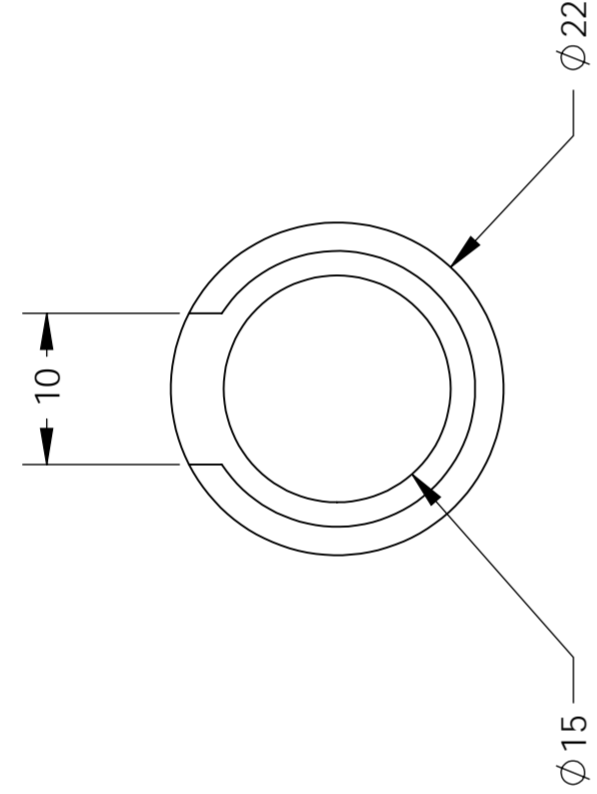
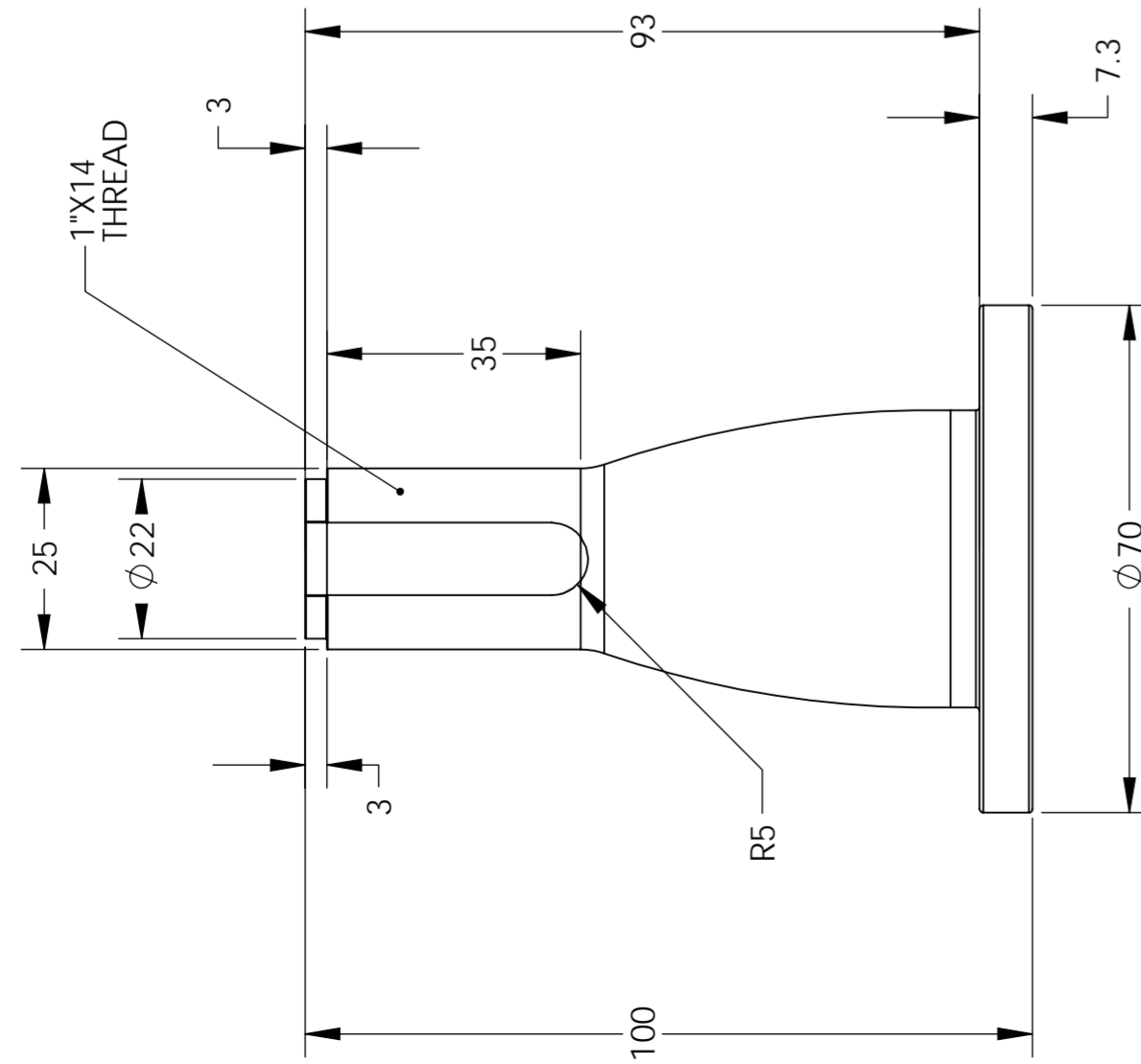

- 1 MOUNT BASE
- 2 CABLE TAB
- 3 STIFFENER RING

NOTES:

1. GLOMEX
P/N: V9175
2. MATERIAL: NYLON
3. COLOR: WHITE
3. ITEMS COME INDIVIDUALLY PACKAGED

ACR ELECTRONICS, INC
9757 RAVENSWOOD RD. FT. LAUDERDALE, FL. 33312

GPS MOUNT - PLASTIC

DRAWING NO. 2627

SCALE 1:1

1

2

3

4

THIS DOCUMENT AND THE DATA DISCLOSED HEREIN OR HEREWITH IS PROPERTY OF AND BELONGS TO ACR ELECTRONICS, INC. FT LAUDERDALE, FL. IT IS FURNISHED IN CONFIDENCE SOLELY FOR INFORMATIONAL PURPOSES. IT IS NOT TO BE REPRODUCED, USED OR DISCLOSED IN WHOLE OR IN PART TO ANYONE WITHOUT THE PERMISSION OF ACR.

NOTES:

- 1. MATERIAL: 304 STAINLESS STEEL
- 2. FINISH: POLISHED

B

B

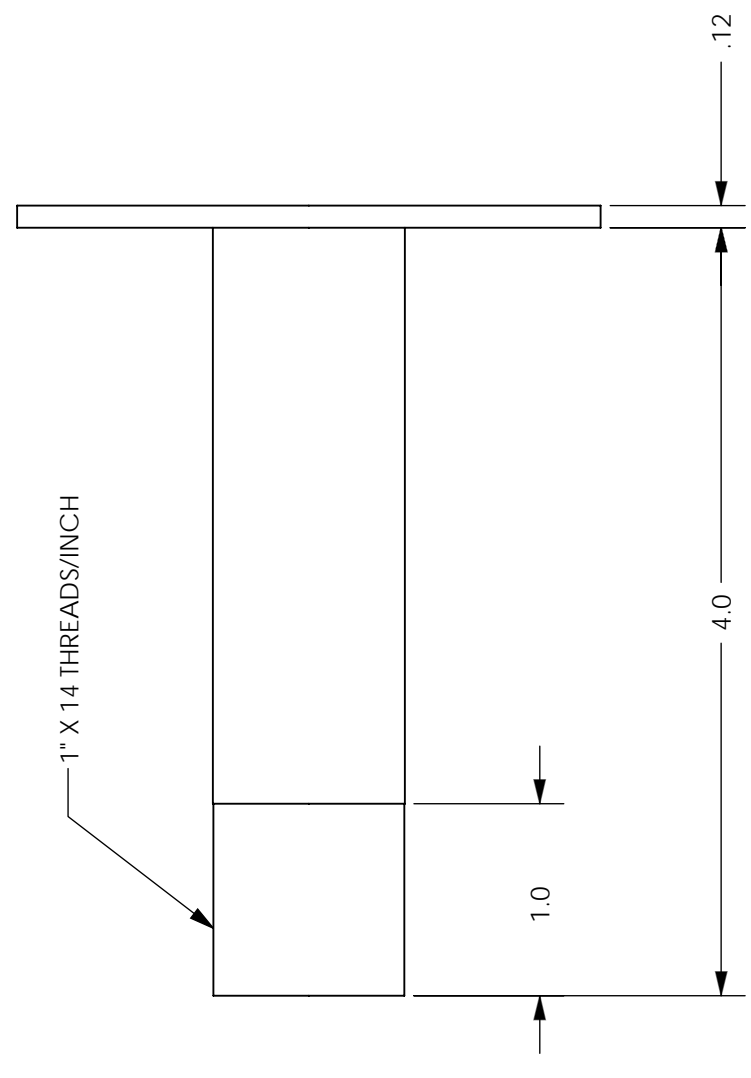
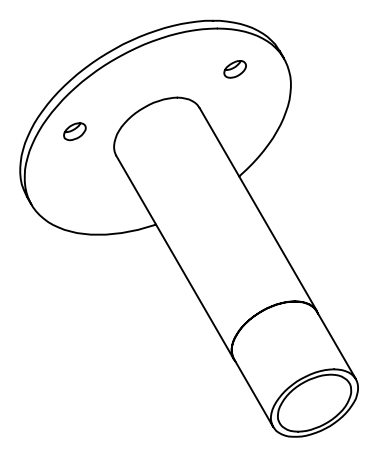
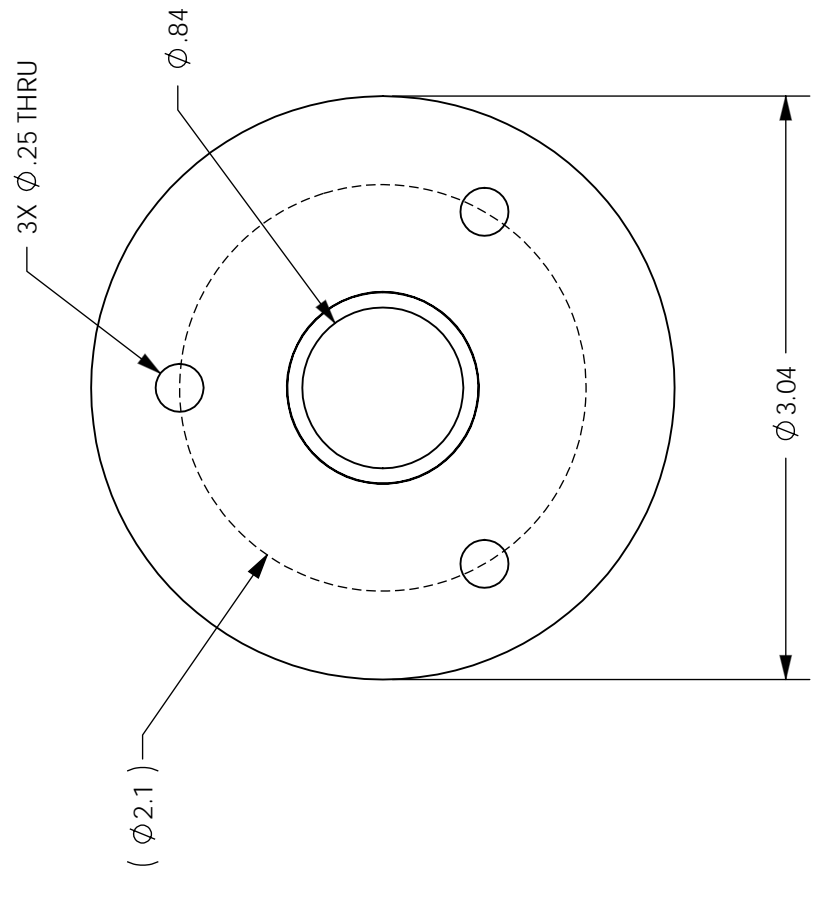

A

A

SPECIFICATION CONTROL DRAWING

ACR ELECTRONICS, INC 5757 RAVENSWOOD RD. FT. LAUDERDALE FL. 33312
GPS Deck Mount Metal 1 x 14 thread
DRAWING NO. 2821
SCALE 1:2

4

3

2

1

4

3

2

1

Antenna Width Dimensions:

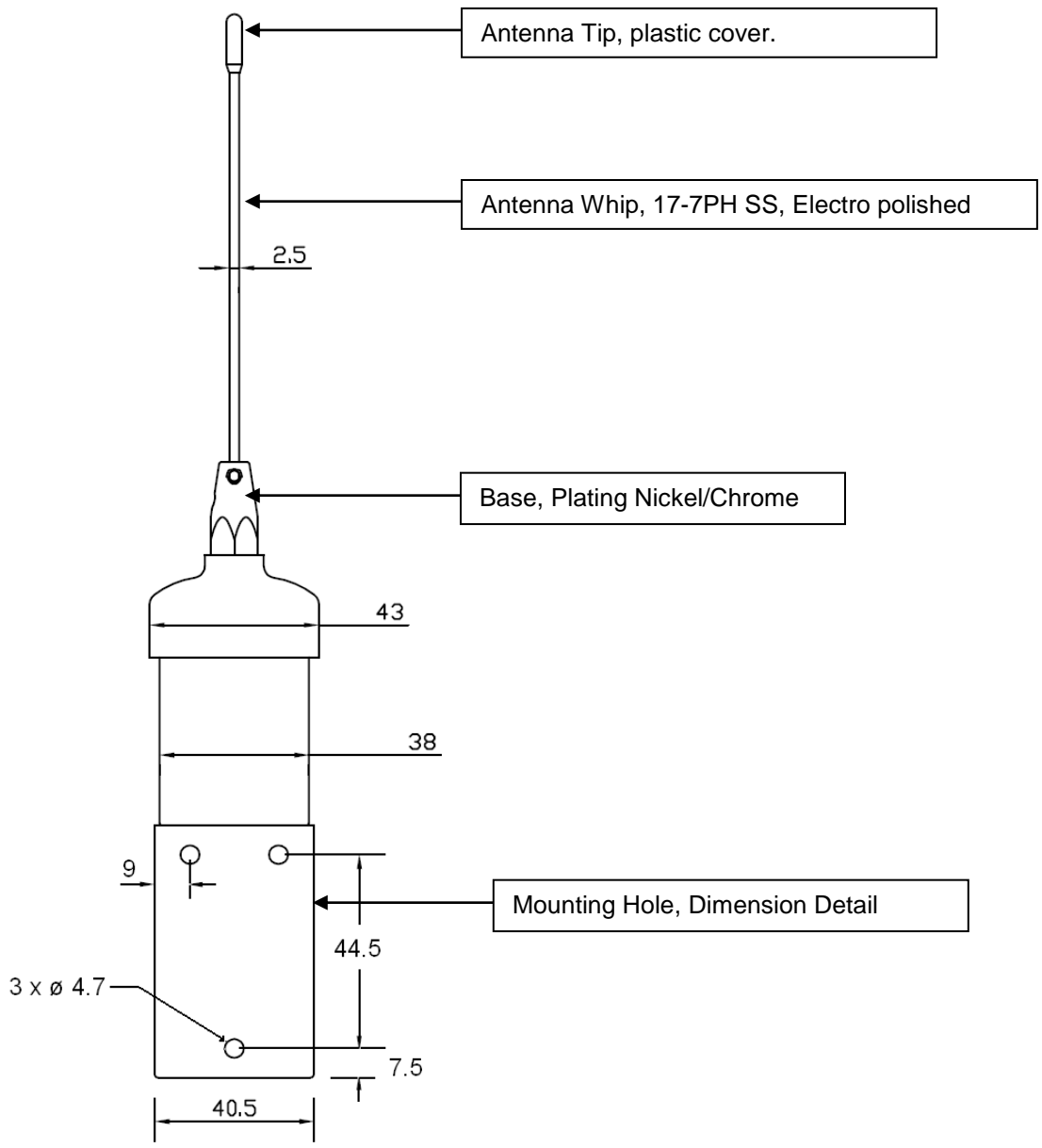

ACR ELECTRONICS INC.

5757 Ravenswood Road
Fort Lauderdale, FL 33312

SHEET

-1-

ACR PART NUMBER

2628

Antenna Dimension and Part Description:

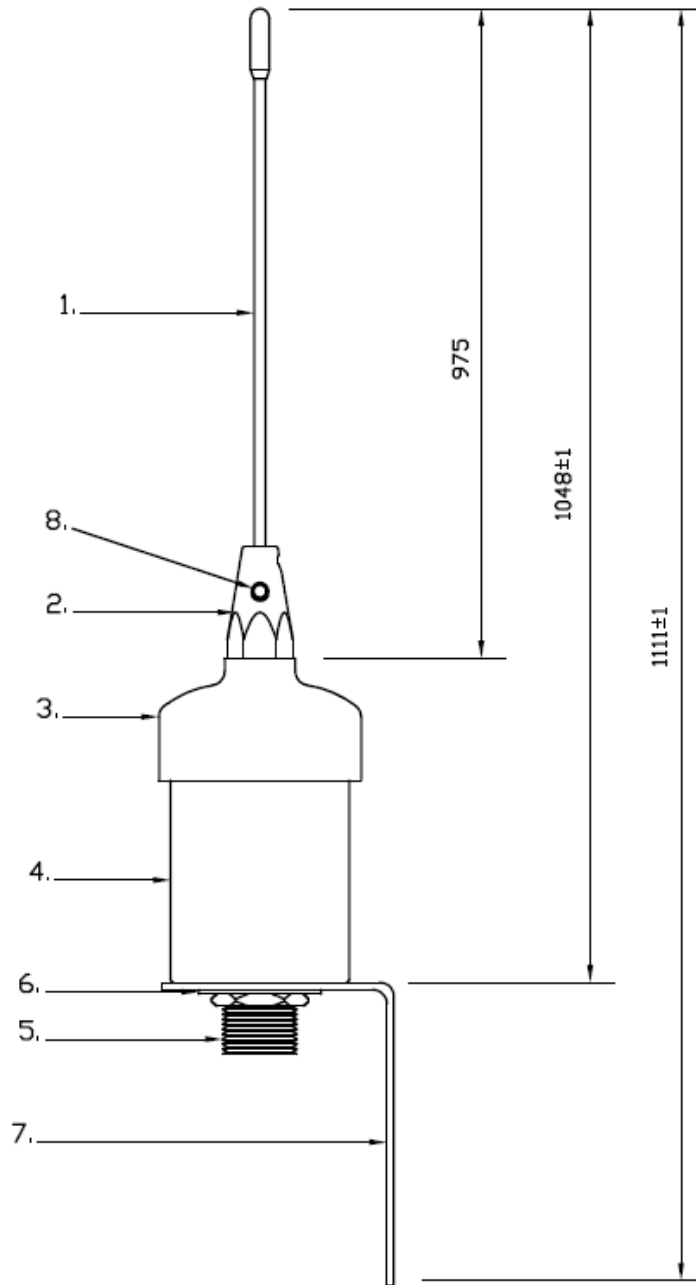

Part Descriptions:

- 1.) Antenna Whip
- 2.) Base of whip
- 3.) Coil housing cover – White nylon.
- 4.) Coil housing – Aluminum White.
- 5.) Antenna Connector – SO-239, female.
- 6.) Locking washer and nut.
- 7.) Mounting bracket
- 8.) Set screw x2.

ACR ELECTRONICS INC.

5757 Ravenswood Road
Fort Lauderdale, FL 33312

SHEET

-2-

ACR PART NUMBER

2628

TECHNICAL DATA:

Electrical specifications:

Frequency range	VHF: 156-162 MHz, VSWR <2 :1 GPS: 1575.42MHz, L1
Nominal impedance	50 ohm
Power rating	VHF: 25 W
Gain	VHF: 1 dBi GPS: +24dBic
Polarization	VHF: Vertical GPS: RHCP
Power GPS	2 – 5.6V DC feed through the coax. cable, 16mA + center, -outer conductor
Noise figure, GPS amp.	1.2dB maximum
Connector	N female
Cable length between antenna and filter	RG214 : 40m maximum RG58 : 20m maximum

Mechanical specifications:

Design	VHF: Centerfed coaxialdipole. GPS: Active Quad helix
	Radiating elements completely enclosed in polyurethane foam within a fiberglass tube.
Height	0,97m
Weight	0,5 kg
Wind rating	55 m/s = 125 mph
Finish	Polyurethane lacquer, white
Temperature range	-40°C, +50°C;+ -28 °F, +122°F

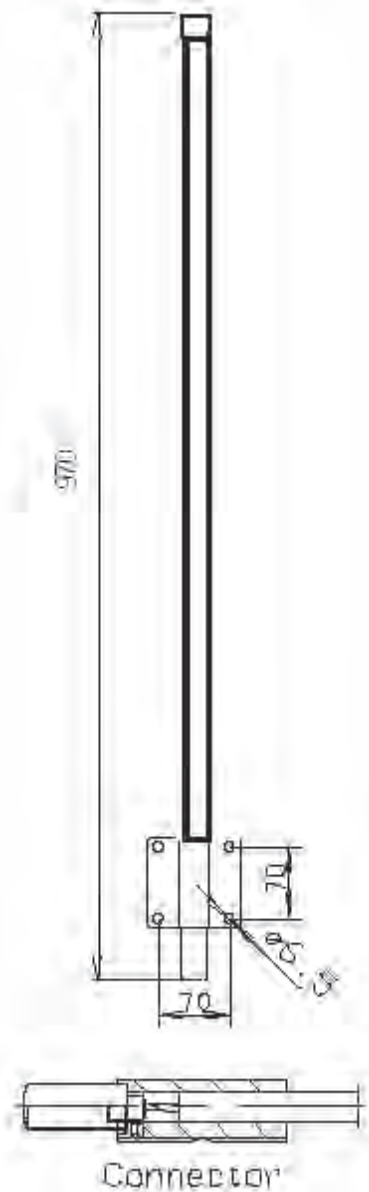
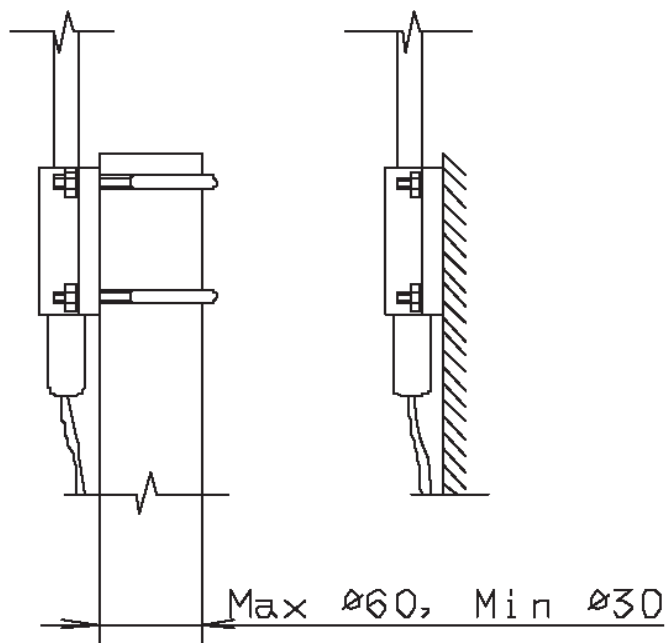

Antenna VHF GPS Combo

DRAWING NO. 2624

ACR Electronics, Inc.

SCALE 1:1

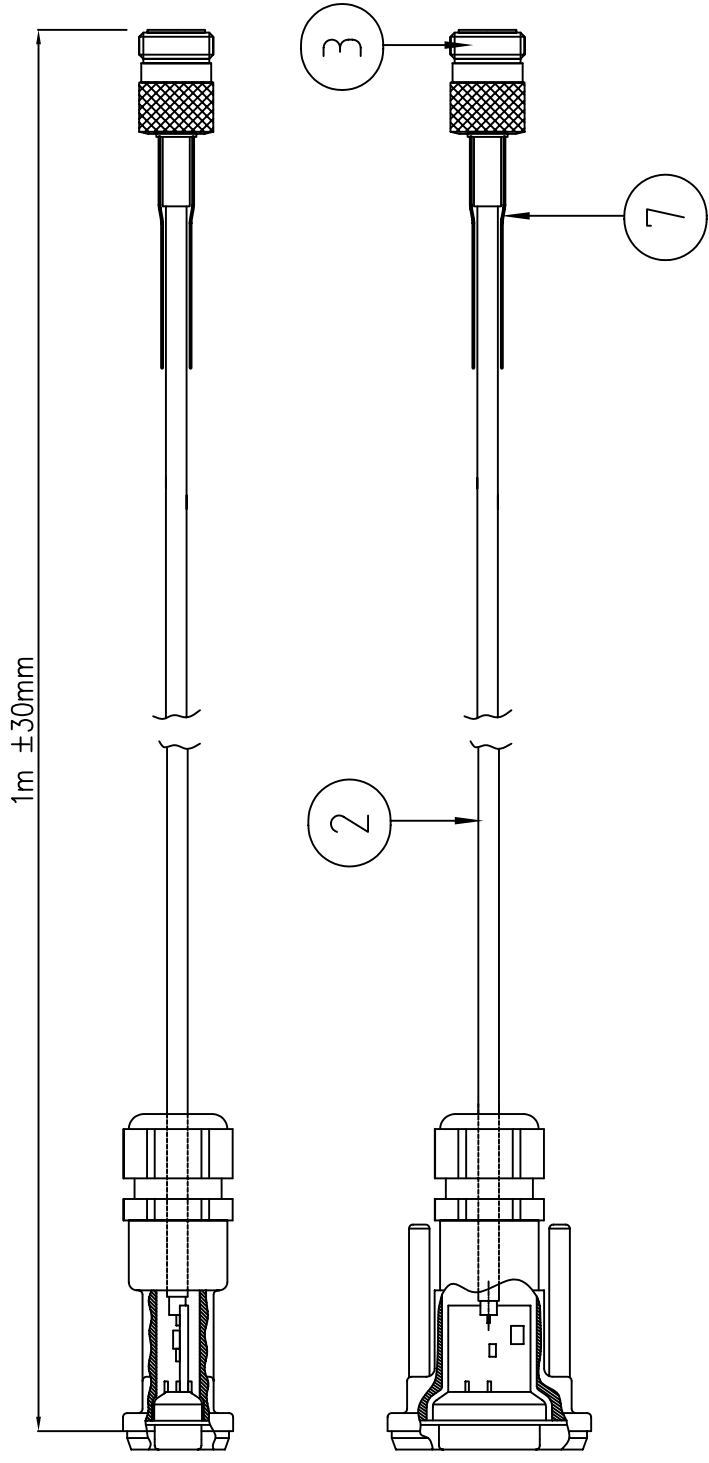

schematic diagramm

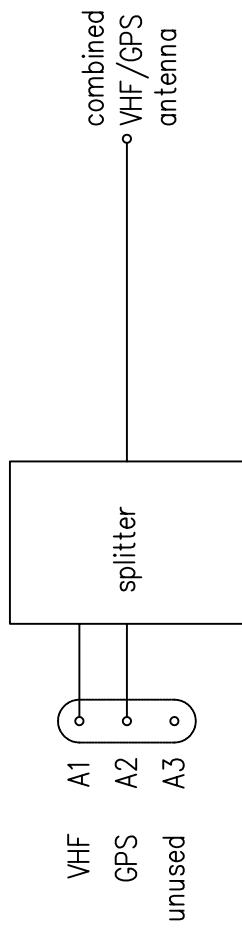

Electric specifications
 VHF - VHF/GPS antenna : <-0,5db @158MHz
 VHF - GPS : <-35db @158MHz
 GPS - VHF/GPS antenna : <-2,5db @1575MHz

remark:
 items 2 og 3 will not meet the EN60945 environment requirements as:
 -protection IP67
 -salt spray test
 -resistiveness to corrosion

delivery conditions:
 cable rolled up to a ring, packed into a PE-bag

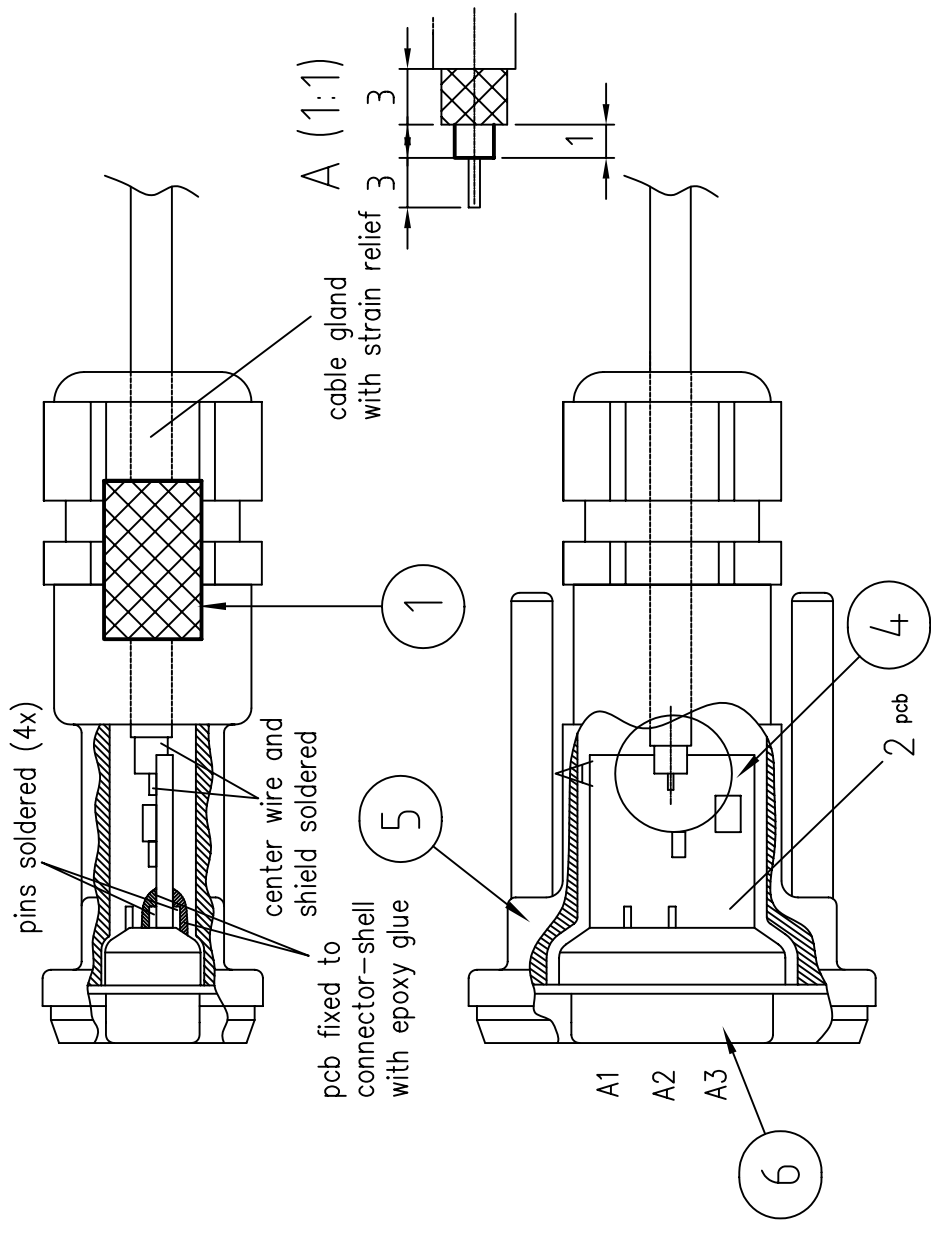

Lettering "C98451-D6127-B560-XX"
 size min. 2mm
 XX=release (2-digits) (example 01 is drawing release 01)

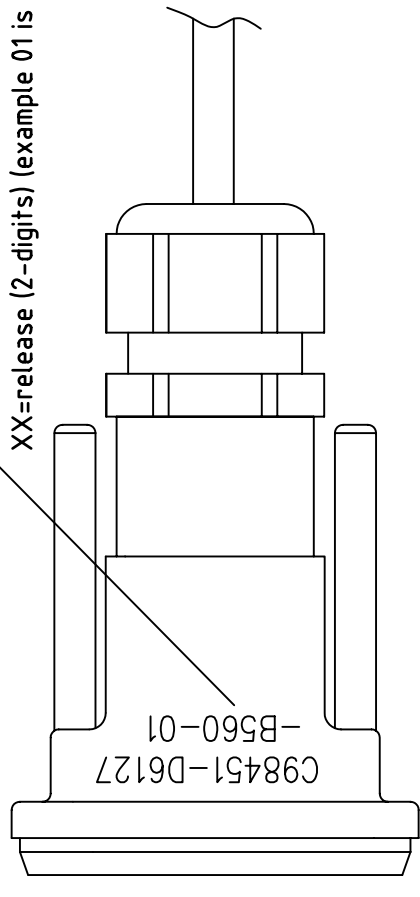

1	7	Krympselange $\phi 9/3$	ATUM	Kapplengde= 30mm
1	6	Koax. plugg		4.003W35XX76A10X fra CONEC
1	5	Vannfett hus		165x14829x fra CONEC
1	4	Printkort	AC17-AIS-MAR-IA-0001	Hunn
1	3	N-plugg full crimp		RG-58 sort L=960mm
1	2	Kabel		
5	1	Hylse	AC17-AIS-MAR-T-0001 POM	
Ant.	Pos	Navn	Tegn.nr.	Material
Dato	23.09.2003	Tegnet	ibe	Godkjent
				Målestokk
				1:2
				Erstatningfor
				Type /Dimensjon
				Erstattet av



AIS/F/Nauticast
 Sammenstilling

Included with ACR Part #2624

Side

Overflate

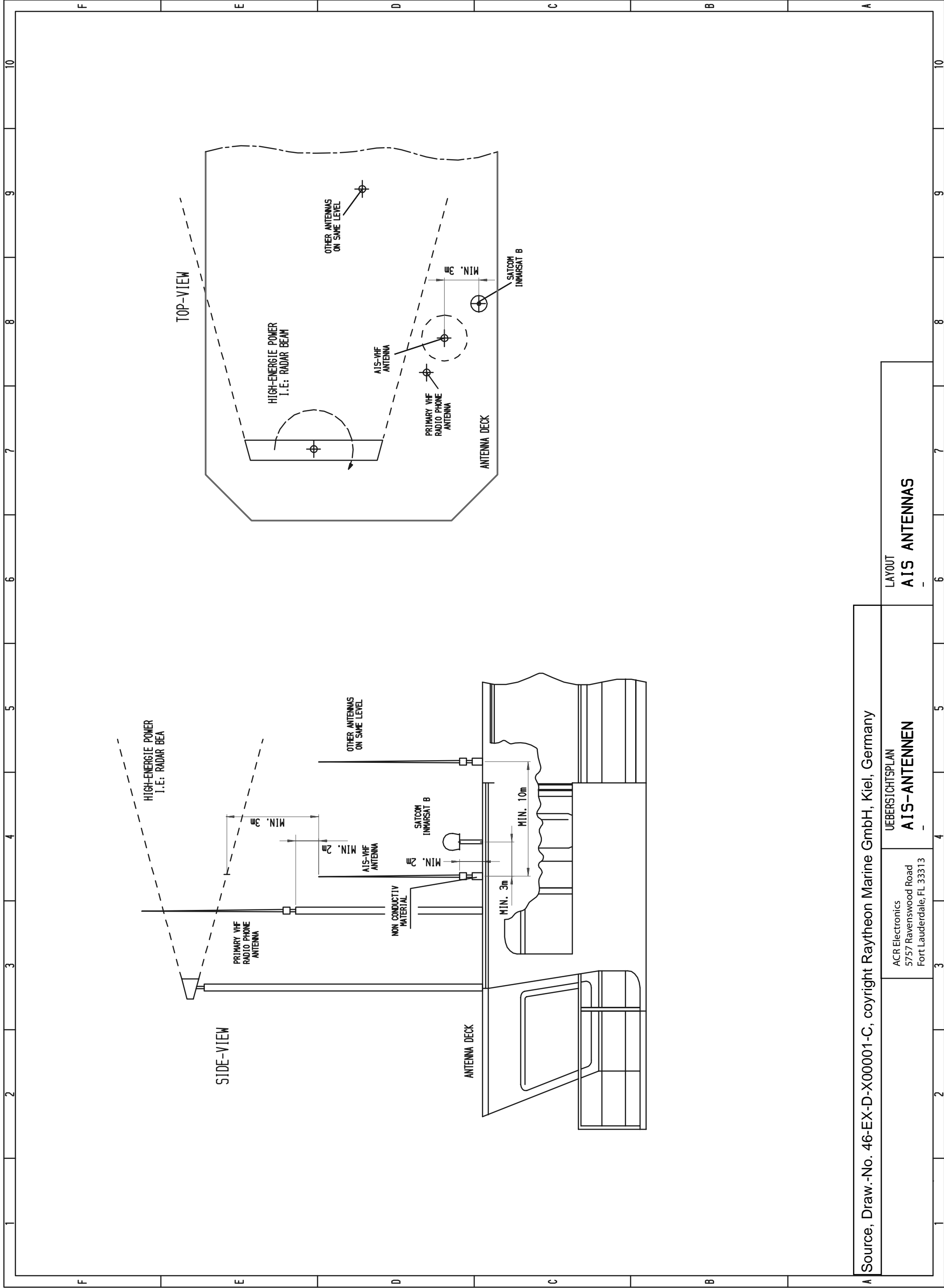

Für diese technische Unterlage behalten wir uns alle Rechte vor. For this technical document all rights reserved.

A Source, Draw.-No. 46-EX-D-X00001-C, copyright Raytheon Marine GmbH, Kiel, Germany

ACR Electronics
5757 Ravenswood Road
Fort Lauderdale, FL 33313

ÜBERSICHTSPLAN
AIS-ANTENNEN

LAYOUT
AIS ANTENNAS



Zulassungsurkunde

Type Approval Certificate

Nr.: R - 4 - 203

Gemäß dem von der Zentralkommission für die Rheinschifffahrt (ZKR) beschlossenen
In accordance with the regulation adopted by the Central Commission for the Navigation on the River Rhine (CCNR)

**Standard Schiffsverfolgung und Aufspürung in der Binnenschifffahrt,
Edition 1.01 vom 10.10.2007**

und den
and the

**Betriebs- und Leistungsanforderungen, Prüfmethode und geforderten
Prüfergebnissen gemäß Test Standard für Inland AIS, Edition 1.0 vom 31.5.2007**

wird das Inland AIS Bordgerät
the Inland AIS equipment

NAUTICAST Inland AIS

des Herstellers
of the manufacturer

ACR Electronics INC, 5757 Ravenswood Road, Fort Lauderdale, FL 33312, USA

bestehend aus
components necessary for operation

ACR NAUTICAST Inland AIS unit;

Part No.: Part No.: 2662; SW Version No.: V2.0.S116.xxxx

Minimum Keyboard and Display; internal

GPS antenna; Part No.: ProCom GPS4 P/N 2612 or equivalent

VHF antenna; Part No.: VH-3200 P/N 2628 or equivalent

als Inland AIS Gerät für die Binnenschifffahrt zugelassen.
has been approved as Inland AIS equipment for Inland Navigation.

Die Zulassung wird dem Antragsteller:
The type approval has been issued for the applicant:

ACR Electronics Europe GmbH, Handelskai 388/Top 632, 1020 Wien, Österreich
erteilt.

Die Zulassungsinhaberin hat jede Änderung dieses Gerätetyps der Fachstelle der WSV für
Verkehrstechniken mitzuteilen.

The manufacturer shall inform Fachstelle der WSV für Verkehrstechniken of any modification to the type tested products.

Fachstelle der WSV für Verkehrstechniken
Im Auftrag / *by order*

(Bober)

Koblenz, den 28.11.2008





Bundesrepublik Deutschland

Federal Republic of Germany

Bundesamt für Seeschifffahrt und Hydrographie

Federal Maritime and Hydrographic Agency



BUNDESAMT FÜR
SEESCHIFFFAHRT
UND
HYDROGRAPHIE

EC TYPE EXAMINATION (MODULE B) CERTIFICATE

This is to certify that:

Bundesamt für Seeschifffahrt und Hydrographie, specified as a "notified body" under the terms of „Schiffssicherheitsgesetz“ of 9. September 1998 (BGBl. I, p. 2860) modified last 17. October 2005 (BGBl. I, p. 2985), did undertake the relevant type approval procedures for the equipment identified below which was found to be in compliance with the Navigation requirements of Marine Equipment Directive (MED) 96/98/EC as modified by Directive 2002/75/EC.

Applicant **ACR Electronics Europe GmbH**
 Address **Mariahilfer Straße 50/2/11, 1070 VIENNA, AUSTRIA**

Manufacturer **ACR Electronics, Inc.**
 Address **5757 Ravenswood Road, FORT LAUDERDALE, FL-33312-6645, USA**

Annex A.1 Item (No & item designation) **4.32 / Universal automatic identification system equipment (AIS)**

Product Name **X-Pack DS**

Trade Name(s) **see page 2**

Specified Standard(s)

IMO MSC.74(69) Annex 3	IEC 61993-2 (2001)
ITU-R M 1371-1 (Class A)	IEC 61162-1 (2000), -2 (1998)
IALA Technical Clarifications of Rec. ITU-R M, 1371-1 (Edition 1.3)	IEC 60945 (1996)
ITU-R M.825-3	IEC 61108-1 (1996)
ITU-R M. 1084-3	

This certificate remains valid unless cancelled, expired or revoked.

Date of issue: 2006-05-08

Issued by: Bundesamt für Seeschifffahrt und Hydrographie
Bernhard-Nocht-Str. 78, 20359 Hamburg, Germany
Notified body 0735

Expiry date: 2009-04-30

Certificate No.: BSH/4612/4320296/06

This certificate consists of 2 pages.



by order

Schulz-Reifer
Schulz-Reifer



Components necessary for operation:

Components necessary for operation	Part No.	Remarks
X-Pack DS	NAU-A 002	Software-Version: 2.0x
Connection Box	NAU-B 401	
VHF antenna Glomex	NAU-B 610	or equivalent
VHF antenna Marine II	NAU-B 601	or equivalent

The internal GPS sensor of the X-Pack DS is used as a backup sensor for position reporting

Documentation:

User Manual: Version 1.0x dated: 2002-12
 Installation Manual: Version 1.0x dated: 2003-03

Trade names:

The equipment is also available under the following trade names:

		Nauticast part No. of AIS transponder unit:
Raytheon Marine	RM 808 AIS	NAU-A 023
ACR	GlobalWatch UAIS	NAU-A 051
Marine Technologies	Bridgemate AIS	NAU-A 061
ACR	Nauticast	NAU-A 007

Limitations on the acceptance or use of the product:

Places of production:

Notes:

The manufacturer shall inform Bundesamt für Seeschifffahrt und Hydrographie, as the notified body, of any modifications to the type-tested product(s) that may affect compliance with the requirements or conditions laid down for use of the product(s).

In case the specified regulations or standards are amended during the validity of this certificate, the product(s) must be re-certified before being placed on board vessels to which such amended regulations or standards apply.

The Mark of Conformity (wheelmark) may only be affixed to the type approved equipment, and a Manufacturer's Declaration of Conformity may only be issued, if the product quality system fully complies with the Marine Equipment Directive and is certified by a notified body against ANNEX B module D, E, or F of the Directive.

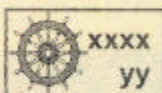
Example for the Application of the "Mark of Conformity":

xxxx number of the Notified Body responsible for quality surveillance module
 yy Last two digits of the year in which the mark is affixed.

Notice on legal remedies available:

Objection to this document may be filed within one month after notification. The objection must be filed in writing to, or put on record at, Federal Maritime and Hydrographic Agency, Bernhard-Nocht-Str. 78, 20359 Hamburg, Germany



Bundesrepublik Deutschland

Federal Republic of Germany

Bundesamt für Seeschifffahrt und Hydrographie

Federal Maritime and Hydrographic Agency



BUNDESAMT FÜR
SEESCHIFFFAHRT
UND
HYDROGRAPHIE

EC QUALITY SYSTEM (MODULE D) CERTIFICATE

Bundesamt für Seeschifffahrt und Hydrographie (Federal Maritime and Hydrographic Agency) as the notified body performing EC conformity assessment procedures in compliance with EC Council Directive 96/98/EC of 20 December 1996 on Marine Equipment, last amended by EC Commission Directive 2002/75/EC of 2 September 2002, hereby certifies that a quality system in accordance with the requirements of the Maritime Equipment Directive Annex B, Module D is maintained and applied by the manufacturer

Applicant :

ACR Electronics Inc.
5757 Ravenswood Road
Ft. Lauderdale, FL 33312
USA

Scope:

- A.1/4.18 9 GHz SAR transponder (SART)
- A.1/4.32 Universal automatic identification system equipment (AIS)
- A.1/5.6 406 MHz (COSPAS-SARSAT)

References: see overleaf

Date of issue: 2007-04-02

Issued by: Bundesamt für Seeschifffahrt und Hydrographie, Hamburg

Expiry date: 2010-04-01

Identification number 0735

Registration no.: BSH/4613/05101/0555/07

This certificate consists of 2 pages



by order

Eckert



Places of production (if different from client or where there are several)

Restrictions:

Notes:

This certificate authorises in conjunction with the EC Type Examination (Module B) Certificate of the equipment listed in the scope to affix the "Mark of Conformity" (wheelmark).

This certificate loses its validity if the manufacturer makes any changes or modifications to the approved quality system, which have not been notified to, and agreed with the notified body named on this certificate and/or after lapse of time, withdrawal or revocation of the EC Type Examination (Module B) Certificate.

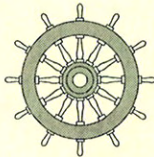
"Wheelmark" Format and application:**0735/yy**

example

yy Last two digits of the year in which mark is affixed.
0735 Notified Body number undertaking quality surveillance

Annex to
EC QUALITY SYSTEM (MODULE D) CERTIFICATE

No. BSH/4613/05101/0555/07



BUNDESAMT FÜR
SEESCHIFFFAHRT
UND
HYDROGRAPHIE

Item	Module B Certificate data				
	Registration number	date of issue	date of expiry	Notified Body	
	USCG Approval No.				
A.1/5.6	406 MHz Satellite EPIRB (COSPAS-SARSAT)				
	RLB-35	BSH/4612/5060372/06	2006-10-04	2011-10-03	0735
		---	---	---	---
	Global Fix 406	4612/5060016/2005	2005-03-15	2010-03-14	0735
		---	---	---	---
	Satellite ₂ 406	6492/050564-1/2004	2004-12-20	2009-12-19	0735
		---	---	---	---
	Rapid Fix 406	6492/050564-2/2004	2004-12-20	2009-12-19	0735
		---	---	---	---
	RLB-36	BSH/4612/5060959/08	2008-09-19	2013-09-18	0735
		---	---	---	---
A.1/4.32	Universal automatic identification system				
	X-Pack DS	BSH/4612/4320296/06	2006-05-08	2009-04-30	0735
		---	---	---	---
A.1/4.18	9 GHz SAR Transponder (SART)				
	ACR Pathfinder 3 SART	QQ-MED-22/08-01	2008-11-06	2013-11-05	0191
		---	---	---	---

Hamburg, 2008-11-19



Notice on legal remedies available:

Objection to this document may be filed within one month after notification. The objection must be filed in writing to, or put on record at, Federal Maritime and Hydrographic Agency, Bernhard-Nocht-Str. 78, 20359 Hamburg, Germany



EG - Konformitätserklärung EC - Declaration of Conformity

Diese Konformitätserklärung bestätigt, dass das unten benannte Produkt den Auflagen der EC Council Directive 96/98/EC vom 20 Dezember 1996 für maritime Ausrüstung, geändert durch die EC Council Directive 2002/75/EC vom 2. September 2002 entspricht und von der benannten Stelle Nr. 0735 (BSH) typengeprüft wurde. Darüber hinaus ist die Konformität gemäß Commission Regulation (EC) No. 415/2007 zum „Standard Schiffsverfolgung und Aufspürung in der Binnenschifffahrt, Edition 1.01 vom 10.10.2007“ sowie zum „Test Standard for Inland AIS Edition 1.0“ vom 31. May 2007 gewährleistet.

This declaration of conformity certifies that the specified equipment is in compliance with EC Council Directive 96/98/EC of 20 December 1996 on Marine Equipment (MED), as amended by Commission Directive 2002/75/EC of 2 September 2002. The Commission Regulation (EC) No. 415/2007 concerning Vessel Tracking and Tracing Systems on Inland Waterways, defined in the Test Standard for Inland AIS Edition 1.0 of 31st May 07 has been type examined.

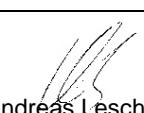
Produktbezeichnung: Product Name / Nom du produit	X-Pack DS (Inland AIS)
OEM Name: Trade Name / Marque Déposée	Nauticast™ Inland AIS
Zertifikate der benannten Stelle: Certificates from the notified Body / Certificats des Organismes Notifiés	EC Type Examination (Module B) Certificate: BSH/6412/4320296/06 EC Quality System (Module D) Certificate: BSH/4613/05101/0555/07 Issued by: Bundesamt für Seeschifffahrt und Hydrographie (BSH), Notified Body No. 0735 Bernhard-Nocht-Str. 78, 20359 Hamburg, Germany Inland AIS Type Approval Certificate No: R - 4 - 203 Issued by: Fachstelle der WSV für Verkehrstechniken Weinbergstraße 11-13, 56070 Koblenz, Germany
Spezifizierte Standards: Specified Standard(s) / Standard(s) Spécifié(s)	IMO MSC.74(69) Annex 3 ITU-R M.1371-3 (Class A) IALA Technical Clarifications of Rec. ITU-R M.1371-1 (Ed. 1.3) ITU-R M.825-3 ITU-R M1084-3 IEC 61993-2 (2001) IEC 61162-1 (2000), -2 (1998) IEC 60945 (1996) IEC 61108-1 (1996) Technical Specification for Vessel Tracking and Tracing Systems for Inland Waterways (Ed. 1.01 dated 10.10.2007) Test Standard for Inland AIS, (Edition 1.0 dated 31.5.2007)
Dokumentnummer: Document number / Num. du document	2008-08
Hersteller: Manufacturer / Fabricant	ACR Electronics Inc., 5757 Ravenswood Road, Fort Lauderdale, Florida, 33312 USA
Anschrift EU-Vertretung: Address EU-Representative / Adresse du Représentant pour l'UE	ACR Electronics Europe GmbH Handelskai 388 / Top 632 A-1020 Vienna, Austria
Ort, Datum: place, date / Lieu, Date	Vienna, 2008-12-04
Unterschrift: Signature / Signature	 Andreas Lesch Managing Director

Diese Erklärung bescheinigt die Übereinstimmung mit den genannten Richtlinien, ist jedoch keine Zusicherung von Eigenschaften. Die Sicherheitshinweise der mitgelieferten Produktdokumentation sind zu beachten.

This declaration certifies the compliance with the indicated directives but implies no warranty of properties. The safety instructions of the accompanying product documentation shall be observed.

Cette déclaration certifie la conformité avec les directives indiquées mais n'implique aucune garantie des propriétés. Les instructions de sécurité de la documentation accompagnant le produit doivent être suivies.

ISO 9001:2000 Zertifizierung / ISO 9001:2000 Certification

ACR Electronics Europe GmbH hat ein Qualitätsmanagement System nach ISO 9001:2000 implementiert, und ist seit Juli 2003 ISO-zertifiziert.

ACR Electronics Europe GmbH maintains a Quality Management System according to ISO 9001:2000, and received ISO certification in July 2003.



EG - Konformitätserklärung EC - Declaration of Conformity

Diese Konformitätserklärung bestätigt, dass das unten benannte Zubehör gleich oder besser dem im untenstehenden Zertifikat ausgewiesenen Zubehör ist.

This declaration of conformity certifies that the mentioned accessory is equal or better to the equipment stated in the beyond Certificate.

Produktbezeichnung: Product Name / Nom du produit	X-Pack DS (Inland AIS)
OEM Name: Trade Name / Marque Déposée	Nauticast™ Inland AIS
Zertifikate der benannten Stelle: Certificates from the notified Body / Certificats des Organismes Notifiés	EC Type Examination (Module B) Certificate: BSH/6412/4320296/06 EC Quality System (Module D) Certificate: BSH/4613/05101/0555/07 Issued by: Bundesamt für Seeschifffahrt und Hydrographie (BSH), Notified Body No. 0735 Bernhard-Nocht-Str. 78, 20359 Hamburg, Germany Inland AIS Type Approval Certificate No: R - 4 - 203 Issued by: Fachstelle der WSV für Verkehrstechniken Weinbergstraße 11-13, 56070 Koblenz, Germany
Spezifizierte Standards: Specified Standard(s) / Standard(s) Spécifié(s)	IMO MSC.74(69) Annex 3 ITU-R M.1371-3 (Class A) IALA Technical Clarifications of Rec. ITU-R M.1371-1 (Ed. 1.3) ITU-R M.825-3 ITU-R M1084-3 IEC 61993-2 (2001) IEC 61162-1 (2000), -2 (1998) IEC 60945 (1996) IEC 61108-1 (1996) Technical Specification for Vessel Tracking and Tracing Systems for Inland Waterways (Ed. 1.01 dated 10.10.2007) Test Standard for Inland AIS,(Edition 1.0 dated 31.5.2007)
Zubehörtyp: Type of Accessory	Combined GPS/VHF Antenna Comrod AC17 combined GPS/VHF Antenna + Splitter (in Cable integrated)
ACR Part Number: Einschränkungen / Hinweise Restrictions / Comments	2624 Verlegte Kabellänge < 40m Installed Cable length <40m
Dokumentnummer: Document number / Num. du document	2008-09
Hersteller: Manufacturer / Fabricant	ACR Electronics Inc., 5757 Ravenswood Road, Fort Lauderdale, Florida, 33312 USA
Anschrift EU-Vertretung: Address EU-Representative / Adresse du Représentant pour l'UE	ACR Electronics Europe GmbH Handelskai 388 / Top 632 A-1020 Vienna, Austria
Ort, Datum: place, date / Lieu,Date	Vienna, 2008-12-05
Unterschrift: Signature / Signature	 Andreas Lesch Managing Director

Diese Erklärung bescheinigt die Übereinstimmung mit den genannten Richtlinien, ist jedoch keine Zusicherung von Eigenschaften. Die Sicherheitshinweise der mitgelieferten Produktdokumentation sind zu beachten.

This declaration certifies the compliance with the indicated directives but implies no warranty of properties. The safety instructions of the accompanying product documentation shall be observed.

Cette déclaration certifie la conformité avec les directives indiquées mais n'implique aucune garantie des propriétés. Les instructions de sécurité de la documentation accompagnant le produit doivent être suivies.

ISO 9001:2000 Zertifizierung / ISO 9001:2000 Certification

ACR Electronics Europe GmbH hat ein Qualitätsmanagement System nach ISO 9001:2000 implementiert, und ist seit Juli 2003 ISO-zertifiziert.

ACR Electronics Europe GmbH maintains a Quality Management System according to ISO 9001:2000, and received ISO certification in July 2003.



EG - Konformitätserklärung EC - Declaration of Conformity

Diese Konformitätserklärung bestätigt, dass das unten benannte Zubehör gleich oder besser dem im untenstehenden Zertifikat ausgewiesenen Zubehör ist.

This declaration of conformity certifies that the mentioned accessory is equal or better to the equipment stated in the beyond Certificate.

Produktbezeichnung: Product Name / Nom du produit	X-Pack DS (Inland AIS)
OEM Name: Trade Name / Marque Déposée	Nauticast™ Inland AIS
Zertifikate der benannten Stelle: Certificates from the notified Body / Certificats des Organismes Notifiés	EC Type Examination (Module B) Certificate: BSH/6412/4320296/06 EC Quality System (Module D) Certificate: BSH/4613/05101/0555/07 Issued by: Bundesamt für Seeschifffahrt und Hydrographie (BSH), Notified Body No. 0735 Bernhard-Nocht-Str. 78, 20359 Hamburg, Germany Inland AIS Type Approval Certificate No: R - 4 - 203 Issued by: Fachstelle der WSV für Verkehrstechniken Weinbergstraße 11-13, 56070 Koblenz, Germany
Spezifizierte Standards: Specified Standard(s) / Standard(s) Spécifié(s)	IMO MSC.74(69) Annex 3 ITU-R M.1371-3 (Class A) IALA Technical Clarifications of Rec. ITU-R M.1371-1 (Ed. 1.3) ITU-R M.825-3 ITU-R M1084-3 IEC 61993-2 (2001) IEC 61162-1 (2000), -2 (1998) IEC 60945 (1996) IEC 61108-1 (1996) Technical Specification for Vessel Tracking and Tracing Systems for Inland Waterways (Ed. 1.01 dated 10.10.2007) Test Standard for Inland AIS,(Edition 1.0 dated 31.5.2007)
Zubehörtyp: Type of Accessory	VHF Antenna Comrod AV-7
ACR Part Number:	2621
Dokumentnummer: Document number / Num. du document	2008-10
Hersteller: Manufacturer / Fabricant	ACR Electronics Inc., 5757 Ravenswood Road, Fort Lauderdale, Florida, 33312 USA
Anschrift EU-Vertretung: Address EU-Representative / Adresse du Représentant pour l'UE	ACR Electronics Europe GmbH Handelskai 388 / Top 632 A-1020 Vienna, Austria
Ort, Datum: place, date / Lieu,Date	Vienna, 2008-12-05
Unterschrift: Signature / Signature	 Andreas Lesch Managing Director

Diese Erklärung bescheinigt die Übereinstimmung mit den genannten Richtlinien, ist jedoch keine Zusicherung von Eigenschaften. Die Sicherheitshinweise der mitgelieferten Produktdokumentation sind zu beachten.
This declaration certifies the compliance with the indicated directives but implies no warranty of properties. The safety instructions of the accompanying product documentation shall be observed.
Cette déclaration certifie la conformité avec les directives indiquées mais n'implique aucune garantie des propriétés. Les instructions de sécurité de la documentation accompagnant le produit doivent être suivies.

ISO 9001:2000 Zertifizierung / ISO 9001:2000 Certification
ACR Electronics Europe GmbH hat ein Qualitätsmanagement System nach ISO 9001:2000 implementiert, und ist seit Juli 2003 ISO-zertifiziert.
ACR Electronics Europe GmbH maintains a Quality Management System according to ISO 9001:2000, and received ISO certification in July 2003.



EG - Konformitätserklärung EC - Declaration of Conformity

Diese Konformitätserklärung bestätigt, dass das unten benannte Zubehör gleich oder besser dem im untenstehenden Zertifikat ausgewiesenen Zubehör ist.

This declaration of conformity certifies that the mentioned accessory is equal or better to the equipment stated in the beyond Certificate.

Produktbezeichnung: Product Name / Nom du produit	X-Pack DS (Inland AIS)
OEM Name: Trade Name / Marque Déposée	Nauticast™ Inland AIS
Zertifikate der benannten Stelle: Certificates from the notified Body / Certificats des Organismes Notifiés	EC Type Examination (Module B) Certificate: BSH/6412/4320296/06 EC Quality System (Module D) Certificate: BSH/4613/05101/0555/07 Issued by: Bundesamt für Seeschifffahrt und Hydrographie (BSH), Notified Body No. 0735 Bernhard-Nocht-Str. 78, 20359 Hamburg, Germany Inland AIS Type Approval Certificate No: R - 4 - 203 Issued by: Fachstelle der WSV für Verkehrstechniken Weinbergstraße 11-13, 56070 Koblenz, Germany
Spezifizierte Standards: Specified Standard(s) / Standard(s) Spécifié(s)	IMO MSC.74(69) Annex 3 ITU-R M.1371-3 (Class A) IALA Technical Clarifications of Rec. ITU-R M.1371-1 (Ed. 1.3) ITU-R M.825-3 ITU-R M1084-3 IEC 61993-2 (2001) IEC 61162-1 (2000), -2 (1998) IEC 60945 (1996) IEC 61108-1 (1996) Technical Specification for Vessel Tracking and Tracing Systems for Inland Waterways (Ed. 1.01 dated 10.10.2007) Test Standard for Inland AIS,(Edition 1.0 dated 31.5.2007)
Zubehörtyp: Type of Accessory	GPS Antenna
ACR Part Number:	GPS Antenna AIS-A W/5M Coax 2639
Dokumentnummer: Document number / Num. du document	2008-11
Hersteller: Manufacturer / Fabricant	ACR Electronics Inc., 5757 Ravenswood Road, Fort Lauderdale, Florida, 33312 USA
Anschrift EU-Vertretung: Address EU-Representative / Adresse du Représentant pour l'UE	ACR Electronics Europe GmbH Handelskai 388 / Top 632 A-1020 Vienna, Austria
Ort, Datum: place, date / Lieu,Date	Vienna, 2008-12-05
Unterschrift: Signature / Signature	 Andreas Lesch Managing Director

Diese Erklärung bescheinigt die Übereinstimmung mit den genannten Richtlinien, ist jedoch keine Zusicherung von Eigenschaften. Die Sicherheitshinweise der mitgelieferten Produktdokumentation sind zu beachten.

This declaration certifies the compliance with the indicated directives but implies no warranty of properties. The safety instructions of the accompanying product documentation shall be observed.

Cette déclaration certifie la conformité avec les directives indiquées mais n'implique aucune garantie des propriétés. Les instructions de sécurité de la documentation accompagnant le produit doivent être suivies.

ISO 9001:2000 Zertifizierung / ISO 9001:2000 Certification

ACR Electronics Europe GmbH hat ein Qualitätsmanagement System nach ISO 9001:2000 implementiert, und ist seit Juli 2003 ISO-zertifiziert.

ACR Electronics Europe GmbH maintains a Quality Management System according to ISO 9001:2000, and received ISO certification in July 2003.

Quick Replacement Guide Inland AIS



1. Prepare the following tools:

Screwdrivers, spanners,

User Password: [your personal password]

(Should be written to you user manual - Appendix 7.3.
The factory default password is on the display foil)

2. Read out your Transponder configuration:

This form guides you to save the most important settings (bold marked) prior to an AIS replacement. Voyage related settings may be stored here as well, but we assume you know how to key them in.

Steps to do this:

Press Menu

Press 2 2.AIS Status

Press 2 2.Own Ship Data

Write down your current configuration settings:

IMO No. :		MMSI:	
ShipName :		ATIS:	
ShipType :		Cargo:	
Length :		Beam :	
Cargo :			
Draught :			

(Press Enter ↵ to reach 2.screen view for)

ENI:			
Blue Sign:			
Convoy:			
Load:		Hazard:	
Persons on Board:			
Crew:		Support:	
Int'l:		Passengers:	

Reference Points:

Press Menu

Press 4 4.Ship Settings

Type in [UserPassword] **Press** Enter ↵

Write down the current configuration settings here:

RefPtExt:	A	B	C	D
RefPtInt:	A	B	C	D

Blue Sign:

Press Menu

Press 5 5.Transponder Configuration

Type in [UserPassword] **Press** Enter ↵

Press 7. 7.Inland AIS Configuration

Speed:	<LOW*> or <High*>
Course :	<LOW*> or <High*>
Heading:	<LOW*> or <High*>
Blue Sign:	[not available] or [Used]

*(most time LOW)

Sensor Settings:

When you have connected a external GPS or Compass to your AIS:

Press Menu

Press 5 5.Transponder Configuration

Type in [UserPassword] **Press** Enter ↵

Press 5 5.Sensor Settings

Type in [ServicePassword] **Press** Enter ↵

Write down the current configuration settings here:

BaudRate Sensor1:	
BaudRate Sensor2:	
BaudRate Sensor3:	

Press M8 Back

3. Detach the device

3.1. Bracket Mounting

3.2. Frame Mounting

4. Disconnect cables

4.1. AIS-Cable to unscrew

4.2. VHF/GPS Cable to unscrew

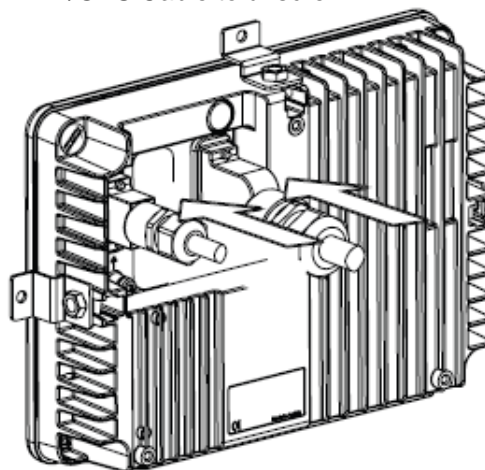

5. Unpack the new Transponder

New factory default password is on its display protection foil

6. Connect cables

6.1. AIS-Cable to screw on

6.2. VHF/GPS Cable to screw on

7. Mount the replacement unit

7.1. Bracket Mounting

7.2. Frame Mounting

8. Type in the configuration settings from above:

Following steps to type in the Configuration

MMSI/IMO – Number:

The AIS will prompt 'ENTER MMSI NUMBER'

Press M5 OK

Type in MMSI and IMO number

Press M5 Save (AIS will Restart)

Quick Replacement Guide

Inland AIS



Service Configuration:

Press Menu

Press 6. 6.Service Configuration

Type in [ServicePassword] **Press** Enter ↵
(Default Factory Password)

Press 4. 4.Change DAC / ENI

DAC is 200 for Europe, ENI - type in the number from your filled in tabel:

Ship Settings:

Press Menu

Press 4 4.Ship Settings

Type in [UserPassword] **Press** Enter ↵
(Default Factory Password)

Type in the configuration data from your list:

ATIS:

ShipName:

Length: Beam:

(complete length and beam of your convoy IN METER)

RefPtExt: AxxCxx

(B and D are calculated by the AIS)

RefPtInt: AxxCxx

(B and D are calculated by the AIS)

Length: Beam:

(complete length and beam of your convoy IN DECI-METER 1m=10dm)

Blue Sign:

Press Menu

Press 5 5.Transponder Configuration

Type in [UserPassword] **Press** Enter ↵
(Default Factory Password)

Press 7. 7.Inland AIS Configuration

Configure the BlueSign as stored in the settings table above

Sensor Settings:

Press Menu

Press 5 5.Transponder Configuration

Type in [UserPassword] **Press** Enter ↵
(Default Factory Password is on the display foil)

Press 5 5.Sensor Settings

Type in [ServicePassword] **Press** Enter ↵

Type in the configuration data from your list: (see page 1)

BaudRate Sensor1:

BaudRate Sensor2:

BaudRate Sensor3:

Press M5 Save

9. Check the functionality

Press Menu

Press 2 2.AIS Status

Press 2 2.Own Ship Data

You should see your Own Ship Data with correct values for LAT, LON, SOG, COG, Time

9.1. Change your Service and User Password

Press Menu

Press 6 6.ServiceConfiguration

Type in [ServicePassword] **Press** Enter ↵ (Default Factory Password)

Press 2 2.UserPasswordSettings

Press 1 1.Change User Password

Type in [new password]

Repeat [new password]

Press M5 Save

Save your personal password by writing it down in the User Manual Appendix 7.3