

DIGITAL CAMERA

FinePix S602 Zoom**Getting Ready****Basic
Photography****Advanced
Features
Photography****Advanced
Features
Playback****Settings****Connection****OWNER'S MANUAL**

This manual will show you how to use your FUJIFILM DIGITAL CAMERA FinePix S602 ZOOM correctly. Please follow the instructions carefully.



Warning

To prevent fire or shock hazard, do not expose the unit to rain or moisture.

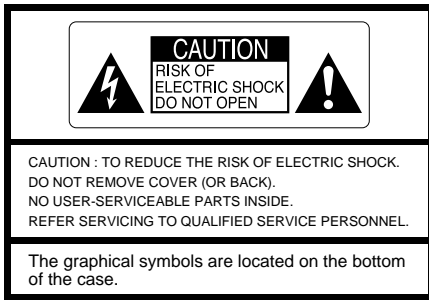

This symbol is intended to alert the user to the presence of uninsulated “dangerous voltage” within the product’s enclosure that may be of sufficient magnitude to constitute a risk of electric shock to persons.



This symbol is intended to alert the user to the presence of important operating and maintenance (servicing) instructions in the literature accompanying the appliance.

For customers in the U.S.A.

FCC Statement

This device complies with part 15 of the FCC Rules. Operation is subject to the following two conditions: (1) This device may not cause harmful interference, and (2) this device must accept any interference received, including interference that may cause undesired operation.

CAUTION

This equipment has been tested and found to comply with the limits for a Class B digital device, pursuant to Part 15 of the FCC Rules. These limits are designed to provide reasonable protection against harmful interference in a residential installation. This equipment generates, uses, and can radiate radio frequency energy and, if not installed and used in accordance with the instructions, may cause harmful interference to radio communications. However, there is no guarantee that interference will not occur in a particular installation. If this equipment does cause harmful interference to radio or television reception, which can be determined by turning the equipment off and on, the user is encouraged to try to correct the interference by one or more of the following measures:

- Reorient or relocate the receiving antenna.
- Increase the separation between the equipment and receiver.
- Connect the equipment into an outlet on a circuit different from that to which the receiver is connected.
- Consult the dealer or an experienced radio/TV technician for help.

You are cautioned that any changes or modifications not expressly approved in this manual could void the user’s authority to operate the equipment.

Notes on the Grant:

To comply with Part 15 of the FCC rules, this product must be used with a Fujifilm-specified ferrite-core A/V cable, USB cable and DC supply cord.

For customers in Canada

CAUTION

This Class B digital apparatus complies with Canadian ICES-003.

Please read the Safety Notes (➔P.90) and make sure you understand them before using the camera.

EC Declaration of Conformity

We
Name : Fuji Photo Film (Europe) G.m.b.H.
Address : Heesenstrasse 31
40549 Dusseldorf, Germany

declare that the product
Product Name : FUJIFILM DIGITAL CAMERA FinePix S602 ZOOM
Manufacture's Name : Fuji Photo Film Co., Ltd.
Manufacture's Address : 26-30, Nishiazabu 2-chome, Minato-ku,
Tokyo 106-8620, Japan

is in conformity with the following Standards
Safety : EN60065
EMC : EN55022 : 1998 Classe B
EN55024 : 1998
EN61000-3-2 : 1995 + A1:1998 + A2:1998

following the provision of the EMC Directive (89/336/EEC, 92/31/EEC and 93/68/EEC) and Low Voltage Directive (73/23/EEC).



Dusseldorf, Germany	May 1, 2002	
Place	Date	Signature/Managing Director



Bij dit produkt zijn batterijen geleverd. Wanneer deze leeg zijn, moet u ze niet weggooien maar inleveren als KCA

Contents

Warning	2	Camera Features and Accessories	7
EC Declaration of Conformity	3	Nomenclature	8
Preface	6		

Getting Ready

ATTACHING THE LENS CAP AND CAMERA STRAP	10
LOADING THE BATTERIES	12
Compatible Batteries	12
LOADING THE MEDIA	14
SmartMedia™ (optional)	14
Microdrive (optional: supplied by another manufacturers)	14
SWITCHING ON AND OFF • SETTING THE DATE AND TIME	16
Selecting the Language	17
Number of Available Shots	17
■ Standard Number of Shots for the Media	17

Basic Photography

BASIC OPERATION GUIDE	18
ACTUALLY TAKING PICTURES	22
TAKING PICTURES (AUTO MODE)	22
■ Indicator Lamp Display	24
USING AF/AE LOCK	25
DIGITAL ZOOM	26
BEST FRAMING	26
VIEWING YOUR IMAGES (PLAYBACK)	27
Fast-forwarding Through Your Images/Multi-frame Playback	27
Single-frame Playback/Playback Zoom/Panning/Trimming	28
Erasing Images (Erase Frame)	29

Advanced Features Photography

FOCUSING (DISTANCE)	30
EXPOSURE (APERTURE AND SHUTTER SPEED)	31
TAKING PICTURES — SELECTING THE CAMERA SETTINGS	32
■ List of Functions Available in Each Mode	33
■ List of Menu Options Available in Each Mode	33

PHOTOGRAPHY MODE

AUTO AUTO	34
SP SCENE POSITION	34
👤Portrait/🌄Landscape/🏃Sports/🌃Night Scene/📷Monochrome	
P PROGRAMMED AUTO	35
Program Shift	35
S SHUTTER-PRIORITY AUTO	36
A APERTURE-PRIORITY AUTO	37
M MANUAL	38
🎥 MOVIE (VIDEO)	39
■ Standard Available Shooting Times for Different Media	39
FLASH PHOTOGRAPHY	41
⚡ Auto Flash	42
👁 Red-Eye Reduction	42
⚡ Forced Flash	42
⚡ Slow Synchro	42
👁 Red-Eye Reduction + Slow Synchro	42
CONTINUOUS SHOOTING	43
📷 Top 5-frame Continuous Shooting	44
📷 Auto Bracketing	44
📷 Final 5-frame Continuous Shooting	44
📷 Long-period Continuous Shooting with 1280 · 960-pixel mode	45
☑ EXPOSURE COMPENSATION	46
AE-L USING AE LOCK	47
📷 MACRO (CLOSE-UP) PHOTOGRAPHY	47

Advanced Features Photography

SETTING THE MANUAL FOCUS	48
One-touch AF Function	48
[] Focus Check Function	48
PHOTOGRAPHY MENU	49
PHOTOGRAPHY MENU OPERATION	49
⌚ SELF-TIMER PHOTOGRAPHY	50
[ISO] SETTING THE ISO SENSITIVITY	51
High-sensitivity Photography (ISO 800/1600)	51
[WB] SETTING THE WHITE BALANCE	52
Custom White Balance	52
[O] PHOTOMETRY	54
[] AUTO BRACKETING	54
[] SHARPNESS	55
[] MULTI-EXPOSURE	55
[] FLASH BRIGHTNESS ADJUSTMENT	56
[] USING AN EXTERNAL FLASH	56
External Flash Settings	57
When the White Balance is Incorrect	57
[] VOICE MEMO	58

Advanced Features Playback

PLAYBACK INFORMATION	59
PLAYING BACK MOVIES	60
■ Playing Back Movies	60
PLAYING BACK VOICE MEMOS	61
■ Playing Back Voice Memos	61
PLAYBACK MENU	62
[] ERASING SINGLE FRAME • ALL FRAMES/FORMATTING	62
HOW TO SPECIFY PRINT OPTIONS (DPOF)	64
[] VOICE MEMO (RECORDING)	66

Settings

SET-UP	68
■ SET-UP Menu Options	68
SET USING THE SET-UP SCREEN	68
[] NUMBER OF RECORDED PIXELS	69
[] NUMBER OF RECORDED PIXELS	69
DISPLAYING PHOTOGRAPHED IMAGES	70
Preview Zoom/Selecting Images to Record	70
AF MODE	71
AF AREA	71
SET ADAPTER RING	72
AUTO POWER OFF SETTING	73

Connection

CONNECTING TO A TV/USING THE AC POWER ADAPTER (OPTIONAL)	74
CONNECTING TO A COMPUTER	75
The first time you connect the camera to your computer/ DSC (Mass storage device) Mode/PC-CAM (camera) Mode	75
CONNECTING AT DSC MODE	76
CONNECTING AT PC CAMERA MODE	77
DISCONNECTING FROM THE PC (Important — always use this procedure.)	78

System Expansion Options	79	Notes on the Media	
Accessories Guide	80	(SmartMedia™ and Microdrives)	83
Notes on Using Your Camera Correctly	81	Warning Displays	84
Notes on the Power Supply	82	Troubleshooting	86
Applicable Batteries	82	Specifications	88
Notes on the Batteries	82	Explanation of Terms	89
Notes on Using the AC Power Adapter	82	Safety Notes	90

1

2

3

4

5

6

Preface

■ Test Shots Prior to Photography

For particularly important photographs (such as weddings and overseas trips), always take a test photograph and view the image to make sure that the camera is functioning normally.

- Fuji Photo Film Co., Ltd. cannot accept liability for any incidental losses (such as the costs of photography or the loss of income from photography) incurred as a result of faults with this product.

■ Notes on Copyright

Images recorded using your digital camera system cannot be used in ways that infringe copyright laws without the consent of the owner, unless intended only for personal use. Note that some restrictions apply to the photographing of stage performances, entertainments and exhibits, even when intended purely for personal use. Users are also asked to note that the transfer of memory cards (SmartMedia or Microdrive) containing images or data protected under copyright laws is only permissible within the restrictions imposed by those copyright laws.

■ Liquid Crystal

If the LCD monitor or viewfinder (EVF) is damaged, take particular care with the liquid crystal in the monitor or finder. If any of the following situations arise, take the urgent action indicated.

- If liquid crystal comes in contact with your skin
Wipe the area with a cloth and then wash thoroughly with soap and running water.
- If liquid crystal gets into your eye
Flush the affected eye with clean water for at least 15 minutes and then seek medical assistance.
- If liquid crystal is swallowed
Flush your mouth thoroughly with water. Drink large quantities of water and induce vomiting. Then seek medical assistance.

■ Notes on Electrical Interference

If the camera is to be used in hospitals or aircrafts, please note that this camera may cause interference to other equipment in the hospital or aircraft. For details, please check with the applicable regulations.

■ Handling Your Digital Camera

This camera contains precision electronic components. To ensure that images are recorded correctly, do not subject the camera to impact or shock while an image is being recorded.

■ Trademark Information

- iMac and Macintosh are registered trademarks of Apple Computer, Inc.
- Microsoft, Windows, and the Windows logo are trademarks, or registered trademarks of Microsoft Corporation in the United States and/or other countries. Windows is an abbreviated term referring to the Microsoft Windows Operating System.
- * The "Designed for Microsoft Windows XP" logo refers to the camera and the driver only.
- SmartMedia is a trademark of Toshiba Corporation.
- CompactFlash is trademark of Sandisk Corporation of the U.S.
- Microdrive is a trademark of the International Business Machines Corporation of the U.S.
- Other company or product names are trademarks or registered trademarks of the respective companies.

■ Explanation of Color Television System

NTSC: National Television System Committee, color television telecasting specifications adopted mainly in the U.S.A., Canada and Japan.

PAL: Phase Alternation by Line, a color television system adopted mainly by European countries and China.

■ Exif Print (Exif ver. 2.2)

Exif Print Format is a newly revised digital camera file format that contains a variety of shooting information for optimal printing.

Camera Features and Accessories

Features

- 3.1 million effective pixels
- 1/1.7-inch Super CCD provides high quality images with 2832 × 2128 (6.03 million) recorded pixels
- Powerful Super EBC Fujinon 6× optical zoom lens (aspherical lens) for superb optical performances
- Maximum 4.4× seamless digital zoom
- Wide range of light sensitivity settings from ISO 160, 200, 400 up to ultra-high settings with ISO 800* and 1600*
 - * In 1280 × 960 pixels mode only
- "Motion Photo" VGA-sized movie with monaural sound (640 × 480 pixels at 30 frames/sec.)
- Dual media slots for SmartMedia and Microdrive
- Fast-acting dual-method focusing system that combines an external AF sensor (passive phase-difference AF sensor) and CCD-AF
- Quick, responsive operation with 3 second start-up and only 1 Second between shots
- Auto focus with macro function (manual focusing function also available)
- Super Macro function for close-up shots as near as 1cm (0.4 inch) to the subject
- Three type high-speed continuous shooting mode
 - Top 5-frame continuous shooting (5 frames/sec.)
 - Final 5-frame continuous shooting (5 frames/sec. within 5 seconds/25 shots)
 - Long-period continuous shooting with 1280 × 960 pixels mode (1.8 frames/sec. up to 40 frames)
- AF AREA function lets you choose from 49 focusing points in the view finder image
- A wide range of exposure modes (including manual exposure) let you adjust your photography settings as you like
- A ultra-wide range of shutter speed from 1/10,000 sec to long exposures up to 15 sec in Manual mode
- 0.44" 180,000-pixel electric viewfinder with diopter adjustment mechanism
- 1.8" 110,000-pixel LCD monitor (low-temperature polysilicon TFT) with 100% coverage
- Support to external flash units
- Convenient preview function for checking your shots
- Immediate exposure checking after shooting using histogram indication function
- Playback zoom function (max. 18×)
- Multiple exposure and monochrome photography function provides a wider range of photography options
- INFO button allows you to view your photography settings at a touch whenever the need arises
- Easy high-speed data transfer via the USB connection
- Conforms to "Design for Camera File system" standard and Exif ver 2.2 for digital cameras
 - * "Design for Camera File system" standard and Exif format are formulated by the Japanese Electronic and Information Association (JEITA)

Accessories

● SmartMedia (16MB, 3.3V) (1)

Supplied with:

- Anti-static case (1)
- Index label (1)

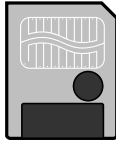

● AA-size alkaline batteries (4)

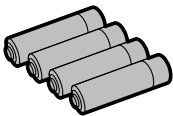

● Shoulder Strap (1)



● Protective cover (2)



● Metal strap clip (2)



● Clip attaching tool (1)



● Lens cap (1)

● Lens cap holder (1)



● A/V Cable (approx. 1.5 m (4.9 ft.), mini-plug (2.5 mm dia.) to pin-plug cable × 2) (1)

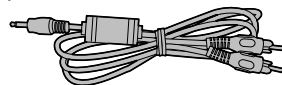

● USB Interface Set (1)

- CD-ROM: Software for FinePix EX (1)
- Special USB cable with Noise Suppression core (1)
- Software Quick Start Guide (1)

● Owner's Manual (this manual) (1)

Nomenclature

* Refer to the pages in parentheses for information on using the camera features.

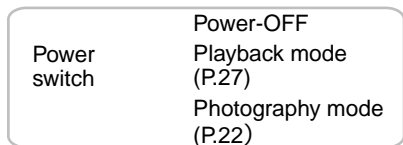

Hot shoe (P.56)

Focusing ring (P.20,48)



Command dial (P.19)

Self-timer lamp (P.50)

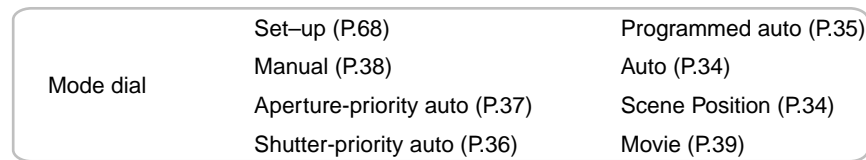

Flash control sensor

Flash (P.41)

AF sensor

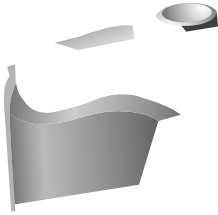

Flash pop-up button (P.18,41)

Microphone

INFO (information check) button
(P.20,49,59)

Strap mount (P.10)

(USB) socket (P.76,77)

Speaker

A/V OUT (Audio/visual output)
socket (P.74)



Terminal cover

(One-touch AF) button
(P.20,48)

DC IN 5V (power input) socket
(P.74)

Terminal cover

Focus mode selector switch (P.20,48)

SHIFT button (P.21)

Lens

Macro (close-up photography)
button (P.47)

1 Getting Ready

ATTACHING THE LENS CAP AND CAMERA STRAP

When attaching the strap to the camera, attach the metal strap clip to the camera before threading the strap through the clip. This description explains how to attach the strap using the clip attaching tool provided to make attaching the metal strap clip easier. (Numbers **1** to **8** refer to the illustrations.)

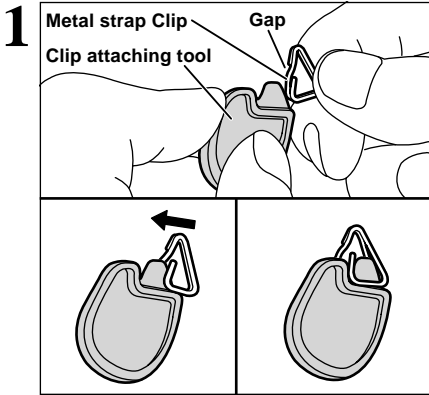

Checking that the metal strap clip is facing the right way, slide the clip fully into the clip attaching tool and open up the gap in the strap clip.

Keep the clip attaching tool in a safe place as you will also need it for removing the metal strap clip from the camera.

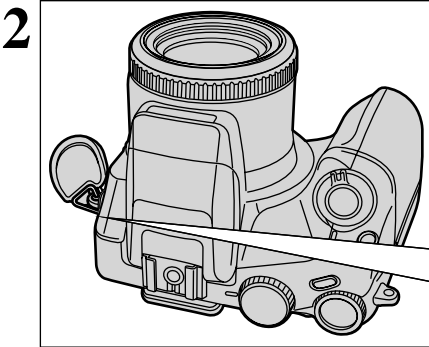

Hook the open metal strap clip through the strap mount on the camera. Once the clip is securely hooked through the strap mount, hold the clip in place as you remove the clip attaching tool.

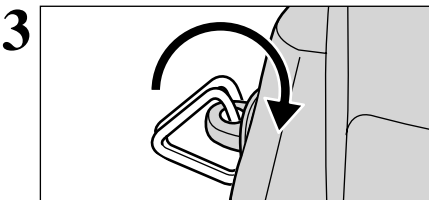

Turn the metal strap clip around once until it clicks closed and is fully threaded onto the strap mount.

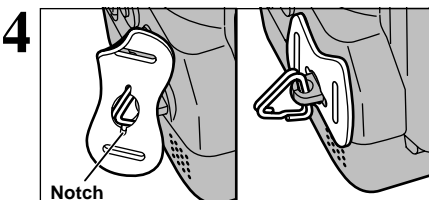

Face the black side of the cover towards the camera and attach the strap by threading the strap through the strap clip, starting from the notched side.

Repeat steps **1** to **4** to attach the other end of the strap.

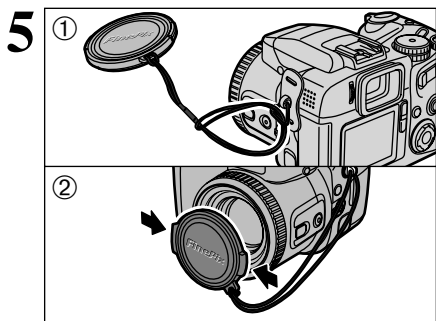

- ① Attach the lens cap cord by threading it through the metal strap clip near the terminal cover.
- ② Attach the lens cap by pressing in on each side of the cap.

⚠ The lens cap cord should be attached to the camera to avoid losing the lens cap.

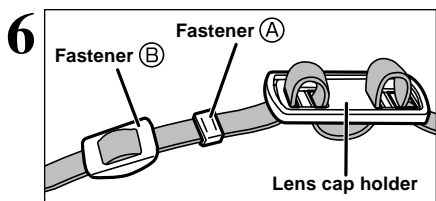

Remove fasteners **A** and **B** from only one side of the shoulder strap. Then pass the shoulder strap through the lens cap holder and then back through fasteners **A** and **B**.

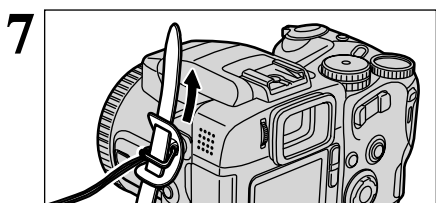

Thread the strap through the protective cover and metal strap clip.

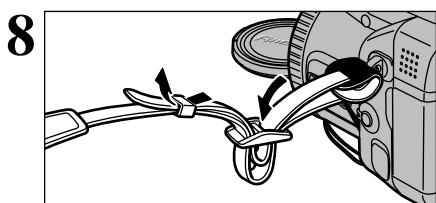

Thread the strap through the buckle and retainer. Repeat steps **7** to **8** to attach the other end of the strap.

◆ Using the Lens Cap Holder ◆

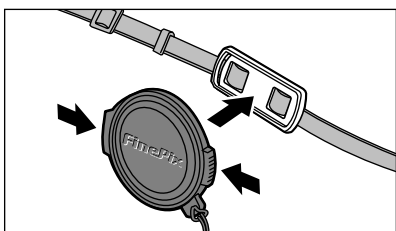

To ensure that the lens cap does not appear in your shot when you take a picture, attach it to the lens cap holder.

LOADING THE BATTERIES

Compatible Batteries

AA-size alkaline batteries (4) or AA-size Ni-MH (nickel-metal hydride) batteries (4, sold separately)

About the Batteries

- Never use a battery when the outer casing is split or peeling as this could result in a short-circuit and cause major problems due to battery fluid leakage or overheating.
- Do not use lithium, manganese or nickel-cadmium (Ni-Cd) batteries.
- Do not use batteries of different types or brands together and do not use new batteries together with used batteries.
- The useful life of alkaline batteries varies depending on the brand. The life of some batteries may be considerably shorter than the batteries supplied with the camera. Due to the nature of alkaline batteries, the time for which they can be used is shorter in cold locations (+10°C (+50°F) or below).
- Soiling such as fingerprints or grease on the poles of batteries can significantly reduce the number of shots that can be taken.
- See P.82 for other precautions concerning the use of batteries.

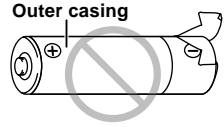

When Using AA-size Ni-MH Batteries

To charge Ni-MH batteries, the optional charger (➔ P.80) is required.

- Always use the specified FUJIFILM batteries. Attempting to recharge other types of battery (manganese, alkaline or lithium batteries) could cause the batteries to burst or leak fluid, causing a fire or injury or damage to surroundings.
- Soiling on the poles of Ni-MH batteries may prevent successful charging. It is recommended that you make a practice of wiping the battery poles and charger terminals with a clean dry cloth before charging. (In particular, the first time you charge the batteries, you should clean the poles and terminals and then load the batteries into the charger and remove them again several times before you begin charging.)
- Do not use new batteries together with used batteries.
- Always charge batteries before using them. Newly purchased batteries or batteries that have not been used for a long period may not contain sufficient charge (so that the battery low warning appears immediately or the available shots/time displayed for the battery is low). This is a characteristic of the batteries and does not indicate a fault. Once the batteries have been charged and used 3 or 4 times, it will be possible to charge them fully and they will supply power for longer.
- If you charge Ni-MH batteries before they are fully depleted, this results in the “memory effect”, which causes the battery low warning to appear sooner. To restore the batteries to their normal condition, use up all the charge in the batteries before recharging them.
 - * Memory effect: A phenomenon whereby the battery capacity appears to be lower than the nominal amount.

1

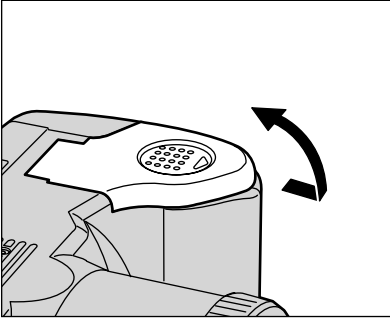

Slide the battery cover out and lift it open.

Never open the battery cover while the camera is switched on as this could damage the media or the image files.

1

Getting Ready

2

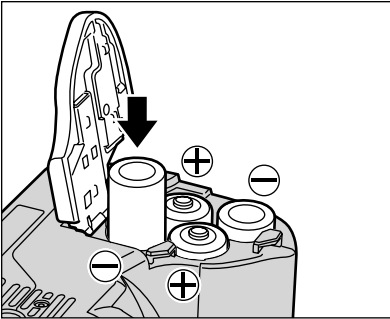

Insert the batteries correctly as indicated by the polarity icons.

3

① Close the battery cover.
② While pressing on the battery cover to push the batteries down, ③ slide the cover closed.

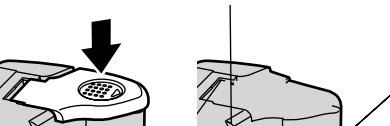

LOADING THE MEDIA

You can use either SmartMedia or Microdrive as recording media in the FinePix S602 ZOOM.

- If you load a SmartMedia and a Microdrive at the same time, images will be recorded onto the media selected as the "Primary media" (→ "Settings" P.68).
- Data cannot be copied between the two media types on the FinePix S602 ZOOM.

SmartMedia™ (optional)

Always use 3.3-volt SmartMedia.

- MG-4S (4 MB)
- MG-8S (8 MB)
- MG-16S (16 MB)
- MG-16SW (16 MB, ID)
- MG-32S (32 MB)
- MG-32SW (32 MB, ID)
- MG-64SW (64 MB, ID)
- MG-128SW (128 MB, ID)

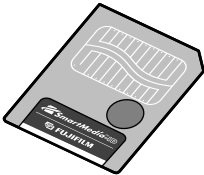

- ⚠ Images cannot be recorded or erased if a write-protect sticker is affixed to the SmartMedia.
- ⚠ Operation of this camera is only guaranteed when it is used with FUJIFILM SmartMedia.
- ⚠ Some 3.3V SmartMedia are labeled as "3V" or "ID" cards.
- ⚠ See P.83 for more information on using SmartMedia.

Microdrive (optional: supplied by another manufacturers)

- Microdrive 340MB
- Microdrive 1GB



- ⚠ Microdrives are actually very small and light hard disks. Because they are a spinning storage medium, they are less resistant to vibration and impacts than SmartMedia. If you are using a Microdrive, take great care not to expose the camera to vibration or impacts (particularly during recording or playback).
- ⚠ The use of Ni-MH (nickel-metal hydride) batteries is recommended when using as Microdrive.
- ⚠ See P.83 for more information on using Microdrive.

1

Set the Power switch to "OFF", check that the indicator lamp is off and then open the slot cover.

- ⚠ If you open the slot cover while the camera is still switched on, the camera is switched off as a safety measure.

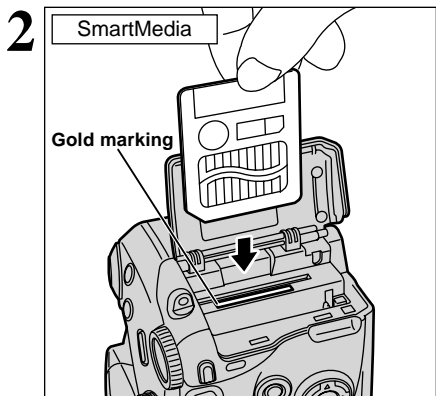

Push the SmartMedia firmly all the way into the SmartMedia slot.

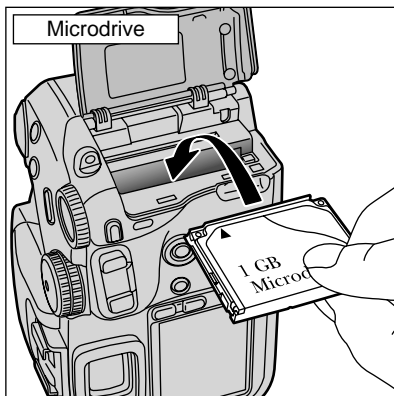

Push the Microdrive firmly all the way into the Microdrive slot.

- ⚠ Insert only the appropriate media types into the Microdrive and SmartMedia slots. Inserting the incorrect media will damage the camera and/or media.
- ⚠ If the media is oriented incorrectly, it will not go all the way into the slot. Do not apply excessive force when inserting a SmartMedia or Microdrive.
- ⚠ If the SmartMedia is not fully inserted into the slot, "CARD ERROR" is displayed.

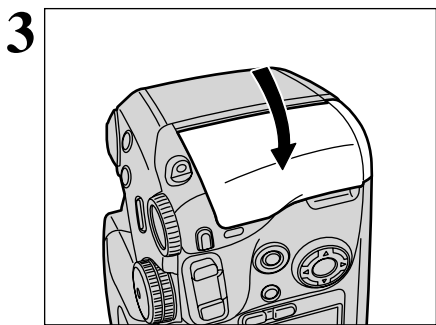

Close the slot cover

◆ Replacing a SmartMedia ◆

If you open the slot cover and push down lightly on the SmartMedia, it will pop out slightly and can then be easily removed.

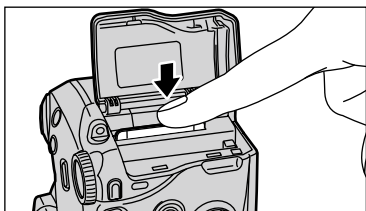

◆ Replacing a Microdrive ◆

Open the slot cover, press the Microdrive eject button and remove the Microdrive.

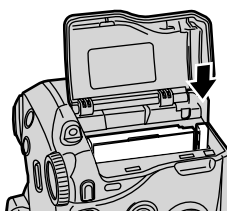

SWITCHING ON AND OFF • SETTING THE DATE AND TIME

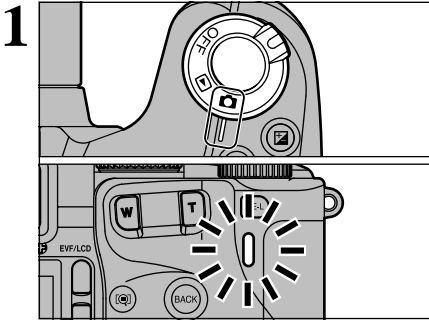

To switch the camera on, set the Power switch to “**ON**” or “**▶**”. When you switch the camera on, the indicator lamp lights green.
To switch the camera off, set the Power switch to “**OFF**”.

When you select “**ON**” mode, the lens moves out. Take care not to obstruct the lens as it is a precision component. Obstructing the lens will cause a malfunction or fault and the “**(ZOOM ERROR)**” or “**(FOCUS ERROR)**” message will appear. Take care also not to get fingerprints on the camera lens as this will result in impaired image quality in your shots.

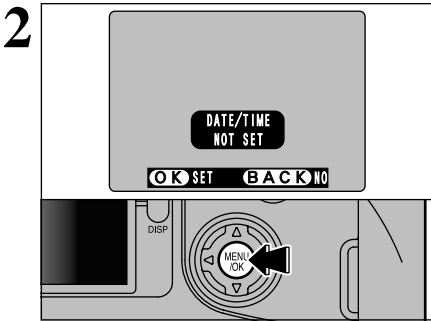

When you first switch the camera on, the date is cleared. Press the “**MENU/OK**” button to set the date and time.

- ⚡ To set the date and time later, press the “**BACK**” button.
- ⚡ If you do not set the date and time, this confirmation screen will appear each time you switch the camera on.

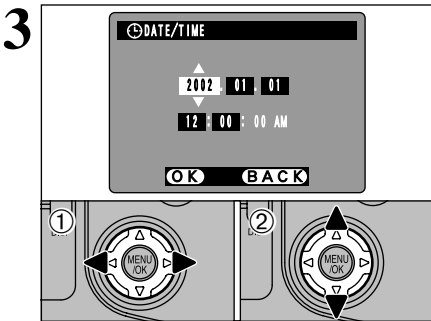

- ① Use “**◀**” and “**▶**” to select Year, Month, Day, Hour or Minute.
- ② Use “**▲**” and “**▼**” to correct the setting.

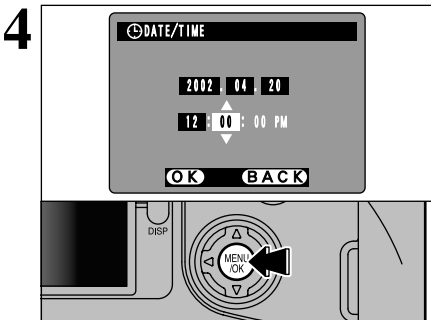

- ⚡ If you hold down “**▲**” or “**▼**”, the numbers change continuously.
- ⚡ When the time displayed passes “12:00:00”, the AM/PM setting automatically switches.







Press the “**MENU/OK**” button to switch to photography or playback mode.



- ⚡ To set the time precisely, press the “**MENU/OK**” button when the time is at zero seconds.
- ⚡ Once the AC power adapter has been connected or the batteries have been installed for an hour or more, the camera will retain the specified date and time for approximately 10 days without power (with the batteries removed and AC power adapter disconnected).

◆ Checking the Battery Level ◆

Switch the camera on and check that no battery level icon ( or ) is displayed. If no icon is displayed, the battery has sufficient remaining charge.

-  **Lit red** : The batteries are low on charge. Replace the batteries as they will run out shortly.
 -  **Blinking red**: The batteries have no remaining charge. The display will shortly go blank and the camera will stop working. Replace the batteries.
- ⚠ If the  icon starts flashing red while a movie is being shot, shooting automatically stops.
- ⚠ Do not reuse batteries that have no remaining charge ( blinking red) as this can result in faults such as the camera switching off without retracting the lens.

◆ Auto Power Off Function ◆

If the camera is not used in any way for approx. 30 seconds when the camera functions are enabled, this function temporarily switches features such as the LCD monitor off to reduce power consumption (⇒P.73). If the camera is then left unused for a further period (2 or 5 minutes), the Auto Power Off function automatically switches the camera off. To switch the camera back on, set the Power switch to “OFF” briefly and then back to “” or “”.

Selecting the Language

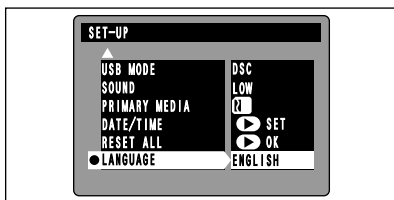

You can use the “SET-UP” screen on this camera to select “ENGLISH”, “FRANCAIS” or “DEUTSCH” as the “LANGUAGE” used for screen display (⇒P.68). The screens in this manual are shown in “ENGLISH”.

Number of Available Shots

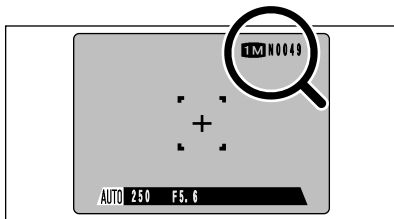

The number of available shots is displayed on the screen.

- ⚠ See P.69 for information on changing the number of recorded pixels/Quality (compression ratio) setting.
- ⚠ The factory default settings set at shipment are **11M** (Number of recorded pixels) and **N** (Quality: normal).

■ Standard Number of Shots for the Media

[Because the amount of data needed to record an image varies slightly depending on the type of subject, the number of available shots may not decrease after an image is recorded, or may decrease by 2 in some cases. Also, the difference between the standard number of shots and the actual number of available shots increases for media with a higher capacity.]

Number of recorded pixels	6M 2832 × 2128				3M 2048 × 1536		11M 1280 × 960		16M 640 × 480
	HIGH	FINE	NORMAL	BASIC	FINE	NORMAL	FINE	NORMAL	NORMAL
Quality Mode	Approx. 18MB	Approx. 2.4MB	Approx. 1.2MB	Approx. 460KB	Approx. 1.3MB	Approx. 590KB	Approx. 620KB	Approx. 320KB	Approx. 130KB
Image File Size	0	1	3	8	2	6	6	12	30
MG-4S (4MB)	0	3	6	17	6	13	12	25	61
MG-8S (8MB)	0	6	13	33	12	26	25	49	122
MG-16S/SW (16MB)	1	13	28	68	25	53	50	99	247
MG-32S/SW (32MB)	3	26	56	137	50	107	101	198	497
MG-64S/SW (64MB)	7	53	113	275	102	215	204	398	997
MG-128SW (128MB)	19	147	311	765	279	589	566	1119	2729
Microdrive 340MB	59	443	938	2190	842	1729	1642	3285	8213
Microdrive 1GB									

* Number of available shots for formatted media.

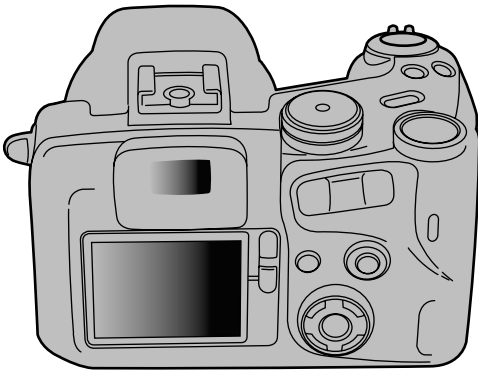

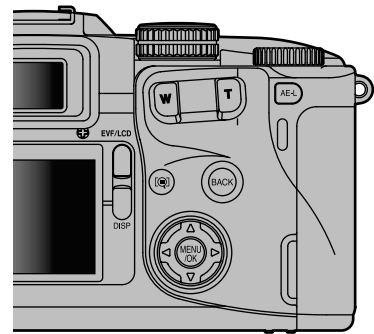
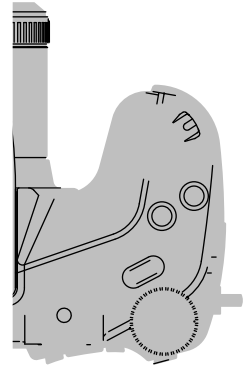

BASIC OPERATION GUIDE

●Diopter adjustment dial

Makes the image in the viewfinder easier to see. Set the dial to the position where the AF frame appears sharpest.

●Focus Check button

Pressing this button enlarges the central portion of the screen. Use this to focus the image precisely.

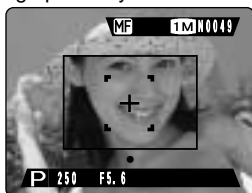

●AE-L button

The exposure remains locked while this button is pressed.

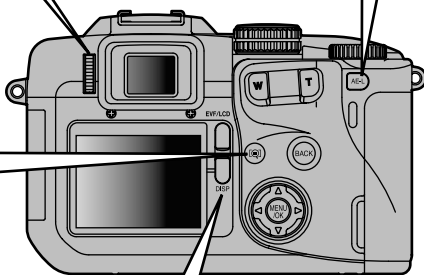

●DISP button

Switches the screen display.

Photography mode

Text displayed
↓
Framing guideline displayed
↓
No text displayed

Playback mode

Text displayed
↓
No text displayed
↓
Multi-frame playback

●Focusing ring

Adjusts the focus. This can only be used for manual focusing.

●INFO button

Photography information is displayed while this button is pressed.
Photography mode: Displays the current settings (ISO (sensitivity), sharpness, etc.)
Playback mode: Displays the information for the image currently displayed.

●SHIFT button

See following page.

●One-touch AF button

Uses the AF function to focus the image once. This can only be used for manual focusing.

●Focus mode selector switch

Switches between AF (auto focus) and MF (manual focus).

●Macro button

Use this for close-up photography. Pressing this button switches the modes as follows:

Macro → Super Macro → Macro off

Shooting range: Macro : 10 cm-80 cm (3.9 in.-2.6 ft.)

Super Macro: 1 cm-20 cm

Macro off : 50 cm (1.6 ft.) to infinity (wide-angle), 90 (3.0 ft.) cm to infinity (telephoto-angle)

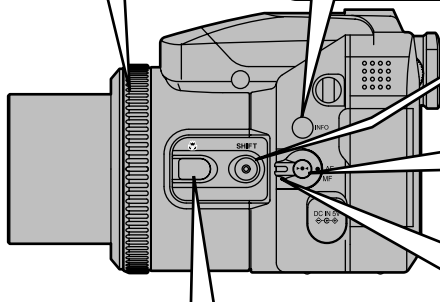

●SHIFT button

Holding down the “SHIFT” button for 1 second or longer displays the “SHIFT CONTROL” guide. By pressing one of the displayed button combinations, you can quickly and easily access the corresponding setting.

The functions you can access vary depending on the current mode. The example below shows the procedure for photography mode.

Hold down the “SHIFT” button for 1 second or longer

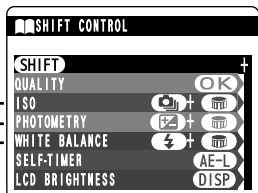

OK

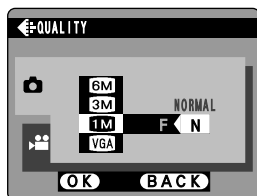

Number of recorded pixels

Holding down the “SHIFT” button and pressing the “MENU/OK” button displays the menu. Use the “▲▼◀▶” button to select a setting and the “MENU/OK” button to confirm the setting.

2

Basic Photography

AE-L

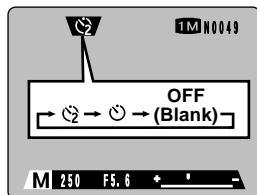

Self-timer

Hold down the “SHIFT” button and press the “AE-L” button to switch between 2 sec., 10 sec. and OFF as the self-timer setting.

DISP

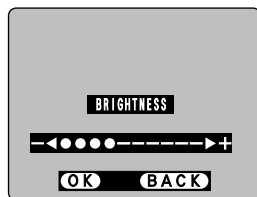

ISO Sensitivity, photometry and white balance

Holding down the “SHIFT” button and pressing a button changes the setting on the command dial. Release the button to confirm the setting.

Refer to the page listed in the table below for details of the respective settings.

Number of recorded pixels	P.69
Self-timer	P.50
ISO Sensitivity	P.51
Photometry	P.54
White balance	P.52

LCD monitor brightness/Volume adjustment

Holding down the “SHIFT” button and pressing the “DISP” button displays the menu. Use “▲▼” to select an option and “◀▶” to change the setting. Then press the “MENU/OK” button to confirm the setting.

Note that the volume can only be adjusted in Playback mode.

You've read the chapter on getting ready and the camera is now set up and ready to take pictures.

The Basic Photography section explains the three basic steps of "taking pictures", "viewing pictures" and "erasing pictures". Master the basic steps by actually trying them out on the camera as you go.



TAKING PICTURES (AUTO MODE)

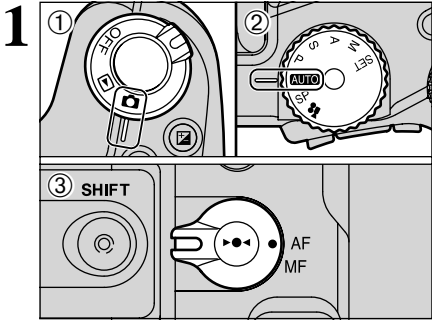

Set the Power switch ① to "📷" and the mode dial ② to "AUTO". Then set the focus mode selector switch ③ to "AF".

● **Shooting distance**

- Wide-angle: Approx. 50 cm (1.6 ft.) to infinity
- Telephoto-angle: Approx. 90 cm (3.0 ft.) to infinity

- 🔧 Set the mode to Macro for close-up shots (→ P.47).
- 🔧 Check that the lens is not soiled. If the lens is soiled, see P.81 for instructions on how to clean it.

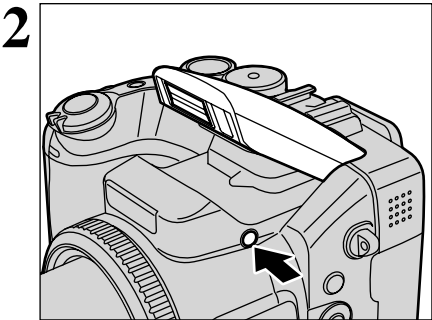

Press the flash pop-up button to pop up the flash.

- 🔧 If the "CARD ERROR", "WRITE ERROR", "READ ERROR" or "CARD NOT INITIALIZED" message appears, refer to P.84.
- 🔧 If the flash popped up and was used to take a picture, the screen may go dark briefly while the flash is charging. At the same time, the indicator lamp flashes orange.
- 🔧 If you use the flash while it is snowing or in very dusty conditions, the snowflakes or dust may reflect the flash and appear as white specks on the image.

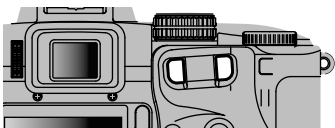

TAKING PICTURES (AUTO MODE)

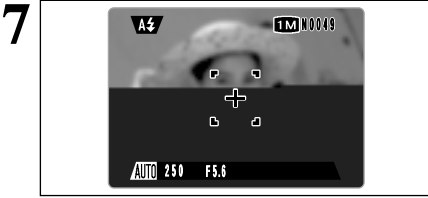

Frame the shot so that the subject fills the entire AF (Auto Focus) frame.

- ⚡ If the subject is not in the AF frame, use AF/AE lock to take the picture (⇒P.25).

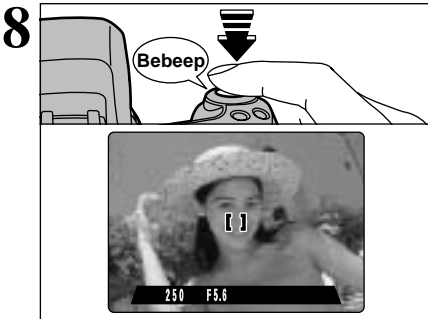

When you press the shutter button down halfway, the camera emits a short double-beep and focuses on your subject. At that point, the AF frame on the screen becomes smaller and the camera sets the shutter speed and aperture.

- ⚡ The image shown on the screen before you take the shot may differ in its brightness, color, etc. from the image actually recorded. If necessary, play back the recorded image to check it (⇒P.27).
- ⚡ If the camera does not emit a short double-beep and " ! AF " appears on the screen, the camera cannot focus.
- ⚡ When you press the shutter button down halfway, the image on the screen freezes temporarily. However, this image is not the recorded image.
- ⚡ If " ! AF " is displayed on the screen (e.g. the shot is too dark for the camera to focus), try standing about 2 m (6.6 ft.) from your subject to take the picture.

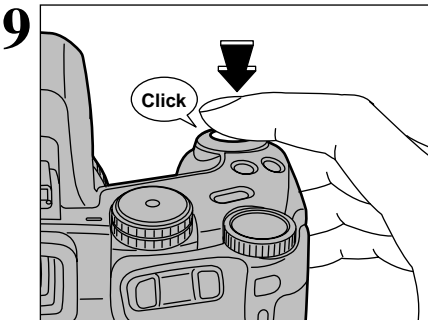

When you keep the shutter button pressed down halfway and then press it down further (pressed fully), the camera makes a soft clicking sound and takes the picture.

- ⚡ When the number of available shots is yellow, pictures cannot be taken until it turns white.
- ⚡ If you press the shutter button down fully in a single motion, the AF frame does not change size and the camera does not beep when the picture is taken.

■ Indicator Lamp Display

Display	Status
Lit green	Ready to shoot.
Blinking green	AF/AE operating or camera shake/AF warning (ready to shoot).
Blinking green and orange alternately	Recording data to the media (ready to shoot).
Lit orange	Recording data to the media (not ready to shoot).
Blinking orange	Charging the flash (flash will not fire).
Blinking red	<ul style="list-style-type: none"> ●Media-related warning. The media is not loaded, is not formatted, is incorrectly formatted or has a write-protect sticker attached (SmartMedia). Media full. Media fault. ●Lens operation error.

* Detailed warning messages are displayed on the screen (⇒P.84, 85).

USING AF/AE LOCK

1



In a shot with this type of composition, the subjects (two people in this case) are not in the AF frame. If the shot is taken at this point, the subjects will not be in focus.

2



Move the camera slightly so that one of the subjects is in the AF frame.

3



Keep holding the shutter button down halfway (AF/AE lock). Check that the AF frame shrinks and that the shutter speed and aperture settings are displayed (the indicator lamp (green) changes from blinking to lit).

4



Continue to hold the shutter button down halfway (AF/AE lock). Move the camera back to the original image and then fully press down on the shutter button.

- ✔ You can reapply the AF/AE lock as many times as you like before releasing the shutter.
- ✔ The AF/AE lock operates in all photography modes and can be used to ensure excellent results.

◆ AF/AE Lock ◆

On the FinePix S602 ZOOM, when you press the shutter button down half way, the focus and exposure settings are fixed (AF/AE lock). If you want to focus on a subject that is off to one side of the image or if you want to set the exposure before you compose the final shot, lock the AF and AE settings and then compose and shoot your picture to get the best results.

● When you cannot focus and AF/AE lock does not give the correct exposure

Position the AF frame over the main subject and apply the AE lock (➡P.47). Then position the AF frame over another subject at roughly the same distance, press the shutter button down halfway, recompose the shot and then take the picture.

TAKING PICTURES (AUTO MODE)

DIGITAL ZOOM

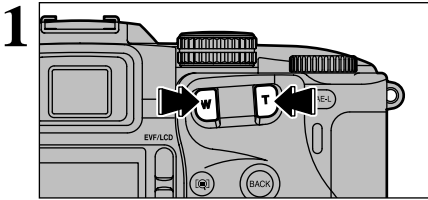

The digital zoom can be used with the “**3M**”, “**1M**” and “**VGA**” number of recorded pixels settings.

- ! The digital zoom cannot be used with the “**6M**” setting.
- ! See P.69 for information on changing the number of recorded pixels setting.
- ! If the shot goes out of focus during zooming, hold the shutter button down halfway to refocus the shot.

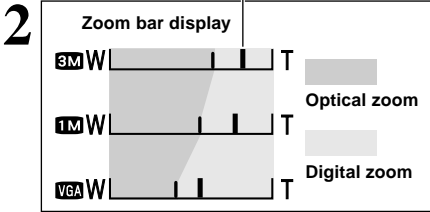

The position of the “**I**” indicator on the zoom bar shows the zooming status.

- The area to the right of the separator indicates digital zooming, while the area to the left indicates optical zooming.
- Pressing the zoom buttons moves the “**I**” indicator left or right.
- When zooming switches between digital and optical, the “**I**” indicator stops. Pressing the same zoom button again starts the “**I**” indicator moving again.

● Digital zoom focal lengths (35 mm camera equivalents)

3M: Approx. 210 mm-294 mm, max. zoom scale: 1.4×

1M: Approx. 210 mm-462 mm, max. zoom scale: 2.2×

VGA: Approx. 210 mm-924 mm, max. zoom scale: 4.4×

- ! The optical zoom focal length is equivalent to approx. 35 mm-210 mm (35 mm camera equivalent).

BEST FRAMING

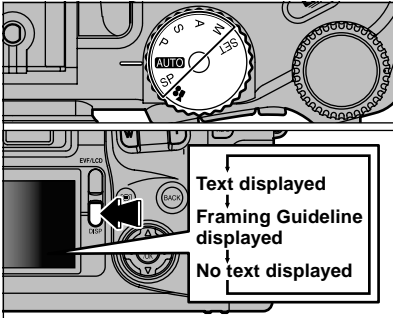

This function can be selected in the “**AUTO** • SP • P • S • A and M” photography modes. The screen display changes each time you press the “**DISP**” button. Press the “**DISP**” button to display the framing guideline.

- ! The framing guideline is not recorded on the image.
- ! The lines in the scene frame divide the recorded pixels into 3 roughly equal parts horizontally and vertically. When the image is printed, the resulting print may be shifted slightly from the scene frame.

Scene

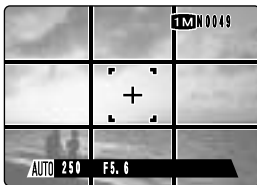

Use this frame with main subject positioned at the intersection of two lines or align one of the horizontal lines with the horizon.

This frame allows you to compose your own shots while remaining aware of the subject's size and the balance of the shot.

◆ Important ◆

Always use AF/AE lock when composing a shot. The image may not be focused correctly if you do not use AE/AF lock.

VIEWING YOUR IMAGES (PLAYBACK)

VIEWING YOUR IMAGES (PLAYBACK)

Playback Zoom

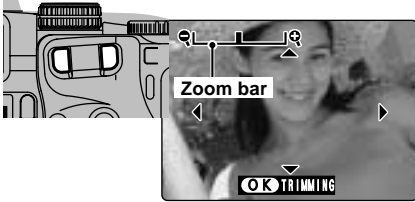

Pressing the zoom button during single-frame playback zooms (enlarges) the still image. When you do this, a zoom bar is displayed.

● Zoom scales

- 6M** 2832 × 2128 pixel images: Max. 18×
- 3M** 2048 × 1536 pixel images: Max. 13×
- 1M** 1280 × 960 pixel images: Max. 8×
- VGA** 640 × 480 pixel images: Max. 4×

⚠ You cannot use multi-frame playback during playback zoom.

Panning

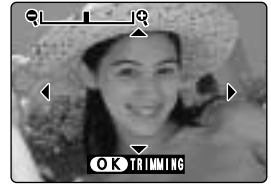

You can view another area by pressing "▲▼◀▶".

The size of a saved image varies depending on the zoom scale. For VGA, the "OK TRIMMING" option appears in yellow. For levels below VGA, the "OK TRIMMING" message is not shown.

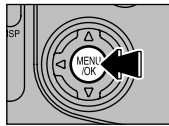

Press the "MENU/OK" button to trim the image.

Trimming



Check the size of the saved image and press the "MENU/OK" button. The trimmed image is saved as a separate file.

■ Number of recorded pixels

3M	suitable for printing (A5 size (6" × 8") or smaller)
1M	suitable for printing (A6 size (4" × 8") or smaller)
VGA	The trimming option is displayed in yellow since the image quality is too poor for printing.

* Because the number of recorded pixels lower than **VGA** are not suitable for printing, the trimming option is not displayed and trimmed images cannot be saved.

Erasing Images (Erase Frame)

1

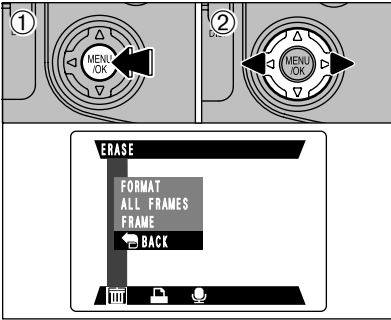

① Press the “MENU/OK” button during playback to display the menu.

② Press “◀” to select “ERASE”.

2

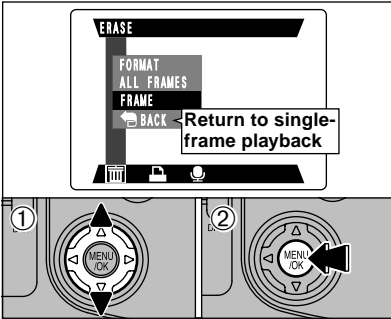

① Press “▲▼” to select “FRAME”.

② Press the “MENU/OK” button to confirm the selection.

See P.62 for information on erasing all the “ALL FRAMES” and “FORMAT” (initializing).

3

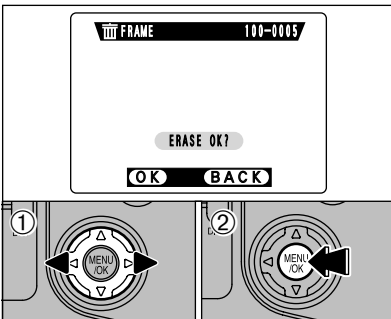

① Press “◀▶” to select the frame (file) to be erased.

② Press the “MENU/OK” button to erase the displayed frame (file).

To erase another image, repeat steps ① and ②.

Note that erased images cannot be restored.

FOCUSING

The distance from the subject to the camera is referred to as the shooting distance. When the shooting distance is set correctly and the image appears sharp, the image is focused.

■ Two Focusing Methods: AF and MF.

The mechanisms for focusing are AF (auto focus) and MF (manual focus).

AF: The camera automatically focuses on the subject in the AF frame. The camera focuses when you press the shutter button down halfway.

◆ The AF Sensor ◆

The FinePix S602 ZOOM uses an external AF sensor (external-light passive phase difference AF) that features faster AF operation than previous models. The external AF sensor does not operate in Macro or Super Macro mode, when the digital zoom or AREA AF is used, or when "SET ADAPTER RING - YES" is specified. Focusing may take longer if the external AF sensor is soiled (➡P.86).

MF: Turn the focusing ring to focus the shot.

■ Causes of Focusing Errors and the Solutions

Cause	Solution
The subject is not in the AF frame.	Use AF lock (*1) or MF.
The subject is not suited to AF.	Use AF lock (*1) or MF.
The subject is outside the shooting range.	Switch Macro mode on or off (*2).
The subject is moving too quickly.	Use MF (pre-setting the shooting distance for a shot (lock pin))

*1 Taking pictures using AF lock

Press the shutter button down halfway to focus.



Capture the subject

Recompose the shot and take the picture.

*2 Switching Macro mode ON/OFF

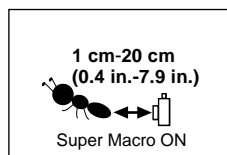
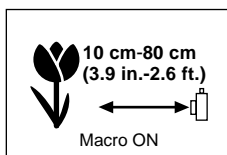
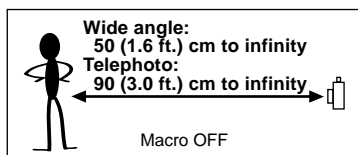

◆ Subjects Not suitable for Auto Focus ◆

- Very shiny subjects such as a mirror or car body.
- Subjects photographed through glass.
- Subjects that do not reflect well, such as hair or fur.
- Subjects with no substance, such as smoke or flames.
- When the subject is dark.
- When there is very little contrast between the subject and the background (such as white walls or subjects dressed in the same color as the background).
- Subjects moving at high speed.
- When something other than your subject is close to the AF frame, has contrasting areas of light and dark and is either closer or further away than your subject (as when you photograph someone against a background with strongly contrasting elements).

EXPOSURE (APERTURE AND SHUTTER SPEED)

EXPOSURE

Exposure refers to the light that hits the CCD or the total amount of captured light and determines the brightness of the image.

The exposure is determined by the combination of aperture and shutter speed. In AE (automatic exposure), the camera automatically determines the correct exposure, allowing for factors such as the brightness of the subject and the ISO setting.

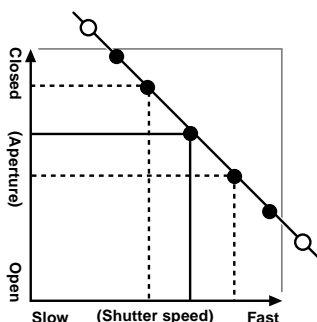

The graph at left shows the way the aperture and shutter speed settings can be changed while maintaining the same exposure level.

- When the exposure is decreased by one step, the shutter speed also decreases by one step (the dot moves up and left).
- When the exposure is increased by one step, the shutter speed also increases by one step (the dot moves down and right).
- Combinations that result in the shutter speed or aperture being outside the available range of settings cannot be selected (white dots).
- In the P, S and A photography modes, it is easy to select different settings along this line.
- Selecting settings that run parallel to this line by adjusting the brightness of the photographed image is referred to as exposure compensation.

◆ When You Cannot Get the Correct Exposure ◆

AE lock: Determines and fixes the exposure at a target level. Use the following procedure to take a picture using AE lock:

- ➔ Press the "AE-L" button (sets and locks the exposure).
- ➔ Press the shutter button down halfway (sets and fixes the focus).
- ➔ Press the shutter button down fully (takes the picture).

Exposure compensation:

This function uses the exposure level set by the AE function as a reference (0) and then brightens (+) or darkens (-) the image. By selecting Auto Bracketing, you can shoot 3 frames, one underexposed (-), one at the reference exposure (0) and one overexposed (+).



(-)



(0)



(+)

Shutter Speed

When you are shooting a moving subject, you can either "freeze the motion" or "capture the sense of movement" by adjusting the shutter speed.



Freezes the motion of the subject.



Photographs the traces left by the subject's movement.

Aperture

By adjusting the aperture, you can change the depth of focus (depth of field).

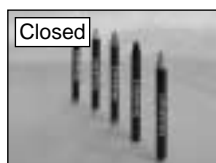

The area in front of and behind the subject is also in focus in the shot.

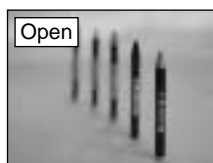

The background is out of focus.

TAKING PICTURES — SELECTING THE CAMERA SETTINGS

Consider the scene you are photographing and the sort of image you want to achieve when you specify the camera settings. A general guide to the procedure is given below.

1 Select the photography mode (⇒P.34-40).

- AUTO** Leaves all the settings to the camera.
- SP** Selects photography modes tailored to the scene being shot.
- P/S/A** Allows you to change the aperture or shutter speed setting so that the action is frozen, so that the flow of the motion is conveyed, or so that the background is out of focus.
- M** Allows you to adjust all the camera settings yourself.
- Movie** Shoots a movie.

2 Specify the Required Photography Function Settings (⇒P.41-48).

- Flash** Use the flash for shots in dark locations or for backlit subjects, etc.
- Macro/Super Macro** Use these functions for close-up shots.
- AE-L AE Lock** Fixes the exposure settings.
- Exposure compensation** Using the AE exposure as a reference value of 0, this function brightens (+) or darkens (-) the shot.
- AF/MF switch** Selects either automatic focusing (AF) or manual focusing (MF).
- Continuous shooting** Allows you to take a series of continuous shots or to use auto bracketing (with exposure compensation).

3 Take the Photograph (check the exposure and focus ⇒ adjust the shot composition ⇒ press the shutter button down fully).

★ You can Use the Menus for More Detailed Settings (⇒P.49-58).

The table below provides a number of sample settings. You can achieve any number of other effects by using the settings effectively. Try changing different settings to see what kind of shots you can take.

To achieve this result	Sample settings
To express the motion of the subject (the flow of time)	Set the Mode dial to "S" and select a slow shutter speed. (Use a tripod to avoid camera shake.)
To freeze the subject's movement	Set the Mode dial to "S" and select a fast shutter speed.
To make the subject stand out by having the background out of focus	Set the Mode dial to "A" and select a wide aperture setting.
To get a very large depth of focus	Set the Mode dial to "A" and select a narrow aperture setting.
To prevent the image having a red or blue cast due to the light source	Change the "White balance" setting in the photography menu.
To avoid missing snapshot opportunities	Take pictures in AUTO mode (see "Basic Photography").
To prevent the subject from being overexposed or underexposed and to show the substance and textures of the subject clearly.	Use exposure compensation. Select (+) if the background is pale and (-) if the background is dark.
To merge multiple images in an artistic composition	Use multiple exposures. For multiple exposures, exposure compensation is generally set to a negative value depending on the number of exposures. 2 exposures: -1.0 EV; 3 exposures: -1.5 EV; 4 exposures: -2.0 EV

■ List of Functions Available in Each Mode

Photography mode		AUTO	SP					P	S	A	M	👤
			Portrait	Landscape	Sports	Night Scene	Monochrome					
Function												
Flash	⚡ Auto Flash	YES	YES	NO	YES	NO	YES	NO	NO	NO	NO	
	👁 Red-Eye Reduction	YES	YES	NO	NO	NO	YES	YES	YES	YES	NO	
	⚡ Forced Flash	YES	YES	NO	YES	NO	YES	YES	YES	YES	NO	
	⚡ S Slow Synchro	YES	YES	NO	NO	YES	YES	YES	NO	YES	NO	
	👁 Red-Eye + Slow	NO	NO	NO	NO	YES	NO	YES	NO	YES	NO	
👤 Macro/👤 Super Macro*	YES	NO	NO	NO	NO	YES	YES	YES	YES	YES	NO	
AE-L AE Lock		YES		YES			YES	YES	YES	NO	NO	
📷 Exposure Compensation		NO		NO			YES	YES	YES	NO	NO	
AF/MF Switching		YES		YES			YES	YES	YES	YES	NO	
Continuous shooting Selections*	Frame (OFF)	YES		YES			YES	YES	YES	YES	NO	
	📷 Top 5-frame	YES		YES			YES	YES	YES	YES	NO	
	📷 Auto Bracketing	NO		NO			YES	YES	YES	YES	NO	
	📷 Final 5-frame	YES		YES			YES	YES	YES	YES	NO	
	📷 Long-period (up to 40 frames)	YES		NO			NO	NO	NO	NO	NO	

* Flash cannot be used with Super Macro or Continuous Shooting.

■ List of Menu Options Available in Each Mode

		Factory Defaults	AUTO	SP	P	S	A	M	👤
Menu Options	⌚ Self-timer	OFF	YES	YES	YES	YES	YES	YES	NO
	ISO Sensitivity	200	NO	NO	YES	YES	YES	YES	NO
	WB White Balance	AUTO	NO	NO	YES	YES	YES	YES	NO
	[O] Photometry	MULTI	NO	NO	YES	YES	YES	YES	NO
	📷 Auto Bracketing	± 1/3 EV	NO	NO	YES	YES	YES	YES	NO
	📷 Sharpness	NORMAL	NO	NO	YES	YES	YES	YES	NO
	📷 Multi-Expose	OFF	NO	NO	YES	YES	YES	YES	NO
	⚡ Flash (brightness adjustment)	0	NO	NO	YES	YES	YES	YES	NO
	📷 External Flash	OFF	NO	NO	YES	YES	YES	YES	NO
	🗣 Voice Memo	OFF	YES	YES	YES	NO	NO	NO	NO

When shutter speed and aperture adjustments alone do not give the correct exposure.

When the image is too bright

Lower the ISO sensitivity setting.
Use an ND filter (Commercially available).

When the image is too dark

Raise the ISO sensitivity setting.
Use flash or the brightness adjustment function.
Use a tripod (Commercially available).

R AUTO

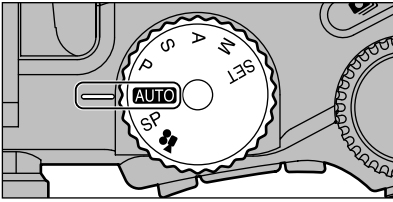

Set the Mode dial to “R”.

This is the easiest mode to use and can be used for most types of shot.

> SCENE POSITION

1

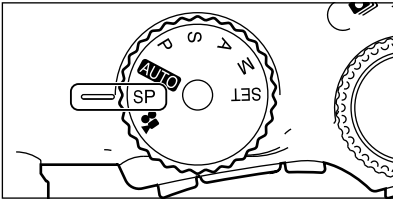

Set the Mode dial to “>”.

This mode provides options tailored to different types of scene.

2

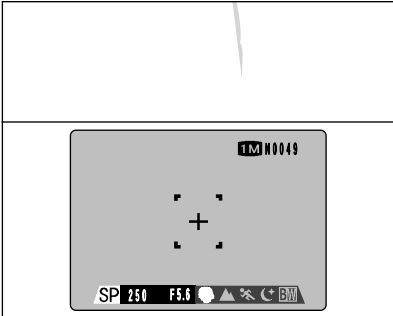

In “SP” mode, you can choose from 5 types of scene (“E”, “L”, “S”, “N” and “+”). Turn the command dial to select the scene.

In the “R” and “>” modes, the sensitivity is set to ISO 200.

	Explanation	Available flash modes
E Portrait	This is the best mode for shooting portraits. Skin tones are shown beautifully and the overall tone is soft.	C • n • z • v
, Landscape	This is the best mode for shooting scenery in daylight and provides crisp, clear shots of scenery such as buildings and mountains.	Flash not available
. Sports	This is the best mode for shooting sporting events. This mode gives priority to faster shutter speeds.	C • z
/ Night Scene	This is the best mode for evening and night scenes. This mode allows you to take shots where priority is given to slow shutter speeds of up to 3 seconds.	! • v
+ Monochrome	Use this mode to shoot pictures in black and white, regardless of the scene you are shooting.	C • n • z • v

Except for “+” Monochrome, Macro mode cannot be used with any of the SP modes.

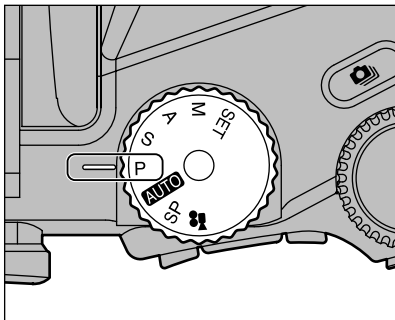

Set the Mode dial to "B".

This is an automatic mode that allows you to specify any of the settings other than the shutter speed and aperture. This allows you to take shots relatively simply in the same way as the Shutter-priority Auto and Aperture-priority Auto modes (program shift).

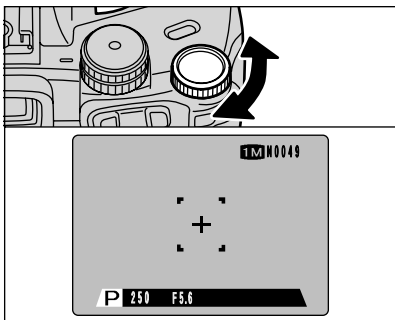

Program Shift

By turning the command dial, this mode allows you to select different shutter speed and aperture setting combinations without changing the exposure setting. The shutter speed and aperture setting are displayed in yellow when the camera is in Program Shift mode.

Program Shift is automatically cancelled in the following situations:

- When the photography mode is changed
- When the flash is popped up
- When "μ" EXTERNAL FLASH in the Main menu is set to "ON".
- When you switch to playback mode
- When the camera is switched off.

◆ The Shutter Speed and Aperture Setting Display ◆

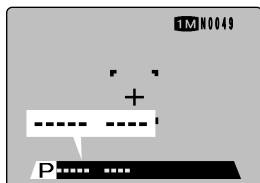

When the brightness of the subject is outside the camera's brightness metering range, "-----" is displayed as the shutter speed and aperture setting on the screen.

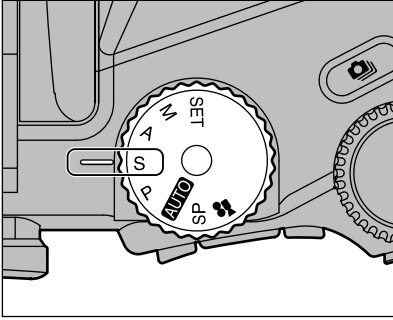

Set the Mode dial to "M".

This is an automatic mode that allows you to set the shutter speed. You can use this mode for shots where you want to freeze a moving subject (fast shutter speed) or convey the impression of movement (slow shutter speed).

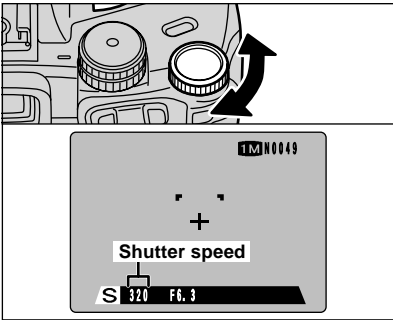

You can select the shutter speed by turning the command dial.

● **Shutter speed settings**

3 sec. to 1/1000 sec.

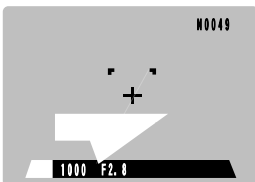

In scenes that are extremely underexposed, the aperture setting (F2.8) is displayed in red. When this occurs, select a slower shutter speed (down to 3 sec.).

When the brightness of the subject is outside the camera's brightness metering range, "----" is displayed as the shutter speed setting. When this occurs, press the shutter button down halfway to measure the light level again and display a value.

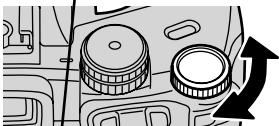
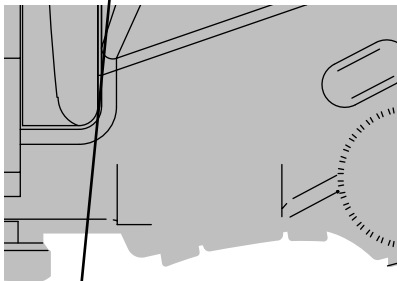

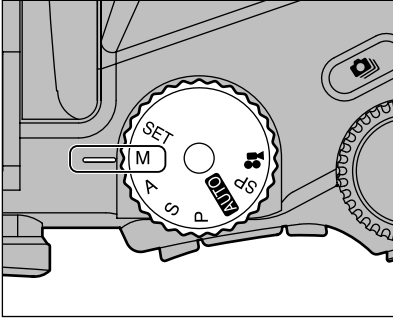

Set the Mode dial to “< ”.
Manual mode allows you to set any shutter speed and aperture setting.

- **Shutter speed settings**
15 sec. to 1/10000 sec.
- **Aperture settings**
F2.8 to F11 in 1/3 EV steps

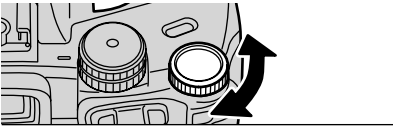

Setting the shutter speed

You can select the shutter speed by turning the command dial.

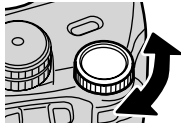

Setting the aperture

Select the aperture by holding down the “L” exposure compensation button ① and turning the command dial ②.

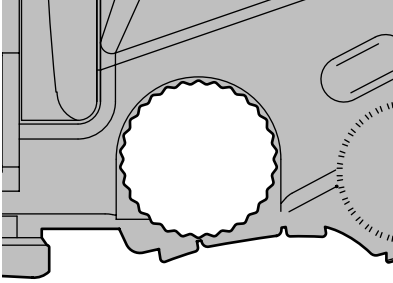

Number of recorded pixels	VGA	QVGA
MG-4S (4 MB)	Approx. 3 sec.	Approx. 6 sec.
MG-8S (8 MB)	Approx. 6 sec.	Approx. 13 sec.
MG-16S/SW (16 MB)	Approx. 13 sec.	Approx. 27 sec.
MG-32S/SW (32 MB)	Approx. 27 sec.	Approx. 55 sec.
MG-64S/SW (64 MB)	Approx. 55 sec.	Approx. 110 sec.
MG-128SW (128 MB)	Approx. 112 sec.	Approx. 222 sec.
Microdrive 340 MB	Approx. 307 sec.	Approx. 609 sec.
Microdrive 1 GB	Approx. 925 sec.	Approx. 1833 sec.

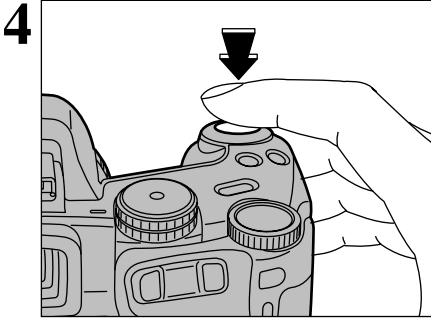

Press the shutter button down fully to start shooting.

- ⚠ The brightness and color of the screen shown during movie shooting may differ from those shown before shooting begins.
- ⚠ You do not need to hold down the shutter button.

When you press the shutter button down fully, the focus and white balance are fixed, but the exposure is automatically adjusted to suit the scene being shot.

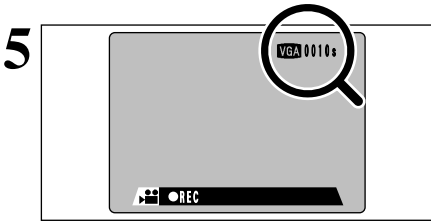

A counter displayed in the top-right corner of the screen during shooting shows the remaining time.

- ⚠ If the brightness of the subject changes while you are shooting a movie, the sound of the aperture operating may be recorded in the movie.
- ⚠ When the remaining time runs out, shooting automatically ends and the movie is recorded onto the media.

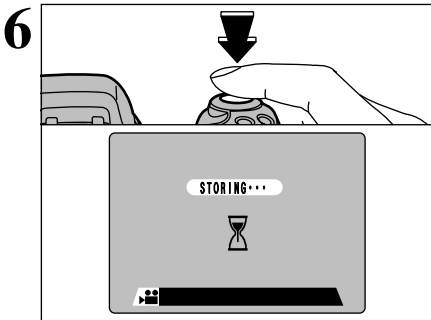





Pressing the shutter button during shooting ends movie shooting and the movie is recorded onto the media.

- ⚠ If shooting is stopped immediately after it begins, only 1 second of movie is recorded onto the media.

When shooting long movies, it is recommended that you use a fully charged Ni-MH (nickel-metal hydride) batteries.

FLASH PHOTOGRAPHY

( SP (EXCLUDING ,)  P  S  A  M

FLASH PHOTOGRAPHY



C Auto Flash

Use this mode for ordinary shots. The flash fires automatically according to the photography conditions.



n Red-Eye Reduction

Use this mode to ensure that the subject's eyes appear natural when photographing people in low-light conditions.

The flash fires a pre-flash just before the picture is taken and then fires again to take the actual picture.

⚡ In the "R" and ">" modes, the flash fires automatically according to the photography conditions.

◆ Red-Eye Effect ◆

When you use the flash to photograph people in low-light conditions, their eyes sometimes appear red in the picture. This is caused by the light of the flash reflecting off the inside of the eye. Use Red-Eye Reduction flash to effectively minimize the likelihood of the red-eye effect.

Take the following measures to make Red-Eye Reduction more effective:

- Get the subjects to look at the camera.
- Get as close as possible to the subjects.



Z Forced Flash

Use this flash mode to photograph backlit scenes, such as a subject against a window or in the shade of a tree, or to obtain the correct colors when you are shooting under lighting such as fluorescent tubes. In this mode, the flash fires in bright as well as dark conditions.



v Slow Synchro

This is a flash mode that uses a slow shutter speed. This allows you to take pictures of people at night that clearly show both your subjects and the nighttime backdrop.

! Red-Eye Reduction + Slow Synchro

Use this mode for slow synchro shots with red-eye reduction.

- ⚡ The image may be overexposed when you shoot bright scenes.
- ⚡ Because a slow shutter speed is used, a tripod should be used to prevent camera shake.

To take a picture of a main subject at night with the background brightly lit, please use the ">" mode " / " (Night Scene) settings (➡P.34).

CONTINUOUS SHOOTING

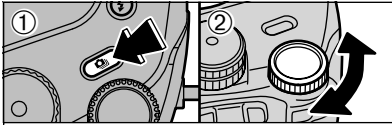

Hold down the “t” button ① and turn the command dial ② to select the desired continuous shooting mode. Releasing the “t” button confirms your selection.

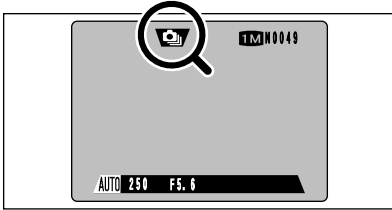
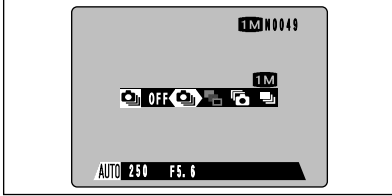

When you set the continuous shooting mode (except for “OFF”), the selected mode appears on the screen.

- t : Top 5-frame continuous shooting
- [: Auto bracketing
-] : Final 5-frame continuous shooting
- A : Long-period continuous shooting with 1280 × 960-pixel mode

◆ Notes on Using the Continuous Shooting Modes ◆

- Shooting continues for as long as you hold down the shutter button. In Auto Bracketing mode however, just press the shutter button once to shoot 3 frames.
- If there is insufficient space on the media, as many frames are shot as can be recorded on the available space. For auto bracketing however, if there is insufficient space on the media to record 3 frames, no shots are taken.
- The focus is determined in the first frame and cannot be changed in mid-sequence.
- The exposure is determined in the first frame, but in Long-period continuous shooting with 1280 × 960-pixel mode the exposure is automatically adjusted for the scene being shot.
- The speed of continuous shooting varies depending on the shutter speed.
- The speed of continuous shooting does not change with the number of recorded pixels and quality settings.
- The flash cannot be used as the flash mode is set to Suppressed Flash.
- Always check the photographed images after shooting. To select and record your images, preview them in “PREVIEW” in the SET-UP menu (➔P.70).

Continued over page...

CONTINUOUS SHOOTING

t Top 5-frame Continuous Shooting

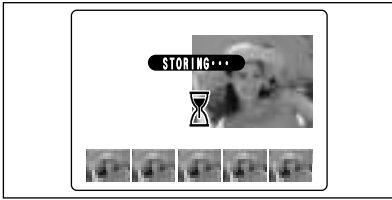

In this mode, you can shoot up to 5 frames at intervals as short as 0.2 seconds. When you take the shots, the photographed images are displayed (in sequence from the left) and automatically recorded.

[Auto Bracketing

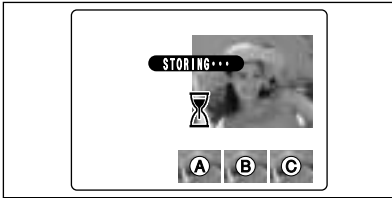

This mode automatically shoots 3 continuous frames that bracket the selected setting so that one image is correctly exposed (A), one is overexposed (B) and one is underexposed (C). The settings (exposure range) can be changed in the photography menu.

● Auto Bracketing settings (3)

±1/3 EV, ±2/3 EV, ±1 EV

- ⚠ If the underexposed or overexposed frame is outside the camera's control range, the shot is not taken with the specified setting increments.
- ⚠ Auto Bracketing cannot be used in "R" or ">" mode.

A Long-period Continuous Shooting with 1280 × 960-pixel mode

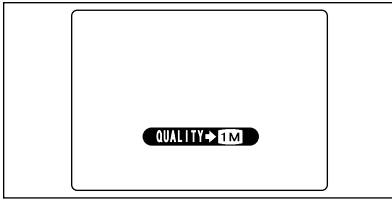

This mode allows you to take up to 40 continuous shots (at intervals as short as 0.6 seconds). In Long-period Continuous Shooting with 1280 × 960-pixel mode, the number of recorded pixels is automatically set to "1" (1280 × 960 pixels). You can select NORMAL or FINE as the quality setting (⇒P.69).

- ⚠ If you cancel Long-period Continuous Shooting with 1280 × 960-pixel mode, the resolution setting remains at "1".
- ⚠ Long-period Continuous Shooting with 1280 × 960-pixel mode cannot be used in the "> • B • M • N" or "<" modes.
- ⚠ When a Microdrive is used, the intervals between shots are longer due to the characteristics of Microdrives.

◆ Focusing on a Moving Subject ◆

If you press the shutter button down halfway to focus on the subject at the starting point (A), the subject may no longer be in focus when it reaches point (B) where you want to take the shot. In such situations, use AF lock or manual focusing to focus on point (B) beforehand and then lock the focus so that it does not shift (lock pin). The lock pin feature is also useful for photographing fast-moving subjects that are difficult to focus on.

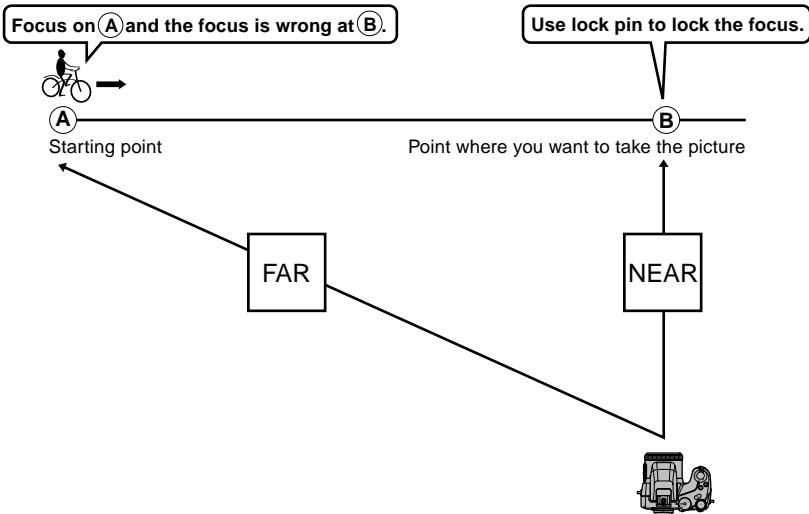

Use this function for shots where you cannot obtain the optimum brightness (exposure), such as shots with extremely high contrast between the subject and the background.

- ⚠ Exposure compensation cannot be used in the "R", ">" or "<" modes.
- ⚠ Exposure compensation is disabled in the following situations:
 - When "z" (Forced Flash) or "n" (Red-Eye Reduction) mode is used and the scene photographed is dark.

◆ Subjects for Which Exposure Adjustment is Particularly Effective ◆

Exposure indicator moved towards + (plus)

- Copying of printed text (black characters on white paper) +4 steps (+1.3 EV)
- Backlit portraits +2 to +4 steps (+0.7 EV to +1.3 EV)
- Very bright scenes (such as snowfields) and highly reflective subjects +3 steps (+1 EV)
- Shots made up predominantly of sky. +3 steps (+1 EV)

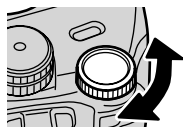

To select the Exposure Compensation setting, hold down the "L" button ① and turn the Command dial ②. The "L" symbol also turns yellow while exposure compensation is being set and then turns blue after setting is completed.

- **Compensation range:** -2 EV to +2 EV, in 1/3 EV steps

This setting is retained when the mode is switched or the camera is switched off (The "d" icon is displayed). Set the exposure compensation to "0" unless compensation is required.

AE-L USING AE LOCK/e MACRO (CLOSE-UP) PHOTOGRAPHY

S USING AE LOCK

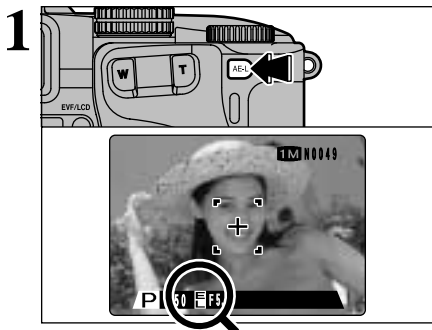

Use this function when you want to take pictures with the exposure fixed for a particular subject. Frame the shot so that the subject occupies most of the center of the screen and then press the “S” button.

The “%” icon appears on the screen and the exposure is locked while you hold down the “S” button.

- ⚠ This function cannot be used in “<” photography mode or for Long-period continuous shooting with 1280 × 960-pixel mode.

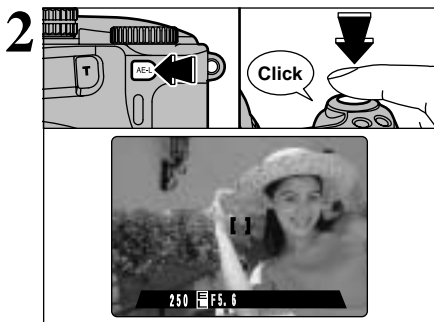

With the “S” button held down, press the shutter button down halfway to focus the shot and then compose the shot again.

- ⚠ Once you press the shutter button down halfway, the exposure remains locked even if you release the “S” button.
- ⚠ When the AE lock is applied, pressing the shutter button down halfway only sets the focus.

e MACRO (CLOSE-UP) PHOTOGRAPHY

(+ only)

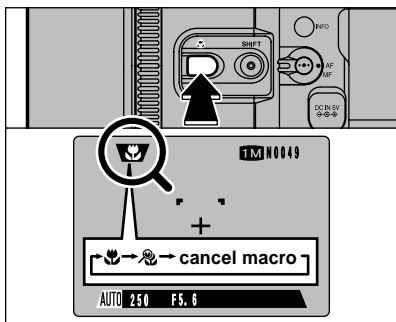

Selecting Macro mode allows you to take close-up shots.

The Macro mode setting changes each time you press the “e” button.

- ⚠ Macro mode is automatically cancelled in the following situations:
 - When the photography mode is changed to “>” (excluding +) • “T” or “~”
 - When you switch to playback mode
 - When the camera is switched off.
- ⚠ If the flash is too bright, use flash brightness adjustment (→P.56).
- ⚠ A tripod should be used to avoid camera shake.

3

Advanced Features Photography

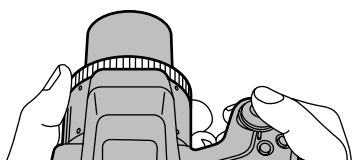

PHOTOGRAPHY MENU

PHOTOGRAPHY MENU OPERATION

1

- ① Press the “MENU/OK” button to display the menu.
- ② Use “◀▶” to select a menu option and then press “▲▼” to change the setting.
- ③ Press the “MENU/OK” button to confirm the setting.

⚠ You cannot specify menu settings in “T” mode.

2

Pressing “◀▶” moves to the next or previous menu page as indicated by “◁▷” at the end of the page.

◆ Photography Information ◆

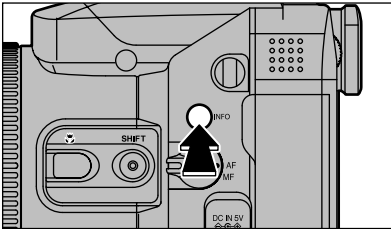

If you cannot recall the current photography settings, you can check them by holding down the “INFO” button.

- ⚠ The photography information is not displayed in “R” mode.
- ⚠ You can only use this function to check the settings, not to change them.

Flash brightness adjustment

White balance

Photometry

ISO Sensitivity

Sharpness

1M 0049

±:0

WB: AUTO

[O]: MULTI

ISO: 200

S: NORMAL

P 250 F5.6

PHOTOGRAPHY MENU

= SELF-TIMER PHOTOGRAPHY

1

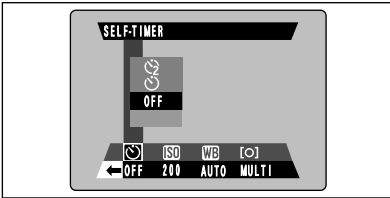

When you select the self-timer function, the self-timer icon appears on the screen.

= : The shot is taken after 10 seconds.

@ : The shot is taken after 2 seconds.

⚙ The self-timer function is automatically cancelled in the following situations.

- When a self-timer shot has been taken
- When the Mode dial is moved to another setting
- When the camera is switched to Playback mode
- When the camera is switched off

f SETTING THE ISO SENSITIVITY

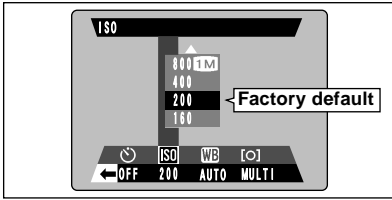

Use this setting if you want to take bright shots in low light conditions (such as indoors) without using the flash, or if you want to use a faster shutter speed (to avoid camera shake, etc.).

- **Settings:** 160, 200, 400, 800, 1600

Setting the Mode dial to “R ->” or “~” cancels high-sensitivity photography (ISO 800/1600) and resets the camera to ISO 200. However, the number of recorded pixels is still set to “1” and “NORMAL”.

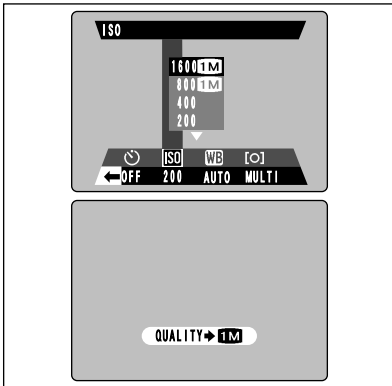

High-sensitivity Photography (ISO 800/1600)

If you select a high sensitivity setting (ISO 800 or 1600), the number of recorded pixels is automatically set to “1” and NORMAL.

- ⚡ High-sensitivity photography is automatically cancelled in the following situations:
 - When playback mode is selected
 - When the camera is switched off
- ⚡ The digital zoom cannot be used for high-sensitivity shots.
- ⚡ While higher sensitivity settings are more suited to dark situations, the amount of noise appearing on the image increases. Use the appropriate setting for your shot.

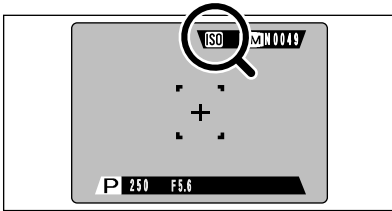

When you use a high sensitivity setting, “f” appears on the screen.

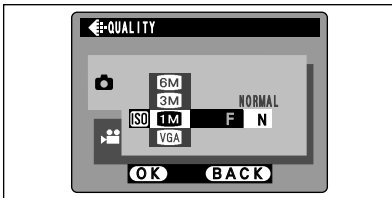

If you hold down the “SHIFT” button and press the “MENU/OK” button, the menu is displayed but the QUALITY setting cannot be changed from “1” and NORMAL.

PHOTOGRAPHY MENU

a SETTING THE WHITE BALANCE

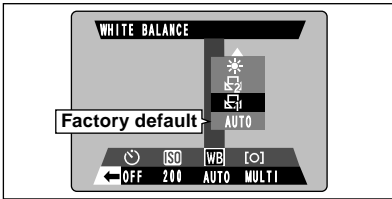

Change the white balance setting when you want to take a picture with the white balance fixed for the surroundings and lighting when the picture is taken.

In Auto mode, the correct white balance may not be obtained for subjects such as close-ups of people's faces and shots taken under a special light source. In such situations, select the correct white balance for the light source. See P.89 for more information on the white balance.

AUTO: Automatic adjustment
(Shooting to show the ambience of the light source)

) : Custom white balance type 1

_ : Custom white balance type 2

6 : Shooting outdoors in fine weather

7 : Shooting in shade

9 : Shooting under "Daylight" fluorescent lamps

0 : Shooting under "Warm White" fluorescent lamps

- : Shooting under "Cool White" fluorescent lamps

8 : Shooting in incandescent light

*The white balance setting (unless it is a Custom White Balance setting) is ignored when you use the flash. To achieve the desired effect in your shot, press the flash back down to suppress flash operation (►P.41).

1

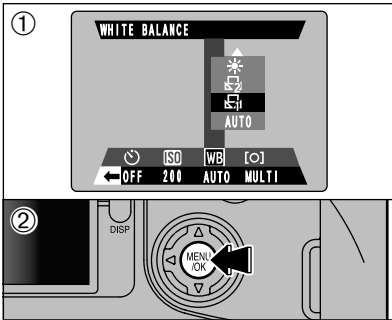

Custom White Balance

Use this function when you want to set the white balance for the ambient natural or artificial lighting in your shots. You can also use this function to achieve special effects.

① Select custom white balance ") " or " _ ".

② Press the "MENU/OK" button.

◆ Example ◆

You can deliberately change the white balance for a photographed image by using colored paper instead of white paper.

2

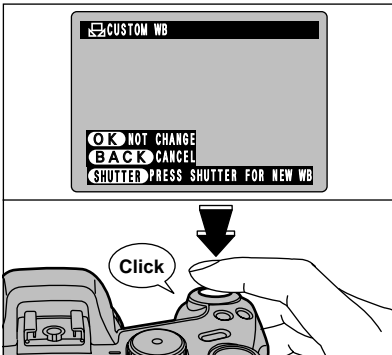

Under the light source you want to set the white balance for, hold a piece of white paper so that it fills the screen and press the shutter button to set the white balance.

⚠ The white balance setting does not affect the image shown on the screen.

To use the white balance set previously, press the "MENU/OK" button without pressing the shutter button.

3

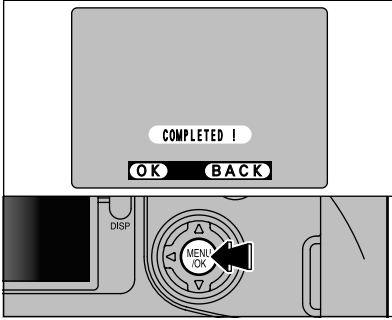

When the correct exposure is measured, " " is displayed. Press the "MENU/OK" button to confirm the setting.

- The specified custom white balance is retained until it is reset.
- After you take the picture, you should check the "Color (White Balance)" setting for the image.
 - Set "IMAGE DISPLAY" in the SET-UP menu to "PREVIEW" (⇒P.70).
 - Set Power switch to "Q" (⇒P.18).

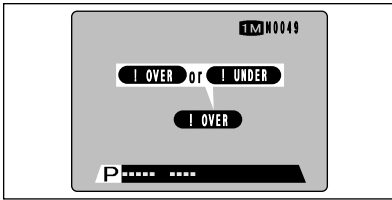

If " " or " " is displayed, the white balance was not measured at the correct exposure. Reset the white balance.

PHOTOGRAPHY MENU

S PHOTOMETRY

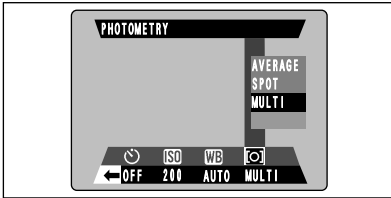

Use this mode for scenes where the brightness of the subject and background differ markedly so that the Multi setting is unlikely to achieve the desired result.

AVERAGE: Light metering where an average value for the entire image is used.

SPOT : Light metering where the exposure is optimized for the center of the image.

MULTI : Light metering where the camera automatically assesses the scene and selects the optimum exposure.

🔍 In the "R" and "T" modes, light metering is fixed at the "MULTI" setting and cannot be changed.

◆ The Light Metering Modes are Effective for the Following Subjects ◆

- **AVERAGE**

The advantage of this mode is that the exposure tends not to change for different compositions or subjects. This mode is particularly effective for shots of people wearing black or white clothing and shots of scenery.

- **SPOT**

This mode is useful for subjects with strongly contrasting light and dark areas where you want to achieve the correct exposure for a particular feature.

- **MULTI**

In this mode, the camera uses automatic scene recognition to analyze the subject and provide optimum exposure in a wide range of shooting conditions. This mode should be used for everyday photography.



K SHARPNESS

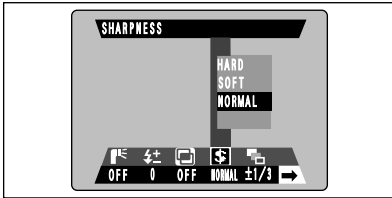

Use this setting to soften or emphasize outlines or to adjust the image quality.

HARD : Emphasizes the outlines.

Best for shots of subjects such as buildings or text where you want sharp images.

SOFT : Softens the outlines.

Best for shots of subjects such as people, where a softer image is desirable.

NORMAL: Best for ordinary photography.

Provides edge sharpness that is ideal for ordinary shots.

* MULTI-EXPOSURE

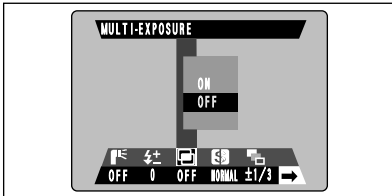

Multiple-exposure provides a way of overlaying photographed images on top of each other to give a final image that cannot be obtained through normal photography.

⚡ If the photographed image is overexposed, use negative compensation in the Brightness (exposure compensation) setting to correct the exposure (⇒P.46).

⚡ Only the optical zoom can be used for multi-exposure shots. The digital zoom (⇒P.26) does not function.

⚡ This mode is automatically cancelled when you switch the camera off.

- Continuous shooting and Auto bracketing are disabled when MULTI-EXPOSURE is selected.
- You cannot change the photography menu settings or the FILE SIZE/QUALITY setting during shooting.
- There is no limit on the number of multiple exposures.

1

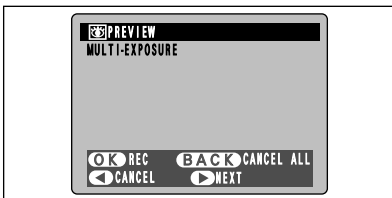

A preview screen appears when you take a picture.

● To overlay more images: Press “▶”.

● To record the image: Press the “MENU/OK” button.

● To return to the previous image: Press “◀”.

● To stop without recording any images:

Press the “BACK” button.

⚡ A preview image is always shown, regardless of the IMAGE DISPLAY setting. However, note that the Preview Zoom function cannot be used (⇒P.70).

⚡ Changing the photography mode exits multi-exposure mode without recording the images.

2

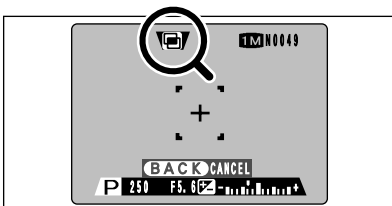

From the 2nd shot onwards, the yellow “*” icon appears on the screen.



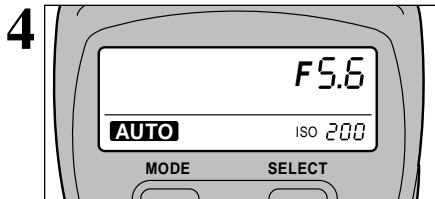

External Flash Settings

For external flash, refer to the user's manual for the flash and specify the settings as described below.

- Select External Flash mode (TTL mode cannot be used).
- Match the settings to the camera aperture setting. In "B • M" mode, match the settings to the aperture measured by the camera.
- Match the sensitivity setting (⇒P.51) to the setting on the camera.

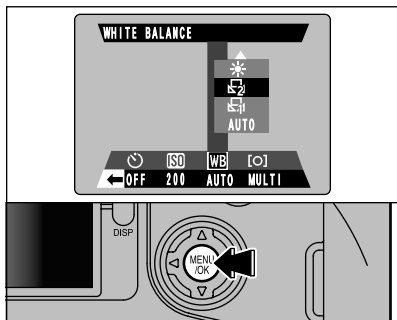

When the White Balance is Incorrect

Adjust the white balance to match the external flash.

In "a" in the Photography menu (⇒P.52), select ") • _ " Custom White Balance.

Press the "MENU/OK" button.

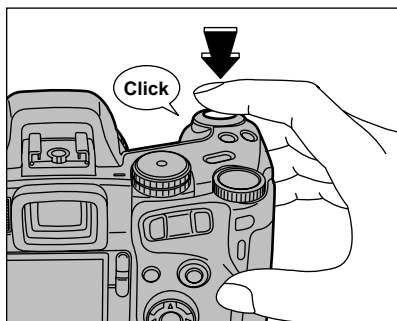

Hold a sheet of white paper so that it fills the entire screen.

When you press the shutter button, the flash fires and the white balance is set.

- After you take the picture, you should check the "Color (White Balance)" setting for the image.
 - Set the photography screen display to "PREVIEW" in the SET-UP screen (⇒P.70).
 - Set Power switch to "Q" (⇒P.18).

PHOTOGRAPHY MENU

r VOICE MEMO

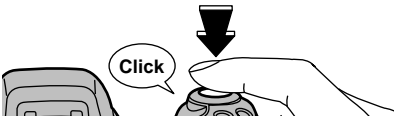
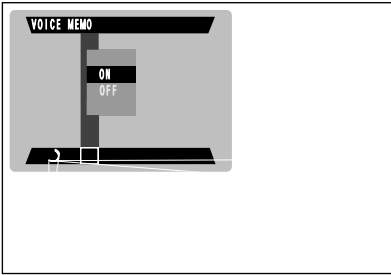

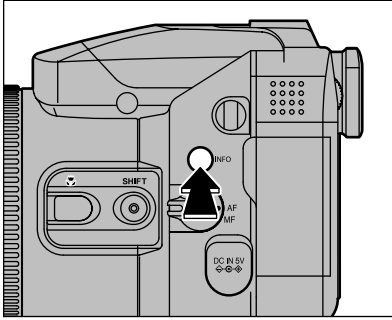

This function allows you to check the photography information. Hold down the "INFO" button to check the information.

⚡ This function cannot be used during multi-frame playback (➡P.27).

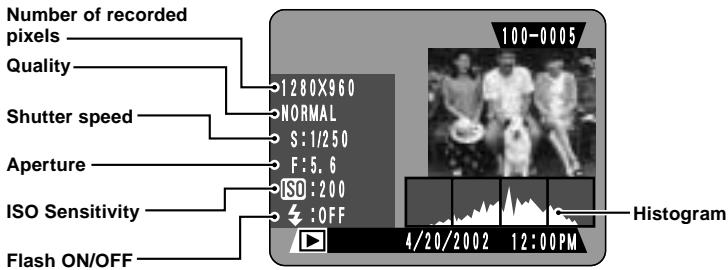

◆ Histograms ◆

A histogram is a chart showing the distribution of brightness in an image (horizontal axis: brightness; vertical axis: pixels).

- ① **Optimal exposure:** There is an ample distribution of pixels overall with a peak in the middle range.
- ② **Overexposed** : The number of highlight pixels is high with the distribution sloping upwards to the right.
- ③ **Underexposed** : The number of shadow pixels is high with the distribution sloping upwards to the left.



⚡ The shape of the graph will vary depending on the subject.

PLAYING BACK MOVIES

1

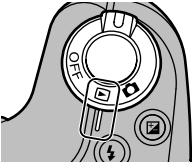

- ① Set Power switch to "Q".
- ② Use "◀" or "▶" to select the movie file.

- ⚠ Movies cannot be played back using multi-frame playback. Use the "DISP" button to select single-frame playback.

Indicated by the "u" icon.

2

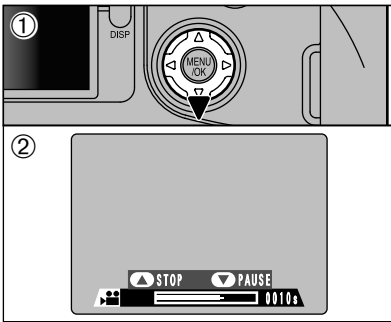

- ① Press "▼" to play the movie.
- ② The playback time is displayed on the screen along with a progress bar.

- ⚠ Take care not to block the speaker.
- ⚠ If the sound is difficult to hear, adjust the volume (→P.21).
- ⚠ If the subject of the movie is very bright, white streaks may appear on the image during playback. This is normal and is not a fault.

■ Playing Back Movies

	Control	Description
Playback		The movie automatically stops when playback ends.
Pause/Resume		Pauses the movie during playback. Press this button again to resume playback.
Stop		Stops playback. * Press "◀" or "▶" while movie playback is stopped to go back to the previous file or advance to the next file respectively.
Fast forward/ Rewind	 Rewind Fast forward	Press these during playback to skip forwards or backwards through the movie.
Skip playback	 When paused	<ul style="list-style-type: none"> • Each time you press "◀" or "▶" when the movie is paused, the movie advances or goes back one frame. • Hold down the button to move through the frames quickly.

* Refer to the Software Quick Start Guide (provided) for information on playing back movies on your PC.

◆ Compatible Movie Files ◆

PLAYING BACK VOICE MEMOS

- ① Set Power switch to “Q”.
- ② Use “◀” or “▶” to select an image file that has a voice memo.

- ⚠ You cannot play back voice memos using multi-frame playback. Use the “DISP” button to select single-frame playback.

The “r” icon is displayed.

2

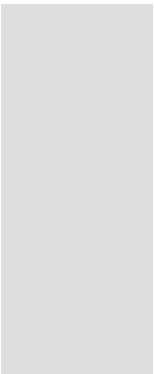
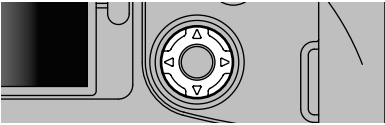

◆ Compatible Voice Memo Files ◆

PLAYBACK MENU

P ERASING SINGLE FRAME • ALL FRAMES/FORMATTING



Use “◀▶” to select “P ERASE”.

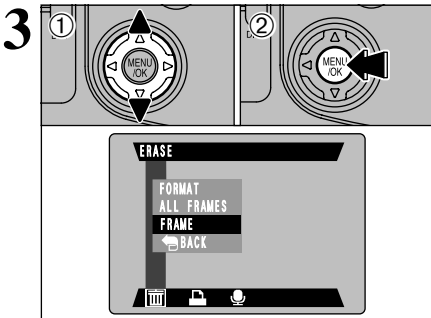

- ① Use “▲▼” to select “FRAME”, “ALL FRAMES” or “FORMAT”.
- ② Press the “MENU/OK” button.

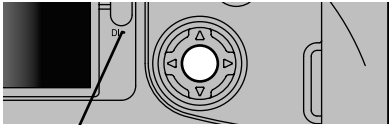

3

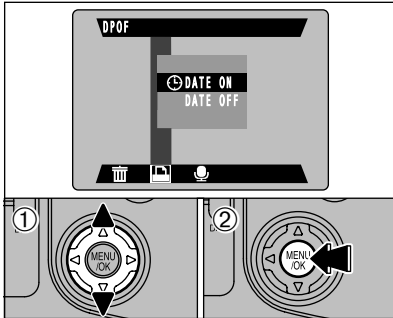

- ① Use “▲” and “▼” to select “DATE ON” or “DATE OFF”.
 - ② Press the “MENU/OK” button.
- The selected setting is then valid for all frames with DPOF settings.

4

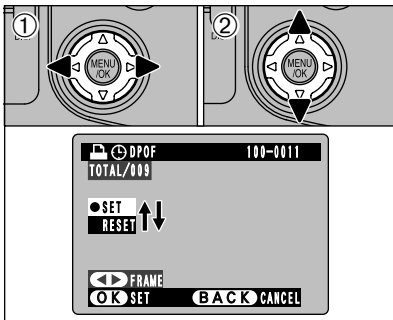

- ① Use “◀” or “▶” to display the frame for which you want to specify DPOF settings.
 - ② Use “▲” or “▼” to select the setting for the frame to be printed.
- To specify more DPOF settings, repeat steps ① and ②.
- Do not press the “MENU/OK” button until you have finished specifying all the DPOF settings for your images.

- ⚠ Prints cannot be ordered for movies (video).
- ⚠ “TOTAL” shows the total number of frames for which prints have been ordered.

5

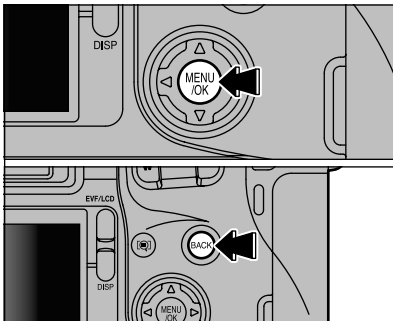

When you have finished specifying the DPOF settings, always press the “MENU/OK” button to confirm the settings.

If you press the “BACK” button, no DPOF settings are specified.

- ⚠ The number of prints that can be specified is one per each frame.
- Also, the maximum number of frames for which DPOF settings can be specified on the same media is 999.

Pressing the “MENU/OK” button confirms all the settings.

◆ DPOF Settings Cannot be Modified ◆



If you select a frame for which DPOF settings have already been specified, the “ ” message appears.

Pressing the “MENU/OK” button erases all the DPOF settings already specified. You must then specify the DPOF settings again.

- ⚠ Press the “BACK” button to leave the previous settings unchanged.
- ⚠ During playback, check that the “1” icon is displayed for the previous settings.

4

Advanced Features Playback

PLAYBACK MENU

r VOICE MEMO (RECORDING)

1

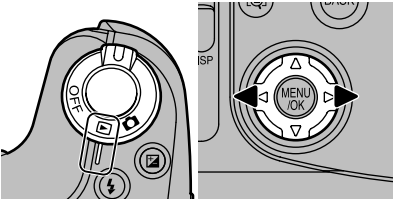

You can add voice memos to still images.

- ① Set Power switch to "Q".
- ② Use "◀" and "▶" to select the image (still image) to which you want to add a voice memo.

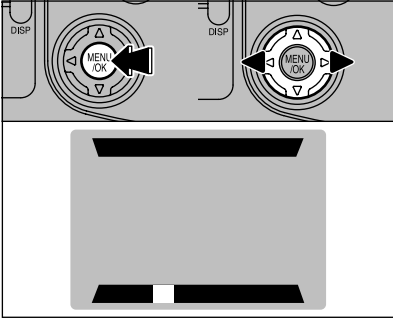

- ① Press the "MENU/OK" button to display the menu screen.
- ② Use "◀▶" to select "r VOICE MEMO".
- ③ Press the "MENU/OK" button.

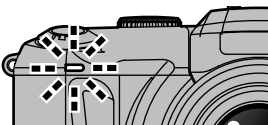
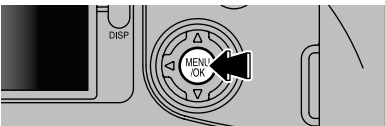

5

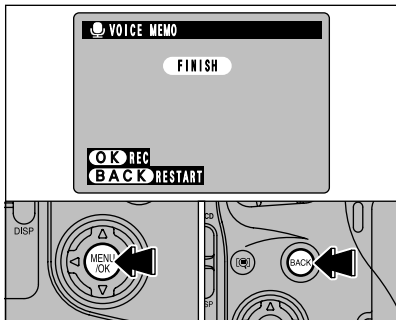

After 30 seconds of recording, "FINISH" appears on the screen.

To finish: Press the "MENU/OK" button.

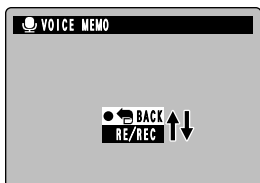

To re-record your comment: Press the "BACK" button.

◆ When the Image Already Has a Voice Memo ◆



If you select an image that already has a voice memo, a screen appears in which you can select whether or not to rerecord the memo.

■ SET-UP Menu Options

Settings	Display	Factory default	Explanation
q QUALITY	: SET	1 NORMAL	Allows you to set the number of recorded pixels and quality (compression ratio) settings for recorded images when pictures are taken. See P.69 for details.
u QUALITY	: SET	4	Allows you to set the number of recorded pixels setting for recorded images when movies are shot. See P.69 for details.
IMAGE DISPLAY	OFF/POSTVIEW/ PREVIEW	OFF	Use this option to specify whether the Preview screen (the photographed image) is displayed after you take a shot. See P.70 for details.
AF MODE	AF/AF AREA	AF	Allows you to set the auto focus method. See P.71 for details.
SET ADAPTER RING	YES/NO	NO	Select this setting when a conversion lens is used. See P.72 for details.
AUTO POWER OFF	2MIN/5MIN/OFF	2MIN	Use this option to specify whether the camera's power consumption is reduced and the camera is subsequently switched off automatically when it is not being used. See P.73 for details.
USB MODE	DSC/PC CAM	DSC	See P.75 for details.
SOUND F	LOW/HIGH/OFF	LOW	Allows you to set the volume of the beep emitted when the camera controls are used.
PRIMARY MEDIA	 (SMART MEDIA)  (MICRODRIVE)		Sets the media to be used when a SmartMedia and Microdrive are loaded in the camera.
DATE/TIME	: SET	-	Use this option to correct the date or time. See P.16 for details.
LANGUAGE	ENGLISH/FRANCAIS/ DEUTSCH	ENGLISH	Select English, French or German as the language used for screen display.
RESET ALL	: OK	-	With the exception of the date/time, custom white balance and EVF/LCD settings, this option resets all the camera settings to the factory default values set at shipment. Press "▶" to check the settings. If you are happy with the settings shown, press the "MENU/OK" button again.

- ① Set Power switch to "q".
- ② Set the Mode dial to "~" to display the SET-UP menu.

- ⚠ Always switch the camera off when you replace the batteries. If you open the battery cover or disconnect the AC power adapter without switching the camera off, the camera settings may revert to the factory default settings set at shipment.

q NUMBER OF RECORDED PIXELS

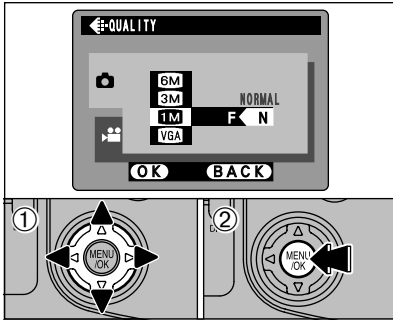

- ① Use “▲▼” to change the number of recorded pixels setting and “◀▶” to change the quality setting.
- ② Press the “MENU/OK” button to confirm your selection.

◆ Still Image Number of Recorded Pixels Settings ◆

You can select any combination of 4 image sizes and 4 quality settings. Try using the settings in the table below as a guide to achieving the desired results.

Select “HI” or “FINE” for better image quality and “BASIC” to fit more shots on the media. Normally, the “NORMAL” setting provides more than adequate image quality.

Number of recorded pixels	Quality	HIGH	FINE	NORMAL	BASIC
	3 (2832 × 2128)		①	①	①
2 (2048 × 1536)		—	②	②	—
1 (1280 × 960)		—	③	③	—
4 (640 × 480)		—	—	④	—

- ①: For printing at A4 (letter) size or for printing a trimmed image at A5 (6" × 8") / A6 (4" × 6") size
- ②: For printing at A5 (6" × 8") size or for printing a trimmed image at A6 (4" × 6") size
- ③: For printing at A6 (4" × 6") size
- ④: For use on the Internet as E-mail attachments, etc.

u NUMBER OF RECORDED PIXELS

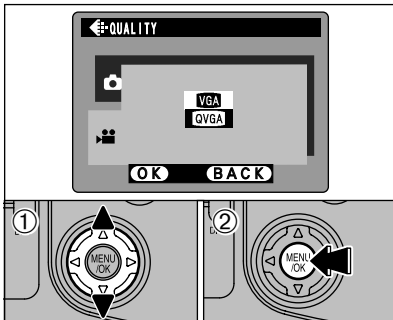

- ① Use “▲▼” to change the number of recorded pixels setting.
- ② Press the “MENU/OK” button to confirm your selection.

◆ Movie Settings ◆

You can choose either of 2 number of recorded pixels (image sizes). Select “VGA” for better image quality or “QVGA” for longer shooting times.

	Number of Recorded Pixels
4	640 × 480 pixels
5	320 × 240 pixels

SET-UP

DISPLAYING PHOTOGRAPHED IMAGES

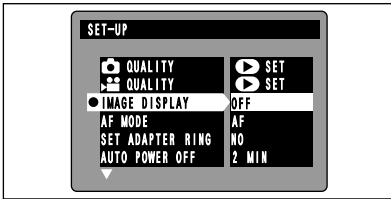

You can use this setting to specify whether photographed images are displayed after shooting.

In top5-frame continuous shooting, final5-frame continuous shooting and auto bracketing, the images are displayed for a set time before being automatically recorded even when "OFF" is selected here.

- OFF** : Photographed images are automatically recorded without being displayed.
- POSTVIEW**: Photographed images are displayed for approx. 2 seconds and then automatically recorded.
- PREVIEW** : Photographed images are displayed and you can then select whether to record the images.
- To record the image: Press the "MENU/OK" button.
 - To discard the image: Press the "BACK" button.
- You can also use the preview zoom or select recorded images.

When previewing is selected, this feature allows you to check the image details.

- ① Press the zoom button to zoom in or out.
- ② Use "▲▼◀▶" to view another part of the image.

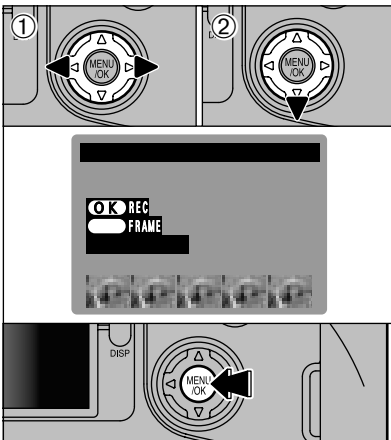

When previewing is selected, you can select and record images shot using top5-frame continuous shooting, final5-frame continuous shooting or auto bracketing. However, you cannot use the preview zoom.

- ① Press "◀▶" to select an image you do not want to record.
- ② Press "▼" to display or hide the "p" icon. Images with the "p" icon are not recorded. Display the "p" icon for all the images you do not want to record.
- ③ Press the "MENU/OK" button to record the desired images.

AF MODE

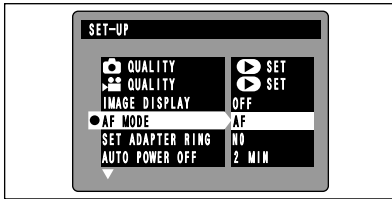

Use this setting to specify the focusing method.

AF mode : Focuses on the center of the screen.



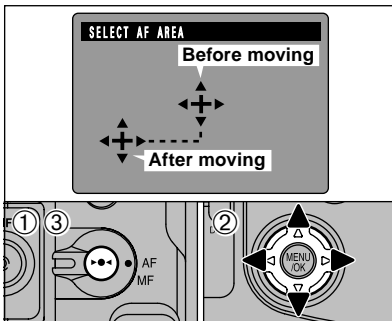

AF AREA mode: Allows you to change the location on the screen where the shot will be focused. Use this feature in situations such as tripod shots where you have composed the shot and want to change the focusing location.

 The focus checking function cannot be used when AF AREA is selected.

1



AF AREA

Hold down the “ ” button ① and press “” to move the “?” (target point) ② to the desired focusing position.

③ Release the “ ” button.

2

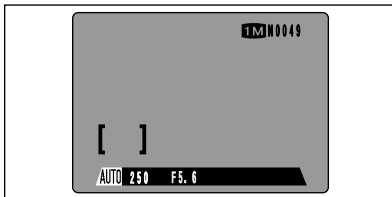

The AF frame is displayed in the location to which the target point was moved.

Press the shutter button down halfway and take the shot normally.

To reposition the AF frame, repeat step 1.

Regardless of the AF frame location, the exposure is always set using the area in the center of the screen. To expose the shot for your main subject, use AE lock.

SET-UP

SET ADAPTER RING

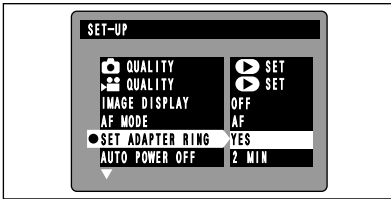

YES: Select this setting when you are using a conversion lens. When you select this setting, the “; ” icon is displayed.

NO : Select this setting when you are not using a conversion lens.

⚠ Selecting the wrong setting could prevent the camera from focusing successfully.

◆ Overview of the Conversion Lens/Adapter Ring ◆

Wide Conversion Lens WL-FX9

This is a set that includes a wide conversion lens and adapter ring and converts the camera's focal length by 0.79× (equivalent to a 28 mm wide-angle lens). This set also allows you to use commercially available filters.

● Wide conversion lens specifications

- Magnification : 0.79×
- Lens configuration: 3 lenses in 3 groups
- Dimensions : 32 mm (1.26 in.) × 70 mm (2.76 in.) dia.
- Mass (Weight) : Approx. 185 g (6.5 oz.)
- Accessories : Adapter Ring AR-FX9 (see below for specifications), Lens caps (front and rear), Lens pouch

⚠ This lens should be used at the wide-angle zoom setting (equivalent to 28 mm-46 mm). Using the lens at the telephoto setting increases the amount of distortion.

⚠ The wide conversion lens and built-in flash cannot be used together.

Teleconversion Lens TL-FX9

This accessory increases the focal length of your lens by 1.5× without changing its F-stop value.

● Teleconversion lens specifications

- Magnification : 1.5×
- Lens configuration: 3 lenses in 3 groups
- Dimensions : 55 mm (2.17 in.) × 65 mm (2.56 in.) dia.
- Mass (Weight) : Approx. 100 g (3.5 oz.)
- Accessories : Adapter Ring AR-FX9 (see below for specifications), Lens caps (front and rear), Lens pouch

⚠ The TL-FX9 should only be used for telephoto-angle shots where eclipsing does not occur. Eclipsing occurs at wide-angle settings.

⚠ The built-in flash cannot be used with the teleconversion lens.

Adapter Ring AR-FX9

The adapter ring is required for using commercially available filters.

● Adapter ring specifications

- Compatible filters : 55 mm-diameter commercial available filters
- Dimensions : 39 mm (1.54 in.) × 58 mm (2.28 in.) dia.
- Mass (Weight) : Approx. 30 g (1.1 oz.)

⚠ Do not use more than one filter at a time.

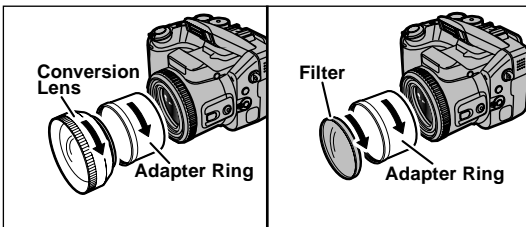

Mount the Adapter Ring, Conversion Lens and commercially available filters by screwing them on in the direction of the arrow.

AUTO POWER OFF SETTING

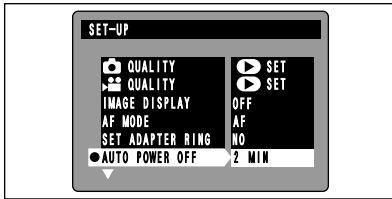

When this function is enabled, the screen temporarily switches off (sleeps) to save power if the camera is not used for approx. 30 seconds. If the camera remains unused for an additional interval (2 minutes or 5 minutes), it is automatically switched off. Use this function when you want to get the maximum possible running time from your batteries.

⚠ Auto Power Off is disabled when the camera is connected via the USB connection.

Sleep does not function in set-up or playback mode, but the camera automatically switches off if the camera is not used for a set time (2 minutes or 5 minutes).

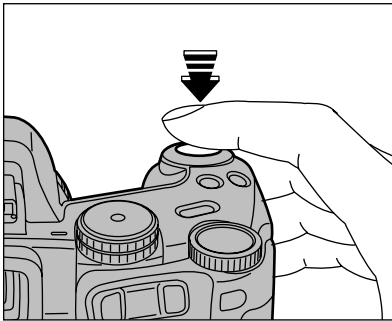

When the camera is in sleep mode, pressing the shutter button down halfway wakes the camera up so that it is ready to take pictures. This is a useful feature as it allows you to take pictures more quickly than switching the camera off and then on again.

⚠ You can wake the camera up by pressing any other button as well as the shutter button.

◆ Switching the Camera Back On ◆

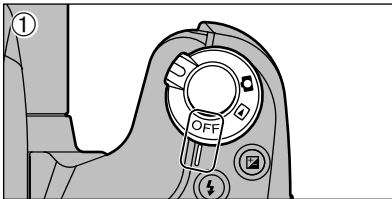

① Set the Power switch to OFF.

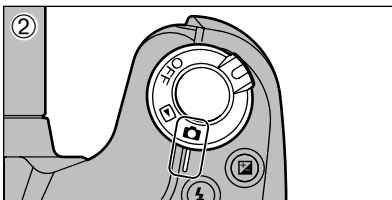

② Set the Power switch to "Q" or "Q".

Connecting to a TV

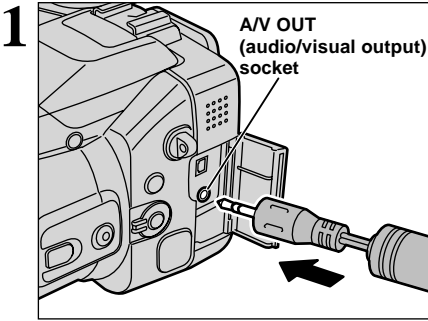

Switch off the camera and TV. Open the terminal cover and plug the A/V cable (provided with the camera) into the "A/V OUT" (audio/video output) socket.

⚠ If there is a power outlet available, connect the AC-5VHS/AC-5VH AC Power Adapter.

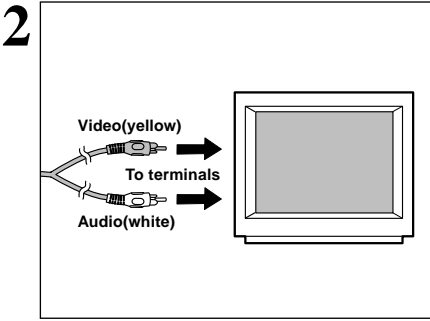

Plug the other end of the cable into the video input socket on the TV. Then switch the camera and TV on and take pictures or play back images as you would normally.

⚠ Refer to the instructions provided with your TV for more information on video input for your TV.

Using the AC Power Adapter (OPTIONAL)

The AC Power Adapter AC-5V is useful since it allows you to take pictures, play back images (connected to a TV, etc.) and connect to a computer without worrying about using up the battery charge.

● Compatible AC power adapters

Model: AC-5VH/AC-5VHS (sold separately)

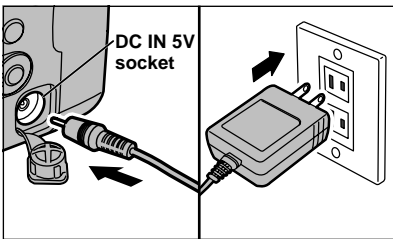

Check that the camera is switched off. Open the terminal cover and plug the AC power adapter connector into the "DC IN 5V" socket. Then plug the AC power adapter into a power outlet.

⚠ Problems arising through the use of products other than genuine FUJIFILM products are not covered by your warranty.

⚠ See P.82 for notes on using the AC power adapter.

⚠ Install the equipment near a socket outlet for easy accessibility.

⚠ The shapes of the AC power adapter, the plug and socket-outlet depend on the country.

Connecting the AC power adapter does not allow you to charge the Ni-MH batteries. Use the optional battery charger (→P.80) to charge the Ni-MH batteries.

CONNECTING TO A COMPUTER

This section gives an overview of the functions that can be used with a USB connection and describes the connection method. Refer also to the Software Quick Start Guide booklet. **Refer to the Software Quick Start Guide booklet for details.**

The first time you connect the camera to your computer

You must install all the software before connecting the camera to your computer. Refer also to the Software Quick Start Guide booklet.



CD-ROM
(Software for FinePix EX)

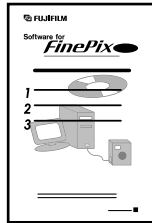

Software Quick Start Guide

DSC (Mass storage device) Mode

This mode provides a simple way to read images from a media and store images on to a media (⇒P.76).

PC-CAM (camera) Mode

This function allows you to conduct videoconferencing sessions between PCs connected to the Internet. This function can also be used to record video on a PC (⇒P.77).

- **Videoconferencing (“PictureHello”) is not supported on Macintosh computers.**
- The PC Camera function cannot be used on Mac OS X (including the Classic environment). Use a Mac OS version between 8.6 and 9.2.

Shows you new ways of using FinePixViewer. You will need Acrobat Reader to select this menu option.

Use this option to download the latest version of FinePixViewer.

FinePix CD Album Maker
Helps you to organize your images and record them onto CD-R disks.

FinePixViewer provides a host of convenient menu options, including batch operations.

You can check the image details and perform simple image processing (rotate, add caption, crop, etc.).

Use this area to check and compare the photography settings.

CONNECTING AT DSC MODE

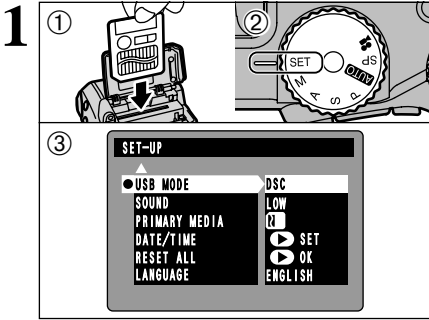

- ① Load the media containing your shots into the camera.
- ② Set the Mode dial to “~” and then set the Power switch to “q”.
- ③ Select “DSC” in “USB MODE” in the SET-UP menu (⇒P.68) and then switch the camera off.

⚡ It is recommended that you connect the AC Power Adapter AC-5VH/AC-5VHS (sold separately) (⇒P.74). Constant power supply will prevent successful data transfer from trouble caused by power supply.

⚡ If you load a SmartMedia and a Microdrive into the camera at the same time, images will be recorded onto the media selected as the “Priority media” (⇒P.68).

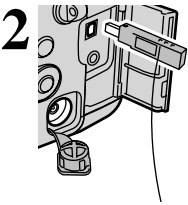

- ① Switch your PC on.
- ② Connect the special USB cable to the camera and the computer.
- ③ Switch the camera on.

Always use the prescribed procedure when disconnecting or switching off the camera (⇒P.78).

If you are using a Windows PC, the driver settings are specified automatically when installation is completed. No further action is required.

* If your PC fails to recognize the camera, refer to the Software Quick Start Guide.

⚡ On Windows XP and Mac OS X, automatic launch settings must be specified the first time you connect the camera to your computer (⇒Software Quick Start Guide booklet).

⚡ Ensure that you plug each end of the special USB cable into the correct socket and that the plugs are firmly inserted all the way into the connection sockets.

CONNECTING AT PC CAMERA MODE

- ① Set the Mode dial to “SET”.
- ② Set the Power switch to “q”.
- ③ Select “PC CAM” in “USB MODE” in the SET-UP menu (➔P.68) and then switch the camera off.

⚠ It is recommended that you connect the AC Power Adapter AC-5VH/AC-5VHS (sold separately) (➔P.74). Constant power supply will prevent successful date transfer from only trouble caused by power supply.

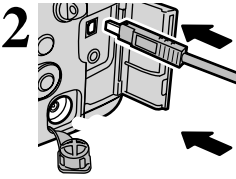

- ① Switch your PC on.
- ② Connect the special USB cable to the camera and the computer.
- ③ Switch the camera on.

If you are using a Windows PC, the driver settings are automatically specified when installation ends. Simply wait a few moments.

* If your computer does not recognize the camera, refer to the Software Quick Start Guide.

⚠ Ensure that you plug each end of the special USB cable into the correct socket and that the plugs are firmly inserted all the way into the connection sockets.

DISCONNECTING FROM THE PC (Important — always use this procedure.)

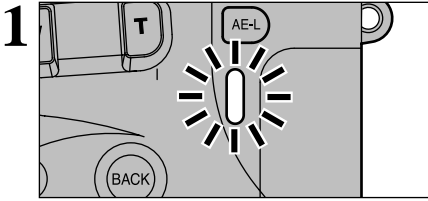

- 1 Quit all applications (FinePixViewer, Videolmpression, etc.) that are using the camera.
- 2 Check that the indicator lamp is lit green (the camera is not exchanging data with the computer).

For a DSC connection, proceed to step 2. For a PC CAMERA connection, proceed to step 3.

In some cases, the camera and computer may still be communicating even after the "Copying" message disappears from the computer screen. Always check that the indicator lamp is lit green.

- 2 Perform the steps shown below before you switch the camera off. This procedure differs depending on the operating system software (or PC) you are using.

Windows 98/98 SE

No PC operation is required. Go ahead to step 3.

Windows Me/2000 Professional/XP

- 1 Right-click the removable disk icon in the "My Computer" window and select Eject.
- 2 Left-click the Eject icon in the taskbar and eject "USB Disk".



* This step is only required in Windows Me.



* Windows Me screen

- 3 The menu option shown below appears. Click on this option.



* Windows Me screen

- 4 The "Eject hardware" dialog box appears. Click the [OK] button or the close button.

Macintosh

Drag the "Removable drive" icon on the desktop to the Trash.



- 4 When you drag the icon to the Trash, "REMOVE OK" appears on the camera's screen.

- 3 Switch the camera off and disconnect the special USB cable.

System Expansion Options

► By using the FinePix S602 ZOOM together with other optional FUJIFILM products, your system can be expanded to fill a wide range of uses.

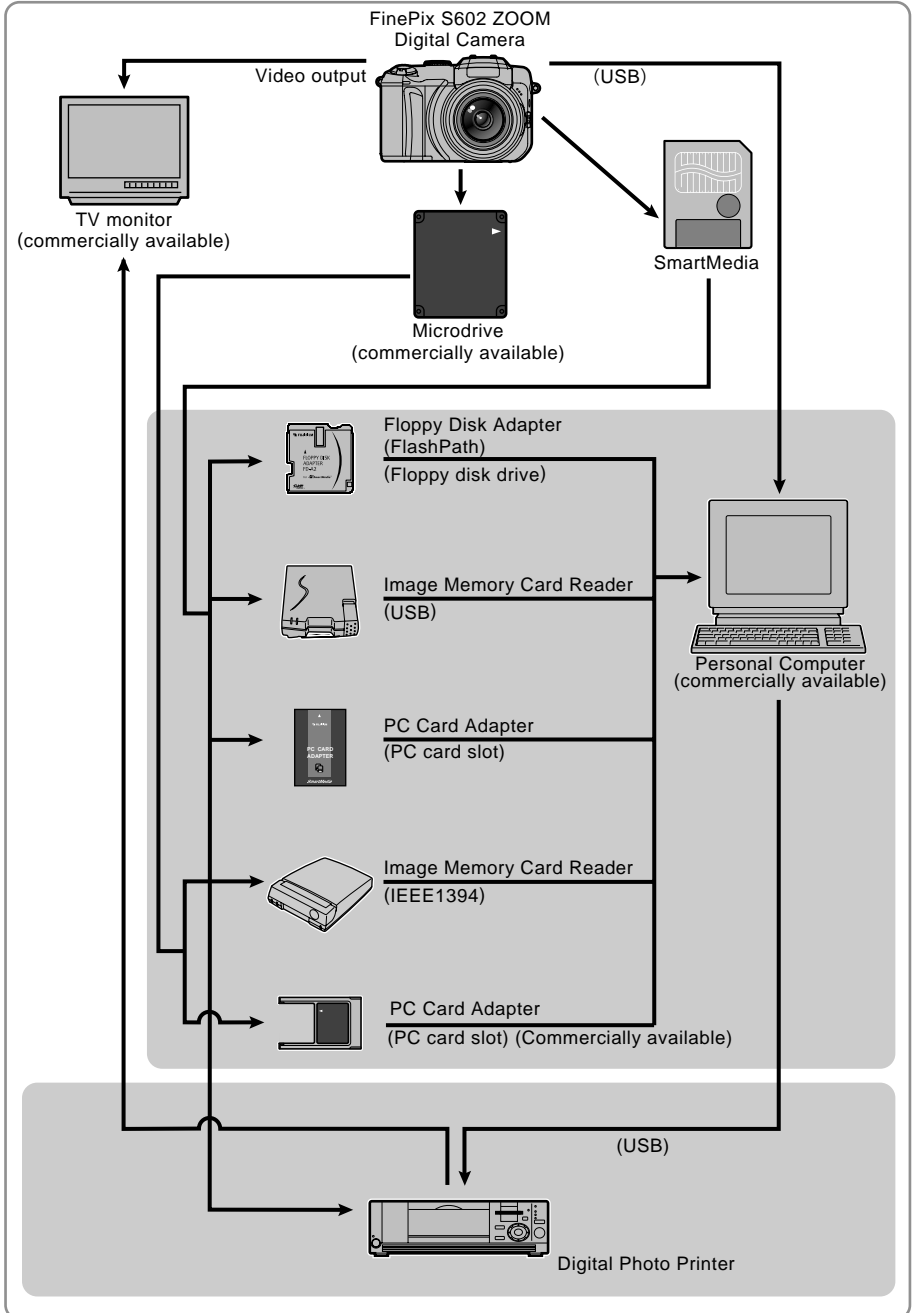

Accessories Guide

► The optional accessories (sold separately) can make taking pictures with the FinePix S602 ZOOM even easier. For information on how to attach and use the accessories, refer to the instructions provided with the accessory used.

Visit the FUJIFILM web site for the latest information on camera accessories. <http://home.fujifilm.com/products/digital/index.html>

● SmartMedia™

These are SmartMedia cards sold separately. Use the 9 types listed below.

● MG-4S : 4MB, 3.3V ● MG-8S : 8MB, 3.3V ● MG-16S : 16MB, 3.3V

● MG-32S : 32MB, 3.3V ● MG-64S : 64MB, 3.3V

* Some 3.3V SmartMedia are labelled as "3V" cards.

● MG-16SW : 16MB, 3.3V, ID ● MG-32SW : 32MB, 3.3V, ID

● MG-64SW : 64MB, 3.3V, ID ● MG-128SW : 128MB, 3.3V, ID

* SmartMedia with ID are labelled as "ID" cards.

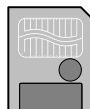

● AC-5VH/AC-5VHS AC Power Adapter

Use the AC-5VH/AC-5VHS when you want to take pictures or play back images for long periods or when the FinePix S602 ZOOM is connected to a personal computer.

* The shape of the AC power adapter, the plug and socket outlet depend on the country.

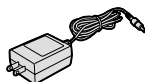

● Fujifilm Rechargeable Battery 2HR-3UF

The 2HR-3UF includes 2 pieces of high-capacity AA-size Nickel Metal Hydride batteries.



● Fujifilm Battery Charger with Battery BK-NH (Not Available in U.S.A. / Canada)

The BK-NH includes the quick battery charger BCH-NH and 2 AA Ni-MH batteries.

The BCH-NH can charge 4 AA Ni-MH batteries in approx. 180 minutes.

Up to 4 Ni-MH or Ni-Cd batteries can be charged simultaneously.

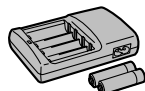

● FD-A2 Floppy Disk Adapter (FlashPath)

This adapter is the same size and shape as a 3.5-inch floppy disk. You can copy the images on a SmartMedia to your PC simply by loading the SmartMedia into the floppy disk adapter and then inserting the adapter into your floppy disk drive.

	Compatible OS	Compatible SmartMedia
FD-A2	Windows 95/98/98 SE/Me/NT4.0 Mac OS 7.6.1 to 9.1	5V/3.3V, 2MB to 128MB



● SM-R2 Image Memory Card Reader

The SM-R2 allows images to very easily be read and written from an image memory card (SmartMedia) to a personal computer. Its USB interface provides high-speed data transmission.

● Compatible with Windows 98/98 SE, Windows Me, Windows 2000 Professional or iMac or Power Macintosh and models that support USB as standard.

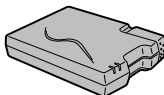

● DM-R1 Image Memory Card Reader

This device provides a simple way to transfer image data in either direction between your PC and an image memory card (SmartMedia or CompactFlash Type II (Microdrive-compatible)).

The IEEE 1394 interface provides high-speed data transfer.

● Compatible with Windows 98 SE, Windows 2000 Professional (read-only), iMac DV and Power Macintosh PCs with FireWire as a standard feature. Mac OS 8.5.1 to 9.1



● PC-AD3 PC Card Adapter

The PC Card Adapter allows the SmartMedia to be used as a PC Card Standard ATA-compliant (PCMCIA 2.1) PC card (Type II).

● Compatible with SmartMedia of 5V/3.3V, 2MB to 128MB.



● SC-FX602 Soft Case

This is a special case made of polyester that protects the camera against soiling, dust and minor impacts when it is being carried.

Notes on Using Your Camera Correctly

► Be sure to read this information in conjunction with “Safety Notes” (⇒P.90), to ensure that you use your camera correctly.

■ Places to Avoid

Do not store or use the camera in the following types of locations:

- In the rain or in very humid, dirty or dusty places.
- In direct sunlight or in places subject to extreme temperature rises, such as in a closed car in summer.
- Extremely cold places.
- Places subject to strong vibration.
- Places affected by smoke or steam.
- Places subject to strong magnetic fields (such as near motors, transformers or magnets).
- In contact with chemicals such as pesticides or next to rubber or vinyl products for long periods of time.

■ Notes on Immersion in Water or Sand

The FinePix S602 ZOOM is particularly adversely affected by water and sand. When you are at the beach or close to water, ensure that the camera is not exposed to water or sand. Take care also not to place the camera on a wet surface. Water or sand inside the camera can cause faults that may be irreparable.

■ Notes on Condensation

If the camera is carried suddenly from a cold location into a warm place, water droplets (condensation) may form on the inside of the camera or on the lens. When this occurs, switch the camera off and wait an hour before using the camera. Condensation may also form on the media. In this event, remove the media and wait a short time before using it again.

■ When the Camera is Unused for Long Periods

If you do not intend to use the camera for a long period of time, remove the battery and the media card before storing the camera.

■ Cleaning Your Camera

- Use a blower brush to brush away any dust on the lens, LCD monitor surface, viewfinder or external AF sensor and then gently wipe the camera with a soft, dry cloth. If any soiling remains, apply a small amount of lens cleaning liquid to a piece of FUJIFILM lens cleaning paper and wipe gently.
- Do not scratch hard objects against the lens, LCD monitor screen or viewfinder as these surfaces are easily damaged.
- Clean the body of the camera with a soft, dry cloth. Do not use volatile substances such as thinners, benzine or insecticide, as these may react with camera body and cause deformation or remove the coating.

■ Using the Camera Overseas

When travelling overseas, do not place your camera in the check-in baggage. Baggage handling at airports may subject baggage to violent shocks, and the camera may be damaged internally even when no external damage is visible.

Notes on the Power Supply

Applicable Batteries

- AA-size alkaline, Ni-MH (nickel-metal hydride) can be used with this camera.
Do not use AA-size manganese, lithium or nickel-cadmium (Ni-Cd) batteries in your FinePix S602 ZOOM because the heat generated by the batteries could damage the camera

Notes on the Batteries

Incorrect use of the batteries could cause them to leak, become hot, ignite or burst. Always observe the precautions given below.

- Do not heat the batteries or throw them into a fire.
- Do not carry or store the batteries with metal objects such as necklaces or hairpins that could come into contact with the metal positive and negative poles of the battery.
- Do not expose the batteries to fresh or sea water, and take particular care to keep the terminals dry.
- Do not attempt to deform, disassemble or modify the batteries.
- Do not attempt to peel off or cut the battery casing.
- Do not drop, strike or otherwise subject the batteries to strong impacts.
- Do not use the batteries that are leaking, deformed, discolored or exhibit any other obvious abnormality.
- Do not store the batteries in very warm or moist locations.
- Keep the batteries out of reach of infant and young children.
- When loading the batteries into the camera, ensure that the battery polarity (+ and -) is as indicated on the camera.
- Do not use new batteries together with used batteries. In the case of rechargeable batteries, do not use charged and discharged batteries together. Do not use batteries of different types or brands together.
- If you do not intend to use the camera for a long period of time, remove the batteries from the camera (Note that if the camera is left with the batteries removed, the time and date settings are cleared).
- The batteries may feel warm immediately after being used. Before removing the batteries, switch the camera off and wait until the batteries cool down.
- When replacing the batteries, always fit 4 new batteries. Here, 'new batteries' refers to either recently purchased unused alkaline batteries, or Ni-MH (nickel metal hydride) batteries that have recently been fully recharged together.
- In cold locations (at temperatures of +10°C/+50°F or below), battery performance deteriorates and the time for which they can be used shortens markedly. This is particularly true of alkaline batteries. In cold conditions, put the batteries in your pocket or a similar place to warm them before loading them into the camera. If you use a body warmer to warm the batteries, ensure that they are not in direct contact with the warmer.
- Soil (such as fingerprints) on the battery terminals can markedly reduce the number of available shots. Carefully wipe the battery terminals clean with a soft dry cloth before loading the batteries.

⚠ If any liquid at all leaks from the batteries, wipe the battery compartment thoroughly and then load new batteries.

⚠ If any battery fluid comes into contact with your hands or clothing, flush the area thoroughly with water. Note that battery fluid can cause loss of eyesight if it gets into your eyes. If this occurs, do not rub your eyes. Flush the fluid out with clean water and contact your physician for treatment.

Notes on Using the AC Power Adapter

Always use the AC-5VH/AC-5VHS AC Power Adapter with the camera.

The use of an AC Power adapter other than AC-5VH/AC-5VHS could result in damage to your digital camera.

- This AC power adapter is designed exclusively for indoor use.
- Plug the connection cord plug securely into the DC input terminal of the FUJIFILM Digital camera.
- Turn off the power switch of the FUJIFILM Digital camera before disconnecting the connection cord from the FUJIFILM Digital camera's DC input terminal. To disconnect, take hold of the plug and pull it out (do not disconnect it by pulling on the cord).

or cause malfunctions.

- The operating lives of alkaline batteries vary between brands and the life of batteries you purchase may be shorter than the alkaline batteries provided with the camera.

Disposing of Batteries

When disposing of batteries, do so in accordance with your local waste disposal regulations.

Notes on Small Rechargeable Batteries (Ni-MH batteries)

- Always use the special battery charger to charge AA-size Ni-MH batteries. Charge the batteries as described in the instructions provided with the battery charger.
- Do not use the battery charger to charge batteries other than those specified for use with the charger.
- Note that the batteries may feel warm immediately after being charged.
- Ni-MH batteries are not charged at shipment. Be sure to charge the batteries before using them.
- The camera mechanism is such that it draws a minute amount of current even when the camera is switched off. Take particular care not to leave Ni-MH batteries in the camera for a long period of time as they can become excessively discharged and may no longer be usable even when charged.
- Ni-MH batteries self-discharge even when not used. Always charge Ni-MH batteries before using them. If the time for which a battery provides power shortens markedly when it has been correctly charged, this indicates that the battery has reached the end of its effective life and should be replaced.
- Soiling (fingerprints, etc) on the terminals of Ni-MH batteries can greatly reduce the number of available shots. When this occurs, clean the terminals carefully with a soft dry cloth. Then use up the remaining charge in the batteries and recharge them.
- Newly purchased batteries or batteries that have been left unused for an extended period may not be fully charged. (This is indicated by the immediate display of the battery low warning or a low number of available shots.) This is a normal characteristic of the batteries and does not indicate a fault. Repeatedly charging and using the batteries 3 or 4 times will restore them to a normal condition.
- If you repeatedly charge a Ni-MH batteries before it is fully discharged, it will suffer from the "memory effect"*, causing the battery low warning to appear while there is still ample charge remaining in the battery. To restore the batteries to their normal condition, use up all the charge in the batteries before recharging them.

* Memory effect: A phenomenon affecting the battery characteristics such that the apparent battery capacity decreases.

- Do not use this AC power adapter with any device except the specified device.
- During use, this AC power adapter will become hot to touch, but this is normal.
- Do not disassemble the AC power adapter. Doing so could be dangerous.
- Do not use this device in a place with high temperature and high humidity.
- Do not drop or subject this device to strong shocks.
- This device may emit a humming noise, but this is normal.
- If used near a radio, this device may cause static, so play the radio in a distant place.

Notes on the Media (SmartMedia™ and Microdrives)

■ SmartMedia

The SmartMedia card is a new image recording medium developed especially for use in digital cameras. Each SmartMedia card contains a built-in semiconductor memory chip (NAND flash memory) which is used for storing image data files in digital form.

Because the data is stored electronically, the stored image data can be erased from the card and new data recorded.

■ SmartMedia with ID

A SmartMedia with ID is a SmartMedia that has an individually assigned identification number. SmartMedia ID cards can be used with devices that use ID numbers for copyright protection or other purposes. This camera accepts SmartMedia ID cards in the same way as conventional SmartMedia cards.

■ Microdrives

Microdrives are compact, lightweight hard disk drives that conform to the CF+ Type II standard. Due to their ample capacity for large image data files and their low per-megabyte recording cost, Microdrives provide a more economical way to save high-resolution image files.

■ Storing Data

In the situations listed below, recorded data may be erased (destroyed). Please note that FUJIFILM accepts no responsibility whatsoever for the loss (destruction) of recorded data.

- * When the media is used incorrectly by the owner or a third party
- * When the media is exposed to static electricity or electrical noise
- * When the media is removed or the camera is switched off during data recording or erasing (media formatting)
- * When the media is bent, dropped or otherwise subjected to a strong force or impact

Important data should be backed up onto another medium.
(MO disk, floppy disk, hard disk, etc.)

■ General Notes on Handling Media (all types)

- When inserting the media into the camera, hold the media straight as you push it in.
- Never remove the media or switch the camera off during data recording or erasing (media formatting) as this could result in damage to the media.
- Data storage media are precision electronic devices. Do not bend, drop or otherwise subject the media to strong force or shocks.
- Do not use or store these media in environments likely to be affected by strong static electricity or electrical noise.
- Do not use or store media in locations subject to high temperatures and humidity or in environments where they are exposed to corrosive substances.

■ Notes on Handling SmartMedia

- Use only the SmartMedia specified for use with the camera. The use of other SmartMedia could damage the camera.
- Take care not to touch the SmartMedia's contact area (the gold-colored area) or allow the area to become soiled. Use a soft, dry cloth to wipe off any soiling that does occur.
- To avoid damage caused by static electricity, always use the special static-free case provided when carrying or storing the media. Alternatively, keep the SmartMedia in a storage case if available.
- Inserting a SmartMedia that is charged with static electricity into your camera may result in a camera malfunction. If this occurs, switch the camera off and then on again.
- Do not carry SmartMedia in locations such as a trouser pocket. This could subject the SmartMedia to excessive force when you sit down, thereby damaging the

SmartMedia.

- The SmartMedia may feel warm when it is removed from the camera after extended periods of use. This is normal and does not indicate a fault.
- SmartMedia have a limited life and it may become impossible to record or erase data on a SmartMedia that has been used for a long time. When this happens, purchase a new SmartMedia.
- Affix the index labels supplied with the SmartMedia onto the designated area of the card. Do not use third-party labels as this can lead to problems when the card is inserted or removed.
- When you attach the index label to a SmartMedia, take care that it does not cover any part of the write-protect area.

■ Notes on using Microdrive

- Do not write on the Microdrive label.
- Do not peel off the Microdrive label.
- Do not stick additional labels onto a Microdrive.
- When carrying or storing a Microdrive, keep it in the protective case provided.
- Do not use Microdrive in CF+ Type II slots that do not have an eject function.
- Take care when handling Microdrive that have been used for long periods as they may become hot.
- Do not place Microdrive close to strong magnetic fields.
- Keep Microdrive dry.
- Do not apply strong pressure to the Microdrive cover.

■ Notes on using media with a computer







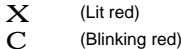
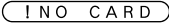

- If you intend to take photos using a media that has been used on a personal computer, first format the media on your camera.
- When you format a media in the camera and then photograph and record images, a folder is automatically created on the media. Image data is then recorded in this folder.
- Do not change or delete the folder names or file names on the media from your computer as this will make it impossible to use the media in your camera.
- Always use the camera to erase image data on a media.
- To edit image data, copy the image data to the computer's hard disk and then edit the copied data.

■ SmartMedia Specifications

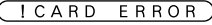
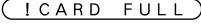
Type	Image memory card for digital cameras (SmartMedia)
Operating voltage	3.3V
Conditions for use	Temperature: 0°C to +40°C (+32°F to +104°F) Humidity: 80% or less (no condensation)
Dimensions	37 mm × 45 mm × 0.76 mm (1.45 in. × 1.77 in. × 0.03 in.) (W × H × D)

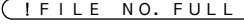
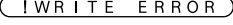
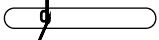
Warning Displays

▶ The table below lists the warnings that are displayed on the LCD monitor

Warning Displayed	Explanation	Remedy
	The camera batteries are low on charge.	Have spare batteries ready or replace the batteries.
	No media is inserted.	<ul style="list-style-type: none"> • Load a SmartMedia (3.3V) in the correct direction. • Load a Microdrive in the correct direction.
	<ul style="list-style-type: none"> • The media is not formatted (initialized). • The SmartMedia contact area (gold-colored area) is dirty. • The camera is faulty. 	<ul style="list-style-type: none"> • Format the media. • Wipe the SmartMedia contact area with a soft, dry cloth. It may also be necessary to format the SmartMedia. If an error message still appears, replace the SmartMedia. • Contact your FUJIFILM dealer.
	<ul style="list-style-type: none"> • The SmartMedia is not loaded correctly. • The SmartMedia contact area (gold-colored area) is dirty. • The media is damaged. • The media format is incorrect. • The camera is faulty. 	<ul style="list-style-type: none"> • Push the SmartMedia all the way into the slot and check that it is locked into place. • Wipe the SmartMedia contact area with a soft, dry cloth. It may also be necessary to format the SmartMedia. If an error message still appears, replace the SmartMedia. • Contact your FUJIFILM dealer.
	The media is full and no further data can be recorded.	Erase some images or use a media that has some available space.
	The SmartMedia is write-protected.	Use a SmartMedia that is not write-protected.
	<ul style="list-style-type: none"> • You attempted to play back file that was not recorded correctly. • The SmartMedia contact area (gold-colored area) is dirty. • The camera is faulty. • You attempted to play back a voice file that was recorded on a FinePix 50i. 	<ul style="list-style-type: none"> • That data cannot be played back. • Wipe the SmartMedia contact area with a soft, dry cloth. It may also be necessary to format the SmartMedia. If an error message still appears, replace the SmartMedia. • Contact your FUJIFILM dealer. • That data cannot be played back.
	Frame number 999-9999 has been reached.	Use a formatted SmartMedia to take pictures.
	<ul style="list-style-type: none"> • Data cannot be recorded due to a media fault or a problem with the connection between the media and the camera. • The image you just shot is too large to fit in the space available on the media. 	<ul style="list-style-type: none"> • Reload the media or switch the camera off and then on again. If this does not remedy the problem, contact your FUJIFILM dealer. • Use a new media.
	<ul style="list-style-type: none"> • The voice memo file is faulty. • The camera is faulty. 	<ul style="list-style-type: none"> • The voice memo cannot be played back. • Contact your FUJIFILM dealer.
	There is a strong likelihood of camera shake because the shutter speed is slow.	Use flash photography. However, a tripod should be used for some scenes and modes.
	You attempted to erase a protected frame.	Protected frames cannot be erased. Remove the protection using the camera on which the protection was applied.
	The AF (auto focus) doesn't work very well.	<ul style="list-style-type: none"> • If the subject is too dark, take the shot at a distance of roughly 2 meters from the subject. • Use AF lock to take the picture.

Warning Displayed	Explanation	Remedy
DPOF SPECIFIED. ERASE OK?	You attempted to erase an image for which DPOF settings have been specified.	Erasing the image deletes the setting from the DPOF specifications at the same time.
DPOF SPECIFIED. ERASE ALL OK?		
RESET DPOF OK?	<ul style="list-style-type: none"> • DPOF settings are already specified. • The DPOF file contains an error or was specified on another device. 	To create the DPOF file again and reset all the DPOF settings, press the "MENU/OK" button.
IDPOF FILE ERROR	1000 or more prints were specified in the DPOF frame settings.	The maximum number of frames for which printing can be specified on the same SmartMedia is 999. Set no more than 999 frames.
IZOOM ERROR IFOCUS ERROR	Camera malfunction or fault.	<ul style="list-style-type: none"> • Switch the camera on again taking care not to touch the lens. • Switch the camera on and off again several times. If that does not remedy the problem, contact your FUJIFILM dealer.
IBUSY	The timing for recording was incorrect because the media was formatted on a computer.	Use a media that was formatted on the camera.

Troubleshooting

► If you think the camera is faulty, check the following once more

Troubleshooting	Possible causes	Solutions
The camera won't switch on.	<ul style="list-style-type: none"> • The batteries are exhausted. • The batteries are loaded the wrong way round. • The AC power adapter is not connected correctly. 	<ul style="list-style-type: none"> • Load new or fully charged batteries. • Reload the batteries correctly • Reconnect the adapter correctly and plug the adapter plug into the mains power outlet.
Power cuts out during operation.	<ul style="list-style-type: none"> • The batteries are exhausted. 	<ul style="list-style-type: none"> • Load new or fully charged batteries.
Batteries run out quickly.	<ul style="list-style-type: none"> • You are using the camera in extremely cold conditions. • The battery terminals are soiled. • The battery terminals were soiled when the batteries were charged. • The batteries were charged after having not been used for a long period. • The rechargeable batteries have reached the end of their operating lives. 	<ul style="list-style-type: none"> • Put the batteries in your pocket or another warm place to heat them and then load them into the camera just before you take a picture. Note that alkaline batteries cannot be used at very low temperatures. • Remove the batteries from the camera and wipe the battery terminals with a clean, dry cloth before reloading the batteries. • Wipe the battery terminals with a clean, dry cloth before charging. • Due to their nature, the batteries may not be fully charged. Charge and use the batteries several times to restore them to normal operation. • Load new fully charged batteries.
No photograph is taken when I press the shutter button.	<ul style="list-style-type: none"> • The batteries are exhausted. • The Auto Power Off function has switched the camera off. • There is no media in the camera. • The media is not formatted. • The media is full and no further data can be recorded. • The SmartMedia contact area (the gold-colored area) is soiled. • The SmartMedia is write-protected. • The media is damaged (CARD ERROR). 	<ul style="list-style-type: none"> • Load new or fully charged batteries. • Switch the camera on. • Load a media. • Format the media. • Erase some unwanted frames or load a new media. • Wipe the SmartMedia contact area with a clean, dry cloth. • Remove the write-protection (Peel off the write-protect sticker). • Use a different media.
Focusing is slow.	<ul style="list-style-type: none"> • The SET ADAPTER RING menu in the "SET-UP" menu is "YES". • The external AF sensor is dirty. 	<ul style="list-style-type: none"> • If you are not using an adapter, select the "NO" setting. • Use a blower brush to brush away any dust and then gently wipe the sensor with a soft, dry cloth.
I can't set a voice memo.	<ul style="list-style-type: none"> • Continuous shooting is selected. 	<ul style="list-style-type: none"> • Set continuous shooting to "OFF".
I can't set the self-timer.	<ul style="list-style-type: none"> • Long period or Final 5-frame continuous shooting is selected. 	<ul style="list-style-type: none"> • Select a continuous shooting mode other than Long period or Final 5-frame or set continuous shooting to "OFF".
I can't set the camera to Macro (close-up) mode.	<ul style="list-style-type: none"> • The camera is set to Movie mode or to the Scenery, Sport or Night Scene setting in Scene Position mode. 	<ul style="list-style-type: none"> • Change the photography mode or select Monochrome in Scene Position mode.
I can't select continuous shooting.	<ul style="list-style-type: none"> • Voice memo is selected. • Multi-exposure mode is selected. 	<ul style="list-style-type: none"> • Set voice memo to "OFF". • Set multi-exposure mode to "OFF".
When the resolution is set to 1 , I can only select NORMAL or FINE.	<ul style="list-style-type: none"> • Long period continuous shooting is selected. 	<ul style="list-style-type: none"> • Select a continuous shooting mode other than Long period continuous shooting.
When the resolution is set to 1 , I can only select NORMAL.	<ul style="list-style-type: none"> • The sensitivity (ISO) is set to 800 or 1600 (high-sensitivity photography). 	<ul style="list-style-type: none"> • Set the sensitivity (ISO) to 400 or lower.
I can't use the flash.	<ul style="list-style-type: none"> • The flash is not popped up. • You pressed the shutter button while the flash was charging. • The batteries are exhausted. • The camera is set to Scenery in Scene Position mode 	<ul style="list-style-type: none"> • Pop up the flash. • Wait until the flash has finished charging before pressing the shutter button. • Load new or fully charged batteries. • Select another Scene Position or change the photography mode.

Troubleshooting	Possible causes	Solutions
I can't use the flash.	<ul style="list-style-type: none"> • Continuous shooting is selected. • Super Macro mode is selected. 	<ul style="list-style-type: none"> • Set continuous shooting to "OFF". • Cancel Super Macro mode.
The flash settings are restricted and cannot be selected.	<ul style="list-style-type: none"> • Scene Position mode is selected. 	<ul style="list-style-type: none"> • The flash settings are restricted because the camera settings are tailored to the scene being shot. Change the photography mode for a wider range of flash settings.
I can't set exposure compensation.	<ul style="list-style-type: none"> • The photography mode is set to Auto, Scene Position or Manual. 	<ul style="list-style-type: none"> • Change the photography mode.
I used the flash but the image is still dark.	<ul style="list-style-type: none"> • The subject is too distant. • Your finger is blocking the flash or the flash control sensor. 	<ul style="list-style-type: none"> • Take the picture from within the effective shooting range of the flash. • Hold the camera correctly.
Images shot using the flash are too pale.	<ul style="list-style-type: none"> • The flash control sensor is obscured by soiling. 	<ul style="list-style-type: none"> • Use a thin cotton bud to clean the soiling from the sensor.
The image is blurred.	<ul style="list-style-type: none"> • The shot was taken in dark conditions (using a slow shutter speed) without using the flash (camera shake). • The lens is soiled. • You are photographing scenery with Macro mode selected. • You are taking close-up photographs without selecting Macro mode. • You shot a subject that is not suited to auto focusing. 	<ul style="list-style-type: none"> • Use a tripod or use the flash. • Clean the lens. • Cancel Macro mode. • Select Macro mode. • Use AF/AE lock to take the picture.
There are noise spots on the image.	<ul style="list-style-type: none"> • A slow shutter speed (long exposure) was used to take the shot in hot conditions. • The flash was used when there was a lot of snow or dust in the air. 	<ul style="list-style-type: none"> • This is a characteristic of the CCD and does not indicate a fault. • This is caused by the flash reflecting off the snowflakes or dust particles and does not indicate a fault.
The camera does not emit any sound.	<ul style="list-style-type: none"> • The camera's volume setting is low. • The microphone was covered during shooting/recording. • The speaker was covered during playback. • An A/V cable is connected to the camera. 	<ul style="list-style-type: none"> • Adjust the volume. • Take care not to cover the microphone during shooting/recording. • Take care not to cover the speaker. • Disconnect the A/V cable.
Frame erase does not erase the frame.	<ul style="list-style-type: none"> • DPOF settings are specified for the frame(s). 	<ul style="list-style-type: none"> • Set the DPOF settings to "RESET".
Erase all does not erase all the frames.	<ul style="list-style-type: none"> • The frame(s) is(are) protected. 	<ul style="list-style-type: none"> • Remove the protection using the camera on which the protection was applied.
I can't format the SmartMedia.	<ul style="list-style-type: none"> • The SmartMedia is write-protected. 	<ul style="list-style-type: none"> • Remove the write-protection (peel off the write-protect sticker).
There is no image or sound on the TV.	<ul style="list-style-type: none"> • An A/V cable was connected during movie playback. • The camera is not connected to the TV correctly. • "TV" is selected as the TV input. • The TV volume is turned down. 	<ul style="list-style-type: none"> • Connect the camera and TV correctly. • Connect the camera and TV correctly. • Set the TV input to "VIDEO". • Adjust the volume.
In PC connection mode, the photography screen appears on the camera's LCD monitor.	<ul style="list-style-type: none"> • The special USB cable is not correctly connected to the PC or camera. • The PC is not switched on. 	<ul style="list-style-type: none"> • Connect the cable correctly. • Switch the PC on.
The camera does not operate normally when I press the camera buttons and switches.	<ul style="list-style-type: none"> • The batteries are exhausted. • Camera malfunction or unforeseen camera status. 	<ul style="list-style-type: none"> • Load new or fully charged batteries. • Briefly remove the batteries or disconnect the AC power adapter and then reload the batteries or reconnect the AC power adapter and try using the camera again. If that does not remedy the problem, contact your FUJIFILM dealer.

Specifications

System

- **Model:** Digital camera FinePix S602 ZOOM
- **Number of effective pixels:** 3.1 million pixels
- **CCD sensor**
1/1.7 inch Super CCD in an interwoven pattern
Number of total pixels 3.3 million pixels
- **Number of recorded pixels**
2832 × 2128 pixels (6.03 million pixels) / 2048 × 1536 pixels / 1280 × 960 pixels / 640 × 480 pixels
- **Storage media:** SmartMedia (3.3V), Microdrive
- **File format**
Still image: TIFF-RGB, JPEG (Exif ver. 2.2)
* Design rule for Camera File System compliant
DPOF compatible
Movie: AVI format, Motion JPEG
Audio: WAV format
- **Sensitivity:** Equivalent to ISO 160/200/400/800/1600
- **Lens:** Super EBC Fujinon 6× optical zoom lens
- **Focus distance:** f = 7.8 mm-46.8 mm
(Equivalent to 35 mm-210 mm on a 35 mm camera)
- **Viewfinder:** 0.44-inch 180,000 pixels electronic viewfinder
- **Exposure control**
TTL 64-zones metering, Program AE (R •> • B • M • N • M), Exposure compensation (B • M • N) available
- **White balance**
R •> : Fully automatic
B • M • N: 8 positions selectable
- Custom white balance selectable (2 positions)
- **Focal range**
Normal (wide-angle): Approx. 50 cm (1.6 ft.) to infinity
Normal (telephoto-angle): Approx. 90 (3.0 ft.) cm to infinity
Macro: Approx. 10 cm (3.9 in.) to 80 cm (2.6 ft.)
Super Macro: Approx. 1 cm (0.4 in.) to 20 cm (7.9 in.)
- **Shutter:**
R : Variable-speed, 1/4 sec. to 1/2000 sec.
> : Variable-speed, 3 sec. (Night scenes only) to 1/2000 sec.
B • M • N: Variable-speed, 3 sec. to 1/1000 sec.
< : Variable-speed, 15 sec. to 1/10000 sec.
- **Aperture:** F2.8-F11 13 levels in 1/3 EV steps
- **Focus:** Passive-type external AF sensor + CCD-AF sensor
Focus mode: AF, AREA AF, MF
- **Self-Timer:** 2 sec./10 sec. timer clock
- **LCD monitor:** 1.8 inches, low-temperature polysilicon
TFT 110,000 pixels
- **Flash:** Auto flash using flash control sensor
Effective range: Wide-angle: Approx. 0.3 m-5.4 m
(1.0 ft.-17.7 ft.)
Telephoto-angle: Approx. 0.9 m-5.0 m
(3.0 ft.-16.4 ft.)
Flash modes: Auto, Red-Eye Reduction, Forced Flash, Slow Synchro, Red-Eye Reduction + Slow Synchro
- **Video output**
NTSC (U.S.A./Canada model) / PAL (Europe model)

Standard number of shots per Media

Number of recorded Pixels	3 2832 × 2128				2 2048 × 1536		1 1280 × 960			4 640 × 480		Movie (Video)	
	Quality Mode	HIGH	FINE	NORMAL	BASIC	FINE	NORMAL	FINE	NORMAL	NORMAL	VGA	QVGA	
Image File Size	Approx. 18MB	Approx. 2.4MB	Approx. 1.2MB	Approx. 460KB	Approx. 1.3MB	Approx. 590KB	Approx. 620KB	Approx. 320KB	Approx. 130KB				
MG-4S (4MB)	0	1	3	8	2	6	6	12	30	Approx. 3 sec.	Approx. 6 sec.		
MG-8S (8MB)	0	3	6	17	6	13	12	25	61	Approx. 6 sec.	Approx. 13 sec.		
MG-16S/SW (16MB)	0	6	13	33	12	26	25	49	122	Approx. 13 sec.	Approx. 27 sec.		
MG-32S/SW (32MB)	1	13	28	68	25	53	50	99	247	Approx. 27 sec.	Approx. 55 sec.		
MG-64S/SW (64MB)	3	26	56	137	50	107	101	198	497	Approx. 55 sec.	Approx. 110 sec.		
MG-128SW (128MB)	7	53	113	275	102	215	204	398	997	Approx. 112 sec.	Approx. 222 sec.		
Microdrive 340MB	19	147	311	765	279	589	566	1119	2729	Approx. 307 sec.	Approx. 609 sec.		
Microdrive 1GB	59	443	938	2190	842	1729	1642	3285	8213	Approx. 925 sec.	Approx. 1833 sec.		

Input/Output Terminals

- **DC Input:** To connect the AC power Adapter AC-5V/AC-5VH/AC-5VHS
- **Accessory shoe:** Hot shoe
- **AV Output:** Stereo mini-jack (1)

Power Supply and Others

- **Power supply**
Use one of the following
 - 4 × AA-size alkaline batteries
 - 4 × AA-size Ni-MH (nickel-metal hydride) batteries (sold separately)
 - AC Power Adapter AC-5VH/AC-5VHS (sold separately)
- **Available shots using batteries (When fully charged)**

Media type	Battery type	Alkaline batteries	Ni-MH batteries HR-3UF 1700 mAh
		SmartMedia	Using LCD monitor
	Using EVF	Approx. 210 frames	Approx. 280 frames
Microdrive	Using LCD monitor	Approx. 170 frames	Approx. 230 frames
	Using EVF	Approx. 180 frames	Approx. 240 frames

The number of shots shown here is an approximate guide to the number of consecutive shots that can be taken based on 50% flash usage at normal temperatures. However, the actual number of available shots will vary depending on the ambient temperature when the camera is used and the amount of charge in the battery. The number of available shots will be lower in cold conditions.

- **Conditions for use**
Temperature: 0°C to +40°C (+32°F to +104°F)
80% humidity or less (no condensation)
- **Camera dimensions (W/H/D)**
121.0 mm × 81.5 mm × 97.0 mm / 4.8 in. × 3.2 in. × 3.8 in.
(not including accessories and attachments)
- **Camera mass (weight):** 500 g / 17.6 oz.
(not including accessories, batteries or media)
- **Weight for photography:** Approx. 600 g / 21.2 oz.
(including batteries and SmartMedia)
- **Accessories:** See P.7
- **Optional Accessories:** See P.80

* These specifications are subject to change without notice.
* The LCD monitor and viewfinder on your digital camera is manufactured using advanced high-precision technology. Even so, small bright points and anomalous colors (particularly around text) may appear on the monitor and viewfinder. These are normal display characteristics and do not indicate a fault with the monitor. This phenomenon will not appear on the recorded image.
* The operation error may be caused in a digital camera by the strong radio interference (i. e. electric fields, static electricity, line noise, etc.).

Explanation of Terms

AF/AE Lock:

On the FinePix S602 ZOOM, pressing the shutter button down half way locks the focus and exposure settings (AF and AE lock). If you want to focus on a subject that is not centered in the frame or change the picture composition after the exposure is set, you can obtain good results by changing the composition after the AF and AE settings are locked.

Auto Power Save Function:

If the camera is not used in any way for 30 seconds, this function switches features such as the LCD monitor off (Sleep mode) to prevent battery depletion and the waste of power when the AC power adapter is connected. If the camera is then left unused for a further period, the Auto Power Save function switches the camera off. This period can be set to 2 minutes or 5 minutes on this camera.

- The Auto Power Off function does not operate in PC mode, during automatic playback, or if it is disabled during setup.

DPOF:

Digital Print Order Format

DPOF is a format used for recording information on a storage media (image memory card, etc.) that allows you to specify which of the frames shot using a digital camera are printed and how many prints are made of each image.

EV:

A number that denotes Exposure Value. The EV is determined by the brightness of the subject and sensitivity (speed) of the film or CCD. The number is larger for bright subjects and smaller for dark subjects. As the brightness of the subject changes, a digital camera maintains the amount of light hitting the CCD at a constant level by adjusting the aperture and shutter speed.

When the amount of light striking the CCD doubles, the EV increases by 1. Likewise, when the light is halved, the EV decreases by 1.

JPEG:

Joint Photographics Experts Group

A file format used for compressing and saving color images. The compression ratio can be selected, but the higher the compression ratio, the poorer the quality of the expanded image.

Motion JPEG:

A type of AVI (Audio Video Interleave) file format that handles images and sound as a single file. Images in the file are recorded in JPEG format. Motion JPEG can be played back by QuickTime 3.0 or later.

PC Card:

A generic term for cards that meet the PC Card Standard.

PC Card Standard:

A standard for PC cards determined by the PCMCIA.

PCMCIA:

Personal Computer Memory Card International Association (US).

VGA/QVGA:

Graphics standards for PCs. Images are displayed at 640 × 480 and 320 × 240 pixels respectively.

WAVE:

A standard format used on Windows systems for saving audio data. WAVE files have the ".WAV" file extension and the data can be saved in either compressed or uncompressed format. This camera use PCM recording.

WAVE files can be played back on a personal computer using the following software:

Windows : MediaPlayer

Macintosh: QuickTime Player

* QuickTime 3.0 or later

White Balance:

Whatever the kind of the light, the human eye adapts to it so that a white object still looks white. On the other hand, devices such as digital cameras see a white subject as white by first adjusting the color balance to suit the color of the ambient light around the subject. This adjustment is called matching the white balance. A function that automatically matches the white balance is called an **Automatic White Balance function**.

Smear:

A phenomenon specific to CCDs whereby white streaks appear on the image when there is a very strong light source, such as the sun or reflected sunlight, in the photography screen.





Exif Print Format is a newly revised digital camera file format that contains a variety of shooting information for optimal printing.

Safety Notes

- To ensure that you use your FinePix S602 ZOOM camera correctly, read these Safety Notes and your Owner's Manual carefully beforehand.
- After reading these Safety Notes, store them in a safe place.

About the Icons

The icons shown below are used in this document to indicate the severity of the injury or damage that can result if the information indicated by the icon is ignored and the product is used incorrectly as a result.

 WARNING	This icon indicates that death or serious injury can result if the information is ignored.
 CAUTION	This icon indicates that personal injury or material damage can result if the information is ignored.

The icons shown below are used to indicate the nature of the information which is to be observed.









Triangular icons notify the user of information requiring attention ("Important").



Circular icons with a diagonal bar notify the user that the action indicated is prohibited ("Prohibited").



Filled circles with an exclamation mark notify the user of an action that must be performed ("Required").

 WARNING	
<p>When a fault arises, switch the camera off and then remove the batteries and disconnect the AC power adapter.</p> <p>Continued use of the camera when it is emitting smoke, is emitting any unusual odor, or is in any other abnormal state can cause a fire or electric shock.</p> <ul style="list-style-type: none"> ● Contact your FUJIFILM dealer. 	 Unplug from power socket.
<p>Do not allow water or foreign objects to enter the camera.</p> <p>If water or foreign objects get inside the camera, switch the camera off, remove the battery and disconnect and unplug the AC power adapter.</p> <p>Continued use of the camera can cause a fire or electric shock.</p> <ul style="list-style-type: none"> ● Contact your FUJIFILM dealer. 	
<p>Do not place the camera on an unstable surface.</p> <p>This can cause the camera to fall or tip over and cause injury.</p>	
<p>Do not use the camera in the bathroom or shower.</p> <p>This can cause a fire or electric shock.</p> <ul style="list-style-type: none"> ● Contact your FUJIFILM dealer. 	 Do not use in the bathroom or shower.
<p>Never attempt to modify or disassemble the camera. (Never open the casing.)</p> <p>Do not use the camera when it has been dropped or the casing is damaged.</p> <p>This can cause a fire or electric shock.</p> <ul style="list-style-type: none"> ● Contact your FUJIFILM dealer. 	 Do not disassemble.
<p>Never attempt to take pictures while in motion.</p> <p>Do not use the camera while you are walking or operating a moving car or other vehicle.</p> <p>This can result in you falling down or being involved in a traffic accident.</p>	
<p>Do not heat, modify or attempt to disassemble the batteries.</p> <p>Do not drop or subject the batteries to impacts.</p> <p>Do not attempt to recharge lithium or alkaline batteries.</p> <p>Do not store the batteries with metallic products.</p> <p>Any of these actions can cause the batteries to burst or leak and cause fire or injury as a result.</p>	
<p>Do not touch any metal parts of the camera during a thunderstorm.</p> <p>This can cause an electric shock due to induced current from the lightning discharge.</p>	

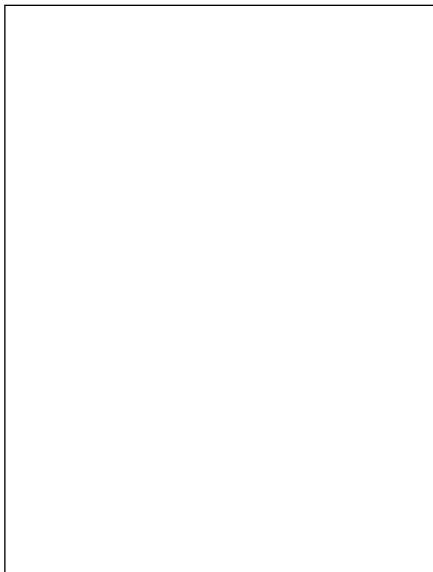

Keep out of the reach of small children.

This product could cause injury in the hands of a child.

Do not use this camera in locations severely affected by oil fumes, steam, humidity or dust.

This can cause a fire or electric shock.

Do not leave this camera in places subject to extremely high temperatures.

Do not leave the camera in locations such as a sealed vehicle or in direct sunlight.

This can cause a fire.

Do not place heavy objects on the camera.

This can cause the heavy object to tip over or fall and cause injury.

Do not move the camera while the AC power adapter is still connected.



FUJI PHOTO FILM CO., LTD.
26-30, Nishiazabu 2-chome, Minato-ku, Tokyo 106-8620, Japan

Printed in Japan

Printed on recycled paper.

FGS-204103-FG