

KAMBROOK

GET MORE THAN YOU PAY FOR™

Jaguar Twister Cordless Hand Vac



KHV100

Issue 1/07

KAMBROOK SAFETY

READ ALL INSTRUCTIONS BEFORE OPERATING AND SAVE FOR FUTURE REFERENCE

Welcome to Kambrook and your new Jaguar Twister Hand Vac.

At Kambrook we believe that the safe performance of our products is the first priority in any consumer product so that you, our valued customer, can confidently use and trust our products.

We ask that any electrical appliance that you use be operated in a sensible fashion with due care and attention placed on the following important operating instructions:

Read all instructions thoroughly before activating the appliance and retain them for future reference.

Ensure that the power source to be used is the same as the voltage requirements of the product.

Never use the hand vac without the dust cup and filters in place.

Never use the hand vac to vacuum hot ashes, broken glass, sharp objects or liquids.

Never use in the presence of explosive liquids or vapours.

Never vacuum up inflammable or poisonous liquids such as petrol, copier toner or other volatile substances. Never vacuum up acids, asbestos or asbestos dust.

This hand vac is not intended for use by young children or infirm persons unless they have been adequately supervised by a responsible person to ensure that they can use the hand vac safely.

Do not leave the hand vac unattended when in use. Young children should be supervised to ensure that they do not play with the hand vac.

Close supervision is required at all times when operating the hand vac near children.

This hand vac is suitable for domestic use only. Do not use this hand vac for anything other than its intended use.

The installation of a residual current device (safety switch) is recommended to provide additional safety protection when using electrical appliances. It is advisable that a safety switch with a rated residual operating current not exceeding 30mA be installed in the electrical circuit supplying the appliance. See your electrician for professional advice.

Regularly inspect the plug and actual appliance for any damage. If found damaged in any way, immediately cease use of the appliance and return the entire appliance to the nearest authorised Kambrook service centre for examination and/or repair.

⚠WARNING: Do not use the hand vac on wet surfaces.

FEATURES OF YOUR KAMBROOK JAGUAR TWISTER CORDLESS HAND VAC

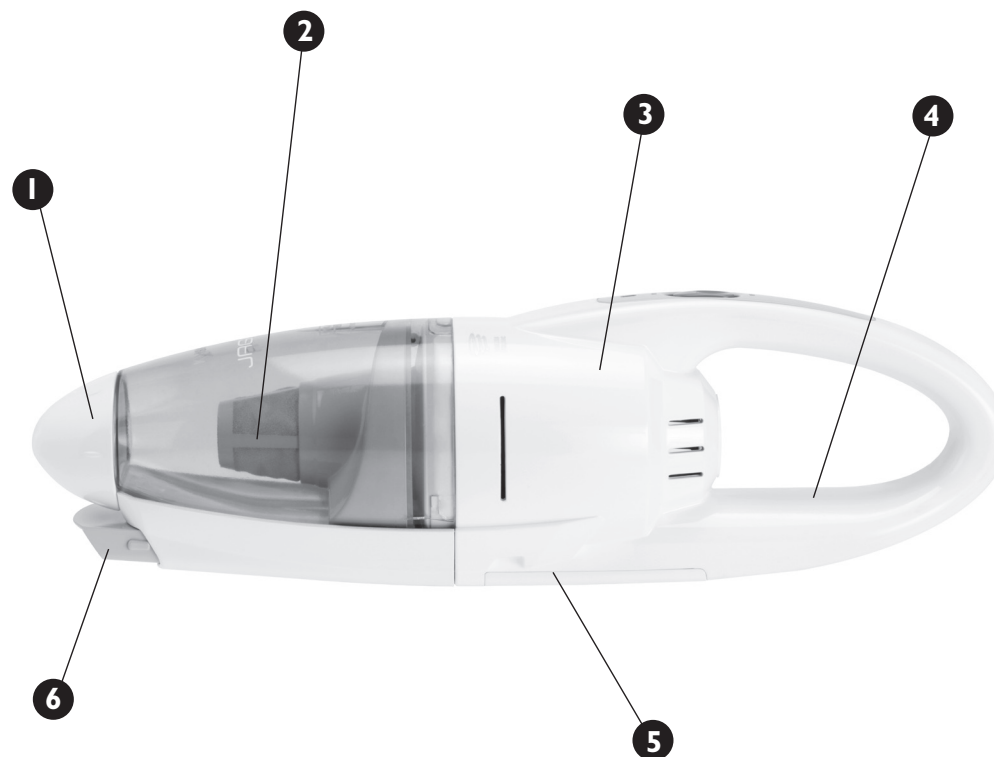

1. Cyclonic system for superior suction power.
2. Dual filter system for fast and effective cleaning.
3. Powerful 12 volts for maximum cleaning performance.

4. Cordless operation for portable use.
5. Rechargeable NIMH battery for long lasting power.
6. Retractable crevice tool for hard to reach places.

USING YOUR KAMBROOK JAGUAR HAND VAC

Remove all packaging from the unit.

Ensure that the dust cup and filters are correctly fitted.

Please charge the battery for 16 hours before first use.

To commence vacuuming, remove the hand vac from the charging base.



Push the on/off button, at the top of the unit in an upward direction to switch the unit on. You must leave your finger in the 'on' position when vacuuming.

When vacuuming is complete, push down on the 'on/off' button to the "off" position. Place the unit immediately back on the charger after each use.

⚠ ALWAYS ENSURE THAT THE DUST CUP AND THE FILTERS ARE CORRECTLY FITTED. NEVER OPERATE WITHOUT THE DUST CUP AND FILTERS IN PLACE.

CREVICE TOOL



The crevice tool is ideal for vacuuming hard to reach places such as the edges along skirting boards, the crevice of car seats and corners.

Simply extend the crevice tool from the unit by pulling the crevice tool away from the unit.

To retract the crevice tool, press the release button under the nozzle and push the crevice back into the unit.



CLEANING THE DUST CUP AND FILTERS

Dirt and debris picked up by your vacuum will collect in the dust cup. The dust cup should be emptied when full.

To empty the dust cup:

Always switch the appliance off prior to replacing filters or emptying the dust cup.

To remove the dust cup locate the release button situated half-way along the underside of the hand vac. With one hand press the release button in an upward direction.



With the other hand hold onto the dust cup and turn in an anti-clockwise direction until the dust cup is released and then lift upwards.



To empty the dust cup simply remove the two filters and empty the dirt and debris straight into a bin.

IMPORTANT: DO NOT USE THE UNIT WITH OUT A DUST CUP OR FILTERS IN PLACE

To clean and replace filters

Filters must be cleaned from time to time to remove the fine dust particles that have been collected.

1. Remove the filter pouch, followed by the filter bracket by lifting them vertically from the dust cup.



2. Shake and tap the filters until all the fine dust particles are removed.

3. The filter pouch and filter bracket can be rinsed in luke warm water. Ensure you let the filter pouch and filter bracket completely dry naturally before next use.

4. To place the filters back in the dust container firstly return the filter bracket directly into the dust cup.



5. Then simply reinsert the filter pouch into the filter bracket (which is sitting in the dust cup)

6. Place the dust cup back into the hand vac unit by fitting the grooves in the dust cup onto the locks of the unit.

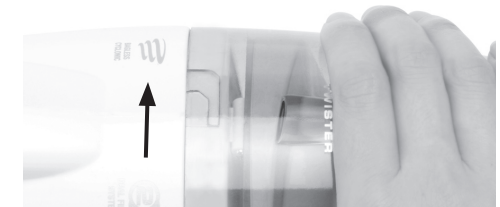

7. Twist the dust cup in a clockwise position until you hear a click.

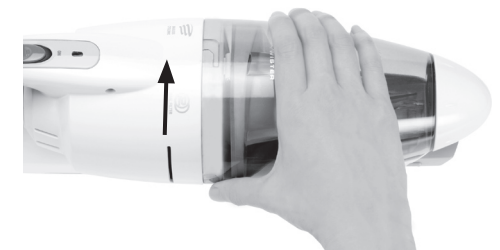

8. Place the unit back onto the charging base to charge up for its next use.



CARE AND MAINTENANCE

Thoroughly cleaning the dust cup and filters on a regular basis will improve the performance of the unit.

To clean the outside of the unit, wipe the exterior with a soft, damp cloth. Never use an abrasive cleaner.

Empty the dust cup on a regular basis. Clean the filters on a regular basis.



Notes

Notes



KAMBROOK 12 MONTH REPLACEMENT WARRANTY

Kambrook warrants the purchaser against defects in workmanship and material for a period of 12 months from the date of purchase (3 months commercial use).

Guarantee and purchase receipt for this product are to be retained as proof of purchase and must be presented if making a claim under the Kambrook guarantee.

Kambrook reserves the right to replace or repair the appliance within the warranty period,

Warranty does not apply to any defect, deterioration, loss, injury or damage occasioned by, or as a result of the misuse or abuse, negligent handling or if the product has not been used in accordance with the instructions. The guarantee excludes breakages and consumable items such as kneading blades.

This warranty is void if there is evidence of the product being tampered with by unauthorised persons.

If the product includes one or a number of accessories only the defective accessory or product will be replaced. In the event of Kambrook choosing to replace the appliance, the guarantee will expire at the original date, i.e. 12 months from the original date of purchase.

In Australia, this KAMBROOK Guarantee is additional to the conditions and guarantees which are mandatory as implied by the Trade Practises Act 1974 and State and Territory legislation.

For service, spare parts or product information in Australia, please call KAMBROOK on the Customer Service Line; 1300 139 798.

For service, spare parts or product information in New Zealand, please call KAMBROOK New Zealand; 0800 273 845. For spare parts phone 0800 273 845.

If claiming this guarantee the product must be returned freight prepaid.

KAMBROOK 12 MONTH REPLACEMENT WARRANTY

YOUR PURCHASE RECORD (Please complete)

Attach a copy of the purchase receipt here.

DATE OF PURCHASE _____

MODEL NUMBER _____

SERIAL NUMBER _____

PURCHASED FROM _____

(Please don't return purchase record until you are making a claim)

Register your warranty at www.kambrook.com.au/service.asp

KAMBROOK
GET MORE THAN YOU PAY FOR

Kambrook - Australia

461 Plummer Street, Port Melbourne, 3207, Australia

Customer Service Line 1300 139 798

Customer Service Fax 1800 621 337

Kambrook - New Zealand

Private Bag 94411, Greenmount, Auckland, New Zealand

Customer Service Line/Spare Parts 09 271 3980

Customer Service Fax 0800 288 513

Due to continual improvement in design or otherwise, the product you purchase may differ slightly from the illustration in this book. Issue 1/07

