



EN

FR

ES

## Mobile Multimedia Station

# IVA-D300



**MP3 MLX**



**((( XM )))  
READY**



- **OWNER'S MANUAL**  
Please read before using this equipment.
- **MODE D'EMPLOI**  
Veuillez lire avant d'utiliser cet appareil.
- **MANUAL DE OPERACIÓN**  
Léalo antes de utilizar este equipo.

**ALPINE ELECTRONICS MARKETING, INC.**  
1-1-8 Nishi Gotanda,  
Shinagawa-ku,  
Tokyo 141-0031, Japan  
Phone 03-5496-8231

**ALPINE ELECTRONICS OF AMERICA, INC.**  
19145 Gramercy Place, Torrance,  
California 90501, U.S.A.  
Phone 1-800-ALPINE-1 (1-800-257-4631)

**ALPINE ELECTRONICS OF CANADA, INC.**  
7300 Warden Ave., Suite 203, Markham,  
Ontario L3R 9Z6, Canada  
Phone 1-800-ALPINE-1 (1-800-257-4631)

**ALPINE ELECTRONICS OF AUSTRALIA PTY. LTD.**  
6-8 Fiveways Boulevard Keysborough,  
Victoria 3173, Australia  
Phone 03-9769-0000

**ALPINE ELECTRONICS GmbH**  
Frankfurter Ring 117  
80807 München, Germany  
Phone 089-32 42 640

**ALPINE ELECTRONICS OF U.K. LTD.**  
Alpine House  
Fletchamstead Highway, Coventry CV4 9TW, U.K.  
Phone 0870-33 33 763

**ALPINE ELECTRONICS FRANCE S.A.R.L.**  
(RCS PONTOISE B 338 101 280)  
98, Rue de la Belle Etoile, Z.I. Paris Nord II,  
B.P. 50016, 95945 Roissy Charles de Gaulle  
Cedex, France  
Phone 01-48638989

**ALPINE ITALIA S.p.A.**  
Viale C. Colombo 8, 20090 Trezzano  
Sul Naviglio (MI), Italy  
Phone 02-484781

**ALPINE ELECTRONICS DE ESPAÑA, S.A.**  
Portal de Gamarra 36, Pabellón, 32  
01013 Vitoria (Alava)-APDO 133, Spain  
Phone 945-283588

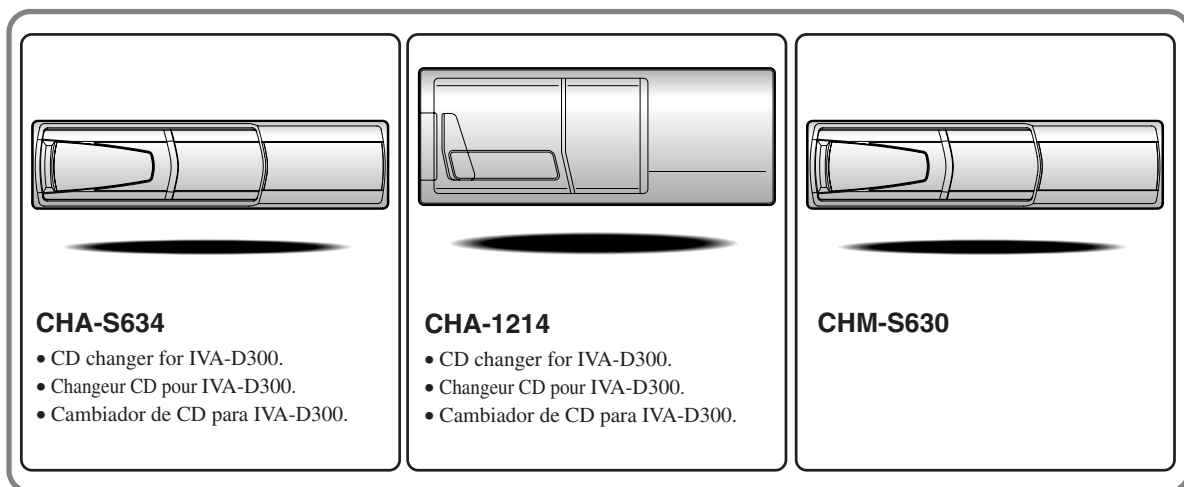

## Alpine CD Changers Give You More!

***More musical selections, more versatility, more convenience.***

The CHA-S634 is a high-performance 6-disc changer with a new M DAC, CD-R/RW PLAY BACK, MP3 PLAY BACK and CD TEXT. The CHA-1214 Ai-NET model holds 12 discs, and the CHM-S630 M-Bus model is a super-compact 6-disc changer with a CD-R/RW PLAY BACK.

## Changeurs de CD Alpine : vous avez le choix!

***Plus de sélections musicales, plus de souplesse, plus de confort.***

Le modèle CHA-S634 est un changeur 6 disques ultra performant équipé des nouvelles fonctions M DAC, CD-R/RW PLAY BACK, MP3 PLAY BACK et CD TEXT. Le modèle CHA-1214 Ai-NET contient 12 disques. Le modèle CHM-S630 M-Bus est un changeur 6 disques super compact doté de la fonction CD-R/RW PLAY BACK.

## ¡Los cambiadores Alpine de CD le ofrecen más!

***Más selecciones musicales, más versatilidad y más ventajas.***

CHA-S634 es un cambiador de seis discos de alto rendimiento con nuevo M DAC, CD-R/RW PLAY BACK, MP3 PLAY BACK y CD TEXT. El modelo CHA-1214 Ai-NET alberga 12 discos y el modelo CHM-S630 M-Bus es un cambiador de seis discos de tamaño reducido con un CD-R/RW PLAY BACK.

# Contents

## Operating Instructions



### WARNING

<b>WARNING</b> .....	<b>4</b>
<b>CAUTION</b> .....	<b>4</b>
<b>PRECAUTIONS</b> .....	<b>5</b>
<b>Discs playable on this unit</b> .....	<b>6</b>

## Getting Started

Location of Controls .....	9
Using Face Cover .....	9
Initial System Start-Up .....	9
Turning Power On or Off .....	10
Opening/Closing the Monitor .....	10
Moving the Monitor to be Flat .....	10
Adjusting the Volume .....	10
Lowering Volume Quickly .....	10
How to view the Display .....	10
Touch button operation .....	10
Recalling the Source .....	11
Shortcut Screen .....	11
Displaying the Numeric Keypad Input Screen ...	12
Dual-Screen Display .....	12

## Radio

Listening to the Radio .....	13
Manual Storing of Station Presets .....	13
Automatic Memory of Station Presets .....	13
Tuning to Preset Stations .....	13
Searching from Radio Station Title .....	13

## CD/MP3/WMA

Playback .....	14
Repeat Play .....	15
M.I.X. (Random Play) .....	15
Selecting Folders (concerning MP3/WMA) ...	15
About MP3/WMA .....	15

## DVD/Video CD

Playing DVD/Video CD .....	17
To display the DVD mode screen .....	17

If a menu screen appears .....	18
Displaying the Top Menu Screen (DVD only) .....	19
Displaying the Menu Screen (DVD only) ....	19
Displaying the Menu Operation Mode Screen (DVD only) .....	19
Turning the PBC Function ON or OFF (Video CD only) .....	19
Stopping Playback (PRE STOP) .....	19
Stopping Playback .....	19
Fast-forwarding/Fast-reversing .....	19
Finding the Beginnings of Chapters or Tracks .....	20
Playing Still Frames (Pausing) .....	20
Frame-by-frame Playback .....	20
Slow Motion Playback .....	20
Chapter/Track/Title Repeat Playback .....	20
Searching by Title Number (DVD only) .....	20
Searching Directly by Chapter or Track Number .....	21
Switching the Angle (DVD only) .....	21
Switching the Audio Tracks .....	21
Switching the Subtitles (Subtitle Language) (DVD only) .....	21
Switching from the disc menu .....	21
Displaying the Disc Status for DVD/Video CD .....	21

## Other Useful Features

Adjusting the Audio .....	22
Titling Discs/Radio Stations .....	22
Disc Search Function .....	23
Rear Entertainment Function .....	23
Switching the function of the remote sensor ...	24
Switching Display Modes .....	24
Switching the Visual Source Only (Simultaneous Function) .....	25
Canceling the Simultaneous Function .....	25
Blackout Mode On and Off .....	25
Setting VISUALIZER .....	25
Setting the Visual Effect .....	25

## Monitor Setting

Monitor Setting Operation .....	26
Adjusting the Monitor Angle .....	26
Selecting the Monitor Position .....	26
Setting Automatic Opening/Closing of the Monitor .....	26

## Setup

### DVD Setup

DVD Setup Operation .....	27
Setting of the Menu Language .....	28
Setting of the Audio Language .....	28
Setting of the Subtitle Language .....	28
Changing the Country Code Setting .....	28
Setting the Rating Level (Parental Lock) .....	28
Changing the Digital Output Setting .....	28
Setting the Digital Output .....	30
Setting the TV Screen Setting .....	30

### GENERAL Setup

General Setup Operation .....	30
Displaying the Time .....	31
Setting the Time .....	31
Setting Daylight Saving Time .....	31
Demonstration Function .....	31
Sound (Beep) Guide Function .....	31
Setting the Scroll .....	31
Setting the Sound Quality of the Tuner .....	31
Setting the Auxiliary Data Field Display .....	31
Switching the incoming calls of the telephone .....	31
Playing MP3/ WMA Data .....	31

### SYSTEM Setup

System Setup Operation .....	32
Setting the External Device Interrupt Mode .....	32
Setting the Interrupt Icon Display .....	32
Setting the Navigation Mode .....	32
Setting the Navigation Interruption .....	32
Connecting and Setting the External Expansion Box .....	33
Setting the VISUALIZER Mode Display .....	33
Setting the AUX Mode .....	33
Naming External Devices .....	33
Adjusting the External Input Audio Level .....	33

Setting of the External Monitor Output .....	33
Setting of the Rear Camera .....	33
Setting Visual Mode .....	33
Optical Digital Input Selection for an External Audio Processor .....	34

### DISPLAY Setup

Display Setup Operation .....	34
Illumination Control .....	34
Adjusting the Minimum Level of Backlight .....	34
Switching Background Textures .....	34
Setting Automatic Background Textures .....	35
Setting the Font Type .....	35
Switching the Font Back Display Color .....	35
Turning the Touch Panel Vibration ON or OFF .....	35
Adjusting the Touch Panel .....	35

### i-Personalize™

#### Media Xpander Function

Setting the MX mode .....	35
---------------------------	----

#### Bass Engine Function

Setting the Bass Engine .....	36
Selecting Bass EQ mode (Maker's setting) .....	36
Adjusting and Storing/Recalling the Parametric EQ .....	36
About the Time Correction .....	37
Adjusting and Storing/Recalling the Bass Focus .....	38
Adjustment and Storing/Recalling of Time Correction .....	39
Adjustment and Storing/Recalling of the Built-in Crossover .....	39
Subwoofer On and Off .....	40

#### VISUAL EQ™

Visual EQ Setting Operation .....	40
Selecting the VISUAL EQ Mode (Maker's setting) .....	40
Adjusting Brightness .....	40
Adjusting Color of Picture .....	41
Adjusting Tint of Picture .....	41
Adjusting Image Contrast .....	41
Adjusting Picture Quality .....	41
Storing VISUAL EQ .....	41

## Data Download

About SOUND SETUP Download .....	41
Data Downloading .....	42

## Setting AMP Link (Optional)

Adjusting and Storing/Recalling the External Amplifier (Option) .....	42
Titling the Amplifier .....	43
Displaying Status of External Amplifier .....	43

## External Audio Processor (Optional)

Adjustment Procedure for Dolby Surround ....	44
Setting the Speakers .....	44
Set MX Mode of the External Audio Processor .....	44
X-OVER Adjustment .....	45
Performing Time Correction Manually (TCR) ...	45
Phase Switching .....	46
Graphic Equalizer Adjustments .....	46
Parametric Equalizer Adjustments .....	47
Setting Bass Sound Control .....	47
Setting Bass Compressor .....	47
Setting Bass Focus .....	47
Speaker Setup .....	48
Setting of Dolby 5.1ch .....	48
Adjusting the acoustic image .....	48
Mixing bass sound to the rear channel .....	48
Achieving powerful high volume sound .....	49
Adjusting the speaker levels .....	49
Adjusting the DVD Level .....	49
Storing Settings in the Memory .....	49
Getting out the Preset Memory .....	49
Using the Pro Logic II Mode .....	50
Linear PCM Setting .....	50

## Navigation System (Optional)

Switching the Navigation Screen (Optional) .....	51
--	----

## Auxiliary Device (Optional)

Operating Auxiliary Devices (Optional) .....	51
--	----

## Changer (Optional)

Controlling CD Changer (Optional) .....	52
Multi-Changer Selection (Optional) .....	52

## HDD Player Operation (Optional)

Listening to Music of HDD .....	53
---------------------------------	----

## XM Radio (Optional)

Receiving XM Channels with the XM Receiver (Optional) .....	53
Tuning in to Categorized Programs .....	54
Changing the Display .....	54
Checking the XM Radio ID Number .....	54
Storing XM Channel Presets .....	54
Receiving Stored XM Channels .....	54
Displaying the Category/Channel Name Title List .....	55
Selecting the Channel directly .....	55

## MobileHub™ Link (Optional)

About MobileHub™ Link (Optional) .....	55
Telephone Reception .....	56
Calling .....	56
Calling by using the Speed Dial .....	56
Dial call .....	56
Calling by the address book .....	56
Calling by the outgoing / incoming / absent incoming history .....	56
SMS (Short Message Service) Operation .....	57
Receiving a Short message .....	57

## Information

About DVDs .....	57
Terminology .....	58
List of Language Codes .....	59
List of Country Codes .....	60
In Case of Difficulty .....	62
Specifications .....	65

---

## Installation and Connections



### WARNING

---

<b>Warning</b> .....	66
<b>Caution</b> .....	66
<b>Precautions</b> .....	66
Installation .....	67
Connections (IVA-D300 Wiring Diagram) .....	70
System Example .....	72

## LIMITED WARRANTY

---

# Operating Instructions

---

## WARNING



**This symbol means important instructions. Failure to heed them can result in serious injury or death.**

---

### **INSTALL THE PRODUCT CORRECTLY SO THAT THE DRIVER CANNOT WATCH TV/VIDEO UNLESS THE VEHICLE IS STOPPED AND THE EMERGENCY BRAKE IS APPLIED.**

It is dangerous (and illegal in many states) for the driver to watch TV/Video while driving a vehicle. Installing this product incorrectly enables the driver to watch TV/Video while driving. This may cause a distraction, preventing the driver from looking ahead, thus causing an accident. The driver or other people could be severely injured.

---

### **DO NOT WATCH VIDEO WHILE DRIVING.**

Watching the video may distract the driver from looking ahead of the vehicle and cause an accident.

---

### **DO NOT OPERATE ANY FUNCTION THAT TAKES YOUR ATTENTION AWAY FROM SAFELY DRIVING YOUR VEHICLE.**

Any function that requires your prolonged attention should only be performed after coming to a complete stop. Always stop the vehicle in a safe location before performing these functions. Failure to do so may result in an accident.

---

### **KEEP THE VOLUME AT A LEVEL WHERE YOU CAN STILL HEAR OUTSIDE NOISE WHILE DRIVING.**

Failure to do so may result in an accident.

---

### **MINIMIZE DISPLAY VIEWING WHILE DRIVING.**

Viewing the display may distract the driver from looking ahead of the vehicle and cause an accident.

---

### **DO NOT DISASSEMBLE OR ALTER.**

Doing so may result in an accident, fire or electric shock.

---

### **USE ONLY IN CARS WITH A 12 VOLT NEGATIVE GROUND.**

(Check with your dealer if you are not sure.) Failure to do so may result in fire, etc.

---

### **KEEP SMALL OBJECTS SUCH AS BATTERIES OUT OF THE REACH OF CHILDREN.**

Swallowing them may result in serious injury. If swallowed, consult a physician immediately.

---

### **USE THE CORRECT AMPERE RATING WHEN REPLACING FUSES.**

Failure to do so may result in fire or electric shock.

---

### **DO NOT BLOCK VENTS OR RADIATOR PANELS.**

Doing so may cause heat to build up inside and may result in fire.

---

### **USE THIS PRODUCT FOR MOBILE 12V APPLICATIONS.**

Use for other than its designed application may result in fire, electric shock or other injury.

---

### **DO NOT PLACE HANDS, FINGERS OR FOREIGN OBJECTS IN INSERTION SLOTS OR GAPS.**

Doing so may result in personal injury or damage to the product.



**This symbol means important instructions. Failure to heed them can result in injury or material property damage.**

---

### **HALT USE IMMEDIATELY IF A PROBLEM APPEARS.**

Failure to do so may cause personal injury or damage to the product. Return it to your authorized Alpine dealer or the nearest Alpine Service Center for repairing.

---

### **KEEP FINGERS AWAY WHILE THE MOTORIZED FRONT PANEL OR MOVING MONITOR IS IN MOTION.**

Failure to do so may result in personal injury or damage to the product.



# PRECAUTIONS

## Product Cleaning

Use a soft dry cloth for periodic cleaning of the product. For more severe stains, please dampen the cloth with water only. Anything else has the chance of dissolving the paint or damaging the plastic.

## Temperature

Be sure the temperature inside the vehicle is between +45°C (+113°F) and 0°C (+32°F) before turning your unit on.

## Moisture Condensation

You may notice the disc playback sound wavering due to condensation. If this happens, remove the disc from the player and wait about an hour for the moisture to evaporate.

## Damaged Disc

Do not attempt to play cracked, warped, or damaged discs. Playing a bad disc could severely damage the playback mechanism.

## Maintenance

If you have problems, do not attempt to repair the unit yourself. Return it to your Alpine dealer or the nearest Alpine Service Station for servicing.

## Never Attempt the Following

Do not grip or pull out the disc while it is being pulled back into the player by the automatic reloading mechanism. Do not attempt to insert a disc into the unit when the unit power is off.

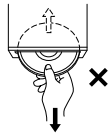

## Inserting Discs

Your player accepts only one disc at a time for playback. Do not attempt to load more than one disc. Make sure the label side is facing up when you insert the disc. Your player will automatically eject any disc that is inserted incorrectly. If the player continues to eject a correctly inserted disc, push the RESET switch with a pointed object such as a ballpoint pen.

Playing a disc while driving on a very bumpy road may result in skips, but this will not scratch the disc or damage the player.

## Irregular Shaped Discs

Be sure to use round shaped discs only for this unit and never use any special shaped discs. Use of special shaped discs may cause damage to the mechanism.



## New Discs

As a protective measure to prevent the disc from jamming, the DVD player will automatically eject discs with irregular surfaces or inserted incorrectly. When a new disc is inserted into the player and ejected after initial loading, using your finger, feel around the inside of the center hole and outside edge of the disc. If you feel any small bumps or irregularities, this could inhibit proper loading of the disc. To remove the bumps, rub the inside edge of the hole and outside edge of the disc with a ball-point pen or other such instrument, then insert the disc again.

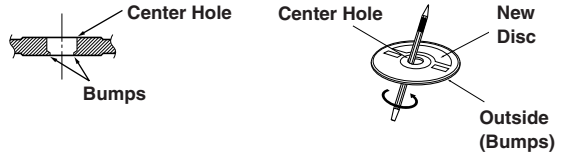

## Installation Location

Make sure the IVA-D300 will not be installed in a location subjected to:

- Direct sun and heat
- High humidity and water
- Excessive dust
- Excessive vibrations

## Correct Handling

Do not drop the disc while handling. Hold the disc so you will not leave fingerprints on the surface. Do not affix tape, paper, or gummed labels to the disc. Do not write on the disc.

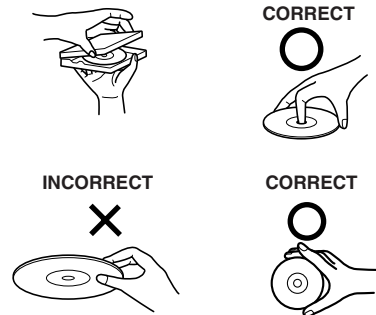

## Disc Cleaning

Fingerprints, dust, or soil on the surface of the disc could cause the DVD player to skip. For routine cleaning, wipe the playing surface with a clean, soft cloth from the center of the disc to the outer edge. If the surface is heavily soiled, dampen a clean, soft cloth in a solution of mild neutral detergent before cleaning the disc.



Continued

## Disc Accessories

There are various accessories available on the market for protecting the disc surface and improving sound quality. However, most of them will influence the thickness and/or diameter of the disc. Using such accessories can cause operational problems. We recommend not using these accessories on discs played in Alpine DVD players.

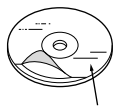

Transparent Sheet

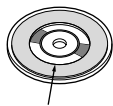

Disc Stabilizer

## Handling the Detachable Front Panel

- Do not expose to rain or water.
- Do not drop or subject to shock.
- After turning the system off, a slight ghost of the image will remain temporarily. This is an effect peculiar to LCD technology and is normal.
- In cold temperature conditions, the screen may lose contrast temporarily. After a short warm-up period, it will return to normal.

Alpine products equipped with the Ai-NET bus, connected to the IVA-D300, can be operated from the IVA-D300. Depending on the products connected, the functions and displays will vary. For details, consult your Alpine dealer.

Remove the anti-theft cover when you drive. This prevents the cover from falling off the unit and interfering with the safe operation of the vehicle.

Operation of some of the functions of this unit is very complex. Because of this, it was deemed necessary to place these functions into a special screen. This will restrict operation of these functions to times when the vehicle is parked. This ensures the focus of the driver's attention will be on the road and not on the IVA-D300. This has been done for the safety of the driver and passengers.

Title Input and Audio Processor Adjustments cannot be made if the car is moving. The car must be parked and the parking brake must be engaged for the procedure described in the Owner's Manual to be valid. The warning "CAN'T OPERATE WHILE DRIVING," will be displayed if any attempts are made to perform these operations while driving.

This operation is the same as when selecting sources using the remote control. When the car is parked, the selection is made as described in the Owner's Manual.

## Discs playable on this unit

### Playable Discs

The discs listed below can be played on this unit.

	Mark (logo)	Recorded content	Disc size	Max. playing time
DVD Video		Audio + Video (Moving pictures)	12 cm*	One-sided disc Approx. 4 hours
				Two-sided disc Approx. 8 hours
			8 cm	One-sided disc Approx. 80 Minutes
				Two-sided disc Approx. 160 Minutes
Video CD		Audio + Video (Moving pictures)	12 cm	Approx. 74 Minutes
			8 cm	Approx. 20 Minutes
Music CD		Audio	12 cm	Approx. 74 Minutes
			8 cm (CD single)	Approx. 20 Minutes

\* Two-layer DVD disc compatible



---

### Discs that cannot be played

DVD-ROMs, DVD-RAMs, DVD + Rs, DVD + RWs, CD-ROMs (excluding MP3/WMA files), photo CDs, etc.

---

### DVD region number (playable region number)

This DVD player will play back any disc whose region number is 1 (or All). DVDs with a region number other than those listed below, cannot be played on this DVD player.



---

### Video CDs

This DVD head unit is compatible with playback control (PBC) compatible video CDs (version 2.0).

“PBC” is a function by which you can use menu screens recorded on the disc to find the scene you want to watch and view various types of information in dialog style.

---

### Using compact discs (CD/CD-R/CD-RW)

If you use unspecified compact discs, correct performance cannot be guaranteed.

You can play CD-Rs (CD-Recordable)/CD-RWs (CD-ReWritable) which have been recorded only on audio devices. You can also play CD-Rs/CD-RWs containing MP3/WMA formatted audio files.

- Some of the following discs may not play on this unit:  
Flawed discs, discs with fingerprints, discs exposed to extreme temperatures or sunlight (e.g., left in the car or this unit), discs recorded under unstable conditions, discs on which a recording failed or a re-recording was attempted, copy-protected CDs which do not conform to the audio CD industry standard.
- Use discs with MP3/WMA files written in a format compliant with this unit. For details, see pages 15 and 16.

To customers using CD-R/CD-RW

- If a CD-R/CD-RW cannot be played back, make sure the last recording session was closed (finalized).
- Finalize the CD-R/CD-RW if necessary, and attempt playback again.

---

### Tips for making your own CDs

The IVA-D300 plays DVD Video, Video CD, Audio CD and has a built in MP3/WMA decoder.

The following information is designed to help you create your own music CDs (either Audio CD or MP3/WMA encoded CD-R/RW files).

#### What is the difference between an Audio and MP3/WMA CD?

An Audio CD is the same format as the commercial CDs you buy in the store (also known as CD-DA). MP3 (MPEG-1 Audio Layer 3)/WMA (Windows Media Audio) is a data file that uses a compression scheme to reduce the size of the music file.\*

#### Hybrid Audio CD and Data (MP3/WMA) CD-R/RW discs:

The IVA-D300 can read either sector on the disc. Choose CD-DA to play the CD audio section or MP3/WMA to play the MP3/WMA section.\*

#### Multisession CD-R/RW:

Once a recording has been stopped, this is considered one session. If the disc is not closed (finalized), additional data may be added. Once this additional data has been recorded, this becomes a “multisession” CD. The IVA-D300 can only read multisession DATA Formatted discs (MP3/WMA files - Not Audio CD files).

#### MP3 ID3 Tag/WMA Tag Information:

The IVA-D300 read and displays MP3 ID3v1 tag or WMA tag information. MP3 files created with ID3v2 tag information can be played back but the tag info cannot be read or displayed.

#### Properly formatted MP3/WMA Discs:

Use ISO9660 formatting to insure proper playback. You may use standard ISO naming Level 1 (8.3 DOS standard), Level 2 (32 characters) or Joliet (Windows or Macintosh long filenames) file naming conventions\*.

\*Please consult the Owner’s manual for additional information.

#### On handling compact discs (CD/CD-R/CD-RW)

- Do not touch the surface.
- Do not expose the disc to direct sunlight.
- Do not affix stickers or labels.
- Clean the disc when it is dusty.
- Make sure that the disc is smooth and flat.
- Do not use commercially available disc accessories.

#### Do not leave the disc in the car or the unit for a long time.

#### Never expose the disc to direct sunlight.

Heat and humidity may damage the disc and you may not be able to play it again.

---

### Using DVD-Rs/DVD-RWs

- This unit is compatible only with discs recorded in the DVD-Video mode.  
Discs recorded in the DVD-VR mode cannot be played back.
- Note that discs not finalized (processed to enable to play on playback-only DVD players) cannot be played on this DVD player.
- Some discs may not play back, depending on the recording device. (This unit has a copy protection function. Discs copied illegally will not be played back. Some files recorded by a software using an improper recording system may be recognized as illegally copied.)
- In the following cases, the disc may not play on this unit: discs recorded by certain DVD recorders, certain irregular discs, flawed discs, dirty discs, when the pickup lens of this DVD player is dirty, or when moisture condensation has occurred inside the unit.
- Be sure to follow all cautions included with your DVD-Rs/ DVD-RWs discs.
- Do not put stickers, seals, or tape on the label side of DVD-Rs/ DVD-RWs.
- Compared to the regular discs, DVD-Rs/DVD-RWs are more affected by heat, moisture, and direct sunlight. If left in a car, etc., damage may occur and it might not play on this unit.

---

## Disc terminology

### Title

If titles are programmed for the DVD, these are the largest units of division of the information recorded on the disc.

### Chapter

Each Title may also be divided into smaller divisions, called chapters. These can be specific scenes or musical selections.

- *This product incorporates copyright protection technology that is protected by method claims of certain U.S. patents and other intellectual property rights owned by Macrovision Corporation and other rights owners. Use of this copyright protection technology must be authorized by Macrovision Corporation, and is intended for home and other limited viewing uses only unless otherwise authorized by Macrovision Corporation. Reverse engineering or disassembly is prohibited.*
- *Manufactured under license from Dolby Laboratories. "Dolby," "Pro Logic" and the double-D symbol are trademarks of Dolby Laboratories. Confidential unpublished works. ©1992-1997 Dolby Laboratories. All rights reserved.*
- *"DTS" and "DTS2.0 + Digital Out" are trademarks of Digital Theater Systems, inc.*
- *Windows Media and the Windows logo are trademarks, or registered trademarks of Microsoft Corporation in the United States and/or other countries.*

# Getting Started

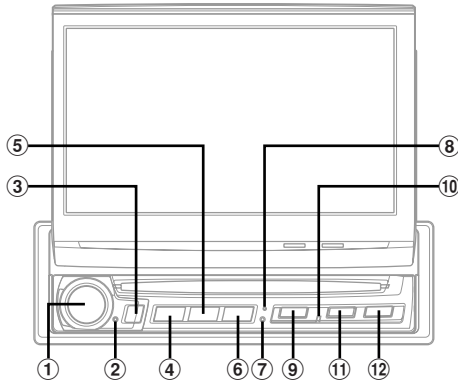

## Location of Controls

- ① **Rotary encoder**  
Adjust the volume by turning to the left or right.  
If pressed, the audio adjusting screen is displayed.
- ② **Access Indicator**  
Blinks when an operation is performed (except when the volume is adjusted).
- ③ **Remote Sensor**  
Point the optional remote control transmitter toward the remote sensor within a range of 2 m.
- ④ **SOURCE/POWER button**  
Turns the power on. Press and hold for at least 2 seconds to turn the power off.  
Recalls the source selection screen.
- ⑤ **BAND/TEL. button**  
Radio mode: Changes the band.  
Visual source (except navigation screen): Changes the display mode.  
Press and hold for at least 2 seconds to change to the TEL. mode, and to be able to place or cut a call. (When MobileHub (CXA-B200NK) is connected.)
- ⑥ **V.SEL/OFF button**  
The visual selecting screen is displayed.  
Press and hold for at least 2 seconds to cancel the Simultaneous function.
- ⑦ **V.SEL Indicator**  
Lights when the simultaneous function is activated. (See "Switching the Visual Source Only (Simultaneous Function)" on page 25.)
- ⑧ **Reset Switch**  
Be sure to press the **Reset** switch when using the unit for the first time, after changing the car battery, or when an operation cannot be performed.
- ⑨ **MUTE button**  
Turns the MUTE mode ON or OFF.
- ⑩ **DISC-IN Indicator**  
This indicator is lit when a disc is inserted.
- ⑪ **▲ button**  
Ejects a disc.
- ⑫ **OPEN/CLOSE/FLAT button**  
Raises the monitor.  
Press and hold for at least 2 seconds to lower the monitor.  
Press to move the open monitor to the flat position.

## About the expression of buttons in this Owner's Manual

- The buttons on this unit are expressed in bold (e.g. **SOURCE/POWER**). The touch buttons on the display are expressed in bold with [ ] (e.g. [**SRC**]).
- This Owner's Manual explains mainly the function of touch buttons, when a touch button and a unit button have the same function.

## Using Face Cover

An anti-theft face cover is provided with the IVA-D300.

Put the face cover onto the IVA-D300 when you leave the vehicle.

Be sure to remove the anti-theft face cover when you drive.

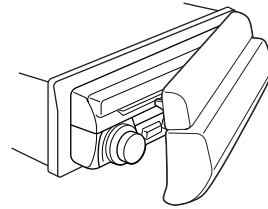

## Initial System Start-Up

Immediately after installing or applying power to the unit, it should be initialized. Press the **RESET** switch with a ballpoint pen or any other pointed object.

- If the monitor was open before resetting, it will close automatically after a reset is performed. None of the buttons will function while it is closing.

---

## Turning Power On or Off

---

Some of this unit's functions cannot be performed while the vehicle is in motion. Be sure to stop your vehicle in a safe location and apply the parking brake, before attempting these operations.

### 1 Press **SOURCE/POWER** to turn on the unit.

- The unit can be turned on by pressing any button on the unit except **OPEN** and **▲** (Eject).

### 2 Press and hold **SOURCE/POWER** for at least 2 seconds to turn off the unit.

- The IVA-D300 draws minimal current even when its power switch is turned off. If the switched power (ignition) lead of the IVA-D300 is connected directly to the positive (+) post of the vehicle's battery, the battery may be discharged. If this lead is unswitched, it must be disconnected from the battery post should the vehicle be left unused for an extended period of time.

An SPST (Single-Pole, Single-Throw) switch (sold separately) can be added to simplify this procedure. Then, you can simply place it in the OFF position when you leave the vehicle. Turn the SPST switch back ON before using the IVA-D300. For connecting the SPST switch, refer to the "Connection Diagram of SPST switch" (page 69).

- Some operation of the unit cannot be performed while the vehicle is in motion. In this case, be sure to first stop your vehicle and apply the parking brake, then perform the operation.

---

## Opening/Closing the Monitor

---

### 1 Press **OPEN**.

The unit beeps 3 times and opens the monitor automatically.

### 2 Press and hold **OPEN (CLOSE)** for at least 2 seconds.

The unit beeps 3 times and closes the monitor automatically.

- Opening/closing the monitor should never be performed manually. It may cause a malfunction.
- The monitor's angle is set to 90 degrees at the factory. Depending on the car, the monitor may hit the dashboard when opened. The monitor's angle can be adjusted and stored in memory so that the monitor will not hit the dashboard when opening. For adjusting the monitor, refer to "Adjusting the monitor Angle" on page 26. Even when the vehicle's battery power is removed, the adjusted monitor angle remains stored in memory.
- The IVA-D300 is a precision device. With gentle handling, its unique capabilities can be enjoyed for a long time.
- If the monitor touches anything while it is being opened (or closed), the monitor will stop opening (or closing) immediately. Should this occur, remove the obstacle and press and hold **OPEN** for at least 2 seconds again to lower the monitor.
- When the movable monitor is opened, do not place any object on the monitor and be careful not to bump or apply any pressure to the monitor while it is open. This can cause damage to the mechanism.
- In low ambient temperature conditions, the display may be dark for a short period of time immediately after the power is turned on. Once the LCD has warmed up, the display returns to normal.
- For your safety, some operation of the unit cannot be performed while the vehicle is in motion. In this case, first stop the vehicle and engage the parking brake, then perform the operation.

---

## Moving the Monitor to be Flat

---

When you want to operate some function on the car (air conditioner, etc.) which is hidden by the raised monitor, use this function.

### 1 Press **OPEN (FLAT)**.

The monitor moves to the flat position.

### 2 Press **OPEN (FLAT)** again.

The monitor returns to the previous angle.

- The monitor returns to the previous angle 10 seconds after being moved to the flat position.
- If an excessive force is added to the monitor when the monitor is flat, putting an object on the back of the monitor for example, it may cause a malfunction.

---

## Adjusting the Volume

---

Adjust the volume by turning the **Rotary encoder**.

Volume: 0 - 35

---

## Lowering Volume Quickly

---

Activating this function will instantly lower the volume level by 20 dB.

Press **MUTE** to activate the **MUTE mode**.

The audio level decreases by about 20 dB.

Pressing **MUTE** again brings the audio back to its previous level.

---

## How to view the Display

---

### Touch button operation

The display unit is equipped with tactile feedback (PULSETOUCH™).

#### **What is the tactile feedback (PULSETOUCH™) ?**

When you touch a button graphic in the display, you will feel a mild vibration and click on the display panel surface. This feedback enables you to easily identify action areas in the display.

- Be sure to touch the button lightly with the pad of your finger on the display to protect the display.
- If you touch a button and there is no reaction, remove your finger from the display once, and try again.

#### **About the expression of touch buttons in this Owner's Manual**

- Display buttons in this manual are shown in bold with [ ] (e.g. [SRC]).
- This Owner's Manual explains mainly the function of touch buttons, when a touch button and a unit button have the same function.

## Recalling the Source

Here is an example explanation for the Radio mode display on how to recall a source.

### 1 Touch [SRC] on the main screen.

The source selection screen is displayed.

#### Display example for source selection screen

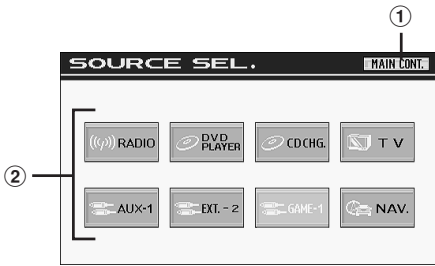

- ① Changes to main source screen
- ② Displays source modes that can be selected (The kind of source modes that are displayed varies depending on connection and setting)

### 2 Touch [RADIO].

The screen changes to the Radio mode main display.

#### Main screen example for Radio mode

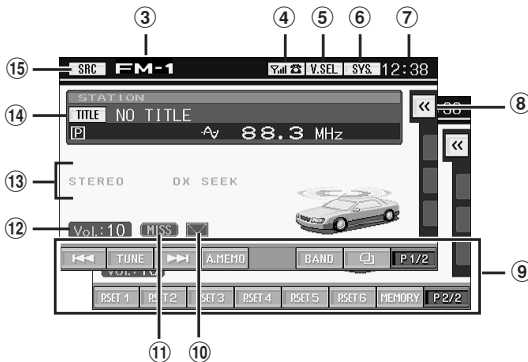

- ③ Displays the source name, such as radio band, etc., that is selected
- ④ Changes to Telephone mode\*2 (see page 55)  
Number of bars decreases depending on reception level (▼ is no reception)
- ⑤ Changes to VISUAL selection screen
- ⑥ Changes to SYSTEM selection screen
- ⑦ Displays time
- ⑧ Displays shortcut menu screen (see pages 11,12)
- ⑨ Function Guide:  
The function guide display varies depending on each source.  
The contents of the function guide change by touching [P1/2]\*1 or [P1/3]\*1 on the function guide, and many other operations can be performed.
- ⑩ Icon for new incoming mail\*2
- ⑪ Missed incoming mail icon\*2
- ⑫ Displays volume level
- ⑬ Working state indicator

- ⑭ Displays the title input screen (see pages 22,23)
- ⑮ Changes to the source selection screen (to Step 1 screen)

\*1 Display may vary depending on the connected devices.

\*2 Displayed when MobileHub (CXA-B200NK) is connected.

- When an optional DVD player or DVD changer is connected, AUX 1 appears as "EXT.DVD" or "DVD CHG" on the display.
- When both the optional DVD player and DVD changer are connected, AUX 1 appears as "EXT.DVD" and AUX 2 as "DVD CHG" on the display. (When an optional expansion box VPE-S431 is connected)
- When i-Personalize and SETUP are selected, these operations may only be carried out after the car is parked.

### 3 The screen changes to another source by touching [SRC] on the main source screen.

- The screen can be changed to the VISUAL selection screen by touching [V.SEL].
- The screen can be changed to the SYSTEM selection screen by touching [SYS].
- After 5 seconds of each operation in the visual mode, the screen changes to the visual screen only.  
To display the source selection screen, touch the display panel, then touch [MAIN CONT.] on the screen. The source selection screen appears by touching [SRC] on the changed main source screen.

## Shortcut Screen

In the main source display, shortcuts for set up of Media Xpander, Bass MAX EQ, Visual EQ, and DOLBY PLII can be shown and their settings can be made directly.

### 1 Touch [≪≪] on the far right of the main source screen.

The shortcut menu screen is displayed. (Displayed when DEFEAT is set to OFF.)

### 2 Touch a desired setup menu.

**MX (Media Xpander):**

Selects the MX mode of the currently displayed audio source.

**Bass Max EQ:**

Allows choosing any desired mode. (This function cannot be set when an external audio processor is connected. The setting can be carried out on the audio processor.)

**Visual EQ:**

Selectable when the visual source mode is turned on.

**DOLBY PLII:**

Displayed when an external audio processor is connected.

**Continued**

**Display example for shortcut menu screen**



The setup screen is displayed by touching one of these modes.



**Display example for setup screen**

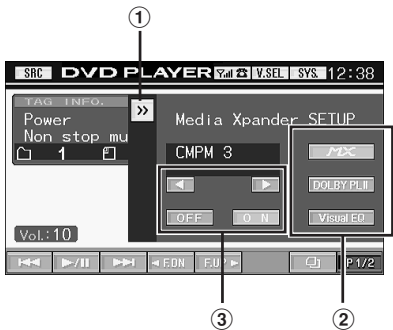

- ① Close the Shortcut menu screen by touching [➤➤].
- ② The screen changes to the setup screen mode by touching another mode.
- ③ Your desired setting can be made by using operation buttons.

**Displaying the Numeric Keypad Input Screen**

The numeric keypad input screen is displayed when the DVD mode is selected for searching a title or chapter, and for entering a country code or password for the DVD setup item, and also when selecting a channel number in the XM Radio mode.

- 1 Touch [10KEY] on the main source screen.
- 2 Touch the desired numeric key.

**Display example for numeric keypad**

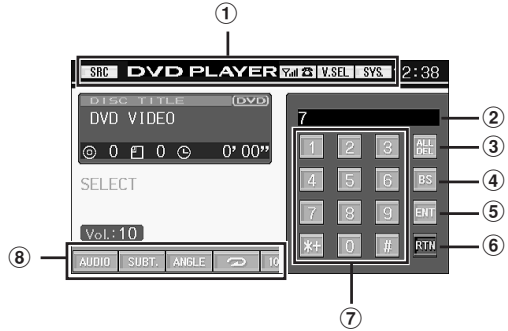

- ① Operation buttons of this area can be used while displaying the numeric keypad input screen.
- ② Input screen area
- ③ All input numbers will be deleted
- ④ Previous number will be deleted
- ⑤ Input number is confirmed
- ⑥ Closes numeric keypad input screen
- ⑦ Numeric keypad
- ⑧ Operation buttons of this area cannot be used while displaying the numeric keypad input screen.

- 3 Touch [ENT] to confirm your entry.

**Dual-Screen Display**

The connected AMP Link-compatible external amplifier can be displayed in dual-screen on the main source screen.

- 1 Touch [V.SEL] on the main source screen. The VISUAL selection screen appears.
- 2 Touch [DUAL SCREEN]. The main source screen is restored showing the dual-screen display.

**Display example for the dual-screen**

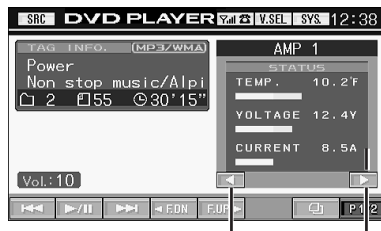

Changes the AMP display for the connected amplifier.

- 3 Touch [V.SEL] to cancel the dual-screen display. The VISUAL selection screen appears.
- 4 Touch [NORMAL]. The normal screen will be restored.

# Radio

Display example for Radio main screen



- ① [SRC] button: Refer to page 11
- ② [TITLE] button: Refer to page 22
- ③ [V.sel] button: Refer to pages 55 to 57
- ④ [V.SEL] button: Displays the VISUAL selection screen
- ⑤ [SYS.] button: Displays the SYSTEM selection screen
- ⑥ [◀◀] button: Refer to page 11
- A Displays the input radio station title.
- B Displays the preset number/frequency.

## Listening to the Radio

- 1 Touch [SRC] on the main source screen.  
The source selection screen is displayed.
  - 2 Touch [RADIO].  
The radio mode is activated and the display changes to the Radio Mode screen.
  - 3 Touch [BAND] to select the desired radio band.  
Each press changes the bands as follows:  
FM-1 → FM-2 → AM → FM-1
  - 4 Touch [TUNE] to choose the tuning mode.  
Each touch changes the tuning mode display.  
Distance → Local → Manual → Distance  

    - There are two modes you can select for auto tuning, DX and Local:
      - DX (Distance) mode (with DX SEEK indicator ON);  
Both strong and weak stations will be tuned in.
      - Local mode (with SEEK indicator ON);  
Only strong stations will be tuned in.
 The initial setting is DX.
  - 5 Touch [◀◀] or [▶▶] to change the radio frequency up or down respectively.  
When the button is touched and held, the frequency changes continuously until the button is released.
- When a stereo FM station is tuned in, the STEREO indicator appears in the display.

## Manual Storing of Station Presets

- 1 Tune in a desired radio station you wish to store in the preset memory by manual or automatic seek tuning.
- 2 Touch [P1/2] to change the function guide.
- 3 Touch [MEMORY].
- 4 Touch any one of the preset buttons [P.SET 1] through [P.SET 6] within 5 seconds.  
The selected station is stored.
- 5 Repeat the procedure to store up to 5 other stations onto the same band.  
To use this procedure for other bands, simply select the band desired and repeat the procedure.

A total of 18 stations can be stored in the preset memory (6 stations for each band; FM1, FM2 or AM).

- If a preset memory has already been set in the same preset number, it will be cleared and the new station will be memorized.

## Automatic Memory of Station Presets

The tuner can automatically seek and store 6 strong stations in the selected band in order of signal strength.

- After selecting the desired band, touch [A.MEMO].**  
The tuner automatically seeks and stores 6 strong stations into [P.SET 1] to [P.SET 6] in order of signal strength.  
When the automatic storing has been completed, the tuner goes to the station stored in [P.SET 1].
- If no stations are stored, the tuner will return to the original station you were listening to before the automatic storing procedure began.

## Tuning to Preset Stations

You can tune in the preset stations in memory on each band using the preset number.

- 1 After selecting the desired band, touch [P1/2] to change the function guide.
- 2 Touch any one of the preset buttons [P.SET 1] through [P.SET 6] that has a station stored to it.  
The preset station is received.

## Searching from Radio Station Title

If the title of a radio station is entered, a title list is displayed. (See "Titling Discs/Radio Stations" on page 22)

- 1 Touch [□] to activate the search mode.  
The screen changes to the radio title list display.
- 2 Touch [▶] to select the desired radio title.  
The screen changes to the radio mode main display, and the desired radio station is received.

# CD/MP3/WMA

Display example for MP3/WMA main screen

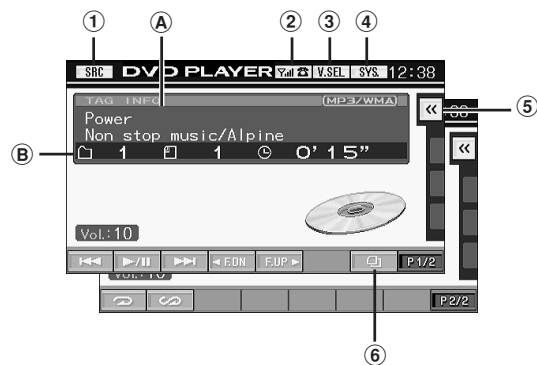

- ① [SRC] button: Refer to page 11
- ② [V.M] button: Refer to pages 55 to 57
- ③ [V.SEL] button: Displays the VISUAL selection screen
- ④ [SYS.] button: Displays the SYSTEM selection screen
- ⑤ [◀◀] button: Refer to page 11
- ⑥ [□] button: Refer to page 23

- A** CD:  
Displays track text\*1 in the upper line.  
Displays input title in the lower line.  
Disc text\*1 is displayed if there are no titles in the display.  
**MP3/WMA:**  
After displaying the file name in the upper line, the track name is displayed if there is ID3 tag information.  
After displaying the folder name, the artist name/album name are displayed if there is ID3 tag information.
- B** CD:  
Displays the track number/disc number\*2/elapsed time.  
**MP3/WMA:**  
Displays the folder number/file number/disc number\*3/elapsed playback time

\*1 Displayed when CD text is available.  
\*2 Displayed when a CD changer is connected.  
\*3 Displayed when an MP3 compatible CD changer is connected.

## Playback

- 1 Touch [SRC] on the main source screen.**  
The source selection screen is displayed.
- 2 Touch [DVD PLAYER].**  
The display shows the DVD player mode screen.  
When a CD/MP3/WMA is inserted into the DISC SLOT of the IVA-D300, with the label side facing up, the unit starts to play the CD/MP3/WMA.

- When an optional Alpine CD player is connected, inserting a CD into the optional CD player starts playback automatically.

- 3 Touch [◀◀] or [▶▶] to select the desired track (file).**

**Returning to the beginning of the current track (file):**

Touch [◀◀].

**Fast backward :**

Touch and hold [◀◀].

**Advancing to the beginning of the next track (file) :**

Touch [▶▶].

**Fast forward :**

Touch and hold [▶▶].

### To pause playback

Touch [▶||].

Touching [▶||] again will resume playback.

### To eject the disc

Press ▲.

- The IVA-D300 models include a built-in MP3/WMA unit. You can play CD-ROMs, CD-Rs, and CD-RWs containing MP3/WMA files on this unit. Use the format compliant with this unit. For further information about playing or storing MP3/WMA files, refer to pages 15 and 16 before using the unit.
- A WMA format file that is protected by DRM (Digital Rights Management) cannot be played back on this unit.
- The unit can play discs containing both audio data and MP3/WMA data.
- The MP3/WMA indicator is lit during MP3/WMA playback.
- No sound is played during fast-forwarding/fast-reversing.
- The fast-reversing operation can be performed in the MP3/WMA mode only when a track (file) is currently being played back.
- The track display for CD audio data playback is the track numbers recorded on the disc.
- Three-inch (8cm) CD's can be used.
- "Playing MP3/WMA Data" is mentioned on page 31 "GENERAL Setup".
- When an MP3/WMA disc is played, it sometimes takes a few moment until it starts.
- Touch [□] to activate the search mode. For operations, refer to "Disc Search Function" on page 23.



---

## Repeat Play

---

**Touch [↺] to play back repeatedly the track currently being played.**

The track (file) will be played repeatedly.

Touch [↺] again and select OFF to deactivate Repeat play.

CD: RPT → RPT ALL\*<sup>1</sup> → (off) → RPT

MP3/WMA:

- 1 Touch [P1/2]\*<sup>3</sup> to change the function guide.
- 2 Touch [↺] and select the desired Repeat play.

RPT → RPT FLDR\*<sup>2</sup> → RPT ALL\*<sup>1</sup> → (off) → RPT

\*<sup>1</sup> *If a CD Changer or an MP3 compatible CD changer is connected and the RPT ALL mode is selected, the unit repeatedly plays back all tracks (files) on the disc selected.*

\*<sup>2</sup> *Only files in a folder are repeatedly played back.*

\*<sup>3</sup> *Display may vary depending on the connected devices.*

---

## M.I.X. (Random Play)

---

**Touch [∞] during playback.**

The tracks (files) on the disc will be played back in a random sequence.

To cancel M.I.X. play, touch [∞].

CD: M.I.X. → M.I.X. ALL\*<sup>1</sup> → (off) → M.I.X.

MP3/WMA:

- 1 Touch [P1/2]\*<sup>4</sup> to change the function guide.
- 2 Touch [∞] and select the desired M.I.X. play.  
M.I.X. FLDR\*<sup>3</sup> → M.I.X.\*<sup>2</sup> → (off) → M.I.X. FLDR\*<sup>3</sup>

\*<sup>1</sup> *If a CD Changer equipped with the M.I.X. ALL function is connected, M.I.X. ALL will also be selectable. In this mode, the tracks on all the CDs in the current magazine will be included in the random playback sequence.*

\*<sup>2</sup> *If an MP3 compatible CD changer is connected, all files in a disc are played back in random sequence, and playback shifts to the next disc.*

\*<sup>3</sup> *Only files in a folder are played back in random sequence in the M.I.X. FLDR mode.*

\*<sup>4</sup> *Display may vary depending on the connected devices.*

---

## Selecting Folders (concerning MP3/WMA)

---

**Touch [F.DN] or [F.UP] to select the folder.**

---

## About MP3/WMA

---

### CAUTION

*Except for private use, duplicating audio data (including MP3/WMA data) or distributing, transferring, or copying it, whether for free or for a fee, without permission of the copyright holder is strictly prohibited by the Copyright Act and by international treaty.*

### What is MP3?

MP3, whose official name is "MPEG-1 Audio Layer 3," is a compression standard prescribed by the ISO, the International Standardization Organization and MPEG which is a joint activity institution of the IEC.

MP3 files contain compressed audio data. MP3 encoding is capable of compressing audio data at extremely high ratios, reducing the size of music files to as much as one-tenth their original size. This is achieved while still maintaining near CD quality. The MP3 format realizes such high compression ratios by eliminating the sounds that are either inaudible to the human ear or masked by other sounds.

### What is WMA?

WMA, or "Windows Media™ Audio," is compressed audio data. WMA allows you to create music files and store them at higher ratios of compression than MP3 audio data (approx. half original size). This is achieved while still maintaining CD quality sound.

### Method for creating MP3/WMA files

Audio data is compressed by using MP3/WMA specified software. For details on creating MP3/WMA files, refer to the user's manual for that software.

MP3/WMA files that can be played back by this device have the file extension "mp3" / "wma". Files with no extension cannot be played back. (WMA ver. 7.1 and 8 are supported)

### Supported playback sampling rates and bit rates

#### MP3

Sampling rates: 32 kHz ~ 48 kHz  
Bit rates: 32 - 320 kbps

#### WMA

Sampling rates: 32 kHz ~ 48 kHz  
Bit rates: 32 - 192 kbps

This device may not play back correctly depending on sampling rates or bit rates.

### ID3 tags/WMA tags

This device supports ID3 tag v1, and WMA tag.

If tag data is in an MP3/WMA file, this device can display the title (track title), artist name, and album name ID3 tag/WMA tag data.

This device can only display single-byte alphanumeric characters (up to 30 for ID3 tags and up to 15 for WMA tags) and the underscore. For non-supported characters, "NO SUPPORT" is displayed.

The tag information may not be correctly displayed, depending on the contents.

### Producing MP3/WMA discs

MP3/WMA files are prepared, then written to a CD-R or CD-RW using CD-R writing software. A disc can hold up to 255 files/255 folders (including Root Folders).

Depending on the structure of the folders or files, it may take time to read a disc. In this case, it is recommended to decrease the number of folders or files.

### Media supported

The media that this device can play back are CD-ROMs, CD-Rs and CD-RWs.

## Terminology

### **Bit rate**

*This is the “sound” compression rate specified for encoding. The higher the bit rate, the higher the sound quality, but also the larger the files.*

### **Sampling rate**

*This value shows how many times per second the data is sampled (recorded). For example, music CDs use a sampling rate of 44.1 kHz, so the sound is sampled (recorded) 44,100 times per second. The higher the sampling rate, the higher the sound quality, but also the larger the volume of data.*

### **Encoding**

*Converting music CDs, WAVE (AIFF) files, and other sound files into the specified audio compression format.*

### **Tag**

*Song information such as track titles, artist names, album names, 4879 7 265.04 5*

# DVD/Video CD

## Display example for DVD main screen

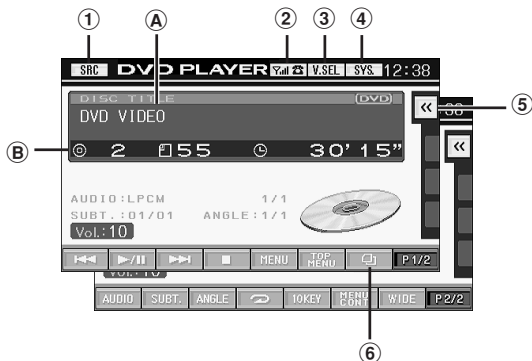

- ① [SRC] button: Refer to page 11
  - ② [VSEL] button: Refer to pages 55 to 57
  - ③ [VSEL] button: Displays the VISUAL selection screen
  - ④ [SYS.] button: Displays the SYSTEM selection screen
  - ⑤ [P1/2] button: Refer to page 11
  - ⑥ [P2/2] button: Refer to page 23
  - A Displays the input title only for video CD.
  - B Displays the title number/chapter number/elapsed playback time for a DVD.  
Displays the track number/elapsed playback time for a video CD.
- Some operations cannot be carried out depending on the disc or playback screen.
  - Displays of the function guide [P1/2], etc., may vary depending on the connected device(s).

## Playing DVD/Video CD

IVA-D300 has a built-in DVD player. When an optional Alpine DVD/video CD/CD player (or DVD changer) is connected to the IVA-D300, you can control it from the IVA-D300. (except some operations)

### ⚠ WARNING

It is dangerous (and illegal in many states) for the driver to watch the DVD/TV/Video while driving the vehicle. The driver may be distracted from looking ahead and an accident could occur.

Install the IVA-D300 correctly so that the driver cannot watch DVD/TV/Video unless the vehicle is stopped and the emergency brake is applied.

If the IVA-D300 is not installed correctly, the driver will be able to watch the DVD/TV/Video while driving the vehicle and may be distracted from looking ahead causing an accident. The driver or other people could be severely injured.

## To display the DVD mode screen

To watch a video source, your vehicle must be parked with the ignition key in the ACC or ON position. To do this, follow the procedure below.

1. Push the foot brake to bring your vehicle to a complete stop at a safe location. Engage the parking brake.
2. Keep pushing the foot brake and release the parking brake once then engage it again.
3. While the parking brake is being engaged the second time, release the foot brake.

- For automatic transmission vehicles, place the transmission lever in the Park position.

Now, the locking system for the DVD mode operation has been released. Engaging the parking brake can reactivate the DVD mode, as long as the car's ignition has not been turned off. It is not necessary to repeat the above procedure (1 through 3), of "To display the DVD mode screen."

Each time the ignition is turned OFF, perform the procedure of "To display the DVD mode screen."

- If you try to activate the auxiliary device while driving, the display will show the warning-PICTURE OFF FOR YOUR SAFETY.

### ⚠ Caution

- Not all functions will operate for every DVD. See the individual DVD's instructions for details on the features supported.
- Fingerprints on a disc may adversely affect playback. If a problem occurs, remove the disc and check for fingerprints on the playback side. Clean the disc if necessary.
- If you switch the power or Ignition Key OFF or change sources during playback, playback will continue where you left off when you resume playback.
- If you try to perform an invalid operation (based on the type of disc being played), the following mark is displayed on the monitor screen: Ⓞ

### • Play Position Memory Function

Even if you turn power off or switch the Ignition Key to OFF during playback or change the source, playback will continue from the point where playback stopped when the power is turned ON again.

## 1 Touch [SRC] on the main source screen.

The source selection screen is displayed.

## 2 Touch [DVD PLAYER].

The display shows the DVD player mode screen.

Insert a disc into the DVD/video CD/CD player. The unit starts to play the disc.

When an optional Alpine DVD player is connected:  
Insert a disc into the DVD/video CD/CD player, the player starts playing.

- The operation screen changes to the visual screen in the DVD or video CD mode for 5 seconds after an operation has been performed. Touch the display panel to display the operation screen again.
- The display mode can be changed by touching [WIDE]. For operation, see "Switching Display Modes" on page 24.

### To eject the disc

Press ▲.

- The reverse side of a double-sided DVD will not be played automatically.  
Remove the disc, turn it over, and reinsert it.
- DO NOT insert discs containing maps for the navigation system. Doing so could result in damage.
- Refer also to "DVD Setup" (pages 27 to 30).
- If ► (playback symbol) is displayed when a video CD with PBC (Playback Control) is inserted, playback is enabled by touching and holding [►/⏮] for at least 2 seconds.
- Be sure the remote input lead is connected to the remote output lead of this unit when a DVD changer or DVD player is connected. If not correctly connected, touch operation cannot be performed.
- To return to the previous screen during video CD playback, touch [◀] after touching [P1/2] of the function guide. However, the function may vary depending on the disc.

### If a menu screen appears

On DVDs and Video CDs with playback control (PBC), menu screens may appear automatically. If this happens, perform the operation described below to start playback.

#### Direct Menu Operations (DVD only)

- 1 Touch the DVD menu directly.

- Some operations cannot be performed depending on the disc.

#### Menu Operations (DVD only)

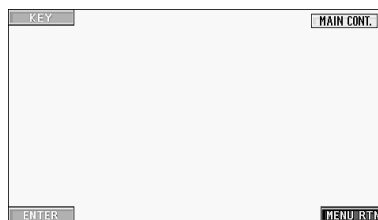

- 1 Touch [KEY].  
The menu operation mode will be displayed.

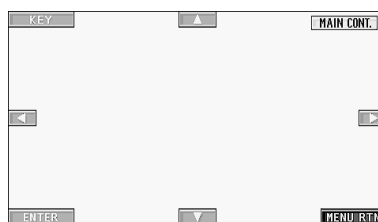

- 2 Select a desired menu item by touching [▲], [▼], [◀] or [▶].
- 3 Touch [ENTER] to confirm the selected item.

## Numeric Keypad Input Operations (DVD)

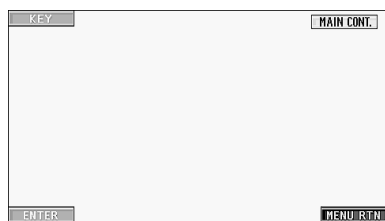

- 1 Touch [KEY].  
The menu operation mode appears
- 2 Touch [KEY] again.  
The numeric keypad input mode screen appears.

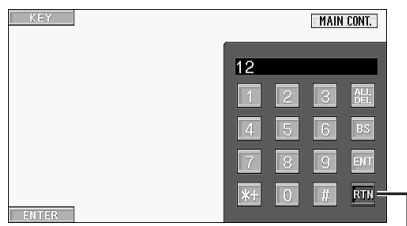

Touch [RTN] to close the numeric keypad input screen.

- 3 Touch a desired number.
- 4 Touch [ENT] on the numeric keypad mode screen to confirm your selection.

## Numeric Keypad Input Operations (Video CD)

When PBC is turned OFF, the menu screen is not displayed. Turn it ON to display the screen (see "Turning the PBC Function ON or OFF" on this page).

- 1 Touch [P1/2] in the video CD mode to change the function guide.
- 2 Touch [10KEY].  
The numeric keypad is displayed.
- 3 Touch and input a desired number.
- 4 Touch [ENT] to confirm.

## Displaying the Top Menu Screen (DVD only)

When a DVD contains two or more titles, the top menu screen appears.

### Touch [TOP MENU] on the DVD mode main screen.

The top menu screen appears.

- To perform necessary operations, see "If a menu screen appears" on pages 18 and 19.

## Displaying the Menu Screen (DVD only)

With a DVD having two or more menus, a menu screen will appear for the programs available, in addition to the main programs.

### Touch [MENU] on the DVD mode main screen.

The menu screen appears.

- To perform necessary operations, see "If a menu screen appears" on pages 18 and 19.

## Displaying the Menu Operation Mode Screen (DVD only)

- 1 Touch [P1/2] on the DVD mode main screen.  
The function guide changes.
- 2 Touch [MENU CONT].  
The menu operation mode screen appears.

- For further operation, see "If a menu screen appears" on pages 18 and 19.

## Turning the PBC Function ON or OFF (Video CD only)

The following describes how to turn a video CD equipped PBC (playback control) on or off.

### Touch [PBC] on the video CD mode main screen.

Touching [PBC] sequentially turns the PBC on and off.

## Stopping Playback (PRE STOP)

Press the stop button during playback to stop playback. That position is stored in the memory.

- 1 Touch [■] once during playback.  
"PRE STOP" is displayed.
- 2 Touch [▶/II] in the PRE STOP mode.  
Playback starts from the position at which it was stopped.

- For some discs, the position at which playback was stopped may not be accurate.

## Stopping Playback

### Touch [■] twice or touch and hold [■] for at least 2 seconds during playback.

"STOP" is displayed, and playback stops.

- Playback starts from the beginning when [▶/II] is touched while playback is stopped.

## Fast-forwarding/Fast-reversing

- 1 During playback, touch [◀◀] (Fast-reverse) or [▶▶] (fast-forward).

When touched and held for more than 1 second, the disc is forwarded/reversed at double speed. When held for 5 more seconds or longer, the disc is forwarded/reversed at 8 times the normal speed.

- 2 Stop touching [◀◀] or [▶▶] to return to normal playback.

- No sound is played during fast-forwarding/fast-reversing.
- No subtitles are shown during fast-forwarding/fast-reversing. However, subtitles may be displayed depending on the disc.
- For DVDs and video CDs with playback control (PBC), the menu screen may reappear during fast-forwarding/fast-reversing.

## Finding the Beginnings of Chapters or Tracks

### During playback, touch [◀◀] or [▶▶].

The chapter/track switches each time the button is touched, and playback of the selected chapter/track starts.

- ▶▶: Touch this to start playback from the beginning of the following chapter or track.
- ◀◀: Touch this to start playback from the beginning of the current chapter or track.

- Some DVDs do not have chapters.

#### Supplementary explanation

"Chapters" are divisions of movies or musical selections on DVDs.

"Tracks" are divisions of movies or musical selections on video and music CDs.

## Playing Still Frames (Pausing)

### 1 During playback, touch [▶/II].

### 2 Touch [▶/II] to resume playback.

- No sound is played during the still frame mode.
- The image or sound may stop temporarily when playback starts from the pause mode. This is not a malfunction.

## Frame-by-frame Playback

### 1 In the pause mode, touch [▶▶].

The picture advances by one frame each time the button is touched.

### 2 Touch [▶/II] to return to normal mode.

- No sound is played during frame-by-frame playback.

## Slow Motion Playback

### 1 When [▶▶] is touched and held while in the pause mode, the 1/8th speed slow motion playback mode is set.

When held in for 5 more seconds, the slow motion speed switches to 1/2 the normal speed.

### 2 Stop touching [▶▶] to pause, and touch [▶/II] to playback.

- No sound is played during slow motion playback.
- Reverse slow motion playback is not available.
- 1/2, 1/8 are approximate speeds. The actual speed differs from disc to disc.

## Chapter/Track/Title Repeat Playback

Use this function to play the disc's titles, chapters or tracks repeatedly.

### DVD

### 1 During playback, touch [P1/2].

### 2 Touch [↺] on the main unit.

The repeat mode switches every time the button is touched.

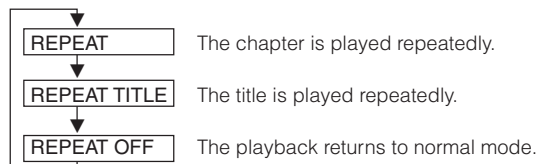

The chapter is played repeatedly.

The title is played repeatedly.

The playback returns to normal mode.

- Display may vary depending on the connected devices.

### Video CD

### 1 During playback, touch [P1/2].

### 2 During playback, touch [↺] on the main unit.

The repeat mode switches every time the button is touched.

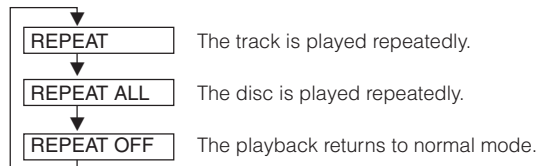

The track is played repeatedly.

The disc is played repeatedly.

The playback returns to normal mode.

- Display may vary depending on the connected devices.
- The track/disc repeat modes cannot be used on video CDs with playback control (PBC). These modes can be carried out after turning PBC off. See "Turning the PBC Function ON or OFF" on page 19.
- For some discs it is not possible to switch the repeat mode.
- Step 1 is not necessary when a DVD changer or DVD player is connected.

## Searching by Title Number (DVD only)

Use this function to easily find positions on the DVD using the DVD's titles.

### 1 Touch [P1/2] while playback is stopped.

The function guide appears.

### 2 Touch [10KEY].

The numeric keypad input mode screen appears.

### 3 Enter a desired title by touching its title number.

See page 19 for operation of the numeric keypad.

### 4 Confirm your selection by touching [ENT].

Playback will start from the title number selected.

- This function cannot be used on discs on which no title numbers are recorded.
- Playback starts from the beginning of the chapter/track number in the state of PRE STOP.
- Some disc may not accept any operation.

---

## Searching Directly by Chapter or Track Number

---

Use this function to easily move to the beginnings of the chapters or tracks on the disc.

- 1 Touch [P1/2] in any mode other than stop mode.**  
The function guide will appear.
- 2 Touch [10KEY].**  
The numeric keypad input mode screen will appear.
- 3 Touch and enter the chapter or track number you want to play.**  
See page 19 for operation of the numeric keypad.
- 4 Touch [ENT] to confirm your selection.**  
Playback will start from the selected chapter or track.
  - *This function is not available for a disc on which chapters or tracks are not stored.*
  - *Direct search of a track number is not available for a video CD with the PBC (playback control) function as long as its PBC is turned on. Be sure to turn PBC off before starting the search (see "Turning the PBC function ON or OFF" on page 19).*

---

## Switching the Angle (DVD only)

---

On DVDs in which scenes have been filmed from multiple angles, the angle can be switched during playback.

- 1 During playback, touch [P1/2].**  
The function guide changes.
- 2 Touch [ANGLE].**  
The angle switches between the angles recorded on the disc every time the button is touched.
  - *Some time may be required for the angle to change.*
  - *Depending on the disc, the angle may switch in one of two ways.*
    - *Seamless: The angle switches smoothly.*
    - *Non-seamless: When the angle is switched, a still picture is displayed first, after which the angle switches.*

---

## Switching the Audio Tracks

---

DVDs can have up to 8 different audio tracks. These alternate tracks can be switched during playback.

- 1 During playback, touch [P1/2].**
- 2 Touch [AUDIO].**  
The sound switches between the alternate audio tracks recorded on the disc every time the button is touched.
  - *The alternate track selected becomes the default setting every time the power is turned on or the disc is replaced. If the disc does not include that track, the disc's default language is selected instead.*
  - *Not all discs will allow changing the alternate audio tracks during playback. In these cases, select audio tracks from the DVDs menu.*
  - *There may be a delay before the selected alternate track begins to play.*

---

## Video CDs with multiplex audio

---

- 1 During playback, touch [P1/2].**  
The function guide changes.
- 2 Touch [AUDIO].**  
The left and right channels will be output as shown in the figure below, each time the button is pressed.  
AUDIO L/L → AUDIO R/R → AUDIO L/R → AUDIO L/L

---

## Switching the Subtitles (Subtitle Language) (DVD only)

---

With DVDs on which multiple subtitle languages are recorded, the subtitle language can be switched during playback; moreover, subtitles can be hidden.

- 1 During playback, touch [P1/2].**  
The function guide changes.
- 2 Touch [SUBT.].**  
Touching this button repeatedly selects sequentially the subtitle languages recorded on the disc, and then turns the subtitles OFF.
  - *There may be a delay before the selected subtitle appears.*
  - *Not all discs will allow changing the subtitles during playback. In these cases, select subtitles from the DVDs menu.*
  - *The subtitle language selected becomes the default setting every time the power is turned on or the disc is replaced. If the disc does not include that language, the disc's default language is selected instead.*
  - *For some discs, the subtitles will be displayed even when this is set to off.*

---

## Switching from the disc menu

---

For some discs, the audio language, angle and subtitles can be switched from the disc menu.

- 1 Touch [MENU] or [TOP MENU] to display the menu.**
- 2 Select an item to confirm it.**  
See "If a menu screen appears" on pages 18 and 19.

---

## Displaying the Disc Status for DVD/Video CD

---

Use the procedure described below to display the status (title number, chapter number, etc.) of the currently playing DVD or of the currently playing video CD (track number, etc.) on the monitor.

- 1 During playback, touch the display panel.**  
The operation menu screen is displayed.
- 2 Touch [MAIN CONT.] within 5 seconds.**  
The display status is displayed for 5 seconds.

# Other Useful Features

## Adjusting the Audio

Press the **Rotary encoder** on the unit.

The display changes to the Audio Adjustment screen.

*Display Example for Audio Adjustment Screen*

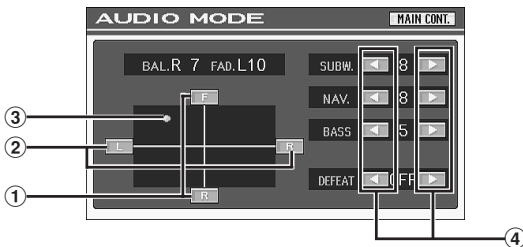

- ① Adjust the volume of the front and rear speakers by touching [F] or [R].
- ② Adjust the volume of the left and right speakers by touching [L] or [R].
- ③ Determine your desired setting value by touching and moving [O].
- ④ Touches [◀, ▶] to adjust to your preference.

- Touch [AUDIO MODE] on the SYSTEM selection screen to change to the Audio Adjustment screen.

### Adjusting the Balance

Touch [L] or [R] to adjust the sound volume of the left and right speakers.

Setting range: L15 to R15

### Adjusting the Fader

Touch [F] or [R] to adjust the volume of the front and rear speakers.

Setting range: F15 to R15

### Adjusting the Subwoofer Level

Touch [◀] or [▶] of SUBW. to adjust the subwoofer output.

Setting range: 0 to 15

- The level adjustment becomes available when 0° or 180° is set in "Subwoofer On and Off" (page 40).

### Adjusting NAV. LEVEL

Touch [◀] or [▶] of NAV. to adjust the volume of navigation interruption.

Setting range: 0 to 15

- This adjustment becomes available when NAV.MIX is turned on in "Setting the Navigation Interruption" (page 32).

### Turning defeat ON or OFF

Touch [◀] or [▶] of DEFEAT to turn it ON or OFF.

If you set the defeat to ON, MX is turned OFF and EQ is returned to the initial setting.

### Adjusting the BASS Level

Touch [◀] or [▶] of BASS to adjust the low frequency bass level.

Setting range: 0 to 11

- This adjustment becomes available when AMP Link compatible external amplifiers (MRD-M301 and MRD-M501) are connected.

### Adjusting the Balance/Fader Directly

Touch and move [O] to a desired setting.

Or touch a desired setting range, and [O] will move to that location.

Touch [L] or [R] of Balance and [F] or [R] of Fader for fine-tuning.

## Titling Discs/Radio Stations

### To display the Title Inputting screen:

To watch a video source, your vehicle must be parked with the ignition key in the ACC or ON position. To do this, follow the procedure below.

1. Bring your vehicle to a complete stop at a safe location. Engage the parking brake.
2. Keep pushing the foot brake and release the parking brake once then engage it again.
3. When the parking brake is engaged for the second time, release the foot brake.

- For automatic transmission vehicles, place the transmission lever in the Park position.

Now, the locking system for the Title Inputting mode operation has been released. Engaging the parking brake can reactivate the Title Inputting mode, as long as the car's ignition has not been turned off. It is not necessary to repeat the above procedure (1 through 3), of "To display the Title Inputting mode screen." Each time the ignition is turned OFF, perform the procedure of "To display the Title Inputting mode screen."

- Trying to access this screen while driving will display the warning-CAN'T OPERATE WHILE DRIVING.

You can title radio stations and Discs (CD, Video CD). This manual describes how to title radio stations.

(You cannot title DVD and MP3/WMA discs.)

**1** Activate the Radio mode.

**2** Touch [TITLE] on the radio main screen.  
The title input screen appears.

**3** Touch a desired character symbol to input. Up to 16 digits can be input.

Each time [A/a/1/+] is touched, alphabet upper case, lower case, numerical and then symbols are selected.



### Display example for title input screen

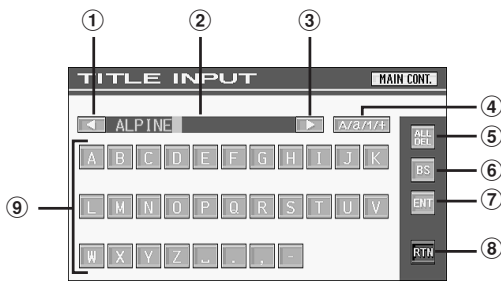

- ① Moves the cursor to the left in the input area
- ② Input area
- ③ Moves the cursor to the right in the input area
- ④ Changes between character and symbol
- ⑤ All you have input is deleted
- ⑥ Deletes a previous character
- ⑦ Confirms and stores a title you have input
- ⑧ Returns to a previous screen
- ⑨ Character/Symbol Pallet

### 4 Touch [ENT] to confirm the input title.

The display changes to the radio mode.

- You can enter up to 100 titles of radio stations, CD and video CD.
- You cannot enter file name, folder name and tag information on MP3/WMA files on this unit.
- When the memory is full, "Full Data" is displayed for 2 seconds. At this point, touch [ENT] to delete the oldest title you have input first, and then you can input a new one.
- Immediately after inputting titles or changing the settings of Setup mode or Display mode (while the system is inputting the titles or data automatically) do not turn the ignition key (engine key) to OFF. Otherwise, the title may not be written, or the settings may not be changed.

## Disc Search Function

### 1 Touch [ ] on the function guide while in the disc mode.

The disc search mode is turned on, and the disc search list screen is displayed.

#### Select a desired disc title.

Touch [▶] for direct playback.

When a hierarchical list is prepared for the disc, [◀] or [▶] will be displayed. Touch [▶] to display the respective hierarchy list screens (to respective modes described in Step 2).

### Display Example for Disc Search Screen

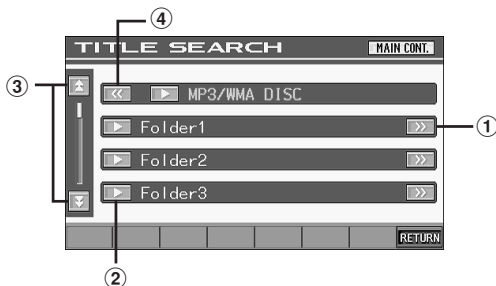

- ① [▶] is displayed if there is a hierarchical list.
- ② Select directly by touching [▶], and its disc (or folder/file) is played back.
- ③ Go through the list pages by touching [▲] or [▼].
- ④ Touch [◀] to return to the previous list screen\*.

\* This screen displays a list of the disc currently playing, or each disc of a connected external CD player or changer.

- When a disc title is not given to a CD or video CD, "NO TITLE" is displayed.

### 2 Touch [▶] of the selected disc title.

Another hierarchical list appears.

Refer to the following mode procedure.

#### Internal CD player mode

- 1 The track title list\* or the track list screen appears.

\* If the CD is text compatible

- 2 Touch [▶] of a desired track text\* or track.  
The selected track will be played back.

#### Internal MP3/WMA Player/external MP3-compatible Changer Mode

- 1 The folder list screen appears.  
Select a desired folder and then touch [▶].  
([▶] appears only when a file is present in the selected folder.)  
The file list screen is displayed.
  - Touch [▶] to play back the folder directly.
- 2 Touch [▶] of a desired file name.  
The selected file will be played back.

## Rear Entertainment Function

The rear entertainment function independently routes different sources to the front and the rear inside a car. For example, while listening to the radio or other audio source in the front, DVD can be enjoyed in the rear with the optional rear monitor and headphones.

### 1 Touch [SYS.] on the main source screen.

The SYSTEM selection screen is displayed.

### 2 Touch [REAR SELECT].

Rear Select display appears.

- This function cannot be used when MONITOR OUT 1 or 2 is set to OFF in the SYSTEM SETUP.

### 3 Touch your desired source (the auxiliary input or built-in DVD) to select.

REAR.1:

External monitor which is connected to AUX OUT of the tuner box on this unit. (If the optional expansion box (VPE-S431) is not connected), or an external monitor is connected to AUX OUT1 of the optional expansion box (VPE-S431).

REAR.2\*:

External monitor which is connected to AUX OUT2 of the optional expansion box (VPE-S431)

- \* REAR.2 is not displayed if only an external monitor is connected. The setting screen is displayed for REAR.2 if the external monitor is connected to the optional expansion box (VPE-S431).

- Touch [OFF] to cancel the rear entertainment function.
- When the "Setting the AUX Mode" (page 33) is set to OFF, the auxiliary source is not displayed.
- When TV is selected in AUX IN 1, 2 MODE, TV is displayed.

Continued

## Switching the function of the remote sensor

For optional remote control operation, the remote sensor of the external device (monitor, etc.) can be switched, as you prefer.

### 4 Touch [FRONT], [REAR 1] or [REAR 2].

The monitor which has a priority to the remote control operation is changed.

**FRONT:** The remote sensor of this unit is effective.

**REAR1:** The remote sensor of the external monitor connected to AUX OUT of the tuner box of this unit, or the optional expansion box (VPE-S431) is effective, and the remote control can operate only the source selected for the terminals.

**REAR2:** The remote sensor of the external monitor connected to AUX OUT of the optional expansion box (VPE-S431) is effective, and the remote control can operate only the source selected for the terminals.

- When you watch the built-in DVD in IVA-D300 (front monitor) and in the rear monitor, the On Screen display of the rear monitor (PLAY, PAUSE, FAST FWD, etc.) is not displayed.
- The sensor of the touch panel rear monitor has priority over the sensor of the remote control, if the rear monitor (connected to the Alpine touch panel rear monitor via the Monitor control lead) is touched, regardless of the remote control sensor switch setting. Note, however, that the sensor of the remote control that has been set takes priority if it has been 5 seconds since last touching the panel.
- When an optional DVD changer or DVD player is connected, and the remote control sensor is set to REAR1 or REAR2, some touch button operations ( [STOP] STOP, etc.) cannot be performed. In this case, set the remote control sensor to FRONT.

## Switching Display Modes

After carrying out the steps 1 to 3 of “To display the DVD mode Screen” explained on page 27, perform the operation described below.

**While your vehicle is parked, touch [WIDE] on the visual source screen.**

Each touch changes the display modes as follows:

MODE 1 → MODE 2 → MODE 3 → MODE 4 → MODE 1  
(WIDE) (ZOOM) (CINEMA) (NORMAL) (WIDE)

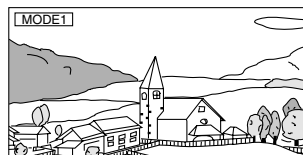

In Mode 1 (Wide), the monitor displays a normal picture wider to fit in a wide-screen monitor by evenly stretching out the picture horizontally.

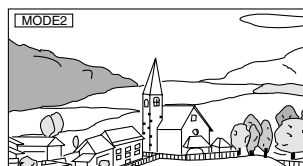

In the Mode 2 (Zoom), the monitor displays a normal picture wider to fit in the wide-screen monitor by unevenly stretching out. The centre portion of the picture is stretched out only slightly in order to make the important centre portion of the picture look natural.

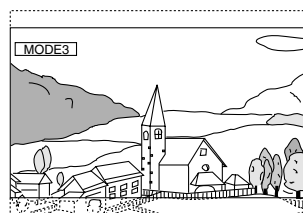

In Mode 3 (Cinema), the monitor displays a normal picture by stretching out the picture horizontally and vertically. This mode is good for displaying a cinema type picture at the 16:9 ratio.

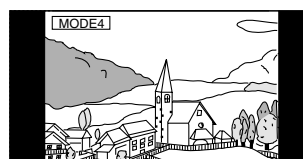

In Mode 4 (Normal), the monitor displays a normal picture at the center of the screen with a vertical black band at each side.

---

## Switching the Visual Source Only (Simultaneous Function)

---

You can watch the video portion of another source while listening to the current source.

- After carrying out the steps 1 to 3 of “To display the DVD mode Screen” explained on page 27, perform the operation described below.

- 1 Touch [V.SEL] on the audio source screen.**  
The VISUAL selection screen appears.
- 2 Touch a desired visual source.**  
The visual source is switched to the selected one.

### Canceling the Simultaneous Function

- 1 Press V.SEL.**  
The VISUAL selection screen appears.
- 2 Touch [NORMAL].**  
The simultaneous function is canceled.

- 
- 1 Touch the visual screen to display the main control.**
  - 2 Touch [MAIN CONT.].**
  - 3 Touch [V.SEL] within 5 seconds.**  
The VISUAL selection screen appears.
  - 4 Touch [NORMAL].**  
The simultaneous function is canceled.

- If a DVD player is connected, you can receive the DVD picture/sound.  
DVD player (DVA-5205) or DVD changer (DHA-S680) is connected:  
Press and hold **V.OUT** on the remote control supplied with the DVD player or DVD changer for more than 2 seconds. The picture and sound of the DVD will be output.  
The DVA-5210 is connected:  
Press **V.OUT** on the remote control (included with the DVA-5210) to output DVD picture/sound.
- The simultaneous function cannot be used when the Audio source is in the navigation mode.
- By pressing **V.SEL** for more than 2 seconds, the simultaneous function is canceled.

---

## Blackout Mode On and Off

---

When Blackout mode is turned on, the display will turn off to reduce power consumption.

This additional power enhances the sound quality.

- 1 Touch [V.SEL] on the main source screen.**  
The VISUAL selection screen is displayed.
- 2 Touch [OFF].**  
The backlit-display portion goes out.
- 3 Touch [OFF] again to cancel the display backlight.**

- If any button on the unit is pressed during Blackout mode, the function will be displayed for 5 seconds to show the operation before returning to Blackout mode.

---

## Setting VISUALIZER

---

This setting is available when the expansion box (VPE-S431) is connected.

- 1 Touch [V.SEL] on the main source screen.**  
The VISUAL selection screen is displayed.
- 2 Touch [VISUALIZER].**  
The Visualizer setting screen is displayed. If you do not touch any button for 5 seconds, the operating display buttons, [MAIN CONT.] etc., will disappear.
- 3 Touch the screen (visual screen only) after the operating display has disappeared.**  
The VISUALIZER setup mode is displayed.
- 4 Select a desired mode by touching [◀] or [▶] of VISUALIZER within 5 seconds.**

MODE1 to MODE6 / OFF:

Recalls the maker's setting mode on the expansion box (VPE-S431).

SCAN: Displays the pattern of MODE1 to MODE6 repeatedly.

### Canceling the Visualizer Function:

Touch [NORMAL] on the VISUAL selection screen.

- This setting is enabled when OFF is selected for “Setting the Visual Effect” (this page) and ON is selected for “Connecting and Setting the External Expansion Box”, “Setting the VISUALIZER Mode Display” (page 33).

---

## Setting the Visual Effect

---

This setting becomes available when the expansion box (VPE-S431) is connected.

- 1 Touch [V.SEL] on the visual main source screen.**  
The VISUAL selection screen is displayed.
- 2 Touch [VISUALIZER].**  
The Visualizer setting screen is displayed. If you do not touch any button for 5 seconds, the operating display buttons, [MAIN CONT.] etc., will disappear.
- 3 Touch the screen (visual screen only) after the operation display has disappeared.**  
The VISUALIZER setup screen appears.
- 4 Select “ON” by touching [◀] or [▶] of V.EFFECT within 5 seconds.**

ON: Turns on the function for enhancing visual effects when connected to two or more external monitors.

Set to OFF to cancel.

- V.EFFECT is not displayed when the audio main source is selected.
- When the visual effect is set to ON, the rear monitor source cannot be changed from the unit.
- This setting may not be performed while driving.

# Monitor Setting

## Monitor Setting Operation

Following Steps 1 to 4 describe the common procedures for operating the MONITOR setting function. For details of the setting function items, refer to descriptions of respective items.

### 1 Touch [SYS.] on the main source screen.

The SYSTEM selection screen is displayed.

### 2 Touch [MONITOR].

The MONITOR screen appears.

### 3 Touch [◀] or [▶] of the desired item to change its setting.

#### Setting items:

TILT / SLIDE / MONITOR O/C (OPEN/CLOSE)

### 4 Touch [RETURN] to return to the previous screen.

Touch [MAIN CONT.] to return to the main source screen that was displayed before the setup operation was started.

## Adjusting the Monitor Angle

Adjust the monitor's angle (between 40 and 105 degrees) for optimum visibility.

#### Setting item: TILT

#### Setting range: 1 to 10

- If the monitor touches an obstacle, remove the obstacle.
- The screen color will vary when viewed at certain angles. Adjust the screen angle for the best viewing position.
- If the voltage of the vehicle's battery power is low, the screen may blink when the screen angle is changed. This is not a malfunction.

## Selecting the Monitor Position

The monitor can be set in 2 positions.

#### Setting item: SLIDE

#### Setting content: BACK / FRONT

BACK: Slides the display backwards.

FRONT: Slides the display forwards

- If the monitor is forcibly pushed or pulled, you may not be able to set the monitor angle or position. In this case, press OPEN for more than 2 seconds to close the monitor once, and then open the monitor again.

## Setting Automatic Opening/Closing of the Monitor

Setting item: MONITOR O/C (OPEN / CLOSE)

Setting content: MANUAL / FULL / CLOSE

MANUAL: The monitor is manually opened or closed by pressing OPEN.

FULL: The monitor automatically opens and closes when the ignition key is turned to the "ACC" or "ON" position.

CLOSE: The monitor automatically closes when the ignition key is turned OFF.

# Setup

## DVD Setup

### DVD Setup Operation

#### To display the DVD mode screen:

To watch a video source, your vehicle must be parked with the ignition key in the ACC or ON position. To do this, follow the procedure below.

1. Bring your vehicle to a complete stop at a safe location. Engage the parking brake.
2. Keep pushing the foot brake and release the parking brake once then engage it again.
3. When the parking brake is engaged for the second time, release the foot brake.

- For automatic transmission vehicles, place the transmission lever in the Park position.

Now, the locking system for the DVD mode operation has been released. Engaging the parking brake can reactivate the DVD mode, as long as the car's ignition has not been turned off. It is not necessary to repeat the above procedure (1 through 3), of "To display the DVD mode screen."

Each time the ignition is turned OFF, perform the procedure of "To display the DVD mode screen."

*The DVD Setup operation can be carried out after removing the disc from the unit.*

The following steps 1 to 5 are common operations to each "Setting item" of DVD Setup. Refer to each section for details.

- 1 Touch [SYS.] on the main source screen.**  
The SYSTEM selection screen is displayed.
- 2 Touch [SETUP].**  
The SETUP screen appears.
- 3 Touch [>>] of DVD SETUP.**  
The DVD setup screen appears.
- 4 Touch [◀] or [▶] of the desired item to change its setting.**

#### Setting items:

MENU LANGUAGE / AUDIO LANGUAGE / SUBT. LANGUAGE / COUNTRY CODE / PARENTAL / DIGITAL OUT MODE / OPTICAL OUT / TV SCREEN

#### Display example for DVD setup screen

Touch [◀] or [▶] to set a desired language.

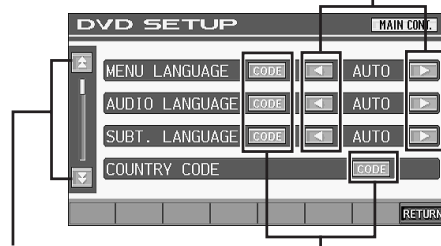

Touch [▲] or [▼] to turn pages of setting items.

Touch [CODE] to display the numeric keypad screen.

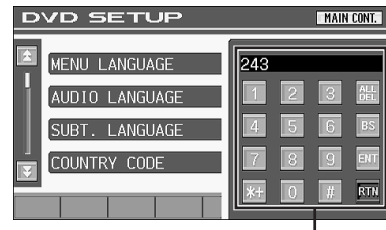

#### Numeric keypad input screen

The numeric keypad is used if you want to play back in a language other than that displayed, or to input your parental lock password, etc.

#### 5 Touch [RETURN] to return to the previous screen.

Touch [MAIN CONT.] to return to the main source screen that was displayed before the setup operation was started.

- Immediately after inputting titles or changing the settings of DVD mode (while the system is inputting the titles or data automatically) do not turn the ignition key (engine key) to OFF. Otherwise, a title may not be written, or the settings may not be changed.

#### Changing the language setting

The audio language, subtitle language and menu language can be set according to your preferences.

Once set, this becomes the default language. This function is convenient when you always want to listen in English. (The language setting is not effective on some discs. If not, the default language is set from the factory.)

- When the settings are changed, the old settings are overwritten. Make a note of the current settings before making changes. The settings are not cleared even when the vehicle's battery is disconnected.
- To temporarily change the language of the current disc, either do so from the DVD menu or by using the operation described in the section "Switching the Audio Tracks" (page 21).
- If the disc does not include the selected language, the disc's default language is set.

**Continued**

## Setting of the Menu Language

Set the language used for the menus (title menu, etc.).

**Setting item:** MENU LANGUAGE

**Setting contents:** AUTO / ENGLISH / GERMAN / FRENCH / JAPANESE / CODE

- When "AUTO" is selected, the primary menu language among the recorded ones is played.

## Setting of the Audio Language

Set the audio language produced from the speakers.

**Setting item:** AUDIO LANGUAGE

**Setting contents:** AUTO/ ENGLISH / GERMAN / FRENCH / JAPANESE / CODE

- When "AUTO" is selected, the primary audio language among the recorded ones is played.

## Setting of the Subtitle Language

Set the language of the subtitles displayed on the screen.

**Setting item:** SUBT. LANGUAGE

**Setting contents:** AUTO / ENGLISH / GERMAN / FRENCH / JAPANESE / CODE

- When "AUTO" is selected, the primary subtitle language among the recorded ones is played.

**To play in a language other than those displayed**

- 1 Touch [CODE].  
The numeric keypad screen is displayed.
- 2 Touch the 4-digit numeral of the language number.  
As for the language number, refer to "List of Language codes" (page 59).
- 3 Touch [ENT] to memorize the number.

## Changing the Country Code Setting

Set the country code when setting the rating level (Parental lock).

**Setting item:** COUNTRY CODE

**Setting content:** CODE

- When the settings are changed, the old settings are overwritten. Make a note of the current settings before making changes. The settings are not cleared even when the vehicle's battery is disconnected.

- 1 Touch [CODE].
- 2 Touch [ALL DEL] or [BS].  
Delete the displayed country number.
- 3 Touch the 4-digit country code.  
As for the country number, refer to "List of Country Codes" (pages 60, 61).
- 4 Touch [ENT] to memorize the code.

## Setting the Rating Level (Parental Lock)

This function can help restrict the viewing of movies to children of appropriate age levels only.

**Setting item:** PARENTAL

**Setting content:** INPUT

- When the settings are changed, the old settings are overwritten. Make a note of the current settings before making changes. Then settings are not cleared even when the vehicle's battery is disconnected.
- On unrated DVDs, playback will not be restricted even if the rating level is set.

- Once set, this rating level remains in memory until changed. To enable playback of discs of higher rating levels or to cancel the parental lock, the setting must be changed.
- Not all DVDs provide a Parental Lock feature. If you are unsure about a DVD, play it first to confirm. Do not leave DVDs accessible to young children for whom you deem them inappropriate.

- 1 Touch [INPUT].  
The numeric keypad screen is displayed.
- 2 Touch the numeric keypad to input a 4-digit password.  
The initial number is 1111.  
Input number are displayed as "\*".
- 3 Touch [ENT] to memorize the number.  
The PARENTAL screen appears.

**Set the rating level of PARENTAL**

- 4 Touch [◀] or [▶] of PARENTAL to turn on.
- 5 Touch [◀] or [▶] of PARENTAL LEVEL to select the rating level (1 to 8).  
Select "OFF" to cancel the parental lock or if you do not want to set a rating level. The smaller the number, the higher the rating level.
- 6 Touch [RETURN] to return to the previous screen.

**Changing the password**

- 4 Touch [INPUT] of PASSWORD CHANGE.  
The numeric keypad screen is displayed.
- 5 Touch the input screen to enter a new 4-digit password

- Keep a note of the number somewhere safe in case you should forget it.

- 6 Touch [ENT] to memorize the number.
- 7 Touch [RETURN] to return to the previous screen.

### **Changing the rating level temporarily**

Some discs may request that you change the rating level set in the default settings during playback. In this case, the message appears on the monitor screen "PARENTAL LEVEL CHANGE OK? [YES] [NO]."

If this screen appears, change the level as follows:

- **To change parental level and play, touch [YES].**
- **To play without changing the parental level, touch [NO].**  
(When [NO] is touched, playback will be at the parental level set in "Setting the Rating Level (Parental Lock).")

## Changing the Digital Output Setting

Use the following procedure to set the digital audio signal output from the IVA-D300.

**Setting item:** DIGITAL OUT MODE

**Setting contents:** AUTO / LPCM

- AUTO:** The digital output is switched automatically according to the type of audio signals being played.  
Be sure to select "AUTO" when you want to connect a digital audio processor and play Dolby Digital audio.  
"AUTO" is the factory setting.
- LPCM:** The audio signals recorded on the disc are converted to 48 kHz/16 bit (for DVDs) or 44.1 kHz (for video CDs and CDs) linear PCM audio signals for output.

## Audio output/Optical digital audio output

Disc	Audio recording format		Digital output setting	Optical digital audio output (when a digital audio processor is connected)	Analog audio output (Ai-NET, RCA output)
DVD	DTS		AUTO	DTS Elementary Stream	OK
			LPCM	LPCM Encode 2ch Down mix (48kHz/16bit)	OK
	Dolby Digital		AUTO	Dolby Digital	OK
			LPCM	LPCM (48kHz/16bit)	OK
	Linear PCM	48kHz/16bit	AUTO or LPCM	LPCM (48kHz/16bit)	OK
		48kHz/20bit	AUTO or LPCM	LPCM (48kHz/16bit)	OK
		48kHz/24bit	AUTO or LPCM	LPCM (48kHz/16bit)	OK
		96kHz/16bit	AUTO or LPCM	LPCM (48kHz/16bit)	OK
		96kHz/20bit	AUTO or LPCM	LPCM (48kHz/16bit)	OK
		96kHz/24bit	AUTO or LPCM	LPCM (48kHz/16bit)	OK
	MPEG2		AUTO or LPCM	LPCM (48kHz/16bit)	OK
Video CD	MPEG1		AUTO or LPCM	LPCM (44.1kHz)	OK
CD	Linear PCM		AUTO or LPCM	LPCM (44.1kHz)	OK
	DTS		AUTO	DTS Elementary Stream	OK
			LPCM	LPCM Encode 2ch Down mix (44.1kHz/16bit)	OK
MP3	MPEG Audio Layer3 Bit Rate: 32kbps~ 320kbps	32kHz/16bit	AUTO or LPCM	LPCM Encode 2ch (32kHz/16bit)	OK
		44.1kHz/16bit	AUTO or LPCM	LPCM Encode 2ch (44.1kHz/16bit)	OK
		48kHz/16bit	AUTO or LPCM	LPCM Encode 2ch (48kHz/16bit)	OK
WMA	Windows Media™ Audio Bit Rate: 32kbps~ 320kbps	32kHz/16bit	AUTO or LPCM	LPCM Encode 2ch (32kHz/16bit)	OK
		44.1kHz/16bit	AUTO or LPCM	LPCM Encode 2ch (44.1kHz/16bit)	OK
		48kHz/16bit	AUTO or LPCM	LPCM Encode 2ch (48kHz/16bit)	OK

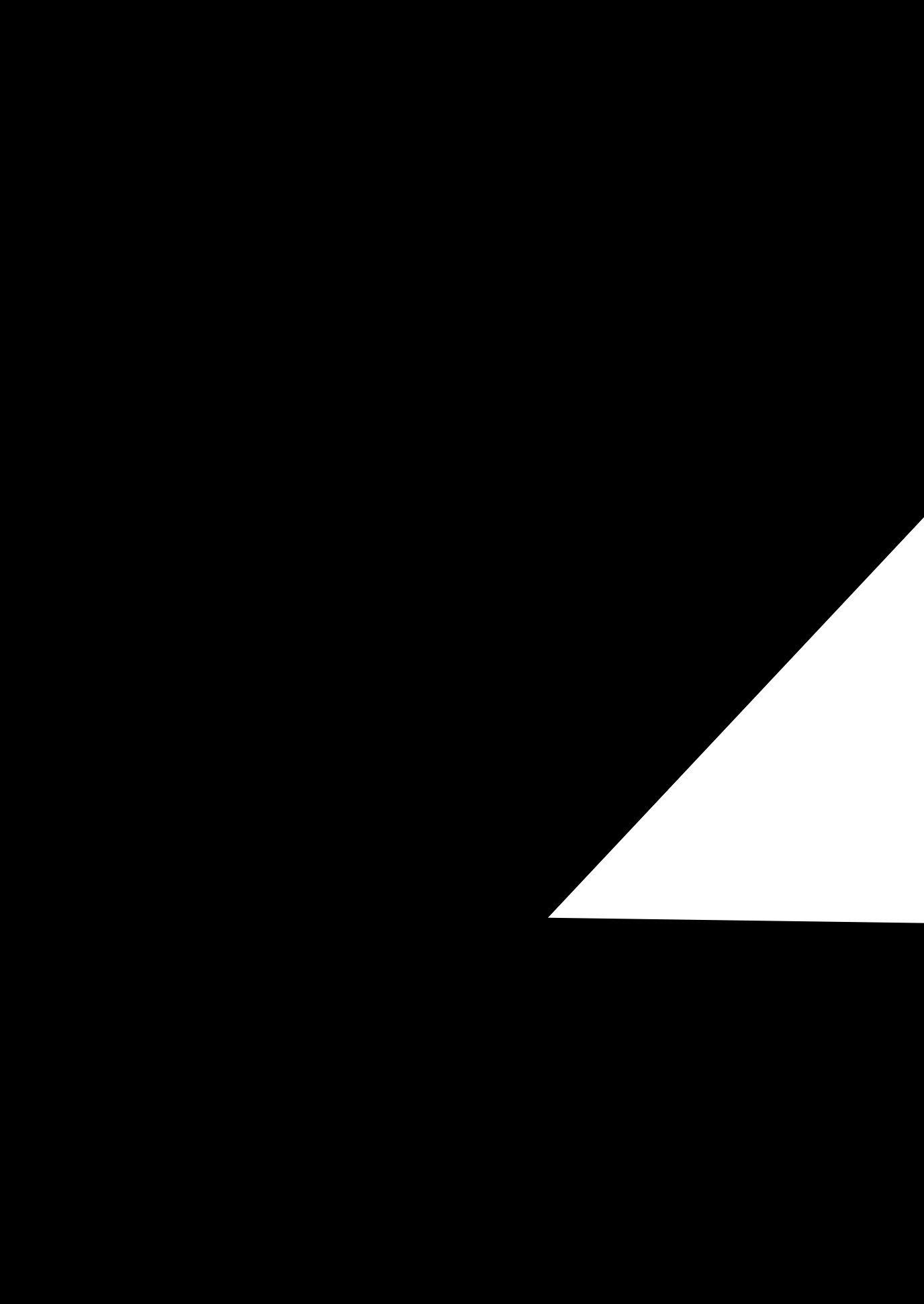



## Displaying the Time

The clock display is turned off or on respectively.

**Setting item: CLOCK**

**Setting content: OFF / ON**

## Setting the Time

**Setting item: CLOCK ADJUST**

**Further setting items: HOUR / MINUTE / TIME ADJUST**

**Setting content: 1-12 / 0-59 / RESET**

**HOUR:** Adjust the hour.

**MINUTE:** Adjust the minute.

**RESET:** If the clock shows less than 30 minutes past, the minute will be ": 00"; more than 30, the hour advances.

- *The clock-adjusting mode is cancelled when the power is turned off, when [RETURN] or [MAIN CONT.] is touched.*

## Setting Daylight Saving Time

**Setting item: DAYLIGHT SAVING TIME**

**Setting content: OFF / ON**

**ON:** Place the Summer Time mode ON. The time advances by one hour.

**OFF:** Return to the ordinary time.

## Demonstration Function

This unit is equipped with a demonstration function capable of showing basic operations of respective sources on the display.

**Setting item: DEMONSTRATION**

**Setting content: OFF / ON**

**ON:** Turns on the demonstration mode to show the basic operations.

**OFF:** Turns off the demonstration mode.

- *The demonstration operation is automatically repeated until the function is turned off.*

## Sound (Beep) Guide Function

**Setting item: BEEP**

**Setting content: OFF / ON**

**ON:** Activate the Sound Guide mode.

**OFF:** Deactivate the Sound Guide mode. The sound guide beep will not be produced when a button on the unit is pressed.

## Setting the Scroll

Scroll display is available if titles are entered in the disc. Scroll display of CD text, folder names, file names and tag information is also enabled.

**Setting item: AUTO SCROLL**

**Setting content: OFF / ON**

**ON:** Turns on the AUTO scroll mode. Scroll display is repeated as long as the mode is turned on.

**OFF:** Turns off the AUTO scroll mode.

Scroll display is done once as a track is changed.

## Setting the Sound Quality of the Tuner

The IVA-D300 incorporates the MAX TUNE SQ for the highest quality tuner audio. Moreover, you can choose between 3 settings to suit your own personal sound preferences and usage.

**Setting item: FM CONDITION**

**Setting content: NORMAL / HI-FI / STABLE**

**NORMAL:** Standard setting

**HI-FI:** Sound quality priority setting

**STABLE:** Noiseless priority setting

## Setting the Auxiliary Data Field Display

This display can be used only when the optional XM Satellite Radio Receiver (TUA-T021XM) is connected.

**Setting item: ADF**

**Setting content: OFF/ON**

**ON:** The Auxiliary Data Field is displayed in the XM mode.

**OFF:** The Auxiliary Data Field is not displayed.

## Switching the incoming calls of the telephone

This operation can be carried out only when a cellular phone and MobileHub (CXA-B200NK) is connected.

**Setting item: PHONE RECEIVE**

**Setting content: AUTO / MANUAL**

- *The incoming call can be switched to Automatic Calling or Manual Calling.*

## Playing MP3/WMA Data

When using discs containing both audio data and MP3/WMA data.

**Setting item: PLAY MODE**

**Setting content: CD / MP3**

**CD:** Plays only the audio data on discs containing both audio data and MP3/WMA data.

**MP3:** Plays only the MP3/WMA files on discs containing both audio data and MP3/WMA data.

- *Remove the disc from this unit before setting.*
- *When an MP3-compatible CD changer is used, this setting cannot be applied.*

# SYSTEM Setup

## System Setup Operation

### To display the System mode screen:

To watch a video source, your vehicle must be parked with the ignition key in the ACC or ON position. To do this, follow the procedure below.

1. Brake to bring your vehicle to a complete stop at a safe location. Engage the parking brake.
2. Keep pushing the foot brake and release the parking brake once then engage it again.
3. When the parking brake is engaged for the second time, release the foot brake.

- For automatic transmission vehicles, place the transmission lever in the Park position.

Now, the locking system for the System mode operation has been released. Engaging the parking brake can reactivate the System mode, as long as the car's ignition has not been turned off. It is not necessary to repeat the above procedure (1 through 3), of "To display the System mode screen."

Each time the ignition is turned OFF, perform the procedure of "To display the System mode screen."

The following steps 1 to 5 are common operations to each "Setting item" of SYSTEM Setup. Refer to each section for details.

### 1 Touch [SYS.] on the main source screen.

The SYSTEM selection screen is displayed.

### 2 Touch [SETUP].

The SETUP screen appears.

### 3 Touch [➤] of SYSTEM SETUP.

The SYSTEM setup screen appears.

### 4 Touch [◀] or [▶] of the desired item to change its setting.

#### Setting items:

IN INT. MUTE / IN INT. ICON / NAV. IN / NAV. MIX / EXPANSION BOX\*<sup>1</sup> / VISUALIZER\*<sup>2</sup> / AUX IN-1 / AUX IN-2\*<sup>2</sup> / AUX IN-3\*<sup>2</sup> / MONITOR OUT-1 / MONITOR OUT-2\*<sup>2</sup> / CAMERA IN / V.SEL KEY / A. PROC TYPE

\*<sup>1</sup> The setting is effective when the external expansion Box (VPE-S431) is connected.

\*<sup>2</sup> Displayed when the expansion Box is set to ON.

### 5 Touch [RETURN] to return to the previous screen.

Touch [MAIN CONT.] to return to the main source screen that was displayed before the setup operation was started.

- Immediately after inputting titles or changing the settings of System Mode (While the system is inputting the titles or data automatically) do not turn the ignition key (engine key) to OFF. Otherwise, a title may not be written, or the settings may not be changed.

## Setting the External Device Interrupt Mode

If an Alpine Ai-NET Auxiliary Input Adapter (KCA-801B) is connected to the IVA-D300, an Auxiliary Source will be allowed to interrupt the current audio source. For example, you can listen to a portable MP3 player through your car audio system even with a CD changer connected and playing. The CD changer will automatically mute when switched to the AUX Input. For further details on how to use the Alpine KCA-801B, see your authorized Alpine dealer.

#### Setting item: IN INT. MUTE

#### Setting content: OFF / ON

- OFF: The volume level can be adjusted in Interrupt mode.
- ON: Sound will not be output. The icon that is set in "Setting the Interrupt Icon Display" is displayed.

- The auxiliary device being connected must have an Interrupt wire with a negative trigger for this function to operate automatically. Otherwise, a separate switch needs to be added to switch it manually.

## Setting the Interrupt Icon Display

The unit can display the icon of an external device, such as a telephone, whenever a phone call comes in to tell you there is a phone call.

#### Setting item: IN INT. ICON

#### Setting content: INT / TEL

- INT: The INT icon appears on the display.
- TEL: When the external device (telephone) sends the interrupt signal, the telephone icon appears on the display.

- TEL icon on this setting is not related to TEL Link Operation (pages 55-57).

## Setting the Navigation Mode

When you connect an optional navigation equipment, set it to ON.

#### Setting item: NAV. IN

#### Setting contents: OFF / ON

- ON: Navigation source is displayed.
- OFF: Navigation source is not displayed. The settings related to the navigation can not be changed from this unit.

## Setting the Navigation Interruption

With an Alpine navigation system connected to the IVA-D300, the voice guidance of the navigation system will be mixed with the radio or CD play.

#### Setting item: NAV.MIX

#### Setting content: OFF / ON

- OFF: The navigation interruption mode is turned off.
- ON: The navigation interruption mode is on.

To adjust the navigation interruption volume level, the adjustment for NAV. LEVEL can be performed in "Adjusting the Audio" on page 22 after setting to ON.

- The audio volume during the navigation guide can be set by adjusting the audio volume while the navigation guide continues. When the navigation guide finishes, the previous audio volume and the previous screen are restored. For exception, if the navigation cuts in when the audio volume is lower than the setting level, the audio volume during the navigation guide is reset the current listening volume. (When the navigation guide cuts in, the audio volume does not increase.)
- This setting is effective when NAV.IN of SYSTEM list screen is ON.
- When PXA-H510 or PXA-H900 is connected, NAV.MIX value set in this unit does not affect PXA-H510 or PXA-H900.

## Connecting and Setting the External Expansion Box

This setting becomes necessary when the optional expansion box (VPE-S431) is connected.

**Setting item: EXPANSION BOX**

**Setting content: OFF / ON**

OFF: Select when the expansion box (VPE-S431) is not connected.

ON: Select when the expansion box (VPE-S431) is connected.

## Setting the VISUALIZER Mode Display

Select this display when displaying the source names of VISUALIZER on the VISUAL selection screen.

Note that this setting is enabled only when the optional expansion box (VPE-S431) is connected.

**Setting item: VISUALIZER**

**Setting contents: OFF / ON**

OFF: "VISUALIZER" and source names are not displayed on the VISUAL selection screen.

ON: "VISUALIZER" and source names are displayed on the VISUAL selection screen.

## Setting the AUX Mode

**Setting item: AUX IN-1, 2, 3**

**Setting content: OFF / ON**

OFF: AUX source is not displayed.

ON: AUX source is displayed.

- OFF is not displayed when the optional DVD player or DVD changer is connected.
- When OFF is selected, the settings related to AUX cannot be changed from this unit.
- When either DVD player or DVD changer is connected to AUX IN 1, EXT. DVD is displayed on the screen. When both of them are connected, EXT. DVD is displayed for AUX IN 1 and DVD CHG is displayed for AUX IN 2.
- AUX IN 2,3 is displayed when the external expansion box (VPE-S431) is connected.

## Naming External Devices

When more than one external device is connected, you can name each (up to 3) as you like. After setting to ON in "Setting the AUX mode," touch any one of the [>>] buttons of AUX IN 1 through 3, then this setting may be carried out.

**Setting items: NAME**

**Setting contents: AUX / VCR / GAME-1,2 / TV / NAV.**

- The selected source name is displayed instead of AUX source name. When a source is selected, the Function Guide of AUX mode appears.
- Only AUX IN-3 MODE can be named "NAV." When AUX mode is selected, "NAV." is displayed as the source name. This setting is recommended if you view the navigation screen on the rear monitor. However, it is available only when the Alpine navigation system (except RGB navigation) is connected.
- Only when an Alpine TV tuner is connected, can you operate the displayed function guide from this unit.

## Adjusting the External Input Audio Level

After setting to ON in "Setting the AUX mode," touch any one of the [>>>] buttons of AUX IN 1 through 3, then this setting may be carried out.

**Setting item: LEVEL**

**Setting content: LOW / HIGH**

LOW: Decreases the external input audio level

HIGH: Increases the external input audio level

## Setting of the External Monitor Output

Set it to ON when you use the rear entertainment function (page 23).

**Setting items: MONITOR OUT-1, 2**

**Setting contents: OFF / ON**

ON: By setting the connected external monitor to ON, the remote control will be usable.

OFF: When either MONITOR OUT 1 or 2 is set to OFF, only one monitor can be set by the rear enter function. When both MONITOR OUT 1 and 2 are set to OFF, REAR SELECT, which is displayed on the SYSTEM selection screen, cannot be used.

- "MONITOR OUT-2" is displayed when "ON" is set in "Connecting and Setting the External Expansion Box" on page 33.

## Setting of the Rear Camera

When the rear camera is connected, rear pictures are output on the screen.

**Setting item: CAMERA IN**

**Setting contents: OFF / ON**

ON: Even if the shift lever is not set to reverse (R), the rear pictures are output by pressing V.SEL and selecting the CAMERA source.

OFF: The rear pictures are not output.

- By shifting to reverse (R), the rear pictures are output. This function is effective when the reverse wire is properly connected.

## Setting Visual Mode

This setting changes the function of the V.SEL button on the unit.

**Setting item: V.SEL KEY**

**Setting content: V.SEL / NAV.**

NAV.: Pressing V.SEL directly switches to the navigation screen. (Only when an Alpine optional RGB Navigation is connected.)

V.SEL: Press V.SEL to recall the VISUAL Select screen.

## **Optical Digital Input Selection for an External Audio Processor**

Make sure "OPTICAL OUT" is ON in "Setting the Digital Output" (page 30) before switching this setting.

**Setting item: A.PROC TYPE**

**Setting contents: PXA-H510 / OTHER**

**OTHER:**

When connecting any audio processor via an optical digital cable except the PXA-H510.

Connect the optical digital input connector with the connector for the Head unit.

**PXA-H510:**

When connecting PXA-H510.

Connect the optical digital input connector with the connector for the DVD.

- *After input selection is completed, turn ignition OFF and back ON again. Your setting of the optical digital input switch is completed.*

## **DISPLAY Setup**

### **Display Setup Operation**

**To display the Display mode screen:**

To watch a video source, your vehicle must be parked with the ignition key in the ACC or ON position. To do this, follow the procedure below.

1. Bring your vehicle to a complete stop at a safe location. Engage the parking brake.
2. Keep pushing the foot brake and release the parking brake once then engage it again.
3. When the parking brake is engaged for the second time, release the foot brake.

- *For automatic transmission vehicles, place the transmission lever in the Park position.*

Now, the locking system for the Display mode operation has been released. Engaging the parking brake can reactivate the Display mode, as long as the car's ignition has not been turned off. It is not necessary to repeat the above procedure (1 through 3), of "To display the Display mode screen." Each time the ignition is turned OFF, perform the procedure of "To display the Display mode screen."

The fa comone operatios1 to eah" ]T 1. TD . 1 Tc Tw[" Setting ite" of DISPLA 5. Y Setuf. Refver to eah seitionf 4. a " ]T 1.

T h e S E T U P e

## Setting Automatic Background Textures

Turn on the Automatic Background Texture Scroll to automatically change background texture. The background texture will change each time the ignition key is turned off and turned back on again (5 textures).

**Setting item: AUTO BACKGROUND**

**Setting content: OFF / ON**

- ON:** Turn on the Auto Background Texture Scroll mode. The background textures will scroll when the ignition key is turned off once and turned back on again as follows:  
MODE1 → MODE2 → MODE3 → MODE4 →  
MODE5 → MODE1
- OFF:** Turn off the Auto Background Texture Scroll mode.

## Setting the Font Type

You can choose a character (text and tag information, etc.) font type for the main display.

**Setting item: FONTTYPE**

**Setting content: FONT 1 / FONT 2**

- FONT1: Selects bold characters.  
FONT2: Selects round characters.

## Switching the Font Back Display Color

You can choose from 5 different display colors for the font back (source title, shortcut display, etc.).

**Setting item: FONT COLOR**

**Setting contents: MODE 1 to MODE 5**

## Turning the Touch Panel Vibration ON or OFF

You can turn the touch panel's vibration ON or OFF during operation.

**Setting item: TOUCH PANEL**

**Setting content: NORMAL / FORCE**



- NORMAL: Turns off vibration during operation.  
FORCE: Turns on vibration during operation.

## Adjusting the Touch Panel

Adjustment becomes necessary when the display position on the LCD and the touch position on the touch panel do not match.

**Setting item: SCREEN ALIGNMENT**

**Setting content:  / RESET**

- 1 Touch [**>>**] of SCREEN ALIGNMENT. The adjustment screen appears.
  - 2 Accurately touch the  mark provided in the lower left corner of the screen. The screen changes to the adjustment screen.
  - 3 Accurately touch the  mark provided in the upper right corner of the screen. This completes adjustment, and returns to the DISPLAY setup mode screen.
- If you have touched a location other than the  mark, touch [**RESET**] to restore the adjustment screen to the initial setting.
  - If you touch [**RETURN**] on the adjustment screen, no adjustment is done and the DISPLAY setup screen is restored.

# i-Personalize™

## Media Xpander Function

### Setting the MX mode

#### To display the i-Personalize mode screen:

To watch a video source, your vehicle must be parked with the ignition key in the ACC or ON position. To do this, follow the procedure below.

1. Bring your vehicle to a complete stop at a safe location. Engage the parking brake.
2. Keep pushing the foot brake and release the parking brake once then engage it again.
3. When the parking brake is engaged for the second time, release the foot brake.

- For automatic transmission vehicles, place the transmission lever in the Park position.

Now, the locking system for the i-Personalize mode operation has been released. Engaging the parking brake can reactivate the i-Personalize mode, as long as the car's ignition has not been turned off. It is not necessary to repeat the above procedure (1 through 3), of "To display the i-Personalize mode screen."  
Each time the ignition is turned OFF, perform the procedure of "To display the i-Personalize mode screen."

MX (Media Xpander) makes vocals or instruments sound distinct regardless of the music source. The radio, CD, and MP3, will be able to reproduce the music clearly even in cars with a lot of road noise.

- 1 **Touch [SYS.] on the source main screen.**  
The SYSTEM selection screen is displayed.
- 2 **Touch [i-Personalize].**  
The screen changes to the i-Personalize.
- 3 **Touch [◀] or [▶] of MEDIA XPANDER to turn MX ON or OFF.**  
OFF: MX mode is canceled for all music sources.  
ON: The selected MX mode is turned on.
- 4 **After setting to ON, touch [>>].**  
The screen changes to the Media Xpander setting screen.

**Continued**

## 5 Touch [◀] or [▶] of the desired MX mode.

The level of the audio source can be adjusted.

### MX CD (OFF, CD1 to 3)

The large quantity of uncompressed CD data is processed to reproduce the sound with more clarity.

### MX COMPRESS MEDIA (OFF, CMPM1 to 3)/MX XM (OFF, XM1 to 3)

This corrects information that was omitted at the time of compression. This reproduces a well-balanced sound close to the original.

### MX FM (OFF, FM1 to 2)

The medium to high frequencies become more clear, and produces well balanced sound in all the bands.

### MX DVD (OFF, MOVIE 1 to 2)

The dialog portion of the video is reproduced more clearly.

### (DVD MUSIC)

This disk contains a large quantity of data such as a music clip. MX uses this data to reproduce the sound accurately.

### MX AUX 1 to 3 (OFF, MP3, MOVIE, MUSIC)

Choose the MX mode (MP3, MUSIC, or MOVIE) that corresponds to the media connected.

## 6 Touch [RETURN] to return to the previous screen.

- When OFF is selected, MX effect of each MX mode will be off.
- Each music source, such as radio, CD and MP3 can have its own MX setting.
- AUX is displayed when ON is selected in "Setting the AUX Mode" (page 33).
- MX mode does not function for AM radio when MX is ON.
- MX COMPRESS MEDIA is applied for MP3/WMA, MMD.
- If the unit is connected to an audio processor with the MX function, such as PXA-H700, etc., the MX processing can be applied to the audio processor. In this case the audio processor needs to be adjusted. For details, refer to the Owner's Manual of the audio processor.
- This function is inoperable when Defeat is set to ON.

## Bass Engine Function

### Setting the Bass Engine

The following steps 1 to 6 are common operations to each "Setting item" of bass engine Setup. Refer to each section for details.

#### 1 Touch [SYS.] on the source main screen.

The SYSTEM selection screen is displayed.

#### 2 Touch [i-Personalize].

The i-Personalize screen appears.

#### 3 Touch [≫] of BASS ENGINE.

The screen changes to the Bass Engine setting screen.

#### 4 Touch [≫] of the desired Bass Engine setting item.

##### Setting items

BASS MAX EQ / P-EQ / BASS FOCUS / T.CORR (TIME CORRECTION) / X-OVER / SUBWOOFER

#### 5 Touch [◀] or [▶] of the selected setting item, and change the setting.

- When setting is complete, storing in memory is recommended.

#### 6 Touch [RETURN].

The screen returns to the previous one.

### Selecting Bass EQ mode (Maker's setting)

10 typical equalizer settings are preset at the factory for a variety of musical source material.

##### Setting item: BASS MAX EQ

Setting contents: FLAT / ROCK / POPS / JAZZ / ELECTRIC / HIPHOP / EASY / COUNTRY / CLASSIC / NEWS / CUSTOM \*

\* Contents that are adjusted in parametric EQ.

### Adjusting and Storing/Recalling the Parametric EQ

The frequency bands of the graphic equalizer are fixed. This makes it very difficult to correct for undesired peaks and dips at specific frequencies. The parametric equalizer's center frequency can be tuned to these specific frequencies. Then, the bandwidth (Q) and level are fine-tuned, independently, to make the necessary corrections. The parametric equalizer function is an advanced tool for serious audiophiles.

##### Setting item: P-EQ

Further setting items: HIGH / MID-HIGH / MID-LOW / LOW

Setting contents: FREQ / LEVEL / Q

- 1 Touch [≫] of P-EQ.

The screen changes to the P-EQ setup screen.

- 2 Touch a desired item for adjustment.

FREQ: Adjusts the center frequency.

LEVEL: Adjusts the level.

Q: Adjusts the bandwidth (Q).

- After the necessary selection is done in Step 2 above, adjust a desired band by touching [◀] or [▶] corresponding to that band.

**Center Frequency**

HIGH: 10kHz, 12.5kHz, 15kHz  
 MID-HIGH: 500Hz, 700Hz, 1kHz, 2kHz, 4kHz, 6kHz  
 MID-LOW: 100Hz, 150Hz, 200Hz  
 LOW: 40Hz, 60Hz, 90Hz

**Level: ±12**

**Bandwidth (Q):** HIGH: 1.0 (currently specified bandwidth cannot be adjusted in HIGH).  
 MID-HIGH: 1.0, 2.0, 3.0  
 MID-LOW: 1.0, 1.5, 2.0  
 LOW: 1.0, 2.0, 3.0

- If you set the parametric EQ, BASS EQ setting content is set to "CUSTOM."

- When adjusting another band, repeat Steps 2 and 3 above.
- Touch [RETURN] to return to the previous screen.

**Storing Adjusted Contents**

The following operation is performed after Step 5 above.

- Touch [MEMORY].
- Within 5 seconds, touch any one of preset buttons [P.SET 1] through [P.SET 6] on the BASS ENGINE screen.  
 The adjusted contents are stored on the P.SET number you touch.

- The stored contents on the P.SET number remain undeleted despite a following reset operation or disconnection of the battery power cord.
- Adjusted/set contents of each setting item in Bass Engine can be stored in the preset buttons (1 through 6).

**Recalling the Adjusted and Stored Contents**

Following operation is performed after Step 5 above.

- Touch any one of [P.SET 1] to [P.SET 6] on the BASS ENGINE screen.  
 Recall the adjusted and stored contents.

- The frequencies of adjacent bands cannot be adjusted within 4 steps.
- This function is inoperable when Defeat is set to ON.

**About the Time Correction**

The distance between the listener and the speakers in a car vary widely due to the special conditions of the mobile environment. This difference in the distances from the speakers to the listener creates a shift in the sounds image and frequency characteristics. This is caused by the time delay between the sound reaching the listener's right versus left ear.

To correct this, the IVA-D300 is able to delay the audio signal to the speakers closest to the listener. This effectively creates a perception of increased distance for those speakers. The listener can be placed at an equal distance between the left and right speakers for optimum staging.

The adjustment will be made for each speaker in a step of 0.1 ms.

**Example 1. Listening Position: Front Left Seat**

Adjust the time correction level of the front left speaker to a high value and the rear right to zero or a low value.

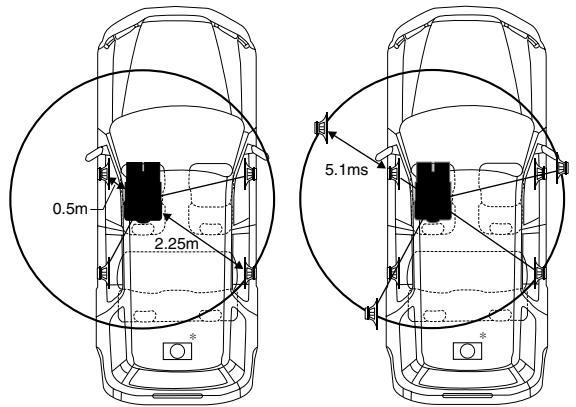

**Tips**

**\* Subwoofer speaker**

You cannot change the time correction value for the subwoofer, but you can set the subwoofer's apparent position to the front by adjusting the time correction value of the front and rear speakers.

For details, refer to the "Tips" on page 39.

Here we calculate the time correction value for the front left speaker in the diagram above.

**Conditions:**

Farthest Speaker – listening position: 2.25 m (88-9/16")

Front left speaker – listening position: 0.5 m (19-11/16")

Calculation:  $L = 2.25\text{ m} - 0.5\text{ m} = 1.75\text{ m}$  (68-7/8")

Time correction =  $1.75 \div 343^{**} \times 1000 = 5.1$  (ms)

\*\* Speed of sound: 343 m/s (765 mph) at 20°C

The sound is not balanced because the distance between the listening position and the various speakers is different.

The difference in distance between the front left speaker and the rear right speaker is 1.75 m (68-7/8").

Time correction eliminates the differences in the time required for the sound to reach the listening position.

The time of the front left speaker is corrected by 5.1 ms so that its sound reaches the listening position at the same time as the sound of other speakers.

In other words, giving the front left speaker a time correction value of 5.1 ms makes it seem as if the distance to the front left speaker is the same as the distance to the farthest speaker.

**Continued**

**Example 2. Listening Position: All Seats**

Adjust the time correction level of each speaker to almost the same level.

- 1 Sit in the listening position (driver's seat, etc.) and measure the distance (in meters) between your head and the various speakers.
- 2 Calculate the difference between the distance to the farthest speaker and the other speakers.

$L =$  (distance to far



## Example of Bass Focus Setting

- 1 After entering corrections for the front (left and right) speakers in STEP 15, the time difference is 1.5 ms for both front-left and front-right speakers.

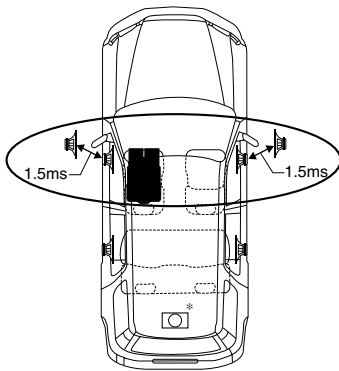

- 2 After entering corrections for the left (front and rear) speakers in STEP 15, the time difference becomes 3.0 ms\*\* for the front left speaker and 1.5 ms for the left rear speaker.

\*\* Because the time difference was already set to 1.5 ms for the front left speaker in STEP 1, the additional correction in STEP 15 makes the time difference of the front left speaker 3.0 ms.

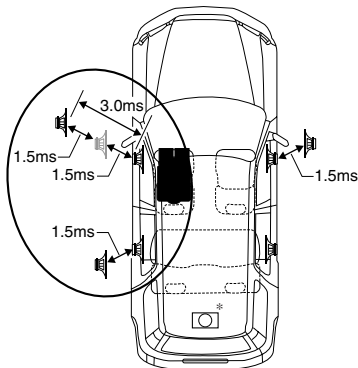

### Tips

#### \* Subwoofer speaker

Delay (turn the rotary encoder) the audio signal to the front (left and right) speakers to make the apparent position of the subwoofer to be at the front. In doing this, the apparent position between the front (left and right) speakers and subwoofer will appear equal to the driver. After performing above, you can change the positions of left and right speakers by delaying the time.

## Adjustment and Storing/Recalling of Time Correction

Before performing the following procedures, refer to "About the Time Correction" (page 37).

### Setting item: T.CORR (TIME CORRECTION)

Setting contents: 0.0-9.9

- 1 Touch [ >>> ] of T.CORR.  
The screen changes to the T.CORR. setup screen.
- 2 Touch [ ◀ ] or [ ▶ ] of the desired speaker to adjust the time correction value (0.0 to 9.9).
- 3 Repeat Step 2 above to set another speaker.
- 4 Touch [ RETURN ] to return to the previous screen.

- The setting contents which have been set in "Time Correction" are applied for the Bass Focus mode.

## Storing the Adjusted Contents

The storing/recalling of time correction operation is performed after Step 4 above.

- 5 Touch [ MEMORY ].
- 6 Within 5 seconds, touch any one of preset buttons [ P.SET 1 ] through [ P.SET 6 ] on the BASS ENGINE screen.  
The adjusted contents will be stored on the preset number you touch.

- The stored contents on the P.SET number remain undeleted despite a reset operation or disconnection of the battery power cord.
- Adjusted/set contents of each setting item in Bass Engine can be stored in the preset buttons (1 through 6).

## Recalling the Stored Time Correction Setting

The storing/recalling of time correction operation is performed after Step 4 above.

- 5 Touch any one of [ P.SET 1 ] to [ P.SET 6 ] on the BASS ENGINE screen.  
The stored adjusting contents will be recalled.

## Adjustment and Storing/Recalling of the Built-in Crossover

The High and Low Pass Filters on this unit can be adjusted to suit your personal taste.

### Setting item: X-OVER

Setting contents: LPF / HPF

- 1 Touch [ >>> ] of X-OVER.  
The screen changes to the X-OVER setup screen.
- 2 Adjust LPF/HPF by touching [ ◀ ] or [ ▶ ] of LPF or HPF.

LPF: Outputs all frequencies lower than that selected according to your preference.  
(Only available when using the subwoofer output from this unit.)

HPF: Outputs all frequencies higher than that selected according to your preference.

- 3 Touch [ RETURN ] to return to the previous screen.

- When the subwoofer output of this unit is turned OFF, LPF and phase are deactivated.
- Except when the HPF and LPF is turned OFF, the subwoofer is in monaural mode.

Continued

## Storing the Adjusted Contents

Following operation is performed after Step 3 above.

- 4 Touch [MEMORY].
  - 5 Within 5 seconds, touch any one of preset buttons [P.SET 1] through [P.SET 6] on the BASS ENGINE screen. The adjusted contents will be stored on the preset number you touch.
- The stored contents on the P.SET number remain undeleted despite a reset operation or disconnection of the battery power cord.
  - Adjusted/set contents of each setting item in Bass Engine can be stored in the preset buttons (1 through 6).

## Recalling the Stored Adjusting Contents

Following operation is performed after Step 3 above.

- 4 Touch any one of [P.SET 1] to [P.SET 6] on the BASS ENGINE screen. The stored adjusting contents will be recalled.

## Subwoofer On and Off

**Setting item:** SUBWOOFER

**Setting contents:** OFF / 0° / 180°

- OFF: Subwoofer output is off.  
0°: Subwoofer output is on, and the phase is 0°.  
180°: Subwoofer output is on, and the phase is 180°.

- Adjusted/set contents of each setting item in Bass Engine can be stored in the preset buttons (1 through 6).

## VISUAL EQ™

### Visual EQ Setting Operation

The following steps 1 to 6 are common operations to each "Setting item" of VISUAL EQ setting. Refer to each section for details

- 1 Touch [SYS.] on the main source screen.**  
The SYSTEM selection screen is displayed.
- 2 Touch [i-Personalize].**  
The i-Personalize setup screen appears.
- 3 Touch [≫] of VISUAL EQ.**  
VISUAL EQ screen appears.
- 4 Select a desired setting item by touching [▲] or [▼].**  
**Setting items:**  
VISUAL EQ\* ↔ BRIGHT ↔ COLOR\* ↔ TINT\* ↔ CONTRAST  
↔ SHARP\* ↔ USER MEMORY\*  
*\* The setting is available in the visual source mode. (except navigation screen)*
- 5 Change the setting on the selected item by touching its [◀] or [▶].**
- 6 Touch [RETURN] to return to the previous screen.**  
Touch [MAIN CONT.] to return to the main source screen that was displayed before the setup operation was started.

### Selecting the VISUAL EQ Mode (Maker's setting)

You can select a mode suitable for the subject image.

**Setting item:** VISUAL EQ

**Setting contents:** OFF (FLAT) / NIGHT M. / SOFT / SHARP / CONTRAST / P-1 / P-2

- OFF (FLAT): Initial Setting  
NIGHT M.: Suitable for movies in which dark scenes frequently appear.  
SOFT: Suitable for CGs and animated films.  
SHARP: Suitable for old movies where images are not clearly shown.  
CONTRAST: Suitable for recent movies.  
P-1: Recalls the VISUAL EQ mode being stored on preset No.P-1 from "Storing VISUAL EQ" (page 41).  
P-2: Recalls the VISUAL EQ mode being saved on preset No.P-2 from "Storing VISUAL EQ" (page 41).

- To return to the initial setting after selecting any one of the setting contents (NIGHT M. to CONTRAST) and adjusting a desired brightness, picture tint, etc., set this function to OFF.
- If your desired brightness, picture tint, etc., are adjusted after selecting any one of the setting contents (NIGHT M. to CONTRAST), "CUSTOM" is displayed.

### Adjusting Brightness

**Setting item:** BRIGHT

**Setting content:** -15 ~ +15

You can adjust the brightness between MIN (-15) and MAX (+15). When it reaches the minimum or maximum point, the display shows "MIN" or "MAX" respectively.

## Adjusting Color of Picture

**Setting item: COLOR**

**Setting content: -15 ~ +15**

You can adjust the color between MIN (-15) and MAX (+15). When it reaches the minimum or maximum point, the display shows "MIN" or "MAX" respectively.

- Color adjustment can be made only in the navigation, DVD, AUX1 and AUX2 modes.
- Color adjustment cannot be made if a Navigation system with the RGB feature is connected.

## Adjusting Tint of Picture

**Setting item: TINT**

**Setting content: G15 ~ R15**

Adjust the color from G15 to R15. "G MAX" or "R MAX" is displayed at the maximum of each color.

- Tint adjustment can be made only in the navigation, DVD, AUX1 and AUX2 modes.
- Tint adjustment cannot be made if a Navigation system with the RGB feature is connected.

## Adjusting Image Contrast

**Setting item: CONTRAST**

**Setting content: -15 to +15**

Adjustment of contrast is done in the range of -15 to +15. "HIGH" and "LOW" appear as the maximum and minimum values specified.

## Adjusting Picture Quality

**Setting item: SHARP**

**Setting content: -15 to +15**

Adjustment of picture quality is done in the range of -15 to +15. "HARD" and "SOFT" appear as the maximum and minimum values specified.

- Picture quality adjustment can be made only in the navigation, DVD, AUX1 and AUX2 modes.
- Picture quality adjustment cannot be made if a Navigation system with the RGB feature is connected.

## Storing VISUAL EQ

You can store the settings made for "Adjusting Image Brightness, Tint, Depth, Picture Quality and Contrast."

**Setting item: USER MEMORY**

**Setting content: P-1/P-2**

- 1 After completing "Adjusting Brightness, Tint, Depth, Picture Quality, and Contrast" (this page), touch [◀] or [▶] of USER MEMORY and then select preset No. [P-1] or [P-2] to which the settings are to be stored.
  - 2 After selecting a preset No., touch [WRITE].  
The adjusted VISUAL EQ mode is stored by the above operations.
- You can recall the VISUAL EQ mode stored here from P-1 or P-2 of "Selecting the VISUAL EQ Mode" (page 40).

## Data Download

### About SOUND SETUP Download

You can download data (from Alpine's website) to a CD-R/CD-RW or HDD, and download and store the data to the IVA-D300.

To start SOUND SETUP download, access the URL below and follow the on-screen instructions.

<http://www.alpine.com> or <http://www.alpine-europe.com>  
or <http://www.alpine.com.au>

Downloadable data

Parametric equalizer	Data is memorized in Preset 6 of the Parametric EQ Mode.
Time correction	Data is memorized in Preset 6 of the Time Correction Mode.
Crossover	Data is memorized in Preset 6 of the crossover mode.

The file name of download data shall be "A\_U\*\*\*\*\*.MP3."

A\_U\*\*\*\*\*.MP3

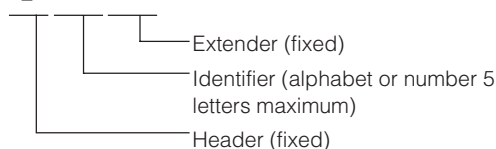

You can create a file name via the website. Do not change a file name once it has been created. Malfunction may result.

- For details about procedures of download, see ALPINE's Web site.
- If an external audio processor is connected, data that is downloaded cannot be used.

## Setting AMP Link (Optional)

### **Adjusting and Storing/Recalling the External Amplifier (Option)**

When an external amplifier (MRD-M301 or MRD-M501) is connected, you can set it from this unit. Up to eight amplifiers can be set.

## Recalling the Stored Contents of Amplifier Adjustment

- 1 Select P-1 or P-2 by touching [◀] or [▶] of MEMORY READ from the adjustment mode list.
- 2 Touch [READ].  
Stored adjustment data will be recalled.

## Titling the Amplifier

- 1 From the **AMPLIFIER LINK** list screen, touch [≫] of an amplifier to which a title is to be given.  
The adjustment mode list screen appears.
- 2 Touch [≫] of **NAME**.  
The title input screen appears.
- 3 Touch the desired character symbols.  
You can use up to 8 characters.
- 4 After the input, touch [ENT] to confirm your entry.  
As the entry is confirmed, the screen immediately before the current one will be restored, and the title that has been entered from the **AMPLIFIER LINK** list screen is shown.

## Displaying Status of External Amplifier

You can display the status of the connected external amplifier (MRD-M301 or MRD-M501) for AMP Link.

- 1 Touch [V.SEL] on the main source screen.  
The VISUAL selection screen appears.
- 2 Touch [AMP STATUS].  
The AMP status screen appears.

Display Example for AMP status screen

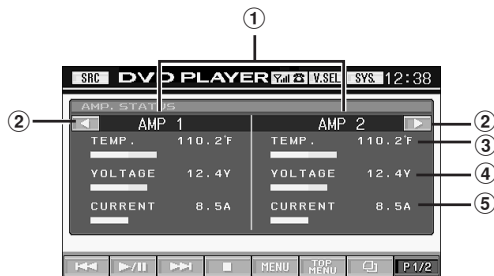

- ① Amplifier Name
- ② Turns pages
- ③ Temperature (°F)
- ④ Voltage (V)
- ⑤ Electric Currency

- 3 To cancel the **AMP** status screen, touch [V.SEL].  
The VISUAL selection screen is displayed.
- 4 Touch [NORMAL].  
The screen returns to the normal screen.

## External Audio Processor (Optional)

When an external audio processor is connected to this unit, you can operate it from this unit. Some audio processors may not be operated. When PXA-H510 or PXA-H900 is connected, some of the operations may not be performed from this unit. In this case, operate them in the connected product. Explanations below is the case when PXA-H700 or PXA-H701 is connected for example.

Refer also to the operating instructions of the connected audio processor.

- The adjustments or settings performed on the connected audio processor cannot be operated properly from this unit.

### To display the Audio processor mode screen:

To watch a video source, your vehicle must be parked with the ignition key in the ACC or ON position. To do this, follow the procedure below.

1. Bring your vehicle to a complete stop at a safe location. Engage the parking brake.
2. Keep pushing the foot brake and release the parking brake once then engage it again.
3. When the parking brake is engaged for the second time, release the foot brake.

- For automatic transmission vehicles, place the transmission lever in the Park position.

Now, the locking system for the Audio processor mode operation has been released. Engaging the parking brake can reactivate the Audio processor mode, as long as the car's ignition has not been turned off. It is not necessary to repeat the above procedure (1 through 3), of "To display the Audio processor mode screen."  
Each time the ignition is turned OFF, perform the procedure of "To display the Audio processor mode screen."

Continued

## Adjustment Procedure for Dolby Surround

Make the adjustments described below in order to reproduce Dolby Digital and DTS sound with greater accuracy.

### Adjustment procedure

- 1 Speaker Setup (page 48)**  
(Turning the speakers to be used on and off and setting their response)

↓

- 2 Adjusting the speaker levels (page 49)**  
(Adjusting the signal output level to the various speakers)

↓

- 3 Mixing bass sound to the rear channel (page 48)**  
(Achieving smooth sound in the rear seat by mixing the front audio signals with the rear speaker signals)

↓

- 4 Adjusting the acoustic image (page 48)**  
(Adjusting the acoustic image to achieve a sound as if the center speaker were directly in front of the listener)

↓

- 5 Achieving powerful high volume sound (page 49)**  
(Achieving energetic sound with even greater power, like the sound in a movie theater)

↓

- 6 Adjusting the DVD Level (page 49)**  
(Adjust the volume (signal level) in the Dolby Digital, Pro Logic II, DTS and PCM modes.)

↓

- 7 Storing Settings in the Memory (page 49)**  
(Storing all the settings and adjustments made on the IVA-D300 (not only the above settings/adjusts) in the memory)

**In case of combining the Automatic adjustments etc.**

We recommend to make the Automatic adjustments before the Dolby Surround adjustments.

## Setting the Speakers

- 1 Check that Defeat mode is off (page 22).**
- 2 Touch [SYS.] on the main source screen.**  
The SYSTEM selection screen is displayed.
- 3 Touch [i-Personalize].**  
The i-Personalize screen appears.
- 4 Touch [➤] of A.PROCESSOR.**  
The A.PROC list screen appears.
- 5 Touch [➤] of SPEAKER SELECT.**  
The SPEAKER SELECT screen appears.
- 6 Set the connected speaker by touching the respective [◀] or [▶] button.**  
  
FRONT1: OFF/FULL (Full Range)/TW (Tweeter)  
FRONT2: OFF/ON  
REAR: OFF/ON  
CENTER: OFF/ON  
SUBWOOFER: OFF/MONO/STEREO
- 7 Touch [RETURN] to return to the previous screen.**

- Set the speaker which is not connected to OFF.
- Settings above can be carried out even when the speaker is set to OFF in "Speaker Setup" (page 48).
- To use the subwoofer in MONO with PXA-H700 or PXA-H701 connected, connect the subwoofer to the subwoofer output terminal of PXA-H700 or PXA-H701.

## Set MX Mode of the External Audio Processor

Before performing the operations below, set MX (Media Xpander) mode of the PXA-H700 to "AUTO" when the PXA-H700 is connected.

- 1 Check that Defeat mode is off.**
- 2 Touch [SYS.] on the main source screen.**  
The SYSTEM selection screen appears.
- 3 Touch [i-Personalize].**  
The i-Personalize screen will appear.
- 4 Select ON or OFF of MX by touching [◀] or [▶] of MEDIA XPANDER.**  
  
OFF: Turns off the MX effect of every music source.  
ON: Turns on the specified MX mode.
- 5 Touch [➤] after setting to ON.**  
The Media Xpander setup screen appears.

## 6 Touch [◀] or [▶] of the desired MX mode.

- *Music source (such as radio broadcasts and CDs, excluding AM radio) level can be set.*

### **MX CD (OFF, CD 1 to 3)**

CD mode processes a large quantity of data. This data is used to reproduce the sound cleanly by making use of the data quantity.

### **MX COMPRESS MEDIA (OFF, CMPM 1 to 3) / MX XM (OFF, XM 1 to 3)**

This corrects information that was omitted at the time of compression. This reproduces a well-balanced sound close to the original.

### **MX FM (OFF, FM 1 to 3)**

The medium to high frequencies become more clear, and produces well balanced sound in all the bands.

### **MX DVD (OFF, MOVIE 1 to 2)**

The dialog portion of the video is reproduced more clearly. **(DVD MUSIC)**

This disk contains a large quantity of data such as music clip. MX uses this data to reproduce the sound accurately.

### **MX AUX 1 to 3 (OFF, MP3, MOVIE, MUSIC)**

Choose the MX mode (MP3, MUSIC, or MOVIE) that corresponds to the media connected.

## 7 Touch [RETURN] to return to the previous screen.

- *The contents of MX set here is reflected to PXA-H700 or PXA-H701.*
- *When OFF is selected, MX effect of each MX mode will be OFF.*
- *Each music source, such as radio, CD, and MP3 can have its own MX setting.*
- *MX mode does not function when MX is ON for AM radio.*
- *MX COMPRESS MEDIA is applied for MP3/WMA, MMD.*

## X-OVER Adjustment

### 1 Check that Defeat mode is off.

### 2 Touch [SYS.] on the main source screen.

The SYSTEM selection screen appears.

### 3 Touch [i-Personalize].

The i-Personalize screen will appear.

### 4 Touch [≫] of A.PROCESSOR.

The A.PROC list screen appears.

### 5 Touch [◀] or [▶] of X-OVER to select L/R or L+R.

L/R: Different adjustment values can be set for the left and right channels.

L+R: Sets the same adjustment values for the left and right channels.

### 6 Touch [≫] of X-OVER.

The X-OVER adjustment screen appears.

## 7 Touch a desired adjustment mode.

- FREQ: Adjust the H.P.F. or L.P.F. cutoff frequency. The adjustable bands differ according to the channel (speaker).
- SLOPE: Adjust the H.P.F. or L.P.F. slope.
- LEVEL: Adjust the H.P.F. or L.P.F. level.

## 8 Touch [◀] or [▶] of the speaker to adjust its channel.

## 9 When adjusting another channel, repeat steps 7 and 8 above.

## 10 Touch [RETURN] to return to the previous screen.

- *When the speaker is set to the "OFF" mode, the X-OVER for that speaker cannot be set. Refer to "Setting the Speakers" (page 44).*
- *Check the playback frequencies of the connected speakers before adjusting.*
- *In order to protect the speakers, there is no OFF setting for the subwoofer low pass filter (the slope remains the same).*
- *Even if Tweeter is selected for FRONT 1, the filter OFF (slope OFF) of the H.P.F. can be set. If the slope is set to OFF, speakers may be damaged. Take care with this setting.*

## Performing Time Correction Manually (TCR)

Because of the particular conditions inside the vehicle, there can be major differences in the distances between the various speakers and the listening position. It is possible to calculate the optimum correction values and eliminate the time error at the listening position yourself using this function.

### 1 Check that Defeat mode is off.

### 2 Sit in the listening position (the driver's seat, for example) and measure the distance (in meters) between your head and the various speakers.

### 3 Calculate the difference in distance between the farthest speaker and the other speakers.

$$L = \begin{array}{l} \text{(distance of farthest speaker)} \\ - \text{(distance of other speakers)} \end{array}$$

### 4 Divide the distances calculated for the different speakers by the speed of sound (343 m/s temperature 20°C).

This value is the time correction value for the various speakers.

#### **Concrete examples**

Calculating the time correction value for the front left speaker on the diagram below.

Conditions:

Distance between farthest speaker and listening position:  
2.25 m (88-3/4")

Distance between front left speaker and listening position:  
0.5 m (20")

Calculation:

$$L = 2.25 \text{ m (88-3/4")} - 0.5 \text{ m (20")} = 1.75 \text{ m (68-3/4")}$$
$$\text{Compensation time} = 1.75 \div 343 \times 1000 = 5.1 \text{ (ms)}$$

In other words, setting the time correction value for the front left speaker to 5.1 (ms) sets a virtual distance matching the distance to the farthest speaker.

*Continued*

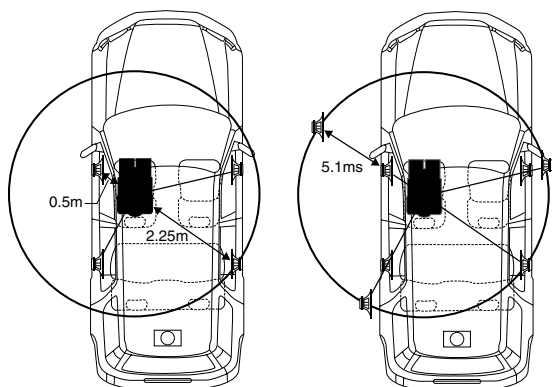

The sound is uneven because the distance between the listening position and the different speakers is different. The difference in the distance between the front left and rear right speakers is 1.75 meters (68-3/4").

Time correction eliminates the difference between the time required for the sound from the different speakers to reach the listening position. Setting the time correction of the front left speaker to 5.1 ms makes it possible to coordinate the distance from the listening position to the speaker.

- 5 Touch **[SYS.]** on the main source screen.  
The SYSTEM selection screen appears.
  - 6 Touch **[i-Personalize]**.  
The i-Personalize screen appears.
  - 7 Touch **[>>]** of **A.PROCESSOR**.  
The A.PROC list screen is displayed.
  - 8 Touch **[◀]** or **[▶]** of **T.CORR**.  
Select L/R or L+R.  
L/R: Different adjustment values can be set for the left and right channels.  
L+R: Sets the same adjustment values for the left and right channels.
  - 9 Touch **[>>]** of **T.CORR**.  
The T.CORR adjustment screen appears.
  - 10 Adjust the time correction value (0.0~20.0ms) of a desired speaker by touching the respective **[◀]** or **[▶]** button. (1step = 0.1ms)
  - 11 Touch **[RETURN]** to return to the previous screen.
- When the speaker is set to the "OFF" mode, the TCR for that speaker cannot be set. Refer to "Setting the Speakers" (page 44).
  - The adjustment value for FRONT2 (Speakers) which is adjusted in time correction, is also applied to the front speakers in "Setting Bass Focus" (page 47).
  - The adjustment (AUTO TCR) cannot be automatically set on this unit.

## Phase Switching

- 1 Make sure that the defeat is turned off (page 22).
- 2 Touch **[SYS.]** on the main source screen.  
The SYSTEM selection screen is displayed.
- 3 Touch **[i-Personalize]**.  
The i-Personalize screen appears.
- 4 Touch **[>>]** of **A.PROCESSOR**.  
The A.PROC list screen is displayed.
- 5 Touch **[>>]** of **PHASE**.  
The PHASE adjustment screen appears.
- 6 Switch the phase (0° or 180°) by touching **[◀]** or **[▶]** of the desired speaker.
- 7 Touch **[RETURN]** to return to the previous screen.

## Graphic Equalizer Adjustments

The graphic equalizer allows you to modify the sound using 31 bands each for the front (left and right), rear (left and right) and center speakers. An additional 10 bands are available for the subwoofer. This allows you to customize the sound to suit your taste.

- 1 Check that the Defeat mode is off.
- 2 Touch **[SYS.]** on the main source screen.  
The SYSTEM selection screen appears.
- 3 Touch **[i-Personalize]**.  
The i-Personalize screen will appear.
- 4 Touch **[>>]** of **A.PROCESSOR**.  
The A.PROC list screen appears.
- 5 Select L/R or L+R by touching **[◀]** or **[▶]** of **G-EQ**.  
L/R: Different adjustment values can be set for the left and right channels.  
L+R: Sets the same adjustment values for the left and right channels.  
When parametric EQ is adjusted, this setting will be turned off.
- 6 Touch **[>>]** of **G-EQ**.  
The G-EQ list screen appears.
- 7 Touch **[>>]** of the desired speaker (channel).  
The G-EQ adjustment screen appears.
- 8 Adjust the level by touching **[◀]** or **[▶]** of the desired frequency.
- 9 When adjusting another frequency, repeat steps 7 and 8 above.



## 10 Touch [RETURN] to return to the previous screen.

- When the speaker is set to the “OFF” mode, the graphic equalizer for that speaker cannot be set. Refer to “Setting the Speakers” (page 44).
- Check the playable frequency ranges of the connected speakers before making the equalizer adjustments. If the speaker’s playable frequency range is 55 Hz to 30 kHz, for example, adjusting the 40 Hz or 20 Hz band has no effect. Additionally, you may overload and damage the speakers.
- When graphic EQ is adjusted, the adjustment for parametric EQ becomes ineffective.

## Parametric Equalizer Adjustments

The frequency bands of the graphic equalizer are fixed. This makes it very difficult to correct for undesired peaks and dips at specific frequencies. The parametric equalizer’s center frequency can be tuned to these specific frequencies. Then, the bandwidth (Q) and level are fine-tuned, independently, to make the necessary corrections. The parametric equalizer function is an advanced tool for serious audiophiles.

- 1 Check that Defeat mode is off.**
- 2 Touch [SYS.] on the main source screen.**  
The SYSTEM selection screen appears.
- 3 Touch [i-Personalize].**  
The i-Personalize screen will appear.
- 4 Touch [>>] of A.PROCESSOR.**  
The A.PROC list screen appears.
- 5 Select L/R or L+R by touching [◀] or [▶] of P-EQ.**  
L/R: Different adjustment values can be set for the left and right channels.  
L+R: Sets the same adjustment values for the left and right channels.  
  
When graphic EQ is adjusted, this setting will be turned off.
- 6 Touch [>>] of P-EQ.**  
The P-EQ list screen appears.
- 7 Touch [>>] of the desired speaker (channel).**  
The P-EQ adjustment screen appears.
- 8 Touch the desired adjustment mode.**  
FREQ : Selects the frequency.  
LEVEL : Adjusts the level.  
Q : Adjust the band width.
- 9 Adjust the desired band by touching [◀] or [▶] of that band.**
- 10 When adjusting another band, repeat steps 7 to 9 above.**
- 11 Touch [RETURN] to return to the previous screen.**

- When the speaker is set to the “OFF” mode, the parametric equalizer for that speaker cannot be set. Refer to “Setting the Speakers” (page 44).
- It is not possible to adjust the frequencies of adjacent bands within 7 steps.
- Check the playable frequency ranges of the connected speakers before making the equalizer adjustments. If the speaker’s playable frequency range is 55 Hz to 30 kHz, for example, adjusting the 40 Hz or 20 Hz band has no effect. Additionally, you may overload and damage the speakers.
- When the parametric EQ is adjusted, the adjustment for graphic EQ becomes ineffective.

## Setting Bass Sound Control

- 1 Make sure that the defeat is turned off.**
- 2 Touch [SYS.] on the main source screen.**  
The SYSTEM selection screen is displayed.
- 3 Touch [i-Personalize].**  
The i-Personalize screen appears.
- 4 Touch [>>] of A.PROCESSOR.**  
The A.PROC list is displayed.
- 5 Touch [>>] of BASS SOUND CONT.**  
The Bass Sound Cont. screen appears.

## Setting Bass Compressor

You can adjust the sound of low frequencies as desired.

- 6 Touch [◀] or [▶] of BASS COMP. to select the desired mode.**  
Bass sound is emphasized more as the mode is sequentially switched as MODE1 → 2 → 3, offering you vivid low frequencies.  
Select OFF when the setting is not necessary.  
  
Touch [RETURN] to return to the previous screen.

## Setting Bass Focus

Using the previously specified delay number (time difference) allows you to set a time difference between the front-rear/left-right speakers. Namely, it enables a time correction based on your preference. With an initial delay of 0.10 ms for each of the 0 to 200 steps, audible time correction can be achieved.

- 6 Set the delay number in the front and rear, and on the right and left of the desired speaker by touching the respective [◀] or [▶] button.**
  - Any setting in Bass Focus is applied in time correction, too.
  - Touch [RETURN] to return to the previous screen.

## Speaker Setup

The PXA-H700 or PXA-H701 can be set according to the playable frequency range of your speakers.

Check the playable frequency range of the speakers (not including the subwoofer) before performing this operation to verify whether the speakers can play low frequencies (of about 80 Hz or less).

- *Avoid stopping, pausing, switching the disc, cueing, fast-forwarding or switching the audio channel of this unit while making this adjustment. The setting is canceled if Decode mode is switched.*

- 1 Check that Defeat mode is off (page 22).**
- 2 Touch [SYS.] on the main source screen.**  
The SYSTEM selection screen appears.
- 3 Touch [i-Personalize].**  
The i-Personalize screen will appear.
- 4 Touch [>>] of A.PROCESSOR.**  
The A.PROC list screen appears.
- 5 Touch [>>] of SPEAKER SETUP.**  
The adjusting screen of SPEAKER SETUP appears.
- 6 Select the speaker characteristic by touching [◀] or [▶] of the desired speaker setting.**

OFF\*1: When no speaker is connected.

SMALL: When a speaker that cannot play low frequencies (80 Hz or less) is connected.

LARGE\*2: When a speaker that can play low frequencies (80 Hz or less) is connected.

\*1 It is not possible to set the front speakers to "OFF".

\*2 If the front speakers are set to "SMALL", the rear and center speakers cannot be set to "LARGE".

- *If the center speaker is turned "OFF," the center channel's audio signals are added to the audio signals output from the front speakers.*
- *If you set the speaker response to "OFF," also set the speaker setting to "OFF" (page 44)*
- *Perform the setup for all the speakers ("Front," "Center," "Rear" and "Subwoofer"). If not, the sound may not be balanced.*
- *When center is set to "OFF," the setting is ineffective even if center is set with this function.*
- *Through changing the settings on each speaker, a change in the output of the other speakers may occur due to the setting requirements.*
- *When using the PRO LOGIC II, if the rear speaker is set to "LARGE", then there will be no output from the subwoofer.*

## Setting of Dolby 5.1ch

- 1 Check that Defeat mode is off.**
- 2 Touch [SYS.] on the main source screen.**  
The SYSTEM selection screen appears.
- 3 Touch [i-Personalize].**  
The i-Personalize screen will appear.
- 4 Touch [>>] of A.PROCESSOR.**  
The A.PROC list screen appears.
- 5 Touch [>>] of DOLBY 5.1 CH SETUP.**  
The DOLBY 5.1CH SETUP display appears.  
Set the items below as you desire.

### Adjusting the acoustic image

In most installations, the center speaker must be placed directly between the front passenger and driver. Using this function, the center channel information is distributed to the left and right speakers. This creates an acoustic image simulating a center speaker directly in front of each listener. Adjusting the center width in PL II MUSIC (see "Using the Pro Logic II Mode," page 50), makes this function ineffective.

- *Avoid stopping, pausing, switching the disc, cueing, fast-forwarding or switching the audio channel of this unit while making this adjustment. The setting is canceled if the Decode mode is switched.*

Touch [◀] or [▶] of BI - PHANTOM to adjust the level.

The level can be adjusted within the range of -5 to +5. The higher the level, the more the position of the center speaker is shifted to the sides.

The BI-PHANTOM function is turned off by touching [OFF].

- *This adjustment is effective when the setting of the center speaker to SMALL or LARGE in the speaker setup settings.*
- *This adjustment is ineffective when the speaker is set to CENTER OFF in "Setting the Speakers" (page 44).*

### Mixing bass sound to the rear channel

This function mixes the front channel audio signals to the audio signals output from the rear speakers, improving the sound in the vehicle's rear seat.

- *Avoid stopping, pausing, switching the disc, cueing, fast-forwarding or switching the audio channel of this unit while making this adjustment. The setting is canceled if the Decode mode is switched.*

Touch [◀] or [▶] of REAR MIX to adjust the level.

The level can be adjusted in five steps: -6, -3, 0, +3 and +6. The higher the level, the more bass is output from the rear speakers. (The effect differs according to the software (DVD, etc.).)

The REAR MIX function is turned off by touching [OFF].

- *This adjustment is ineffective when the rear speaker setup setting is set to "OFF"*
- *For linear PCM signals, the voice is output from the rear speaker regardless of the REAR FILL and REAR MIX setting.*

## Achieving powerful high volume sound

With Dolby Digital, the dynamic range is compressed so that powerful sound can be achieved at regular volume levels. This compression can be canceled to achieve an energetic sound with even greater power, like the sound in a movie theater.

This function works only in the Dolby Digital mode.

Touch [◀] or [▶] of LISTENING MODE to select STD or MAX.

STD: For powerful sound at regular volume levels

MAX: For powerful sound at high volumes

- *Keep the volume to a level at which sounds outside the vehicle can still be heard.*

## Adjusting the speaker levels

The test tones help to make the volume adjustments of the different speakers. When levels are equal, a strong sense of presence can be heard from the different speakers at the listening position.

- *Avoid stopping, pausing, switching the disc, cueing, fast-forwarding or switching the audio channel of this unit while making this adjustment. The setting is canceled if the decode mode is switched.*

1 Touch [ON] of OUTPUT LEVEL.

Test tone output is repeated for each of the different speaker channels. They will be repeated in the order shown below.

If no operation is performed for 2 seconds, the channel switches to the next channel.

Left → Center → Right → Right Surround →

Left surround → Left

2 While the test tone is being produced from the speakers, touch [◀] or [▶] of OUTPUT LEVEL balance the output from all the speakers.

- The adjustment range for the different speakers is -10 dB - +10 dB.
- Adjust based on the front speakers.

- *If a speaker is set to off mode, that speaker's level adjustment cannot be made.*  
*Refer to "Setting the Speakers" (page 44).*

## Adjusting the DVD Level

The volume (signal level) for Dolby Digital, Dolby PL II, DTS and PCM modes can be set.

- *Avoid stopping, pausing, switching the disc, cueing, fast-forwarding or switching the audio channel of this unit while making this adjustment. The setting is canceled if the Decode mode is switched.*

**1** Check that Defeat mode is off.

**2** Touch [SYS.] on the main source screen.

The SYSTEM selection screen appears.

**3** Touch [i-Personalize].

The i-Personalize screen will appear.

**4** Touch [➤➤] of A.PROCESSOR.

The A.PROC list screen appears.

**5** Touch [➤➤] of DVD LEVEL.

The DVD LEVEL list screen appears.

**6** Adjust the level by touching [◀] or [▶] of the desired adjusting mode.

The level can be adjusted in the range of -5 to +5.

## Storing Settings in the Memory

Adjustment or setting contents can be stored.

Contents that can be stored vary depends on the audio processor used.

**1** Check that Defeat mode is off.

**2** Touch [MEMORY] on the A.PROC list display.

**3** Within 5 seconds, touch any one of the preset buttons [P.SET 1] through [P.SET 6] on the A.PROC list screen.

The setting contents are stored.

- *The stored contents will not be deleted even when the battery power cord is detached.*

## Getting out the Preset Memory

**1** Check that Defeat mode is off.

**2** Touch any one of the preset buttons [P.SET 1] through [P.SET 6] on the A.PROC list display to select the preset memory.

- *It takes a few moment to get out the preset memory.*

---

## Using the Pro Logic II Mode

---

Pro Logic processing can be conducted on the music signals recorded on two channels to achieve Dolby Pro Logic II surround sound. For two-channel Dolby Digital and DTS signals, there is also a "REAR FILL" function for outputting the signals of the front channel to the rear channel.

- 1 Check that Defeat mode is off (page 22).**
- 2 Touch [SYS.] on the main source screen.**  
The SYSTEM selection screen appears.
- 3 Touch [i-Personalize].**  
The i-Personalize screen will appear.
- 4 Touch [>>] of A.PROCESSOR.**  
The A.PROC list screen appears.
- 5 Touch [>>] of DOLBY PLII.**  
The DOLBY PLII adjusting screen appears.
- 6 Touch [◀] or [▶] of DOLBY PLII to select the desired mode.**

### PL II MOVIE:

Suits the stereo TV shows and all programs encoded in Dolby Surround. It improves the sound field directivity to near that of discrete 5.1-channel sound.

### PL II MUSIC:

Can be used for all stereo music recordings, and provides a wide, deep sound field.

### REAR FILL:

Depending on the input signals, the sound may only be output from the front speakers. In this case, the "REAR FILL" function can be used to output signals from the rear speakers as well.

OFF: Turns DOLBY PL II function to OFF.

### ***If PL II MUSIC is selected, the center width can be adjusted with following operations.***

This function offers the optimum vocal position by adjusting the center channel position between the center speaker and the L/R speaker. (The adjustments established in "Adjusting the acoustic image" (page 48) are ineffective while this function is activated.)

Touch [◀] or [▶] of CENTER WIDTH CONT to adjust the level.

The level can be adjusted between 0 to 7. When the level increases, the center channel position moves from the center speaker position to both sides.

Touch [OFF] of CENTER WIDTH CONT to turn off the center width control.

- This adjustment is effective when the setting of the center speaker is SMALL or LARGE in the speaker setup settings.*
- Avoid stopping, pausing, switching the disc, cueing, fast-forwarding or switching the audio channel of this unit while making this adjustment. The setting is canceled if the Decode mode is switched.*
- This adjustment is ineffective when the speaker is set to CENTER OFF in "Setting the Speakers" (page 44).*
- This function only works with two-channel signals. This operation is ineffective when 5.1-channel DTS or Dolby Digital signals are input.*
- If the setting of REAR FILL is made when REAR MIX is ON, sound is unchanged in the rear fill setting because REAR MIX is given priority during 2 channel decoder other than linear PCM.*
- For linear PCM signals, the voice is output from the rear speaker regardless of the REAR FILL and REAR MIX setting.*

---

## Linear PCM Setting

---

The output when playing discs recorded in linear PCM can be set to 2 or 3 channels.

- 1 Check that Defeat mode is off.**
- 2 Touch [SYS.] on the main source screen.**  
The SYSTEM selection screen appears.
- 3 Touch [i-Personalize].**  
The i-Personalize screen will appear.
- 4 Touch [>>] of A.PROCESSOR.**  
The A.PROC list screen appears.
- 5 Touch [◀] or [▶] of PCM MODE to select 2 CH or 3 CH.**  
  
2CH: 2ch output (L/R)  
3CH: 3ch output (L/R/CENTER)  
  
*• This adjustment is ineffective when the speaker is set to CENTER OFF in "Setting the Speakers" (page 44).*

# Navigation System (Optional)

## Switching the Navigation Screen (Optional)

If an optional Alpine Navigation System is connected to the IVA-D300, the Navigation screen can be displayed on this unit.

### 1 Touch **[SRC]** on the main source screen.

The source screen appears on the display.

### 2 Touch **[NAV]**.

The Navigation screen is displayed.

The operation is possible with the supplied navigation remote control.

For navigation operation, refer to the Owner's Manual of the navigator.

- When **V. SEL** is pressed while the Navigation selection mode is being selected in "Setting Visual Mode" (page 33), the navigation mode will be directly activated.
- If the Navigation mode menu is not displayed on the main menu screen, set **NAV. IN** to on by following "Setting the navigation Mode" (page 32).
- When the Navigation System is on, the audio and visual navigation cuts in.

# Auxiliary Device (Optional)

## Operating Auxiliary Devices (Optional)

To operate your devices connected to the AUX terminals on the rear panel of IVA-D300, follow the procedure described below.

### **WARNING**

It is dangerous (and illegal in many states) for the driver to watch the TV/Video while driving the vehicle. The driver may be distracted from looking ahead and an accident could occur.

Install the IVA-D300 correctly so that the driver cannot watch TV/Video unless the vehicle is stopped and the emergency brake is applied.

If the IVA-D300 is not installed correctly, the driver will be able to watch the TV/Video while driving the vehicle and may be distracted from looking ahead and cause an accident. The driver or other people could be severely injured.

### **To activate your auxiliary devices:**

To watch a video source, your vehicle must be parked with the ignition key in the ACC or ON position. To do this, follow the procedure below.

1. Bring your vehicle to a complete stop at a safe location. Engage the parking brake.
2. Keep pushing the foot brake and release the parking brake once then engage it again.
3. When the parking brake is engaged for the second time, release the foot brake.

- For automatic transmission vehicles, place the transmission lever in the Park position.

Now, the locking system for the AUX mode operation has been released. Engaging the parking brake can reactivate the AUX mode, as long as the car's ignition has not been turned off. It is not necessary to repeat the above procedure (1 through 3), of "To activate your auxiliary devices."

Each time the ignition is turned OFF, perform the procedure of "To activate your auxiliary devices."

- If you try to activate the auxiliary device while driving, the display will show the warning-**PICTURE OFF FOR YOUR SAFETY**.

### 1 Touch **[SRC]** on the main source screen.

The source screen appears on the display.

### 2 Touch **[AUX]**\*.

The external input screen is displayed.

\* *AUX-1 to AUX-3 are displayed if the external input devices (maximal 3) are connected, or the name which is given as the source name in "Naming External Devices" on page 33 is displayed.*

- If the AUX mode is not displayed on the main menu, set **AUX IN** to ON by following "Setting the AUX Mode" (page 33).
- The display mode changes by touching **[WIDE]**.  
For operation, refer to "Switching Display Modes" on page 24.

# Changer (Optional)

## Controlling CD Changer (Optional)

An optional 6-disc or 12-disc CD Changer may be connected to the IVA-D300 if it is Ai-NET compatible. With a CD Changer connected to the Ai-NET input of the IVA-D300, the CD Changer will be controllable from the IVA-D300.

If you connect a changer compatible with MP3, you can play CD-ROMs, CD-Rs, and CD-RWs containing MP3 files on the IVA-D300.

Using the KCA-400C (the Multi-Changer Switching device) multiple changers can be controlled by the IVA-D300.

See the Multi-Changer Selection section for selecting the CD Changers (explained on this page).

**1 Touch [SRC] on the main source screen.**

**2 Touch [CD CHG].**

The display changes to the CD changer mode screen.

**When a 6 Disc CD Changer is connected;**

1 Touch [P1/2]\*.

The Function Guide display appears.

\* *When an MP3 compatible CD changer or DVD changer is connected, touch repeatedly until the disc number is displayed.*

2 Touch any one of the select buttons [DISC 1] through [DISC 6].

DISC 1 through DISC 6 select the discs from the first disc to 6th disc.

**When an MP3 compatible CD changer is connected;**

1 Touch [P1/3] twice to change the Function Guide display.

2 Touch any one of the select buttons [DISC 1] through [DISC 6].

DISC 1 through DISC 6 select the discs from the first disc to 6th disc.

**When a 12-Disc CD Changer is connected;**

You can select the disc numbers 1 to 6 in the same manner as for 6-disc Changer.

Touch [P1/3] twice to select disc numbers 7 to 12.

The function guide display changes so that DISC 7 through DISC 12 represent disc numbers 7 to 12.

- *After selecting the desired disc, you can operate in the same way as for the CD player. For details, see the CD/MP3/WMA section*
- *When an MP3 compatible CD changer is connected, the unit can play discs containing both audio data and MP3 data.*
- *The DVD changer (optional) is controllable from the IVA-D300 as well as the CD changer.*

## Multi-Changer Selection (Optional)

Alpine's Ai-NET system will support up to 6 CD Changers. When operating two or more changers, the KCA-400C (Multi-Changer Switching device) must be used. If you use 1 Switching device, you can connect up to 4 CD Changers. If you use 2 Switching devices, you can connect up to 6 CD Changers. When using KCA-410C (Versatile Link Terminal), you can connect two changers only.

**1 In changer mode, touch [CHG SEL] or press BAND on the unit to select the next changer (connected changers only) .**

**2 To operate the selected changer, see "CD/MP3/WMA" section.**

- *To operate the selected changer, see "CD/MP3/WMA" (pages 14 and 15).*

# HDD Player Operation (Optional)

## Listening to Music of HDD

This device is controllable from the unit when Alpine HDD player is connected.

- 1 Touch [SRC] on the main source screen.**  
The source selection screen appears.
- 2 Touch [MM DRIVER].**  
The MM DRIVER mode main screen appears.
- 3 Select the desired music by touching [◀◀] or [▶▶].**  
Searching: Touch [◀◀] or [▶▶].  
Fast-forward/reverse: Touch and hold [◀◀] or [▶▶].
- 4 Touch [▶/II] to temporarily stop the music currently playing.**  
Touch [▶/II] again to resume the play.

# XM Radio (Optional)

## Receiving XM Channels with the XM Receiver (Optional)

XM Satellite Radio\* is the next generation of audio entertainment, with up to 100 brand-new digital channels. For a small monthly fee, subscribers can hear crystal-clear music, sports, news and talk, coast-to-coast via satellite. For more information, visit XM's website at [www.xmradio.com](http://www.xmradio.com) or call 1-800-852-9696.

An optional XM Satellite Radio Receiver (TUA-T021XM) and an optional XM Antenna may be connected to the IVA-D300. With an XM Receiver connected to the Ai-NET input of the IVA-D300, the XM Receiver will be controllable from the IVA-D300.

\* XM and its corresponding logos are trademarks of XM Satellite Radio Inc.

- The controls on the IVA-D300 for XM Receiver operation are operative only when an XM Receiver is connected.

- 1 Touch [SRC] on the main source screen.**  
The source selection screen is displayed.
- 2 Touch [XM].**  
The XM main screen display appears.
- 3 Touch [BAND] to select XM1, XM2 or XM3.**
- 4 Touch [NO./NAME] to select the channel number tuning.**  
Each time it is pressed, the tuning mode is changed.  
channel number tuning ↔ channel name tuning
- 5 Touch [◀ CH NO.] or [CH NO. ▶] to select the desired channel. Holding either button down will change channels continuously.**  
When selecting the channel name tuning in step 4, select a channel name by touching [◀ CH NAME] or [CH NAME ▶]. Holding either button down will change channel names continuously.

---

## Tuning in to Categorized Programs

---

You can listen to programs categorized to the same group one after another.

**1** In the XM mode, touch [**◀CAT DN**] or [**CAT UP▶**] once to activate the Category mode.

The "CATEGORY" indicator lights.

**2** While in the category mode, touch [**◀CAT DN**] or [**CAT UP▶**] again to select a desired category.

The first channel of the selected category is tuned.

- In category mode, activate channel UP/DOWN to select a channel in the current category by touching [**◀CH NO.**] or [**CH NO.▶**].
- To cancel the Category mode, touch [**NO./NAME**] or [**P1/3**]. This mode is automatically canceled after 13 seconds.
- If the desired category program is not found, the selected category is displayed for 5 seconds, then the receiving program is restored.

---

## Changing the Display

---

Text information, such as the channel name, artist name/feature, and song/program title, is available with each XM channel. The unit can display this text information as explained below.

In XM mode, touch [**INFO.**].

Each time you touch this button, the display changes as shown below.

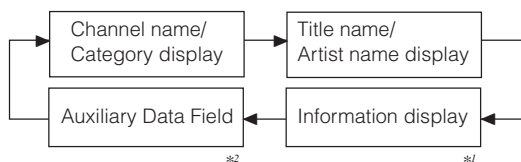

\*1 Channel number, category, title name, etc., are displayed in one screen.

\*2 The information display appears when ON is set in "Setting the Auxiliary Data Field Display" (page 31).

- Auxiliary Data Field is not displayed in the dual screen.

---

## Checking the XM Radio ID Number

---

You need to provide XM with the unique XM Radio ID number for your XM Radio Receiver in order to subscribe to XM's programming.

This number is an 8 character alphanumeric number that is printed on a label directly on the XM Receiver.

It can also be displayed on the screen of the IVA-D300 in the following way.

**1** While receiving XM1/XM2 or XM3, touch [**◀CH NO.**] or [**CH NO.▶**] to select channel "0."

**2** The unit displays the ID number.

**3** To cancel the ID number display, set the channel to other than "0."

- You cannot use "O," "S," "I," or "F" for the ID Number.
- You can check your ID number printed on the label on the package of your XM Satellite Radio Receiver (TUA-T021XM).

---

## Storing XM Channel Presets

---

**1** Touch [**P1/3**] after selecting a desired band.

The Function Guide is switched.

**2** Touch [**MEMORY**].

**3** Touch any one of the preset buttons [**P.SET 1**] through [**P.SET 6**] within 5 seconds into which you want to store the channel. The selected channel is stored.

**4** Repeat the procedure to store up to 5 other channels onto the same band.

To use this procedure for other bands, simply select the desired band and repeat the procedure.

A total of 18 channels can be stored in the preset memory (6 channels for each band; XM1, XM2 and XM3).

- If you store a channel in a preset already being used, the current channel will be replaced with the new one.

---

## Receiving Stored XM Channels

---

**1** Touch [**P1/3**] after selecting a desired band.

The Function Guide is switched.

**2** Touch any one of the preset buttons [**P.SET 1**] through [**P.SET 6**] that has your desired satellite channel in memory.



## Displaying the Category/Channel Name Title List

- In XM mode, touch [☐].**  
The category title list is displayed.

Screen example for category search list

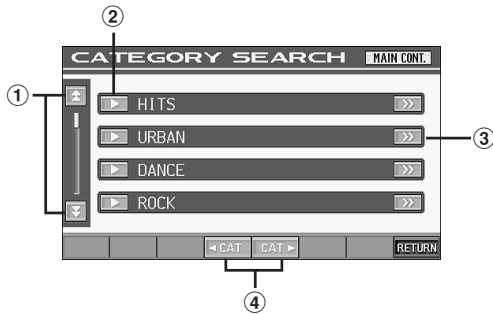

- Turns the page
- Touch [▶] to receive the selected category channel directly.
- [>>>] is displayed if there is a hierarchical list. Touch [>>>] to change the channel name search screen of the selected category.
- Category UP/DOWN can directly be performed.

Screen example for channel name search list

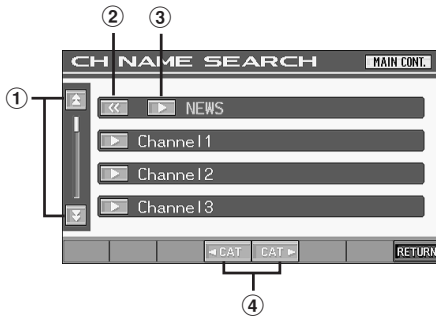

- Turns the page
- Returns to the category search list.
- The selected channel is received.
- Category UP/DOWN can directly be performed.

- Touch [▶] of the selected Category or Channel name.**

The channel in the selected category is tuned.

## Selecting the Channel directly

You can directly select the channel number on the display of the numeric keypad.

- Touch [P1/3] twice in the XM mode.**  
The function guide appears.
- Touch [10KEY].**  
The numeric keypad input screen is displayed.
- Touch to input the channel number.**
- Touch [ENT].**  
The selected channel is received.

# MobileHub™ Link (Optional)

## About MobileHub™ Link (Optional)

Connect a separately sold junction box and a portable telephone (available from Nokia) to control the incoming and outgoing calls of the portable telephone.

### CAUTION

- Even with hands-free operation, a driver can be distracted during telephone operation or receiving a call. For the sake of safety, drivers are requested to refrain from operating the telephone while driving.
- For the sake of safety, operations other than incoming calls and Speed-Dial outgoing calls cannot be used.

- If a portable telephone is connected, its address book, incoming and outgoing history, short message history and standardized sentences are downloaded to the junction box. Please refer to the instruction manual of the junction box.
- When a portable telephone is not connected, "NO PHONE" is displayed for at least 5 seconds, then the mode returns to the original source mode.
- When the portable telephone is taken off the junction box during an incoming or outgoing call, or during a hands-free call, the call will be treated as an ordinary one by the portable telephone.
- When there is an incoming call while the power of the IVA-D300 is OFF, the power of the IVA-D300 turns ON automatically, hands-free call is cut, and the portable telephone call is enabled.
- Even if the power of the portable telephone is OFF, when IVA-D300 is set to the telephone mode, the power of the portable telephone will be turned ON.
- If the ACC power of the vehicle is turned OFF (the engine is stopped) during a hands-free call, the hands-free call cuts, and the portable telephone call is enabled.
- If there is an incoming call during operation (except an outgoing call or talking), operation mode will end and switch to the incoming or talking mode.
- An outgoing call from a portable telephone is also possible. However, you cannot perform different operations at the same time from a portable telephone and IVA-D300 as malfunction can result.
- With a junction box connected outgoing, incoming, and sending history will also be recorded in the portable telephone.
- While telephoning, Time Correction is set to normal (0.0ms) and DEFEAT is also set to ON. When the call has finished, the unit returns to the setting which you previously set.
- The telephone volume can be adjusted from the IVA-D300. The volume you set during the call is memorized, and is automatically applied again on the next call.

## Telephone Reception

- 1 When this unit receives a call, the screen is switched to RINGING display of Telephone mode.
- 2 When AUTO call (setting of AUTO/MANUAL call page 31) is selected, CONNECT display appears and this unit enters AUTO call mode in 3 seconds after receiving.
- 3 To cut the call, touch . Or the call is automatically cut in 5 seconds after finishing. The screen returns to the previous source mode.



### To input any number or symbol during call:

- 1 Touch [10KEY] in the CONNECT display. The numeric keypad screen is displayed.
- 2 Touch and input a desired number or symbol.
- 3 Touch [RTN] to return to the previous screen.
- 4 Touch  to start a call.

## Calling



### Calling by using the Speed Dial

You can place a call by retrieving one of the telephone numbers registered in No. 1 to 9 of the address book.

- 1 Touch  on the main source screen. The Speed Dial and the numeric keypad displays appear.
- 2 Touch any one of the buttons [1] through [9] in which the telephone numbers are recorded.
  - A call is sent directly by touching and holding any one of the recorded buttons [1] to [9] for at least 2 seconds.
- 3 Touch  to start call.
- 4 To cut the call, touch . Or the call is automatically cut in 5 seconds after finishing.
  - If no telephone number is registered in the selected function button, "NO PRESET" is displayed for 5 seconds. Touch [RETURN] to return to the Telephone menu.
  - When [SPEED DIAL] is touched in the Telephone menu display, the Speed Dial display appears.

### Dial call

Input the telephone number using the dial.

- 1 Touch  on the main source screen. The Speed Dial display appears.
- 2 Touch [RTN] on the numeric keypad input screen to close the numeric keypad screen. The Telephone menu display appears.
- 3 Touch [DIRECT CALL]. The Direct Call and numeric keypad displays appear.
- 4 Touch and input the telephone number.
- 5 Touch [ENT].
- 6 Touch  to start call.
  - The call is cut in 5 seconds after "NO NETWORK COVERAGE" is displayed.

### To listen to the answer-phone or to input numbers:

- 1 In the CONNECT display, touch [10KEY]. The Dial Sending and numeric keypad displays appear.
- 2 Touch and input a desired number or symbol.
- 3 Touch [RTN] to return to the previous screen.





- 7 To cut the call, touch . Or the call is automatically cut in 5 seconds after finishing. The screen returns to the previous source mode.

- If [RETURN] is touched within 5 seconds of cutting the call, the Telephone menu display appears.
- When the call is cut, touching  dials the number again.

### Calling by the address book

From your vehicle, call from the address book registered in the portable telephone.

The operation may be carried out only when vehicle is parked.

- 1 Touch  on the main source screen. The Speed Dial display appears.
- 2 Touch [RTN] on the numeric keypad input screen to close the numeric keypad screen. The Telephone menu display appears.
- 3 Touch [PHONE BOOK]. The Phone Book list appears.
- 4 Touch [CALL] of a desired addressee on the list.
  - By touching  or , the names are listed in alphabetical order.
  - If no data is in the PHONE BOOK, "NO MEMORY" is displayed. Touch [RETURN] to return to the Telephone menu display.
- 5 Touch  to place the call.
- 6 To cut the call, touch . Or the call is automatically cut in 5 seconds after finishing.

### Calling by the outgoing / incoming / absent incoming history

You can place a call to one of the last 999 calls by the outgoing/incoming/absent incoming history.

- 1 Touch  on the main source screen. The Speed Dial display appears.
- 2 Touch [RTN] on the numeric keypad input screen to close the numeric keypad screen. The Telephone menu display appears.
- 3 Touch any one of the buttons [DIALED CALL], [MISSED CALL] or [RECEIVED CALL].
  - DIALED CALL: Outgoing history list display
  - MISSED CALL: Absent incoming history list display
  - RECEIVED CALL: Incoming history list display
  - If no history is registered to any of the lists, "NO MEMORY" is displayed. To return to Telephone menu display, touch [RETURN].

- 4 Touch **[CALL]** of a desired addressee on the list.
- 5 Touch **[📞]** to start call.
- 6 To cut the call, touch **[📞]**. Or the call is automatically cut in 5 seconds after finishing.

## SMS (Short Message Service) Operation

You can receive messages, show the contents of messages, and send standardized sentences.

When a message is received, an icon is indicated on the display.

### Receiving a Short message

- 1 Touch **[📞]** on the main source screen.  
The Speed Dial display appears.
- 2 Touch **[RTN]** on the numeric keypad input screen to close the numeric keypad screen.  
The Telephone menu display appears.
- 3 Touch **[SMS READ]**.  
The SMS Read display appears.
- 4 Touch **[READ]** of the received short message.  
The SMS Inbox display appears.  
The contents of the received message is displayed up to 140 letters.  
Touch **[RETURN]** to return to the SMS Read display.

- When the unit receives a message, the new reception icon appears.

# Information

## About DVDs

Music CDs and DVDs have grooves (tracks) in which the digital data is recorded. The data is represented as microscopic pits recorded into the track – these pits are read by a laser beam to play the disc. On DVDs, the density of the tracks and pits is twice that of CDs, so DVDs can contain more data in less space.

### CDs

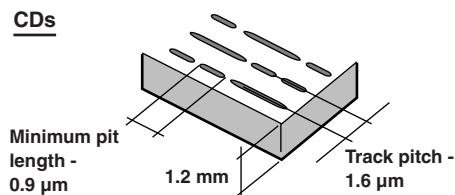

### DVDs

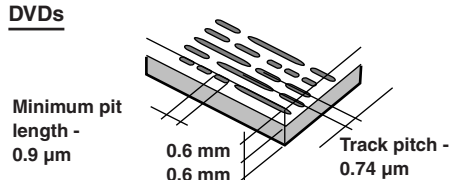

A 12 cm disc can contain one movie or about four hours of music.

In addition, DVDs provide sharp picture quality with vivid colors thanks to a horizontal resolution of over 500 lines (compared to less than 300 for VHS tape). With the addition of an optional, digital audio processor (PXA-H900/PXA-H510/PXA-H700, etc.), you can recreate the power and presence of a movie theater with Dolby Digital 5.1-channel Surround.

### In addition, DVDs offer a variety of functions.

- **Multiple audio\* (page 21)**  
Movies can be recorded in up to eight languages. The desired language can be selected from the remote control unit.
- **Subtitles function\* (page 21)**  
Movies can include subtitles in up to 32 languages. The desired subtitle language can be selected from the remote control unit.
- **Multi angle function\* (page 21)**  
When the DVD contains a movie shot from multiple angles, the desired angle can be selected from the remote control unit.
- **Multi story function\***  
With this function, a single movie includes various story lines. You can select different story lines to view various versions of the same movie.  
Operation differs from disc to disc. Story line selection screens including instructions appear during the movie. Just follow the instructions.

\* The functions audio languages, subtitle languages, angles, etc., differ from disc to disc. For details, refer to the disc's instructions.



## List of Language Codes

(For details, see page 28.)

Abbreviation	Code	Language	Abbreviation	Code	Language	Abbreviation	Code	Language
AA	6565	Afar	IE	7369	Interlingue	RN	8278	Kirundi
AB	6566	Abkhazian	IK	7375	Inupiak	RO	8279	Romanian
AF	6570	Afrikaans	IN	7378	Indonesian	RU	8285	Russian
AM	6577	Amharic	IS	7383	Icelandic	RW	8287	Kinyarwanda
AR	6582	Arabic	IT	7384	Italian	SA	8365	Sanskrit
AS	6583	Assamese	IW	7387	Hebrew	SD	8368	Sindhi
AY	6589	Aymara	JA	7465	Japanese	SG	8371	Sangho
AZ	6590	Azerbaijani	JI	7473	Yiddish	SH	8372	Serbo-Croatian
BA	6665	Bashkir	JW	7487	Javanese	SI	8373	Singhalese
BE	6669	Byelorussian	KA	7565	Georgian	SK	8375	Slovak
BG	6671	Bulgarian	KK	7575	Kazakh	SL	8376	Slovenian
BH	6672	Bihari	KL	7576	Greenlandic	SM	8377	Samoan
BI	6673	Bislama	KM	7577	Cambodian	SN	8378	Shona
BN	6678	Bengali, Bangla	KN	7578	Kannada	SO	8379	Somali
BO	6679	Tibetan	KO	7579	Korean	SQ	8381	Albanian
BR	6682	Breton	KS	7583	Kashmiri	SR	8382	Serbian
CA	6765	Catalan	KU	7585	Kurdish	SS	8383	Siswati
CO	6779	Corsican	KY	7589	Kirghiz	ST	8384	Sesotho
CS	6783	Czech	LA	7665	Latin	SU	8385	Sundanese
CY	6789	Welsh	LN	7678	Lingala	SV	8386	Swedish
DA	6865	Danish	LO	7679	Laothian	SW	8387	Swahili
DE	6869	German	LT	7684	Lithuanian	TA	8465	Tamil
DZ	6890	Bhutani	LV	7686	Latvian, Lettish	TE	8469	Telugu
EL	6976	Greek	MG	7771	Malagasy	TG	8471	Tajik
EN	6978	English	MI	7773	Maori	TH	8472	Thai
EO	6979	Esperanto	MK	7775	Macedonian	TI	8473	Tigrinya
ES	6983	Spanish	ML	7776	Malayalam	TK	8475	Turkmen
ET	6984	Estonian	MN	7778	Mongolian	TL	8476	Tagalog
EU	6985	Basque	MO	7779	Moldavian	TN	8478	Setswana
FA	7065	Persian	MR	7782	Marathi	TO	8479	Tonga
FI	7073	Finnish	MS	7783	Malay	TR	8482	Turkish
FJ	7074	Fiji	MT	7784	Maltese	TS	8483	Tsonga
FO	7079	Faroese	MY	7789	Burmese	TT	8484	Tatar
FR	7082	French	NA	7865	Nauru	TW	8487	Twi
FY	7089	Frisian	NE	7869	Nepali	UK	8575	Ukrainian
GA	7165	Irish	NL	7876	Dutch	UR	8582	Urdu
GD	7168	Scots Gaelic	NO	7879	Norwegian	UZ	8590	Uzbek
GL	7176	Galician	OC	7967	Occitan	VI	8673	Vietnamese
GN	7178	Guarani	OM	7977	(Afan) Oromo	VO	8679	Volapuk
GU	7185	Gujarati	OR	7982	Oriya	WO	8779	Wolof
HA	7265	Hausa	PA	8065	Punjabi	XH	8872	Xhosa
HI	7273	Hindi	PL	8076	Polish	YO	8979	Yoruba
HR	7282	Croatian	PS	8083	Pashto, Pushto	ZH	9072	Chinese
HU	7285	Hungarian	PT	8084	Portuguese	ZU	9085	Zulu
HY	7289	Armenian	QU	8185	Quechua			
IA	7365	Interlingua	RM	8277	Rhaeto-Romance			

## List of Country Codes

(For details, see page 28.)

Abbreviation	Code	Country	Abbreviation	Code	Country	Abbreviation	Code	Country
AD	6568	Andorra	DM	6877	Dominica	KI	7573	Kiribati
AE	6569	United Arab Emirates	DO	6879	Dominican Republic	KM	7577	Comoros
AF	6570	Afghanistan	DZ	6890	Algeria	KN	7578	Saint Kitts and Nevis
AG	6571	Antigua and Barbuda	EC	6967	Ecuador	KP	7580	Korea, Democratic People's Republic of
AI	6573	Anguilla	EE	6969	Estonia			
AL	6576	Albania	EG	6971	Egypt	KR	7582	Korea, Republic of
AM	6577	Armenia	EH	6972	Western Sahara	KW	7587	Kuwait
AN	6578	Netherlands Antilles	ER	6982	Eritrea	KY	7589	Cayman Islands
AO	6579	Angola	ES	6983	Spain	KZ	7590	Kazakistan
AQ	6581	Antarctica	ET	6984	Ethiopia	LA	7665	Lao People's Democratic Republic
AR	6582	Argentina	FI	7073	Finland			
AS	6583	American Samoa	FJ	7074	Fiji	LB	7666	Lebanon
AT	6584	Austria	FK	7075	Falkland Islands	LC	7667	Saint Lucia
AU	6585	Australia	FM	7077	Micronesia, Federated States of	LI	7673	Liechtenstein
AW	6587	Aruba	FO	7079	Faroe Islands	LK	7675	Sri Lanka
AZ	6590	Azerbaijan	FR	7082	France	LR	7682	Liberia
BA	6665	Bosnia and Herzegovina	GA	7165	Gabon	LS	7683	Lesotho
BB	6666	Barbados	GB	7166	United Kingdom	LT	7684	Lithuania
BD	6668	Bangladesh	GD	7168	Grenada	LU	7685	Luxembourg
BE	6669	Belgium	GE	7169	Georgia	LV	7686	Latvia
BF	6670	Burkina Faso	GF	7170	French Guiana	LY	7689	Libyan Arab Jamahiriya
BG	6671	Bulgaria	GH	7172	Ghana	MA	7765	Morocco
BH	6672	Bahrain	GI	7173	Gibraltar	MC	7767	Monaco
BI	6673	Burundi	GL	7176	Greenland	MD	7768	Moldova, Republic of
BJ	6674	Benin	GM	7177	Gambia	MG	7771	Madagascar
BM	6677	Bermuda	GN	7178	Guinea	MH	7772	Marshall Islands
BN	6678	Brunei Darussalam	GP	7180	Guadeloupe	MK	7775	Macedonia, The former Yugoslav Republic of
BO	6679	Bolivia	GQ	7181	Equatorial Guinea			
BR	6682	Brazil	GR	7182	Greece	ML	7776	Mali
BS	6683	Bahamas	GS	7183	South Georgia and the South Sandwich Islands	MM	7777	Myanmar
BT	6684	Bhutan				MN	7778	Mongolia
BV	6686	Bouvet Island	GT	7184	Guatemala	MO	7779	Macau
BW	6687	Botswana	GU	7185	Guam	MP	7780	Northern Mariana Islands
BY	6689	Belarus	GW	7187	Guinea-Bissau	MQ	7781	Martinique
BZ	6690	Belize	GY	7189	Guyana	MR	7782	Mauritania
CA	6765	Canada	HK	7275	Hong Kong	MS	7783	Montserrat
CC	6767	Cocos (Keeling) Islands	HM	7277	Heard Island and McDonald Islands	MT	7784	Malta
CD	6768	Congo, the Democratic Republic of the	HN	7278	Honduras	MU	7785	Mauritius
CF	6770	Central African Republic	HR	7282	Croatia	MV	7786	Maldives
CG	6771	Congo	HT	7284	Haiti	MW	7787	Malawi
CH	6772	Switzerland	HU	7285	Hungary	MX	7788	Mexico
CI	6773	Cote d'Ivoire	ID	7368	Indonesia	MY	7789	Malaysia
CK	6775	Cook Islands	IE	7369	Ireland	MZ	7790	Mozambique
CL	6776	Chile	IL	7376	Israel	NA	7865	Namibia
CM	6777	Cameroon	IN	7378	India	NC	7867	New Caledonia
CN	6778	China	IO	7379	British Indian Ocean Territory	NE	7869	Niger
CO	6779	Colombia	IQ	7381	Iraq	NF	7870	Norfolk Island
CR	6782	Costa Rica	IR	7382	Iran, Islamic Republic of	NG	7871	Nigeria
CU	6785	Cuba	IS	7383	Iceland	NI	7873	Nicaragua
CV	6786	Cape Verde	IT	7384	Italy	NL	7876	Netherlands
CX	6788	Christmas Island	JM	7477	Jamaica	NO	7879	Norway
CY	6789	Cyprus	JO	7479	Jordan	NP	7880	Nepal
CZ	6790	Czech Republic	JP	7480	Japan	NR	7882	Nauru
DE	6869	Germany	KE	7569	Kenya	NU	7885	Niue
DJ	6874	Djibouti	KG	7571	Kyrgyzstan	NZ	7890	New Zealand
DK	6875	Denmark	KH	7572	Cambodia	OM	7977	Oman
						PA	8065	Panama

Abbreviation	Code	Country	Abbreviation	Code	Country	Abbreviation	Code	Country
PE	8069	Peru	SJ	8374	Svalbard and Jan Mayen	TW	8487	Taiwan, Province of China
PF	8070	French Polynesia	SK	8375	Slovakia	TZ	8490	Tanzania, United Republic of
PG	8071	Papua New Guinea	SL	8376	Sierra Leone	UA	8565	Ukraine
PH	8072	Philippines	SM	8377	San Marino	UG	8571	Uganda
PK	8075	Pakistan	SN	8378	Senegal	UM	8577	United States Minor Outlying Islands
PL	8076	Poland	SO	8379	Somalia	US	8583	United States
PM	8077	Saint Pierre and Miquelon	SR	8382	Suriname	UY	8589	Uruguay
PN	8078	Pitcairn	ST	8384	Sao Tome and Principe	UZ	8590	Uzbekistan
PR	8082	Puerto Rico	SV	8386	El Salvador	VA	8665	Holy See (Vatican City State)
PT	8084	Portugal	SY	8389	Syrian Arab Republic	VC	8667	Saint Vincent and the Grenadines
PW	8087	Palau	SZ	8390	Swaziland	VE	8669	Venezuela
PY	8089	Paraguay	TC	8467	Turks and Caicos Islands	VG	8671	Virgin Island, British
QA	8165	Qatar	TD	8468	Chad	VI	8673	Virgin Islands, U.S
RE	8269	Reunion	TF	8470	French Southern Territories	VN	8678	Viet Nam
RO	8279	Romania	TG	8471	Togo	VU	8685	Vanuatu
RU	8285	Russian Federation	TH	8472	Thailand	WF	8770	Wallis and Futuna
RW	8287	Rwanda	TJ	8474	Tajikistan	WS	8783	Samoa
SA	8365	Saudi Arabia	TK	8475	Tokelau	YE	8969	Yemen
SB	8366	Solomon Islands	TM	8477	Turkmenistan	YT	8984	Mayotte
SC	8367	Seychelles	TN	8478	Tunisia	YU	8985	Yugoslavia
SD	8368	Sudan	TO	8479	Tonga	ZA	9065	South Africa
SE	8369	Sweden	TP	8480	East Timor	ZM	9077	Zambia
SG	8371	Singapore	TR	8482	Turkey	ZW	9087	Zimbabwe
SH	8372	Saint Helena	TT	8484	Trinidad and Tobago			
SI	8373	Slovenia	TV	8486	Tuvalu			

## In Case of Difficulty

If you encounter a problem, please turn the power off, then on again. If the unit is still not functioning normally, please review the items in the following checklist. This guide will help you isolate the problem if the unit is at fault. Otherwise, make sure the rest of your system is properly connected, or then consult your authorized Alpine dealer.

### Basic

#### No function or display.

- Vehicle's ignition is off.
  - If connected according to the instructions, the unit will not operate with the vehicle's ignition off.
- Improper power lead connections.
  - Check power lead connections.
- Blown fuse.
  - Check the fuse on the battery lead of the unit; replace with the proper value if necessary.
- Internal micro-computer malfunctioned due to interference noise, etc.
  - Press the RESET switch with a ballpoint pen or other pointed article.
- Blackout mode is activated.
  - Cancel Blackout mode.

#### No sound or unnatural sound.

- Incorrect setting of volume/balance/fader controls.
  - Readjust the controls.
- Connections are not properly or securely made.
  - Check the connections and firmly connect.

#### Screen not displayed.

- Brightness control is set at the minimum position.
  - Adjust the Brightness control.
- Temperature in the vehicle is too low.
  - Increase the vehicle's interior temperature to operation temperature range.
- Connections to the DVD, CD player, navigation system are not securely made.
  - Check the connections and firmly connect.

#### Movement of displayed picture is abnormal.

- Temperature in the vehicle is too high.
  - Allow the vehicle's interior temperature to cool.

#### Unclear or noisy display.

- Fluorescent plate is worn out.
  - Replace the fluorescent plate.

#### Navigation system inoperative.

- Connections to the navigation system are incorrect.
  - Check the connections with the navigation system and connect the cables correctly and firmly.

#### Unclear picture display.

- Fluorescent tube is exhausted.
  - Replace the fluorescent tube\*.

\* The fluorescent tube replacement is not free of charge even within the warranty period, for the tube is an article of consumption.

### Radio

#### Unable to receive stations.

- No antenna, or open connection in the antenna cable.
  - Make sure the antenna is properly connected; replace the antenna or cable if necessary.

#### Unable to tune stations in the seek mode.

- You are in a weak signal area.
  - Make sure the tuner is in DX mode.
- If the area you are in is a primary signal area, the antenna may not be grounded and connected properly.
  - Check your antenna connections; make sure the antenna is properly grounded at its mounting location.
- The antenna may not be the proper length.
  - Make sure the antenna is fully extended; if broken, replace the antenna with a new one.

#### Broadcast is noisy.

- The antenna is not the proper length.
  - Extend the antenna fully; replace it if it is broken.
- The antenna is poorly grounded.
  - Make sure the antenna is grounded properly at its mounting location.
- The station signal is weak and noisy.
  - If above solution does not work, tune in another station.

### CD/MP3/WMA/DVD/Video CD

#### Disc playback sound is wavering.

- Moisture condensation in the disc Module.
  - Allow enough time for the condensation to evaporate (about 1 hour).

#### Disc insertion not possible.

- A disc is already in the DVD player.
  - Eject the disc and remove it.
- The disc is being improperly inserted.
  - Make sure the disc is being inserted following the instructions in the CD (MP3/WMA/DVD/Video CD) Player Operation section.

#### Unable to fast forward or backward the disc.

- The disc has been damaged.
  - Eject the disc and discard it; using a damaged disc in your unit can cause damage to the mechanism.

#### Disc playback sound skips due to vibration.

- Improper mounting of the unit.
  - Securely re-mount the unit.
- Disc is very dirty.
  - Clean the disc.
- Disc has scratches.
  - Change the disc.
- The pick-up lens is dirty.
  - Do not use a commercial available lens cleaner disc. Consult your nearest ALPINE dealer.

#### Disc playback sound skips without vibration.

- Dirty or scratched disc.
  - Clean the disc; damaged disc should be replaced.

#### CD-R/CD-RW playback not possible.

- Close session (finalization) has not been performed.
  - Perform finalization and attempt playback again.



### Error displays

- Mechanical error
  - Press **▲**. After the error indication disappears, insert the disc again. If the above-mentioned solution does not solve the problem, consult your nearest ALPINE dealer.

### MP3/WMA is not played back.

- Writing error occurred. The CD format is not compatible.
  - Make sure the CD has been written in a supported format. Refer to "About MP3/WMA" (pages 15 and 16), then rewrite in the format supported by this device.

### Unit does operate.

- Monitor's power is not turned on.
  - Turn on the monitor's power.
- Condensation.
  - Wait a while (about 1 hour) for the condensation to dry.

### No picture is produced.

- Monitor's mode is not switched to the mode you want to see.
  - Switch to the mode you want to see.
- Monitor's parking brake lead is not connected.
  - Connect the monitor's parking brake lead and set the parking brake.  
(For details, refer to the monitor's instructions.)
- Monitor's parking brake is not set.
  - Connect the monitor's parking brake lead and set the parking brake.  
(For details, refer to the monitor's instructions.)

### Playback does not start.

- Disc is loaded upside-down.
  - Check the disc and load it with the labeled side facing upward.
- Disc is dirty.
  - Clean the disc.
- A disc not able to playback with this unit is loaded.
  - Check if the disc is able to be played back.
- Parental lock is set.
  - Cancel the parental lock or change the rating level.

### Picture is unclear or noisy.

- Disc is being fast-forwarded or fast-reversed.
  - The picture may be slightly disturbed, but this is normal.
- Vehicle's battery power is weak.
  - Check the battery power and wiring.  
(The unit may malfunction if the battery power is under 11 volts with a load applied.)
- Monitor's fluorescent tube is worn.
  - Replace the monitor's fluorescent tube.

### Image stops sometimes.

- Disc is scratched.
  - Replaced with a non-scratched disc.

## Indication for CD/MP3/WMA

### HI-TEMP

- Protective circuit is activated due to high temperature.
  - The indicator will disappear when the temperature returns to within operation range.
  - Leave the power OFF until the temperature decreases and then turn the power ON again.

### NO DISC

- No disc is inserted.
  - Insert a disc.
- Although a disc is inserted, "NO DISC" is displayed and the unit does not start to play or eject the disc.
  - Remove the disc by following these steps:  
Press **▲** for at least 3 seconds.

### LOADING ERROR

### EJECT ERROR

- Mechanism error.
  - 1) Press **▲** and eject the disc.  
If not ejecting, consult your Alpine dealer.
  - 2) When the error indication remains after ejecting, press **▲** again.  
If the error indication still does not turn off after pressing **▲** for a few times, consult your Alpine dealer.

### DISC ERROR

- Scratched disc, contaminated disc/poor recording/disc incompatible with this unit
  - Press **▲**.
  - Change the disc.

## Indication for DVD/Video CD

### NO DISC

- No disc is inserted.
  - Insert a disc.
- Although a disc is inserted, "NO DISC" is displayed and the unit does not start to play or eject the disc.
  - Remove the disc by following these steps:  
Press **▲** for at least 3 seconds.



- Remote control operation is not possible.
  - For some discs or playing modes, certain operations are not possible. This is not a malfunction.

### HI-TEMP

- Protective circuit is activated to high temperature.
  - The indicator will disappear when the temperature returns to within operation range.
  - Leave the power OFF until the temperature decreases and then turn the power ON again.

### VIDEO SIGNAL SYSTEM IS NOT CORRECT

- PAL disc is loaded.
  - Load an NTSC disc

Continued

### LOADING ERROR

### EJECT ERROR

- Mechanism error.
  - 1) Press **▲** and eject the disc.  
If not ejecting, consult your Alpine dealer.
  - 2) When the error indication remains after ejecting, press **▲** again.  
If the error indication still does not turn off after pressing **▲** for a few times, consult your Alpine dealer.

### DISC ERROR

- Scratched disc, contaminated disc/poor recording/disc incompatible with this unit
  - Press **▲**.
  - Change the disc.

## Indication for CD changer

### HI-TEMP

- Protective circuit is activated due to high temperature.
  - The indicator will disappear when the temperature returns to within operation range.

### ERROR01

- Malfunction in the CD Changer.
  - Consult your Alpine dealer. Press the magazine eject button and pull out the magazine.  
Check the indication. Insert the magazine again.  
If the magazine cannot be pulled out, consult your Alpine dealer.
- Magazine ejection not possible.
  - Press the magazine eject button. If the magazine does not eject, consult your Alpine dealer.

### ERROR02

- A disc is left inside the CD Changer.
  - Press the Eject button to activate the eject function. When the CD Changer finishes the eject function, insert an empty CD magazine into the CD Changer to receive the disc left inside the CD Changer.

### NO MAGAZINE

- No magazine is loaded into the CD Changer.
  - Insert a magazine.

### NO DISC

- No indicated disc.
  - Choose another disc.

## Indication for XM radio mode

### ANTENNA

- The XM antenna is not connected to the XM radio module.
  - Check whether the XM antenna cable is attached securely to the XM radio module.

### UPDATING

- Radio is being updated with latest encryption code.
  - Wait until encryption code is being updated. Channels 0 and 1 should function normally.

### NO SIGNAL

- XM signal is too weak at the current location.
  - Wait until the car reaches a location with a stronger signal.

### LOADING

- Radio is acquiring audio or program information.
  - Wait until the radio has received the information.

### OFF AIR

- The channel currently selected has stopped broadcasting.
  - Select another channel.

-----

- The user has selected a Channel Number that does not exist or is not subscribed to.
  - The unit will revert back to the previously selected channel.
- There is no artist name/feature, song/program title, or Auxiliary Data Field associated with the channel at that time.
  - No action needed.

## **Specifications**

### **MONITOR SECTION**

Screen Size	7.0"
LCD Type	Transparent type TN LCD
Operation System	TFT active matrix
Number of Picture Elements	336,960 pcs. (1,440 × 234)
Effective Number of Picture Elements	99.99% or more
Illumination System	Cold cathode fluorescent tube

### **FM TUNER SECTION**

Tuning Range	87.7 – 107.9 MHz
Mono Usable Sensitivity	9.3 dBf (0.8 $\mu$ V/75 ohms)
50 dB Quieting Sensitivity	13.5 dBf (1.3 $\mu$ V/75 ohms)
Alternate Channel Selectivity	80 dB
Signal-to-Noise Ratio	80 dB
Stereo Separation	45 dB
Capture Ratio	2.0 dB

### **AM TUNER SECTION**

Tuning Range	530 – 1,710 kHz
Usable Sensitivity	22.5 $\mu$ V/27.0 dB

### **CD/DVD SECTION**

Frequency Response	5 – 20,000 Hz
Wow & Flutter (% WRMS)	Below measurable limits
Total Harmonic Distortion	0.008% (at 1 kHz)
Dynamic Range	95 dB (at 1 kHz)
Channel Separation	85 dB (at 1 kHz)
Signal system	NTSC
Horizontal resolution	500 lines or greater
Video output level	1Vp-p (75 ohms)
Video S/N ratio	DVD: 60 dB
Audio S/N ratio	More than 105 dB

### **PICKUP**

Wave length	
DVD:	665 nm
CD:	800 nm
Laser power	CLASS I

### **GENERAL**

Power Requirement	14.4 V DC (11–16 V allowable)
Operating temperature	+32°F to +113°F (0°C to +45°C)
Power Output	18 W RMS × 4*
* Primary amplifier ratings per CEA-2006 Standard	
• Power output: measured at 4 Ohms and $\leq$ 1% THD+N	
• S/N: 80 dBA (reference: 1 W into 4 Ohms)	
Output Voltage	2,000 mV/10k ohms (Monitor Section) 2.1 kg
Weight	(4 lbs. 10 oz) (Tuner Section) 1.2 kg (2 lbs. 10 oz)
Audio output level	
Preout (Front, Rear):	2V/10k ohms (max.)
Preout (Subwoofer):	2V/10k ohms (max.)
Auxout:	1.2V/10k ohms
Ai-NET:	850 mV

### **CHASSIS SIZE (Monitor section)**

Width	178 mm (7")
Height	50 mm (2")
Depth	165 mm (6-1/2")

### **CHASSIS SIZE (Tuner section)**

Width	275 mm (10-13/16")
Height	40 mm (1-9/16")
Depth	170 mm (6-3/4")

- *Due to continuous product improvement, specifications and design are subject to change without notice.*
- *The LCD panel is manufactured using an extremely high precision manufacturing technology. Its effective pixel ratio is over 99.99%. This means that there is a possibility that 0.01% of the pixels could be either always ON or OFF.*

---

---

# Installation and Connections

Before installing or connecting the unit, please read the following and pages 4 to 6 of this manual thoroughly for proper use.

## Warning

---

### MAKE THE CORRECT CONNECTIONS.

Failure to make the proper connections may result in fire or product damage.

---

### USE ONLY IN CARS WITH A 12 VOLT NEGATIVE GROUND.

(Check with your dealer if you are not sure.) Failure to do so may result in fire, etc.

---

### BEFORE WIRING, DISCONNECT THE CABLE FROM THE NEGATIVE BATTERY TERMINAL.

Failure to do so may result in electric shock or injury due to electrical shorts.

---

### DO NOT ALLOW CABLES TO BECOME ENTANGLED IN SURROUNDING OBJECTS.

Arrange wiring and cables in compliance with the manual to prevent obstructions when driving. Cables or wiring that obstruct or hang up on places such as the steering wheel, gear lever, brake pedals, etc. can be extremely hazardous.

---

### DO NOT SPLICE INTO ELECTRICAL CABLES.

Never cut away cable insulation to supply power to other equipment. Doing so will exceed the current carrying capacity of the wire and result in fire or electric shock.

---

### DO NOT DAMAGE PIPE OR WIRING WHEN DRILLING HOLES.

When drilling holes in the chassis for installation, take precautions so as not to contact, damage or obstruct pipes, fuel lines, tanks or electrical wiring. Failure to take such precautions may result in fire.

---

### DO NOT USE BOLTS OR NUTS IN THE BRAKE OR STEERING SYSTEMS TO MAKE GROUND CONNECTIONS.

Bolts or nuts used for the brake or steering systems (or any other safety-related system), or tanks should NEVER be used for installations or ground connections. Using such parts could disable control of the vehicle and cause fire etc.

---

### KEEP SMALL OBJECTS SUCH AS BOLTS OR SCREWS OUT OF THE REACH OF CHILDREN.

Swallowing them may result in serious injury. If swallowed, consult a physician immediately.

---

### DO NOT INSTALL IN LOCATIONS WHICH MIGHT HINDER VEHICLE OPERATION, SUCH AS THE STEERING WHEEL OR GEARSHIFT.

Doing so may obstruct forward vision or hamper movement etc. and results in serious accident.

---

## Caution

---

### HAVE THE WIRING AND INSTALLATION DONE BY EXPERTS.

The wiring and installation of this unit requires special technical skill and experience. To ensure safety, always contact the dealer where you purchased this product to have the work done.

---

### USE SPECIFIED ACCESSORY PARTS AND INSTALL THEM SECURELY.

Be sure to use only the specified accessory parts. Use of other than designated parts may damage this unit internally or may not securely install the unit in place. This may cause parts to become loose resulting in hazards or product failure.

---

### ARRANGE THE WIRING SO IT IS NOT CRIMPED OR PINCHED BY A SHARP METAL EDGE.

Route the cables and wiring away from moving parts (like the seat rails) or sharp or pointed edges. This will prevent crimping and damage to the wiring. If wiring passes through a hole in metal, use a rubber grommet to prevent the wires insulation from being cut by the metal edge of the hole.

---

### DO NOT INSTALL IN LOCATIONS WITH HIGH MOISTURE OR DUST.

Avoid installing the unit in locations with high incidence of moisture or dust. Moisture or dust that penetrates into this unit may result in product failure.

---

## Precautions

- Be sure to disconnect the cable from the (-) battery post before installing your IVA-D300. This will reduce any chance of damage to the unit in case of a short-circuit.
- Be sure to connect the color coded leads according to the diagram. Incorrect connections may cause the unit to malfunction or damage to the vehicle's electrical system.
- When making connections to the vehicle's electrical system, be aware of the factory installed components (e.g. on-board computer). Do not tap into these leads to provide power for this unit. When connecting the IVA-D300 to the fuse box, make sure the fuse for the intended circuit of the IVA-D300 has the appropriate amperage. Failure to do so may result in damage to the unit and/or the vehicle. When in doubt, consult your ALPINE dealer.
- The IVA-D300 uses female RCA-type jacks for connection to other units (e.g. amplifier) having RCA connectors. You may need an adaptor to connect other units. If so, please contact your authorized ALPINE dealer for assistance.
- Be sure to connect the speaker (-) leads to the speaker (-) terminal. Never connect left and right channel speaker cables to each other or to the vehicle body.
- The Display must be completely retracted in the casing when installing. If it is not, problems may occur.
- When installing in automobiles, make sure the Display can open/close without coming in contact with the gear shift .

---

## IMPORTANT

Please record the serial number of your unit in the space provided below and keep it as a permanent record. The serial number plate is located on the bottom of the unit.

SERIAL NUMBER: \_\_\_\_\_  
INSTALLATION DATE: \_\_\_\_\_  
INSTALLATION TECHNICIAN: \_\_\_\_\_  
PLACE OF PURCHASE: \_\_\_\_\_

# Installation

## Installing the Monitor

### Installation Location

Before deciding on the mounting location, check that opening and closing the display will not hamper gear shifting in that position.

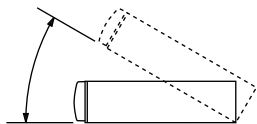

- Install at an angle of within 30 degrees from the horizontal.
- The monitor's angle is set to 90 degrees at the factory. Depending on the car, the monitor may hit the dashboard when opened. The monitor's angle can be adjusted and stored in memory so that the monitor will not hit the dashboard when opening. For adjusting the monitor, refer to "Adjusting the monitor Angle" on page 26. Even when the vehicle's battery power is removed, the adjusted monitor angle remains stored in memory.

1

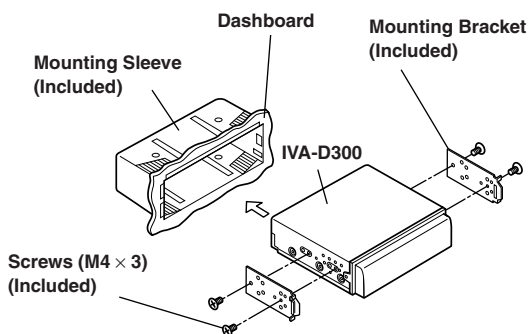

Slide the mounting sleeve into the dashboard. Install the supplied bracket on the monitor.

- Make sure to use the supplied screw (M4 x 3) to install the monitor. If you use another screw to install the monitor, it may cause a malfunction.

2

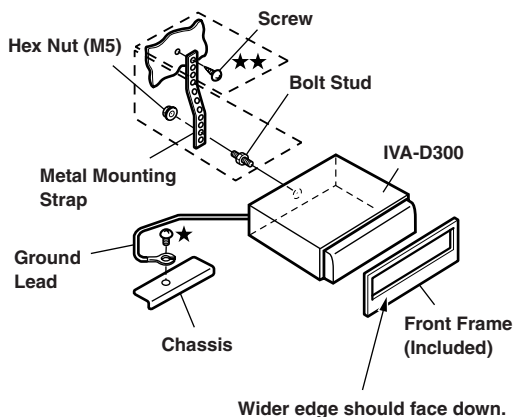

Reinforce the monitor unit with a metal mounting strap (not supplied). Secure the ground lead of the unit to a clean metal spot using a screw (★) already attached to the vehicle's chassis.

- For the screw marked ★★, use an appropriate screw for the chosen mounting location.

Connect each input lead coming from an amplifier or equalizer to the corresponding output lead coming from the left rear of the IVA-D300. Connect all other leads of the IVA-D300 according to details described in the Connections section.

3

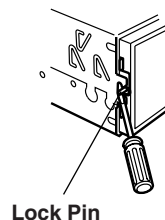

Slide the IVA-D300 into the dashboard. When the unit is in place, make sure the locking pins are fully seated in the down position. This can be done by pressing firmly in on the unit while pushing the locking pin down with a small screwdriver. This ensures that the unit is properly locked and will not accidentally come out from the dashboard. Install the supplied Front Frame.

### Removal

1. Use a small screwdriver (or similar tool) to push the locking pins to the "up" position (see Step 3). As each pin is unlocked, gently pull out on the unit to make sure it does not re-lock before unlocking the second pin.
2. Pull the unit out, keeping it unlocked as you do so.

### < JAPANESE CAR >

To install using the vehicle's standard bracket.

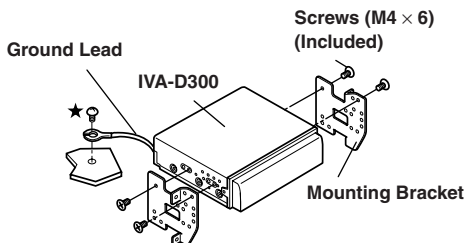

- Make sure to use the supplied screw (M4 x 6) to install the monitor. If you use another screw to install the monitor, it may cause a malfunction.

## Installing the Tuner Box

### Caution

Do not block the unit's fan or heat sink, thus preventing air circulation. If blocked, heat will accumulate inside the unit and may cause a fire.

Air ventilation hole

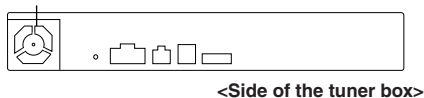

### When mounting with Velcro fasteners

When mounting the tuner with the Velcro fasteners, be sure to choose a flat location.

Do not hang the unit from the bottom of the dashboard or rear deck with the Velcro fasteners.

- 1 Remove the Protective paper and attach two pieces of Velcro fastener to the bottom of the Tuner.

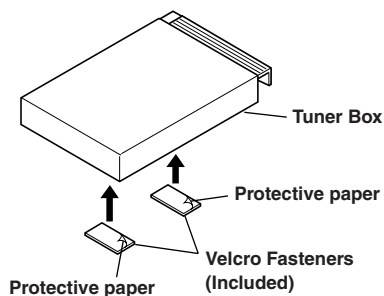

- 2 Check the position, and then fix the Tuner to the floor carpet.

### When mounting with Screws

When mounting the tuner with the screws, be sure to choose a flat location.

When making holes, be careful not to scratch any pipes or wires.

- 1 Connect the bracket to both the flanks of the tuner with the supplied pan screws (M4 × 8).

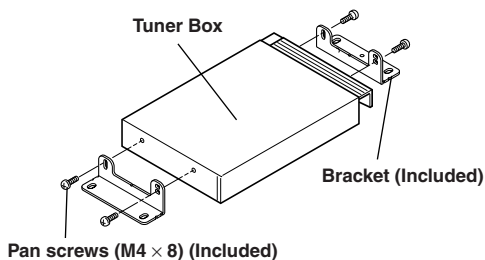

- 2 Install the tuner on the floor with the supplied flange-head tapping screws (M4 × 14).

Flange-head tapping screws (M4 × 14) (Included)

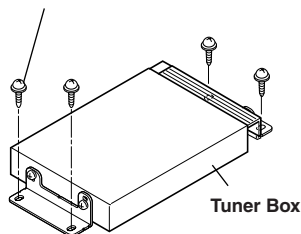

## Installing the DC/DC Converter

Install the DC/DC Converter on the floor with the supplied flange-head tapping screws (M4 × 14).

Flange-head tapping screws (M4 × 14) (Included)

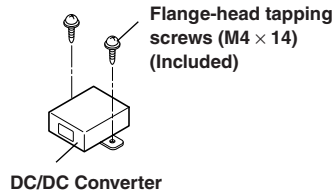

## Parking Brake Lead Connection

If necessary, use a pinch connector to connect the foot brake lead, parking brake lead, etc.

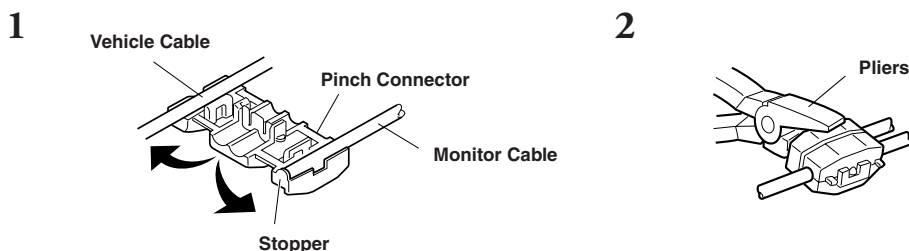

## Foot Brake Lead / Parking Brake Lead Connection

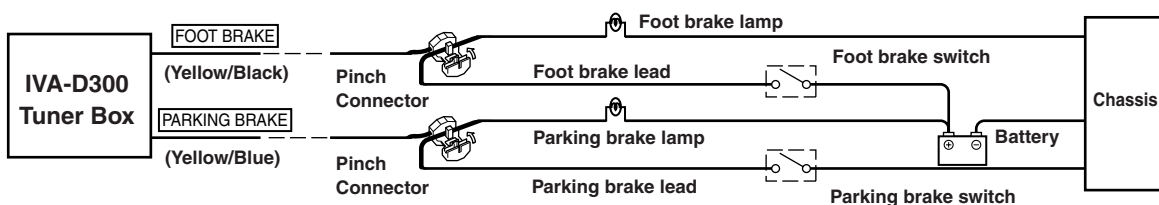

## Connection Diagram of SPST Switch (Sold Separately)

(If the ACC power supply is not available)

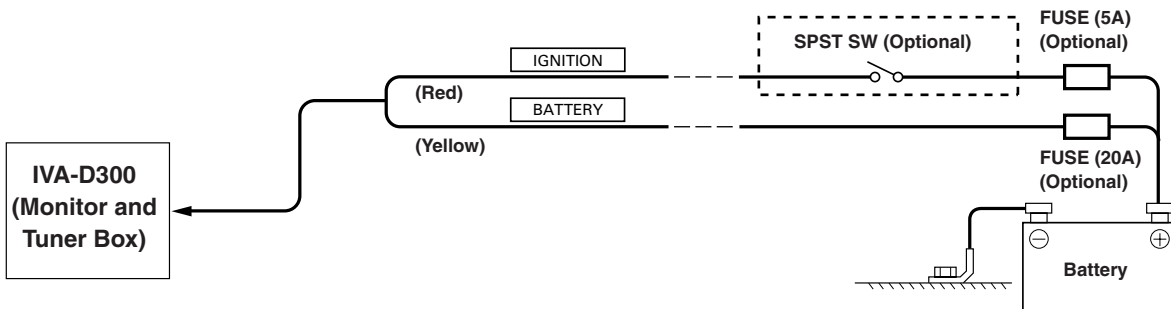

- If your vehicle has no ACC power supply, add an SPST (Single-Pole, Single-Throw) switch (sold separately) and fuse (sold separately).
- The diagram and the fuse amperage shown above are in the case when IVA-D300 is used individually.
- If the switched power (ignition) lead of the IVA-D300 is connected directly to the positive (+) post of the vehicle's battery, the IVA-D300 draws some current (several hundred milliamperes) even when its switch is placed in the OFF position and the battery may be discharged.

### To prevent external noise from entering the audio system.

- Locate the unit and route the leads at least 10 cm away from the car harness.
- Keep the battery power leads as far away from other leads as possible.
- Connect the ground lead securely to a bare metal spot (remove any paint, dirt or grease if necessary) of the car chassis.
- If you add an optional noise suppressor, connect it as far away from the unit as possible. Your Alpine dealer carries various noise suppressors, contact them for further information.
- Your Alpine dealer knows best about noise prevention measures so consult your dealer for further information.

# Connections (IVA-D300 Wiring Diagram)

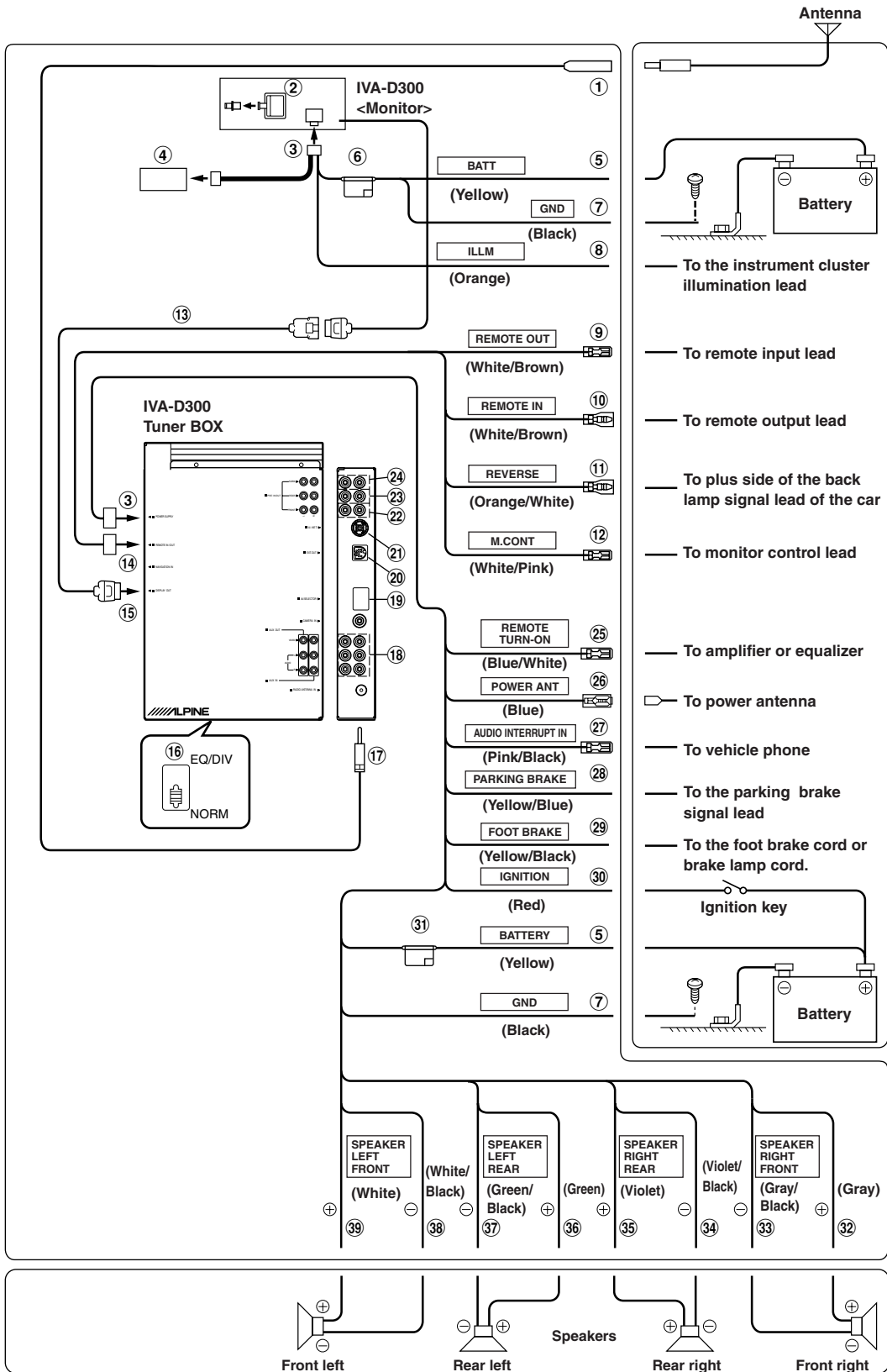

• Set the system switch to "NORM" when only a changer is connected (when the Ai-NET compatible equalizer is not used).



- ① **Antenna Extension Cable**
- ② **Digital Output Terminal (Optical)**  
Use when combining fiber digital input compatible products.
- ③ **Power Supply Connector**
- ④ **DC/DC Converter**
  - Do not install the converter at a location subjected to water such as under the floor mat or air conditioner. This may cause a malfunction.
  - Do not bundle the DC/DC converter cable with other audio cables. Also, do not install the cables directly next to the unit. Doing so may induce noise into your system.
  - Keep the DC/DC converter away from the Antenna cables and the rear side of the unit, otherwise noise may be generated when receiving radio broadcast.
- ⑤ **Battery Lead (Yellow)**  
Connect this lead to the positive (+) post of the vehicle's battery.
- ⑥ **Fuse Holder (10A)**
- ⑦ **Ground Lead (Black)**  
Connect this lead to a good chassis ground on the vehicle. Make sure the connection is made to bare metal and is securely fastened using the sheet metal screw provided.
- ⑧ **Illumination Lead (Orange)**  
This lead may be connected to the vehicle's instrument cluster illumination lead. This will allow the backlighting of the IVA-D300 to dim whenever the vehicle's lights are turned on.
- ⑨ **Remote Control Output Lead (White/Brown)**  
Connect this lead to the remote control input lead. This lead outputs the controlling signals from the remote control.
- ⑩ **Remote Control Input Lead (White/Brown)**  
Connect the external Alpine product to the remote control output lead.
- ⑪ **Reverse Lead (Orange/White)**  
Use only when a back-up camera is connected. Connect to the plus side of the car's reverse lamp that lights when the transmission is shifted into reverse (R). Switches the video picture to the back-up camera. This is linked with putting the car into reverse (R).
- ⑫ **Monitor Control Lead (White/Pink)**  
Connect this to the Monitor Control Lead of the touch panel-compatible rear monitor.
- ⑬ **Monitor Extension Cable (Included)**
- ⑭ **Remote IN/OUT Terminal**
- ⑮ **Display Output Terminal**
- ⑯ **System Switch**  
When connecting an equalizer or divider using Ai-NET feature, place this switch in the EQ/DIV position. When no device is connected, leave the switch in the NORM position.
  - Be sure to turn the power off to the unit before changing the switch position.
- ⑰ **Antenna Receptacle**
- ⑱ **AUX Input Terminals/AUX Output Terminals**  
If these terminals are connected to the optional expansion box (VPE-S431), the AUX input and output terminals are not used on this unit. Connect AUX IN 1, 2 and 3, and the AUX OUT 1 and 2 terminals of the expansion box (VPE-S431) to the external device(s).
- ⑲ **AV Select Connector**  
When this connector is connected to the optional expansion box (VPE-S431), connect this to the HEAD UNIT terminal of VPE-S431.
- ⑳ **Ext. Output Connector**  
If this connector is connected to the optional Amplifier Link compatible monaural Amplifier, connect this to the optional Amplifier Link Box, and output the Amplifier Link control signal.
- ㉑ **Ai-NET Connector**  
Connect this to the output or input connector of other product (CD changer, Equalizer, etc.) equipped with Ai-NET.
- ㉒ **Front input/output Terminal**  
Use when connecting an amplifier or Equalizer.
- ㉓ **Rear input/output Terminal**  
Use when connecting an amplifier or Equalizer.
- ㉔ **Subwoofer output Terminal**  
Connect the input lead of an amplifier for the subwoofer to this terminal.
- ㉕ **Remote Turn-On Lead (Blue/White)**  
Connect this lead to the remote turn-on lead of your amplifier or signal processor.
- ㉖ **Power Antenna Lead (Blue)**  
Connect this lead to the +B terminal of your power antenna, if applicable.
- ㉗ **Audio Interrupt In Lead (Pink/Black)**
- ㉘ **Parking Brake Lead (Yellow/Blue)**  
Connect this lead to the power supply side of the parking brake switch to transmit the parking brake status signals to the IVA-D300.
- ㉙ **Foot Brake Lead (Yellow/Black)**  
Connect to the vehicle's foot brake lead or brake lamp lead.
- ㉚ **Switched Power Lead (Ignition) (Red)**  
Connect this lead to an open terminal on the vehicle's fuse box or another unused power source which provides (+) 12V only when the ignition is turned on or in the accessory position.
- ㉛ **Fuse Holder (10A)**
- ㉜ **Right Front (+) Speaker Output Lead (Gray)**
- ㉝ **Right Front (-) Speaker Output Lead (Gray/Black)**
- ㉞ **Right Rear (-) Speaker Output Lead (Violet/Black)**
- ㉟ **Right Rear (+) Speaker Output Lead (Violet)**
- ㊱ **Left Rear (+) Speaker Output Lead (Green)**
- ㊲ **Left Rear (-) Speaker Output Lead (Green/Black)**
- ㊳ **Left Front (-) Speaker Output Lead (White/Black)**
- ㊴ **Left Front (+) Speaker Output Lead (White)**

## System Example

Connect the Ai-NET compatible audio processor (Fiber digital compatible), Navigation system, DVD player and changer.

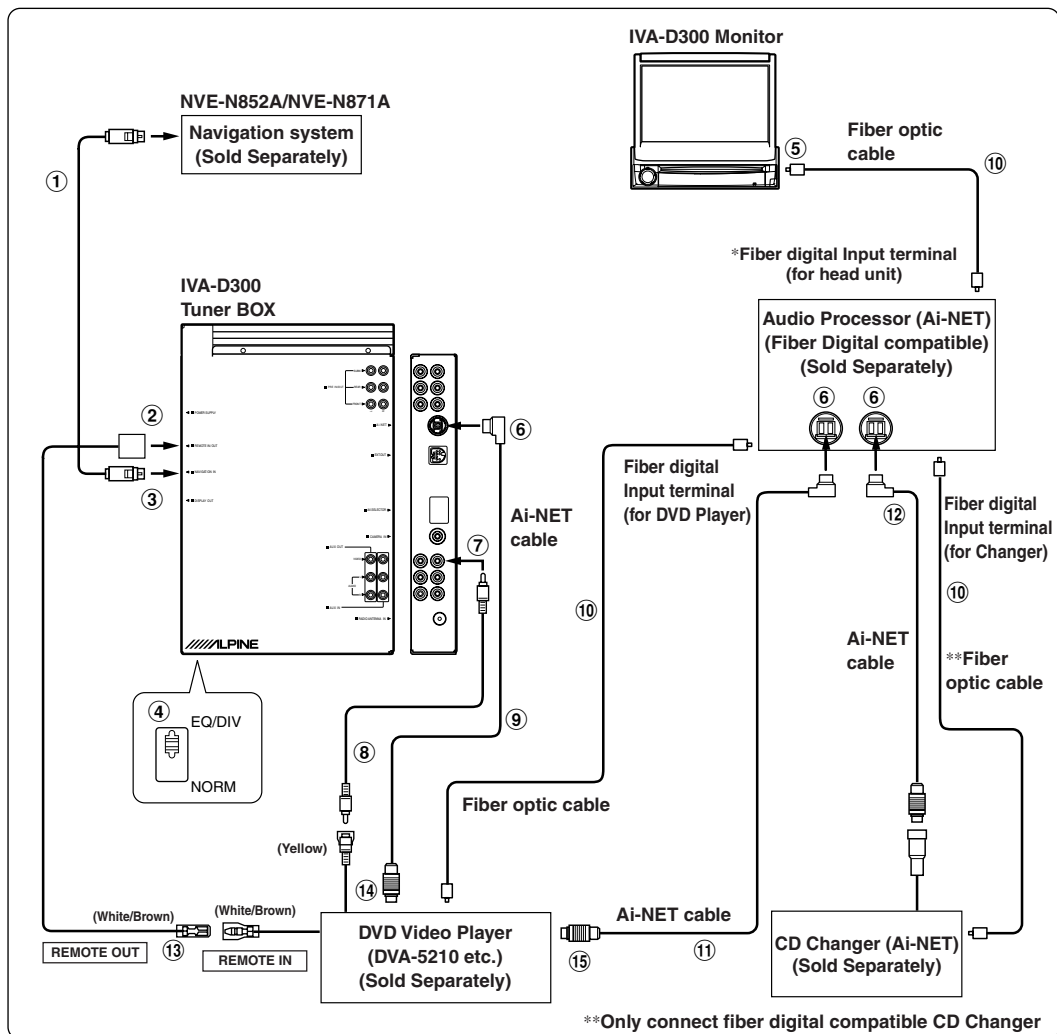

- When the fiber digital compatible product is connected, it is necessary to set the mode of this unit. Refer to "Setting the Digital Output" (page 30) and set to ON. Then refer to "Optical Digital Input Selection for an External Audio Processor" (page 34) and switch the setting.
- \* When connecting with PXA-H510 :
  - Connect the fiber digital input terminal to the DVD.
  - IVA-D300, DVA-5200, DVA-5205 or DVA-5210 cannot be connected simultaneously when fiber digital is in use.
- When the NVA-N751AS is connected for the Navigation System, use the RGB conversion cable KWE-503N (Sold separately).

Please observe the following when using Fiber Optic Cable.

- Do not coil the Fiber Optic Cable smaller than a 30 mm radius.
- Do not place anything on top of the Fiber Optic Cable.

- ① **RGB Cable (Included with NVE-N852, not included with NVE-N871A)**
- ② **Remote IN/OUT Terminal**
- ③ **RGB Input Terminal**

Connect this to the RGB output terminal of the Navigation System.
- ④ **System Switch**

When connecting an equalizer or divider using Ai-NET feature, place this switch in the EQ/DIV position. When no device is connected, leave the switch in the NORM position.

  - *Be sure to turn the power off to the unit before changing the switch position.*
- ⑤ **Digital Output Terminal**
- ⑥ **Ai-NET Connector**

Connect this to the output or input connector of other product equipped with Ai-NET.
- ⑦ **AUX Video Input (AUX1) Terminal**

Connect the video output lead of a DVD video player or DVD changer to this terminal.
- ⑧ **RCA Extension Cable (Included with DVD video player)**
- ⑨ **Ai-NET Cable (Included with DVD video player)**
- ⑩ **Fiber optic Cable (Sold Separately)**
- ⑪ **Ai-NET Cable (Included with Audio Processor)**
- ⑫ **Ai-NET Cable (Included with CD Changer)**
- ⑬ **Remote Control Output Lead (White/Brown)**

Connect this lead to the remote control input lead. This lead outputs the controlling signals from the remote control.
- ⑭ **To Ai-NET Connector (Gray)**
- ⑮ **To Ai-NET Connector (Black)**

## When Connecting External Equipment

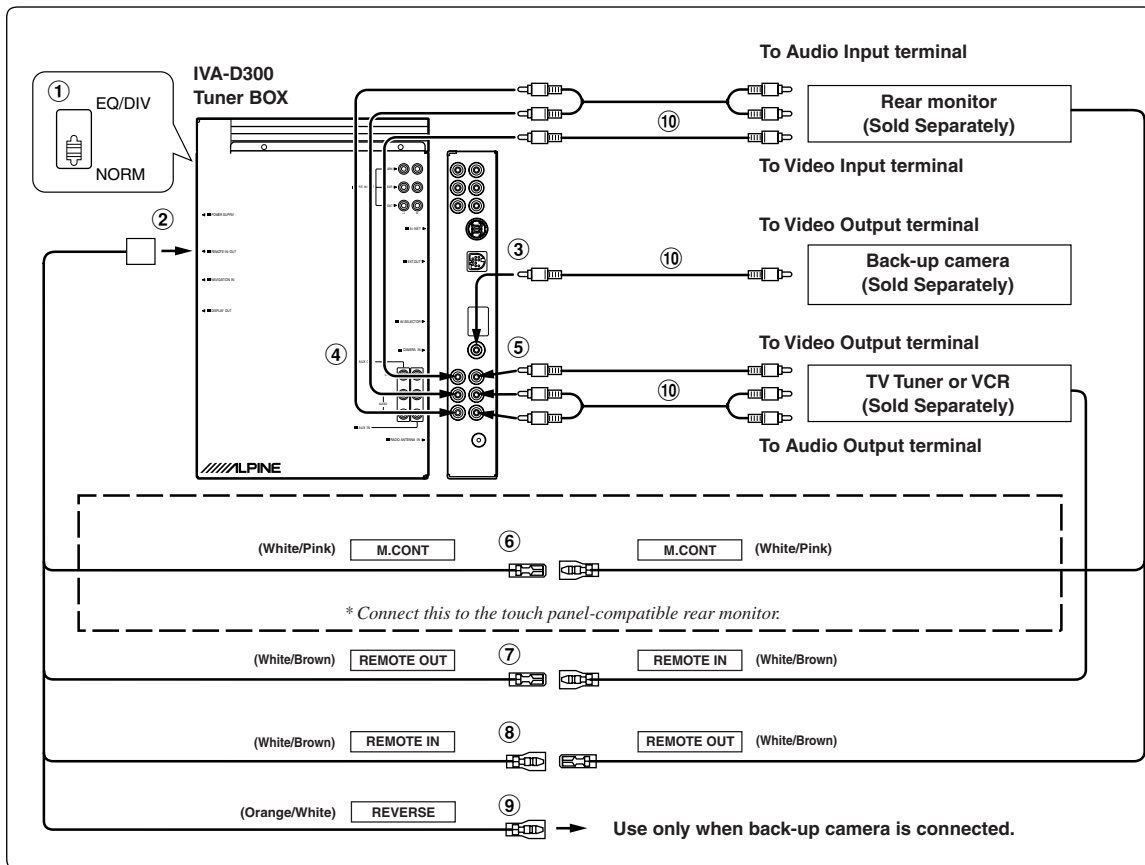

### ① System Switch

When connecting an equalizer or divider using Ai-NET feature, place this switch in the EQ/DIV position. When no device is connected, leave the switch in the NORM position.

- Be sure to turn the power off to the unit before changing the switch position.

### ② Remote IN/OUT Terminal

### ③ CAMERA Input Terminal

Use when connecting a back-up camera.

### ④ AUX Video/Audio Output Terminal

Use when connecting an optional monitor etc.

### ⑤ AUX Video/Audio Input Terminal

### ⑥ Monitor Control Lead (White/Pink)

Connect this to the Monitor Control Lead of the touch panel-compatible rear monitor.

### ⑦ Remote Control Output Lead (White/Brown)

Connect this lead to the remote control input lead. This lead outputs the controlling signals from the remote control.

### ⑧ Remote Control Input Lead (White/Brown)

### ⑨ Connect to the plus side of the car's reverse lamp which lights when the transmission is shifted into reverse (R).

Switches the video picture to the back-up camera. This is linked to putting the car into reverse (R).

### ⑩ RCA Extension Cable (Sold separately)

**Connect an expansion box (VPE-S431), DVD Player, DVD Changer or the Touch Panel-compatible Monitor.**

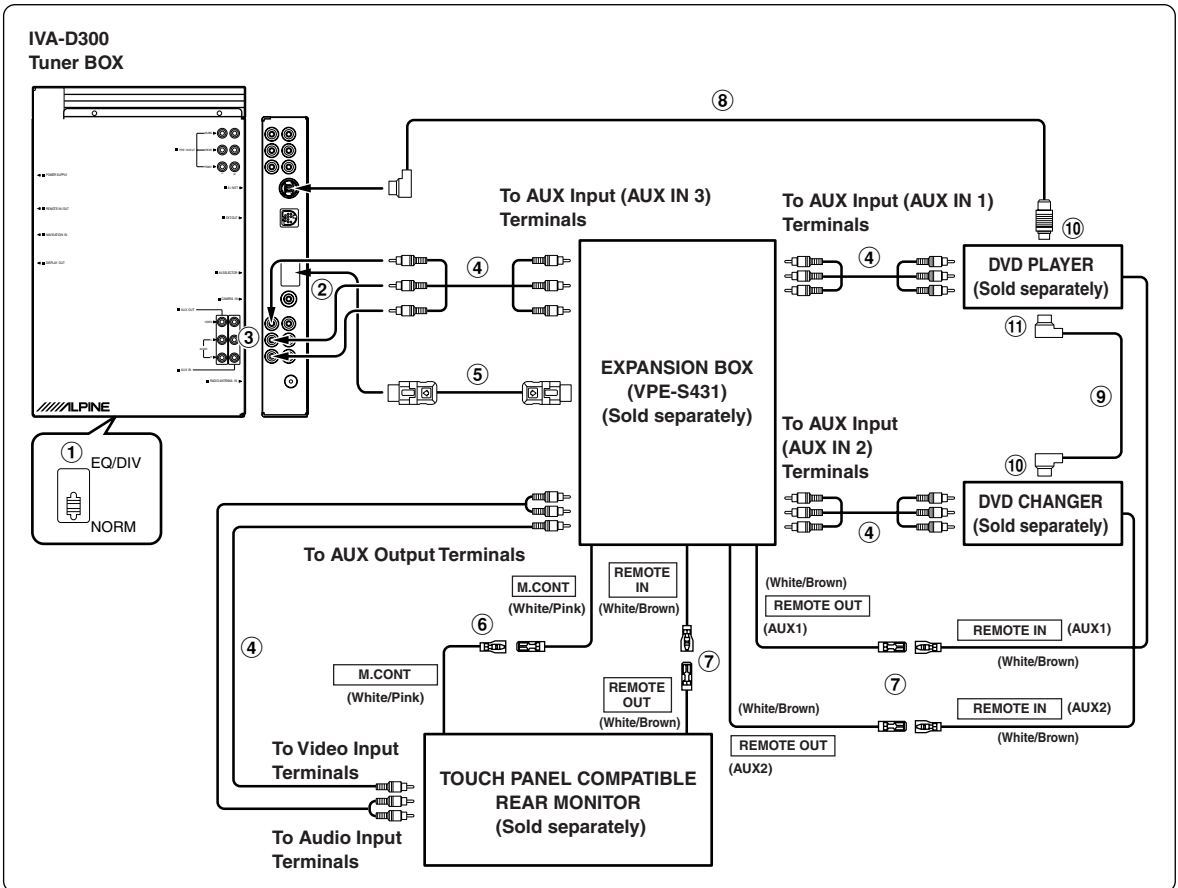

- If the expansion box (VPE-S431) is connected to either a DVD video player or DVD changer, connect this to AUX IN 1. If this is connected to AUX IN 2, remote control operation will not be possible. If both are to be connected, connect the DVD video player to AUX IN 1, and the DVD changer to AUX IN 2.

**① System Switch**

When connecting an equalizer or divider using Ai-NET feature, place this switch in the EQ/DIV position. When no device is connected, leave the switch in the NORM position.

- Be sure to turn the power off to the unit before changing the switch position.

**② To AV Selector Terminal**

**③ AUX Video/Audio Output Terminal**

**④ RCA Extension Cable (Sold separately)**

**⑤ AV Selector Cable (Included with VPE-S431)**

**⑥ Monitor Control Lead (White/Pink)**

Connect this to the Monitor Control Lead of the touch panel-compatible rear monitor.

**⑦ Remote Control Output Lead (White/Brown)**

Connect this lead to the remote control input lead. This lead outputs the controlling signals from the remote control.

**⑧ Ai-NET Cable (Included with DVD video player)**

**⑨ Ai-NET Cable (Included with DVD changer)**

**⑩ To Ai-NET Connector (Black)**

**⑪ To Ai-NET Connector (Gray)**

# LIMITED WARRANTY

ALPINE ELECTRONICS OF AMERICA, INC. AND ALPINE OF CANADA INC. ("Alpine"), are dedicated to quality craftsmanship and are pleased to offer this Warranty. We suggest that you read it thoroughly. Should you have any questions, please contact your Dealer or Alpine at one of the telephone numbers listed below.

## ●PRODUCTS COVERED:

This Warranty covers Car Audio/Visual Products and Related Accessories ("the product"). Products purchased in the Canada are covered only in the Canada. Products purchased in the U.S.A. are covered only in the U.S.A.

## ●LENGTH OF WARRANTY:

This Warranty is in effect for one year from the date of the first consumer purchase.

## ●LIFETIME TAPE HEAD WARRANTY:

All Alpine Car Audio analog tape heads excluding Video tape heads are warranted for life against manufacturing defects causing failure.

## ●WHO IS COVERED:

This Warranty only covers the original purchaser of the product, who must reside in the United States, Puerto Rico or Canada.

## ●WHAT IS COVERED:

This Warranty covers defects in materials or workmanship (parts and labor) in the product.

## ●WHAT IS NOT COVERED:

This Warranty does not cover the following:

- ① Damage occurring during shipment of the product to Alpine for repair (claims must be presented to the carrier).
- ② Damage caused by accident, abuse, negligence, misuse, improper connections, improper operation or failure to follow instructions contained in the Owner's manual.
- ③ Damage caused by act of God, including without limitation, earthquake, fire, flood, storms or other acts of nature.
- ④ Any cost or expense related to the removal or reinstallation of the product.
- ⑤ Service performed by an unauthorized person, company or association.
- ⑥ Any product which has the serial number defaced, altered or removed.
- ⑦ Any product which has been adjusted, altered or modified without Alpine's consent.
- ⑧ Any product not distributed by Alpine within the United States, Puerto Rico or Canada.
- ⑨ Any product not purchased from an Authorized Alpine Dealer.
- ⑩ Any product that has been determined to contain an excessive amount of dust or dirt and any product that contains other contaminants including liquid or foreign objects.

## ●HOW TO OBTAIN WARRANTY SERVICE:

- ① You are responsible for delivery of the product to an Authorized Alpine Service Center or Alpine for repair and for payment of any initial shipping charges. Alpine will, at its option, repair or replace the product with a new or reconditioned product without charge. If the repairs are covered by the warranty, and if the product was shipped to an Authorized Alpine Service Center or Alpine, Alpine will pay the return shipping charges.

- ② You should provide a detailed description of the problem(s) for which service is required.
- ③ You must supply proof of your purchase of the product.
- ④ You must package the product securely to avoid damage during shipment.

## ●HOW WE LIMIT IMPLIED WARRANTIES:

ANY IMPLIED WARRANTIES INCLUDING FITNESS FOR USE AND MERCHANTABILITY ARE LIMITED IN DURATION TO THE PERIOD OF THE EXPRESS WARRANTY SET FORTH ABOVE AND NO PERSON IS AUTHORIZED TO ASSUME FOR ALPINE ANY OTHER LIABILITY IN CONNECTION WITH THE SALE OF THE PRODUCT.

## ●HOW WE EXCLUDE CERTAIN DAMAGES:

ALPINE EXPRESSLY DISCLAIMS LIABILITY FOR INCIDENTAL AND CONSEQUENTIAL DAMAGES CAUSED BY THE PRODUCT. THE TERM "INCIDENTAL DAMAGES" REFERS TO EXPENSES OF TRANSPORTING THE PRODUCT TO THE ALPINE SERVICE CENTER, LOSS OF THE ORIGINAL PURCHASER'S TIME, LOSS OF THE USE OF THE PRODUCT, BUS FARES, CAR RENTALS OR OTHERS COSTS RELATING TO THE CARE AND CUSTODY OF THE PRODUCT. THE TERM "CONSEQUENTIAL DAMAGES" REFERS TO THE COST OF REPAIRING OR REPLACING OTHER PROPERTY WHICH IS DAMAGED WHEN THIS PRODUCT DOES NOT WORK PROPERLY. THE REMEDIES PROVIDED UNDER THIS WARRANTY ARE EXCLUSIVE AND IN LIEU OF ALL OTHERS.

## ●HOW STATE/PROVINCIAL LAW RELATES TO THE WARRANTY:

This Warranty gives you specific legal rights, and you may also have other rights which vary from state to state and province to province. In addition, some states/provinces do not allow limitations on how long an implied warranty lasts, and some do not allow the exclusion or limitation of incidental or consequential damages. Accordingly, limitations as to these matters contained herein may not apply to you.

## ●IN CANADA ONLY:

This Warranty is not valid unless your Alpine car audio product has been installed in your vehicle by an Authorized Installation Center, and this warranty stamped upon installation by the installation center.

## ●HOW TO CONTACT CUSTOMER SERVICE:

Should the product require service, please call the following number for your nearest Authorized Alpine Service Center.

U.S.A.	1-800-ALPINE-1 (1-800-257-4631)
CANADA	1-800-ALPINE-1 (1-800-257-4631)