

***Strata***<sup>®</sup> *DK8 & DK16*  
**Digital Key Telephone Systems**

**DK8 & DK16**  
**INSTALLATION AND MAINTENANCE MANUAL**

**TOSHIBA AMERICA INFORMATION SYSTEMS, INC.**

# ***Strata***<sup>®</sup> *DK8 & DK16*

## DIGITAL KEY TELEPHONE SYSTEM **GENERAL DESCRIPTION**

FIGURE LIST (CONTINUED)

FIGURE	SUBJECT	PAGE
19	DOOR PHONE/LOCK CONTROL UNIT (DDCB).....	14
20	60-BUTTON DIRECT STATION SELECTION CONSOLE .....	15
21	20-BUTTON DIGITAL TELEPHONE WITH ADD-ON MODULE.....	15

TABLE LIST

TABLE	SUBJECT	PAGE
A	DK8 & DK16 GENERAL REQUIREMENTS .....	28
B	DK8 & DK16 STATION LOOP REQUIREMENTS .....	28
C	NETWORK REQUIREMENTS .....	29
D	SYSTEM TONES .....	30
E	DK8 KEY SERVICE UNIT COMPONENTS .....	31
F	DK16 BASE KEY SERVICE UNIT COMPONENTS .....	32
G	DK8 & DK16 TYPICAL RESERVE POWER DURATION ESTIMATES.....	33
H	DK16 EXPANSION KEY SERVICE UNIT COMPONENTS.....	34
I	DK16 PIU/PIOUS INTERFACE OPTIONS .....	34
J	DK8 & DK16 FEATURE CAPACITIES.....	35
K	DK8 PERIPHERAL CAPACITY .....	35
L	DK16 PERIPHERAL CAPACITY .....	36
M	DATA INTERFACE SPECIFICATIONS.....	37
N	DK8 & DK16 SYSTEM FEATURES .....	38
O	DK8 & DK16 STATION FEATURES .....	39

## GENERAL

The STRATA DK8 and STRATA DK16 are private telephone systems tailor-made for small business applications. Each employs state-of-the-art technology to provide its users with an efficient, easy-to-use, feature-rich telephone system.

The systems easily connect to outside public telephone lines (central office lines), and all of the telephones (stations) tied to each system can have direct access to each other as well as to the public network.

Designed with the knowledge that user needs typically evolve, the STRATA DK8 and DK16 are modular. Customers are not tied to one configuration; they can start at a standard configuration and then add to their system as their needs grow and change.

Furthermore, many of the telephones and peripherals supported by STRATA DK8 and DK16 are also compatible with other STRATA systems. This compatibility saves customers money when they migrate from the smaller STRATA DK3 system to a STRATA DK16, or when they migrate from the STRATA DK8 and DK16 to a larger STRATA DK system.

Utilizing specially designed digital or electronic telephones, solid-state electronics within the key service unit translate signals from the station push-button dial pad into either Dual-tone Multi-frequency (DTMF) or rotary-dial signals, as required by the central office. All telephones come equipped with voice announce speakers; speakerphones and liquid crystal display telephones are also available.

A large number of widely-used and sophisticated features are available to STRATA telephone users. Everyday features such as Call Transfer, Call Forwarding, Call Holding, and Call Pickup are executed with just the push of a button or a brief access code. More sophisticated feature operations are easily accomplished with the aid of optional displays built into telephones.

In addition to telephones, a number of other useful peripherals can be connected to the system, including door phones for visitor screening; a music source for Music-on-hold, a speaker for Background Music and Paging, and a voice mail device—like the Toshiba VP Voice Processing System—for voice mail applications (see Figure 1).

## Technology

The STRATA DK8 and STRATA DK16 utilize the advanced technology noted below:

**ISDN-like Architecture:** Toshiba digital telephones connect to the system with one-pair cabling, which uses a 2B+D ISDN-like digital link that can transmit and receive simultaneous voice and data along with control information.

**Pulse Code Modulation:** Digital switching talk-paths allow all central office (CO) and intercom lines to be accessed simultaneously. Analog-to-digital and digital-to-analog conversion is accomplished by CODECs (coder plus decoder) on station and CO line printed circuit boards (PCBs).

**Stored Program Control:** The system uses a 16-bit microprocessor for stored program control. System operating software is stored on 1 megabyte of read only memory (ROM), and individual configuration and custom programming is stored on 128 kilobytes of random access memory (RAM) for DK16 and 64K of RAM for DK8. A lithium battery with a life span of at least six years will preserve RAM in the case of a power failure.

**Microprocessors:** The main microprocessor of the system is a 16-bit 68000-type that operates at a clock speed of 8 megahertz (MHz). In addition, some printed circuit boards employ 8-bit, TMP90C840-type local microprocessors that run at 10 MHz. This distributed microprocessing architecture is used throughout the system.

STRATA DK8 & DK16  
 GENERAL DESCRIPTION  
 MARCH 1993

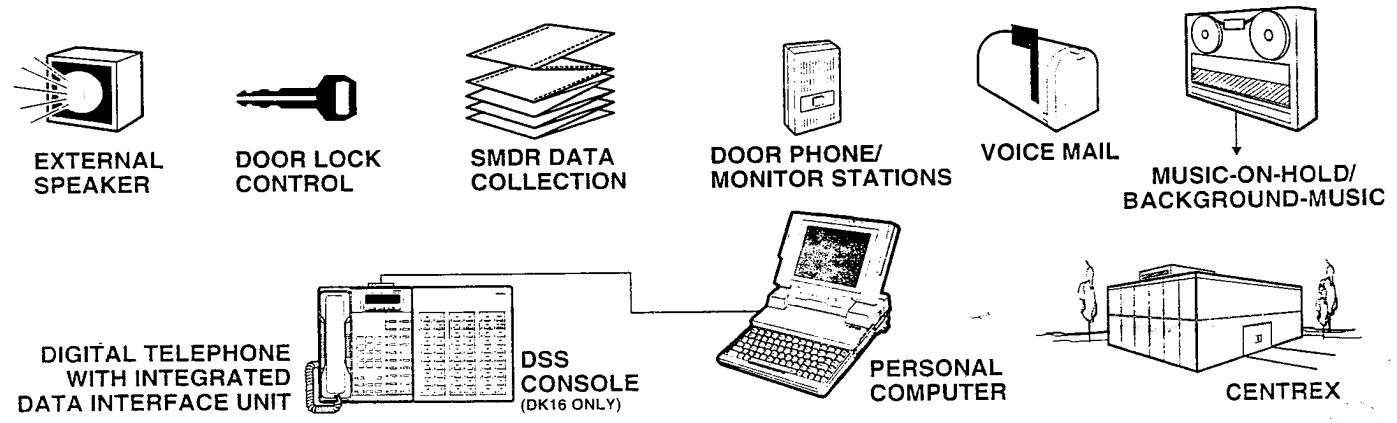
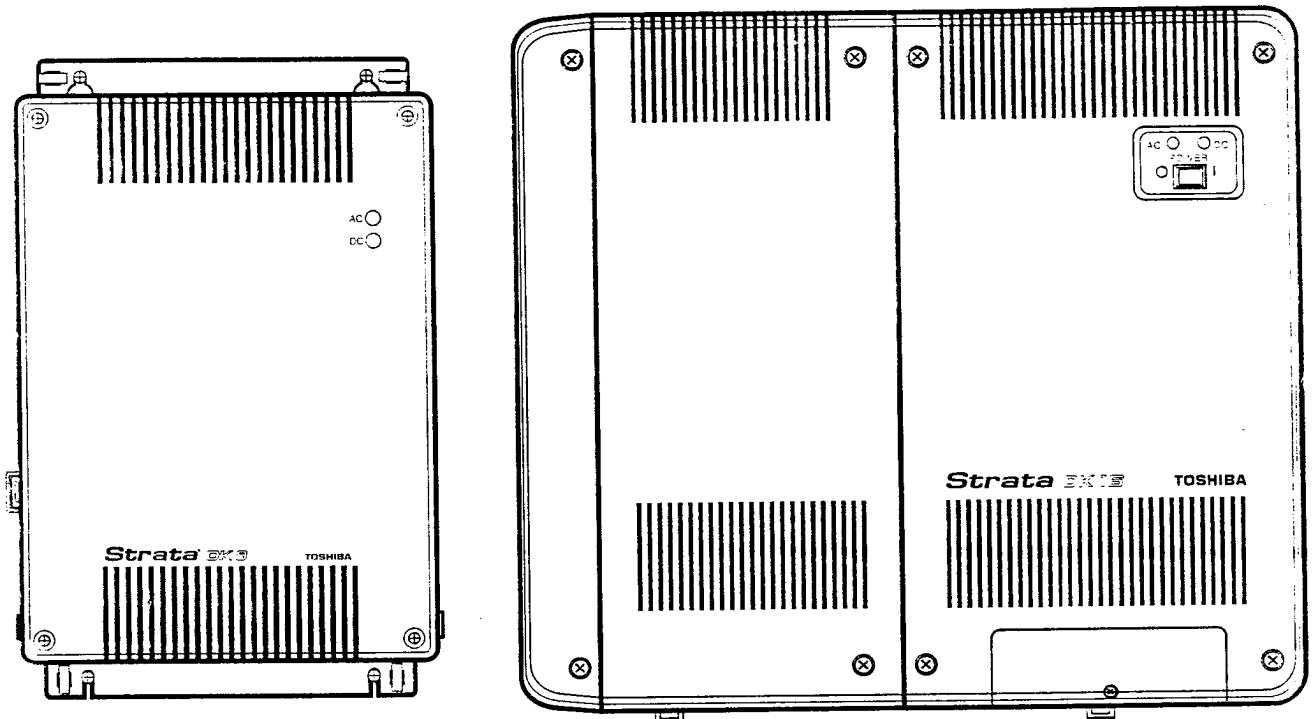
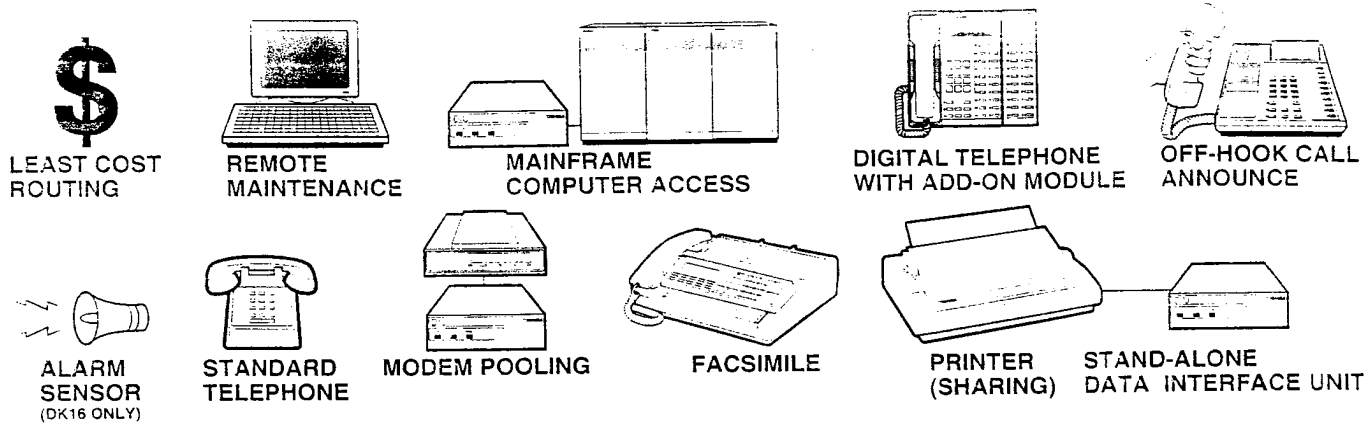


Figure 1  
 STRATA DK8 & DK16 PERIPHERALS

**Custom Electronic Circuitry:** Large scale integration (LSI) technology enables STRATA DK8 and DK16 circuit design to be simple and efficient. Gate arrays using very large scale integration save vast amounts of space by utilizing the latest technology. More circuitry fits onto smaller PCBs for a more compact system. Widespread use of CMOS circuits minimize system power requirements.

### Maintenance and Programming

Maintaining and troubleshooting STRATA DK8 and DK16 is easy because of its modular architecture. Problems are typically localized and don't affect other units. Hardware maintenance and repair procedures describe how to quickly locate, remove, and replace defective modules.

System programming can be performed without taking the system out of service. On-site programming can be executed with any 20-button proprietary LCD (liquid crystal display) telephone, or with an ASCII terminal connected to an optional maintenance port. Off-site programming—which can help cut costs and save time—is available through an optional modem.

## 2 SYSTEM CONFIGURATION

The main building blocks of each system are cabinet-like units called Key Service Units. The STRATA DK8 consists of a single Key Service Unit (Figure 2). The STRATA DK16 is comprised of the Base Key Service Unit (Figure 3) and the Optional Expansion Key Service Unit (Figure 4).

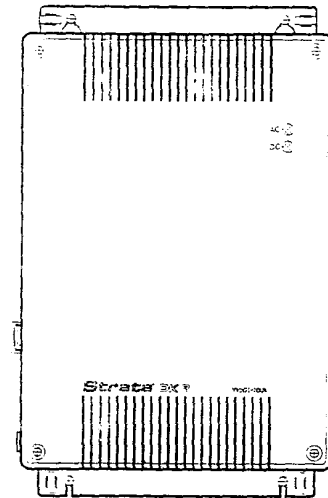


Figure 2  
STRATA DK8 BASE KEY SERVICE UNIT

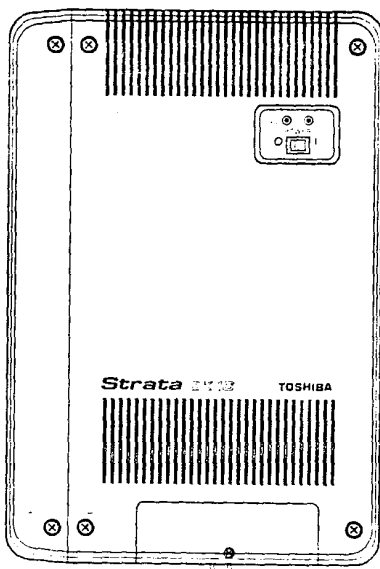


Figure 3  
STRATA DK16 BASE KEY SERVICE UNIT

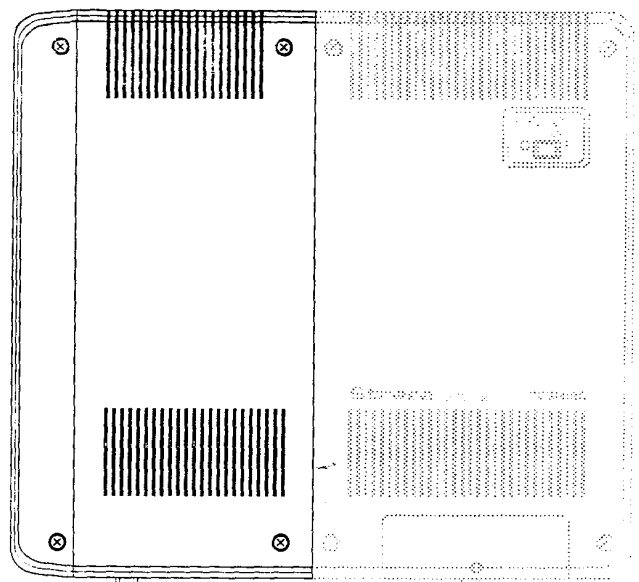


Figure 4  
STRATA DK16 EXPANSION KEY SERVICE UNIT

STRATA DK8 & DK16  
 GENERAL DESCRIPTION  
 MARCH 1993

Every central office (CO) line, station, and peripheral connects to these units.

The STRATA DK8 Key Service Unit comes equipped to interface with up to four Toshiba-proprietary digital telephones and two CO lines. It can optionally be equipped with up to two one-circuit CO line/two-circuit digital telephone printed circuit boards and a two-circuit standard telephone printed circuit board. An SMDR/TTY interface, a Music-on-hold source, a Background Music (BGM) source, a night bell, and an amplifier/speaker for external page may also be added as needed.

At maximum configuration, the DK8 can interface with up to eight digital telephones, four CO lines, and two standard telephone devices. Note that while the DK8 provides up to ten station ports, only eight can be digital telephones, with the last two standard station ports designed for peripheral device or standard telephone interface.

The STRATA DK16 Base Key Service Unit comes equipped to interface with up to eight Toshiba-proprietary digital telephones and four CO lines. It can optionally be equipped with a four-circuit standard telephone printed circuit board, a Music-on-hold source, a BGM source, a night bell, and an amplifier/speaker for external page.

The optional STRATA DK16 Expansion Key Service Unit can be attached to the standard unit to increase system capacities. A system equipped with the optional unit can support up to eight CO lines and 16 Toshiba-proprietary telephones by using up to three additional PCBs. An SMDR/TTY interface may also be added as needed. Note that while the DK16 provides up to 20 station ports, only 16 can be digital telephones, with the last four standard station ports designed for peripheral device or standard telephone interface.

Maximum capacities for STRATA DK8 and DK16 systems are shown in Figures 5 and 6.

	CO LINES	DIGITAL TELEPHONES	STANDARD TELEPHONES
BASIC KEY SERVICE UNIT	2	4	0
EXPANDED KEY SERVICE UNIT	4	8	2

Figure 5  
 STRATA DK8 MAXIMUM CONFIGURATION

	CO LINES	DIGITAL TELEPHONES	ELECTRONIC TELEPHONES	STANDARD TELEPHONES
BASE KEY SERVICE UNIT	4	8	0	4
WITH EXPANSION KEY SERVICE UNIT	8	8	8	4
	8	16	0	4
	8	8	0	12

Figure 6  
 STRATA DK16 MAXIMUM CONFIGURATION

### 3 SYSTEM COMPONENTS

This section describes the components of the STRATA DK8 Key Service Unit and the STRATA DK16 Base and Expansion Key Service Units. The functional block diagrams in Figures 7 and 8 illustrate the organization and connection of these components.

#### STRATA DK8 Key Service Unit

In addition to the +5 volt converter, main processor and operating software for the system, the Key Service Unit contains the circuitry and components (Figure 9 and Table E) as described in the following paragraphs. The weight and dimensions of the unit, which is designed for wall mounting, are as follows:

- Height: 16.4 in (416 mm)
- Width: 10.0 in (254 mm)
- Depth: 3.0 in (76 mm)
- Weight: 5.7 lbs (2.59 kg)

**Digital Telephone Circuits:** The main circuit board has four integrated circuits that can connect to digital telephones, stand-alone data interface units (PDIU-DSs), and a digital door phone/lock control unit (DDCB). Furthermore, each of the digital telephones can support an integrated data interface unit (PDIU-DI) or an add-on module (ADM).

**CO Line Circuits:** Two circuits for loop start central office (CO) lines are built into the main circuit board. Each line can be programmed for Dual-tone Multi-frequency (DTMF) or dial pulse signaling and has a switch to control potential excess volume that could be created by a nearby private branch exchange (PBX) or CO. Built-in gas tubes help protect each circuit from lightning.

**Power Supply:** The power supply generates +24VDC for the entire system, even in its expanded configuration.

**Reserve Power:** One or two optional Reserve Power Battery and Chargers (HPFBs) can be connected to the STRATA DK8 power supply

to maintain normal operation during a power failure (See Table G for reserve power time.)

**Power Failure Interface:** The Key Service Unit provides an interface for a dedicated backup standard telephone during a power failure. If the system power fails, the backup telephone will automatically connect to the CO1 line. This feature is independent of the HPFB.

**Music-on-Hold Interface:** Customers can connect their own Music-on-hold source to this interface. The source can also feed external page speakers and telephone speakers with Background Music.

**Paging Interface:** This 600-ohm interface can support a Toshiba external speaker (HESB) or a customer-supplied amplifier and speaker for Paging, night ringing, and Background Music applications.

**Flexible Relay Contact:** A relay contact can be programmed to either mute Background Music during a page announcement over external speakers, to operate a device—such as an answering machine or ringing bell—during the Night Mode, or to provide on-off control for a Music-on-hold source.

**Conference Interface (QCNU):** The standard, factory-installed QCNU provides two conference circuits which provide for simultaneous conversation between stations and/or CO lines connected to the DK8. The first conference circuit allows simultaneous conversation between four parties; the second circuit supports three parties.

#### STRATA DK8 Optional PCBs

**CO Line/Digital Telephone Interface Unit (QCDU):** The QCDU provides one CO line circuit and two digital telephone circuits. The CO line circuit offers all of the features that the Key Service Unit CO line circuits provide, and the digital telephone circuits can support every peripheral (except DDCB) that the Key Service Unit digital circuits can support. Up to two QCDU units may be installed.



STRATA DK8 & DK16  
 GENERAL DESCRIPTION  
 MARCH 1993

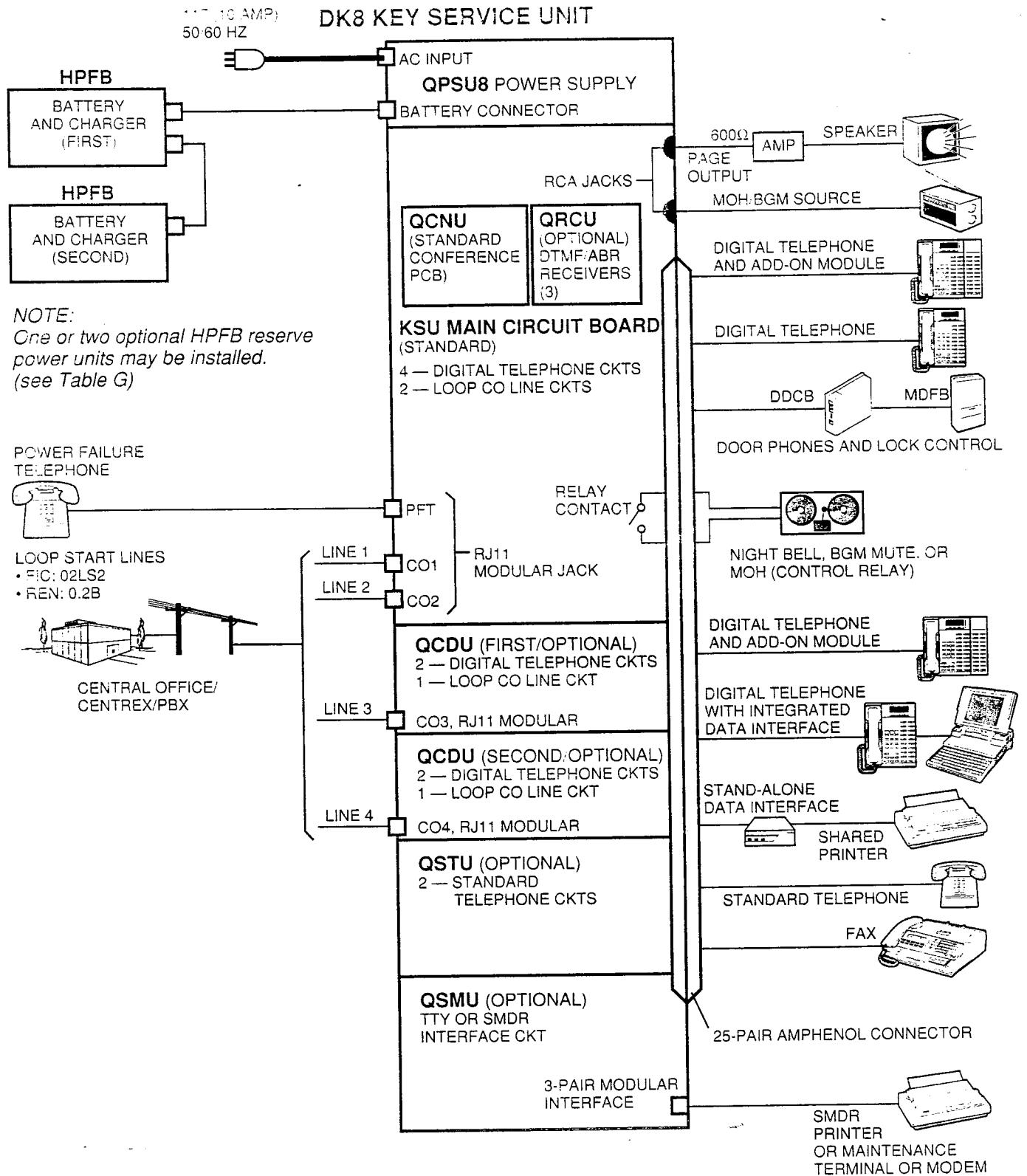


Figure 7  
 STRATA DK8 FUNCTIONAL BLOCK DIAGRAM

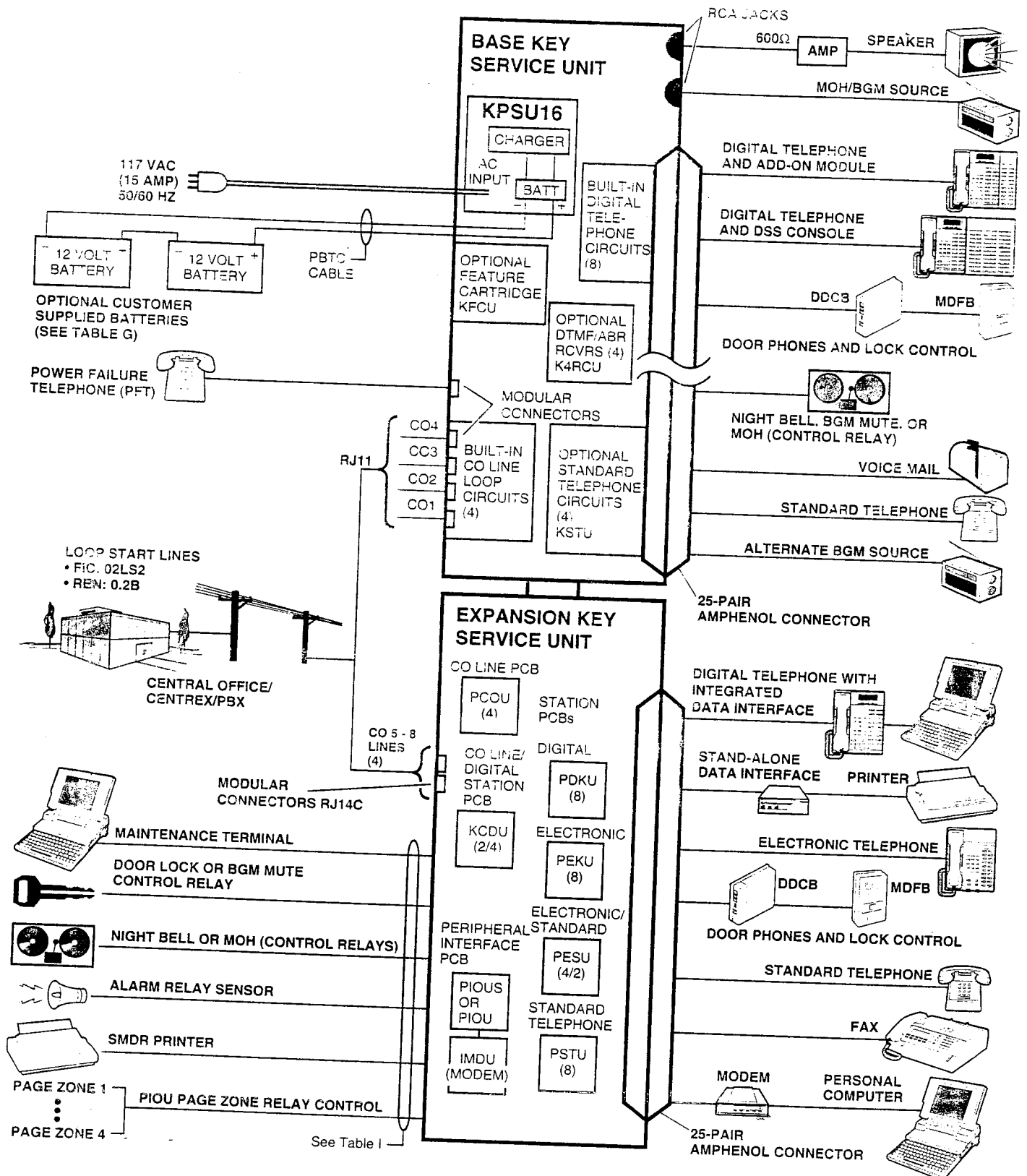


Figure 8  
 STRATA DK16 FUNCTIONAL BLOCK DIAGRAM

STRATA DK8 & DK16  
 GENERAL DESCRIPTION  
 MARCH 1993

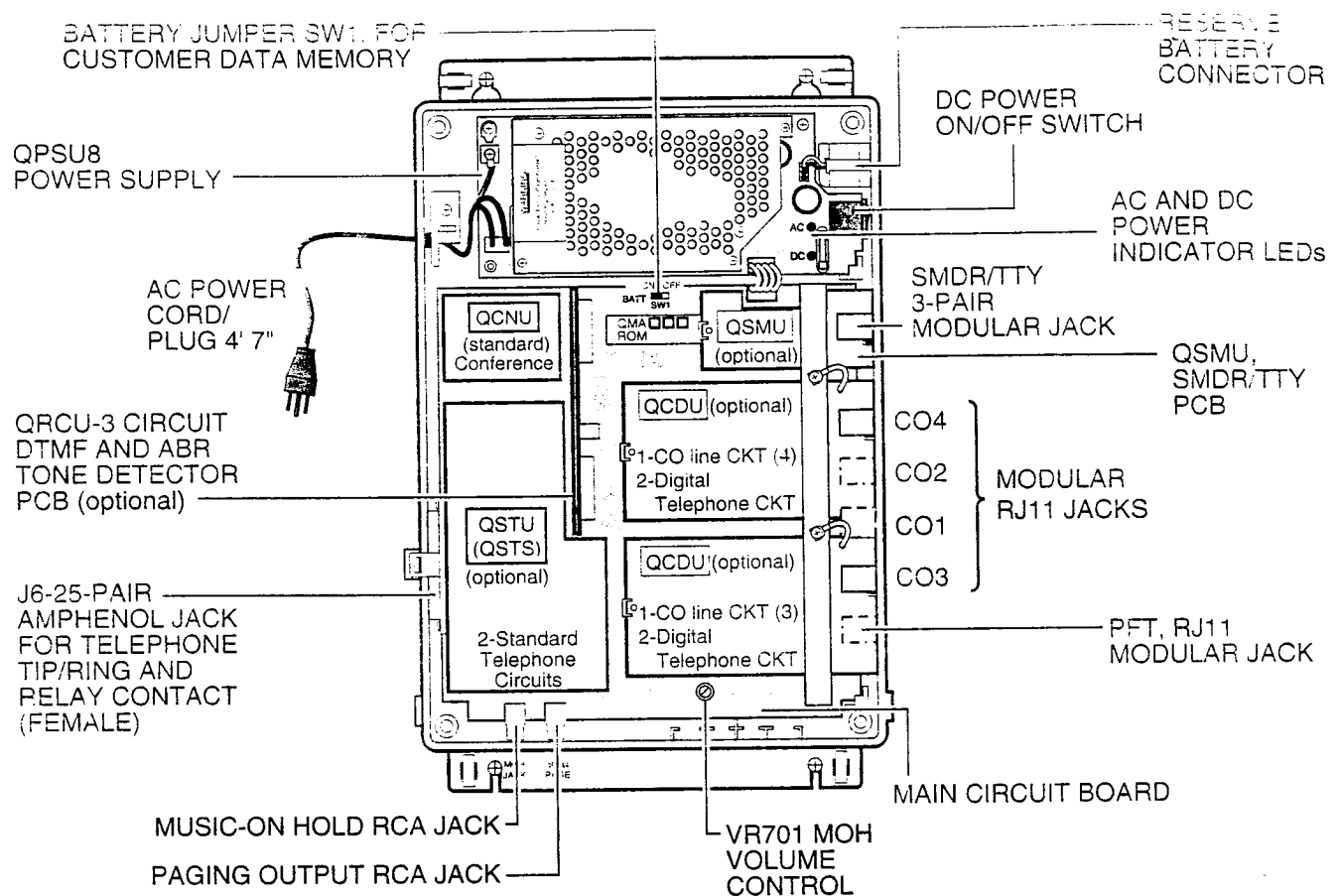


Figure 9  
 STRATA DK8 KEY SERVICE UNIT INTERIOR (CONNECTORS AND INTERFACES)

**Standard Telephone Interface Unit (QSTU):**

The optional QSTU provides two circuits that can interface with 500- and 2500-type standard telephones, as well as the other single-line devices listed below. These devices may require that the optional QRCU be installed in the Base Key Service Unit to interpret the Dual-tone Multi-frequency (DTMF) signals they may transmit.

- Fax Machines
- Modem
- Dictation Equipment
- Off-premises Stations
- Voice Mail Devices
- Auto Attendant Devices

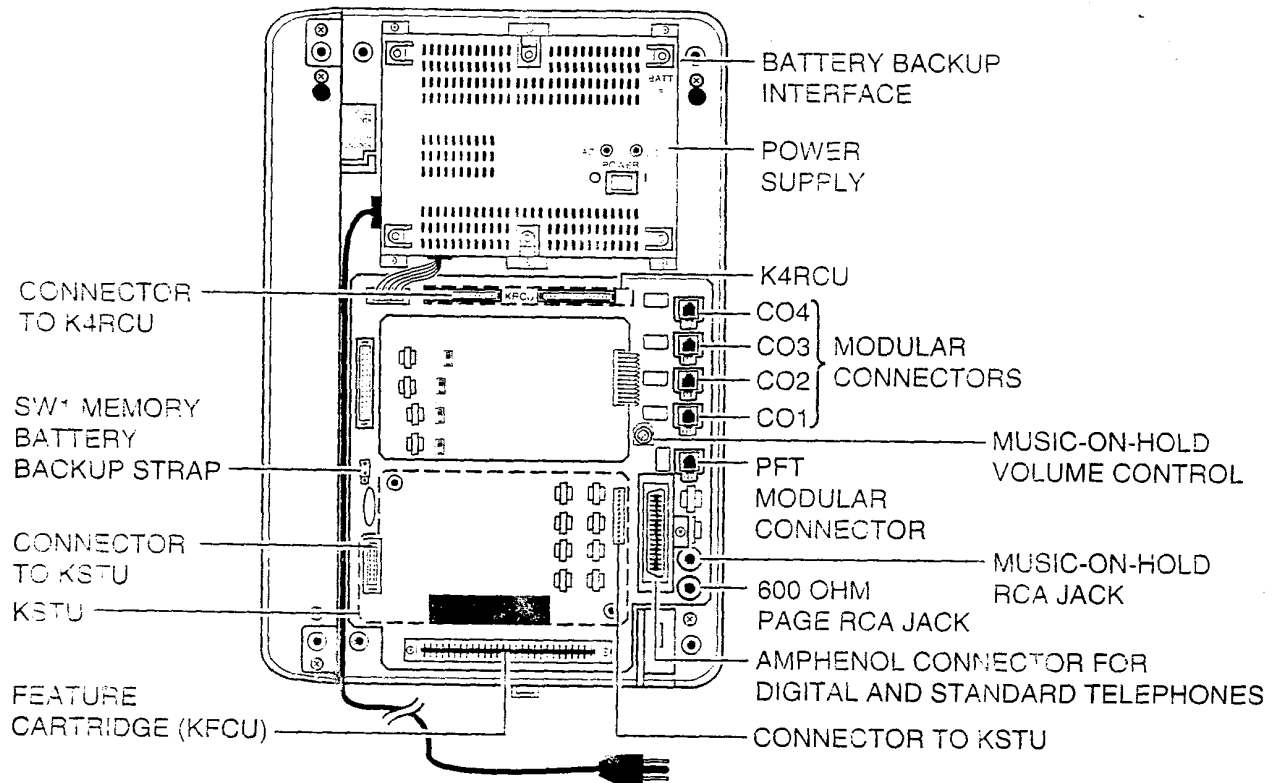
**DTMF/ABR Tone Detection Receiver (QRCU):**

Station users in systems that have the optional QRCU installed can access Automatic Busy

Redial (ABR); and, communicate with devices, such as standard telephones or voice mail machines, that require Dual-tone Multi-frequency (DTMF) signaling. This unit is also required for Direct Inward System Access (DISA) operation. Three shared receiver circuits are included.

**SMDR/TTY Interface Unit (QSMU):**

The optional QSMU provides an interface for either SMDR output or TTY maintenance port. QSMU operation is software selectable (TTY or SMDR). A customer-supplied printer or Call Accounting device can be connected to the QSMU for SMDR; or a terminal (local maintenance) or modem (Remote Maintenance) can be connected to the QSMU for system programming. Only one option (SMDR or TTY) can function at a time.



**Figure 10**  
 STRATA DK16 BASE KEY SERVICE UNIT INTERIOR (CONNECTORS AND INTERFACES)

**STRATA DK16 Base Key Service Unit**

In addition to the main processor and operating software for the system, the Base Key Service Unit contains the circuitry and components (Figure 10 and Table F) described as follows. The weight and dimensions of the unit, which is designed for wall mounting, are as follows:

- Height: 18.0 in (457 mm)
- Width: 12.2 in (310 mm)
- Depth: 3.4 in (86 mm)
- Weight: 8.4 lbs (3.8 kg)

**Digital Telephone Circuits:** The main circuit board has eight integrated circuits that can connect to digital telephones, stand-alone data interface units (PDIU-DSs), one digital door phone/lock control unit (DDCB), and a digital direct station selection console (DDSS). Furthermore, each of the digital telephones

can support an integrated data interface unit (PDIU-DI) or an add-on module (ADM).

**CO Line Circuits:** Four circuits for loop start central office (CO) lines are built into the main circuit board. Each line can be programmed for Dual-tone Multi-frequency (DTMF) or dial pulse signaling and has a switch to control potential excess volume that could be created by a nearby private branch exchange (PBX) or CO. Built-in gas tubes help protect each circuit from lightning.

**Power Supply:** The power supply generates  $\pm 5\text{VDC}$  and  $-24\text{VDC}$  for the entire system, even in its expanded configuration. Two customer-supplied 12-volt batteries can be connected to the power supply to maintain normal operation during a power failure. The power supply provides a built-in charger for the batteries (Table G).

STRATA DK3 & DK16  
GENERAL DESCRIPTION  
MARCH 1993

**Power Failure Interface:** The Base Key Service Unit provides an interface for a dedicated backup standard telephone during a power failure. If the system power fails, the backup telephone will automatically connect to the CO1 line. This feature is independent of Battery Backup.

**Music-on-Hold Interface:** Customers can connect their own Music-on-hold source to this interface. The source can also feed external page speakers and telephone speakers with Background Music.

**Paging Interface:** This 600-ohm interface can support a Toshiba external speaker (HESB) or a customer-supplied amplifier and speaker for Paging and Background Music applications.

**Flexible Relay Contacts:** A pair of relay contacts can be programmed to either mute Background Music during a page announcement over external speakers, to operate a device—such as an answering machine or ringing bell—during the Night Mode, or to provide on-off control for a Music-on-hold source.

**Standard Telephone Interface Unit (KSTU):** The optional KSTU provides four circuits that can interface with 500- and 2500-type standard telephones, as well as the other single-line devices listed below. These devices may require that the optional K4RCU be installed in the Base Key Service Unit to interpret the Dual-tone Multi-frequency (DTMF) signals they may transmit.

- Fax Machines
- Modem
- Dictation Equipment
- Alternate Background Music source
- Off-premises Stations
- Voice Mail Devices
- Auto Attendant Devices

**DTMF/ABR Tone Detection Receiver (K4RCU):** Station users in systems that have the optional K4RCU installed can access Automatic Busy Redial (ABR); and, communicate with devices, such as standard telephones or voice mail machines, that require Dual-tone Multi-frequency (DTMF) signaling. This unit is also

required for Direct Inward System Access (DISA) operation. Four shared receivers are provided.

**Feature Cartridge (KFCU):** The optional plug-in feature cartridge will allow for the integration of future feature upgrades.

### STRATA DK16 Expansion Key Service Unit

The optional Expansion Key Service Unit, which attaches easily to the side of the Base Unit, offers four universal slots (Figure 11), three of which can host any of the printed circuit boards (PCBs) described in the following paragraphs (Table H). The weight and dimensions of the unit are as follows:

- Height: 18.0 in (457 mm)
- Width: 7.8 in (198 mm)
- Depth: 3.4 in (86 mm)
- Weight: 1 lb (.45 kg) when empty
- Weight: 5.3 lbs (2.4 kg) when full

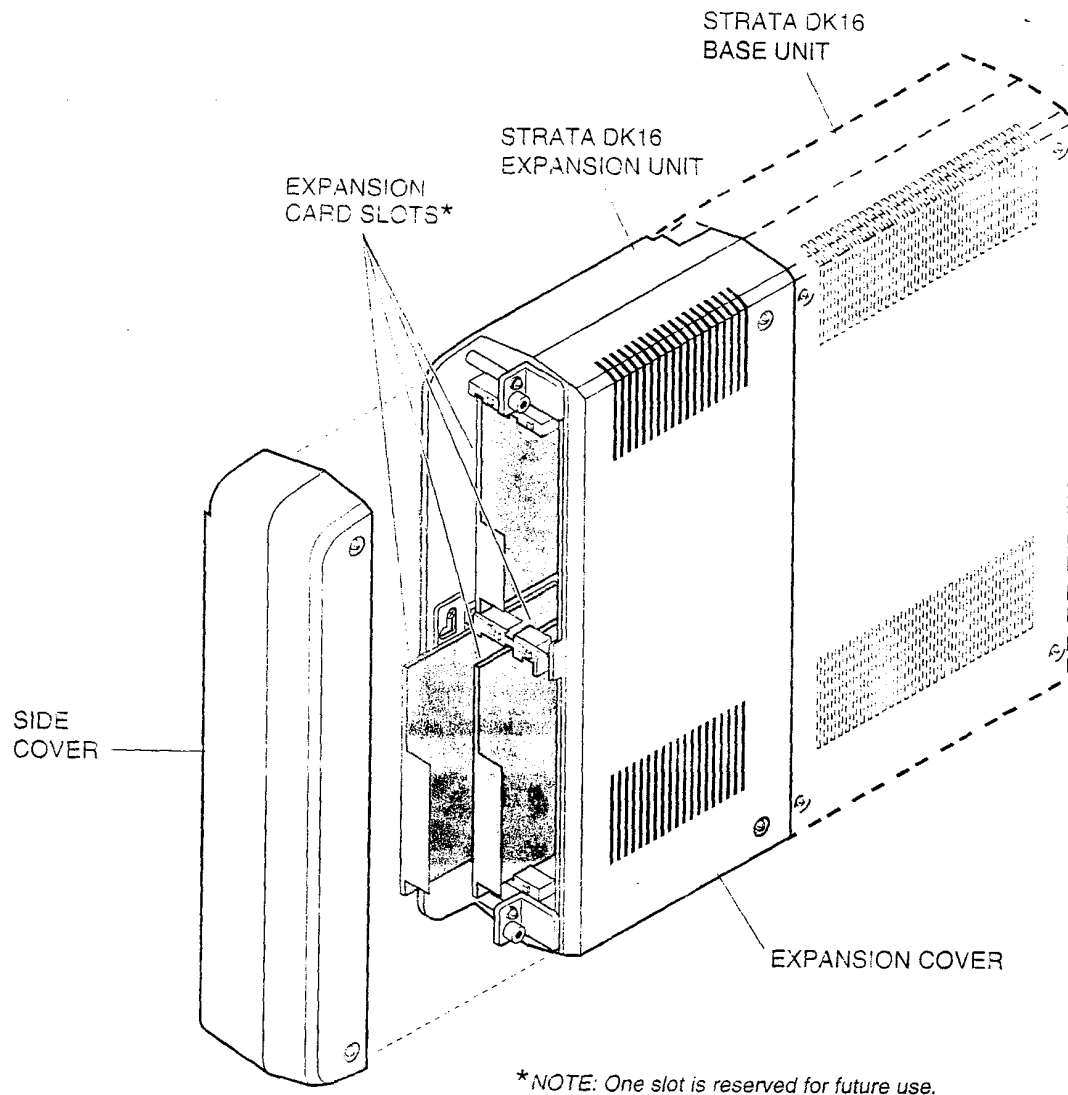
**NOTE:**

*No more than three Expansion Key Service Unit slots can be occupied at one time. The fourth slot is reserved for future use.*

**CO Line Interface Unit (PCOU):** The PCOU has four loop start CO line circuits that have the same characteristics as the CO circuits in the Base Key Service Unit.

**Digital Telephone Interface Unit (PDKU):** The PDKU has eight digital telephone circuits that can support the same peripherals as the digital circuits in the Base Key Service Unit.

**Option Interface Unit (PIOU):** The PIOU provides interfaces for such useful features as external zone paging, Station Message Detail Recording (SMDR), and a remote maintenance modem subassembly (IMDU). Additionally, it has relay contacts for the control of a customer-provided door lock, Music-on-hold source, and more (Table I). The PIOU three-watt or 600  $\Omega$  paging output is not used since paging is supported by the Base Key Service Unit paging interface.



\*NOTE: One slot is reserved for future use.

Figure 11  
STRATA DK16 EXPANSION KEY SERVICE UNIT INTERIOR

**Simplified Option Interface Unit (PIOUS):** With the exception of the Zone Paging interface, the PIOUS has everything that the PIOU has, including the SMDR and IMDU interfaces (Table I).

**Remote Maintenance Modem Subassembly (IMDU):** The IMDU is an optional modem that joins to a PIOU or PIOUS to provide the system with a link to off-site programming and maintenance equipment, such as a personal computer or ASCII terminal. It has an internal maintenance channel and does not require a dedicated CO line or station port. Data trans-

mission speed can be set at 300 or 1200 BPS full duplex.

**Standard Telephone Interface Unit (PSTU):** The PSTU has eight standard telephone circuits which can interface with the same devices as the optional KSTU in the Base Key Service Unit. A K4RCU installed in the Base Key Service Unit interprets DTMF tones transmitted by devices connected to the PSTU.

**Electronic Telephone Interface Unit (PEKU):** The PEKU provides eight electronic telephone circuits that can interface with electronic tele-

STRATA DK8 & DK16  
GENERAL DESCRIPTION  
MARC - 1993

phones, an Alternate Background Music (BGM) source, a direct station selection console (HDSS), an external amplifier for Direct Inward System Access (DISA) or two-CO line Conferencing.

**Standard/Electronic Telephone Interface Unit (PESU):** The PESU PCB offers two standard and four electronic telephone circuits. Its standard circuits support the same devices as the KSTU and PSTU, and its electronic circuits interface with the same peripherals as the PEKU, except for the HDSS console. Standard DTMF telephone circuit operation requires a K4RCU in the Base Key Service Unit.

**Off-hook Call Announce Upgrade Unit (EOCU):** Electronic telephones connected to PEKU and PESU PCBs can receive Off-hook Call Announce—intercom calls over their speaker while they are on another call—if the PCBs are equipped with an EOCU. Digital telephones also support this function but do not require an EOCU type PCB in the KSU.

**CO Line/Digital Telephone Interface Unit (KCDU):** The KCDU provides two CO line circuits and four digital telephone circuits. The CO line circuits offer all of the features that the Base Key Service Unit and the PCOU line circuits provide. The digital telephone circuits

can support every peripheral, except for the DDSS console, that the PDKU and a Base Key Service Unit digital circuit can support.

### Toshiba Peripherals

Toshiba offers a number of peripherals that can be connected to the STRATA DK8 and DK16 systems. Tables K and L contain the capacity and interface of each peripheral, including customer-supplied peripherals.

**Digital Telephones:** The STRATA 2000-series digital telephones possess the most up-to-date features with an attractive design, available in charcoal gray or ash white. The STRATA DK8 can support up to eight of the 2000-series digital telephones; the STRATA DK16 can support as many as 16. There are four models in this series—the DKT2010-H (Figure 12), DKT2010-SD (Figure 13), DKT2020-S (Figure 14), and the DKT2020-SD (Figure 15)—each of which provides some or all of the features described below.

- **Liquid Crystal Display (LCD)**—Available with the DKT2010-SD and the DKT2020-SD, LCDs display a variety of calling and messaging information. LCD telephone users can access the following features and more:
  - Feature Prompting Soft Keys
  - Alphanumeric Messaging
  - Busy Lamp Field (BLF) Indication
  - Central Office (CO) Line Identification

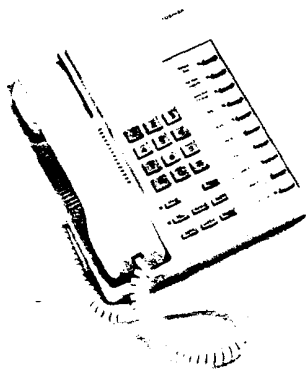


Figure 12  
10-BUTTON DIGITAL TELEPHONE WITH  
HANDSFREE ANSWERBACK (DKT2010-H)



Figure 13  
10-BUTTON DIGITAL SPEAKERPHONE WITH  
LIQUID CRYSTAL DISPLAY (DKT2010-SD)



Figure 14  
20-BUTTON DIGITAL SPEAKERPHONE  
(DKT2020-5)

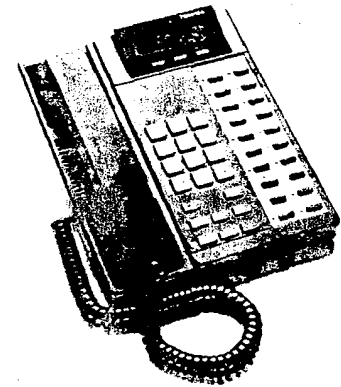


Figure 15  
20-BUTTON DIGITAL SPEAKERPHONE WITH  
LIQUID CRYSTAL DISPLAY (DKT2020-SD)

- Timed Reminders with Messaging
- Intercom User Name/Number Display
- Called Number Display
- Call Duration Display
- Date/Time of Day Display
- **Speakerphone**—DKT2010-SD, DKT2020-S, and DKT2020-SD users can each receive and make outside calls without lifting the handset.
- **Handsfree Answerback**—DKT2010-H users can answer intercom calls from the telephone set speaker without lifting the handset.
- **Flexible Buttons**—Each model has flexible buttons which can be assigned as feature buttons, eliminating the need to dial access codes. The DKT2010-H and the DKT2010-SD both have 10 flexible buttons, and the DKT2020-S and DKT2020-SD have 20 flexible buttons.
- **Fixed Buttons**—Fixed buttons, which are permanently assigned to all of the models, provide access to frequently-used features, such as Hold and Redial.

**Digital Telephone Upgrade Options:** Digital telephones may be upgraded for the following options.

- **Integrated Data Interface Unit (PDIU-DI2):** Users of digital telephones equipped with a PDIU-DI2 (Figure 16) connected to

a personal computer (PC) or ASCII terminal can make data calls to printers, personal computers, and other data devices, or voice calls, internal or external.

- **Add-on Module (ADM):** An ADM (Figure 21) can be connected to a 2000-series digital telephone to provide 20 Direct Station Selection buttons for STRATA DK16; and 10 Direct Station Selection buttons, eight personal Speed Dial buttons, one Night Transfer button, and one All Call Page button for STRATA DK8.
- **Off-hook Call Announce (DVSU):** DVSU-equipped digital telephones can receive Off-hook Call Announce. Every digital telephone can have this upgrade, which allows stations to receive intercom calls over their speaker while on another call. No extra wires to the telephone are required.
- **Loud Ringing Bell/Headset Interface (HHEU):** The HHEU provides interfaces for both a headset and a Loud Ringing Bell speaker—with Loud Ringing Bell, the speaker circuitry amplifies the ringing or voice announce of an incoming call.

**Toshiba VP Voice Messaging Systems:** Toshiba VP Voice Messaging Systems, which provide a wide array of useful and progressive features, are compatible with STRATA DK8 and DK16.



STRATA DK8 & DK16  
GENERAL DESCRIPTION  
MARCH 1993

**Stand-alone Data Interface Unit (PDIU-DS):**

PDIU-DSs (Figure 17) enable users to make switched data connections for modem pooling, printer sharing, and host/mainframe computer accessing. LEDs on the front panel of the PDIU-DS indicate the status of each call.

**Door Phone/Lock Control Unit (DDCB):** Door phones (MDFBs) (Figure 18) can serve a variety of functions. The door phone is often used with a door lock to screen visitors to a building. Door phones also can operate as a "hot line" calling link between an office and a warehouse. The door phone/lock control unit (DDCB) connects door phones and door locks to the system. The unit (Figure 19) has three

interfaces, two of which can each support a door phone and another which can support either a door phone or a customer-provided door lock. The DDCB connects only to digital telephone circuits.

**Direct Station Selection Consoles—STRATA DK16 only (DDSS and HDSS):** Consoles are dedicated answering stations that are normally used on systems that receive a heavy volume of incoming calls (Figure 20). They operate alongside a digital or electronic telephone and have 60 buttons which can be programmed for Direct Station Selection, central office (CO) lines, All Call Page, Night Transfer, and Speed Dial.

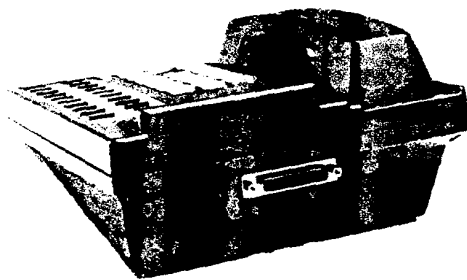


Figure 16  
INTEGRATED DATA INTERFACE UNIT  
(PDIU-DI2)

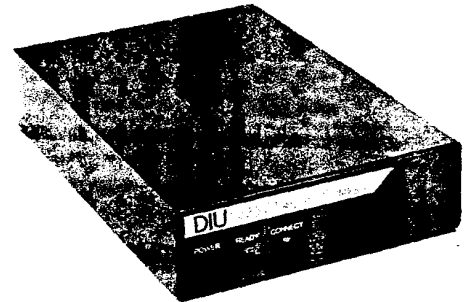


Figure 17  
STAND-ALONE DATA INTERFACE UNIT  
(PDIU-DS)

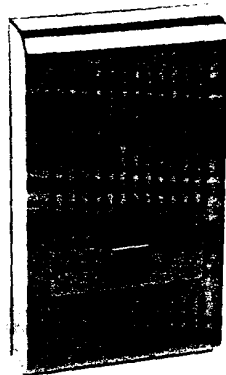


Figure 18  
DOOR PHONE (MDFB)



Figure 19  
DOOR PHONE/LOCK CONTROL UNIT (DDCB)

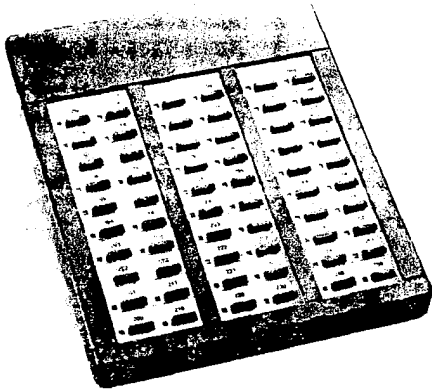


Figure 20  
60-BUTTON DIRECT STATION SELECTION  
CONSOLE (DDSS SHOWN)

**NOTE:**

Direct station selection consoles can be connected to STRATA DK16 only. There are two types: the digital direct station selection console (DDSS) can only be connected to designated Base KSU and PDKU digital telephone circuits, while the electronic direct station selection console (HDSS) can only be connected to designated circuits on the PEKU, installed in the Expansion KSU.

**Electronic Telephone (STRATA DK16 only):**

Users migrating upwards from older Strata systems can carry forward up to eight of their Electronic Telephones to use on a Strata DK16 with expansion cabinet. Most of the features available on the Digital Telephone are also available on the Electronic version; the most important exceptions are the lack of handset adjustable prompting, and LCD larger character size.

**External Speaker:** The HESB is a multifunctional, external 6-inch, 3-watt amplified speaker unit. It can be used as a paging speaker, an amplified talkback speaker, or Loud Ringing Bell.

**Customer-supplied Peripherals**

The STRATA DK8 and DK16 support many customer-supplied peripheral devices, several of which are listed below:

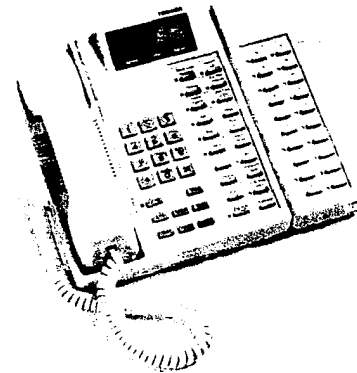


Figure 21  
20-BUTTON DIGITAL TELEPHONE WITH ADD-  
ON MODULE

- Voice Mail/Auto Attendant Device
- Dictation Equipment
- External Maintenance Modem
- Fax Machine
- Local Maintenance Terminal
- Alternate BGM Source
- Music-on-Hold/Background Music Source
- External Page Equipment

**Cabling and Connectors**

STRATA DK8 and DK16 utilize industry standard cabling and connectors to interface with central office (CO) lines, stations, and peripherals.

Stations use standard twisted pair cabling to connect to the system via the main distribution frame (MDF). Digital and standard telephones require just one pair, whereas electronic telephones (STRATA DK16 only) need two-pair (Table B).

Station printed circuit boards (PCBs) and circuits connect to stations and peripherals with a 25-pair amphenol connector via the MDF. CO line circuits interface with the public telephone network via modular connectors.

## 4 SYSTEM FEATURES

This section describes features that are available on a system-wide basis for both DK8 and DK16, except where otherwise noted (Table N).

### **Account Codes (Forced/Voluntary/Verified):**

Account Codes provide a method of tracking and categorizing central office (CO) calls on the Station Message Detail Recording (SMDR) report. They may be required before dialing calls (Forced) or can be optionally entered during calls (Voluntary). Codes can be as long as 15 digits and be Verified (specific numbers) or Nonverified (nonspecific numbers). A printout of each Account Code prints out on the SMDR report after each call.

#### *NOTE:*

*The 911 emergency number bypasses Forced Verified Account Code requirements. In addition, two other customer-assigned numbers (1 ~ 4 digits) may be programmed to bypass Forced Verified Account Code requirements.*

**Alarm Sensor (DK16 only):** The optional P10U/P10US printed circuit board (PCB) has a relay that can be connected to a customer-supplied alarm system. If the alarm system is tripped, the relay will cause the speakers of all electronic and digital telephones to emit a loud alert tone. The digital or electronic telephone alarm tone is reset from any station programmed with a designated button.

**All Call Voice Page:** A user can page all station speakers simultaneously. External speakers can also be part of an All Call Voice Page.

**Alternate Point Answer:** Users can answer a transferred central office (CO) line call from any station that also has the CO line.

**Amplified Conference Interface (DK16 only):** Provides interface for a customer-supplied amplifier. The amplifier is shared by all CO lines and will be automatically connected to a two-CO line or Direct Inward System Access (DISA) call to provide a louder sound level on

these types of calls. Requires a PEXC or PESU in the Expansion unit. A maximum of one amplifier per system can be connected. The amplifier is automatically switched into 2-CO line DISA or conference calls on a first call basis (only one amplified call at a time).

**Automatic Hold:** Automatic Hold enables a user to place an outside call appearing on a CO line button on hold simply by pressing another CO line or intercom button. The user can then alternate between the new and the old call simply by pressing the desired button. If this feature is not activated, users need to press the Hold button before accessing another line and switching between calls. This feature is optionally programmable for each telephone set.

**Automatic Hold/Park Recall:** Held calls can be programmed to ring back, after a designated time, the station that placed them on-hold. The recall time of each station can have an individual time set independently in programming for this feature, which helps ensure that held calls are always retrieved.

**Automatic Release from Hold/DISA:** The system can automatically disconnect a central office (CO) line on which a held party hangs up. Applicable to Direct Inward System Access (DISA) calls and voice mail calls also, Automatic Release is available on a CO-by-CO-line basis and operates only with COs that provide a disconnect signal.

**Automatic Station Relocation:** System users can relocate their stations and maintain the intercom numbers and features of their telephones, without having to reprogram their system.

**Background Music (BGM):** BGM can be sent to telephone speakers and external speakers. The BGM source can be applied flexibly. One music source can feed both types of speakers, or, in DK16 only, both can have their own source. The music source used for Music-on-hold can also be piped to telephone speakers.

An alternate BGM source can be connected to a QSTU in DK8, or a KSTU, PESU, PEKU or PSTU in DK16.

**Busy Station Transfer/Ringing:** When a station or external auto attendant device programmed for this feature transfers a call to a busy digital or electronic telephone with this feature, the transferring station or auto attendant device will receive a ringing signal (instead of a busy tone) and the called busy station will receive a distinct call waiting tone and LED indication. At this point the transferring station or auto attendant device will normally release and the call will camp-on the busy station, providing a distinctive camp-on tone and CO line LED flash. The busy station can then answer the transferred call after it releases, transfers, or places its current call on hold. Without Busy Station Transfer/Ringing, stations and auto attendant devices will receive busy tone when trying to transfer calls to busy stations; some auto attendant devices can't transfer calls after receiving busy tone, and the calls would be routed back to them.

**Centrex/PBX Compatible:** All system features are compatible with Centrex/PBX operation; including repeat of Centrex/PBX ringing cadence, one-button access to Centrex/PBX features, 1 ~ 4-digit station numbering plan, and delayed ringing to selected stations.

**Centrex Ringing Repeat:** The system mimics CO/Centrex/PBX cadences received from outside lines when it rings a called station. This capability enables STRATA DK8 and DK16 to use special CO/Centrex/PBX calling/callback features.

**CO Line Groups:** For easy access, various types of CO lines can be assigned to groups (normally for pooled line and Least Cost Routing (LCR) applications). All local lines, for example, can be assigned to one group and WATS lines in another group. Station users can access line groups with a dialing code or by pressing a feature button. Up to four CO

line groups for DK8 and up to eight CO line groups for DK16 can be created.

**CO Line Queuing:** A station user can use the Automatic Callback feature to queue up for a busy outgoing CO line. When the CO line finally becomes available, the system calls the station back. Queuing applies to single CO lines, CO line groups, and when calling via LCR.

**Conferencing:** A variety of Conferencing combinations are available to all station users, as listed below. Stations and central office (CO) lines can be added in any order.

- One or two stations and two CO lines
- Two or three stations and one CO line
- Four stations

**Credit Card Calling:** Callers can make credit card calls (0+ telephone number + credit card number) that bypass Toll Restriction. The calls are billed to the credit card, not the STRATA DK8 and DK16 central office (CO) line. The system requires that a specific quantity of digits are dialed for this call; otherwise, the call will be dropped within 20 seconds to prevent operator-placed calls that would be billed to the CO line.

**Data Calling:** STRATA DK8 and DK16 offers a sophisticated optional data switching capability that can interconnect a wide range of customer-supplied data equipment, including personal computers (PC), printers, and modems. Asynchronous data can be transmitted at speeds up to 19.2 kbps (Table M). The system provides four data security groups to restrict data calls between groups. Dialing by personal computer (both data and voice calls) as well as modem pooling and printer sharing is supported.

**DAY/NIGHT Modes:** The system has three available modes: DAY, DAY2 and NIGHT. Each mode can be assigned a distinct CO-to-station, CO-to-DISA, and CO-to-Remote Maintenance channel ringing arrangement. The system can be programmed with either two or

STRATA DK8 & DK16  
GENERAL DESCRIPTION  
MARCH 1993

three modes (which can be changed by any station programmed with a Night Transfer button):

<b>Two modes:</b>	<b>Three modes:</b>
DAY	DAY
NIGHT	DAY2
	NIGHT

**Delayed Ringing:** If a central office (CO) line call rings a station and is unanswered, alternate stations can be programmed to ring 12 or 24 seconds later. The stations that were ringing initially will continue after the Delayed Ringing begins. This feature is assigned on a line-by-line basis.

**Direct Inward System Access (DISA):** Outside callers using a Dual-tone Multi-frequency (DTMF) telephone can dial internal stations or outgoing central office (CO) lines directly, without going through a receptionist or operator. A security code can be assigned to prevent undesired access to CO lines. DISA is available to any number of CO lines.

**Distinctive CO Line/Intercom Ringing:** The incoming Central Office (CO) line ring pattern to both digital and electronic telephones is distinct from the intercom ring pattern, helping to indicate the nature of the call. This feature is optional for standard telephones.

**Door Lock Control:** Any telephone programmed with a door unlock button can unlock a customer-supplied electronic door lock just by pressing the button. The DK8 can support as many as two, and the DK16 can support up to three, each of which can have an associated button on designated digital and electronic telephones. (The DDCB, PIOU, and PIOUS can each support door lock control.)

**Door Phones (MDFB):** A door phone is frequently mounted near a building entrance and associated with a customer-provided door lock to help screen visitors. But it can serve other functions: it can also operate as a sound monitor—station users can call the door phone and listen to the surrounding area—or as a

"hot line" link. STRATA DK8 and DK16 can each support as many as six. Each door phone must be connected to a door phone/lock control unit (DDCB).

**DTMF and Dial Pulse CO Line Compatible**

The system works with either Dual-tone Multi-frequency (DTMF) or rotary dial pulse central office (CO) lines.

**DTMF Back Tone:** The system can be programmed to allow or prevent Dual-tone Multi-frequency (DTMF) tones from being returned to a digital or electronic telephone when its user dials on central office (CO) lines or sends digits to a voice mail device.

**DTMF Signal Time (80/160 milliseconds):** The duration of Dual-tone Multi-frequency (DTMF) tones that are sent via Speed Dial to CO lines and via automatic dialing to voice mail devices can be set at 80 or 160 milliseconds. The time can be set independently for CO line outdialing and for voice mail automatic dialing.

**Dual FCC Registration:** The system can be configured as either key or hybrid operation having separate FCC registration numbers for each type. The appropriate configuration for an individual system depends on its function. For more details, refer to General End Use Information, located in the front of this document.

**External Page:** Station users can make an announcement over an external paging device consisting of an amplifier and speaker by dialing a brief access code. The paging device connects directly to a 600 ohm output that is standard on the DK8 and DK16 Key Service Unit. The 600 ohm output is two-way and supports talk back amplifier applications. For STRATA DK16, paging zone options are also provided by the optional PIOU PCB in the Expansion Unit.

**External Page Zones (DK16 only):** The system can support as many as four external paging zones. Station users can access just one pag

zone or all of them simultaneously just by dialing a brief access code. The zones may be composed of customer-supplied speaker(s) and amplifier(s) which interface with a PIOUS printed circuit board in the Expansion Key Service Unit.

**Flexible Button Assignment:** Digital and electronic telephones have 10 or 20 buttons which may be flexibly programmed to access CO lines and features.

**Flexible Intercom Numbering:** A station intercom number can have as many as four digits, whereas it is normally two digits. The numbers can be assigned to any station port, and can be programmed in any sequence. Single-digit intercom numbers, such as 0, can be assigned to an attendant station.

**Flexible Line Ringing Assignment:** Each central office (CO) line can be programmed to ring (or not ring) any station in the system. A different ringing assignment scheme may be created for each of the three ringing modes—DAY, DAY2, or NIGHT. Stations assigned to ring can do so with any of the following three timing designations:

- **Immediate:** Stations assigned IMMEDIATE timing ring as soon as the CO line rings into the system.
- **Delay 1:** If stations with IMMEDIATE timing have not answered within 12 seconds, stations assigned DELAY 1 timing begin ringing also.
- **Delay 2:** If stations have not answered within 24 seconds, stations assigned DELAY 2 timing begin ringing also.

**Group Paging:** Digital and Electronic stations can be divided into as many as four paging groups. Any station user can make an announcement to one or all of these groups via station set speakers.

**Least Cost Routing (LCR):** Eight different plans may be designed to automatically place outgoing calls over the most cost-efficient routes. Three different LCR time schedules with their

own priority schedules can be set up for the business day. Stations can be grouped into one of four LCR classes, each with its own routing priority. Selected station users may have priority use of a line, even when the route with the lowest cost is not available. LCR is compatible with Automatic Busy Redial (ABR) and two-central office (CO) line Conference.

**Live System Programming:** Programming the system from an on-site or off-site location does not interrupt service. Service is only interrupted for PCB additions or changes.

**Memory Protection:** If the power fails, the system has an internal battery backup that protects data and the customer's programmed configuration. This information will be maintained within a powerless system for at least six years.

**Message Waiting:** Any station and most voice mail devices can leave a message waiting indication on an LED of a digital or electronic station. The station user can retrieve the message just by accessing the intercom and pressing the button associated with the LED. A station can store up to four indications.

**Modem Pooling:** This feature allows many telephone users to share modems. One or more standard, asynchronous type modem(s) that are compatible with industry-type "AT" commands can be connected to Stand-alone Data Interface Units (PDIU-DS) to form a modem pool. Users with digital telephones equipped with Data Interface Units can connect to the modems to place or receive external data calls. The modems can be connected to Strata DK standard telephone circuits and share external CO lines or they can be connected to dedicated CO lines.

**Music-on-hold:** A customer-supplied radio tuner, compact disc player, or other device can be used to send music or announcements to parties on-hold on central office (CO) or intercom lines.

STRATA DK8 & DK16  
GENERAL DESCRIPTION  
MARCH 1993

**Night Ringing Over External Page:** Incoming central office (CO) line or door phone calls can be programmed to ring over an external speaker when the system is in the Night mode. The call can be picked up from any telephone by dialing a brief access code. After-hours employees who are not near a ringing telephone are more likely to answer calls with this feature.

**Night Ringing Over Selected Page Zones (DK16 only):** Central office (CO) lines can be programmed to night ring over selected PIOUS page zones via customer-supplied paging equipment. The lines can be divided into two groups (Tenant 1 and Tenant 2) which can then be assigned to night ring over the selected zones.

**Non-blocking Talk Paths:** All CO and intercom lines can be used at the same time. The system can operate at full capacity at all times.

**Off-premises Station:** Off-site standard telephones can be part of the system, capable of accessing STRATA DK8 or DK16 features. Each off-site station requires a special line from the central office (OL13A or equivalent).

**Outgoing Call Restriction:** Stations can be selectively restricted from originating calls over any number of CO lines. The same stations can receive incoming calls over the restricted CO lines.

**Pooled CO Line Buttons:** Several central office (CO) lines can be pooled to appear under one digital or electronic telephone CO line button. The lines can be pooled in categories, e.g., WATS lines in one pool, regular lines in another.

**Power Failure Transfer:** A dedicated standard telephone can be connected to the DK8 Key Service Unit or DK16 Base Key Service Unit to provide emergency service if the system power fails. While system power is present, the telephone is inoperative. But, if the system power fails, the standard telephone will automatically connect to a designated central

office line (CO1), enabling access to the public telephone network. When system power is restored, the standard telephone will become inoperative again. Power failure transfer is independent of reserve (battery) power.

**Printer Sharing:** This feature allows many users to share one or more printers. Serial-type printers can be connected to Stand-alone Data Interface Units (PDIU-DS) to allow users with digital telephones equipped with Data Interface Units to connect (via Data Switching) to the printers. The printers can be almost any type (Laser, Ink Jet, Dot Matrix, etc.) but they must have a serial interface as opposed to the parallel type.

**Privacy/Non-privacy:** Central office (CO) lines can be private or non-private on a line-by-line basis. Private lines prohibit users from pressing a CO line button and accessing a line that is already in-use; users can do so on non-private lines. Private line users can change the mode with a privacy release button, enabling as many as three stations on a line.

**Relay Service Options:** The DK8 and DK16 Key Service units each contain relay contacts that can be programmed to provide control functions for external equipment. The DK8 KSU and DK16 Base KSU each have a single relay contact. This relay contact can be programmed for one of three functions. The DK16 PIOUS and PIOUS printed circuit boards (PCBs) each have two pairs of relay contacts. Each relay contact can be programmed for one of two functions. The PIOUS and PIOUS relay options are independent and can be used simultaneously with the DK16 Base Unit relay service to provide multiple control functions.

- **External Page Function:** A page over external speakers will mute Background Music that is being broadcast over the same speakers.
- **Door Lock Control Function (PIOUS and PIOUS relays only):** The relay will open a customer-supplied door lock for three or six seconds when a designated button is pressed on selected telephones.

- **Night Relay Function:** An answering machine or a night bell (or chime) will be activated when a call rings in.
- **Hold Relay Function:** A music-on-hold source will turn on when a call is placed on-hold.

**Remote Administration and Maintenance:**

System administration, programming, and maintenance can be performed from a personal computer or ASCII terminal at a remote location. In addition to the off-site equipment, with the DK8 the customer needs an external modem and optional QSMU PCB; with the DK16 the customer needs to have the expansion unit equipped with an optional PIOU or PIOUS printed circuit board and an IMDU piggy-back modem (or external modem) to access this feature, which does not interrupt system operation.

**Reserve Power (DK8):** One or two optional Reserve Power Battery and Chargers (HPFBs) can be connected to the system power supply as a power failure backup. If there is a power failure, STRATA DK8 automatically switches over to battery power without any interruption in operation. The built-in charger keeps the batteries charged during normal operation. Reserve power duration depends on the condition of the batteries and the system load. (See Table G for reserve power time.)

**Reserve Power (DK16):** Two customer-supplied 12-volt batteries (gel-cell and maintenance free) can be connected to the system power supply as a power failure backup. If there is a power failure, STRATA DK16 automatically switches over to battery power without any interruption to operation. A standard built-in charger circuit keeps the batteries charged during normal system operation. Reserve power duration depends on the condition of the batteries and the system load (Table G for reserve power time).

**Speed Dial:** Speed Dial enables users to dial frequently called telephone numbers quickly by just dialing a two-digit access code or by pushing a feature button. STRATA DK8, DK16 and

Centrex PBX feature access codes can also be stored in Speed Dial. There are two types of Speed Dial:

- **System Speed Dial:** A designated station can create up to 40 Speed Dial numbers that are available to every station.
- **Station Speed Dial:** Each station user can create as many as 40 of their own personal Speed Dial numbers.

**Station Hunting:** When a called station is busy, the call (data or voice) will hunt to an assigned station. If the assigned station is busy, the call hunts to the next assigned station, and so on. The hunting sequence can be either consecutive or non-consecutive, and is fully flexible. If a hunt station is call forwarded, calls to the station will ring at the forwarded destination—not the hunt destination. The call is eventually routed to the first idle station. Callers will receive busy tone if calling into a hunt group of which all stations are busy.

**Station Message Detail Recording**

**(SMR):** The system stores calling information that can be printed out with a printer or call accounting device connected to the optional QSMU PCB for STRATA DK8, or the PIOU or PIOUS PCB for STRATA DK16. The report includes time and length of call, as well as the called number. Customers can select what type of calls—all calls, outgoing only, long distance calls—they want to appear on the report. Account Code information can also be included.

**System Programming through Any**

**Station:** Any liquid crystal display 20-button digital (or electronic telephone for DK16) can be used to program the system. To prevent accidental entry, programmers must dial an access code prior to entering the programming mode. See Live System Programming.

**System Speed Dial:** The system can store as many as 40 Speed Dial numbers that can be accessed by all stations with either a two-digit access code or a flexible feature button. A designated station assigns these numbers, which can be telephone numbers, system fea-



STRATA DK8 & DK16  
GENERAL DESCRIPTION  
MARCH 1993

ture access codes, or Centrex/PBX feature access codes.

**Tandem CO Line Connections:** This feature allows up to two (DK8) or four (DK16) unattended line-to-line connections, freeing the originating station for other calls. For supervision purposes, the originating station must have both CO line button appearances to allow tandem operation.

**Tenant Service:** Two small businesses in the same office building can share a system. Tenants can have separate Least Cost Routing and Toll Restriction plans, Night Transfer ringing assignments, flexible door phone and CO line ringing assignments.

**Toll Restriction:** Stations can be individually restricted from making toll calls. Four restriction levels can be defined, each allowing or denying specific area and office codes, long distance information calls, international calls, and/or operator-assisted calls. Each station is assigned any one of the available restriction levels or no restriction. Individual CO lines can be defined as unrestricted.

**Toll Restriction Override by System Speed Dial:** System Speed Dial numbers can be programmed to override Toll Restriction. For instance, when employees need to access a toll number that falls into a restricted area/office code for work purposes, an employer can program the particular toll number as a system Speed Dial number. Even if their stations are restricted, they can access the number with speed dialing.

**Transfer Privacy:** Optional transfer privacy can be programmed system-wide. When transfer privacy is programmed and an outside call is answered by one station, then transferred to another station, it can only be answered by the second station or by a station with Call Pickup. Other stations cannot pick up the transferred call with a CO line button. See Alternate Point Answer earlier in this section and Call Pickup in the next section.

**Traveling Class of Service:** The normal Toll Restriction class of a station can be temporarily changed to another class. Each of the four Toll Restriction classes can be assigned a four-digit code. If one of these codes is entered at a station, the station will assume the class associated with the code for the next dialed number. The station will revert back to its normal Toll Restriction class for subsequent calls. Traveling Class codes can be added, deleted, or changed by users only from stations selected in programming.

**Unlimited Handsfree Intercom Paths:** All intercom lines can carry handsfree conversations simultaneously. Because intercom paths are non-blocking, the number is only limited by the amount of stations.

**Unrestricted Call Transfer over Intercom:** Any CO line call can be transferred to any station over the intercom line. A station does not need a specific CO line's appearance in order to answer the call.

**Voice Mail Interface:** The system can be configured with a Toshiba VP Voice Messaging System or a customer-supplied voice mail messaging system. The optional QSTU and QRCU PCB must be installed for voice mail operation for STRATA DK8. The KSTU and K4RCU must be installed for DK16. The following features are available with many systems.

- **Automated Attendant:** An integrated Automated Attendant can streamline the system's call answering capability.
- **Call Forward to Voice Mailbox:** Each telephone user can forward calls directly to a personal mailbox. The caller bypasses the usual sequence of voice mail commands and simply leaves a message after hearing a tone.
- **Message Waiting Indication:** When a message is recorded in a user's mailbox, the voice mail system automatically sets a message waiting indication—typically flashing LED—at the user's telephone.

- **Voice Mail Control via Station:** Station users can control voice mail equipment from their telephone dialpads.
- **Feature Integration:** The integration of special voice mail features in STRATA DK system software enables the systems to work together more efficiently.

**Voice or Tone Signaling:** The system can be programmed for either Voice Signaling or Tone Signaling as the standard method of intercom call signaling to a digital or electronic telephone. If Tone Signaling is selected, a station will ring when called. The called party will hear a tone burst and then the caller's voice if Voice Signaling is selected. A caller can always select the alternate method immediately after dialing the station number. Tone Signaling ensures privacy, while Voice Signaling enables quick communication.

## 5 TELEPHONE FEATURES

The following features are available to STRATA DK8 and DK16 station users. All of these features are available with digital telephones, and many with electronic and standard telephones (Table O).

**Account Code Button:** This button, which is available with digital and electronic telephones, enables users to enter Voluntary Account Codes (Verified or Nonverified) during conversations without interrupting the talk path. It can also be used to enter an optionally required Verified Account Code before dialing a long distance call.

**Add-on Module (ADM):** Each 2000-series digital telephone can be connected to an ADM to provide 20 Direct Station Selection buttons for STRATA DK16; and 10 Direct Station Selection buttons, eight personal speed dial buttons, one night transfer button, and one all call page button for STRATA DK8. The ADM connects to a host telephone; no additional KSU station port is required.

**Automatic Busy Redial (ABR):** Digital and electronic telephone users that dial a busy outside telephone number can set ABR and have the number redialed automatically at preprogrammed intervals. The system will call back the station when it successfully dials the non-busy number. ABR is compatible with Least Cost Routing. ABR requires the optional QRCU (for STRATA DK8) or K4RCU (for STRATA DK16).

**Automatic Callback (ACB):** Station users that call busy stations can set ACB and have the system call them back when the busy station comes available.

**Automatic Hold/Park Recall:** A CO line or intercom call placed on hold or parked will automatically recall the station at a preprogrammed elapsed time. A different time period can be selected for each station.

**Automatic Line Selection:** A digital or electronic telephone user with this feature will automatically access a CO line, CO line group, or the intercom whenever its handset is lifted or its speaker button is pressed.

**Automatic Park/Page:** With the push of a button on a digital or electronic telephone, a central office (CO) line can be parked and an external page announcement delivered. Station users can pick up the parked call after the page.

**Background Music with Station Control:** Digital and electronic telephone users can control Background Music (BGM) playing over their telephone speakers. The music may be switched on or off and the volume may be adjusted to suit the individual user. A designated station can control (on/off) BGM over external page speakers.

**Busy Override:** Upon calling a busy station and receiving a busy tone, a station user can dial a single-digit access code—or press a labeled feature button if calling from a properly configured digital or electronic telephone—that sends a tone burst to the called station. The

STRATA DK3 & DK16  
GENERAL DESCRIPTION  
MARCH 1993

busy station must be a digital or electronic telephone to receive this tone. 1000-series digital telephones and electronic telephones will receive the tone over their speaker, while 2000-series digital phones may optionally receive it over their handset or headset receiver as well as the speaker.

**Call Forward:** Outside and intercom calls to stations in the Call Forward mode are routed to an alternate station or voice mail device. Stations in this mode can originate calls as usual. There are five Call Forward modes, each described as follows:

- **All Calls:** All calls to a busy or idle station set with this mode will forward immediately, and the station will not ring.
- **Busy:** All calls to a busy station set with this mode will forward immediately. When the station is idle, incoming calls will ring normally.
- **No Answer:** Calls to an idle station set with this mode will ring for 12 seconds and then forward. When the station is busy, incoming calls will receive busy tone.
- **Busy/No Answer:** When a station is idle and in this mode, calls to it will ring for 12 seconds and then forward. When the station is busy, incoming calls will forward immediately.
- **Fixed:** Calls to an idle or busy digital or electronic telephone in this mode will forward immediately to a destination assigned in system programming.

**Call Park:** A station can place (park) a call on-hold, make another call, and then return to the parked call. This feature can also be used to park an outside central office (CO) line call and page a person internally to pick up the call by dialing an access code.

**Call Pickup:** By going off-hook and dialing an access code, any station can pick up the following type of calls:

- Calls on-hold or parked (selectively)
- Calls ringing at other stations
- An external page

- CO line ringing at night over external page or night bell
- Door phone calls

**Call Transfer with Camp-on:** A station user can transfer a call to a busy station, which will receive an alert tone indicating that a call is camped-on. If the busy station fails to answer, the camped on call will return to the station that transferred it.

**Call Transfer Immediate:** Transfers initiated with a designated Feature Prompting Soft Key on digital telephones can transfer immediately after the final digit of the destination is dialed. If the called station is not available or busy, the call will camp-on to it. This feature is a real aid for stations that have to process a large number of calls.

**CO/Centrex/PBX Feature Buttons:** System Speed dial buttons on digital and electronic telephones can be programmed with access codes, plus any flashes or pauses necessary to access features through a host switching system.

**Computer Auto Dialing:** Voice and data calls can be dialed from the keyboard of a personal computer connected to a digital telephone equipped with an integrated data interface unit (PDIU-DI2). Standard computer dialing protocol is used, and calls can be internal or external (no modem required).

**Continuous DTMF Signal Time:** The DTMF dial signal sent to a central office (CO) line or voice mail/auto attendant device will last as long as a 2000-series digital telephone user presses a button on the dialpad. This feature is not available with electronic, standard, or 1000-series digital telephones; or, 2000-series digital telephone connected to PDKU1 circuits.

**Data Button:** Digital telephones can have a data button that allows manual dialing of internal data calls.

**Direct Station Selection (DSS) Buttons:** A digital or electronic telephone user can ring a selected station by pressing a flexible feature button assigned with DSS. The LED associated with the button provides the busy status of the station. Each flexible button can be assigned as a DSS button to a different station.

**Direct Station Selection Console Features (STRATA DK16 only):** Digital and electronic telephones can operate with direct station selection consoles, which offer the following features:

- Automatic Line Hold
- Call Forward Override
- Feature Buttons
  - All Call Voice Page
  - CO line
  - Direct Station Selection
  - Night Transfer
  - Speed Dial
- Voice or Tone Signaling

**DISA Security Code Revision:** Digital and electronic telephones selected in programming can revise the Direct Inward System Access (DISA) security code.

**Distinctive LED Color Indications:** Central office (CO) line LEDs illuminate as red or green to help digital telephone users determine the status of calls. Electronic telephone LEDs are always red when they light.

**Distinctive LED Flash Indications:** LEDs on digital and electronic telephones will flash at varying rates to indicate calling status.

**Distinctive Station Ringing:** Digital and electronic telephones can have one of two ring tones for incoming central office (CO) line calls. This helps station users identify if their telephone is ringing.

**Do Not Disturb (DND):** Station users with digital and electronic telephones can activate this feature to prevent intercom and transferred calls from ringing them. Callers will hear a fast

busy tone. To ensure that important calls are not missed, direct CO line calls will mute ring DND stations. Stations can make calls while in the DND mode.

**Do Not Disturb (DND) Override:** Privileged station users from digital, electronic, and standard telephones can override stations in the DND mode with a tone that indicates that somebody is trying to contact them.

**DP/DTMF Mode Change:** This feature allows a digital and electronic telephone user to change the central office (CO) out-dialing signal mode from dial pulse (DP) to Dual-tone Multi-frequency (DTMF) by pressing a feature button.

**Exclusive Hold:** Exclusive Hold enables a digital or electronic telephone user to place a call on hold so that the call can only be picked up at that station or at another station using Call Pickup. No other station can pick up the call by simply pressing the line button of the call on hold.

**Executive Override:** Privileged station users can enter any conversation in the system by dialing an access code. An optional warning tone notifies conversing parties that an additional party is about to enter their conversation. Executive Override can be blocked selectively to any station in system programming to provide security for modem (data) calls, voice mail calls, FAX calls, etc.

**Feature Prompting Soft Keys:** As an alternative to dialing access codes and using feature buttons, station users with liquid crystal display (LCD) digital telephones can use keys beneath their LCDs to easily access features. The abbreviated name of a different feature will appear on the LCD above each of the keys during a call, in either the ring or talk state. Users can select the feature they want just by pressing the key below it. The features appearing on the LCD change to provide the most logical options during the varying call modes.

STRATA DK8 & DK16  
GENERAL DESCRIPTION  
MARCH 1993

**Flash Button:** An optional button on a digital or electronic telephone can be used either to disconnect a central office (CO) line and regain CO dial tone, or to gain access to Centrex/PBX features.

**Handsfree Answerback:** When a voice-announced intercom call comes in on a digital or electronic telephone, users can answer without lifting the handset or touching any button.

**Hearing Aid Compatible:** All Toshiba telephones are hearing aid compatible.

**Liquid Crystal Display Features:** The following features operate on all LCD model telephones:

- Feature Prompting Soft Keys (for digital telephones)
- Alphanumeric Messaging
  - Busy Station Messaging
  - Called Station Messaging
  - Calling Station Messaging
  - Group Station Messaging
- Busy Lamp Field Indication
- CO Line Identification
- Intercom Name/Number Display
- Speed Dial Memo
- Station Identification
- Timed Reminders with Messages

**Microphone Control Button:** Digital and electronic telephones can be programmed with a button that turns the telephone microphone on and off. The button can also enable and disable handsfree answerback, thus allowing or blocking the caller's ability to monitor the sound in the area close to your telephone.

**Modem Button:** This optional multifunctional button allows a digital telephone user to reserve a modem from a pool and to switch from a voice to a data call. Its LED indicates the availability of modems.

**Modular Handset and Line Cords:** All Toshiba telephones are equipped with modular handset and line cords.

**Modular Headset Interface:** Digital and electronic telephones may be optionally equipped with a modular headset jack.

**Off-hook Call Announce (OCA):** Optional OCA allows a station user to call and speak over the speaker of an off-hook, busy digital or electronic telephone. The called station user can respond over his or her microphone without interrupting his or her original conversation.

**On-hook Dialing:** Users of digital and electronic telephones can dial calls without lifting the handset, thus freeing their hands for other tasks. Dial tone, dial pulsing, ringing, and the voice of the answering party are all amplified over the telephone speaker. The handset doesn't need to be lifted until after the party answers.

**Pooled Line Buttons:** A group of central office (CO) lines can appear under one button on digital and electronic telephones. The system can support as many as four groups (DK8) or eight groups (DK16). A station can have as many as four buttons for the same group to facilitate the handling of several calls in the same group.

**Privacy Button:** This programmable button for digital and electronic telephones denies Privacy Override on common CO lines. It does not block Executive or Busy Override.

**Privacy Override:** Digital and electronic telephones enabled in programming can enter a CO line call on a button in the private mode. Before the overriding station enters the conversation, an optional warning tone notifies conversing parties: As many as two stations can override a call with Privacy Override. Privacy Override can be blocked selectively to any station in system programming, providing security for modem, fax, and voice mail calls.

**Privacy Release Button:** CO lines that appear on stations are in private mode by default. If a digital or electronic telephone user accesses a common CO line and presses this button, then any other station (including stations without the Privacy Override option) can enter that line.

**Private CO Lines:** The system can be programmed to allow certain "private" CO lines to appear only on one digital or electronic telephone and be accessed only by that station.

**Push-Button Dialing:** All Toshiba telephones are equipped with push-button dialpads.

**Release Button:** Users can disconnect from a call and become idle just by pressing an optional button on their digital and electronic telephones; going on-hook or pressing the hookswitch is not required. This feature is useful for headset-equipped stations.

**Remote Retrieval of Held/Parked Calls:** Calls placed on hold or parked by a station can be picked up selectively by another station by pressing a feature button or dialing an access code.

**Repeat Last Number Dialed:** The last number dialed by a station user is stored in system memory, and may be redialed automatically by accessing a CO line and pressing a Redial button.

**Ringling Line Preference:** A digital or electronic telephone user with this feature can answer an incoming CO line call ringing at their station just by lifting the handset or pressing the speaker button, without having to press the button or dial the access code associated with that line.

**Saved Number Redial:** After dialing a telephone number, a user can "save" that number just by pressing a feature button on their digital or electronic telephone. The number can be redialed later by pressing the feature button again.

**Speed Dial Buttons:** This feature enables digital and electronic station users to dial telephone numbers just by pushing one button. There are two types of Speed Dial buttons, described as follows:

- **Station Speed Dial:** Station users can store their own personal telephone numbers on Station Speed Dial Buttons.
- **System Speed Dial:** System Speed Dial buttons are fixed, typically on which numbers called by a number of station users, are stored. To preserve the order of these buttons, only a designated station user can change the numbers associated with them.

**NOTE:**

*Standard telephone users can dial System and Station Speed Dial numbers with access codes.*

**Timed Reminder:** Five separate "reminders" can be set at any digital or electronic telephone. A reminder tone sounds at the pre-set time. Each reminder may be set to ring only once, or at the same time daily. A user programmed message may be displayed on the LCD with each reminder.

**Toll Restriction Override Code Revision:** Privileged digital and electronic telephone stations can change Toll Restriction Override Codes.

**User Programmable Feature Buttons:** This feature enables digital and electronic telephone users to program their personal Station Speed Dial buttons to dial feature access code sequences, as well as telephone numbers. Feature button functions Hold, Intercom, and Conference/Transfer can be stored, and more than one feature can be linked under one button or code.

**Verified Account Code Revision:** Privileged digital and electronic telephone stations can change verified account codes.

STRATA DK8 & DK16  
 GENERAL DESCRIPTION  
 MARCH 1993

GENERAL

<b>Primary power</b> Input AC AC frequency Power	85 ~ 135VAC 50/60 Hz DK8-46 watts maximum. DK16-75 watts maximum								
<b>Environmental specifications</b> Operating temperature Operating humidity Storage temperature	32 ~ 104°F (0 ~ 40°C) 20 ~ 80% relative humidity without condensation - 4 ~ 158°F (-20 ~ 70°C)								
<b>Power supply</b> DC voltage output specification	<table style="width: 100%; border: none;"> <tr> <td style="text-align: center; border: none;"><u>DK16</u></td> <td style="text-align: center; border: none;"><u>DK8</u></td> </tr> <tr> <td style="border: none;">-24VDC: (-26.3 ~ -27.8VDC)</td> <td style="border: none;">+24VDC: (+26.3 ~ +27.8VDC)</td> </tr> <tr> <td style="border: none;">+5VDC: (+4.5 ~ +5.5VDC)</td> <td style="border: none;">+5VDC: (+4.5 ~ +5.5VDC)</td> </tr> <tr> <td style="border: none;">-5VDC: (-4.5 ~ -5.5VDC)</td> <td style="border: none;">Note: +5V converter on KSU PCB</td> </tr> </table>	<u>DK16</u>	<u>DK8</u>	-24VDC: (-26.3 ~ -27.8VDC)	+24VDC: (+26.3 ~ +27.8VDC)	+5VDC: (+4.5 ~ +5.5VDC)	+5VDC: (+4.5 ~ +5.5VDC)	-5VDC: (-4.5 ~ -5.5VDC)	Note: +5V converter on KSU PCB
<u>DK16</u>	<u>DK8</u>								
-24VDC: (-26.3 ~ -27.8VDC)	+24VDC: (+26.3 ~ +27.8VDC)								
+5VDC: (+4.5 ~ +5.5VDC)	+5VDC: (+4.5 ~ +5.5VDC)								
-5VDC: (-4.5 ~ -5.5VDC)	Note: +5V converter on KSU PCB								
<b>Battery charger characteristics</b> (DK16 only)	Charger: current limiting Nominal float voltage: 2.275 volts/cell Charge current: 0.7 amps maximum Battery discharge cut-off voltage: 20.5 ± 0.5VDC								
<b>QSTU, KSTU, PSTU or PESU (circuits 1 &amp; 2)</b>  Ring voltage  Ringing capability	Square wave output with high/low option jumper:  Low position, 130 ± 20VDC peak-to-peak (no-load) High position, 190 ± 25VDC peak-to-peak (no-load)  Two ringers maximum per circuit, high or low position								

Table A  
 DK8 & DK16 GENERAL REQUIREMENTS

Device	Max Loop Resistance (Including Device)	Max Distance from KSU to Device	Number of Wire Pairs <sup>1</sup>
Digital Telephones	40 ohms	1000 ft. (303 m)	1-pair <sup>3</sup>
DDSS Consoles (DK16 only)	40 ohms	1000 ft. (303 m)	1-pair
PDIU-DI2	40 ohms	1000 ft. (303 m)	Shares digital telephone wire-pair <sup>3</sup>
PDIU-DS	40 ohms	1000 ft. (303 m)	1-pair
DDCB	40 ohms	1000 ft. (303 m)	1-pair
ADM	40 ohms	1000 ft. (303 m)	Shares digital telephone wire-pair <sup>3</sup>
Electronic Telephones (DK16 only)	40 ohms	1000 ft. (303 m)	2-pair <sup>2</sup>
HDSS Consoles (DK16 only)	20 ohms	500 ft. (152 m)	2-pair
Standard Telephones, Voice Mail, Auto Attendant, etc.	300 ohms	Approx. 3000 ft. (909 m) with 150 ohm device. See manufacturer's product specifications for exact resistance of device.	1-pair

NOTES:

1. Use 24 AWG twisted pairs.
2. 3-pair required for OCA.
3. 2-pair wiring or optional telephone power supply is required to achieve maximum range with ADM, OCA, Headset, or Data Interface Unit.

Table B  
 DK8 & DK16 STATION LOOP REQUIREMENTS

PCB/Interface	Facility Interface Code	USOC Jack	Ringer Equivalence
<b>Loop Start Lines</b>			
DK8 KSU	02LS2	RJ11	0.2B
QCDU	02LS2	RJ11	0.2B
DK16 Base KSU	02LS2	RJ11	0.2B
KCDU	02LS2	RJ14C	0.2B
PCOU	02LS2	RJ14C	0.2B
<b>Standard Telephone Circuits Off-premises Station</b>			
DK8 KSU (QSTU)	OL13A	RJ21X	N/A
DK16 Base KSU (KSTU)	OL13A	RJ21X	N/A
PSTU	OL13A	RJ21X	N/A
PESU (circuit 1 and 2)	OL13A	RJ21X	N/A

Table C  
 NETWORK REQUIREMENTS



STRATA DK8 & DK16  
 GENERAL DESCRIPTION  
 MARCH 1993

CO Line	Idle digital telephones	Ring tone 1	500/640 Hz. modulated by 10 Hz. 1 sec. ON—3 sec. OFF
		Ring tone 2	600/800 Hz. modulated by 10 Hz. 1 sec. ON—3 sec. OFF
		Ring transfer	540/760 Hz. modulated by 10 Hz. 1 sec. ON—3 sec. OFF
	Busy station (queuing)		2000 Hz. modulated by 10 Hz. 1 sec. ON—3 sec. OFF
	Busy station Transfer (camp-on)		2000 Hz. modulated by 10 Hz. one-time 1 sec. tone burst
	Standard telephone or voice mail port: Normal ring option:		20 Hz. 1 sec. ON—3 sec. OFF
Distinctive ring option (standard telephone):		0.4 sec. ON—0.2 sec. OFF—0.4 sec. ON—3 sec. OFF	
DISA line calls	To busy station		400 Hz, 0.25 sec. ON—0.25 sec. OFF or 400 Hz, 0.50 sec. ON—0.50 sec. OFF (programmable option)
Intercom Line Calls	Tone first (DKT/EKT) ring signal		500 Hz. 1 sec. ON—3 sec. OFF
	Door phone	A & C	870 Hz. 1 sec./710 Hz, 2.5 sec. (1 or 5 rings)
		B	870 Hz. 0.5 sec./710 Hz, 2.5 sec. (1 or 5 rings)
	Busy override/DND override		2400 Hz, 1 sec. ON—3 sec. OFF
	Dial tone (intercom)		400 Hz, continuous
	Ringback		400/480 Hz, 1 sec. ON—3 sec. OFF
	Busy		400 Hz, 0.25 sec. ON—0.25 sec. OFF
	Do not disturb		400 Hz. 0.125 sec. ON—0.125 sec. OFF
	Voice page warning		500 Hz, 1 sec. ON (via electronic telephone speaker)
	OCA warning		500 Hz, 1 sec. ON only (via electronic telephone speaker)
	Executive/privacy override warning		500 Hz, 1 sec. ON only (via handset or speaker)
	Hold recall		2400 Hz, modulated by 10 Hz, 1 sec. ON—1 sec. OFF
Standard telephone ringing		20 Hz, 1 sec. ON—3 sec. OFF	
Voice Mail Special Tones	Answer: DTMF "A" Disconnect: DTMF "D" Recall: DTMF "B"	80 or 160 msec., dual-tone	
Special Confirma- tion Tones	Verified account code confirmation tones <sup>1</sup>	Code valid	400 Hz, 0.5 sec. ON
		Code not valid	400 Hz, 0.125 sec. ON—0.125 sec. OFF—0.125 sec. ON
	Station option programming confirmation tones (call forward, timed reminders, etc.)		400 Hz. 1 sec. ON

NOTES:

1. Tones are sent only to the station that enters the code, not to the outside party.

Table D  
 SYSTEM TONES

Item	Supports	Connector Type	Standard	Optional
Digital Telephone Circuits (4)	<ul style="list-style-type: none"> <li>Digital Telephones (with or without PDIU-DI2 or ADM)</li> <li>Stand-alone Data Interface Units (PDIU-DS)</li> <li>Door Phone Lock/Control Unit (DDCB)</li> </ul>	25-pair Amphenol	✓	
CO Line Circuits (2)	<ul style="list-style-type: none"> <li>Loop Start CO Lines</li> </ul>	RJ11 Modular	✓	
Power Failure Transfer Interface	<ul style="list-style-type: none"> <li>Standard Telephone (one)*</li> </ul>	RJ11 Modular	✓	
Battery Backup Interface	<ul style="list-style-type: none"> <li>Optional HPFB (one or two per system)</li> </ul>	Proprietary Cable/Connector	Interface	HPFB and cable
Music-On-Hold Interface	<ul style="list-style-type: none"> <li>Music-on-hold/BGM Source*</li> </ul>	RCA Jack	✓	
600 Ohm page Interface	<ul style="list-style-type: none"> <li>Amplifier/Speaker*</li> </ul>	RCA Jack	✓	
CC line CKT (1)/ Digital Telephone CKT (2) (QCDU) (max. 2 QCDU per system)	<ul style="list-style-type: none"> <li>Digital Telephones (with or without PDIU-DI2 or ADM)</li> <li>Stand-alone Data Interface Units (PDIU-DS)</li> <li>Door Phone Lock/Control Unit (DDCB)</li> </ul>	25-pair Amphenol		✓
	<ul style="list-style-type: none"> <li>Loop Start CO Line</li> </ul>	RJ11 Modular		
Standard Telephone Interface Unit (QSTU) <ul style="list-style-type: none"> <li>2 standard telephone circuits (max.) QSTU per system</li> </ul>	<ul style="list-style-type: none"> <li>Standard Telephones*</li> <li>Other Single-line Devices*</li> <li>Fax Machine*</li> <li>Voice Mail Devices</li> <li>Alternate BGM source*</li> </ul>	25-pair Amphenol		✓
DTMF/ABR Tone Receiver (3-Receiver CKT per QRCU)	<ul style="list-style-type: none"> <li>Automatic Busy Redial</li> <li>Standard telephone ports</li> <li>DISA</li> </ul>	Internal		✓
Control Relay	One of the following: <ul style="list-style-type: none"> <li>Night Relay</li> <li>External Page Mute</li> <li>MOH Control Relay</li> </ul>	25-pair Amphenol	✓	
Conference Circuit Interface Unit (QCNU)	<ul style="list-style-type: none"> <li>2 Simultaneous Conferences</li> </ul>	Internal	✓	
SMDR/TTY Interface Unit (QSMU)	<ul style="list-style-type: none"> <li>SMDR Printer*, or</li> <li>TTY* or</li> <li>Modem*</li> </ul>	6-pin Modular (PPTC adaptor)		✓

\* Customer supplied equipment.

Table E  
 DK8 KEY SERVICE UNIT COMPONENTS

STRATA DK8 & DK16  
 GENERAL DESCRIPTION  
 MARCH 1993

Item	Supports	Connector Type	Standard	Optional
Digital Telephone Circuits (8)	<ul style="list-style-type: none"> <li>• Digital Telephones (with or without PDIU-DI2 or ADM)</li> <li>• Stand-alone Data Interface Units (PDIU-DS)</li> <li>• Door Phone Lock/Control Unit (DDCB)</li> <li>• Digital Direct Station Selection Console (DDSS)</li> </ul>	25-pair Amphenol	✓	
CO Line Circuits (4)	Loop Start CO Lines	RJ11 Modular	✓	
Power Failure Transfer Interface	Standard Telephone (one)*	RJ11 Modular	✓	
Battery Backup Interface with built-in charger	Two 12-volt Batteries*	Proprietary Connector/Cable	✓	Cable and Batteries
Music-On-Hold/BGM Interface	Music-on-Hold/BGM source*	RCA Jack	✓	
600 Ohm page Interface	Amplifier/Speaker*	RCA Jack	✓	
Standard Telephone* Interface Unit (4-Circuit) (KSTU)	<ul style="list-style-type: none"> <li>• Standard Telephones*</li> <li>• Other Single-line Devices*</li> <li>• Alternate BGM Source*</li> <li>• Fax machine*</li> <li>• Voice mail devices*</li> </ul>	25-pair Amphenol		✓
DTMF/ABR Receiver (K4RCU)	<ul style="list-style-type: none"> <li>• Automatic Busy Redial</li> <li>• Standard Telephone Ports</li> <li>• Interprets DTMF Tones</li> <li>• DISA</li> </ul>	Internal		✓
Feature Cartridge	<ul style="list-style-type: none"> <li>• Future Feature Upgrades</li> </ul>	Internal		✓
Control Relay	Choice of one: <ul style="list-style-type: none"> <li>• MOH Source Control</li> <li>• Night Bell Control</li> <li>• BGM Mute Control</li> </ul>	25-pair Amphenol	✓	

\*Customer supplied equipment.

**Table F**  
**DK16 BASE KEY SERVICE UNIT COMPONENTS**

DK16	Base Unit		Expansion Unit		
	No KSTU	KSTU	1	2	3
Quantity of installed PCBs			1	2	3
Approximate (-24v) current drain (DC amperes)	1.7	2.4	3.1	3.8	4.5
Estimated battery operation time (in hours)	45.0	31.0	23.0	19.0	16.0

Time is estimated with the following considerations:

1. Batteries have full charge at start of operation.
2. Batteries (2) are connected in series.
3. Batteries are 12VDC, rated at 80 amp/hours each.
4. System is operating at full load traffic with LCD phones.
5. Batteries used for this test are gel-cell and maintenance-free. Reserve duration will vary depending upon battery type, age, and manufacturer. These figures should be used as an estimate.
6. A maximum of three Expansion Key Service Unit slots may be occupied at one time. The fourth slot is reserved for future features.

DK8 (Fully Loaded)	Estimated Battery Time (hours)
One HPFB	.5 ~ 1.0
Two HPFBs	1.0 ~ 2.0

1. Reserve power time varies with system call traffic.
2. Batteries must have full charge at start of operation.
3. HPFB recharge time is 48 hours per HPFB.

**Table G**  
**DK8 & DK16 TYPICAL RESERVE POWER DURATION ESTIMATES**

STRATA DK3 & DK16  
 GENERAL DESCRIPTION  
 MARCH 1993

PCB	Circuits per PCB	Interfaces	Connector
PDKU	8 digital telephone circuits	<ul style="list-style-type: none"> <li>• Digital telephones (with or without PDIU-DI2 or ADM)</li> <li>• DDSS console</li> <li>• PDIU-DSs</li> <li>• DDCB</li> </ul>	25-pair Amphenol
PEKU	8 electronic telephone circuits	<ul style="list-style-type: none"> <li>• Electronic telephones</li> <li>• HDSS console</li> <li>• Alternate BGM source*</li> <li>• EOCU PCB for OCA</li> <li>• External Conference Amplifier*</li> </ul>	25-pair Amphenol
PSTU	8 standard telephone circuits	<ul style="list-style-type: none"> <li>• Standard telephones*</li> <li>• Voice mail ports*</li> <li>• Off-premises stations*</li> <li>• Other similar devices*</li> <li>• Alternate BGM source*</li> </ul>	25-pair Amphenol
PESU	2 standard telephone/ 4 electronic telephone circuits (standard/electronic telephone ports)	Standard: same as PSTU Electronic: same as PEKU except PESU does not support HDSS console	25-pair Amphenol
PCOU	4 CO line circuits (lines)	• Central Office loop start lines	RJ14C modular
KCDU	2 CO line circuits/ 4 digital telephone circuits	<ul style="list-style-type: none"> <li>• Central Office loop start lines</li> <li>• Digital circuits same as PDKU, except no DDSS</li> </ul>	RJ14C Modular (CO Line circuits) 25-pair amphenol (digital telephone circuits)
PIOU, PIOUS	See Table I	See Table I	25-pair amphenol (PIOU) Spring clip terminal (PIOUS)

\*Customer supplied equipment.

**Table H**  
**DK16 EXPANSION KEY SERVICE UNIT COMPONENTS**

PIOU/PIOUS Interface Option	PIOU	PIOUS
*Zone Page Interface (unamplified, 4 zones)	X	
*Night Transfer or Music-on-Hold Control Relay	X	X
*Door Lock or External Amplifier Control Relay	X	X
*Alarm Sensor	X	X
*SMDR output (RS-232/6-wire modular connector)	X	X
*Maintenance Port for a Local ASCII Terminal or External Modem (RS-232/6-wire modular connector)	X	X
Remote Maintenance Modem (IMDU subassembly, no external connector)	X	X

NOTE: X = the option is provided.

\* = Customer supplied equipment required.

**Table I**  
**DK16 PIOU/PIOUS INTERFACE OPTIONS**

FEATURES	MAXIMUM CAPACITIES	
	DK8	DK16
Personal Messages	10	10
System Messages	40	40
CO Line Groups	4	8
Conference Parties	4/3	4
External Page Zones	N/A	4
Internal Page Groups	4	4
Personal Message LCD Telephones	8	16

FEATURES	MAXIMUM CAPACITIES	
	DK8	DK16
Simultaneous Conference	2	3
Line-to-line Conference (unsupervised)	2	4
Station Speed Dial	40	40
System Speed Dial	40	40
Verified Account Code	100	300
Amplified Two-CO Line Conference	N/A	1

Table J  
 DK8 & DK16 FEATURE CAPACITIES

ITEM	BASIC SYSTEM	EXPANDED SYSTEM	REQUIRED CIRCUIT TYPE/INTERFACE
Digital Telephones	4	8	Digital Circuit
Stand-alone Data Interface Units (PDIU-DSs)	4	8	Digital Circuit
Integrated Data Interface Units (PDIU-DIs)	4	8	Digital Telephone
Digital Door Phone/Lock Control Unit (DDCB)	2	2	Digital Circuit
Door Phones (MDFBs)	6	6	DDCB
Door Lock	2	2	DDCB
Add-on Module (ADM)	4	8	Digital Telephone
Alternate BGM Source	0	1	QSTU
Music-on-Hold/BGM Source	1	1	KSU MOH Interface
Standard Telephone	0	2	Standard Circuit (QSTU)
External Page Amplifier	1	1	KSU 600 $\Omega$ Page Interface
Night Bell or Page Mute or MOH Device Control	1	1	KSU Control Relay

Table K  
 DK8 PERIPHERAL CAPACITY

STRATA DK2 & DK16  
 GENERAL DESCRIPTION  
 MARCH 1993

ITEM	BASE SYSTEM	EXPANDED SYSTEM	REQUIRED CIRCUIT, TYPE/INTERFACE
Digital Telephones	8	16	Digital Circuit
Stand-alone Data Interface Units (PDIU-DSS)	8	16	Digital Circuit
Integrated Data Interface Units (PDIU-DI2s)	8	16	Digital Telephone
Digital Door Phone/Lock Control Unit (DDCB)	1	2	Digital Circuit
Door Phones (MDFBs)	3	6	DDCB
Door Lock	1	3	DDCB and PIOUS or PIOUS
Digital Direct Station Selection Console (DDSS)	1	2	Digital Circuit
Add-on Module (ADM)	8	16	Digital Telephone
Alternate Background Music Source	1	1	KSTU, PEKU, PESU or PSTU
Music-on-Hold/BGM Source	1	1	Base KSU MOH Interface
Electronic Telephones	0	8	Electronic Circuit PEKU or PESU
Electronic Direct Station Selection Console (HDSS)	0	1	Electronic Circuit (PEKU)
Standard Telephone	4	12	Standard Circuit (KSTU, PESU, or PSTU)
External Amplifier For Two-CO Line Conference	0	1	Electronic Circuit PEKU or PESU
External Page Amplifier	1	4	Base Unit 600 $\Omega$ Page Interface (1) PIOUS Page Zone Relays (4)
Night Bell or Page Mute or MOH Device Control	1	1	KSU Relay or PIOUS/PIOUS Relay

**Table L**  
**DK16 PERIPHERAL CAPACITY**

ITEM	SPECIFICATIONS
Terminal Interface Specification	RS-232C (EIA) V.24/V.28 (CCITT)
Data Transmission Speed	Up to 19.2kbps. asynchronous
Flow Control	Half and full duplex. utilizing RTS/CTS/CD control leads
Automatic Dialing	Based on AT commands: <ul style="list-style-type: none"> <li>• Data speed of AT command is 300, 600, 1200, 2400, 4800, or 9600</li> <li>• Data bit: 7 or 8 bits</li> <li>• Stop bit: 1 or 2 bits</li> <li>• Parity bit: even, odd, or no parity</li> </ul>
Maximum Distance: KSU to DKT/DIU or DIU stand-alone	<ul style="list-style-type: none"> <li>• With standard power supply: 1000 feet with 2-pair (24 AWG)</li> <li>• With battery back-up: 675 feet with 2-pair, or 1000 feet external power to telephone</li> </ul>
Number of Wire Pairs	1-pair or 2-pair (24 AWG)
LED Indicators (stand-alone DIU only)	POWER: Lights when power is on READY: Lights when DTE or DCE and DIU are ready CONNECT: Lights when DIU is in transmission or ringing mode
Automatic Disconnect Timeout	Forced hang up when DIU does not detect Data on SD or RD within nine minutes
LSI Technology	<ul style="list-style-type: none"> <li>• One-chip CPU with a clock frequency of 12.288MHz</li> <li>• Memory: ROM, 16kb; RAM, 512kb</li> <li>• Ping-pong transmission: LSI with bearer transmission rate of 512kbps, 2B+D-like link</li> </ul>
STRATA DK Option Compatibility	Digital telephones with integrated PDIU-DI2 <ul style="list-style-type: none"> <li>• No wall mount</li> <li>• No DVSU (off-hook call announce)</li> <li>• Compatible with associated digital DSS console</li> <li>• Compatible with headset (HHEU)</li> </ul>
Cabling/Connectors	<ul style="list-style-type: none"> <li>• DIU to DTE/DCE device: 9-wires, 50 feet maximum, 24 AWG: compatible with RJ-45, 8-wire modular cable and RJ-45 to DB25 RS-232 modular adaptors</li> <li>• Stand-alone DIU: RJ11 modular connector</li> <li>• Integrated DIU: connected inside digital telephone</li> <li>• Stand-alone DIU jumper plugs enable straight wire connection to a DTE or DCE device without null-modem cables or adaptors</li> </ul>

Table M  
 DATA INTERFACE SPECIFICATIONS



## STANDARD

---

- Account Codes (Forced/Voluntary/Verified)
- All Call Voice Page
- Alternate Point Answer
- Automatic Hold/Park Recall
- Automatic Hold
- Automatic Release from Hold/DISA
- Automatic Station Relocation
- Background Music Interface\*
- Busy Station Ringing/Transfer
- Centrex/PBX Compatible
- Centrex Ringing Repeat
- CO Line Groups
- CO Line Queuing
- Conferencing
- Credit Card Dialing
- DAY/NIGHT Modes
- Delayed Ringing
- Distinctive CO Line/Intercom Ringing
- DTMF Back Tone
- DTMF and Dial Pulse CO Line Compatible
- DTMF Signal Time (80/160 ms)
- Dual FCC Registration
- External Page Interface\*
- Flexible Button Assignment
- Flexible Intercom Numbering
- Flexible Line Ringing Assignment
  - Immediate
  - Delay 1
  - Delay 2
- Group Paging
- Handsfree Intercom Path (Non-Blocking)
- Least Cost Routing
- Live System Programming from any DKT/EKT
- Memory Protection
- Message Waiting Indication
- Music-on-Hold Interface\*
- Night Ringing Answer Code
- Non-blocking Talk Paths
- Outgoing Call Restriction
- Pooled CO Lines
- Power Failure Transfer
- Privacy/Non-privacy
- Relay Service\*
- Station Hunting
- System Programming through Station
- System Speed Dial
- Tandem CO Line Connections
- Tenant Service
- Toll Restriction
- Toll Restriction Override by System Speed Dial
- Transfer Privacy
- Traveling Class of Service
- Unlimited Handsfree Intercom Paths
- Unrestricted Call Transfer over Intercom
- Voice Mail Integration
  - Automated Attendant
  - Call Forward to Voice Mailbox
  - Feature Integration
  - Message Waiting Indication
  - Voice Mail Control via Digital/Electronic Station
  - Voice Mail Identification Codes
- Voice or Tone Signaling
  - Tone First
  - Voice First

## OPTIONAL

---

- Alarm Sensor (DK16 only)\*
- Alternate Background Music Interface\*
- Amplified Conference Interface (DK16 only)\*
- Data Switching\*
- Direct Inward System Access
- Door Lock Control\*
- Door Phones
- External Amplified Speaker
- Modem Pooling\*
- Night Ringing Over External Page\*
  - Night Pickup Code
- Night Ringing Over Selected Page Zones (DK16 only)\*
- Off-premises Station\*
- Page Zones (DK16 only)\*
- Printer Sharing\*
- Relay Service (Expansion Unit-DK16 only)\*
  - External Page/Door Lock Relay\*
  - Night/Hold Relay\*
- Remote Administration and Maintenance\*
- Reserve Power\*
- Station Message Detail Recording\*
- Standard Telephone Interface

\*May require customer-supplied peripherals; see the detailed feature descriptions.

Table N  
DK8 & DK16 SYSTEM FEATURES

STRATA DK8 & DK16  
GENERAL DESCRIPTION  
MARCH 1993

FEATURE	DIGITAL TELEPHONE	ELECTRONIC TELEPHONE (DK16 only)	STANDARD TELEPHONE	STANDARD FEATURE	OPTIONAL FEATURE
Account Code Button	✓	✓			
Add-on Module (2000-series DKT only)	✓			✓	
All Call Voice Page	✓				✓
Automatic Busy Redial	✓	✓	✓	✓	
Automatic Call Back	✓	✓			✓
Automatic Hold/Park Recall	✓	✓	✓	✓	
Automatic Line Selection	✓	✓	✓	✓	
BGM with Station Control*	✓	✓		✓	
Busy Override (receive):	✓	✓		✓	
■ Over Handset/Headset (2000-series DKT only)	✓			✓	
Busy Override (send)	✓			✓	
Call Forward	✓		✓	✓	
■ All Calls	✓	✓	✓	✓	
■ Busy	✓	✓	✓	✓	
■ No Answer	✓	✓	✓	✓	
■ Busy/No Answer	✓	✓	✓	✓	
■ Fixed	✓	✓	✓	✓	
Call Park	✓	✓		✓	
Call Pickup	✓	✓	✓	✓	
Call Transfer with Camp-on	✓	✓	✓	✓	
Centrex/PBX Compatible	✓	✓	✓	✓	
CO/Centrex/PBX Feature Buttons	✓	✓	✓	✓	
Conferencing	✓	✓		✓	
Continuous DTMF Tones (2000-series DKT only)	✓	✓	✓	✓	
Data Button*	✓			✓	
Data Release Button*	✓				✓
Direct Station Selection Buttons	✓	✓			✓
Direct Station Selection Feature Console (DK16 Only)	✓	✓		✓	
DISA Security Code Revision	✓	✓		✓	
Distinctive LED Indications	✓	✓		✓	
Dual Color LEDs	✓			✓	
Distinctive Station Ringing	✓	✓		✓	
Distinctive Ringing (CO vs. Station Ringing)	✓	✓		✓	
Do Not Disturb	✓	✓	✓	✓	
Do Not Disturb Override	✓	✓		✓	
DP/DTMF Mode Change	✓	✓	✓	✓	
Exclusive Hold	✓	✓		✓	
Executive Override	✓	✓		✓	
Feature Prompting Soft Keys	✓	✓	✓	✓	
Flash Button	✓			✓	
Handsfree Answerback	✓	✓	✓	✓	
Handset/Headset Volume Control	✓	✓		✓	
Hearing Aid Compatible	✓	✓		✓	

Table O  
DK8 & DK16 STATION FEATURES

STRATA DK8 & DK16  
 GENERAL DESCRIPTION  
 MARCH 1993

FEATURE	DIGITAL TELEPHONE	ELECTRONIC TELEPHONE (DK16 Only)	STANDARD TELEPHONE	STANDARD FEATURE	OPTIONAL FEATURE
Liquid Crystal Display	✓	✓			✓
Loud Ringing Bell	✓	✓			✓
Message Waiting/Indication	✓	✓		✓	
Microphone Control Button	✓	✓		✓	
Microphone Sensitivity Control	✓	✓		✓	
Modem Button*	✓				✓
Modular Handset and Line Cords	✓	✓			
Modular Headset Interface	✓	✓			✓
Off-hook Call Announce	✓	✓			✓
On-hook Dialing	✓	✓		✓	
Off-premise Station			✓		✓
Pooled Line Buttons	✓	✓		✓	
Privacy Button	✓	✓		✓	
Privacy Release Button	✓	✓		✓	
Privacy Override	✓	✓		✓	
Private CO Lines	✓	✓	✓	✓	
Push-button Dialing	✓	✓		✓	
Release Button	✓	✓		✓	
Remote Retrieval of Held Calls	✓	✓	✓	✓	
Repeat Last Number Dialed	✓	✓	✓	✓	
Ringling Line Preference	✓	✓		✓	
Saved Number Redial	✓	✓		✓	
Speed Dial Buttons	✓	✓		✓	
Speed Dialing (With Codes)	✓	✓	✓	✓	
Timed Reminder	✓	✓		✓	
Toll Restriction Override Revision	✓	✓		✓	
User Programmable Feature Buttons	✓	✓		✓	
Verified Account Code Revision	✓	✓		✓	

\*Customer-supplied optional equipment may be required.

Table O (continued)  
 DK8 & DK16 STATION FEATURES

GLOSSARY

<b>ADM</b>	Add-on Module.	<b>LED</b>	Light emitting diode—busy lamp indication.
<b>BPS</b>	Bits per second—baud rate.	<b>LSI</b>	Large scale integration.
<b>CO</b>	Central office.	<b>MDF</b>	Main distribution frame.
<b>CODECS</b>	Coder/decoder semiconductor.	<b>MDFB</b>	Door phone unit.
<b>DDCB</b>	Door phone/lock control unit that connects to designated digital telephone circuits.	<b>OCA</b>	Off-hook Call Announce.
<b>DISA</b>	Direct Inward System Access.	<b>PBX</b>	Private branch exchange.
<b>DK</b>	Digital key.	<b>PCB</b>	Printed circuit board.
<b>DSS</b>	Direct Station Selection.	<b>PCM</b>	Pulse code modulation.
<b>DTMF</b>	Dual-tone Multi-frequency.	<b>PCOU</b>	DK16 four circuit CO Line Interface Unit that can be installed in the Expansion Key Service Unit.
<b>EOCU</b>	DK16 Off-hook Call Announce (OCA) subassembly—optional PCB upgrade to PEKU or PESU for OCA.	<b>PDIU-DI2</b>	Integrated data interface unit that can be attached to digital telephones.
<b>FCC</b>	Federal Communications Commission.	<b>PDIU-DS</b>	Stand-alone data interface unit that can be connected to a digital telephone circuit.
<b>HESB</b>	External speaker unit—speaker box with built-in amplifier.	<b>PDKU</b>	DK16 eight circuit Digital Telephone Interface unit that can be installed in the Expansion Key Service Unit.
<b>HHEU</b>	A subassembly to upgrade a digital or electronic telephone with a headset and/or Loud Ringing Bell interface.	<b>PEKU</b>	DK16 eight circuit Electronic Telephone Interface Unit that can be installed in the Expansion Key Service Unit.
<b>IMDU</b>	DK16 Remote maintenance modem subassembly that can be installed on the PIOUS or PIOUS.	<b>PESU</b>	DK16 combination Standard/Electronic Telephone Interface Unit that has two standard telephone circuits and four electronic telephone circuits. Can be installed in the Expansion Key Service Unit.
<b>KCDU</b>	DK16 CO Line/Digital Telephone Interface Unit installed in the Expansion Key Service Unit that provides two loop start CO line circuits and four digital telephone circuits.	<b>PIOU</b>	DK16 option Interface Unit that can be installed in the Expansion Key Service Unit.
<b>KPSU16</b>	DK16 factory installed power supply	<b>PIOUS</b>	DK16 option Interface Unit that can be installed in the Expansion Key Service Unit.
<b>KSTU</b>	DK16 optional four circuit Standard telephone Interface Unit that can be installed in the Base Key Service Unit.	<b>PSTU</b>	DK16 eight circuit Standard Telephone Interface Unit that can be installed in the Expansion Key Service Unit.
<b>KSU</b>	Key service unit.		
<b>K4RCU</b>	DK16 4-circuit subassembly for Auto Busy Redial and DTMF devices.		
<b>LCD</b>	Liquid crystal display.		

STRATA DK8 & DK16  
GENERAL DESCRIPTION  
MARCH 1993

- QCDU** DK8 optional CO Line/Digital Telephone Interface Unit installed in the KSU to provide one loop start CO line circuit and two digital telephone circuit.
- QPSU8** DK8 factory-installed power supply.
- QRCU** DK8 optional three circuit PCB for Auto Busy Redial and DTMF devices.
- QSMU** DK8 optional SMDR/TTY Interface Unit.
- QSNU** DK8 standard two-circuit conference interface.
- QSTU** DK8 optional two-circuit standard telephone interface unit.
- RAM** Random access memory.
- ROM** Read only memory.
- SMDR** Station Message Detail Record
- TTY** The 3-pair modular jack interface on the QSMU (DK8), PIOUS (DK16) and PIOUS (DK16) PCB used to connect a local maintenance/programming terminal or remote maintenance modem.

# **Strata**<sup>®</sup> DK8 & DK16

## **INSTALLATION**

Chapter One	— Introduction	Section 100-816-201
Chapter Two	— Site Requirements	Section 100-816-202
Chapter Three	— System Configuration	Section 100-816-203
Chapter Four	— DK8 KSU and PCB Installation	Section 100-816-204
Chapter Five	— DK16 KSU and PCB Installation	Section 100-816-205
Chapter Six	— Station Apparatus Installation	Section 100-816-206
Chapter Seven	— Peripheral Installation	Section 100-816-207
Chapter Eight	— Wiring Diagrams	Section 100-816-208

TABLE OF CONTENTS

PARAGRAPH	SUBJECT	PAGE
1	PURPOSE .....	1-1
2	ORGANIZATION .....	1-1
3	REFERENCE DOCUMENTATION .....	1-1
3.10	General Description .....	1-1
3.20	Programming .....	1-1
3.30	User Guides .....	1-1
3.40	Fault Finding Procedures .....	1-1
3.50	Remote Maintenance and Administration .....	1-1
4	SYSTEM MNEMONICS/TERMS .....	1-1
4.10	Use of Notes, Important Notes, Cautions, and Warnings .....	1-5

# ***Strata***<sup>®</sup> *DK8 & DK16*

## **INSTALLATION**

### **CHAPTER ONE INTRODUCTION**



## 1 PURPOSE

**1.00** The purpose of this section is to provide detailed step-by-step instructions for installing the STRATA DK8 and STRATA DK16 systems.

**1.01** This chapter provides an overview of the entire installation section, and includes a list of reference documentation that supports the installed system; a list of system mnemonics is also provided.

## 2 ORGANIZATION

**2.00** This manual is organized in modular chapters for easy removal and replacement of updated materials. The chapters are as follows:

- Chapter One - Introduction
- Chapter Two - Site Requirements
- Chapter Three - System Configuration
- Chapter Four - STRATA DK8 KSU and PCB Installation
- Chapter Five - STRATA DK16 KSU and PCB Installation
- Chapter Six - Station Apparatus Installation
- Chapter Seven - Peripherals Installation
- Chapter Eight - System Wiring and Main Distribution Frame Arrangements

## 3 REFERENCE DOCUMENTATION

**3.00** The STRATA DK8 and DK16 digital key systems are supported by the following complement of reference documentation:

**3.10 General Description:** An overview of the STRATA DK8 and DK16 systems and their features.

**3.20 Programming:** Detailed step-by-step instructions on how to enter data in the System Record sheets, and how to program the system from the completed System Record Sheets. LCD responses are included to provide clear guidance for the programmer.

**3.30 User Guides:** Detailed step-by-step guides on how to operate digital telephones, electronic

telephones, standard telephones, direct station selection consoles, add-on modules and data interface units.

**3.40 Fault Finding Procedures:** Hardware troubleshooting and diagnostic information presented in flowchart form.

**3.50 Remote Maintenance and Administration:** Programming and maintenance procedures specially adapted for remote maintenance and administration terminal use. Detailed, step-by-step instructions are provided, complete with the terminal responses.

## 4 SYSTEM MNEMONICS/TERMS

**4.00** Mnemonics are used to identify the system's hardware, operation, and features. The following alphabetical listing describes the mnemonics used in this manual.

**ADM:** Add-on Module—A telephone upgrade that provides 20 Direct Station Selection (DSS) buttons with busy LED indication on STRATA DK16 and 10 DSS buttons plus 8 speed dial buttons (one for every station), one night transfer and one all call page button on STRATA DK8. Can be installed on any or all 2000-series Digital Telephones in the system. Attaches to the telephone and uses the same port assigned to the telephone. ADM buttons are fixed and cannot be changed in system programming.

**BPS:** Bits Per Second—Unit of measure that refers to the transmission speed (baud rate) of electronic signals. It is used when describing data interface unit and modem operation.

**CO:** Central Office—The facility which houses switching equipment that provides telephone service (CO lines, Centrex lines, etc.) for the immediate geographical area.

**CO Line:** A term used to define the STRATA hardware circuit that connects to the Central Office network line pair. Each CO line is assigned a CO line number in system software.

INSTALLATION-INTRODUCTION  
SECTION 100-813-201  
MARCH 1993

**CODECs:** Coder/Decoders—Semiconductors that allow the system to process analog-to-digital and digital-to-analog conversions.

**DDCB:** Digital Door Phone/Lock Control Unit—A peripheral hardware unit that can be connected to designated digital telephone circuits/ports. The DDCB has three interfaces, two of which are dedicated to door phones (MDFB), and one that can be connected to a MDFB or a door lock.

**DISA:** Direct Inward System Access—A feature available for CO lines that allows an outside party to access a STRATA system's internal stations or outgoing CO lines without going through an operator or automated attendant. An optional security code and/or account codes may be set to prevent unauthorized access to outgoing CO lines for through system calling.

**DK:** Digital Key.

**DKSU8:** Key Service Unit (STRATA DK8 only)—The standard key service unit which includes the system's motherboard, power supply, two CO line circuits, four digital telephone circuits, relay service, and interface for Music-on-hold (MOH)/Background Music (BGM) and External Page.

**DKSUB16:** Base Key Service Unit (STRATA DK16 only)—The standard key service unit which includes the system's motherboard, power supply, four CO line circuits, eight digital telephone circuits, relay service, and interface for Music-on-hold (MOH)/Background Music (BGM) and External Page.

**DKSUE16:** Expansion Key Service Unit (STRATA DK16 only)—The optional key service unit which has four universal slots that can support CO line, station, and external option printed circuit boards that are compatible with the larger STRATA DK systems (DK24/DK56/DK96).

**DSS:** Direct Station Selection Console (STRATA DK16 only)—A console designed to facilitate the processing of a heavy load of incoming calls.

There are two types of DSS consoles, the DDSS console and the HDSS console. The chief difference between them is that the DDSS console can be connected to designated digital telephone circuits, while the HDSS console can only be connected to designated electronic telephone circuits.

**DTMF:** Dual-tone Multi-frequency—Push-button dialing.

**DVSU:** Off-hook Call Announce Upgrade—A subassembly that allows a digital telephone to receive Off-hook Call Announce.

**EOCU:** Off-hook Call Announce Upgrade (STRATA DK16 only)—An optional subassembly to the Electronic Telephone Interface Unit PCB (PEKU) or Standard/Electronic Telephone Interface Unit (PESU) that provides support for electronic telephones that must receive Off-hook Call Announce. Electronic telephones that must receive Off-hook Call Announce must also have an HVSU2 subassembly or the combined HVSL/HVSI subassemblies.

**FCC:** Federal Communication Commission—The telecommunication industry's federal regulatory agency. All Toshiba hardware is FCC listed or approved.

**HESB:** External Speaker Box—A speaker/amplifier that can be configured with the system and telephones to provide a variety of functions.

**HESC-65A:** A cable that connects an HHEU-equipped digital telephone or electronic telephone to an HESB for a Loud Ringing Bell.

**HHEU:** Loud Ringing Bell/Headset Jack Interface Upgrade—A small subassembly for use inside a digital telephone or a 6500-series electronic telephone that allows a speaker (HESB) and/or a headset to be installed with the station.

**HVSU2:** Off-hook Call Announce Upgrade—A subassembly that enables an electronic telephone to receive Off-hook Call Announce.

- IMDU:** Remote Maintenance Modem Interface Unit (STRATA DK16 only)—A subassembly installed on a PIOU or PIOUS PCB in the optional DK16 Expansion Key Service Unit that allows the system to be connected with a remote maintenance/administration terminal.
- KCDU:** CO Line/Digital Telephone Interface Unit (STRATA DK16 only)—Optional printed circuit board providing two loop start CO line circuits and four digital telephone circuits that can be installed in the Expansion Unit. The digital telephone circuits support the same devices as the PDKU except for the DDSS console.
- KCOU:** CO Line Interface Unit (STRATA DK16 only)—Factory-installed printed circuit board that comes standard with the Base Key Service Unit to provide four loop start CO line circuits. Available as a spare unit for field replacements.
- KFCU:** (STRATA DK16 only) Option feature cartridge that plugs into the Base Unit to provide feature upgrades to DK16.
- KPSU16:** (STRATA DK16 only) Power supply that comes factory-installed in the Base Key Service Unit. This power supply provides power to the entire system, in its standard and expanded configurations. Available as a spare unit for field replacements.
- K4RCU:** (STRATA DK16 only) Optional unit that can be installed in the Base Key Service Unit to provide a 4-circuit Dual-tone Multi-frequency receiver for CO lines and standard telephones. It also provides busy tone detection for Auto Busy Redial.
- KSTU:** Standard Telephone Interface Unit (STRATA DK16 only)—Optional printed circuit board that can be installed in the Base Key Service Unit to provide four standard telephone circuits.
- LCD:** Liquid Crystal Display—Display used for messaging, identification, and status that appears on some digital and electronic telephones.
- LED:** Light Emitting Diode—Status indicators located on printed circuit boards, digital telephones, and electronic telephones.
- LSI:** Large Scale Integration—Related to circuit design technology. STRATA DK8 and STRATA DK16 printed circuit boards use LSI circuit design.
- MDF:** Main Distribution Frame—The wiring frame usually located in a phone closet.
- MDFB:** Door Phone Box—A peripheral two-way speaker box option. Each MDFB connects to a DDCB. A DDCB can support as many as three MDFBs.
- OCA:** Off-hook Call Announce.
- PBX:** Private Branch Exchange—Industry-standard term which refers to a telephone switch, usually on-premises, which serves an individual company, and is connected to a public telephone exchange through the CO.
- PCB:** Printed Circuit Board.
- PCM:** Pulse Code Modulation—A widely used form of digital telephone switching.
- PCOU1:** CO Line Interface Unit (STRATA DK16 only)—A printed circuit board that can be installed in the optional Expansion Key Service Unit to provide the system with four loop start CO lines circuits.
- PCOU2:** (STRATA DK16 only) The PCOU2 is a direct replacement for the PCOU1. Their fit/function is identical; however, for manufacturing reasons, the PCOU1 was phased out in favor of the PCOU2.
- PDIU-DI/PDIU-DI2:** Integrated Data Interface Unit—Replaces the normal digital telephone base to enable the telephone to transmit and receive data between a terminal/personal computer connected to the telephone and data devices connected to other PDIU-DIs, or to modems, printers, and computers connected to

Stand-alone Data Interface Units (PDIU-DSs). The PDIU-DI is also used to provide personal computer access to outside dial-up data services and/or bulletin boards.

**NOTE:**

*The PDIU-DI and the PDIU-DI2 are identical, except that the PDIU-DI attaches to 1000-series Digital Telephones, while the PDIU-DI2 attaches to 2000-series Digital Telephones.*

**PDIU-DS :** Stand-alone Data Interface Unit—Used for modem pooling, printer sharing, and access to a host/mainframe computer.

**PKU1:** Digital Telephone Interface Unit (STRATA DK16 only)—A printed board that can be installed in the optional Expansion Key Service Unit to provide the system with eight digital telephone circuits. In addition to digital telephones, the PKU can support data interface units (Stand-alone and Integrated), a digital DSS console (DDSS), and a digital door phone/lock control unit (DDCB).

**PKU2:** Digital Telephone Interface Unit (STRATA DK16 only)—Provides same function as the PKU1, except that the PKU1 can only support data interface units on Circuits 1 ~ 7, while the PKU2 can support data interface units on Circuits 1 ~ 8.

**PEKU:** Electronic Telephone Interface Unit (STRATA DK16 only)—An optional PCB that provides the system with eight electronic telephone circuits, which can support electronic telephones, a Background Music source, an electronic DSS console (HDSS), and an amplifier for two CO line conference calls.

**PESU:** Standard/Electronic Interface Unit (STRATA DK16 only)—A printed circuit board with two standard telephone circuits and four electronic telephone circuits that can be installed in the optional Expansion Key Service Unit. The electronic telephone circuits can support the same devices as the PEKU, except for the HDSS console. The standard telephone circuits can

support the same single-line devices as the KSTU and the PSTU.

**PFT:** Power Failure Transfer Interface—Dedicated standard telephone interface located on the motherboard in the DKSUB16 (STRATA DK16) or DKSU8 (STRATA DK8) to provide emergency service during a system power failure.

**PIOU:** Option Interface Unit (STRATA DK16 only)—A printed circuit board that can be installed in the optional Expansion Key Service Unit to provide support and/or circuit interface for optional hardware peripherals and upgrades.

**PIOUS:** (STRATA DK16 only) The same as the PIOU, except the PIOUS has one external paging interface zone, while the PIOU has four.

**NOTE:**

*The system cannot support the PIOU and PIOUS simultaneously. Only one or the other can be installed.*

**PORT:** There are two types of ports: physical and logical. A physical port is an actual station circuit location; a logical port is the set of characteristics—features, station intercom number, etc.—assigned to the physical port. Logical ports are mobile. They can be moved from one physical port to another.

**PBTC:** A Toshiba-supplied cable used to connect customer-supplied batteries to the power supply in the DKSUB for emergency reserve power.

**PPTC:** (STRATA DK16 only) A Toshiba-supplied adapter that is used to connect the modular SMDR and/or maintenance ports to the DB-25 connector of a printer, terminal, modem or call accounting machine. The SMDR/Maintenance (TTY) port is located on the optional QSMU PCB (STRATA DK8), or PIOU or PIOUS PCB (STRATA DK16).

**PSTU1:** Standard Telephone Interface Unit (STRATA DK16 only)—A printed circuit board with a built-in ring generator that can be installed in the optional Expansion Key Service Unit to

device interface for eight standard telephones or optional hardware peripherals (voice mail devices, fax machine, Background Music source, etc).

**PSTU2:** Standard Telephone Interface Unit (STRATA DK16 only)—Provides the same function as the PSTU with the addition of a switch to select high or low ringing generator voltage.

**QCDU:** CO Line Digital Telephone Interface Unit (STRATA DK8 only)—Optional printed circuit board providing one loop start CO line circuit and two digital telephone circuits that can be installed in the KSU. A maximum of two QCDUs may be installed in the DK8.

**QCNU:** Conference Unit (STRATA DK8 only)—Standard factory-installed printed circuit board provides two conference circuits that can be installed in the KSU. The PCB allows two simultaneous conferences: four parties for the first, and three parties for the second simultaneous conference.

**QPSU:** (STRATA DK8 only)—Power supply that comes factory-installed in the KSU. This power supply provides power to the entire system. Available as a spare unit for field replacements.

**QRCU:** Optional printed circuit board that can be installed in the KSU to provide a 3-circuit Dual-tone Multi-frequency receiver for DISA CO lines and standard telephones. It also provides busy tone detection for Auto Busy Redial.

**QSMU:** SMDR/TTY Interface Unit (STRATA DK8 only)—Optional printed circuit board which provides either SMDR, or Remote Maintenance Terminal (TTY) or external modem interface. QSMU configuration is selectable in system programming.

**QSTU:** Standard Telephone Interface Unit (STRATA DK8 only)—Optional printed circuit board that can be installed in the KSU to provide two standard telephone circuits.

**RAM:** Random Access Memory—Refers to the type of system memory that holds individual system configuration and feature programming. RAM is read/write memory, and can be easily revised in programming.

**ROM:** Read Only Memory—Refers to the type of system memory that holds static software that comprises the mechanics of the features' functions. ROM is only revised by Toshiba software engineers.

#### 4.10 Use of Notes, Important Notes, Cautions, and Warnings

4.11 Notes call attention to specific items to elaborate, or to refer the reader to other information.

4.12 Important Notes are used when the information is considered to be very important.

4.13 Cautions call attention to the possibility of equipment being damaged if the instructions are not followed closely.

4.14 Warnings are used when the given tasks involved could cause the possibility of personal injury or death to the technician.

# **Strata**<sup>®</sup> DK8 & DK16

## **INSTALLATION**

### **CHAPTER TWO**

### **SITE REQUIREMENTS**

TABLE OF CONTENTS

PARAGRAPH	SUBJECT	PAGE
1	GENERAL .....	2-1
2	INPUT POWER REQUIREMENTS .....	2-1
3	SITE CONSIDERATIONS .....	2-1
3.00	Clearance and Location Requirements .....	2-1
3.10	Electrical/Environmental Requirements and Characteristics .....	2-2
4	GROUNDING REQUIREMENTS .....	2-2
4.10	Third Wire Ground Test .....	2-2
4.20	Alternate or Additional Ground .....	2-4

TABLE LIST

TABLE	TITLE	PAGE
2-A	SUMMARY OF ELECTRICAL/ENVIRONMENTAL CHARACTERISTICS .....	2-3

FIGURE LIST

FIGURE	TITLE	PAGE
2-1	DK8 BASE KEY SERVICE UNIT AND HPFB MINIMUM CLEARANCE REQUIREMENTS .....	2-1
2-2	BASE KEY SERVICE UNIT MINIMUM CLEARANCE REQUIREMENTS .....	2-1
2-3	DK16 COMBINED BASE AND EXPANSION KEY SERVICE UNIT MINIMUM CLEARANCE REQUIREMENTS .....	2-2
2-4	KSU GROUNDING DIAGRAM .....	2-3

## 1 GENERAL

1.00 This chapter defines the installation site requirements necessary to ensure a proper operating environment for the STRATA DK8 and DK16. Also included are grounding requirements.

## 2 INPUT POWER REQUIREMENTS

2.00 The system requires an input power source of 117VAC nominal (85VAC ~ 135VAC), 50/60 Hz, 15 amps. The AC outlet is recommended to be *dedicated* and unswitched, with a solid third wire ground (refer to Paragraph 4). This is to eliminate interference from branch circuit motor noise or the like, and to prevent accidental power-off.

2.01 To avoid accidental power turn-off, it is recommended that an ON/OFF wall switch *not* be used on this dedicated AC circuit.

2.02 An optional Reserve Power Battery and Charger (HPFB) is available for use with the STRATA DK8 to serve as a power failure backup. For the STRATA DK16, a reserve power source (two customer-supplied 12-volt batteries) may be connected to the system to serve as a power failure backup.

## 3 SITE CONSIDERATIONS

### 3.00 Clearance and Location Requirements

3.01 The key service units must be wall mounted. Figure 2-1 shows the minimum clearance requirements for the STRATA DK8 system, and includes the recommended mounting location and clearance requirements for the optional HPFB. Figures 2-2 (Base Key Service Unit) and 2-3 (Base and Expansion Key Service Unit together) show the minimum clearance requirements for the standard

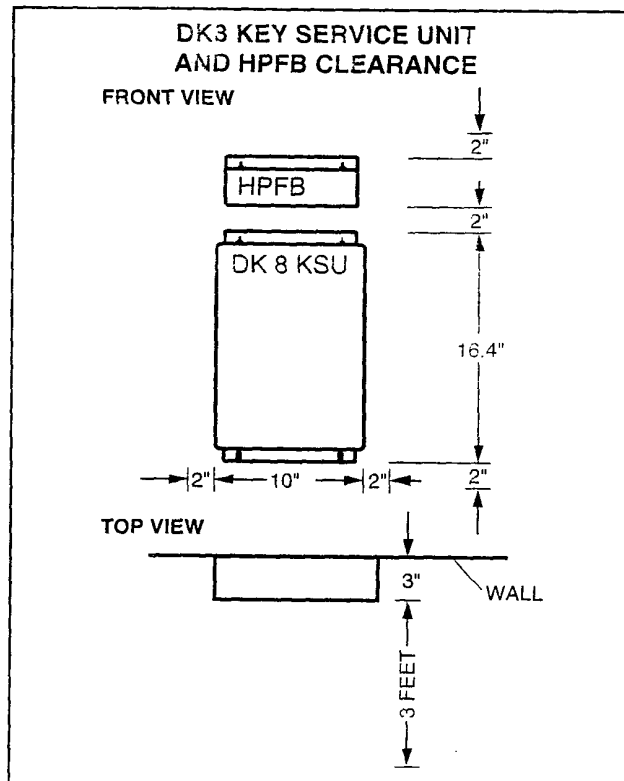


FIGURE 2-1  
DK8 KEY SERVICE UNIT AND HPFB  
MINIMUM CLEARANCE REQUIREMENTS

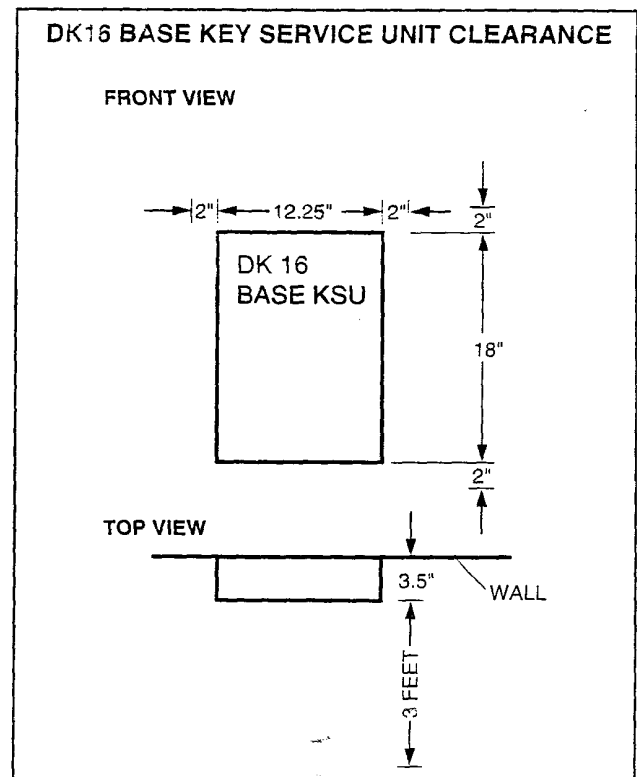
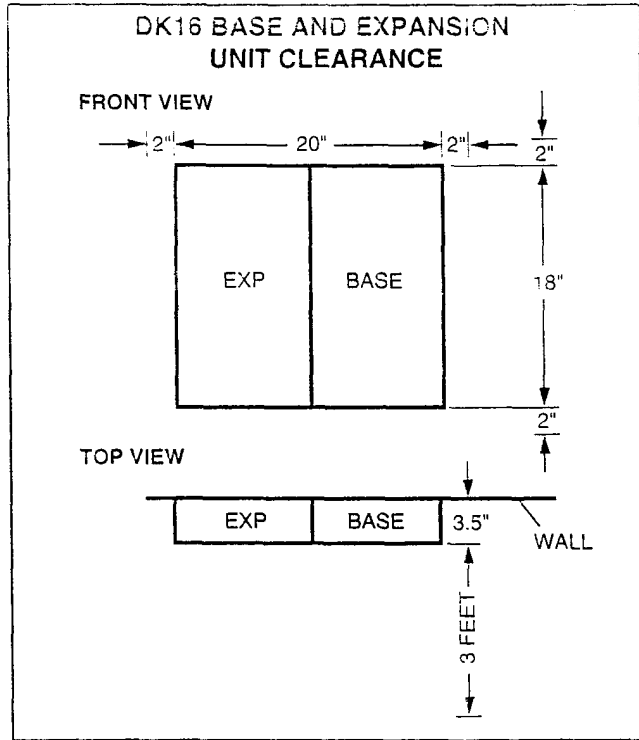


FIGURE 2-2  
DK16 BASE KEY SERVICE UNIT  
MINIMUM CLEARANCE REQUIREMENTS





**FIGURE 2-3**  
**DK16 COMBINED BASE AND**  
**EXPANSION KEY SERVICE UNIT**  
**MINIMUM CLEARANCE REQUIREMENTS**

and optioned STRATA DK16 system. Refer to Chapter 4 for DK16 key service unit wall mounting instructions.

**3.02** The following conditions must be considered when selecting a location for the key service unit(s):

The location **MUST BE**:

- Dry and clean
- Well ventilated
- Well illuminated
- Easily accessible

The location **MUST NOT BE**:

- Subject to extreme heat or cold
- Subject to corrosive fumes, dust, or other airborne contaminants
- Subject to excessive vibration
- Next to television, radio, office automation, or high frequency equipment

**3.03** If reserve power is to be installed for the STRATA DK16, the batteries will require a well-ventilated location close (within nine feet) to the DKSUB16 (the optional Toshiba-supplied battery cable is 9 feet in length). The STRATA DK8 reserve battery (HPFB) should be mounted directly above the DKSU8 as shown in Figure 2-1.

### 3.10 Electrical/Environmental Requirements and Characteristics

**3.11** The electrical/environmental requirements and characteristics for each system are provided in Table 2-A.

## 4 GROUNDING REQUIREMENTS

**4.00** The systems require a solid earth ground for proper operation. Failure to provide ground may lead to confusing trouble symptoms and, in extreme cases, system failure. The AC power cord contains a conductor for the "third wire ground" provided by the commercial power outlet. The third-wire ground should be the only ground necessary for the DK8/DK16; this ground must originate at the buildings main power distribution panel and have a solid connection to earth ground. (Figure 2-4)

### 4.10 Third Wire Ground Test

**4.11** Test the "third wire ground" for continuity by either measuring the resistance between the third prong terminal (earth ground) and a metal cold water pipe (maximum: 1 ohm), or by using a commercially available earth ground indicator. If neither procedure is possible, perform the following earth ground test procedure:

#### **WARNING!**

**Hazardous voltages that may cause death or injury are exposed during the following test. Use great care when working with AC power line voltage.**

- 1) Obtain a suitable voltmeter, and set it for a possible reading of up to 250 VAC.

TABLE 2-A  
SUMMARY OF ELECTRICAL/ENVIRONMENTAL CHARACTERISTICS

GENERAL

<b>Primary power</b> Input AC AC frequency Power	85 ~ 135VAC 50/60 Hz DK8-46 watts maximum. DK16-75 watts maximum								
<b>Environmental specifications</b> Operating temperature Operating humidity Storage temperature	32 ~ 104°F (0 ~ 40°C) 20 ~ 80% relative humidity without condensation -4 ~ 158°F (-20 ~ 70°C)								
<b>Power supply</b> DC voltage output specification	<table style="width: 100%; border: none;"> <tr> <td style="text-align: center; border: none;"><u>DK16</u></td> <td style="text-align: center; border: none;"><u>DK8</u></td> </tr> <tr> <td style="border: none;">-24VDC: (-26.3 ~ -27.8VDC)</td> <td style="border: none;">+24VDC: (+26.3 ~ +27.8VDC)</td> </tr> <tr> <td style="border: none;">+5VDC: (+4.5 ~ +5.5VDC)</td> <td style="border: none;">+5VDC: (+4.5 ~ +5.5VDC)</td> </tr> <tr> <td style="border: none;">-5VDC: (-4.5 ~ -5.5VDC)</td> <td style="border: none;">Note: +5V converter on KSU PCB</td> </tr> </table>	<u>DK16</u>	<u>DK8</u>	-24VDC: (-26.3 ~ -27.8VDC)	+24VDC: (+26.3 ~ +27.8VDC)	+5VDC: (+4.5 ~ +5.5VDC)	+5VDC: (+4.5 ~ +5.5VDC)	-5VDC: (-4.5 ~ -5.5VDC)	Note: +5V converter on KSU PCB
<u>DK16</u>	<u>DK8</u>								
-24VDC: (-26.3 ~ -27.8VDC)	+24VDC: (+26.3 ~ +27.8VDC)								
+5VDC: (+4.5 ~ +5.5VDC)	+5VDC: (+4.5 ~ +5.5VDC)								
-5VDC: (-4.5 ~ -5.5VDC)	Note: +5V converter on KSU PCB								
<b>Battery charger characteristics</b> (DK16 only)	Charger: current limiting Nominal float voltage: 2.275 volts/cell Charge current: 0.7 amps maximum Battery discharge cut-off voltage: 20.5 ± 0.5VDC								
<b>QSTU, KSTU, PSTU or PESU (circuits 1 &amp; 2)</b> Ring voltage Ringing capability	Square wave output with high/low option jumper: Low position, 130 ± 20VDC peak-to-peak (no-load) High position, 190 ± 25VDC peak-to-peak (no-load) Two ringers maximum per circuit, high or low position								

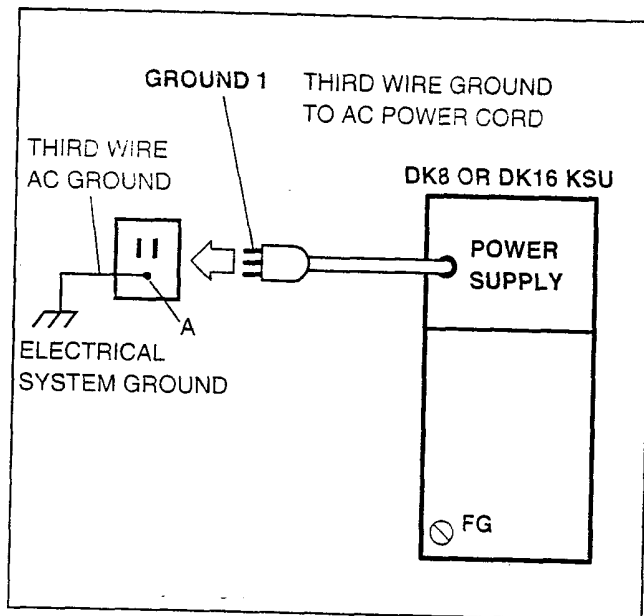


FIGURE 2-4  
KSU GROUNDING DIAGRAM

- 2) Connect the meter probes between the two main AC voltage terminals (white and black wires) on the wall outlet. The reading obtained should be between 100 ~ 120 VAC.
- 3) Move one of the meter probes to the third terminal (green wire ground). Either the same reading or a reading of zero volts should be obtained.
- 4) If the reading is zero volts, leave one probe on the ground terminal and move the other probe to the second voltage terminal.

**CAUTION!**

*If a reading of zero volts is obtained on both voltage terminals (white wire to green wire, black wire to green wire), the outlet is not properly grounded. Omit steps 5 and 6, and proceed directly to step 7.*

INSTALLATION-SITE REQUIREMENTS  
SECTION 100-816-202  
MARCH 1993

- 5) If a reading of zero volts on one terminal, and a reading of 100 ~ 120 VAC on the other terminal is obtained, remove both probes from the outlet.
- 6) Set the meter to the "OHMS/Rx1" scale. Place one probe on the ground terminal, and the other probe on the terminal that produced a reading of zero volts. The reading should be less than 1 ohm.

**CAUTION!**

*If the reading is more than one ohm, then the outlet is not adequately grounded.*

- 7) If the above tests show the outlet is not properly grounded, the condition should be corrected (per Article 250 of the National Electrical Code) by a qualified electrician before the system is connected.

#### 4.20 Alternate or Additional Ground

**4.21** If the "third wire" AC ground can not practically be improved or if extreme motor noise or other disturbance causes system malfunction, or if local area lightning storms exist, a separate direct ground may be warranted.

**4.22** Connect a separate earth ground from a cold water pipe or earth grounding rod directly to the FG screw terminal on the DK8/DK16 power supply. See Figure 4-5 of **Section 100-816-204** (for STRATA DK8) or Figure 5-8 of **Section 100-816-205** (for STRATA DK16).

# **Strata**<sup>®</sup> DK8 & DK16

## **INSTALLATION**

### **CHAPTER THREE**

### **SYSTEM CONFIGURATION**

## 1 INTRODUCTION

**1.00** This chapter offers guidelines and considerations on how to configure a STRATA DK8/DK16 system, which can support a wide variety of stations and peripherals.

## 2 SYSTEM CAPACITY

### 2.00 Total System Capacity

**2.01** The STRATA DK8/DK16 systems have a modular design which allows them to support a number of station and CO line configurations. The main component of each system is the Key Service Unit. The DK8 KSU can have up to 10 stations and four CO lines. The DK16 Base Key Service Unit can have up to 12 stations and four CO lines. An Expansion Key Service Unit can be added to the DK16 to increase the station capacity to 20 and the CO line capacity to eight. Station and CO line configurations are shown in Table 3-A (for DK8) and Table 3-B (for DK16).

### 2.10 The DK8 Key Service Unit

**2.11 Station and CO Lines.** The DK8 Key Service Unit comes standard with four digital telephone circuits (ports) and two CO line circuits (Table 3-C). An optional printed circuit board called the QCDU can be added to the KSU to provide one CO line circuit and two digital telephone circuits. A maximum of two QCDUs may be added to provide a total of four additional digital telephone circuits and two additional CO line circuits. Another optional printed circuit board called the QSTU can be added to the DK8 KSU to provide two standard telephone circuits.

**2.12 Peripherals.** The DK8 Key Service Unit can support a number of peripherals, which are not considered as stations and do not affect the maximum station and CO line capacities. A customer-supplied Music-on-hold source, optional reserve power battery and charger, a customer-supplied emergency standard telephone for system power failure occurrences and an amplifier with speaker for paging and night ringing can all be connected to the Key Service Unit (Table 3-C). A relay contact is also provided to control one of the following

peripherals: Music-on-hold source, night bell, or page amplifier mute control.

### 2.20 The DK16 Base Key Service Unit

**2.21 Station and CO Lines.** The DK16 Base Key Service Unit comes standard with eight digital telephone circuits (ports) and four CO line circuits (Table 3-D). An optional printed circuit board called the KSTU can be added to the unit to provide four standard telephone circuits (ports).

**2.22 Peripherals.** The DK16 Base Key Service Unit can support a number of peripherals, which are not considered as stations and do not affect the maximum station and CO line capacities. A customer-supplied Music-on-hold source, customer-supplied separate background music source, customer-supplied reserve power batteries, a customer-supplied emergency standard telephone for system power failure occurrences and an amplifier with speaker for paging and night ringing can all be connected to the Base Key Service Unit (Table 3-D). A relay contact is also provided to control one of the following peripherals: Music-on-hold source, night bell, or Page Amplifier mute control.

### 2.30 The DK16 Expansion Key Service Unit

**2.31 Station and CO Lines.** The optional DK16 Expansion Key Service Unit has four universal slots which can support a maximum of four CO lines and eight stations. Printed circuit boards (PCBs) that support CO lines and can be installed in the Expansion Unit are the PCOU and KCDU (Table 3-E). PCBs that can support stations and be installed in the Expansion Unit are the PDKU, PEKU, PSTU, PESU, and KCDU.

**2.32 Peripherals.** The Expansion Unit can support either a PIOUS or PIOUS PCB, which both provide, among other features, Station Message Detail Recording (SMDR), an interface for a local programming terminal, and connectors for an internal modem (IMDU) for remote maintenance and administration (Table 3-F). Any device that connects to the PIOUS or PIOUS should not be considered a station and does not affect the system's station capacity.

TABLE 3-A  
DK8 CO LINE/STATION CONFIGURATION GUIDE  
EQUIPMENT

KSU = Key Service Unit (2 CO Lines/4 digital circuits)      CO = Central Office  
QCDU = Optional PCB (1 CO line/2 digital circuits)      DKT = Digital Telephone  
QSTU = Optional PCB (2 standard circuits)      SLT = Standard Telephone

CONFIGURATION CO LINES BY STATION	COs	DKTs	SLTs	EQUIPMENT
2 by 4	2	4		KSU
2 by 6	2	4	2	KSU + QSTU
3 by 6	3	6		KSU + QCDU
3 by 8	3	6	2	KSU + QCDU + QSTU
4 by 8	4	8		KSU + QCDU + QCDU
4 by 10	4	8	2	KSU + QCDU + QCDU + QSTU

TABLE 3-B  
DK16 CO LINE/STATION CONFIGURATION GUIDE (BASE AND EXPANSION UNIT)  
EQUIPMENT

BU = Base Unit (4 CO lines/8 digital circuits)      PSTU = EU option (8 standard circuits)  
KSTU = Base Unit Option (4 standard circuits)      PCOU = EU option (4 CO lines)  
EU = Expansion Unit      CO = Central Office line  
PDKU = EU option (8 digital circuits)      DKT = Digital telephone  
KCDU = EU option (2 CO lines/4 digital circuits)      EKT = Electronic telephone  
PEKU = EU option (8 electronic circuits)      SLT = Standard telephone  
PESU = EU option (2 standard/4 electronic circuits)

CONFIGURATION CO LINES BY STATION	COs	DKTs	EKTs	SLTs	EQUIPMENT
4 by 8	4	8			BU
4 by 12	4	8		4	BU + KSTU
4 by 14	4	8	4	2	BU + EU + PESU
4 by 16	4	8		8	BU + EU + PSTU
4 by 16	4	8	8		BU + EU + PEKU
4 by 16	4	16			BU + EU + PDKU
4 by 18	4	8	4	6	BU + KSTU + PESU
4 by 20	4	8	8	4	BU + KSTU + EU + PEKU
4 by 20	4	16		4	BU + KSTU + EU + PDKU
4 by 20	4	8		12	BU + KSTU + EU + PSTU
6 by 12	6	12			BU + EU + KCDU
6 by 16	6	12		4	BU + KSTU + EU + KCDU
8 by 8	8	8			BU + EU + PCOU
8 by 12	8	8		4	BU + KSTU + EU + PCOU
8 by 14	8	8	4	2	BU + EU + PCOU + PESU
8 by 16	8	8	8		BU + EU + PCOU + PEKU
8 by 16	8	16			BU + EU + PDKU + PCOU
8 by 16	8	16			BU + EU + KCDU + KCDU
8 by 18	8	8	4	6	BU + KSTU + EU + PCOU + PESU
8 by 20	8	16		4	BU + KSTU + EU + KCDU + KCDU
8 by 20	8	8	8	4	BU + KSTU + EU + PCOU + PEKU
8 by 20	8	16		4	BU + KSTU + EU + PCOU + PDKU
8 by 20	8	8		12	BU + KSTU + EU + PCOU + PSTU

TABLE 3-C  
DK8 KEY SERVICE UNIT COMPONENTS

Item	Supports	Connector Type	Standard	Optional
Digital Telephone Circuits (4)	<ul style="list-style-type: none"> <li>Digital Telephones (with or without PDIU-DI2 or ADM)</li> <li>Stand-alone Data Interface Units (PDIU-DS)</li> <li>Door Phone Lock/Control Unit (DDCB)</li> </ul>	25-pair Amphenol	✓	
CO Line Circuits (2)	<ul style="list-style-type: none"> <li>Loop Start CO Lines</li> </ul>	RJ11 Modular	✓	
Power Failure Transfer Interface	<ul style="list-style-type: none"> <li>Standard Telephone (one)*</li> </ul>	RJ11 Modular	✓	
Battery Backup Interface	<ul style="list-style-type: none"> <li>Optional HPFB Battery (one or two per system)</li> </ul>	Proprietary Cable/Connector	Interface	HPFB with cable
Music-On-Hold/BGM Interface	<ul style="list-style-type: none"> <li>Music-on-hold/BGM Source*</li> </ul>	RCA Jack	✓	
600 Ohm page Interface	<ul style="list-style-type: none"> <li>Amplifier/Speaker</li> </ul>	RCA Jack	✓	
CO line CKT (1)/ Digital Telephone CKT (2) (QCDU) (max. 2 QCDU per system)	<ul style="list-style-type: none"> <li>Digital Telephones (with or without PDIU-DI2 or ADM)</li> <li>Stand-alone Data Interface Units (PDIU-DS)</li> </ul>	25-pair Amphenol		✓
	<ul style="list-style-type: none"> <li>Loop Start CO Line</li> </ul>	RJ11 Modular		
Standard Telephone Interface Unit (QSTU) <ul style="list-style-type: none"> <li>2 standard telephone circuits (1 max.) QSTU per system</li> </ul>	<ul style="list-style-type: none"> <li>Standard Telephones*</li> <li>Other Single-line Devices*</li> <li>Fax Machine*</li> <li>Voice Mail Devices</li> <li>Alternate BGM source*</li> </ul>	25-pair Amphenol		✓
DTMF/ABR Tone Receiver (3-Receiver CKT per QRCU)	<ul style="list-style-type: none"> <li>Automatic Busy Redial</li> <li>Standard telephone ports</li> <li>DISA</li> </ul>	Internal		✓
Control Relay	One of the following: <ul style="list-style-type: none"> <li>Night Relay</li> <li>External Page Mute</li> <li>MOH Control Relay</li> </ul>	25-pair Amphenol	✓	
Conference Circuit Interface Unit (QCNU)	<ul style="list-style-type: none"> <li>2 Simultaneous Conferences</li> </ul>	Internal	✓	
SMDR/TTY Interface Unit (QSMU) (Requires PPTC)	<ul style="list-style-type: none"> <li>SMDR Printer*, or</li> <li>Maintenance Terminal* or</li> <li>Modem*</li> </ul>	6-pin Modular (PPTC adaptor)		✓

\*Customer supplied equipment not offered by Toshiba Telecommunication Systems Division.

TABLE 3-D  
DK16 BASE KEY SERVICE UNIT COMPONENTS

Item	Supports	Connector Type	Standard	Optional
Digital Telephone Circuits (8)	<ul style="list-style-type: none"> <li>• Digital Telephones (with or without PDIU-DI2 or ADM)</li> <li>• Stand-alone Data Interface Units (PDIU-DS)</li> <li>• Door Phone Lock/Control Unit (DDCB)</li> <li>• Digital Direct Station Selection Console (DDSS)</li> </ul>	25-pair Amphenol	✓	
CO Line Circuits (4)	Loop Start CO Lines	RJ11 Modular	✓	
Power Failure Transfer Interface	Standard Telephone (one)*	RJ11 Modular	✓	
Battery Backup Interface with built-in charger	Two 12-volt Batteries*	Proprietary Connector/Cable	✓	Cable and Batteries
Music-On-Hold/BGM Interface	Music-on-Hold/BGM source*	RCA Jack	✓	
600 Ohm page Interface	Amplifier/Speaker	RCA Jack	✓	
Standard Telephone* Interface Unit (4-Circuit) (KSTU)	<ul style="list-style-type: none"> <li>• Standard Telephones*</li> <li>• Other Single-line Devices*</li> <li>• Alternate BGM Source*</li> <li>• Fax machine*</li> <li>• Voice mail devices</li> </ul>	25-pair Amphenol		✓
DTMF/ABR Receiver (K4RCU)	<ul style="list-style-type: none"> <li>• Automatic Busy Redial</li> <li>• Standard Telephone Ports</li> <li>• Interprets DTMF Tones</li> <li>• DISA</li> </ul>	Internal		✓
Feature Cartridge	<ul style="list-style-type: none"> <li>• Future Feature Upgrades</li> </ul>	Internal		✓
Control Relay	Choice of one: <ul style="list-style-type: none"> <li>• MOH Source Control</li> <li>• Night Bell Control</li> <li>• BGM Mute Control</li> </ul>	25-pair Amphenol	✓	

\* Customer supplied equipment not offered by Toshiba Telecommunication Systems Division.



TABLE 3-E  
DK16 EXPANSION KEY SERVICE UNIT PCBs

PCB	Circuits per PCB	Interfaces	Connector
PDKU	8 digital telephone circuits	<ul style="list-style-type: none"> <li>• Digital telephones with or without PDIU-DI2 or ADM</li> <li>• DDSS console</li> <li>• PDIU-DSs</li> <li>• DDCB</li> </ul>	25-pair amphenol
PEKU	8 electronic telephone circuits	<ul style="list-style-type: none"> <li>• Electronic telephones</li> <li>• HDSS console</li> <li>• BGM source</li> <li>• EOCU PCB for OCA</li> </ul>	25-pair amphenol
PSTU	8 standard telephone circuits	<ul style="list-style-type: none"> <li>• Standard telephones</li> <li>• Voice mail ports</li> <li>• Background music source</li> <li>• Off-premises stations</li> <li>• Other similar devices</li> </ul>	25-pair amphenol
PESU	2 standard telephone/ 4 electronic telephone circuits (standard/electronic telephone ports)	Standard: same as PSTU Electronic: same as PEKU except PESU does not support HDSS console	25-pair amphenol
PCCU	4 CO line circuits (lines)	<ul style="list-style-type: none"> <li>• Central Office loop start lines</li> </ul>	RJ14C modular
KCDU	2 CO line circuits/ 4 digital telephone circuits	<ul style="list-style-type: none"> <li>• Central Office loop start lines</li> <li>• DKT circuits same as PDKU, except no DDSS</li> </ul>	RJ14C Modular (CO Line circuits) 25-pair amphenol (digital telephone circuits)
PIOU, PIOUS	See Table 3-D	See Table 3-D	25-pair amphenol (PIOU) Spring clip terminal (PIOUS)

### 3 STATION CONSIDERATIONS

**3.00** For configuration purposes, a station can be considered as any device which is connected to a dedicated telephone circuit. Although the words "telephone" and "station" are often used synonymously and interchangeably in STRATA DK8/DK16 documentation, devices other than telephones—such as Stand-alone Data Interface units (PDIU-DSs)—should also be considered as stations when configuring a system, because they require a dedicated telephone circuit. A station apparatus overview is shown in Table 3-G (for STRATA DK8) and Table 3-H (for STRATA DK16).

#### 3.10 Telephone Circuit (Port) Types

**3.11** There are three types of telephone circuits to which stations can be connected: digital telephone circuits, electronic telephone circuits, and standard telephone circuits. All three types of circuits are available with the STRATA DK16. The STRATA DK8 does not support electronic telephone circuits.

#### 3.20 Digital Telephone Circuit Connections

**3.21** The STRATA DK8 Key Service Unit provides four digital telephone circuits. The QCDU PCB provides two.

TABLE 3-F  
PIOU/PIOUS INTERFACE OPTION (DK16 ONLY)

Expansion Unit Interface Options	PIOU	PIOUS
Zone Page Interface (unamplified, 4 zones)	X	
Night Transfer or Music-on-Hold Control Relay	X	X
Door Lock or External Amplifier Control Relay	X	X
Alarm Sensor	X	X
SMDR output (RS-232/6-wire modular connector)	X	X
Maintenance Port for a Local ASCII Terminal or External Modem (RS-232/6-wire modular connector)	X	X
Remote Maintenance Modem (IMDU subassembly, no external connector)	X	X

NOTE: X = the option is provided

TABLE 3-G  
STRATA DK8 STATION APPARATUS OVERVIEW

Station	Type and Number of Circuits Required	PCB or Interface	KSU Capacity	KSU and Optional PCB Combined Capacity
Digital Telephone DKT with or without ADM or PDIUDI	Digital, one for each DKT	KSU (Circuits 1 ~ 4) QCDU (Circuits 1 ~ 2)	4	8
Stand-alone Data Interface Unit (PDIU-DS)	Digital, one for each PDIU-DS	KSU (Circuits 1 ~ 4) QCDU (Circuits 1 ~ 2)	4	8
Digital Door Phone/Lock Control Unit (DDCB)	Digital, one for each DDCB	KSU Port 02 Port 03	2	2
Single-wire pair devices: • Standard Telephone • Voice Mail Device • Facsimile Machine • Modem • Dictation Equipment	Standard, one for each device (voice mail devices may require more than one circuit)	QSTU (Circuits 1 ~ 2)	—	2
Alternate Background Music Source*	Standard port for the source	QSTU (Circuit 2) Port 19	1	1

\* May require interface transformer, see Section 100-816-207.

TABLE 3-H  
STRATA DK16 STATION APPARATUS OVERVIEW

Station	Type and Number of Circuits Required	PCB or Interface	Base Unit Capacity	Base and Expansion Unit Combined Capacity
Digital Telephone (DKT with or without ADM or PDIU-DI)	Digital, one for each DKT	Base Unit (Circuits 1~8) PDKU2 (Circuits 1~8) KCDU (Circuits 1~4)	8	16
Stand-alone Data Interface Unit (PDIU-DS)	Digital, one for each PDIU-DS	Base Unit (Circuits 1~8) PDKU2 (Circuits 1~8) KCDU (Circuits 1~4)	8	16
Digital Direct Station Selection Console (DDSS)	Digital, one for each DDSS	Base Unit (Circuit 8) PDKU (Circuit 8)	1	2
Digital Door Phone/Lock Control Unit (DDCB)	Digital, one for each DDCB	Base Unit (Circuit 5) PDKU (Circuit 1) or first KCDU (Circuit 1)	1	2
Electronic Telephone (EKT)	Electronic, one for each EKT	PEKU (Circuits 1~8) PESU (Circuit 5~8)	0	8
Electronic Direct Station Selection Console (HDSS)	Electronic, two for the HDSS	PEKU (Circuits 7 and 8)	0	1
Conference Amplifier	Electronic, two for the amplifier	PEKU (Circuits 6 and 7) PESU (Circuits 6 and 7)	0	1
Single-wire-pair Devices: • Standard Telephone • Voice Mail Device • Facsimile Machine • Modem • Dictation Equipment	Standard, one for each device (voice mail devices may require more than one circuit)	KSTU (Circuits 1~4) PSTU (Circuits 1~8) PESU (Circuits 1~2)	4	12
Alternate Background Music Source	Standard or Electronic, one for the source	KSTU (Circuit 4) PEKU (Circuit 3) PESU (Circuit 8) PSTU (Circuit 4)	1	1

\* May require interface transformer, see Section 100-816-207.

**NOTE:**

*A maximum of two QCDU PCBs may be installed in the STRATA DK8.*

3.22 The STRATA DK16 Base Key Service Unit and the PDKU PCB each provide eight digital telephone circuits. The KCDU PCB provides four.

**NOTE:**

*A maximum of two KCDU PCBs may be installed in the STRATA DK16. If a KCDU is installed, no other type of station PCB can be installed in the STRATA DK16.*

3.23 The following devices can be connected to digital telephone circuits:

- **Digital Telephones (2000- and 1000-series):** Each digital telephone requires one circuit, and each digital telephone circuit can support a digital telephone.
- **Stand-alone Data Interface Units (PDIU-DS):** Each PDIU-DS requires one circuit. Any digital telephone circuit, except for Circuit 8 on a PDKU1 (STRATA DK16), can support a PDIU-DS (see Note 1).

**NOTES:**

1. *There are two versions of the PDKU: PDKU1 and PDKU2. The versions are identical, except that Circuits 1 ~ 8 on the PDKU2 can each support PDIU-DSs/PDIU-DI, while only Circuits 1 ~ 7 on a PDKU1 can support PDIU-DSs or PDIU-DIs. Also, PDIU1 does not support 2000-series digital telephone continuous DTMF tones.*
2. *The Integrated Data Interface Unit (PDIU-DI/PDIU-DI2) and the Add-on Module (ADM) do not require a dedicated circuit. They share a circuit with the telephone.*
3. *Only one option (PDIU-DI2 or ADM) can be installed on a 2000-series digital telephone.*

- **Digital Direct Station Selection Console (DDSS):** (available with STRATA DK16 only) Each DDSS Console requires one circuit. DDSS Consoles can connect only to Circuit 8 in the Base Key Service Unit and Circuit 8 on a PDKU.

The KCDU cannot support a DDSS console.

- **Digital Door Phone/Lock Control Box (DDCB):** Each DDCB requires one circuit. DDCBs can only connect to Circuits 3 and 4 (Ports 02 and 03) in the STRATA DK8 Key Service Unit or Circuit 5 (Port 04) in the STRATA DK16 Base Key Service Unit, and Circuit 1 (Port 12) on either the PDKU or KCDU (STRATA DK16).

### 3.30 Electronic Telephone Circuit Connections (STRATA DK16 Only)

3.31 There are no electronic telephone circuits in the Base Key Service Unit, and none can be added to it. However, either the PEKU PCB, which has eight electronic telephone circuits, or the PESU, which has four electronic telephone circuits, can be installed in the Expansion Key Service Unit. The following devices can be connected to electronic telephone circuits.

- **Electronic Telephones (6500-, 6000-, 3000-, 2000-series):** An electronic telephone can be connected to any electronic telephone circuit. One electronic telephone circuit is required per electronic telephone.
- **Electronic Direct Station Selection Console (HDSS):** The system will support only one HDSS console. The console must be connected to both Circuits 7 and 8 on the PEKU. The PESU will not support an HDSS Console.
- **Alternate Background Music Source:** The system will support an alternate Background Music source which can be heard over digital and electronic telephone speakers and external page speakers. This source can be connected to either Circuit 3 on a PEKU, Circuit 8 on a PESU, or Circuit 4 on a KSTU or PSTU PCB.
- **Conference Amplifier:** An amplifier for two CO line conferencing can be connected to Circuits 6 and 7 (Ports 17 and 18) on a PEKU or PESU.

### 3.40 Standard Telephone Circuit Options

3.41 In addition to supporting standard telephones, each of the standard telephone circuits can support any one of a number of single-wire-pair devices, including voice mail/Auto Attendant devices and modems. The QSTU, which can be installed in the STRATA DK8 Key Service Unit, has two

standard telephone circuits. The KSTU, which can be installed in the STRATA DK16 Base Key Service Unit, has four standard telephone circuits; the PSTU, which can be installed in the DK16 Expansion Key Service Unit, has eight; and the PESU, which can also be installed in the DK16 Expansion Unit, has two (Circuits 1 and 2).

## 4 TELEPHONE UPGRADES

**4.00** Digital and Electronic telephones can be upgraded for a number of features; there are no upgrades for standard telephones. Each of these upgrades shares a circuit with the telephone that it is connected to and is not considered a station.

### 4.10 Digital Telephone Upgrades

**4.11** Digital telephones can be upgraded with the following subassemblies:

- **Integrated Data Interface Unit (PDIU-DI/PDIU-DI2):** A Digital telephone can be upgraded with a PDIU-DI/PDIU-DI2 to provide the telephone with data switching capabilities. 2000-series Digital Telephones use the PDIU-DI2, and 1000-series Digital Telephones use the PDIU-DI. PDIU-DI2 cannot be installed on a telephone if ADM is installed.
- **Add-on Module (ADM):** A 2000-series Digital Telephone can be upgraded with an ADM to provide 20 Direct Station Selection buttons on STRATA DK16, or 10 DSS buttons, 8 speed dial buttons, one night transfer button and one all call page button on STRATA DK8. The 1000-series Digital Telephone models cannot support ADMs. ADM cannot be installed on a telephone if PDIU-DI2 is installed.
- **Off-hook Call Announce Upgrade (DVSU):** A Digital telephone that must receive Off-hook Call Announce must be upgraded with a DVSU.
- **Loud Ringing Bell/Headset Upgrade (HHEU):** A digital telephone can be upgraded with an HHEU to provide a dual interface for the Loud Ringing Bell feature and/or a headset. (Simultaneously with PDIU-DI2 or ADM).

### 4.20 Electronic Telephone Upgrades

**4.21** On STRATA DK16, electronic telephones can be upgraded with the following subassemblies:

- **Off-hook Call Announce Upgrade (HVSU2 or HVSU/HVSI):** An electronic telephone must be upgraded with the HVSU2 subassembly or the combined HVSU/HVSI subassemblies to receive Off-hook Call Announce.

*NOTE:*

*A PEKU or PESU PCB that supports electronic telephones that must receive Off-hook Call Announce must be equipped with an EOCU.*

- **Loud Ringing Bell/Headset Upgrade (HHEU):** An electronic telephone can be upgraded with an HHEU to provide a dual interface for the Loud Ringing Bell feature and a headset simultaneously.

## 5 CONFIGURATION EXAMPLES

**5.00** The following provides an examples of how to configure a STRATA DK8.

### 5.10 Strata DK8 - Example 1 (Small Retail Store)

**5.11 Customer Requirements.** A store needs two CO lines and four digital telephones.

**5.12 Analysis.** The store's system hardware requirements are as follows:

- Two CO line circuits for the CO lines.
- Four digital telephone circuits for the digital telephones.

**5.13 Conclusion.** A standard Key Service Unit would be adequate in this case. The unit's standard four digital telephone circuits and two CO line circuits could easily accommodate the store's needs and allow for future expansion.

### 5.20 Strata DK8 - Example 2 (Home/Office)

**5.21 Customer Requirements.** In addition to three CO lines, a home/office needs five digital telephones (three of which will have PDIU-DIs), a modem, a door phone, one facsimile machine, Music-on-hold and Telephone Set Background Music.

**5.22 Analysis.** The customer's requirements could be broken down as follows:

- 3 CO line circuits for the three CO lines
- 7 digital telephone circuits
  - one for each of the five digital telephones; the PDIU-DIs do not require dedicated circuits.
  - one for a digital door phone/lock control unit to support a door phone
  - one for the PDIU-DS connected to the modem
- 2 standard telephone circuits
  - one for the modem
  - one for the facsimile machine
- A music source for Music-on-hold and Background music can be connected to the Key Service Unit MOH RCA jacks.

**5.23 Conclusion.** Several optional PCBs in addition to the Key Service unit would be needed for the application. Two CO line circuits and four digital telephone circuits would be provided by the KSU. The third CO line circuit, as well as two digital telephone circuits would be provided by an optional QCDU. A second QCDU would be necessary to provide the seventh digital telephone circuit. An optional QSTU would provide the two standard telephone circuits. An optional QRCU would be needed for the Dual-tone Multi-frequency (DTMF) tones generated by the devices (modem and facsimile machine) connected to the standard telephone lines.

**5.30** The following provides an examples of how to configure a STRATA DK16.

#### **5.40 Strata DK16 - Example 1 (Bank)**

**5.41 Customer Requirements.** A bank needs two CO lines and six digital telephones (three of which must be equipped with a PDIU-DI). It also wants to connect a printer to a PDIU-DS.

**5.42 Analysis.** The bank's system hardware requirements are as follows:

- Two CO line circuits for the two CO lines.
- Seven digital telephone circuits. Six for telephones and one for the PDIU-DS. (The PDIU-DIs do not require a dedicated circuit.)

**5.43 Conclusion.** A standard Base Key Service Unit would be adequate in this case. The unit's standard eight digital telephone circuits and four CO line circuits could easily accommodate the bank's needs.

#### **5.50 Strata DK16 - Example 2 (Office/Warehouse)**

**5.51 Customer Requirements.** In addition to five CO lines, a small office-warehouse facility needs 11 digital telephones (three of which will have PDIU-DIs), two PDIU-DSs, a modem, a facsimile machine, conference capability, a door phone, one standard telephone, Music-on-hold, and an amplifier/speaker for paging.

**5.52 Analysis.** The customer's requirements could be broken down as follows:

- 14 digital telephone circuits
  - one for each of the 11 digital telephones; the PDIU-DIs do not require dedicated circuits.
  - one for each of the two PDIU-DSs
  - one for a digital door phone/lock control unit to support a door phone
- 3 standard telephone circuits
  - one for the modem
  - one for the facsimile machine
  - one for the standard telephone
- A music source for Music-on-hold and an amplifier/speaker for paging could both be connected to the Key Service Unit RCA jacks.
- A K4RCU would be needed for the Dual-tone Multi-frequency (DTMF) tones generated by the devices connected to the standard telephone circuits.
- A PCOU would be needed for the fifth CO line.

**5.53 Conclusion.** An Expansion Key Service Unit in addition to the Base Key Service Unit would be needed for this application. The three standard telephone circuits could be contained on the optional KSTU PCB in the Base Unit. However, a PDKU installed in the Expansion Unit would be required for six of the 14 digital telephone circuits. The Expansion Unit would also be needed for the PCOU. The optional K4RCU, along with the music source and the page/amplifier, as noted earlier, could be connected to the Base Unit.

## **6 CONFIGURATION WORKSHEETS**

**6.00** Worksheets are provided in this chapter to help configure the system.

DK3 WORKSHEET 1. STATION AND CO LINE TOTALS

**1. DIGITAL PORTS (CIRCUITS)**

Device	Quantity	x	Ports/Per	=	Ports Used
DDCBs (2 max.)	_____	X	1	=	_____
PDIU-DSs (8 max.)	_____	X	1	=	_____
Digital Telephones (with or without PDIU-DIs or ADMs) (8 max.)	_____	X	1	=	_____
			Total Digital Ports (8 max.)	=	_____

**2. STANDARD PORTS (CIRCUITS)**

Device	Quantity	x	Ports/Per	=	Ports Used
<i>Maximum of 2 items total, including Standard Telephones:</i>					
Standard Telephones	_____	X	1	=	_____
or					
Other Devices:					
-Voice Mail					
-Auto Attendant					
-BGM Source					
-Fax					
-Modem	_____	X	1	=	_____
			Total Standard Ports (2 maximum)	=	_____

**3. CO LINES**

Number of CO lines required? \_\_\_\_\_  
 (Maximum of 4)

## DK8 WORKSHEET 2, KEY SERVICE UNIT AND PCBs

1. From Worksheet 1 enter the number of required ports (circuits) and lines.

Digital Ports: \_\_\_\_\_ (8 max)

Standard Ports: \_\_\_\_\_ (2 max)

CO Lines: \_\_\_\_\_ (4 max)

*NOTE: The maximum number of digital ports is 8, and standard ports is 2. The maximum number of CO lines is four.*

2. Cross off the printed circuit boards (PCBs)—in addition to the standard Base Key Service Unit lines and ports— needed to support the ports and lines entered in Step 1 of this worksheet.

### **KSU Interfaces (built-in)**

2 CO lines, 4 digital ports

### **KSU Optional Unit Station and Line PCBs**

QCDU (1 CO line and  
2 digital ports): \_\_\_\_\_ two max.

QSTU (2 standard ports): \_\_\_\_\_ one max.

3. Refer to Worksheet 3 to determine option and peripheral requirements.



## DK8 WORKSHEET 3, PERIPHERALS AND UPGRADES

### 1. BASE UNIT PERIPHERALS

**Battery Backup Interface:** Yes or No \_\_\_\_\_

One or two HPFB batteries can be connected to a backup battery interface (Standard on DK8) to provide backup battery backup if there is a power failure. (Connecting cable is included. 1-HPFB for .5 ~ 1 hour backup; 2-HPFBs for 1.5 ~ 2 hours backup.)

**QRCU:** Yes or No \_\_\_\_\_

The QRCU is required to interpret Dual-tone Multi-frequency (DTMF) tones from standard telephones, Voice Mail, Auto Attendant, and DISA CO circuits, or if the Auto Busy Redial (ABR) feature is required.

**Music-on-hold/Background Music Source Interface:** Yes or No \_\_\_\_\_

A music source can be connected to this interface (Standard on DK8) to provide Music-on-hold to CO lines and stations on hold, and to provide Background Music to station speakers and external page speakers.

**Power Failure Transfer Interface:** Yes or No \_\_\_\_\_

A standard telephone can be connected to this interface to provide connection to a CO line if there is a power failure. PFT interface is standard on DK8; one customer-supplied standard telephone is required.

**600 ohm page Interface (Standard on DK8):** Yes or No \_\_\_\_\_

This interface connects with customer-supplied speakers and amplifiers for paging (or Toshiba HESB) and Background Music applications.

**QSMU:** Yes or No \_\_\_\_\_

A customer-supplied Station Message Detail Recording (SMDR) printer, or Remote Maintenance Terminal (TTY) or modem.

**PPTC:** Yes or No \_\_\_\_\_

Modular adaptor required for interface to SMDR device or Maintenance Terminal or Modem.

### 2. TELEPHONE UPGRADES (All upgrades share the telephone port and do not require separate ports.)

**Add-on Module (ADM):** Total \_\_\_\_\_

2000-series digital telephones can be equipped with an Add-on Module to provide 10 Direct Station Selection buttons, autodial buttons, all call page, and night transfer (if PDIU-DI2 is installed, ADM cannot be installed).

**DVSU:** Total \_\_\_\_\_

One DVSU is required for each digital telephone that must receive Off-hook Call Announce.

**HESC-65A:** Total \_\_\_\_\_

One HESC-65A modular connecting cable is required to connect the HESB to the HHEU in each telephone requiring the Loud Ringing Bell feature. See HHEU and HESB.

**HHEU:** Total \_\_\_\_\_

One HHEU must be installed in each digital telephone that supports a headset or connects to an HESB for the Loud Ringing Bell feature. See HESC-65A.

**PDIU-DI2:** Total \_\_\_\_\_ for 2000-series Digital Telephones;  
(If ADM is installed, PDIU-DI2 cannot be installed).

**PDIU-DI1:** Total \_\_\_\_\_ for 1000-series Digital Telephones

Digital telephones must be equipped with a PDIU-DI2 or a PDIU-DI1 to transmit and receive voice and data calls.

**DK8 WORKSHEET 3, PERIPHERALS AND UPGRADES (continued)**

**Miscellaneous Peripherals**

**HESB (Amplifier/Speaker):** Total \_\_\_\_\_

1. One HESB and HHEU is required for each digital telephone with the Loud Ringing Bell feature.
2. One HESB is optional to provide single-zone external page connected to the KSU's 600 ohm external page output. (Customer-supplied amplifiers/speakers may be used in place of the HESB.)
3. One HESB is optional to provide a talkback amplifier/page speaker connected to the KSU's 600 ohm external page output. (Customer-supplied amplifiers/speakers may be used in place of the HESB.) Talkback requires MDFB also.

**DDCB/MDFB (Door Phone):** Total DDCBs \_\_\_\_\_ Total MDFBs \_\_\_\_\_

The MDFB plugs into the DDCB to provide a door phone. Each DDCB can support up to three MDFBs; a maximum of two DDCBs and 6 MDFBs can be connected to the system. Each DDCB requires a digital telephone circuit. The MDFB may also be connected to the HESB amplifier/speaker to provide page talkback.

**NOTE:**

*Worksheet 4, System Power Check, is not required for DK8. The DK8 power supply will support any DK8 maximum configuration.*

DK16 WORKSHEET 1, STATION AND CO LINE TOTALS

1. DIGITAL PORTS (CIRCUITS)

Device	Quantity	x	Ports/Per	=	Ports Used
DDSS Consoles (2 max.)	_____	X	1	=	_____
DDCBs (2 max.)	_____	X	1	=	_____
PDIU-DSs (16 max.)	_____	X	1	=	_____
Digital Telephones (with or without PDIU-DIs or ADMs) (16 max.)	_____	X	1	=	_____
				Total Digital Ports (16 max.)	= _____

2. ELECTRONIC PORTS (CIRCUITS)

Device	Quantity	x	Ports/Per	=	Ports Used
HDSS Console (1 max.)	_____	X	2	=	_____
Alternate BGM Source (1 max.)	_____	X	1	=	_____
Conference Amplifier (1 max.)	_____	X	2	=	_____
Electronic Telephones (8 max.)	_____	X	1	=	_____
				Total Electronic Ports (8 max.)	= _____

3. STANDARD PORTS (CIRCUITS)

Device	Quantity	x	Ports/Per	=	Ports Used
<i>Maximum of 12 items total, including Standard Telephones:</i>					
Standard Telephones or	_____	X	1	=	_____
Other Devices:					
-Voice Mail	_____	X	1	=	_____
-Auto Attendant	_____	X	1	=	_____
-Fax	_____	X	1	=	_____
-Modem	_____	X	1	=	_____
-Alternate Background Music (BGM) Source	_____	X	1	=	_____
				Total Standard Ports (12 maximum)	= _____

4. CO LINES

Number of CO lines required? \_\_\_\_\_  
(8 maximum)

**DK16 WORKSHEET 2, KEY SERVICE UNIT AND PCBs**

1. From Worksheet 1 enter the number of required ports (circuits) and lines.

Digital Ports: \_\_\_\_\_  
 Electronic Ports: \_\_\_\_\_  
 Standard Ports: \_\_\_\_\_  
 CO Lines: \_\_\_\_\_

*NOTE: The maximum number of combined digital, electronic, and standard ports is 20. The maximum number of CO lines is eight.*

2. Cross off the printed circuit boards (PCBs)—in addition to the standard Base Key Service Unit lines and ports— needed to support the ports and lines entered in Step 1 of this worksheet.

**Base Unit Interfaces/PCBs**

Base Unit (4 CO lines, 8 digital ports):      X              built-in  
 KSTU (4 standard ports):                      \_\_\_\_\_              one max.

**Expansion Unit Station and line PCBs**

KCDU (2 CO lines and 4 digital ports):	_____	two max.	(KCDU cannot be installed with any other type of station PCB or PCOU PCB)
- or -			
PDKU (8 digital ports):	_____	one max.	
- or -			
PEKU (8 electronic ports):	_____	one max.	
- or -			
PSTU (8 standard ports):	_____	one max.	
- or -			
PESU (2 standard ports and 4 electronic ports):	_____	one max.	
PCOU (4 CO lines):	_____	one max.	(PCOU can be installed with PDKU, PEKU, PESU, or PSTU, but not with KCDU)

**NOTES:**

1. The Base Unit by can only support up to 12 stations (8 digital and 4 standard) and four CO lines.
2. The Expansion Unit can support up to eight stations and four CO lines.
3. If installing two DDCBs, a PDKU or a KCDU is required to support the second DDCB—no matter what the total number of digital ports.
4. If installing two DDSS Consoles, a PDKU is required to support the second DDSS Console—no matter the total number of digital ports. (KCDU does not support DDSS.)

3. Refer to Worksheet 3 to determine option and peripheral requirements.

4. Refer to Worksheet 4 to determine the amount of power used by the system.

## DK16 WORKSHEET 3, PERIPHERALS AND UPGRADES

### 1. BASE UNIT PERIPHERALS

**Battery Backup Interface:** Yes or No \_\_\_\_\_

Two 12-volt customer-supplied batteries can be connected to this interface to provide backup battery backup if there is a power failure. See PBTC-3M.

**K4RCU:** Yes or No \_\_\_\_\_

The K4RCU is required to interpret Dual-tone Multi-frequency (DTMF) tones from standard telephones, Voice Mail, Auto Attendant, and DISA CO circuits.

**Music-on-hold/Background Music Source Interface:** Yes or No \_\_\_\_\_

A music source can be connected to this interface (Standard on DK16) to provide Music-on-hold to CO lines and stations on hold, and to provide Background Music to station speakers and external page speakers.

**Alternate Background Music Source:** Yes or No \_\_\_\_\_ (see **Worksheet 1**)

**Power Failure Transfer Interface:** Yes or No \_\_\_\_\_

A standard telephone can be connected to this interface to provide connection to a CO line if there is a power failure. PFT interface is standard on DK16; one customer-supplied standard telephone is required.

**PBTC-3M:** Yes or No \_\_\_\_\_

One PBTC-3M cable is required for each system that requires battery backup. See Battery Backup Interface.

**600 ohm page interface (Standard on DK16):** Yes or No \_\_\_\_\_

This interface connects with customer-supplied speakers and amplifiers (or Toshiba HESB) for paging and Background Music applications.

**Night Bell:** Yes or No \_\_\_\_\_

A customer supplied night ringing bell can be installed and controlled by the Base Unit relay control (Standard on DK16).

### 2. EXPANSION UNIT PERIPHERAL PCB

**PIOU or PIOUS:** If yes, which one \_\_\_\_\_

See Table 3-D.

**PPTC:** One or Two \_\_\_\_\_

Modular adaptor, required for PIOU/PIOUS interface to SMDR device or local maintenance terminal.

### 3. TELEPHONE UPGRADES (All upgrades share the telephone port and do not require separate ports.)

**Add-on Module:** Total \_\_\_\_\_

2000-series digital telephones can be equipped with an Add-on Module to provide 20 Direct Station Selection buttons. (If PDIU-DI2 is installed, Add-on Module cannot be installed.)

**DVSU:** Total \_\_\_\_\_

One DVSU is required for each digital telephone that must receive Off-hook Call Announce.

**HESC-65A:** Total \_\_\_\_\_

One HESC-65A modular connecting cable is required to connect the HESB to the HHEU in each telephone requiring the Loud Ringing Bell feature. See HHEU and HESB.

## DK16 WORKSHEET 3, PERIPHERALS AND UPGRADES (continued)

**HHEU:** Total \_\_\_\_\_

One HHEU must be installed in each digital and electronic telephone that supports a headset or connects to an HESB for the Loud Ringing Bell feature. See HESC-65A.

**HVSU2 or Combined HVSU/HVSI:** Total \_\_\_\_\_

Electronic telephones must be equipped with either the HVSU2 assembly or the combined HVSU and HVSI<sup>1</sup> assemblies to receive Off-hook Call Announce. See EOCU under Miscellaneous Peripherals.

**PDIU-DI2:** Total \_\_\_\_\_ for 2000-series Digital Telephones;

**PDIU-D1:** Total \_\_\_\_\_ for 1000-series Digital Telephones

Digital telephones must be equipped with a PDIU-DI2 or a PDIU-D1 to transmit and receive voice and data calls. (If Add-on module is installed, then PDIU-DI2 cannot be installed.)

### Miscellaneous Peripherals

**DPFT:** Yes or No \_\_\_\_\_

The DPFT provides a means to connect eight selected CO lines to standard telephones if there is a power failure. (PSTU must be installed in Expansion Unit)

**EOCU:** Yes or No \_\_\_\_\_

An EOCU must be installed on a PEKU or PESU that is connected to electronic telephones which are equipped to receive Off-hook Call Announce. See HVSU2 and HVSU/HVSI in Telephone Upgrades.

**HESB (Amplifier/Speaker):** Total \_\_\_\_\_

1. One HESB and HHEU is required for each digital and electronic telephone with the Loud Ringing Bell feature.
2. One HESB is optional to provide single-zone external page connected to the Base Unit's 600 ohm external page output. (Customer-supplied amplifiers/speakers may be used in place of the HESB.)
3. One HESB is optional to provide a talkback amplifier/page speaker connected to the Base Unit's 600 ohm external page output. (Customer-supplied amplifiers/speakers may be used in place of the HESB.) Talkback for HESB requires an MDFB.

**MDFB (Door Phone):** Total \_\_\_\_\_

The MDFB plugs into the DDCB to provide a door phone. Each DDCB can support up to three MDFBs; a maximum of two DDCBs can be connected to the system. Each DDCB requires a Digital Telephone circuit. The MDFB may also be connected to the HESB amplifier/speaker to provide page talkback.

DK16 WORKSHEET 4, SYSTEM POWER CHECK

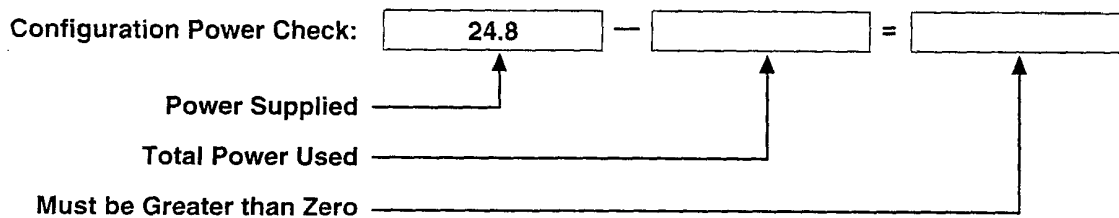
Total Power Used:

Equipment Type:	Equipment Quantity	X	Power Used (Factor)	=	Ports Used
2000- and 1000-series digital telephone	_____	X	(1.0)	=	_____
2000-series electronic telephone	_____	X	(2.0)	=	_____
3000-series electronic telephone	_____	X	(2.5)	=	_____
6000-series electronic telephone	_____	X	(2.0)	=	_____
6005-series electronic telephone	_____	X	(2.0)	=	_____
6500-series electronic telephone	_____	X	(1.0)	=	_____
DDSS/HDSS console*	_____	X	(0.8)	=	_____
PDIU-DI2 and PDIU-DI	_____	X	(0.5)	=	_____
PDIU-DS	_____	X	(0.8)	=	_____
Standard telephone	_____	X	(1.0)	=	_____
Add-on Module	_____	X	(0.4)	=	_____
<b>Total Power Used</b>					<input type="text"/>

\* All series.

Power Criteria:

Power Supplied —  Total Power Used: Must be greater than zero.



# ***Strata***<sup>®</sup> **DK8**

## **INSTALLATION**

### **CHAPTER FOUR DK8 KSU AND PCB INSTALLATION**



TABLE OF CONTENTS

PARAGRAPH	SUBJECT	PAGE
<b>PART I</b>		
	<b>DK8 KSU INSTALLATION .....</b>	<b>4-1</b>
1	GENERAL .....	4-1
2	KEY SERVICE UNIT MOUNTING .....	4-1
2.00	Mounting Surface Considerations .....	4-1
2.10	Mounting Preparation .....	4-1
2.20	Mounting the Key Service Unit .....	4-4
2.30	Installing the Reserve Power Battery and Charger (HPFB) .....	4-4
3	POWER SUPPLY TEST REMOVAL AND REPLACEMENT .....	4-5
3.10	Power Supply Removal .....	4-5
3.20	Power Supply Replacement .....	4-5
4	DK8 POWER FAILURE EMERGENCY TRANSFER OPTION .....	4-5
4.10	DK8 Power Failure Emergency Transfer Installation .....	4-5
4.20	DK8 Power Failure Emergency Transfer Test .....	4-5
<b>PART II</b>		
	<b>DK8 PRINTED CIRCUIT BOARD INSTALLATION .....</b>	<b>4-9</b>
5	GENERAL .....	4-9
6	PCB INSTALLATION CONSIDERATIONS .....	4-9
6.10	KSU Option PCBs .....	4-9
6.20	PCB Option Considerations .....	4-9
6.30	PCB Installation/Power Supply Considerations .....	4-9
7	CO LINE/DIGITAL TELEPHONE INTERFACE UNIT (QCDU) .....	4-9
7.00	General .....	4-9
7.10	QCDU Configuration .....	4-11
7.20	QCDU Installation Procedure .....	4-11
7.30	QCDU Wiring .....	4-12
7.40	QCDU Programming Overview .....	4-13
8	STANDARD TELEPHONE INTERFACE UNIT (QSTU) .....	4-13
8.00	General .....	4-13
8.10	QSTU Configuration .....	4-13
8.20	QSTU Installation Procedure .....	4-13
8.30	QSTU Wiring .....	4-13
8.40	QSTU Programming Overview .....	4-13
9	DTMF RECEIVER/ABR TONE DETECTOR UNIT (QRCU) .....	4-13
9.00	General .....	4-13
9.10	QRCU Configuration .....	4-14
9.20	QRCU Installation Procedure .....	4-14
9.30	QRCU Wiring .....	4-15
9.40	QRCU Programming Overview .....	4-15
10	CONFERENCE CIRCUITS (QCNU) .....	4-15
10.00	General .....	4-15
10.10	QCNU Configuration .....	4-15
10.20	QCNU Installation Procedure .....	4-15
10.30	QCNU Wiring .....	4-15

TABLE OF CONTENTS (CONTINUED)

PARAGRAPH	SUBJECT	PAGE
10.40	QCNU Programming Overview .....	4-15
11	OPTION INTERFACE UNIT (QSMU) .....	4-16
11.00	General .....	4-16
11.10	QSMU Hardware Options .....	4-16
11.20	QSMU Configuration .....	4-16
11.30	QSMU Installation Procedure .....	4-16
11.40	QSMU Wiring .....	4-17
11.50	QSMU Programming Overview .....	4-17
11.60	Device Communication Parameters .....	4-17
12	BUILT-IN CO LINE, DIGITAL TELEPHONE AND OTHER CIRCUITS .....	4-17
12.00	General .....	4-17
12.10	Built-in CO Line Circuits .....	4-17
12.20	Built-In Digital Telephone Circuits .....	4-17
12.30	KSU Motherboard CO Line/Digital Station Circuit Wiring .....	4-17
12.40	Power Failure Telephone Installation .....	4-17
12.50	Music-On-Hold (MOH)/Background Music (BGM) Source Connection .....	4-17
12.60	External Page Output Connection .....	4-17

FIGURE LIST

FIGURE	TITLE	PAGE
4-1	DK8 KEY SERVICE UNIT WALL MOUNT METHOD .....	4-1
4-2	DK8 DIMENSIONS AND SCREW LOCATIONS .....	4-2
4-3	DK8 SIDE VIEW DIMENSION AND PLUG/JACK LOCATIONS .....	4-3
4-4	DK8 CABLING DIAGRAM .....	4-6
4-5	DK8 BASE UNIT JACKS AND CONNECTORS .....	4-7
4-6	DK8 KEY SERVICE UNIT POWER FAILURE TRANSFER (PFT) CIRCUIT DIAGRAM .....	4-8
4-7	DK8 PRINTED CIRCUIT BOARD INSTALLATION .....	4-10
4-8	QCDU CONTROLS AND INTERFACE CONNECTORS .....	4-11
4-9	MODULAR JACK COVER REMOVAL AND STORAGE .....	4-12
4-10	QSTU CONTROLS AND INTERFACE CONNECTORS .....	4-14
4-11	QRCU INTERFACE CONNECTORS .....	4-15
4-12	QCNU INTERFACE CONNECTORS .....	4-16
4-13	QSMU CONTROLS AND INTERFACE CONNECTORS .....	4-16

## PART I. KSU INSTALLATION

### 1 GENERAL

1.00 This chapter provides the instructions necessary to mount the STRATA DK8 Key Service Unit. Instructions are also provided on how to remove and replace the power supply.

### 2 KEY SERVICE UNIT MOUNTING

#### 2.00 Mounting Surface Considerations

2.01 The Key Service Unit (KSU) is designed to be mounted on a wall or other vertical surface. It is recommended to use the method shown in Figure 4-1 (see Note). See Figure 4-2 for DK8 KSU physical dimensions.

**NOTE:**

*Install screws first to the hard board, and then*

*secure the hard board to the wall, making certain that screws are aligned with studs.*

#### 2.10 Mounting Preparation

- 1) Loosen the screws on the front cover of the Key Service Unit, and remove the cover (Figure 4-2).
- 2) Move the SW1 RAM Storage Battery jumper plug strap on the motherboard to the ON position (Figure 4-5).
- 3) If the DK8 is less than one mile from the central office (or PBX), set the CO line PAD switches, SW101 and SW201, to the PAD position to provide a 3db level loss to avoid excessive loudness.
- 4) Install all optional PCBs per Paragraph 5.

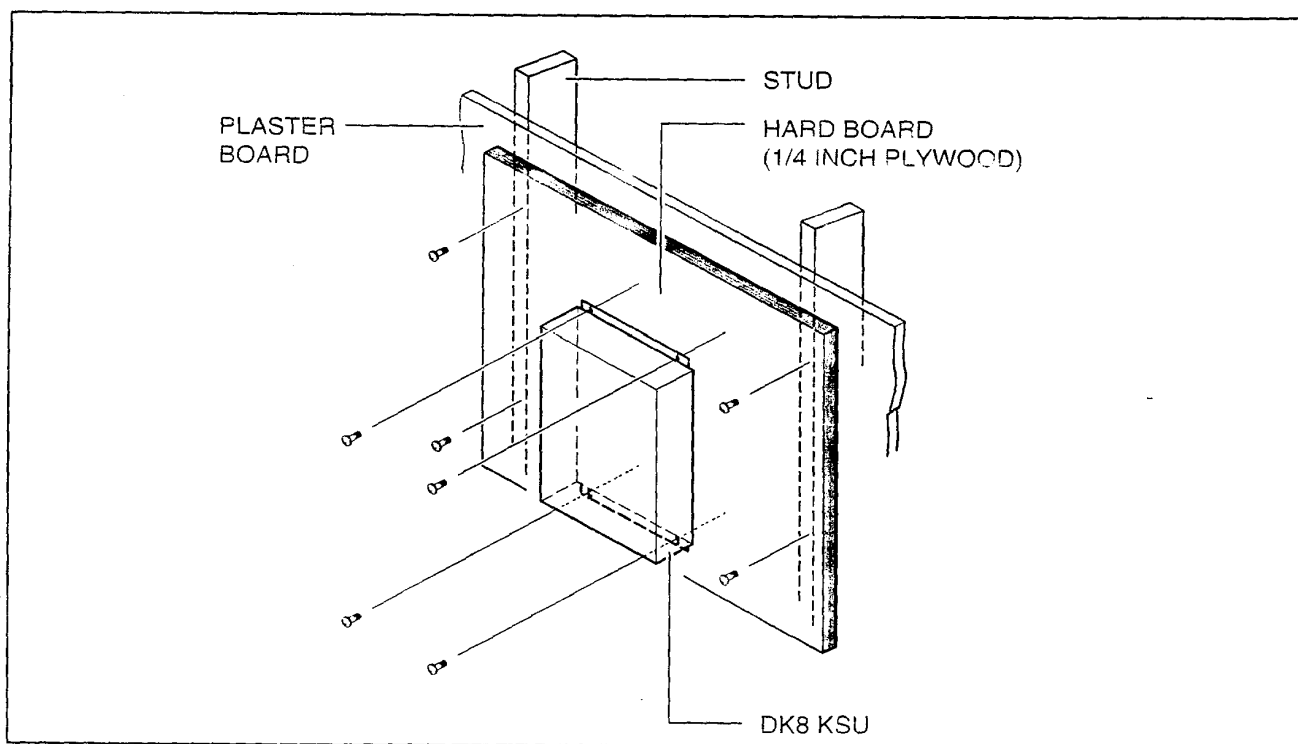


FIGURE 4-1  
DK8 KEY SERVICE UNIT WALL MOUNT METHOD

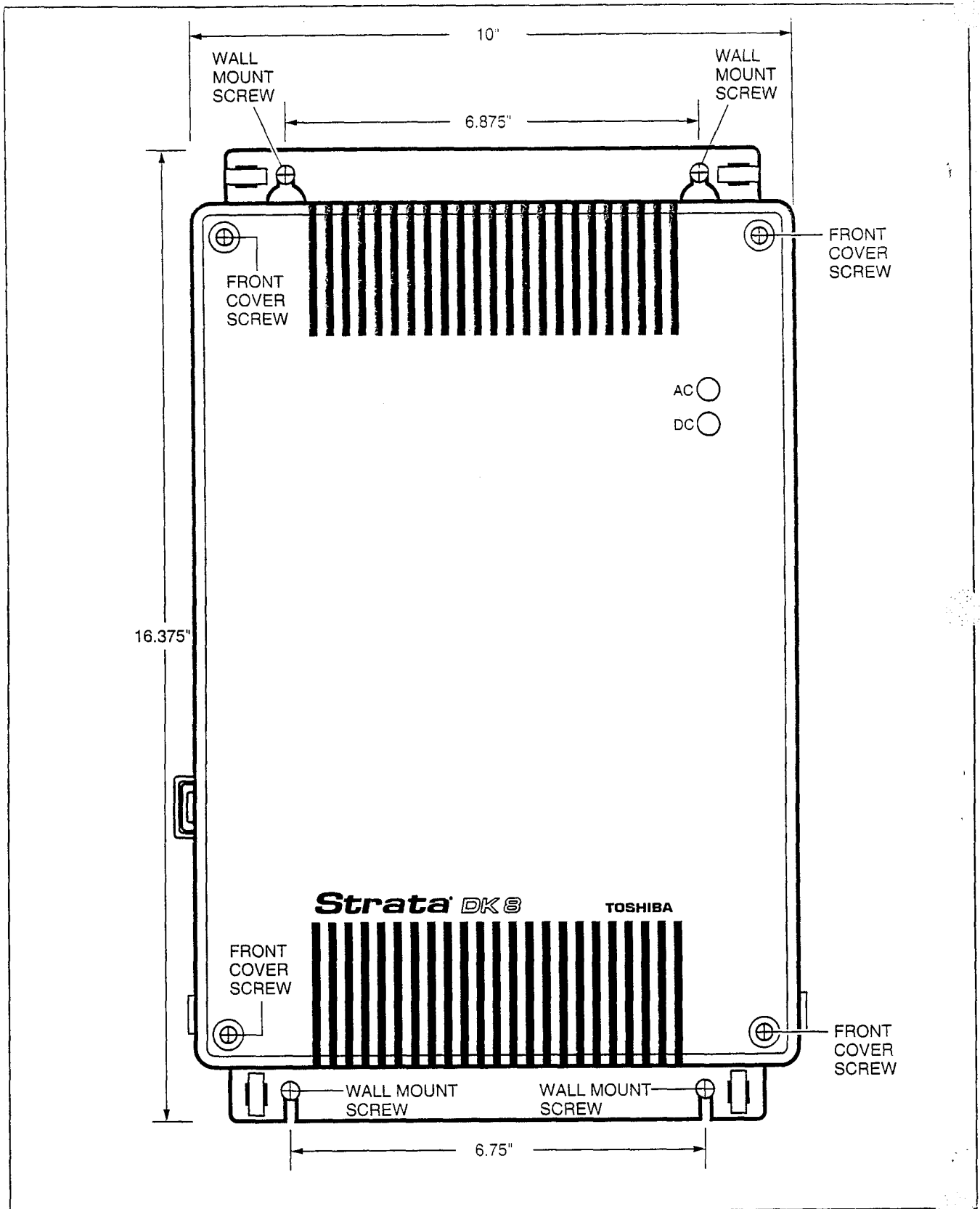


FIGURE 4-2  
DK8 DIMENSIONS AND SCREW LOCATIONS

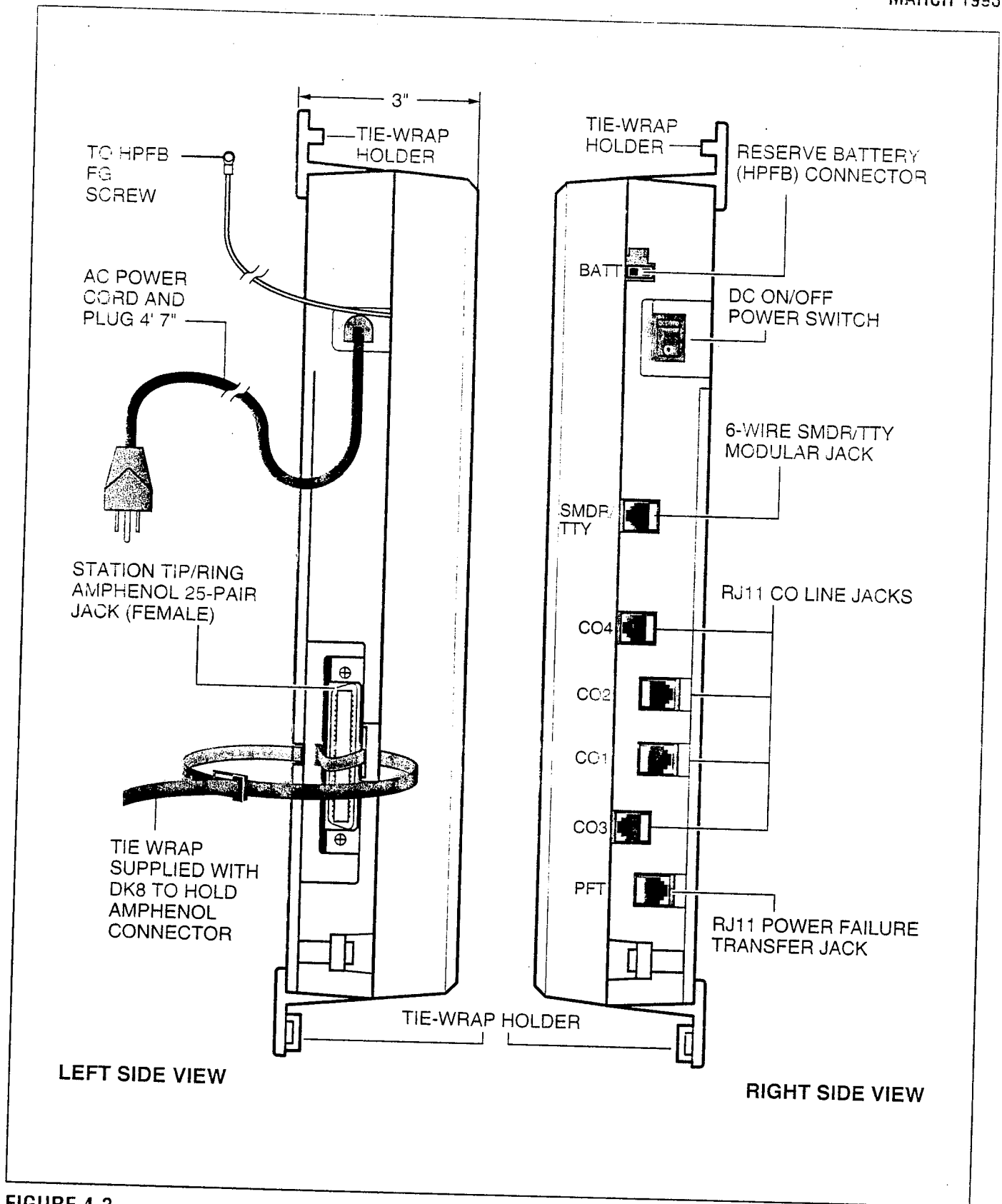


FIGURE 4-3  
DK8 SIDE VIEW DIMENSION AND PLUG/JACK LOCATIONS

## 2.20 Mounting the Key Service Unit

- 1) Make sure the power supply switch is turned OFF.
- 2) Place the Key Service Unit on the desired location on the mounting surface and mark the location of the four screw holes (there is one on each corner). See Figures 4-1 and 4-2.

**NOTE:**

*Make sure the location of the Key Service Unit meets the minimum clearance requirements specified in Figure 2-1 in Chapter 2.*

- 3) Drill holes on these marks.
- 4) Secure screws approximately two thirds of the way into the top two holes on the mounting surface.
- 5) Hang the unit from the top two screws and then secure the screws completely into the mounting surface.
- 6) Finish securing the unit to the mounting surface by completely screwing the bottom two screws into the wall.
- 7) Ground system according to Chapter 2, Paragraph 4.
- 8) Connect applicable wiring (modular CO line cords, 25-pair amphenol connector cable, etc.) to the Key Service Unit. Route the wiring as shown in Figure 4-4, and then fasten wiring to the unit with the tie wraps that come with the Key Service Unit. (See Section 100-816-208, for additional wiring information.)

**NOTE:**

*Figure 4-4 shows cables routed to the right; they may also be routed to the left, depending on the location of the MDF.*

- 9) If the Reserve Power Battery and Charger (HPFB) is going to be installed, refer now to Paragraph 2.30. If not, proceed to Step 10.
- 10) Plug the AC power cable into an outlet and then turn ON the DC power supply switch.
- 11) Reinstall the front cover onto the Key Service Unit.

## 2.30 Installing the Reserve Power Battery and Charger (HPFB) (Figure 4-4)

- 1) Place the HPFU directly above the DK8 KSU.
- 2) Mark the location of the two screw holes, then drill holes.
- 3) Screw the two screws two-thirds into the mounting surface.
- 4) Hang the HPFU on the screws then tighten the screws into the mounting surface.
- 5) Plug the first HPFU connector into BATT connector on the right side of the KSU.
- 6) Connect a ground wire from the HPFB "FG" screw to the DK8 QPSU8 screw labeled "HPFB6." The ground wire can be fed through the opening by the AC power cord (see Figure 4-3).

**NOTE:**

*The DK8 should be plugged into AC power and the DC power switch should be turned on. The HPFU will not start to operate if AC power is not available during the initial installation.*

- 7) The 24V LED on the HPFU should light. If it does not light, press the battery OFF switch with a pencil point or other small-tipped object.
- 8) Dress and tie-wrap the HPFU cables per Figure 4-4.
- 9) To mount a second HPFU, repeat steps 1-4, then plug the second HPFU connector in the first HPFU and connect an FG wire between each HPFB FG screw.
- 10) To test the HPFU, remove the DK8 AC plug from the AC outlet. The DK8 AC LED will go out but the DK8 DC LED remains on, also the system remains in normal working order and the HPFU 24V LED remains on.
- 11) If it is desired to turn off the HPFU (after loss of AC power), use a pencil or other sharp object to press the Battery Off switch.

**CAUTION!**

***Once the HPFU is turned off or unplugged (During AC power loss) it will not operate again until AC power is restored to the DK8 KSU.***

## 3 POWER SUPPLY REMOVAL AND REPLACEMENT

**3.00** The power supply comes factory-installed in the Key Service Unit (Figure 4-5); if necessary, it can be removed and replaced.

### 3.10 Power Supply Removal (Figure 4-5)

- 1) Make sure that the power supply switch is OFF and that the AC power cable is not plugged into an outlet. Confirm that green AC LED is not lit.
- 2) Loosen the screws on the front cover of the Key Service Unit, and remove the cover.
- 3) Unplug HPFB cable from BATT connector of power supply and disconnect the HPFB ground wire (Figure 4-5).
- 4) Unplug the AC cable from the CN1 connector on the power supply (Figure 4-5).
- 5) Remove the FG screw, and disconnect the green third wire ground ring terminal (Figure 4-5).
- 6) Unplug the DC cable from the CN3 connector on the power supply (Figure 4-5).
- 7) Remove the top two, and bottom left corner screws that attach the power supply to the Key Service Unit. Remove power supply.

### 3.20 Power Supply Replacement (Figure 4-5)

- 1) Set the power supply in its proper place in the Key Service Unit (Figure 4-5).
- 2) Secure the power supply to the Key Service Unit with the top two, and bottom left corner screws.
- 3) Install the green third wire ground ring terminal with the FG screw.
- 4) Plug the AC cable into the CN1 connector on the power supply (Figure 4-5).

- 5) Plug the DC cable into the CN3 connector on the power supply (Figure 4-5).
- 6) Plug the AC power cable into an outlet and turn ON the power supply switch.
- 7) Test QPSU8 power supply according to the DK8 Hardware Fault Isolation procedure, Section 100-816-500, Paragraph 6.
- 8) Plug HPFB cable into BATT connector of power supply and reconnect the HPFB ground wire (Figure 4-5).
- 9) Reinstall the cover on the key service unit.

## 4 DK8 POWER FAILURE EMERGENCY TRANSFER OPTION

**4.00** A dedicated standard telephone can be connected to the Power Failure Transfer Interface (PF1) on the Key Service Unit to provide power failure backup. During normal operation, this telephone cannot be used—it does not count as a station; so it does not reduce the system's 10 maximum station capacity. But if there is a power failure, the telephone will automatically be connected to CO line 1. When power is restored, the system will automatically resume with its normal station and CO line assignments, and the dedicated telephone will become inoperative again.

**4.10 DK8 Power Failure Emergency Transfer Installation.** Install the dedicated emergency standard telephone as follows (see Figure 4-6):

- 1) Connect a standard telephone to the PF1 connector in the Base Unit.

**4.20 DK8 Power Failure Emergency Transfer Test.**

- 1) Turn the system power switch off.
- 2) Lift the emergency standard telephone handset, and verify that there is CO dial tone.

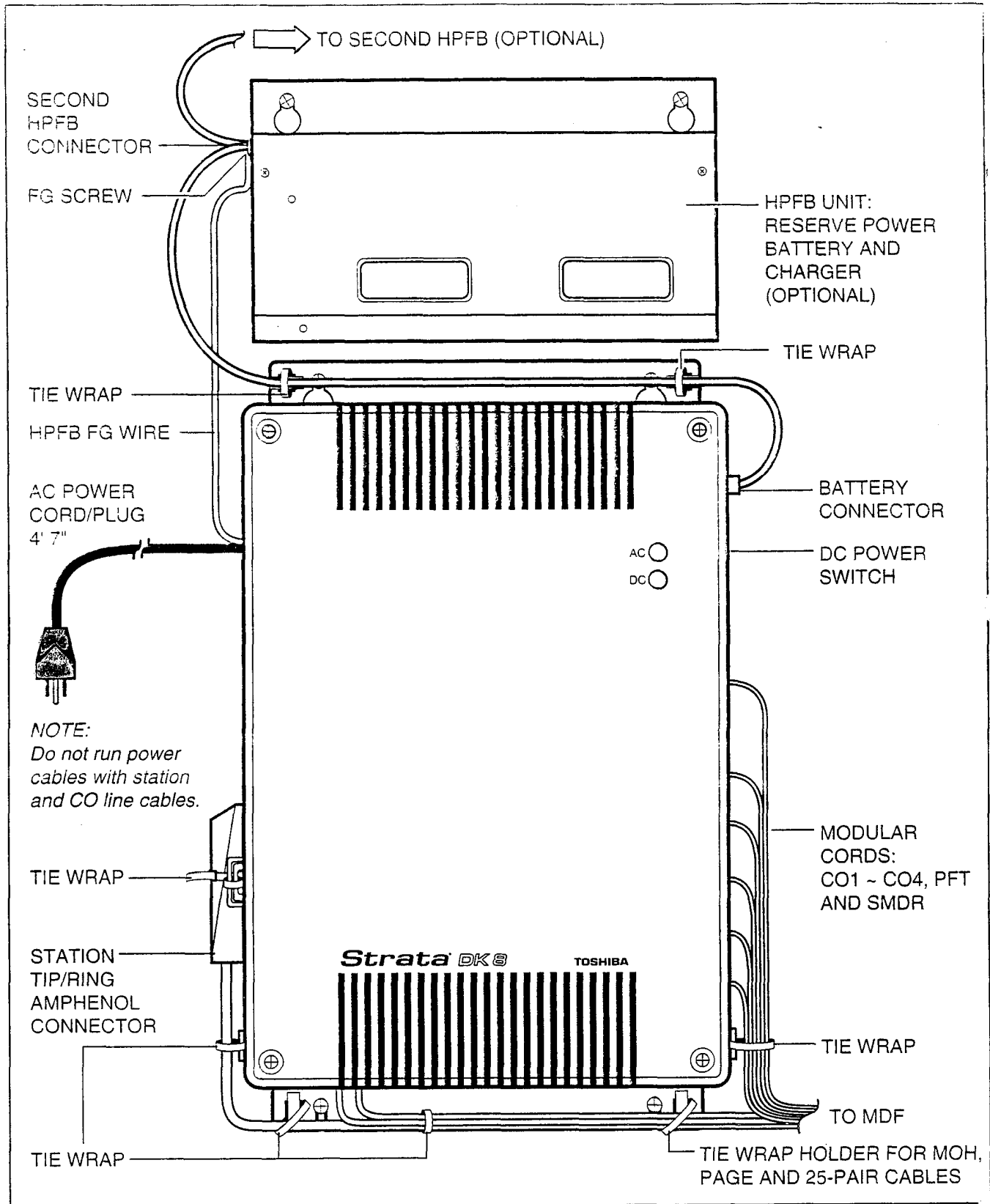
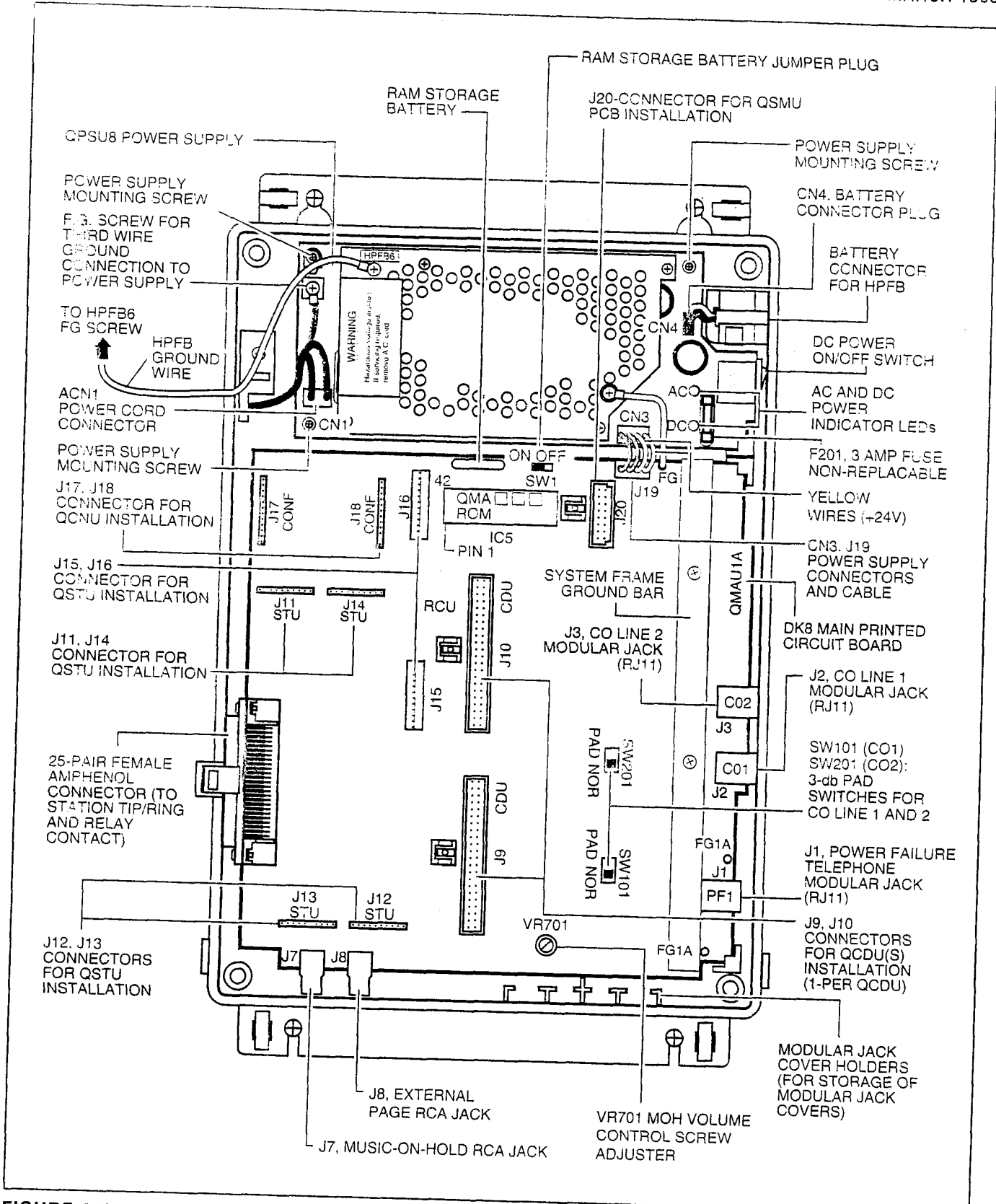
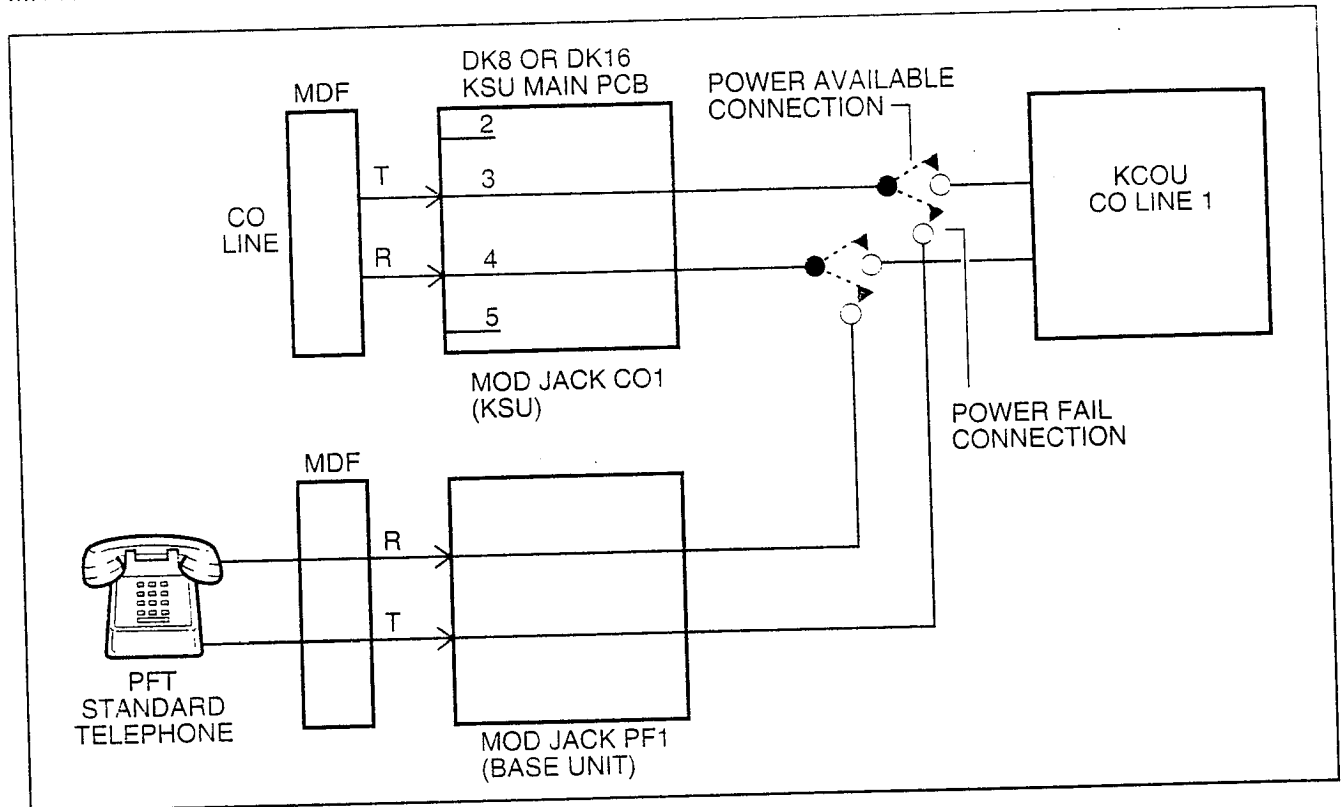


FIGURE 4-4  
 DK8 CABLING DIAGRAM





**FIGURE 4-5  
 DK8 BASE UNIT JACKS AND CONNECTORS**



**FIGURE 4-6**  
**DK8 KEY SERVICE UNIT POWER FAILURE TRANSFER (PFT) CIRCUIT DIAGRAM**

## PART II. PRINTED CIRCUIT BOARD INSTALLATION

### 5 GENERAL

**5.01** This chapter provides procedures for installation of STRATA DK8 system optional printed circuit boards (PCBs) into the Key Service Unit. This includes installation instructions, optional configuration information, and wiring and programming considerations for each PCB.

**5.02** Be sure the ground has been checked. (See **Chapter 2** for grounding.)

### 6 PCB INSTALLATION CONSIDERATIONS

**6.01** The STRATA DK8 KSU comes standard with four digital telephone circuits (ports) and two CO line circuits. These circuits, along with the common control unit, are built into the motherboard.

#### 6.10 KSU Option PCBs

**6.11** The KSU can support up to five optional printed circuit boards (PCBs) (Figure 4-7): it can support a maximum of two QCDUs, each of which provides one CO line circuit and two digital telephone circuits; a QSTU which provides two standard telephone circuits (ports); a QRCU which provides three circuits to receive DTMF tones (required for DISA and devices connected to QSTUs), and three circuits to detect busy tone (required for the ABR feature); and a QSMU which provides a port for either a Station Message Detail Recording (SMDR) device or a maintenance terminal or modem (System Program 10-3, LED 04) selects the function of the port — SMDR or TTY).

**6.12** The KSU does not come from the factory with any option PCBs installed. Each of the option PCBs listed above must be installed in specific locations as described later in this chapter.

**NOTE:**

*QCNU is a standard factory installed piggy-back PCB which provides conference circuits allowing two simultaneous conferences with four of these parties on the first conference*

*call and three parties on the second simultaneous conference.*

#### 6.20 PCB Option Considerations

**6.21** PCBs may be configured for a variety of hardware and software options. Hardware options are defined as either internal (generally related to optional PCB subassemblies) or external (related to connection of peripheral equipment such as background music, voice mail, etc). Hardware and software options for each PCB are identified in the individual PCB installation procedures in this chapter.

**6.22 PCB Hardware Options.** Each PCB must be configured for the applicable hardware options prior to installation of the PCB. Configuration instructions for internal hardware options are provided in the individual PCB installation procedures in this chapter. Configuration instructions for external hardware options are provided in Peripheral Installation, Section **100-816-207**.

**6.23 PCB Software Options.** PCBs are configured for software options through programming, after installation of the PCBs in the KSU. A programming overview for each PCB is provided in the individual PCB installation procedures in this chapter. Refer to the Programming Procedures, Section **100-816-300**, for detailed programming instructions.

#### 6.30 PCB Installation/Power Supply Considerations

**6.31** Whenever removing or installing PCBs it is recommended that the power supply be OFF.

## 7 CO LINE/DIGITAL TELEPHONE INTERFACE UNIT (QCDU)

### 7.00 General

**7.01** The QCDU provides one loop start CO line circuit and two digital telephone circuits. The QCDU digital telephone circuits can support digital telephones, PDIU-D1s/PDIU-D12s or ADMs connected to the telephones and PDIU-DSs. The QCDU does not support a DDSS console or DDCB. A maximum of two QCDU PCBs may be installed in the KSU.

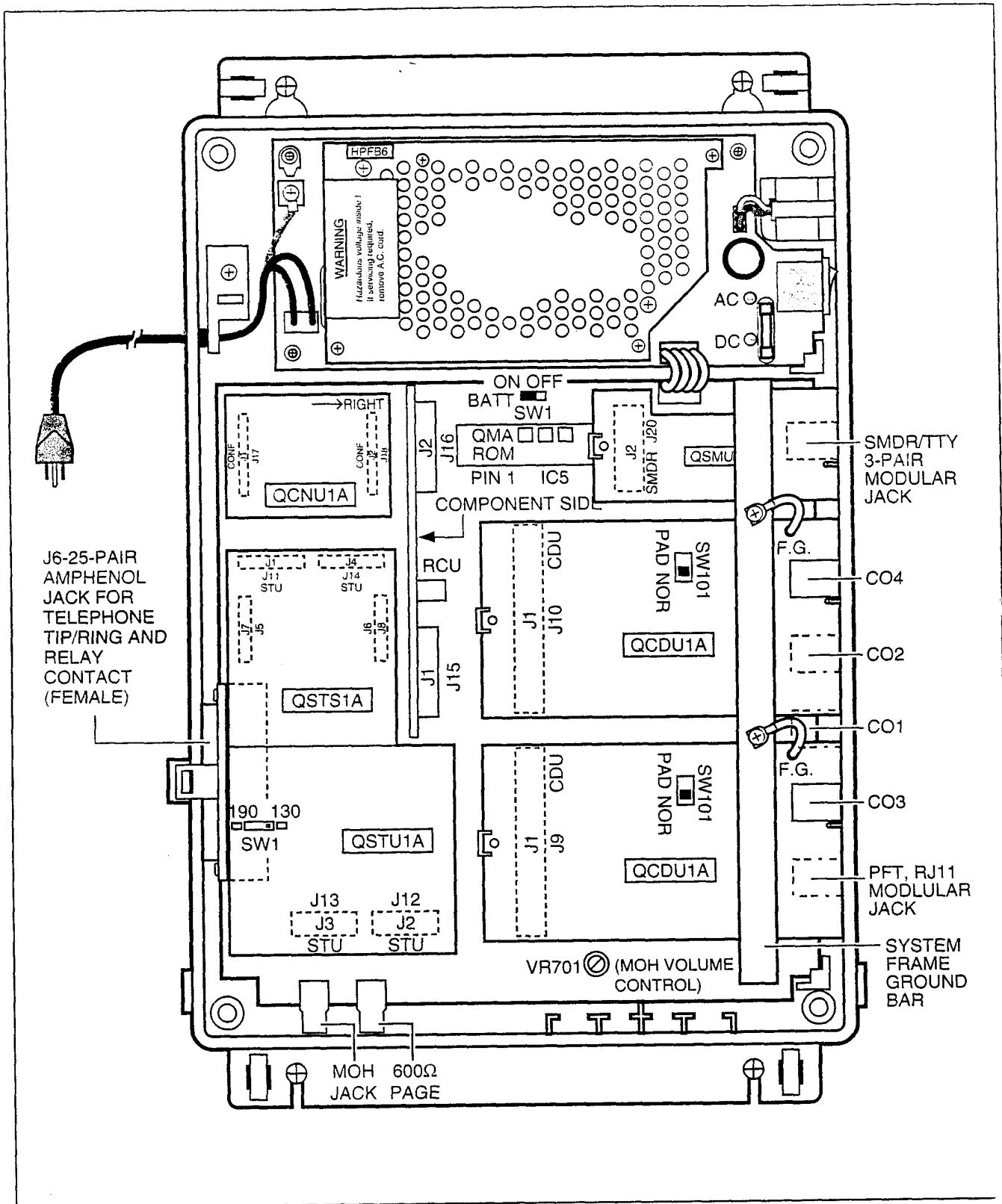
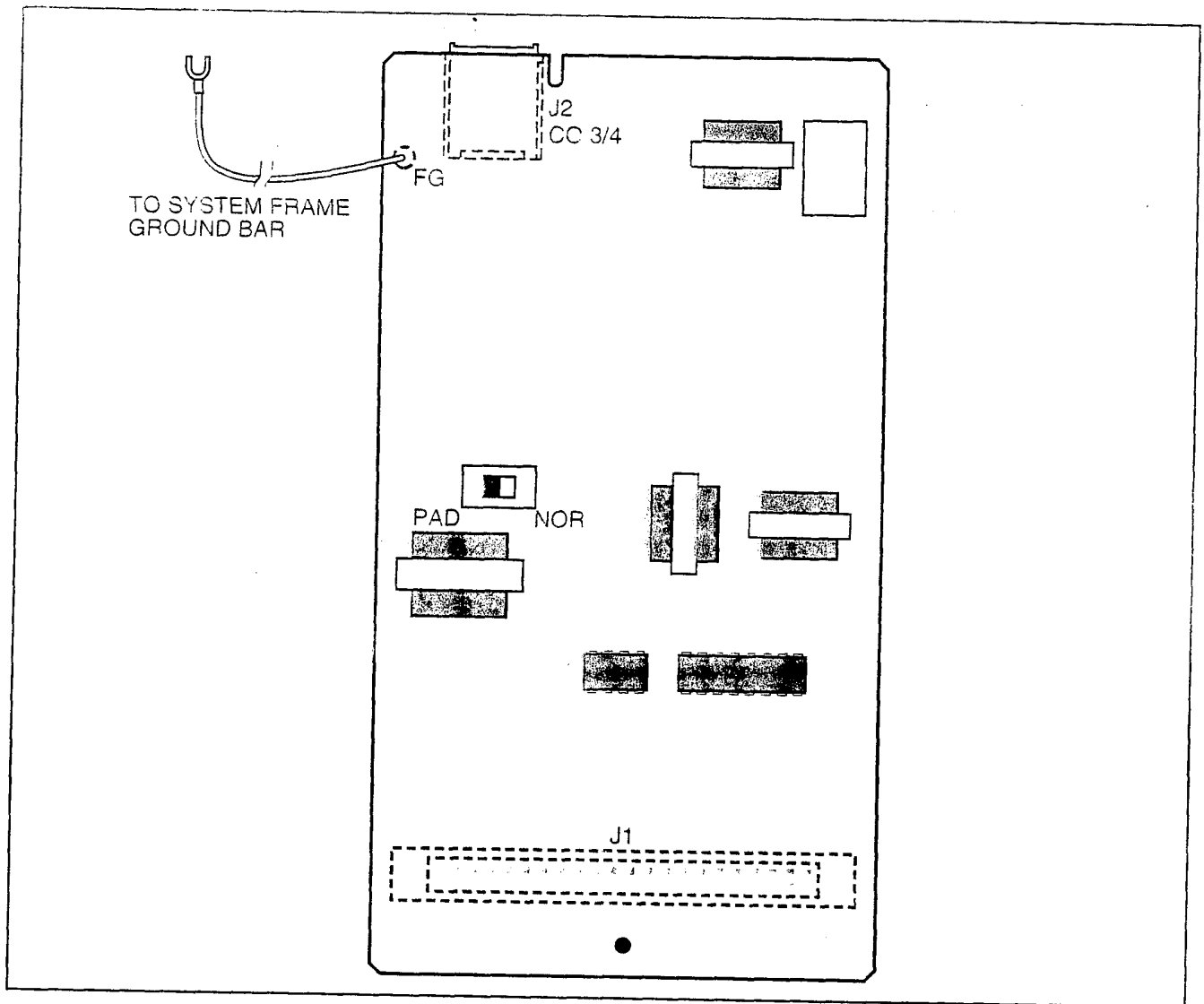


FIGURE 4-7  
 DK8 PRINTED CIRCUIT BOARD INSTALLATION



**FIGURE 4-8**  
**QCDU CONTROLS AND INTERFACE CONNECTORS**

7.02 The QCDU is shown in Figure 4-8.

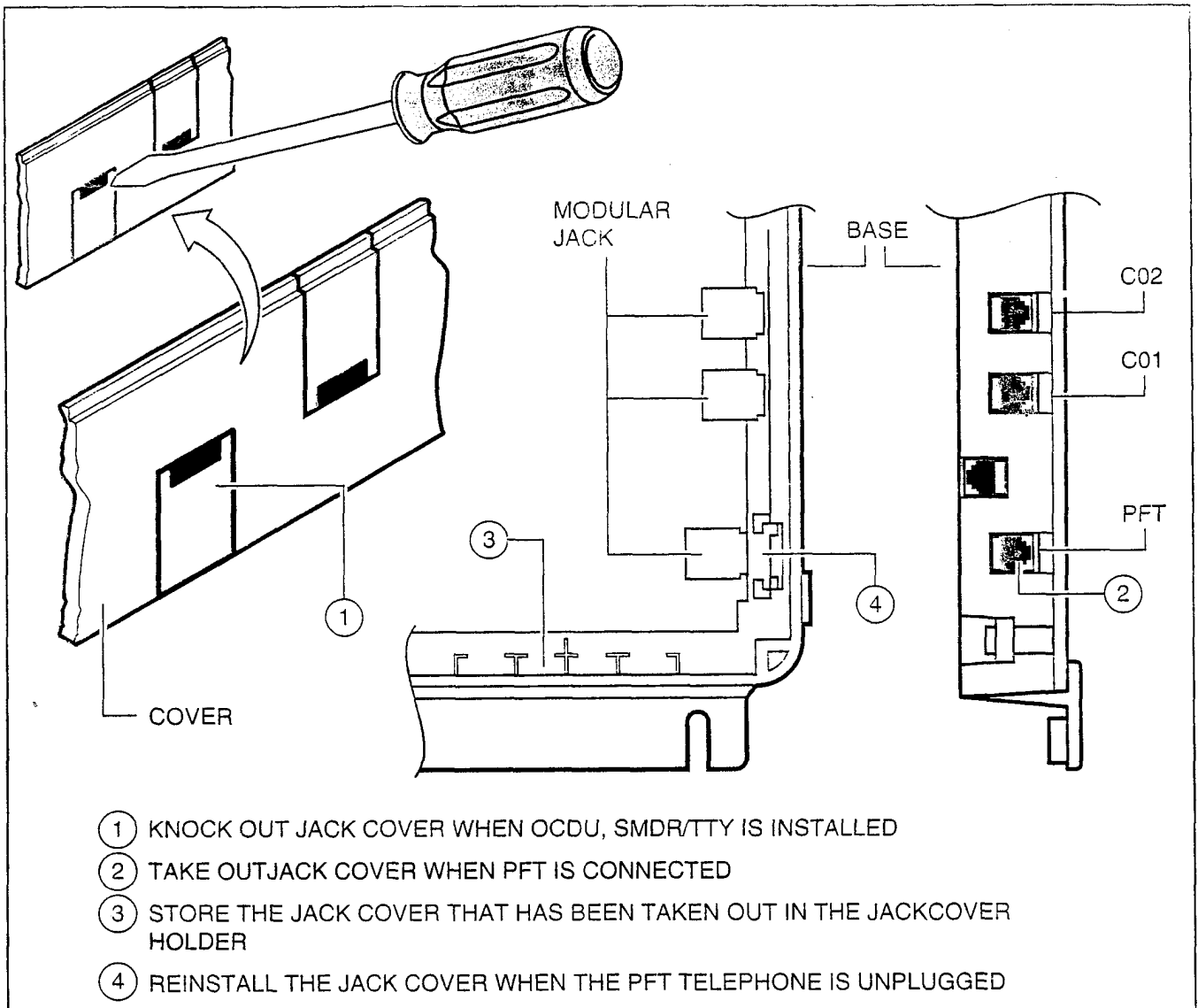
#### 7.10 QCDU Configuration

7.11 The QCDU may have to be configured to control excessive loudness if the system is close to a CO or installed behind a PBX telephone system. It does not have to be configured for anything else. The decibel (db) PAD switch, **SW101** controls the loudness by providing a 3 db signal level drop to, or from, the PBX or CO when set to the PAD position. The switch comes from the factory set at NOR (for normal) meaning no PAD loss.

#### 7.20 QCDU Installation Procedure

7.21 Install the QCDU in accordance with the following steps (Figure 4-7):

- 1) Remove the PCB from its protective packaging.
- 2) If the system is located within one mile of the CO or PBX telephone system, set db **PAD** switch **SW101** to the PAD position.
- 3) Make sure that the power supply switch is OFF.



**FIGURE 4-9**  
**MODULAR JACK COVER REMOVAL AND STORAGE**

- 4) Slide front edge and FG wire of QCDU under the "System Frame Ground Bar", align and insert QCDU connector **J1** into the motherboard connector (**J9** for CO3 first, **J10** for CO4 second), and apply firm, even pressure to ensure proper mating of the connectors. Make sure the edge of the QCDU next to the connector **J1** snaps firmly into the standoffs on the KSU motherboard.
- 5) Connect the Frame Ground (FG) lead from the QCDU to the screw nearest the QCDU located on the system Frame Ground bar.

- 6) Remove the "knock-out" from the KSU cover **CO3** or **CO4** access slot, and store the "knock-out" in the slots provided in the KSU base (Figure 4-9).

### 7.30 QCDU Wiring

**7.31** Refer to the DK8 MDF to CO Line Wiring Diagram in Section 100-816-208 for wiring/interconnecting details.

## 7.40 QCDU Programming Overview

7.41 The following parameters may be specified, through programming, for the QCDU.

### Program 10-1

- Allows/denies two-CO Line Conference and Direct Inward System Access (DISA).

### Program 15

- Auto Release detection; DISA, and other attributes to the CO line.

### Program 16

- Assigns CO line to groups 81 ~ 84, and dial 9 group.

### Program 40

- Assigns stations access to CO line (incoming and outgoing access).

## 8 STANDARD TELEPHONE INTERFACE UNIT (QSTU)

### 8.00 General

8.01 The QSTU provides two standard telephone circuits. The QSTU supports two-wire devices such as standard telephones, Auto Attendant devices, separate BGM source connection, voice mail machines, and facsimile machines.

#### NOTE:

*For the system to recognize the Dual-Tone Multi-Frequency (DTMF) tones generated by standard telephones (or any other device connected to a QSTU port), a QRCU must be installed.*

8.02 The QSTU is shown in Figure 4-10. Note that the QSTS PCB is factory installed on the QSTU.

### 8.10 QSTU Configuration

8.11 The QSTU only has to be configured for the ring generator voltage level, nothing else. Before installing the QSTU in the KSU, set the **SW1** ring generator to 130V P-P or 190V P-P (Figure 4-10). Most standard telephones and two-wire devices require 190; however, some devices may experience ring-trip at 190, and should be set at 130.

### 8.20 QSTU Installation Procedure

8.21 Install the QSTU in accordance with the following steps (Figure 4-7):

- 1) Remove the PCB from its protective packaging.
- 2) Set the ring voltage jumper plug **SW1** to select the appropriate ring generator voltage level, either 130V P-P or 190V P-P.
- 3) Make sure that the power supply switch is OFF.
- 4) Align and insert QSTU connectors **J1**, **J2**, **J3**, and **J4** motherboard connectors **J11**, **J12**, **J13**, and **J14** respectively, and apply firm, even pressure to ensure proper mating of the connectors.

### 8.30 QSTU Wiring

8.31 Refer to DK8 MDF to KSU Amphenol Wiring in Section 100-816-208 for QSTU wiring.

8.32 The QSTU must be connected to a OL13A (or equivalent) type lines for off-premises stations. (300 ohms loop resistance max., including the telephone or other devices DC off hook resistance.)

### 8.40 QSTU Programming Overview

8.41 The following parameters may be specified for the QSTU:

#### Program 31

- Used to configure all QSTU ports connected to voice mail (see Chapter 7 for voice mail installation).

#### Program 10-2

- Used to set standard telephone ringing option and separate BGM assignment.

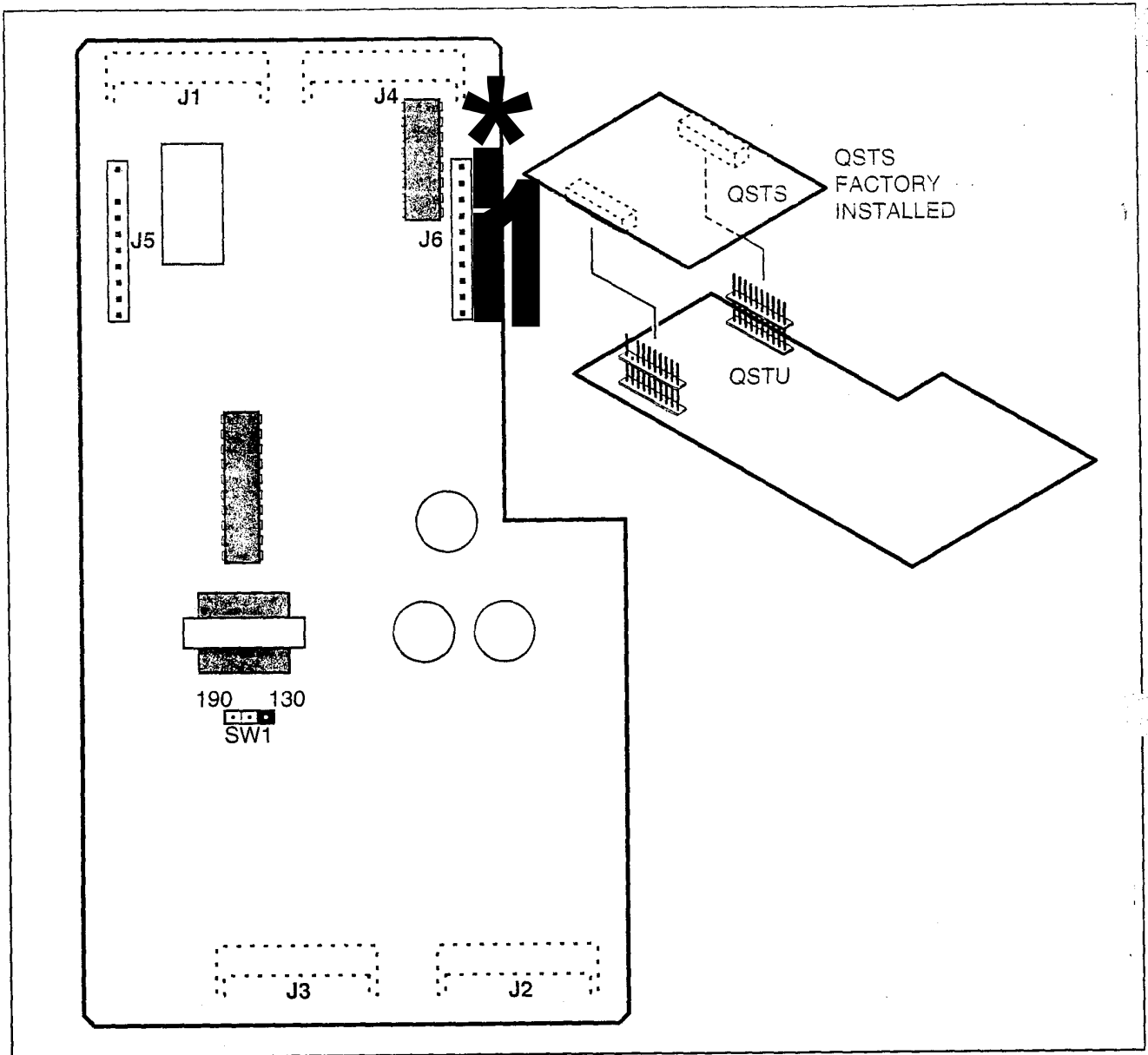
#### NOTE:

*QSTU Ports are fixed. They are assigned even if a QSTU is not installed.*

## 9 DTMF RECEIVER/ABR TONE DETECTOR UNIT (QRCU)

### 9.00 General

9.01 The QRCU must be installed to recognize Dual-Tone Multi-Frequency (DTMF) tones gener-



**FIGURE 4-10**  
**QSTU CONTROLS AND INTERFACE CONNECTORS**

ated by a standard telephone (or any other device connected to a standard telephone circuit (QSTU)), and it is required for Direct Inward System Access (DISA) calls. The QRCU circuits are also used to detect busy tone for the Automatic Busy Redial (ABR) feature and must be installed to allow ABR to operate.

**9.02** The QRCU is shown in Figure 4-11.

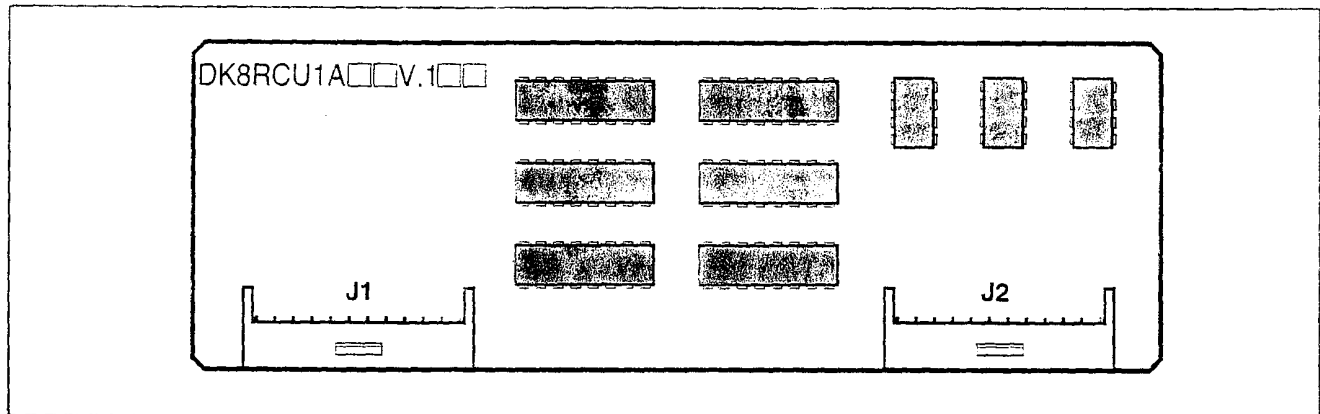
**9.10 QRCU Configuration**

**9.11** The QRCU does not have to be configured for operation.

**9.20 QRCU Installation Procedure**

**9.21** Install the QRCU in accordance with the following steps (Figure 4-7).





**FIGURE 4-11**  
**QRCU INTERFACE CONNECTORS**

- 1) Remove the PCB from its protective packaging.
- 2) Make sure that the power supply switch is OFF.
- 3) Align and insert QRCU connectors **J1** and **J2** into motherboard connectors **J15** and **J16** respectively (note the component side placement in Figure 4-7), and apply firm, even pressure to ensure proper mating of connectors. Push down until connectors lock together.

### 9.30 QRCU Wiring

9.31 The QRCU does not require any wiring.

### 9.40 QRCU Programming Overview

9.41 The following parameters may be specified:

#### Program 12

- Set QRCU release time.

#### Program 15

- Sets QRCU operation after CO line flash.

## 10 CONFERENCE CIRCUITS (QCNU)

### 10.00 General

10.01 The QCNU provides two conference circuits which allow two simultaneous conferences (one four-party and one three-party). The QCNU is standard and is installed at the factory. If it is necessary

to remove and replace the QCNU, turn the system off, remove the QCNU, and install another QCNU per paragraph 10.20.

10.02 The QCNU is shown in Figure 4-7.

### 10.10 QCNU Configuration

10.11 The QCNU does not have to be configured for operation.

### 10.20 QCNU Installation Procedure

10.21 Install the QCNU in accordance with the following steps (Figure 4-7):

- 1) Remove the PCB from its protective packaging.
- 2) Make sure that the power supply switch is OFF.
- 3) Align and insert QCNU connectors **J1** and **J2** into motherboard connectors **J17** and **J18** respectively, and apply firm, even pressure to ensure proper mating of connectors. (Note the side with "→ **RIGHT**" silkscreened on it should be positioned as shown in Figure 4-7.)

### 10.30 QCNU Wiring

10.31 The QCNU does not require any wiring.

### 10.40 QCNU Programming Overview

10.41 The QCNU does not require any programming.

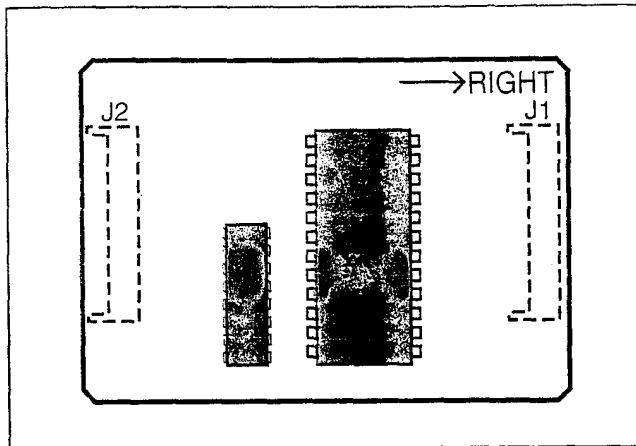


FIGURE 4-12  
 QGNU INTERFACE CONNECTORS

## 11 OPTION INTERFACE UNIT (QSMU)

### 11.00 General

11.01 The QSMU provides a circuit interface with peripheral options.

11.02 The QSMU is shown in Figure 4-13.

### 11.10 QSMU Hardware Options

11.11 The QSMU supports the following STRATA DK8 external hardware options:

- SMDR output or TTY (maintenance) port two-way interface.

**NOTE:**

*Refer to Peripheral Equipment Installation, Section 100-816-207, for installation of SMDR and the Remote Maintenance Section 100-816-600 for TTY.*

### 11.20 QSMU Configuration

11.21 The QSMU must be configured for operation with the appropriate external hardware: either an SMDR printer or call accounting device; Remote Maintenance Terminal (TTY) or modem; and in System Program 10-3:

- LED 04 ON — TTY
- LED 04 OFF — SMDR

### 11.30 QSMU Installation Procedure

11.31 Install the QSMU in accordance with the following steps (See Figure 4-7):

- 1) Remove the PCB from its protective packaging.
- 2) Ensure the QSMU has been configured for the appropriate program options (refer to Paragraphs 11.10 and 11.20).
- 3) Slide the QSMU under the "System Frame Ground Bar", align and insert QSMU connector **J2** into motherboard connector **J20**, ensuring the side of the QSMU with the modular connector goes on the right side. (The QSMU is not silkscreened "→ **RIGHT**".) Apply firm, even pressure to ensure proper mating of connectors. Make sure the edge of the QSMU opposite connector **J2** snaps firmly into the standoffs on the KSU motherboard.
- 4) Remove the "knock-out" from the KSU cover **SMDR/TTY** access slot, and store the "knock-out" in the slots provided in the KSU base (Figure 4-9).

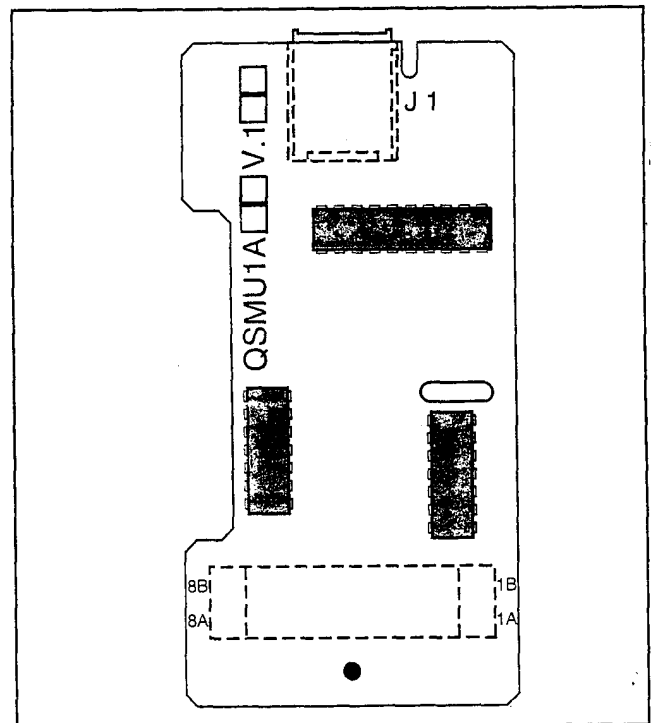


FIGURE 4-13  
 QSMU CONTROLS AND INTERFACE CONNECTORS

### 11.40 QSMU Wiring

**11.41** Refer to Peripheral Equipment Installation (Section **100-816-207, SMDR**) and Remote Maintenance (Section **100-816-600, TTY**) for QSMU wiring/interconnecting details.

### 11.50 QSMU Programming Overview

**11.51** The following parameters may be specified, through programming, for the QSMU:

#### Program 60

- Assigns SMDR options.

#### Program 10-3

- LED04-SMDR/TTY Select option.

### 11.60 Device Communication Parameters

**11.61** Set the communication parameters for the device connected to the QSMU SMDR/TTY jack as follows:

- TTY: 7 Bits, 1-Stop Bit, Even Parity
- SMDR: 8 Bits, 1-Stop Bit, Odd Parity
- TTY/SMDR: 1200 bps

## 12 BUILT-IN CO LINE, DIGITAL TELEPHONE, AND OTHER CIRCUITS

### 12.00 General

**12.01** As mentioned in Paragraph 6, the KSU comes standard with two CO lines and four digital telephone circuits already installed.

### 12.10 Built-in CO Line Circuits

**12.11** The two standard loop start CO line circuits are integrated into the KSU motherboard and are identical to the QCDU CO line circuits. For wiring and programming considerations, see the QCDU instructions in Paragraph 7.

### 12.20 Built-in Digital Telephone Circuits

**12.21** The four digital telephone circuits that come standard with the system are integrated into the motherboard in the KSU. These circuits are identical to the digital circuits found on the QCDU. The motherboard does not have to be configured for the digital circuits to operate. For wiring and programming considerations, see the QCDU instructions in Paragraph 7.

### 12.30 KSU Motherboard CO Line/Digital Station Circuit Wiring

**12.31** Refer to Section **100-816-208** for details.

- Station circuits: DK8 MDF to KSU Amphenol Wiring Diagram
- CO lines: DK8 MDF TO CO Line (KSU and QCDU) Wiring Diagram

### 12.40 Power Failure Telephone Installation

- 1) Remove the RJ11 cover (Figure 4-9) from the PFT jack and store the jack cover.
- 2) Connect the power failure telephone (500/2500-type standard telephone) to the PFT jack. (Refer to the DK8 MDF to CO Line Wiring Diagram in Section **100-816-208**.)

### 12.50 Music-On-Hold (MOH)/Background Music (BGM) Source Connection

**12.51** Connect the MOH/BGM source to the MOH RCA jack (Figure 4-7) in accordance with Music Source Configuration A in Section **100-816-207**.

### 12.60 External Page Output Connection

**12.61** Connect the external page system to the 600Ω PAGE RCA output jack (Figure 4-7) to an external amplifier in accordance with the External Page Installation guidelines in Section **100-816-207**.

# ***Strata***<sup>®</sup> *DK16*

## **INSTALLATION**

### **CHAPTER FIVE DK16 KSU AND PCB INSTALLATION**

TABLE OF CONTENTS

PARAGRAPH	SUBJECT	PAGE
<b>PART I</b>		
	<b>DK16 KSU INSTALLATION .....</b>	<b>5-1</b>
1	GENERAL .....	5-1
2	<b>DK KEY SERVICE UNIT MOUNTING .....</b>	<b>5-1</b>
2.00	Mounting Surface Considerations .....	5-1
2.10	Mounting Preparation .....	5-1
2.20	Mounting the Base Key Service Unit .....	5-1
2.30	Mounting the Expansion Key Service Unit .....	5-4
2.40	Reserve Power Failure Options .....	5-10
3	<b>POWER SUPPLY REMOVAL AND REPLACEMENT .....</b>	<b>5-11</b>
3.10	Power Supply Removal .....	5-11
3.20	Power Supply Replacement .....	5-12
<b>PART II</b>		
	<b>DK16 PRINTED CIRCUIT BOARD INSTALLATION .....</b>	<b>5-13</b>
4	GENERAL .....	5-13
5	<b>PCB INSTALLATION CONSIDERATIONS .....</b>	<b>5-13</b>
5.10	Base Unit PCBs .....	5-13
5.20	Expansion Unit PCBs .....	5-13
5.30	PCB Option Considerations .....	5-13
5.40	PCB Installation/Power Supply Considerations .....	5-14
6	<b>BASE UNIT STANDARD TELEPHONE INTERFACE UNIT (KSTU) .....</b>	<b>5-14</b>
6.00	General .....	5-14
6.10	KSTU Configuration .....	5-14
6.20	KSTU Installation Procedure .....	5-14
6.30	KSTU Wiring .....	5-15
6.40	KSTU Programming Overview .....	5-15
7	<b>DIGITAL TELEPHONE INTERFACE UNIT (PDKU) .....</b>	<b>5-15</b>
7.00	General .....	5-15
7.10	PDKU Hardware Options .....	5-16
7.20	PDKU Installation Procedure .....	5-17
7.30	PDKU Wiring .....	5-17
7.40	PDKU Programming Overview .....	5-17
8	<b>ELECTRONIC TELEPHONE INTERFACE UNIT (PEKU) .....</b>	<b>5-17</b>
8.00	General .....	5-17
8.10	PEKU Hardware Options .....	5-17
8.20	PEKU Installation Procedure .....	5-19
8.30	PEKU Wiring .....	5-20
8.40	PEKU Programming Overview .....	5-20
9	<b>STANDARD TELEPHONE INTERFACE UNIT (PSTU) .....</b>	<b>5-20</b>
9.00	General .....	5-20
9.10	PSTU (1 and 2) Hardware Options .....	5-20
9.20	PSTU Installation Procedure .....	5-21
9.30	PSTU Wiring .....	5-22
9.40	PSTU Programming Overview .....	5-22

TABLE OF CONTENTS (continued)

PARAGRAPH	SUBJECT	PAGE
10	STANDARD/ELECTRONIC TELEPHONE INTERFACE UNIT (PESU) .....	5-22
10.00	General .....	5-22
10.10	PESU Hardware Options .....	5-22
10.20	PESU Installation Procedure .....	5-25
10.30	PESU Wiring .....	5-25
10.40	PESU Programming Overview .....	5-25
11	CO LINE UNIT (PCOU) .....	5-25
11.00	General .....	5-25
11.10	PCOU Hardware Options .....	5-25
11.20	PCOU Installation Procedure .....	5-25
11.30	PCOU Wiring .....	5-26
11.40	PCOU Programming Overview .....	5-26
12	OPTION INTERFACE UNIT (PIOU AND PIOUS) .....	5-28
12.00	General .....	5-28
12.10	PIOU and PIOUS Hardware Options .....	5-28
12.20	PIOU and PIOUS Installation Procedure .....	5-30
12.30	PIOU and PIOUS Wiring .....	5-30
12.40	PIOU and PIOUS Programming Overview .....	5-30
13	CO LINE/DIGITAL TELEPHONE INTERFACE UNIT (KCDU) .....	5-31
13.00	General .....	5-31
13.10	KCDU Configuration .....	5-31
13.20	KCDU Installation Procedure .....	5-31
13.30	KCDU Wiring .....	5-33
13.40	KCDU Programming Overview .....	5-33
14	DTMF RECEIVER/ABR TONE DETECTOR UNIT (K4RCU) .....	5-33
14.00	General .....	5-33
14.10	K4RCU Configuration .....	5-33
14.20	K4RCU Installation Procedure .....	5-33
14.30	K4RCU Wiring .....	5-34
14.40	K4RCU Programming Overview .....	5-34
15	BUILT-IN CO LINE AND DIGITAL TELEPHONE CIRCUITS .....	5-34
15.00	General .....	5-34
15.10	Built-in CO Line Circuits .....	5-34
15.20	Digital Telephone Circuits .....	5-34
15.30	Base Unit CO Line/Digital Station Circuit Wiring .....	5-34
16	KCOU REMOVAL AND REPLACEMENT .....	5-35
16.00	General .....	5-35
16.10	KCOU Removal .....	5-35
16.20	KCOU Replacement .....	5-35
17	DK16 POWER FAILURE EMERGENCY TRANSFER OPTION .....	5-36
17.10	DK16 Power Failure Emergency Transfer Installation .....	5-36

**FIGURE LIST**  
**TITLE**

<b>FIGURE</b>	<b>TITLE</b>	<b>PAGE</b>
5-1	DK16 BASE KEY SERVICE UNIT EXTERIOR .....	5-2
5-2	DK16 BASE KEY SERVICE UNIT WALL MOUNTING METHODS .....	5-3
5-3	DK16 BASE KEY SERVICE UNIT INTERIOR .....	5-3
5-4	DK16 BASE KEY SERVICE UNIT WIRING CONNECTIONS .....	5-5
5-5	CONNECTING THE DK16 EXPANSION UNIT TO THE DK16 BASE UNIT .....	5-6
5-6	MOUNTING THE DK16 EXPANSION UNIT .....	5-7
5-7	DK16 EXPANSION UNIT INTERIOR .....	5-8
5-8	DK16 EXPANSION UNIT WIRING CONNECTIONS .....	5-9
5-9	POWER SUPPLY (KPSU) .....	5-11
5-10	BASE UNIT POWER FAILURE TRANSFER (PFT) CIRCUIT DIAGRAM .....	5-12
5-11	KSTU OPTIONS AND CONNECTORS .....	5-14
5-12	PDKU INTERFACE CONNECTION .....	5-16
5-13	PEKU CONTROLS AND INTERFACE CONNECTORS .....	5-18
5-14	OFF-HOOK CALL ANNOUNCE UNIT (EOCU) INTERFACE CONNECTORS .....	5-20
5-15	PSTU AND SUBUNIT (SSTU) .....	5-21
5-16	PESU PCB OPTION LOCATION AND IDENTIFICATION .....	5-23
5-17	PCOU CONTROLS, INDICATORS, AND INTERFACE CONNECTORS .....	5-26
5-18	PIOU CONTROLS, INDICATORS, AND INTERFACE CONNECTORS .....	5-28
5-19	PIOUS PCB SWITCH/JUMPER, OPTION LOCATION .....	5-30
5-20	REMOTE MAINTENANCE MODEM UNIT (IMDU) INTERFACE CONNECTORS ...	5-32
5-21	KCDU INDICATORS, OPTIONS AND CONNECTORS .....	5-32
5-22	K4RCU PCB .....	5-34
5-23	KCOU PCB .....	5-35
5-24	EMERGENCY STANDARD TELEPHONE INSTALLATION .....	5-36

**TABLE LIST**

<b>TABLE</b>	<b>SUBJECT</b>	<b>PAGE</b>
5-A	KSTU CONTROLS AND INTERFACE CONNECTORS .....	5-15
5-B	PEKU CONTROLS AND INTERFACE CONNECTORS .....	5-19
5-C	PSTU CONTROLS AND INTERFACE CONNECTORS .....	5-21
5-D	PESU CONTROLS AND INTERFACE CONNECTORS .....	5-24
5-E	PCOU CONTROLS, INDICATORS, AND INTERFACE CONNECTORS .....	5-27
5-F	PIOU CONTROLS AND INTERFACE CONNECTORS .....	5-29
5-G	PIOUS CONTROLS AND INTERFACE CONNECTORS .....	5-31
5-H	KCDU CONTROLS, INDICATORS, AND CONNECTORS .....	5-33

**IMPORTANT INITIAL INSTALLATION NOTES!**

*These minimum installation steps must be carried out for proper system operation.*

1. *Set the SW1 switch in the Base Unit ON for BATTERY OPERATION; otherwise, all programmed customer data will be lost on power down.*
2. *If required, install KSTU and K4RCU in the Base Unit.*
3. *If the system is configured with an Expansion Unit, follow the order prescribed below:*
  - a) *Install PDKU, PEKU, PSTU, PESU, or KCDU in Slot 04.*
  - b) *If installing two KCDUs, install a KCDU in Slot 05. (The other KCDU should be installed in Slot 04.)*
  - c) *If the system is configured with a PCOU, install it in Slot 05. (The system cannot be configured with both a PCOU and KCDU in the Expansion Unit.)*
  - d) *If the system is configured with a PIOUS or PIOUS, install it in Slot 06. (Slot 07 should be reserved for future use.)*
4. *Initialize Programs 00 ~ 97 by running Program 90.*
5. *Run Program 92.*
6. *Enter the hardware configuration with Program 03, exit the programming mode, turn power OFF for five seconds, then turn power back ON.*

**WHEN LATER ADDING KSU PCBs**

1. *Install new PCBs and set the new configuration with Program 03. (Turn power OFF for five seconds after running Program 03.)*
2. *Program new features, options, etc. created by new additions.*



## PART I. KSU INSTALLATION

### 1 GENERAL

**1.00** This chapter provides the instructions necessary to mount both the STRATA DK16 Base Key Service Unit and the Expansion Key Service Unit. Instructions are also provided on how to test, remove, and replace the power supply and base unit CO line interface subassembly.

### 2 KEY SERVICE UNIT MOUNTING

#### 2.00 Mounting Surface Considerations

**2.01** The Base Key Service Unit and the optional Expansion Key Service Unit are both designed to be mounted on a wall or other vertical surface. It is recommended to use Method 1 or 2 in Figure 5-2 (see Note).

**NOTE:**

*If mounting the KSU directly to a wall, be sure to align screws with studs behind the wall; if using a hard board between the KSU and the wall, install screws first to the hard board, and then secure the hard board to the wall, making certain that screws are aligned with studs.*

#### 2.10 Mounting Preparation

- 1) Loosen the screws on the front cover and the side cover of the Base Key Service Unit, and remove the covers (Figure 5-1).
- 2) Move the **SW1** Memory Battery Backup strap on the motherboard to the ON position (Figure 5-3).
- 3) If applicable, install the K4RCU into the Base Key Service Unit (see Paragraph 14).
- 4) If applicable, install the KSTU into the Base Key Service Unit (see Paragraph 6).
- 5) Plug the AC power cable into an outlet (Figure 5-3).
  - The "AC" LED on the power supply will light green (If not, refer to the Fault Finding section later in this manual).

- 6) Turn the switch on the power supply to the ON position (Figure 5-3).
  - The "DC" LED on the power supply will light green. (If not, refer to the Fault Finding section later in this manual).
- 7) Using a voltmeter or other device which checks voltage, measure the voltages referenced to frame ground (FG) at the **DC OUT connector pins** (test points) located on the motherboard (Figure 5-3). The voltages should fall within the ranges below. If the voltages do not fall within the ranges, unplug the DC power pins from the DC OUT connector and measure again at the same location; if the ranges remain unacceptable, replace the power supply (see Paragraph 3).
  - Yellow-Green, Black, and Green Wires: 0V
  - Yellow Wire: -24V
    - Range: -26.3V ~ -27.8V
  - Red Wire: 5V
    - Range: 4.5V ~ 5.5V
  - Blue Wire: -5V
    - Range: -4.5V ~ -5.5V

#### 2.20 Mounting the Base Key Service Unit

- 1) Make sure the power supply switch is turned OFF.
- 2) Place the Base Key Service Unit on the desired location on the mounting surface and mark the location of the four screw holes (there is one on each corner). See Figure 5-2.

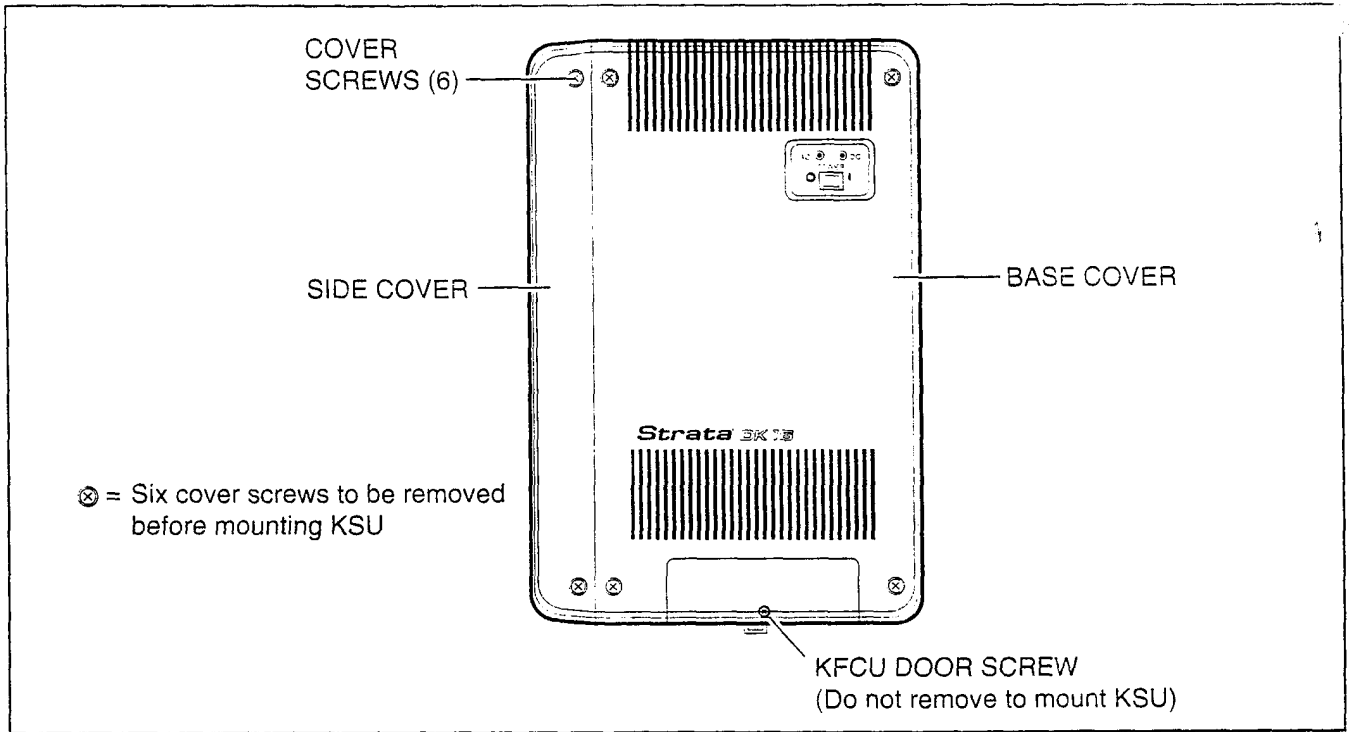
**NOTE:**

*Make sure the location of the Base Key Service Unit meets the minimum clearance requirements specified in Figure 2-2 in Chapter 2.*

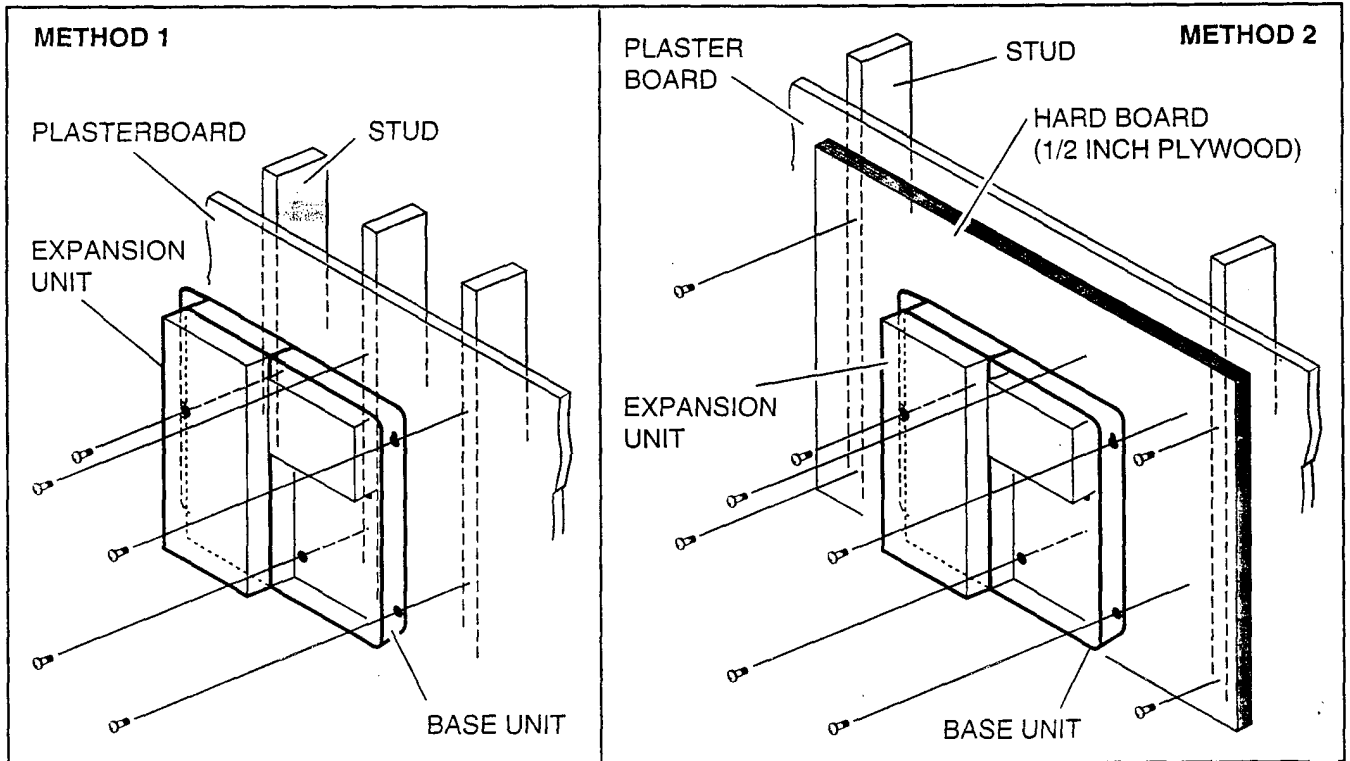
- 3) Drill holes on these marks.

**NOTE:**

*If mounting the KSU directly to a wall, be sure to align screws with studs behind the wall; if using a hard board between the KSU and the wall, install screws first to the hard board, and then secure the hard board to the wall, making certain that screws are aligned with studs.*



**FIGURE 5-1**  
**DK16 BASE KEY SERVICE UNIT EXTERIOR**



**FIGURE 5-2**  
**DK16 BASE KEY SERVICE UNIT WALL MOUNTING METHODS**

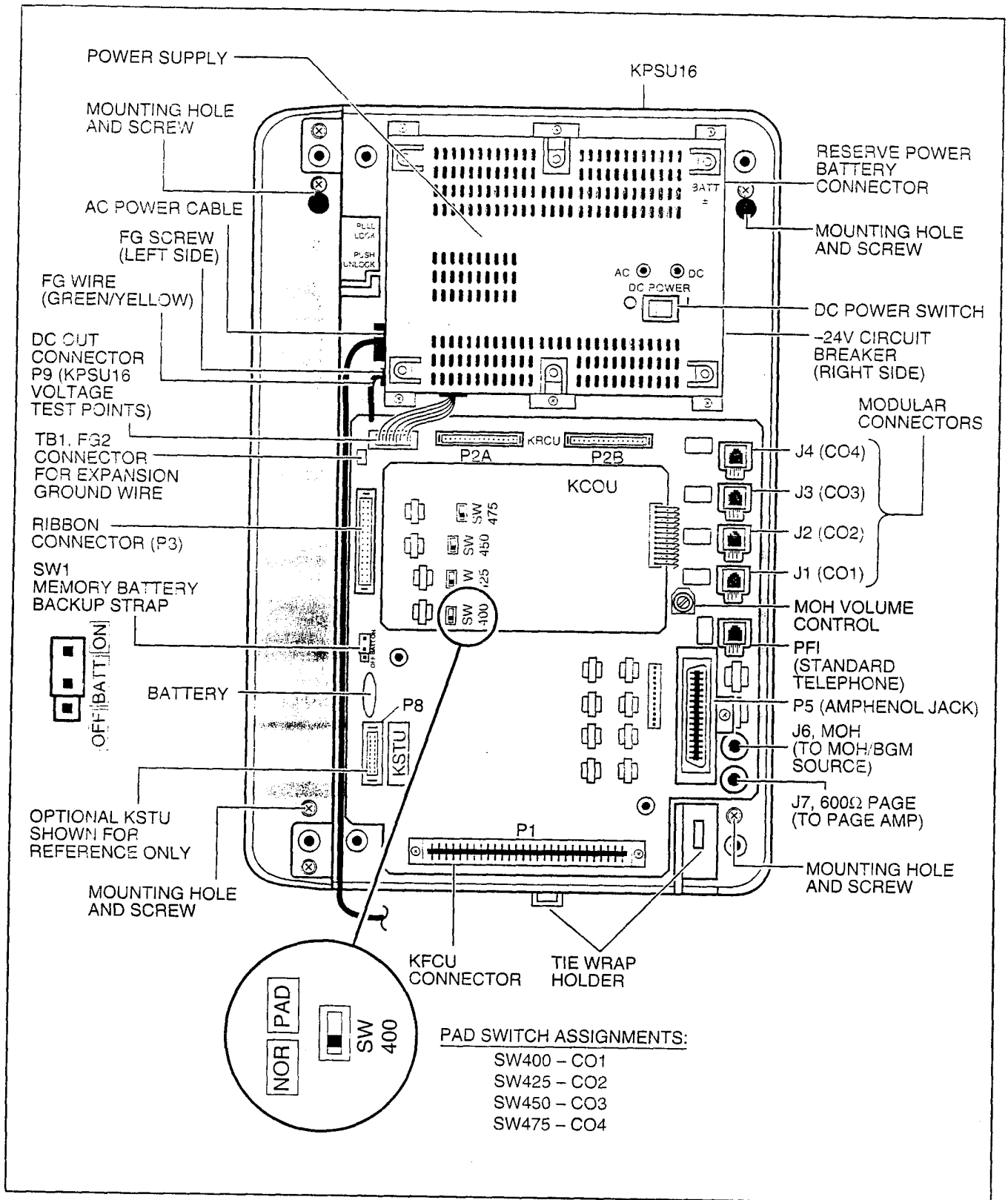
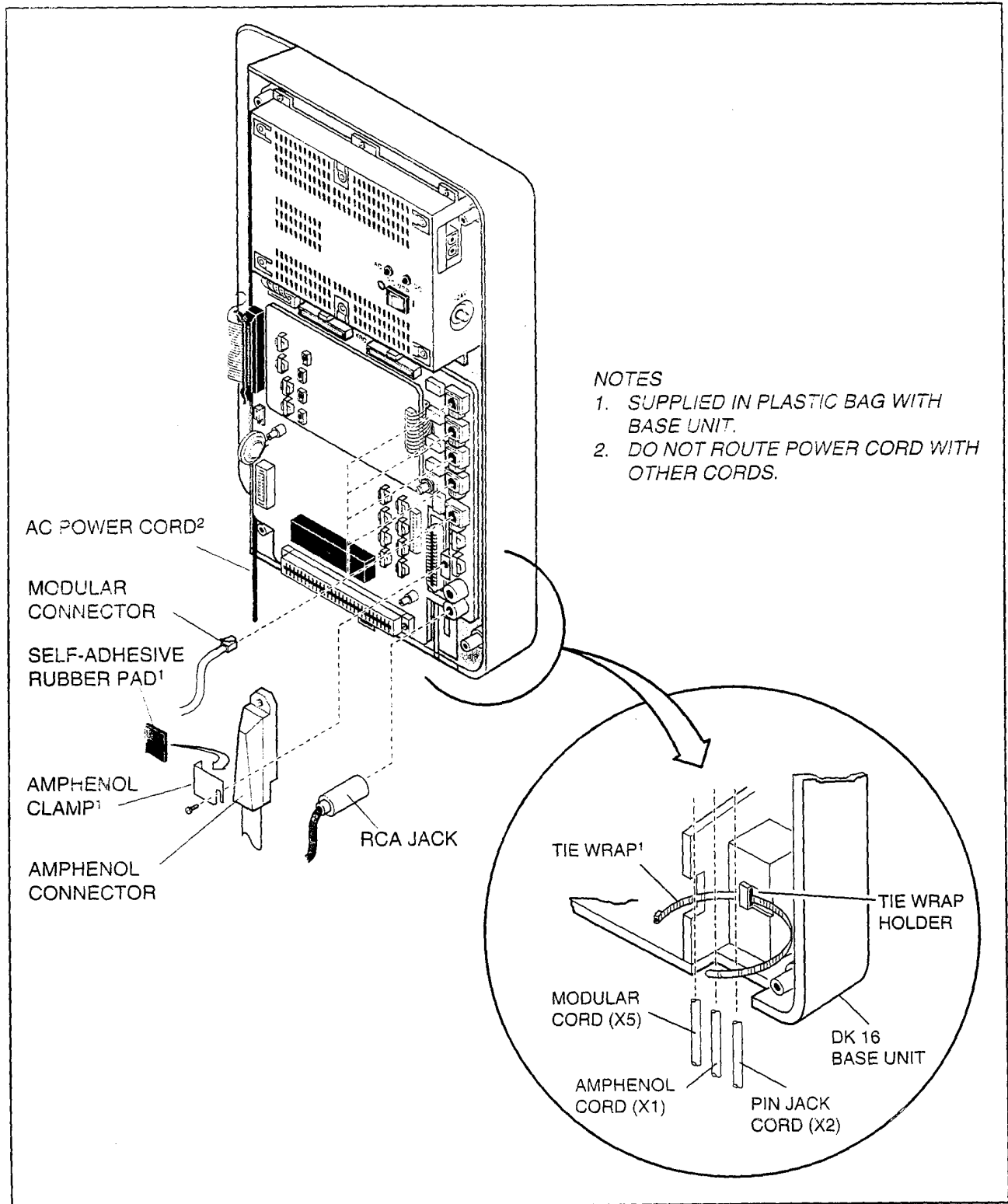


FIGURE 5-3  
DK16 BASE KEY SERVICE UNIT INTERIOR

- 4) Secure screws approximately two thirds of the way into the top two holes on the mounting surface.
  - 5) Hang the unit from the top two screws and then secure the screws completely into the mounting surface.
  - 6) Finish securing the unit to the mounting surface by completely screwing the bottom two screws into the wall.
  - 7) Ground system according to Chapter 2, paragraph 4.
  - 8) Connect applicable wiring (modular CO line cords, 25-pair amphenol connector cable, etc.) to the Base Key Service Unit and then fasten wiring to the unit with the tie wrap that comes with the base unit (Figure 5-4). Remove amphenol connector clamp from plastic bag that comes with the Base Unit. Fasten the clamp to hold the amphenol connector.
  - 9) Connect Reserve batteries (per Paragraph 2.40) and plug battery cable into BATT connector of the KPSU16 power supply (Figure 5-3 and 5-4).
  - 10) Set the KCOU PAD switches (SW400-SW475) to the appropriate position (Figure 5-3). The factory setting is NORMAL. If CO lines are connected to a PBX or are in close proximity to the central office the PAD position may be required.
  - 11) If the Expansion Key Service Unit is going to be installed, refer now to Paragraph 2.30. If not, proceed to Step 12.
  - 12) Plug the AC power cable into an outlet and then turn ON the power supply switch.
  - 13) Reinstall the front and side covers onto the Base Key Service Unit.
- 2.30 Mounting the Expansion Key Service Unit**
- 1) Make sure the side cover is removed from the Base Key Service Unit. Turn Base Key Service Unit DC power switch off.
  - 2) Set the Expansion Key Service Unit on the Base Key Service Unit's hinge mounts, making sure that the Expansion Unit sets properly in place (Figure 5-5).
  - 3) Remove safety lock from plastic bag which comes with the Expansion Unit. Install safety lock to the Base Unit as shown in Figure 5-5.
  - 4) Pull out on the safety lock until it can no longer be moved, securing the Expansion Key Service Unit to the Base Key Service Unit (Figure 5-5). Do not detach the lock from the Base Key Service Unit.
  - 5) Connect the Expansion Key Service Unit Ribbon Cable to the connector on the Base Key Service Unit (Figure 5-5). Close ribbon cable connector lock on Base Unit.
  - 6) Connect Expansion Unit green/yellow ground wire plug (FG2) to TB1 of the Base Unit. (Make sure the plug locks on TB1.) See Figure 5-3 and 5-4.
  - 7) Making sure that the Expansion Key Service Unit is flush against the mounting surface, mark the location of the Expansion Unit mounting screw hole (Figure 5-6).
  - 8) Swing the Expansion Key Service Unit away from the mounting surface, and drill a hole at the mark made in Step 7.
  - 9) Install applicable printed circuit boards (PCBs) (see Chapter 5, Section II)—after PCBs are installed, slide the slot lock to the lock position (Figure 5-7).
  - 10) Swing the Expansion Key Service Unit back to the mounting surface and secure it to the surface with a screw.
  - 11) Connect applicable wiring (modular CO line cords, 25-pair amphenol connector, etc.) to the PCBs (Figure 5-8).
  - 12) Fasten the wiring with tie wraps (supplier) to the bottom of the Expansion and Base Key Service Units (Figure 5-8).



**FIGURE 5-4**  
**DK16 BASE KEY SERVICE UNIT WIRING CONNECTIONS**

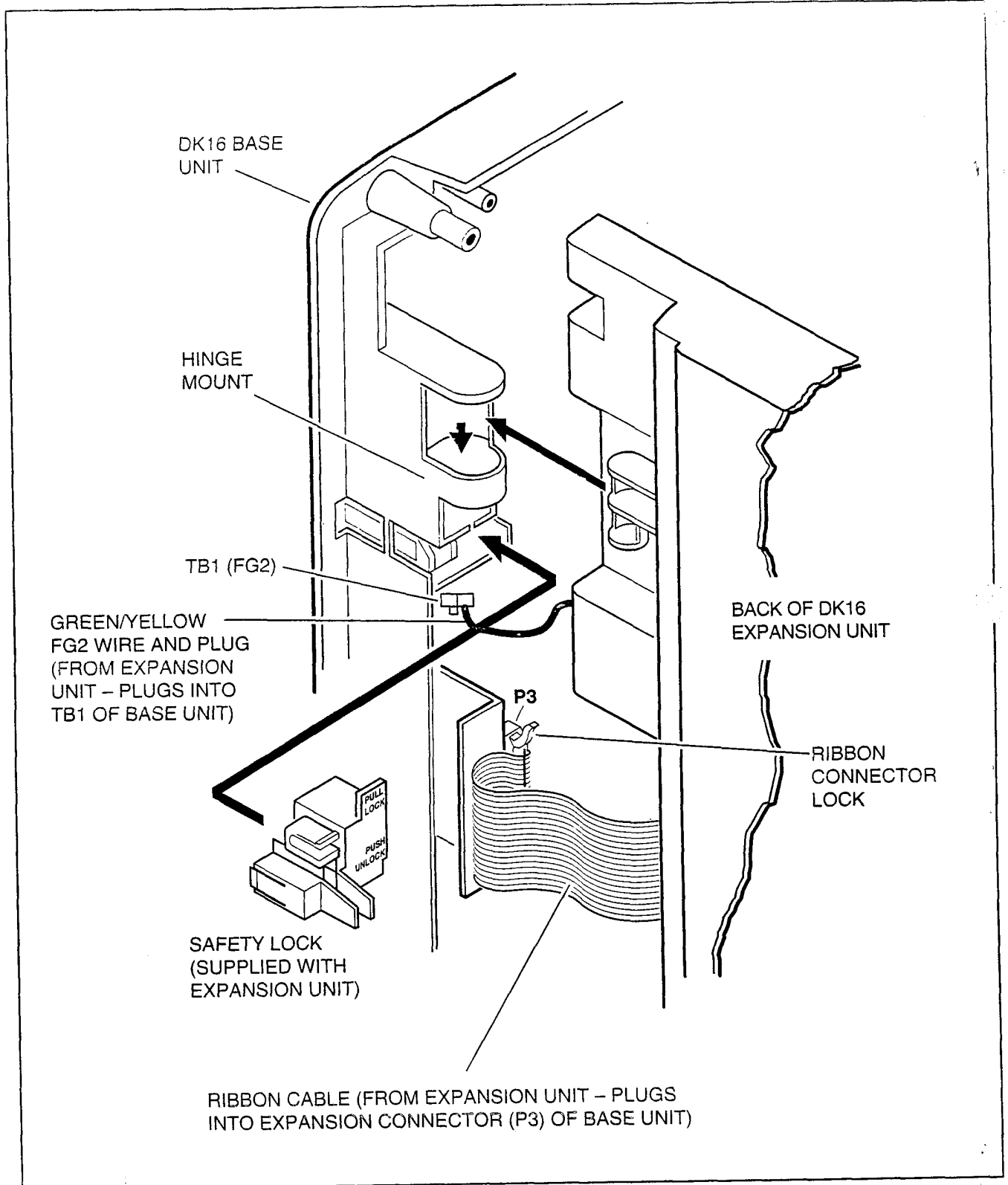
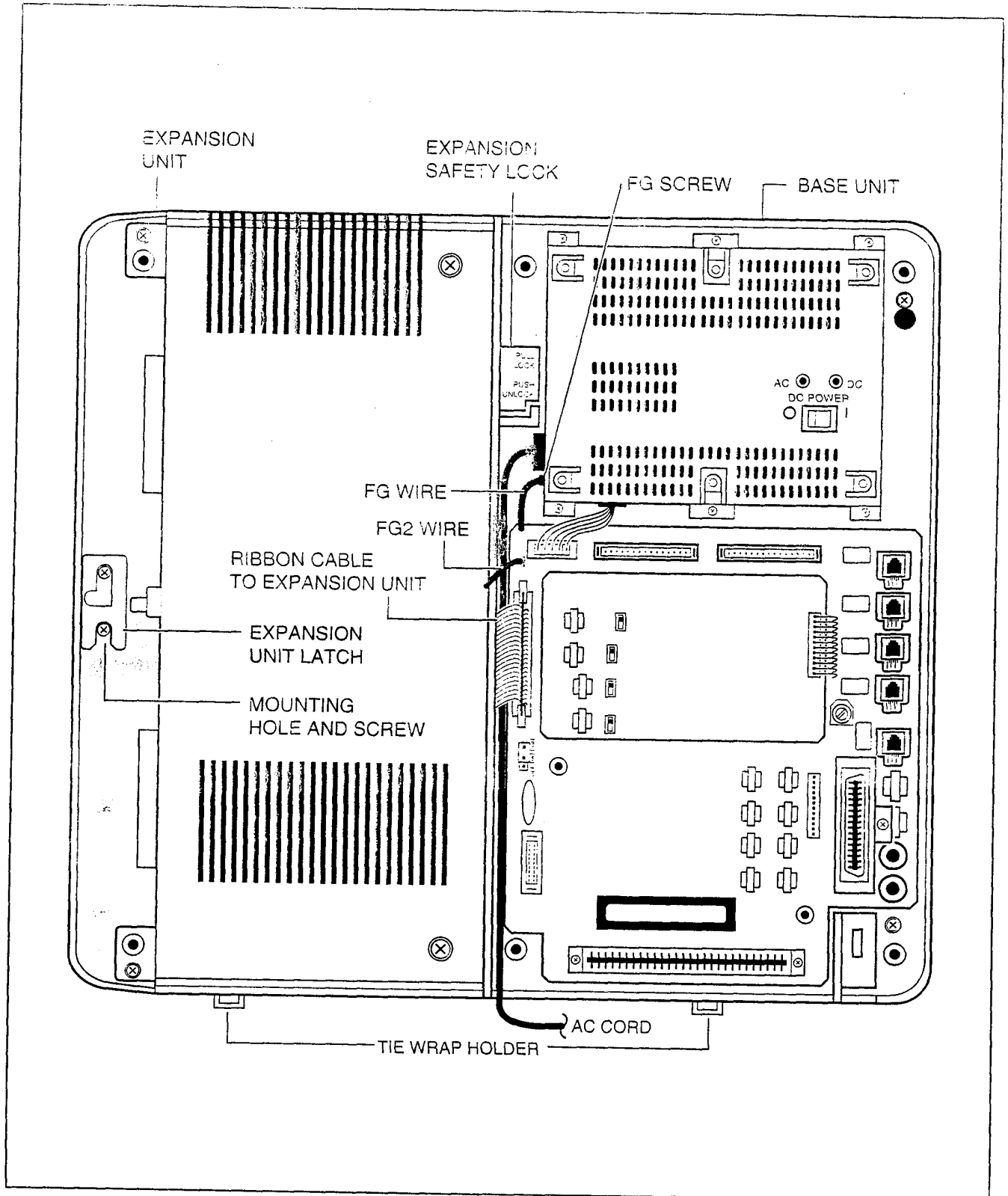
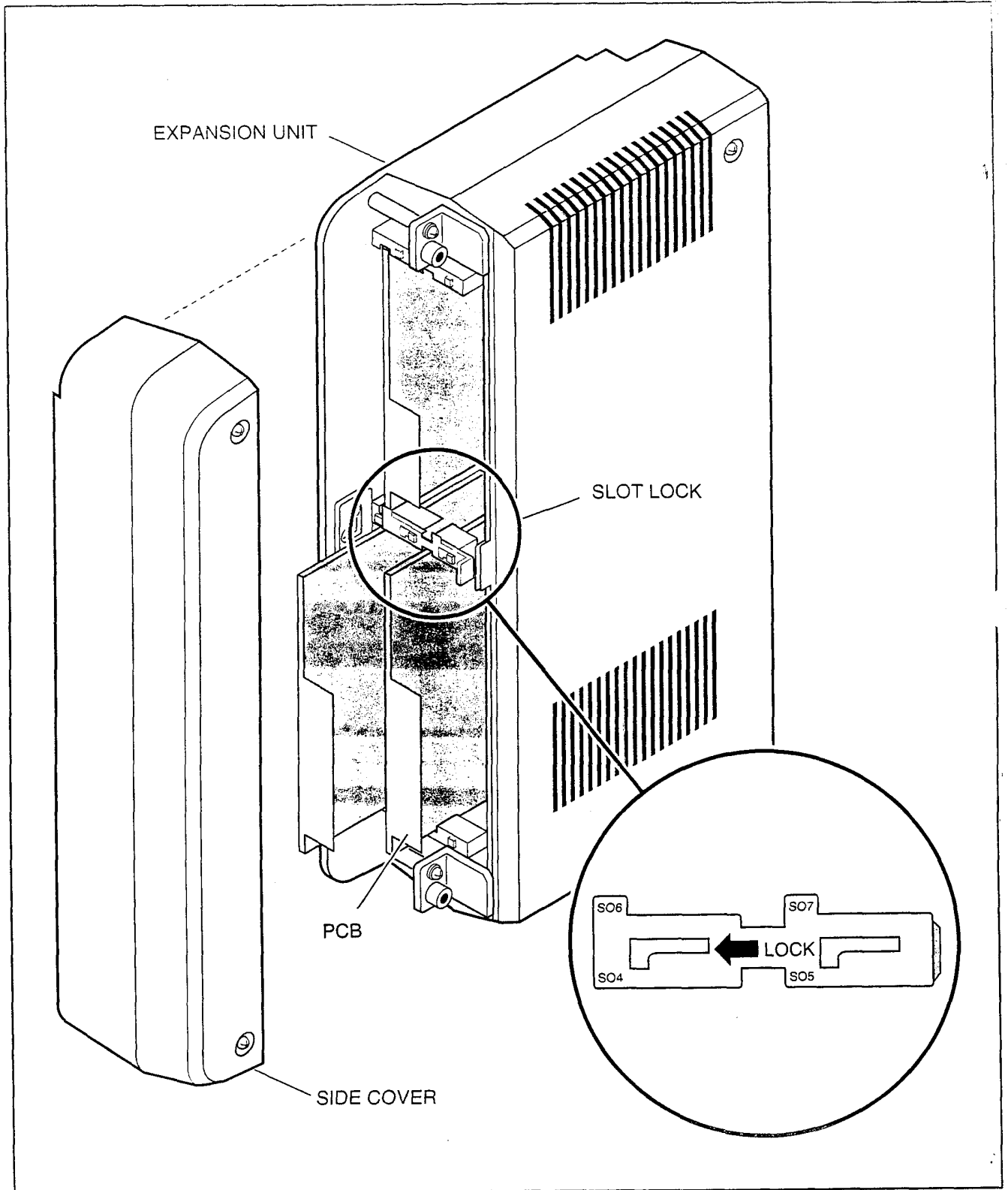


FIGURE 5-5  
CONNECTING THE DK16 EXPANSION UNIT TO THE DK16 BASE UNIT



**FIGURE 5-6**  
**MOUNTING THE DK16 EXPANSION UNIT**



**FIGURE 5-7**  
**DK16 EXPANSION UNIT INTERIOR**



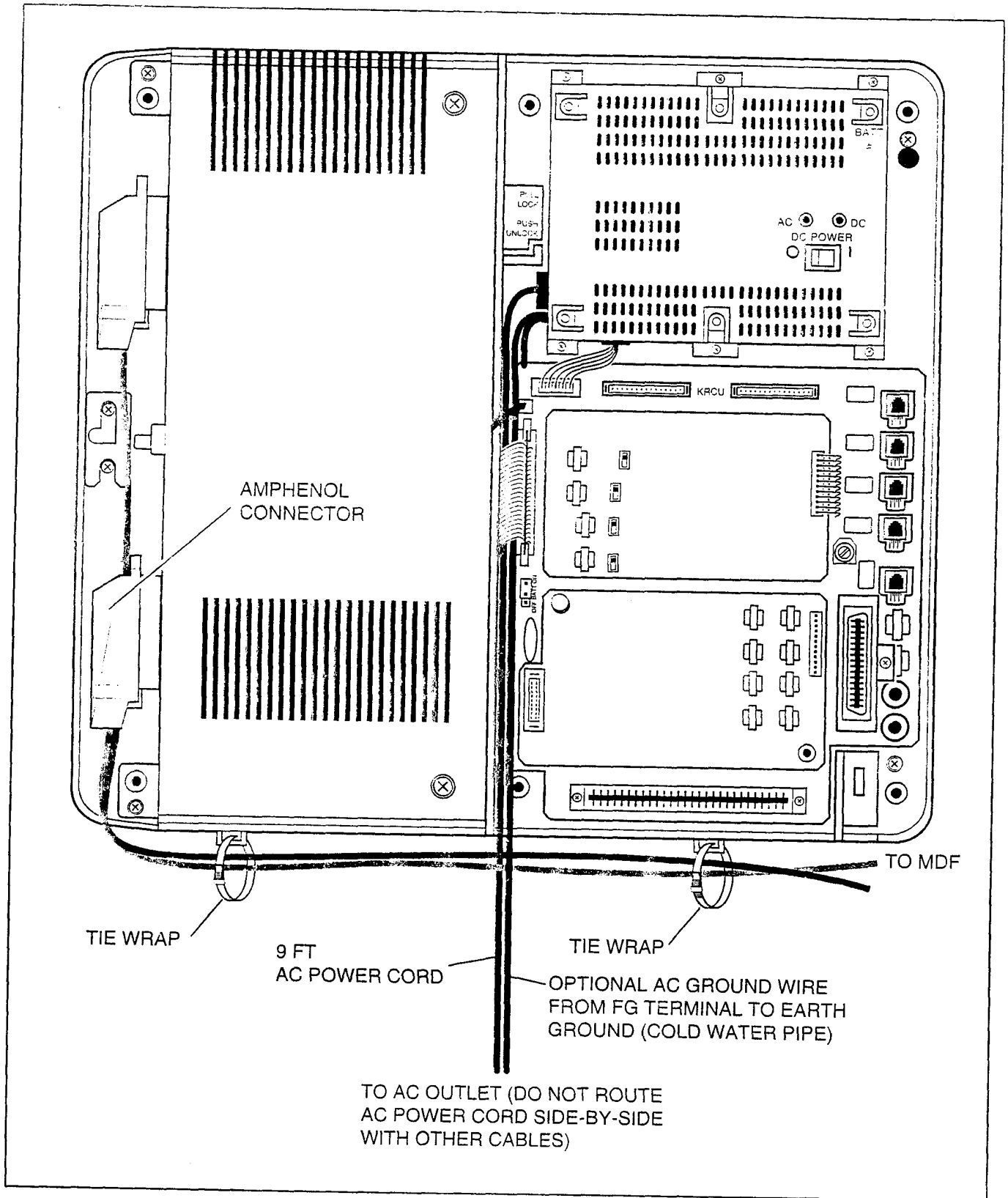


FIGURE 5-8  
DK16 EXPANSION UNIT WIRING CONNECTIONS

- 13) Knock out the tab on the bottom of the side cover.
- 14) Plug the AC power cable into an outlet and then turn ON the power supply switch.
- 15) Install the side cover to the Expansion Key Service Unit (Figure 5-7).

#### 2.40 Reserve Power/Power Failure Options

2.41 The STRATA DK systems offer two options to protect system operation in the event of a power failure; the Reserve Power option (Paragraph 2.42-2.44), and the Power Failure Emergency Transfer option (Paragraph 17).

2.42 **Reserve Power Option** STRATA DK16 system power supply provides the capability of connecting a reserve power source (two customer supplied 12-volt batteries) to ensure uninterrupted system operation in the event of a power failure. A pre-assembled interface cable for installation of the Reserve Power option is available from Toshiba (PBTC-3M), refer to Figure 5-9.

#### **IMPORTANT NOTE!**

**Local ordinances may dictate battery type and installation details.**

2.43 The batteries require a well-ventilated location close (within 9 feet) to the system —the interface cable is 9 feet long.

#### **WARNING!**

**To reduce the risk of fire or injury to persons, read and follow these instructions:**

1. **Use only the following type and size batteries: 12-volt, gelcell.**
2. **Do not dispose of the batteries in a fire. The cells may explode. Check with local codes for possible special disposal instructions.**
3. **Do not open or mutilate the batteries. Released electrolyte is corrosive and may cause damage to the eyes or skin. It may be toxic if swallowed.**

4. **Exercise care in handling batteries in order not to short the battery with conduction materials such as rings, bracelets, and keys. The battery or conductor may overheat and cause burns.**
5. **Charge the batteries provided with or identified for use with this product only in accordance with the instructions and limitations specified in this manual.**
6. **Observe proper polarity orientation between the batteries and battery charger.**

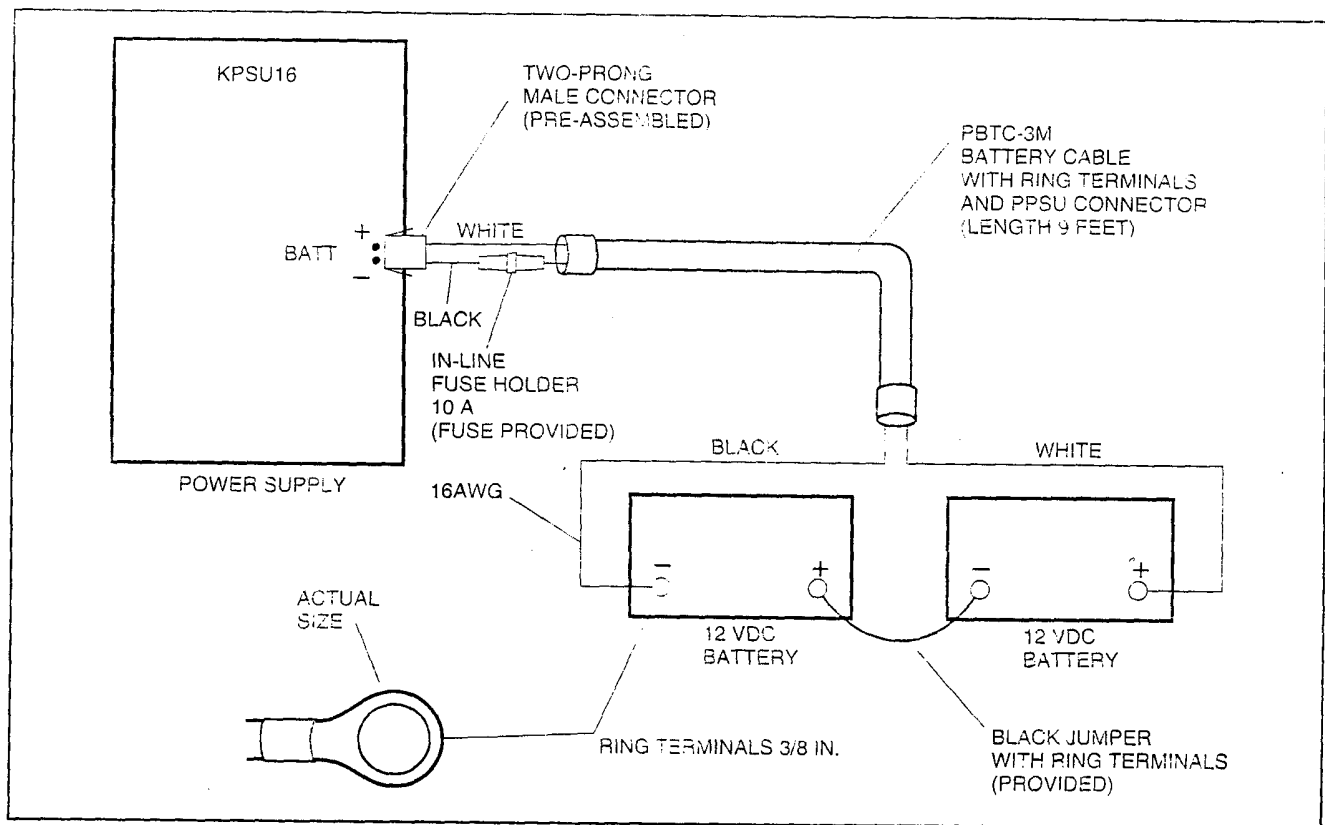
2.44 **Reserve Power Installation.** Install the Reserve Power option in accordance with the following steps (refer to Figure 5-9):

- 1) Connect the **PBTC-3M** black jumper wire from the positive terminal of one 12VDC battery to the negative terminal of the second 12VDC battery.
- 2) Ensure that a serviceable 10-ampere fuse is installed in the in-line fuse holder of the **PBTC 3M** battery cable.
- 3) Connect the white lead of the **PBTC-3M** battery cable to the open positive terminal of the 12VDC battery. Connect the black lead to the open negative terminal of the second 12VDC battery.

#### **IMPORTANT NOTE!**

**The KSU must be connected to the live operating (HOT) AC power source, and the power supply ON/OFF switch set to ON prior to the final step of connecting the reserve power batteries to the power supply via the BATT +/- receptacle. If the batteries are connected after AC power is lost, reserve power will not function.**

- 4) Connect the **PBTC-3M** battery cable two-prong male plug to the power supply BATT +/- receptacle.
- 5) To test reserve power operation, disconnect the system AC power plug with the power supply power **ON/OFF** switch in the **ON** position. The system should continue to operate without any interruption.



**FIGURE 5-9  
RESERVE POWER/BATTERY WIRING**

### 3 POWER SUPPLY REMOVAL AND REPLACEMENT

**3.00** The power supply (KSPU 16) comes factory-installed in the Base Key Service Unit (Figure 5-10); if necessary, it can be removed and replaced.

#### 3.10 Power Supply Removal

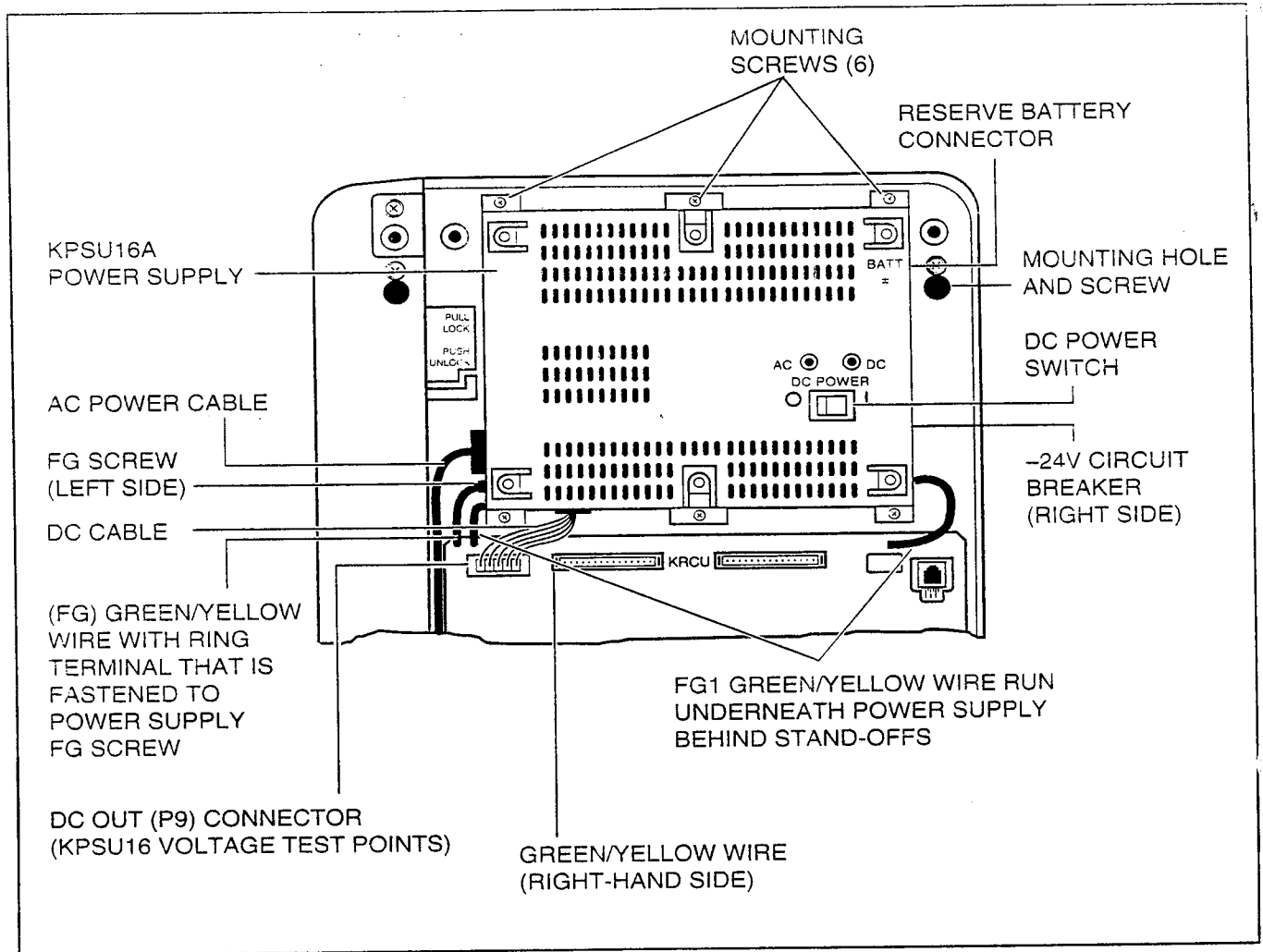
- 1) Make sure that the power supply switch is OFF and that the AC power cable is not plugged into an outlet. Confirm that green AC LED is not lit.
- 2) Unplug reserve battery cable from BATT connector of power supply (Figure 5-10).
- 3) Remove K4RCU PCB and Expansion Unit
- 4) Unplug the DC cable from the DC OUT connector (see Figure 5-10).

- 5) Remove FG screw from left side of power supply to free FG wire/terminal and building ground wire.

- 6) Remove the six screws that attach the power supply to the Base Key Service Unit. Remove power supply.

#### 3.20 Power Supply Replacement

- 1) Route FG1 wire (soldered on both sides of Base Unit motherboard) so it will be under the power supply inside of standoffs (see Figure 5-10).
- 2) Set the power supply in its proper place in the Base Key Service Unit (see Figure 5-9).
- 3) Secure the power supply to the Base Key Service Unit with the six screws.



**FIGURE 5-10**  
**POWER SUPPLY (KPSU16)**

- 4) Plug the DC cable into the DC OUT connector. Green/yellow wire is on right-hand side (Figure 5-10).
- 5) Fasten FG green/yellow wire ring terminal and building ground wire to the left side of the power supply with the FG screw.
- 6) Re-install K4RCU PCB (if required).
- 7) Plug the AC power cable into an outlet and turn ON the power supply switch.
- 8) Refer to Paragraph 2.10 to confirm that the power supply is working properly.
- 9) Plug reserve battery cable into BATT connector of power supply (Figure 5-10).

## PART II. DK16 PRINTED CIRCUIT BOARD INSTALLATION

### 4 GENERAL

**4.01** This chapter provides procedures for installation of STRATA DK16 system printed circuit boards (PCBs) into the Base and Expansion units. This includes installation instructions, optional configuration information, and wiring and programming considerations for each PCB.

**4.02** Be sure the power supply has been tested, and the ground has been checked. (See Chapter 5, Section I for the power supply and Chapter 3 for grounding.)

**4.03** It is recommended to install the Base Unit option PCBs K4RCU and/or KSTU before mounting the Base KSU on the wall.

**4.04** Begin Expansion PCB installation only after completion of Expansion Unit installation (see Chapter 5, Section I).

### 5 DK16 PCB INSTALLATION CONSIDERATIONS

**5.01** The STRATA DK16 Base Unit comes standard with eight digital telephone circuits (ports) and four CO line circuits. The digital circuits are integrated into the motherboard, and the CO line circuits are on the KCOU which is attached to the P6 and P7 connectors on the motherboard. The common control unit, like the digital telephone circuits, is built into the motherboard.

#### 5.10 DK16 Base Unit PCBs

**5.11** The Base Unit can support an optional KSTU printed circuit board (PCB) which provides four standard telephone circuits (ports). In addition, a K4RCU PCB can be installed to receive DTMF tones, and detect busy tone for Automatic Busy Redial (ABR) operation.

#### 5.20 DK16 Expansion Unit PCBs

**5.21** The Expansion Unit can support a number of PCBs: it can support a PCOU which provides four

CO line circuits: one or two KCDUs which provide two CO line circuits and four digital telephone circuits (ports); a PDKU which provides eight digital telephone circuits (ports); a PEKU which provides eight electronic telephone circuits (ports); a PESU which provides two standard and four electronic telephone circuits (ports); a PSTU which provides eight standard telephone circuits (ports); and a PIOUS or PIOUS which both provide a port for a Station Message Detail Recording (SMDR) device, an interface for remote maintenance, and relay control options.

**5.22** The DK16 Expansion Unit does not come from the factory with any PCBs installed. Any of the PCBs listed above can fit into any of the unit's four universal slots; however, it is recommended that PCBs that support electronic or digital telephones be installed into Slots 04 and 05, because Slots 06 and 07 cannot support Off-hook Call Announce or Data Interface Units (DIUs).

Recommended PCB slot assignments:

- KCDU — Slot 04 and 05 (2 maximum)
- PDKU, PEKU, PESU, PSTU — Slot 04 (1 maximum, cannot be installed with KCDU.)
- PCOU — Slot 05 (1 maximum, cannot be installed with KCDU.)
- PIOUS/PIOUS — Slot 06 (1 maximum)

#### 5.30 PCB Option Considerations

**5.31** PCBs may be configured for a variety of hardware and software options. Hardware options are defined as either internal (generally related to optional PCB subassemblies) or external (related to connection of peripheral equipment such as background music, voice mail, etc). Hardware and software options for each PCB are identified in the individual PCB installation procedures in this chapter.

**5.32 PCB Hardware Options.** Each PCB must be configured for the applicable hardware options prior to installation of the PCB. Configuration instructions for internal hardware options are provided in the individual PCB installation procedures in this chapter. Configuration instructions for external hardware options are provided in Peripheral Installation, Section 100-816-207.

**5.33 PCB Software Options.** PCBs are configured for software options through programming, after installation of the PCBs in the KSU. A programming overview for each PCB is provided in the individual PCB installation procedures in this chapter. Refer to the Programming Procedures, Section 100-816-300, for detailed programming instructions.

**5.40 PCB Installation/Power Supply Considerations**

**5.41** Whenever removing or installing PCBs it is recommended that the power supply be OFF.

**6 BASE UNIT STANDARD TELEPHONE INTERFACE UNIT (KSTU)**

**6.00 General**

**6.01** The optional KSTU provides four standard telephone circuits and it can only be installed in the Base Unit. The KSTU supports the two-wire devices such as standard telephones, Auto Attendant devices, voice mail machines, and facsimile machines. The KSTU can also support an alternate Background Music (BGM) source on circuit 4.

**NOTE:**

*For the system to recognize the Dual-Tone Multi-Frequency (DTMF) tones generated by standard telephones (or any other device connected to a KSTU port), a K4RCU must be installed in the Base Unit.*

**6.02** The KSTU is shown in Figure 5-11 and its connectors and controls are described in Table 5-A.

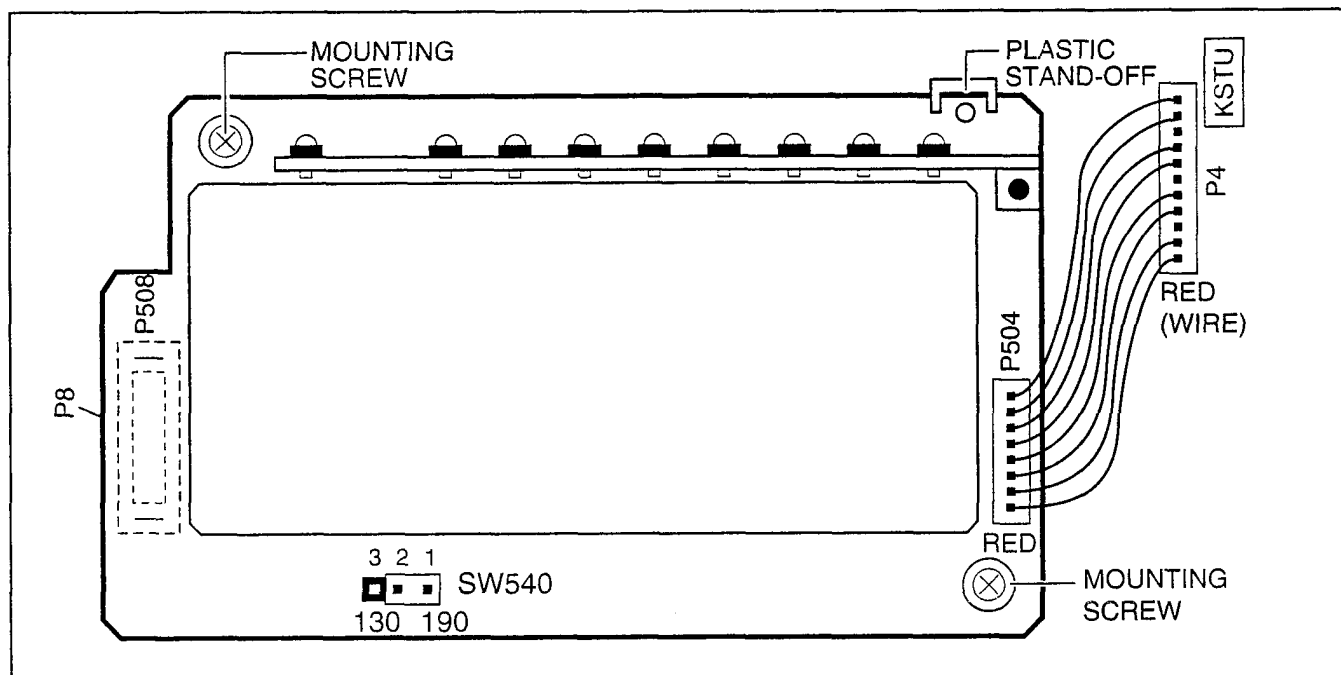
**6.10 KSTU Configuration**

**6.11** The KSTU only has to be configured for the ring generator voltage level, nothing else. Before installing the KSTU in the Base Unit, set the **SW540** ring generator to 130V P-P or 190V P-P. Most standard telephones and two-wire devices require 190; however, some devices may experience ring-trip at 190, and should be set at 130.

**6.20 KSTU Installation Procedure**

**6.21** Install the KSTU in accordance with the following steps:

- 1) Make sure that the power supply switch is OFF.



**FIGURE 5-11  
 KSTU OPTIONS AND CONNECTORS**

**TABLE 5-A**  
**KSTU CONTROLS AND INTERFACE CONNECTORS**

CONTROL/INDICATOR/ CONNECTOR (Figure 5-11)	TYPE OF COMPONENT	DESCRIPTION
Ring Voltage Jumper Plug SW540	Three-terminal jumper	Sets ring generator voltage level for all circuits: H = 190V P-P L = 130V P-P
Connector P508	Female Connector	Mates to male connector P8 on the motherboard.
Connector Cable P504	Cable	Connects to P4 connector on the motherboard.

- 2) Plug the KSTU cable into the **P4** connector on the motherboard in the Base Unit. The red wire on the cable should match up with pin 1 on the lower side of the connector.
- 3) Plug the KSTU **P508** female connector into the **P8** male connector on the motherboard.
- 4) Secure the KSTU to the standoffs with the two provided screws.

### 6.30 KSTU Wiring

**6.31** Refer to Base Unit Wiring in Section **100-816-208** for KSTU wiring.

**6.32** The KSTU must be connected to a OL13A (or equivalent) type lines for off-premises stations. (300 ohms loop resistance max., including the telephone or other devices DC off hook resistance.

### 6.40 KSTU Programming Overview

**6.41** The following parameters may be specified for the KSTU:

#### Program 03

- Specify code 31 for KSTU slot.

#### Program 31

- Used to configure all KSTU ports connected to voice mail (see Chapter 7 for voice mail installation).

#### Program 10-2

- Used to set standard telephone ringing option.

- Not required for Background Music (BGM) connection.

#### Program 19

- Used for BGM connection to KSTU Port 11.

#### NOTE:

*KSTU Ports (08~11) are fixed. They are assigned even if a KSTU is not installed.*

## 7 DIGITAL TELEPHONE INTERFACE UNIT (PDKU)

### 7.00 General

**7.01** The Digital Telephone Interface Unit (PDKU) provides eight ports/circuits for digital telephones and it can only be installed in the Expansion Unit. The PDKU can also support Integrated Data Interface Units (PDIU-DIs/PDIU-DI2s), Stand-alone Data Interface Units (PDIU-DSs), a Digital Door Phone/Lock Control Unit (DDCB), a Digital Direct Station Selection Console (DDSS), and Add-on Modules (ADMs). The DDSS console, DDCB, and PDIU-DSs are wired directly to the PDKU and require no additional hardware, but do require their own dedicated ports/circuits. The PDIU-DI/PDIU-DI2 or the ADM shares with its accompanying digital telephone the same wire pair and circuit on the PDKU. The PDKU (Figure 5-12) has no controls.

**NOTE:**

The PDIU-DI attaches to 1000-series Digital Telephones, and the PDIU-DI2 attaches to 2000-series Digital Telephones.

### 7.10 PDKU Hardware Options

7.11 The PDKU supports the hardware options noted below. Unlike the other PCBs, there are no controls on the PDKU that need to be set for options.

**Internal option:**

- none

**External option:**

- DDSS console
- PDIU-DS
- PDIU-DI/PDIU-DI2
- DDCB

**NOTE:**

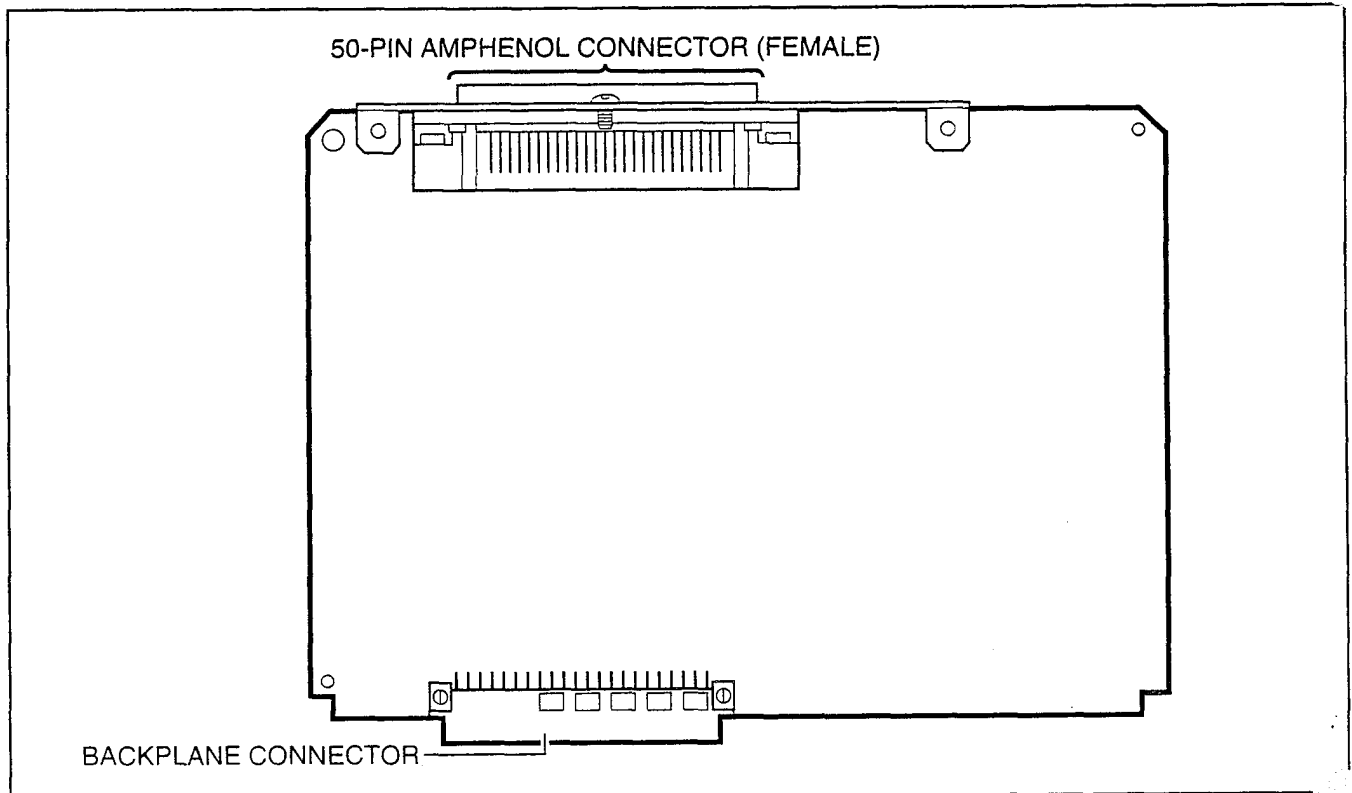
There are two versions of the PDKU: PDKU1,

and PDKU2. These versions are identical, except for the number of Data Interface Units (DIUs) they can support (see Paragraphs 7.14 and 7.15). Also, PDKU2 supports continuous DTMF tones with 2000-series digital telephones, but PDKU1 does not support continuous DTMF tones.

### 7.12 Hardware Configuration

**7.13 DDSS Console Configuration.** Refer to Station Apparatus Installation, Section 100-816-206, for installation procedures for the DDSS console. The DDSS console requires dedicated use of Circuit 8 of the PDKU.

**7.14 PDIU-DS Configuration.** Refer to Peripherals Installation, Section 100-816-207, for installation procedures for the PDIU-DS. A PDIU-DS can be connected to Circuits 1 ~ 7 on a PDKU1 or Circuits 1 ~ 8 on a PDKU2; the circuit must be dedicated to the PDIU-DS.



**FIGURE 5-12**  
**PDKU INTERFACE CONNECTION**



**7.15 PDIU-DI/PDIU-DI2 Configuration.** Refer to Station Apparatus Installation, Section **100-816-206**, and Peripherals Installation, Chapter 7, for installation procedures for the PDIU-DI/PDIU-DI2. PDIU-DIs/PDIU-DI2s can be equipped with any digital telephone connected to PDKU Circuits 1 ~ 7 with PDKU1 or Circuits 1 ~ 8 with PDKU2.

**7.16 DDCB Configuration.** Refer to Peripherals Installation, Section **100-816-207**, for installation procedures for the DDCB. The DDCB must be connected to the Circuit 8 on the PDKU.

**7.17 ADM Configuration.** Refer to Section **100-816-206**, Paragraph 7.00.

### 7.20 PDKU Installation Procedure

**7.21** Install the PDKU in accordance with the following steps:

- 1) Remove the PCB from its protective packaging.
- 2) Insert the PDKU into the appropriate slot (see Paragraph 5.22, and apply firm, even pressure to ensure proper mating of connectors.

**NOTE:**

*Ensure the PDKU's component side is facing right when installing it in the KSU.*

- 4) After installing the PDKU, gently pull the PCB outward. If the connectors are properly mated, a slight resistance will be felt.

### 7.30 PDKU Wiring

**7.31** Refer to PDKU Wiring Diagrams, Chapter 8, for wiring/interconnecting details.

### 7.40 PDKU Programming Overview

**7.41** The following parameters may be specified, through programming, for the PDKU:

#### Program 03

- Specify code 61 if no options are installed on a PDKU.
- Specify code 62 to indicate a PDKU that will support stations that must receive Off-hook Call Announce (OCA).
- Specify code 64 to indicate a PDKU configured for a DDSS console and OCA.

#### Programs 20, 21, and 22

- Use to configure PDIU-DIs/PDIU-DI2s and PDIU-DSs.

#### Programs 28 and 29

- Use for DDSS assignments.

#### Program 30

- Adjusts initial off-hook volume level for digital telephone handsets.

#### Program 92-5

- Initializes initial ringing, speaker, and muted ring volume levels of digital telephones.

#### Programs 77-1, 77-2, and 79

- Used for DDCB and door phone assignments

## 8 ELECTRONIC TELEPHONE INTERFACE UNIT (PEKU)

### 8.00 General

**8.01** The Electronic Telephone Interface Unit (PEKU) provides eight ports for electronic telephones and it must be installed in the Expansion Unit. It is recommended that the current 6500-series be used, because this series consumes the least amount of power.

**8.02** The PEKU can be configured to receive Off-hook Call Announce (OCA) by installing an Off-hook Call Announce Unit (EOCU). It can also be configured to support an HDSS console and an external Background Music (BGM) source connector. An external amplifier for two-CO line conference calls can also be connected to Circuits 6 and 7 of the PEKU. The HDSS console, the external amplifier, and the BGM source, are wired directly to the PEKU and require no additional hardware, but do require specific ports/circuits. Electronic telephones also wire directly to the PEKU, and they can be connected to any PEKU circuit.

**8.03** PEKU controls and interface connectors are shown in Figure 5-13 and described in Table 5-B.

### 8.10 PEKU Hardware Options

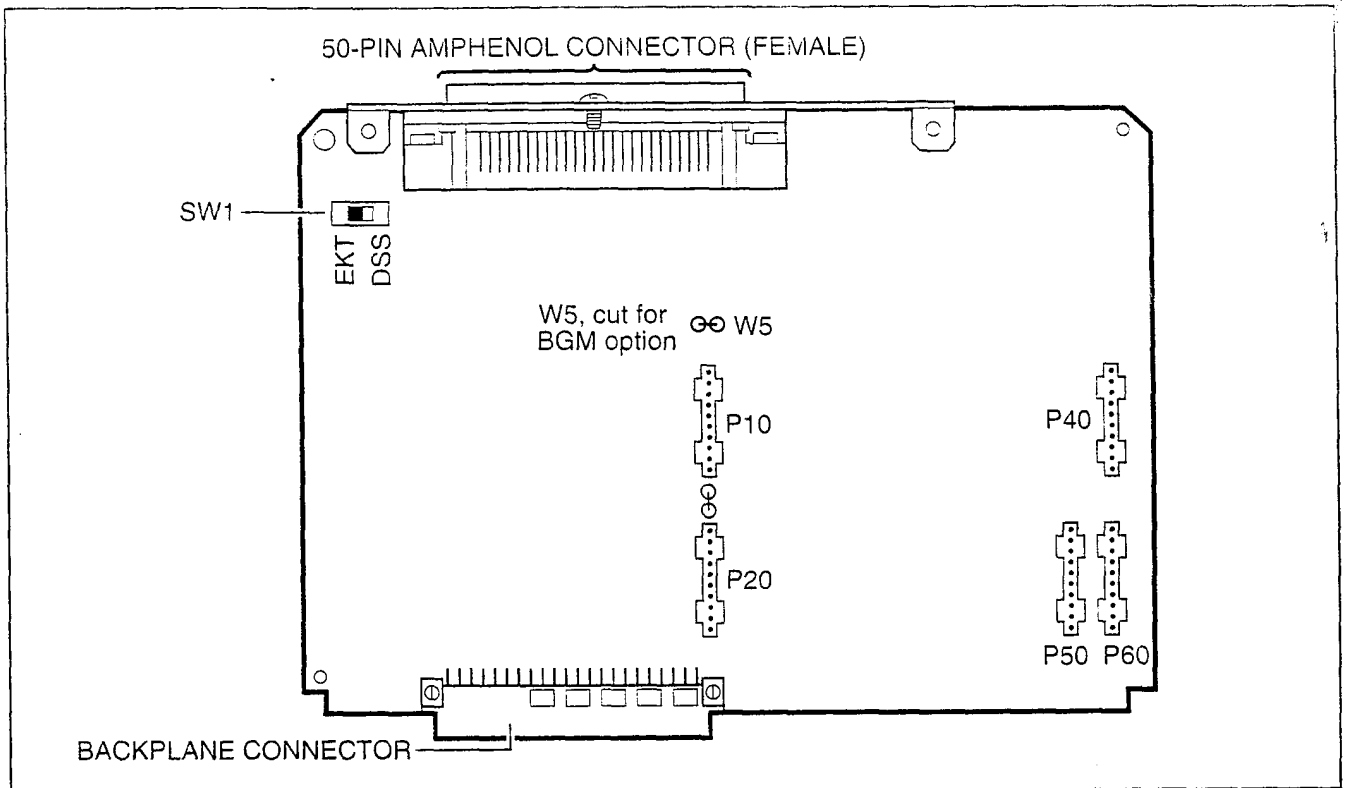
**8.11** The PEKU supports the following hardware options:

#### Internal Options

- Off-hook Call Announce Unit (EOCU)

#### External Options

- HDSS console
- BGM source connection
- External Amplifier



**FIGURE 5-13**  
**PEKU CONTROLS AND INTERFACE CONNECTORS**

**8.12 Off-hook Call Announce (EOCU) Installation.** Install the Off-hook Call Announce Unit (EOCU) in accordance with the following steps:

- 1) Remove the PCB from its protective packaging.

**NOTE:**

*PEKU connectors P10, P20, P40, P50, and P60 are positioned to allow installation of the EOCU only in the proper position (Figure 5-13).*

- 2) Mate EOCU connectors J10, J20, J40, J50, and J60 with PEKU connectors P10, P20, P40, P50, and P60 (Figure 5-14).
- 3) Apply firm, even pressure to EOCU to ensure proper mating of connectors.
- 4) Use a 3-pair cable for making connections between the PEKU and the Off-hook Call Announce (OCA) electronic telephone. Refer to Wiring Diagrams, Section 100-816-208, for wiring/interconnecting details.

- 5) Refer to Station Apparatus Installation, Section 100-816-206, for procedures to upgrade electronic telephones for OCA.

**8.13 HDSS Console Configuration.** Configure the PEKU to support an HDSS console in accordance with the following steps:

- 1) Remove the PCB from its protective packaging.
- 2) Set the SW1 DSS/EKT switch to DSS.
- 3) Refer to Station Apparatus Installation, Section 100-816-206, for installation procedures for the HDSS console. The HDSS console requires dedicated use of Circuits 7 and 8 of the PEKU PCB.

**8.14 Background Music (BGM) Configuration.** Configure the PEKU to support a BGM source in accordance with the following steps:

- 1) Remove the PCB from its protective packaging.

TABLE 5-B  
PEKU CONTROLS AND INTERFACE CONNECTORS

CONTROL/INDICATOR/ CONNECTOR (Figure 5-13)	TYPE OF COMPONENT	DESCRIPTION
Off-hook Call Announce P10	10-pin connector	Interface connector for optional Off-hook Call Announce subassembly connector (used in conjunction with P20, P40, P50, and P60).
Off-hook Call Announce P20	10-pin connector	Interface connector for optional Off-hook Call Announce subassembly connector (used in conjunction with P10, P40, P50, and P60).
Off-hook Call Announce P40	10-pin connector	Interface connector for optional Off-hook Call Announce subassembly connector (used in conjunction with P10, P20, P50, and P60).
Off-hook Call Announce P50	10-pin connector	Interface connector for optional Off-hook Call Announce subassembly connector (used in conjunction with P10, P20, P40, and P60).
Off-hook Call Announce P60	10-pin connector	Interface connector for optional Off-hook Call Announce subassembly connector (used in conjunction with P10, P20, P40, and P50).
DSS/EKT DSS Console/ Electronic Telephone SW1 Switch	Two-position slide switch	Configures PEKU for operation with either an HDSS console or electronic telephones.
BGM source connection W5 Jumper Wire	White jumper wire	When cut, configures PEKU for BGM source connection.

2) Cut the **W5** (BGM) jumper wire on the PEKU PCB.

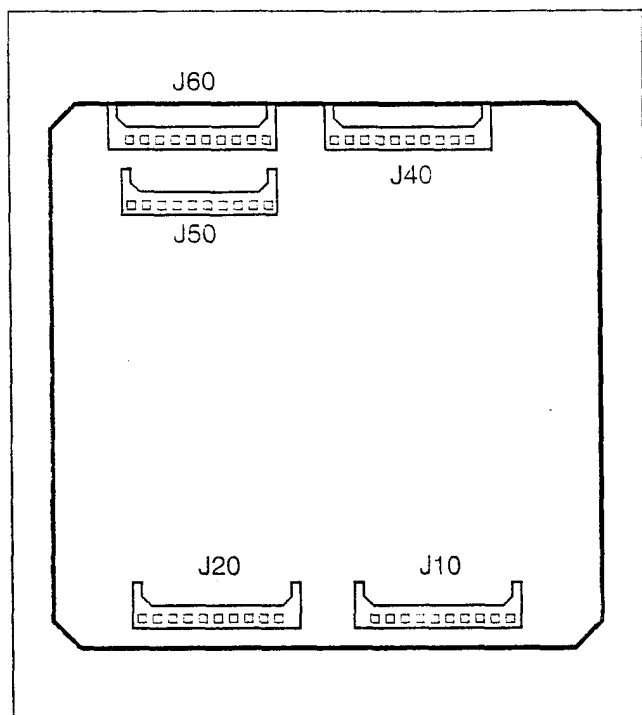
3) Refer to Peripherals Installation, Section **100-816-207**, for installation procedures for BGM connection.

**8.15 External Amplifier Configuration.** The PEKU does not have to be configured to support an external amplifier. However, the system must be programmed for one; see Paragraph **8.40**. See Peripherals Installation, Section **100-816-207**, for external amplifier installation instructions.

## 8.20 PEKU Installation Procedure

**8.21** Install the PEKU in accordance with the following steps:

- 1) Remove the PCB from its protective packaging.
- 2) Ensure the PEKU has been configured for the appropriate hardware options (refer to Paragraph **8.10**).
- 3) Insert the PEKU into the appropriate slot (refer to Paragraph **5.22**), and apply firm, even



**FIGURE 5-14**  
**OFF-HOOK CALL ANNOUNCE UNIT (EOCU)**  
**INTERFACE CONNECTORS**

pressure to ensure proper mating of connectors.

- 4) After installing the PEKU, gently pull the PCB outward. If the connectors are properly mated, a slight resistance will be felt.

### 8.30 PEKU Wiring

8.31 Refer to PEKU Wiring Diagrams, Section 100-816-208, for wiring/interconnecting details.

### 8.40 PEKU Programming Overview

8.41 The following parameters may be specified, through programming, for the PEKU:

#### Program 03

- Specify code 21 to indicate a station line PEKU.
- Specify code 22 to indicate a PEKU configured for OCA.
- Specify code 23 to indicate a PEKU configured for an HDSS console.

- Specify code 24 to indicate a PEKU configured for OCA and an HDSS console.

#### Program 10-2

- Used for BGM connection.

#### Program 10-3

- Used for external amplifier connection.

#### Program 19

- Also used for BGM connection.

#### Programs 28 and 29

- Used for HDSS assignments.

## 9 STANDARD TELEPHONE INTERFACE UNIT (PSTU)

### 9.00 General

9.01 The Standard Telephone Interface Unit (PSTU) provides an interface between standard telephones or two-wire devices and the system, and it must be installed in the Expansion Unit. The PSTU PCB adds eight standard telephone lines to the system. The PSTU can also support a Background Music (BGM) source.

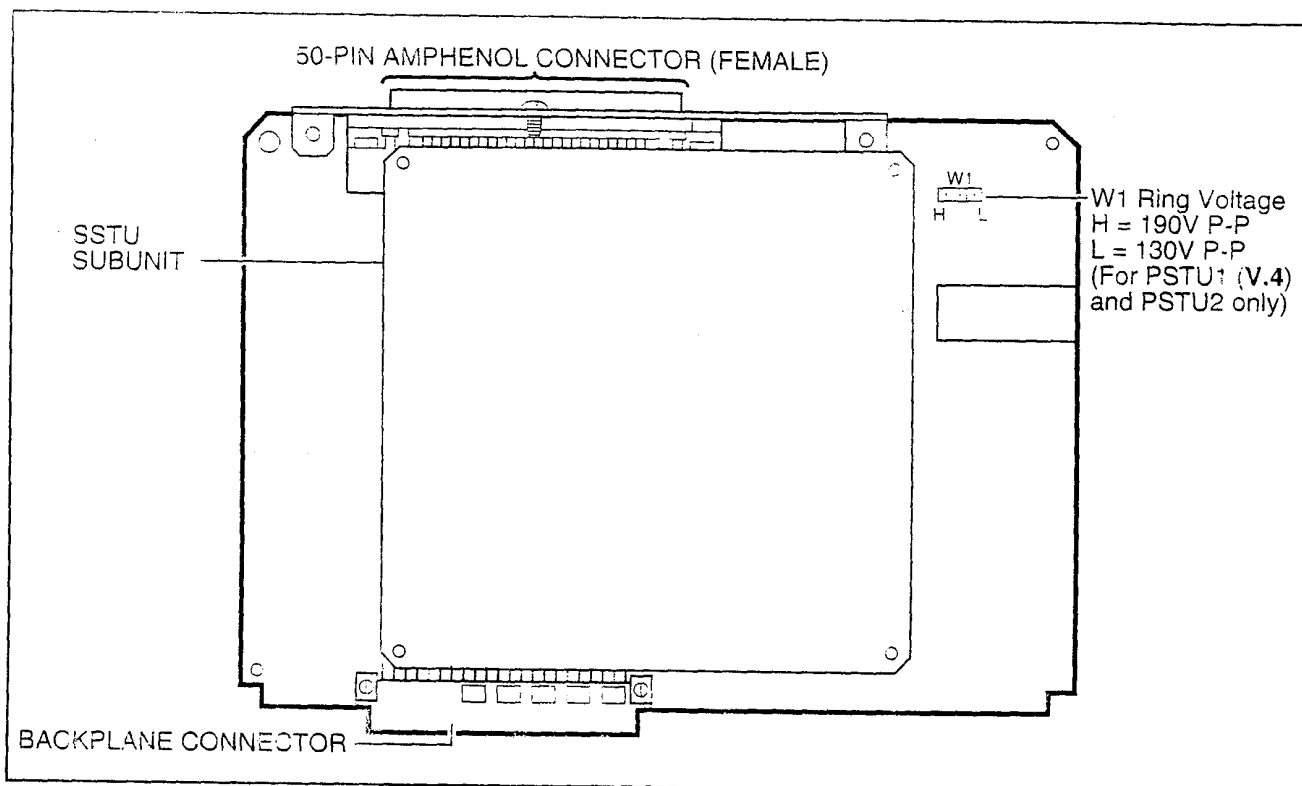
#### NOTE:

*For the system to recognize the Dual-Tone Multi-Frequency (DTMF) tones generated by a standard telephone (or any other device connected to a PSTU port), a DTMF Receiver Unit (K4RCU) must be installed in the Base Unit.*

9.02 PSTU controls are shown in Figure 5-15 and described in Table 5-C.

### 9.10 PSTU (1 and 2) Hardware Options

9.11 There are two PSTU versions (1 and 2): They are identical except for the ring generator. The ring generator on the original version (V.3) of PSTU1 is fixed at a 190V P-P level, while the ring generator on PSTU1 (V.4) and PSTU2 can be set for 130V P-P or 190V P-P. The W1 jumper plug is used to set the voltage level. Most standard telephones and two-wire devices require the 190V P-P level; however, some devices may experience ring-trip with 190V P-P and they require the 130V P-P level.



**FIGURE 5-15  
PSTU AND SUBUNIT (SSTU)**

**TABLE 5-C  
PSTU CONTROLS AND INTERFACE CONNECTORS**

CONTROL/INDICATOR/ CONNECTOR (Figure 5-15)	TYPE OF COMPONENT	DESCRIPTION
Ring Voltage W1 Jumper Plug (PSTU1 (V.4) and PSTU2 only)	Three-terminal jumper	Sets ring generator voltage level for all circuits. H = 190V P-P L = 130V P-P

**NOTE:**  
*PSTU1 (V.4) became available in November 1989. PSTU1(V.3) was discontinued.*

**9.12** Set the PSTU1 (V.4) or PSTU2 ring generator level as required:

- **W1** set to H (190V P-P).
- **W1** set to L (130V P-P).
- Two ringers maximum per port (H or L).

**9.13** Unlike the PEKU or PESU, the PSTU does not have to be configured for BGM: There is no jumper wire to cut, etc.

**9.20 PSTU Installation Procedure**

**9.21** Install the PSTU in accordance with the following steps:

- 1) Remove the PCB from its protective packaging. The protective shield on the back of the PSTU is designed to protect the installer from

potentially hazardous ring voltage. Do not remove this shield.

- 2) Ensure that the PSTU subunit (SSTU) is securely attached to the PSTU (refer to Figure 5-15).

**NOTE:**

*W1. the ring generator level option, should be set in the H position (factory) for initial installation.*

- 3) Insert the PSTU into the appropriate slot (refer to Paragraph 5.22), and apply firm, even pressure to ensure proper mating of connectors.

### 9.30 PSTU Wiring

9.31 Refer to PSTU Wiring Diagram, Section 100-816-208, for wiring/interconnecting details.

9.32 The PSTU is registered for use with OL13A type lines for off-premises stations.

### 9.40 PSTU Programming Overview

9.41 The following parameters may be specified, through programming, for the PSTU:

**Program 03**

- Specify code 31 for all slots that have PSTUs installed.

**Program 31**

- Used to configure all PSTU ports connected to voice mail (Section 100-816-207 for more details).

**Program 10-2**

- Used to set standard telephone ringing option.
- Also used for BGM connection.

**Program 19**

- Used for BGM connection also.

## 10 STANDARD/ELECTRONIC TELEPHONE INTERFACE UNIT (PESU)

### 10.00 General

10.01 The Standard/Electronic Telephone Interface Unit (PESU) provides two standard telephone interface circuits (1 and 2) identical to PSTU circuits for connection between standard telephones, or

two-wire devices, and the system. It also provides four electronic telephone interface circuits (5 ~ 8) identical to PEKU circuits for connecting electronic telephones, BGM or an external amplifier. The PESU provides a ring generator for circuits 1 and 2 (with a ring voltage of either 190V P-P or 130V P-P), and it must be installed in the Expansion Unit.

- The PESU does not support an HDSS console connection.
- The PESU provides connectors to mount the EOCU for OCA to electronic telephones.

**NOTE:**

*A KSU must be installed in the Base Unit for the system to recognize Dual-Tone Multi-Frequency (DTMF) tones sent from standard telephones or other two-wire devices that are connected to the PESU.*

10.02 The PESU controls and interface connectors are shown in Figure 5-16 and described in Table 5-D.

### 10.10 PESU Hardware Options

10.11 The PESU supports the following hardware options:

- **Internal option:** Off-hook Call Announce (EOCU).

**NOTE:**

*Refer to Section 100-816-206 and Section 100-816-207 for installation of external options.*

10.12 **Off-hook Call Announce (EOCU) Installation.** Install the Off-hook Call Announce in accordance with the following steps:

- 1) Remove the PCB from its protective packaging.

**NOTE:**

*PESU connectors P10, P20, P40, P50, and P60 are positioned to allow installation of the EOCU only in the proper position (refer to Figure 5-16).*

- 2) Mate the EOCU connectors J10, J20, J40, J50, and J60 with the PESU connectors P10, P20, P40, P50, and P60 (refer to Figure 5-16).

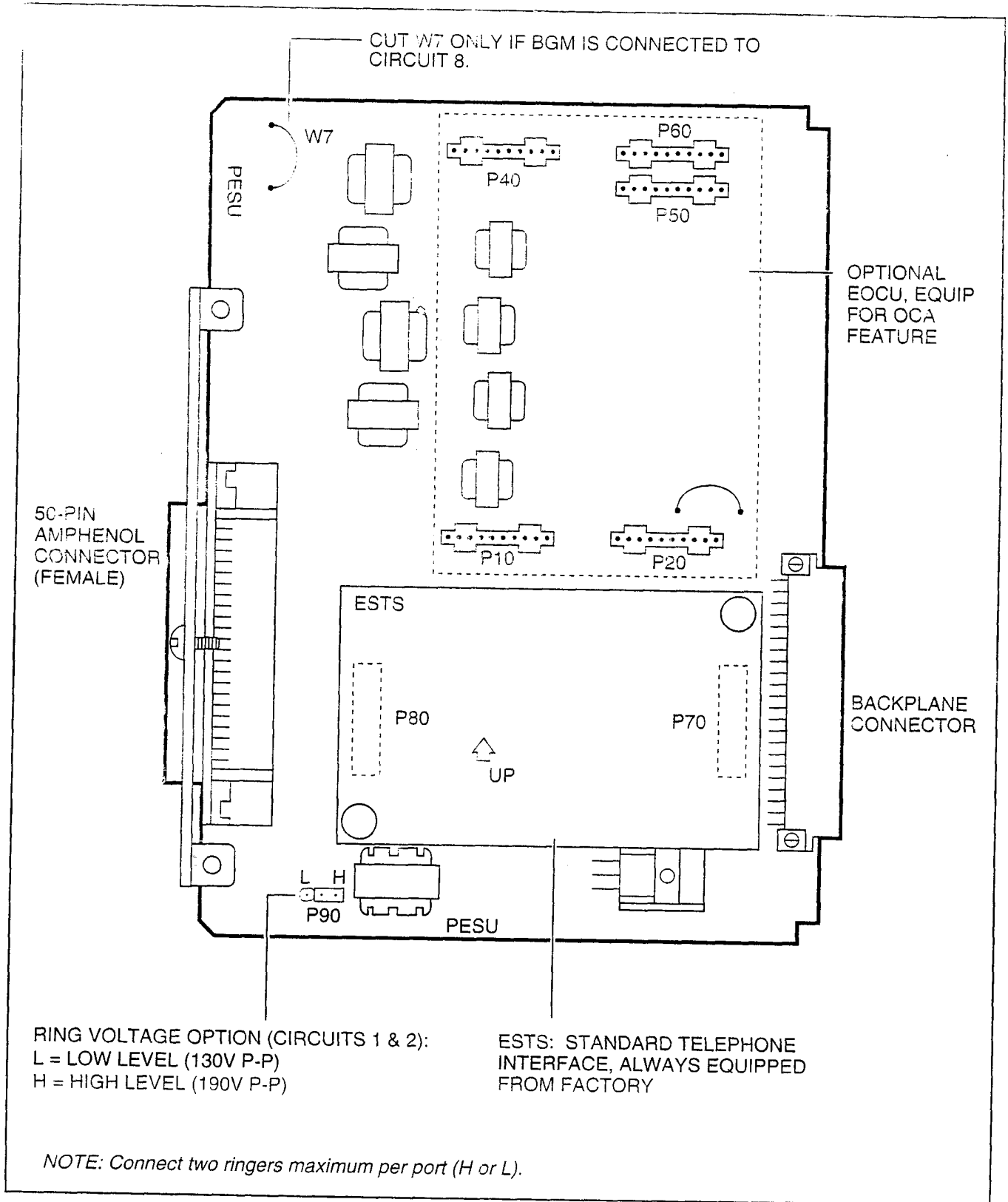


FIGURE 5-16  
 PESU PCB OPTION LOCATION AND IDENTIFICATION

**TABLE 5-D  
PESU CONTROLS AND INTERFACE CONNECTORS**

CONTROL/INDICATOR/ CONNECTOR (Figure 5-16)	TYPE OF COMPONENT	DESCRIPTION
Off-hook Call Announce P10	10-pin connector	Interface connector for optional Off-hook Call Announce subassembly connector (used in conjunction with P20, P40, P50, and P60).
Off-hook Call Announce P20	10-pin connector	Interface connector for optional Off-hook Call Announce subassembly connector (used in conjunction with P10, P40, P50, and P60).
Off-hook Call Announce P40	10-pin connector	Interface connector for optional Off-hook Call Announce subassembly connector (used in conjunction with P10, P20, P50, and P60).
Off-hook Call Announce P50	10-pin connector	Interface connector for optional Off-hook Call Announce subassembly connector (used in conjunction with P10, P20, P40, and P60).
Off-hook Call Announce P60	10-pin connector	Interface connector for optional Off-hook Call Announce subassembly connector (used in conjunction with P10, P20, P40, and P50).
Ring Voltage Jumper Plug P90	Three-terminal jumper	Sets ring generator voltage level for circuits 1 and 2. H = 190V P-P (factory setting) L = 130V P-P
BGM W7 Jumper Pack	White jumper wire	When cut, configures PESU, circuit 8, for BGM source connection.

- 3) Apply firm, even pressure to the EOCU to ensure proper mating of connectors.
- 4) Use 3-pair cable for connecting the PESU and the OCA electronic telephone (refer to Wiring Diagrams, Section 100-816-208, for wiring/interconnecting details).
- 5) Refer to Station Apparatus Installation, Section 100-816-206, for procedures to add OCA to electronic telephones.

**10.13 Background Music (BGM) Configuration.** Configure the PESU to support a BGM source in accordance with the following steps:

- 1) Remove the PCB from its protective packaging.
- 2) Cut the W7 (BGM) jumper wire on the PESU PCB.
- 3) Refer to Peripherals Installation, Section 100-816-207, for BGM installation procedures.

**10.14 External Amplifier Configuration.** The PESU does not have to be configured to support an



external amplifier. However, the system must be programmed for one; see Paragraph 10.40. The external amplifier requires Circuits 6 and 7 on the PESU. See Peripherals Installation, Section 100-816-207, for external amplifier installation instructions.

### 10.20 PESU Installation Procedure

10.21 Install the PESU in accordance with the following steps:

- 1) Remove the PCB from its protective packaging. The protective shield on the back of the PESU is designed to protect the installer from potentially hazardous ring voltage. Do not remove this shield.
- 2) Ensure that the PESU subunit (ESTS) is securely attached to the PESU (refer to Figure 5-15).
- 3) If the electronic telephones connected to the PESU must receive OCA calls, install the EOCU subassembly PCB on the PESU per Paragraph 10.12.
- 4) If a BGM source is connected to the PESU, Circuit 8, cut **W7**.
- 5) Ensure that the ring voltage option, **P90**, is set to the "H" position for initial installation. The "L" position is used if devices connected to the PESU trip ring voltage before answer.
- 6) Insert the PESU into the appropriate slot, and apply firm, even pressure to ensure proper mating of connectors.
- 7) After installing the PESU, gently pull the PCB outward. If the connectors are properly mated, a slight resistance will be felt.

### 10.30 PESU Wiring

10.31 Refer to PESU Wiring Diagram, Section 100-816-208, for wiring/interconnecting details.

### 10.40 PESU Programming Overview

10.41 The following parameters may be specified, through programming, for the PESU:

#### Program 03

- Specify code 25 for all slots that have PESUs without EOCU.
- Specify code 26 for all slots that have PESUs equipped with EOCU.

*NOTE:*

*A special code is not required to connect BGM to a PESU.*

#### Program 31

- Configures the PESU Circuits 1 and 2 for connection to voice mail devices.

#### Program 10-2

- Sets the standard telephone ring cadence for normal or distinctive ringing and BGM source connection.

#### Program 10-3

- Used for external amplifier connection.

#### Program 19

- Also used for BGM connection.

## 11 CO LINE UNIT (PCOU)

### 11.00 General

11.01 The PCOU PCB adds four CO lines to the system and it can only be installed in the Expansion Unit. The PCOU provides Ring Detection, Dial Outpulsing and Hold; as well as Automatic Busy Redial (ABR) circuitry. Each CO line can be programmed for Dual-Tone Multi-Frequency (DTMF) or dial pulse.

*NOTE:*

*There are two PCOU versions (1 and 2). They are identical in fit/form/function and are interchangeable in all DK system models.*

11.02 PCOU controls, indicators, and interface connectors are shown in Figure 5-17 and described in Table 5-E.

### 11.10 PCOU Hardware Options

11.11 There are no hardware options supported by the PCOU.

### 11.20 PCOU Installation Procedure

11.21 Install the PCOU in accordance with the following steps:

- 1) Remove the PCB from its protective packaging.

**NOTE:**

The dB PAD switches **SW101** through **SW401** control excessive loudness resulting from close proximity to the CO or PBX telephone office by providing a 3 decibel (dB) signal level drop to, or from, the PBX or CO when set to the 3 position. Switches are factory-set to the 0 (0 dB signal level drop) position.

- 2) If the Expansion Unit is located within one mile of the PBX or CO telephone office, set dB PAD switches **SW101** through **SW401** to the 3 (-3 dB signal level drop) position.
- 3) Insert the PCOU into the appropriate slot (refer to Paragraph 2.22), and apply firm, even pressure to ensure proper mating of connectors.
- 4) After installing the PCOU, gently pull the PCB outward. If the connectors are properly mated, a slight resistance will be felt.

### 11.30 PCOU Wiring

11.31 Refer to PCOU Wiring Diagram, Section 100-816-208, for wiring/interconnecting details.

### 11.40 PCOU Programming Overview

11.41 The following parameters may be specified, through programming, for the PCOU:

**Program 03**

- Specify code 11 for the slot in which the PCOU is installed.

**Program 10-1**

- Allows/denies two-CO Line Conference and Direct Inward System Access (DISA).

**Program 15**

- Assigns DTMF/Dial Pulse (DP) Dialing, Tenant Service, DISA, and other attributes to each CO line.

**Program 16**

- Assigns CO lines to groups 81 ~ 88, and dial 9 group.

**Program 40**

- Assigns stations access to CO lines (incoming and outgoing access).

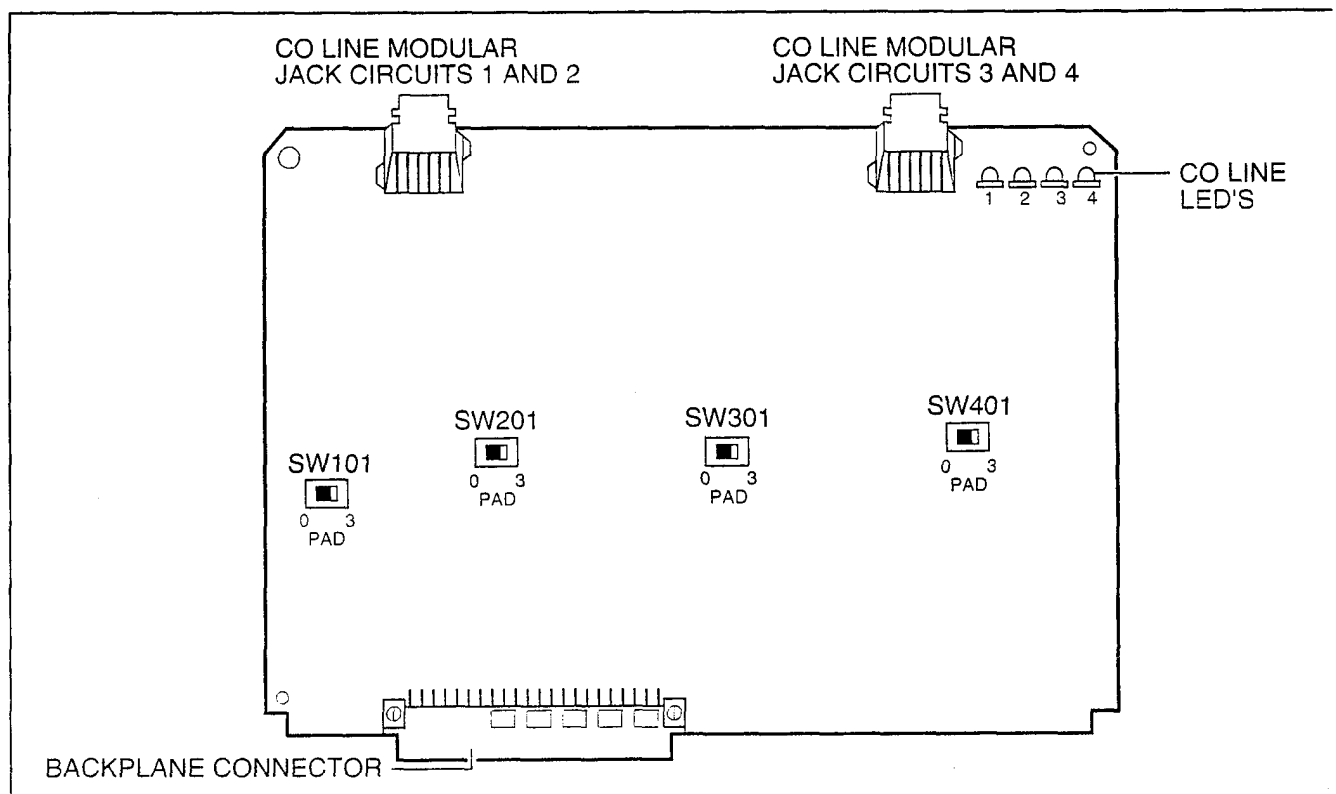


FIGURE 5-17  
 PCOU CONTROLS, INDICATORS, AND INTERFACE CONNECTORS

**TABLE 5-E  
 PCOU CONTROLS, INDICATORS, AND INTERFACE CONNECTORS**

CONTROL/INDICATOR/ CONNECTOR (Figure 5-17)	TYPE OF COMPONENT	DESCRIPTION
CO Line Circuit 1 Indicator CD112	Red LED	Lights to indicate CO line circuit 1 is in operation (NOTE: CO line indicator will not light unless PCOU is connected to a CO).
CO Line Circuit 2 Indicator CD212	Red LED	Lights to indicate CO line circuit 2 is in operation (NOTE: CO line indicator will not light unless PCOU is connected to a CO).
CO Line Circuit 3 Indicator CD312	Red LED	Lights to indicate CO line circuit 3 is in operation (NOTE: CO line indicator will not light unless PCOU is connected to a CO).
CO Line Circuit 4 Indicator CD412	Red LED	Lights to indicate CO line circuit 4 is in operation (NOTE: CO line indicator will not light unless PCOU is connected to a CO).
J1 Connector	Modular connector	Interface connector for CO line circuits 1 and 2.
J2 Connector	Modular connector	Interface connector for CO line circuits 3 and 4.
PAD Switch SW101	Two-position slide	Enables 3dB signal level drop for CO line circuit 1.
PAD Switch SW201	Two-position slide	Enables 3dB signal level drop for CO line circuit 2.
PAD Switch SW301	Two-position slide	Enables 3dB signal level drop for CO line circuit 3.
PAD Switch SW401	Two-position slide	Enables 3dB signal level drop for CO line circuit 4.

**Program 41**

- Assigns stations access to CO lines (outgoing only).

**Program 42-0, 1-8**

- Assigns behind PBX/CENTREX operation to each CO line.

**Programs 45 ~ 48**

- Defines Toll Restrictions for any CO line.

**Programs 50 ~ 56**

- Defines Least Cost Routing using CO lines.

**Program 78**

- Assigns special ringing of CO lines: Night Ring Over Page, DISA, IMDU.

**Programs 81 ~ 89**

- Assigns CO lines to ring selected stations.
- Assigns Delayed Ringing to any CO line.

**Program 93**

- Assigns names to CO lines.

## 12 OPTION INTERFACE UNIT (PIOU AND PIOUS)

### 12.00 General

**12.01** The Option Interface Unit (PIOU or PIOUS) provides a circuit interface with peripheral options. A maximum of one PIOU or PIOUS PCB can be installed in the system. The PIOU and PIOUS support the same options, except the PIOUS does not support Zone Paging (see Paragraph 12.11).

**12.02** PIOU controls, indicators, and interface connectors are shown in Figure 5-18 and described in Table 5-F. PIOUS information is provided in Figure 5-19 and Table 5-G.

**12.03** The internal 600 ohm or 3 watt page amplifier of the PIOU is not supported by Strata DK16.

### 12.10 PIOU and PIOUS Hardware Options

**12.11** The PIOU and PIOUS support the following STRATA DK16 hardware options:

#### Internal Options

- Remote Maintenance Modem Unit (IMDU)

#### External Options

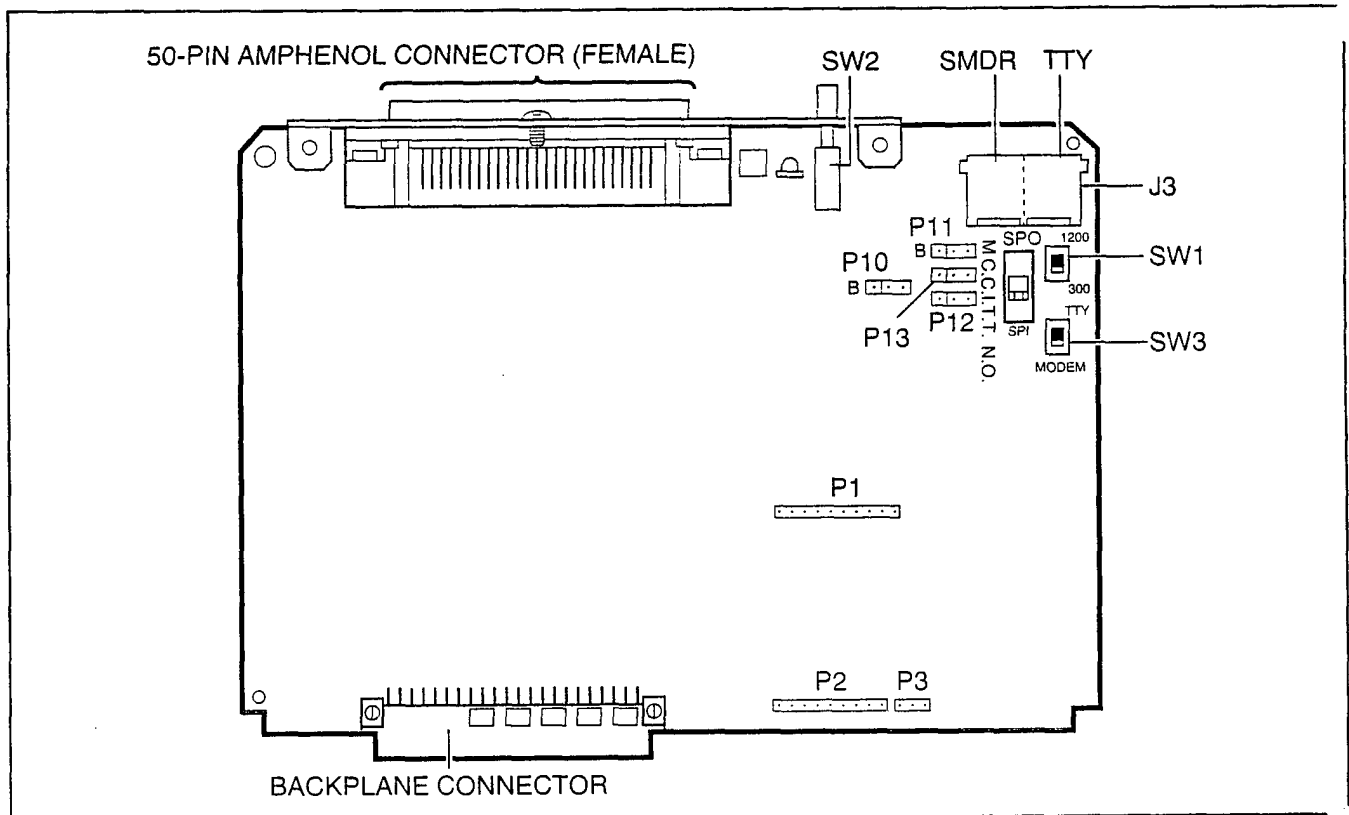
- Alarm Sensor
- Local Maintenance Terminal or Modem
- SMDR Printer or Call Accounting Port
- Remote Maintenance Port
- Relay control options
- Zone Page via relays (PIOU only)

#### NOTE:

*Refer to Peripheral Equipment Installation, Section 100-816-207, for installation of external options.*

**12.12 Remote Maintenance Modem Unit (IMDU) Installation.** Install the Remote Maintenance Modem Unit (IMDU) in accordance with the following steps:

- 1) Remove the PCB from its protective packaging.



**FIGURE 5-18**  
**PIOU CONTROLS, INDICATORS, AND INTERFACE CONNECTORS**

TABLE 5-F  
PIOU CONTROLS AND INTERFACE CONNECTORS

CONTROL/INDICATOR/ CONNECTOR (Figure 5-18)	TYPE OF COMPONENT	DESCRIPTION
SMDR/TTY interface Connector J3	Dual modular connector	Interface connector for SMDR printer/ call accounting device and maintenance terminal/modem.
IMDU Connector P1	10-pin connector	Interface connector for Remote Maintenance Modem piggy-back module.
IMDU Connector P2	9-pin connector	Interface connector for Remote Maintenance Modem piggy-back module.
IMDU Connector P3	3-pin connector	Interface connector for Remote Maintenance Modem piggy-back module.
M/B Make/Break Jumper Plug P10	Three-terminal jumper plug	External Page/Door Lock Control Relay MAKE or BREAK jumper plug.
M/B Make/Break Jumper Plug P11	Three-terminal jumper plug	Night/Hold Relay MAKE or BREAK jumper plug.
Alarm Sensor N.O./N.C. Jumper Plug P12	Three-terminal jumper plug	Alarm sensor normally open or normally closed jumper plug.
CCITT/BELL Jumper Plug P13	Three-terminal jumper plug	IMDU or external modem operating specification jumper plug.
SMDR Baud Rate Switch SW1	Two-position slide switch	Selects baud rate (300 or 1200 bps) for SMDR printer or call accounting device.
TTY Baud Rate Switch SW2	Two-position locking push- button switch	Selects baud rate (300 or 1200 bps) for Remote Maintenance Modem piggy-back module (IMDU) or external TTY jack.
Modem/TTY Switch SW3	Two-position slide switch	Enables PIOU for operation with IMDU modem or TTY jack.

- 2) Set the **SW2** baud rate switch on the front panel to **300** or **1200**, as appropriate, after the PIOU/PIOUS has been installed in the Expansion Unit (in-300 bps—out-1200 bps).
- 3) Set **SW3** to MODEM position for IMDU operation.
- 4) Set the **P13** jumper plug on the PIOU to the BELL position; or, cut the **W4** jumper on the PIOUS for BELL operation.
- 5) Mate IMDU connectors **J1**, **J2**, and **J3** with PIOU or PIOUS connectors **P1**, **P2**, and **P3** (refer to Figure 5-20).

**NOTE:**

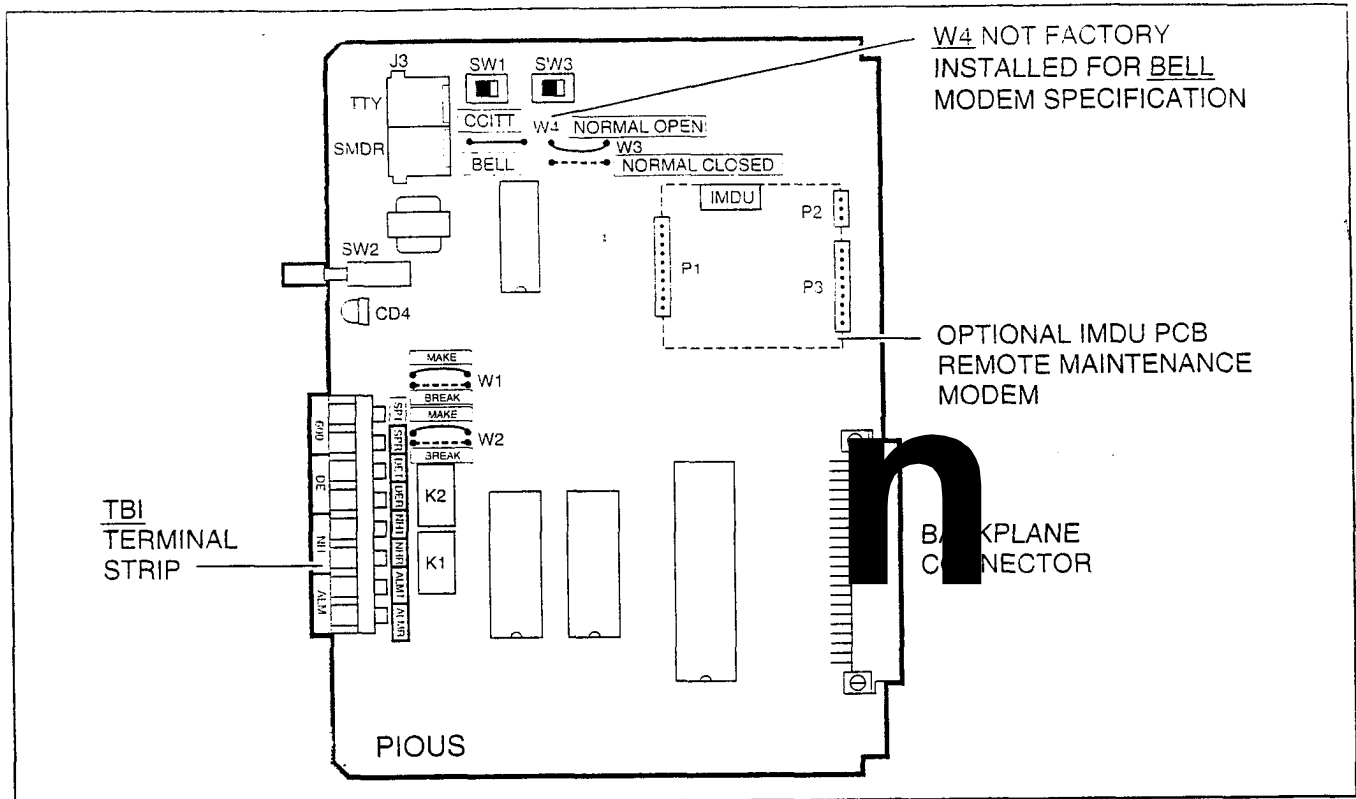
*PIOU or PIOUS connectors **P1**, **P2**, and **P3** are positioned to allow installation of the IMDU only in the proper position.*

- 6) Apply firm, even pressure to IMDU to ensure proper mating of connectors.

**NOTE:**

*The IMDU default station intercom number is 619; and IMDU communication parameters are 7-bits, even parity, 1-stop bit.*

- 7) Refer to Programming Procedures, Section **100-816-300, Program 77-1**, and set LED 14 to ON to enable IMDU operation.



**FIGURE 5-19**  
**PIOUS PCB SWITCH/JUMPER, OPTION LOCATION**

**NOTE:**  
Refer to *Remote Maintenance Procedures*, Section **100-816-600**, for information regarding the IMDU.

### 12.20 PIOUS and PIOUS Installation Procedure

**12.21** Install the PIOUS or PIOUS in accordance with the following steps:

- 1) Remove the PCB from its protective packaging.
- 2) Ensure the PIOUS or PIOUS has been configured for the appropriate hardware options (refer to Paragraph **12.10** and Section **100-816-207**).
- 3) Insert the PIOUS or PIOUS into slot 06 in the Expansion Unit, and apply firm, even pressure to ensure proper mating of connectors.

- 4) After installing the PIOUS or PIOUS, gently pull the PCB outward. If the connectors are properly mated, a slight resistance will be felt.

### 12.30 PIOUS and PIOUS Wiring

**12.31** Refer to Peripheral Equipment Installation (Section **100-816-207**) and Wiring Diagrams (Section **100-816-208**) for PIOUS/PIOUS wiring/interconnecting details.

### 12.40 PIOUS and PIOUS Programming Overview

**12.41** The following parameters may be specified, through programming, for the PIOUS and PIOUS:

**Program 77-1**

- Assigns relay control and IMDU options.

**Program 60**

- Assigns SMDR options.

**Program 78**

- Enables Night Ringing over External Page.

TABLE 5-G  
PIOUS CONTROLS AND INTERFACE CONNECTORS

CONTROL/INDICATOR/ CONNECTOR (Figure 5-19)	TYPE OF COMPONENT	DESCRIPTION
SMDR/TTY Interface Connector J3	Dual modular connector	Interface connector for SMDR printer/call accounting device and maintenance terminal/modem.
IMDU Connector P1	10-pin connector	Interface connector for Remote Maintenance Modem piggy-back module.
IMDU Connector P2	9-pin connector	Interface connector for Remote Maintenance Modem piggy-back module.
IMDU Connector P3	3-pin connector	Interface connector for Remote Maintenance Modem piggy-back module.
M/B Make/Break Jumper W1	Wire jumper	External Page/Door Lock Control Relay MAKE or BREAK jumper.
M/B Make/Break Jumper W2	Wire jumper	Night/Hold Relay MAKE or BREAK jumper.
Alarm Sensor N.O./N.C. W3	Wire jumper	Alarm sensor normally open or normally closed jumper.
CCITT/BELL Jumper W4*	Wire jumper	IMDU or external modem operating specification jumper plug. (BELL = NO W4)
SMDR Baud Rate Switch SW1	Two-position slide switch	Selects baud rate (300 or 1200 bps) for SMDR printer or call accounting device.
TTY Baud Rate Switch SW2	Two-position locking push-button switch	Selects baud rate (300 or 1200 bps) for Remote Maintenance Modem piggy-back module (IMDU) or external TTY jack.
Modem/TTY Switch SW3	Two-position slide switch	Enables PIOUS for operation with IMDU modem or TTY jack.

\*Most modems in USA require BELL specification: W4 not factory-installed.

### 13 CO LINE/DIGITAL TELEPHONE INTERFACE UNIT (KCDU)

#### 13.00 General

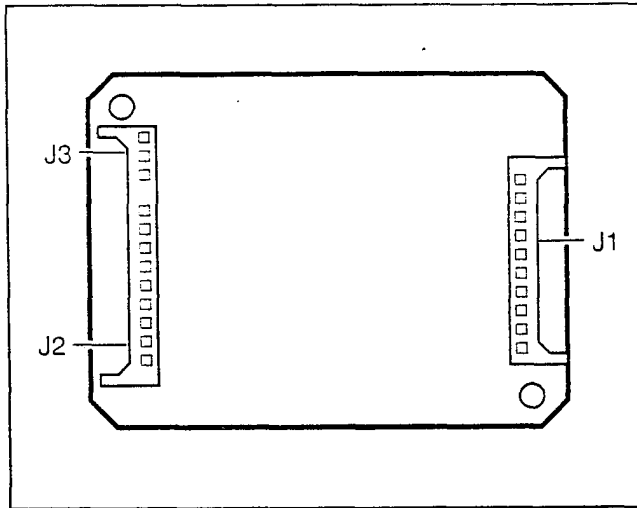
**13.01** The KCDU, which can only be installed in the Expansion Unit of DK16 (it will not function in DK24/56/96), has two loop start CO line circuits and four digital telephone circuits. The KCDU digital telephone circuits can support all but one of the devices supported by either the PDKU or Base Unit integrated digital telephone circuits: digital telephones, PDIU-DIs/PDIU-D12s, PDIU-DSs, ADMs,

and a DDCB. The KCDU does not support a DDSS console. One or two KCDU PCBs may be installed in the Expansion Unit. No other station or CO line PCB can be installed if the KCDU is installed.

**13.02** The KCDU is shown in Figure 5-21, and its controls, connectors, and indicators are described in Table 5-H.

#### 13.10 KCDU Configuration

**13.11** The KCDU may have to be configured to control excessive loudness if the system is close to



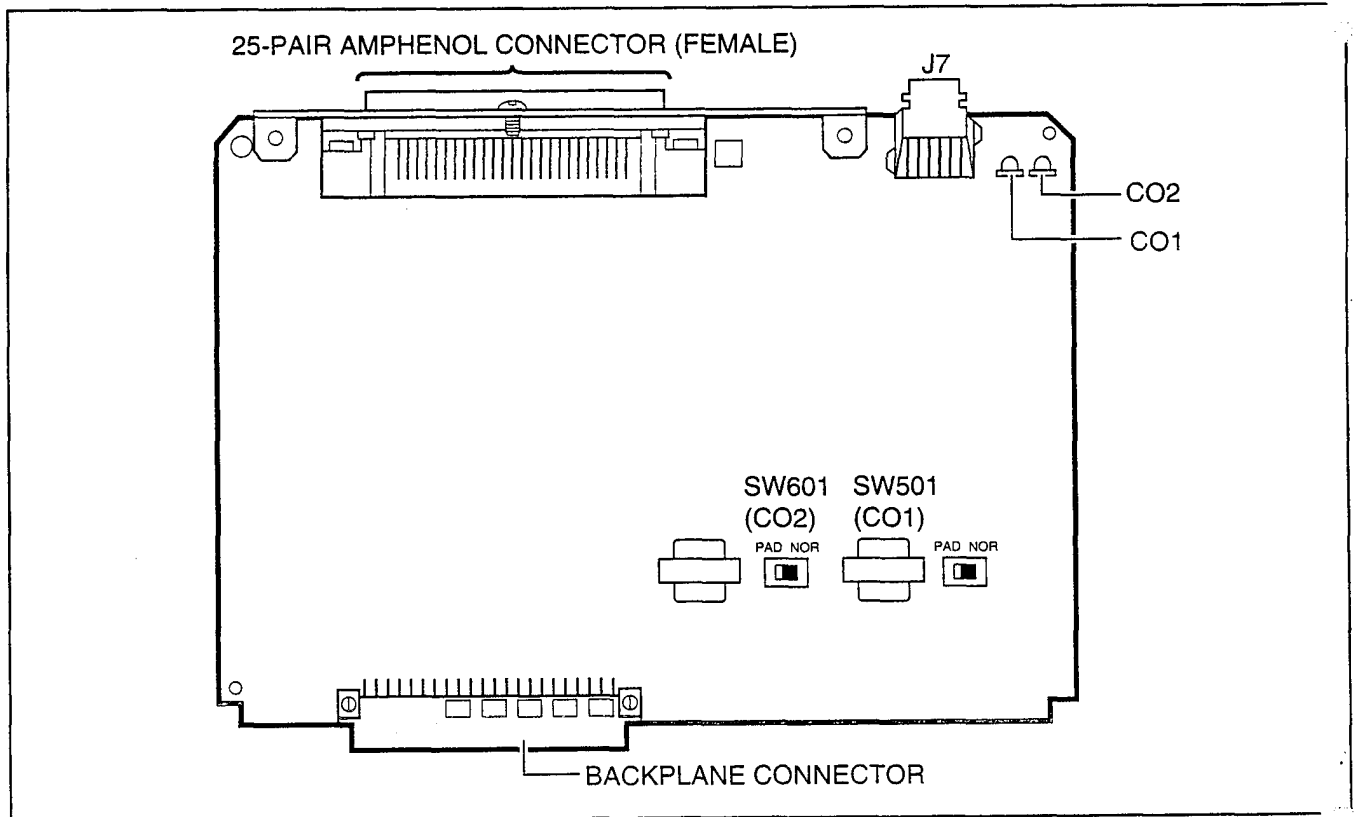
**FIGURE 5-20**  
**REMOTE MAINTENANCE MODEM UNIT (IMDU)**  
**INTERFACE CONNECTORS**

a CO or installed behind a PBX telephone system. It does not have to be configured for anything else. The decibel (db) PAD switches, **SW501** (CO1) and **SW601** (CO2), control the loudness by providing a 3 db signal level drop to, or from, the PBX or CO when set to the PAD position. The switch comes from the factory set at NOR (for normal) meaning no PAD loss.

**13.20 KCDU Installation Procedure**

**13.21** Install the KCDU in accordance with the following steps:

- 1) Remove the PCB from its protective packaging.
- 2) If the system is located within one mile of the CO or PBX telephone system, set db **PAD** switches **SW501** and **SW601** to the PAD position.
- 3) Insert the KCDU into the appropriate slot (04 first, 05 second) in the Expansion Unit, and apply firm, even pressure to ensure proper mating of the connectors.



**FIGURE 5-21**  
**KCDU INDICATORS, OPTIONS, AND CONNECTORS**



TABLE 5-H  
KCDU CONTROLS, INDICATORS, AND CONNECTORS

CONTROL/INDICATOR/ CONNECTOR (Figure 5-21)	TYPE OF COMPONENT	DESCRIPTION
CO line circuit 1 Indicator CD517	Red LED	Lights to indicate CO line circuit 1 is in operation.
CO line circuit 2 Indicator CD617	Red LED	Lights to indicate CC line circuit 2 is in operation.
J7 Connectors	Modular connector	Interface connector for CO line circuits, 1 and 2.
PAD Switch SW501	Two-position slide	Enables 3dB signal level drop for CO line circuit 1 (when set in PAD position).
PAD Switch SW601	Two-position slide	Enables 3dB signal level drop for CO line circuit 2 (when set in PAD position).

- 4) After installing the KCDU, gently pull the PCB outward. If the connectors are properly mated, a slight resistance will be felt.

### 13.30 KCDU Wiring

13.31 Refer to KCDU Wiring Diagram in Section 100-816-208 for wiring/interconnecting details.

### 13.40 KCDU Programming Overview

13.41 See the PCOU programming overview and the PDKU overview in this chapter for KCDU programming information. When running **Program 03** for the KCDU slot(s), specify code 65 if the KCDU does not support OCA or PDIU-DI telephones or code 66 if the KCDU supports OCA or PDIU-DI telephones. Do not specify code 11, 61, 62, or 64.

## 14 DTMF RECEIVER/ABR TONE DETECTOR UNIT (K4RCU)

### 14.00 General

14.01 The K4RCU must be installed to recognize Dual-Tone Multi-Frequency (DTMF) tones generated by a standard telephone (or any other device

connected to a standard telephone circuit) and it is required for Direct Inward System Access (DISA) calls. The K4RCU can only be installed in the Base Unit. The K4RCU circuits are also used to detect busy tone for the Automatic Busy Redial (ABR) feature and must be installed to allow ABR to operate.

### 14.10 K4RCU Configuration

14.11 The K4RCU does not have to be configured for operation.

### 14.20 K4RCU Installation Procedure

14.21 Install the K4RCU in accordance with the following steps (Figure 5-22).

- 1) Remove the PCB from its protective packaging.
- 2) Make sure that the power supply switch is OFF.
- 3) Making sure that the component side of the K4RCU is facing up toward the power supply, plug the K4RCU **P602A** and **P602B** female connectors into the **P2A** and **P2B** (K4RCU) connectors on the motherboard.

### 14.30 K4RCU Wiring

14.31 The K4RCU does not require any wiring.

### 14.40 K4RCU Programming Overview

14.41 The following parameters may be specified:

#### Program 03

- Enter code 92 for Slot 00 if K4RCU is installed.

#### Program 12

- Set K4RCU release time.

#### Program 15

- Sets K4RCU operation after CO line flash.

## 15 BUILT-IN CO LINE AND DIGITAL TELEPHONE CIRCUITS

### 15.00 General

15.01 As mentioned in Paragraph 2, the Base Unit comes standard with four CO lines and eight digital telephone circuits already installed.

### 15.10 Built-in CO Line Circuits

15.11 The four standard loop start CO line circuits are on a printed circuit board (PCB) called the KCOU, which is installed on the motherboard at the factory (Figure 5-23). The KCOU circuits are identical to the PCOU and KCDU CO line circuits. The

KCOU also has four PAD (3 dB) switches—**SW400**, **SW425**, **SW450**, and **SW475**—to reduce excessive loudness caused by a nearby CO or PBX telephone system. For wiring and programming considerations, see the PCOU instructions in Paragraph 8. The Base Unit circuits are fixed and are assigned to Base Unit virtual equipment slots as follows: 8-digital station circuit to slot 01, 4-CO line circuits (KCOU) to slot 02, and 4 standard telephone circuits (KSTU) to slot 3.

### 15.20 Digital Telephone Circuits

15.21 The eight digital telephone circuits that come standard with the system are integrated into the motherboard in the Base Unit. These circuits are identical to the digital circuits found on the PDKU and KCDU. The motherboard does not have to be configured for the digital circuits to operate. For wiring and programming considerations, see the PDKU instructions in Paragraph 7.

### 15.30 Base Unit CO Line/Digital Station Circuit Wiring

15.31 Refer to Section 100-816-208 for details.

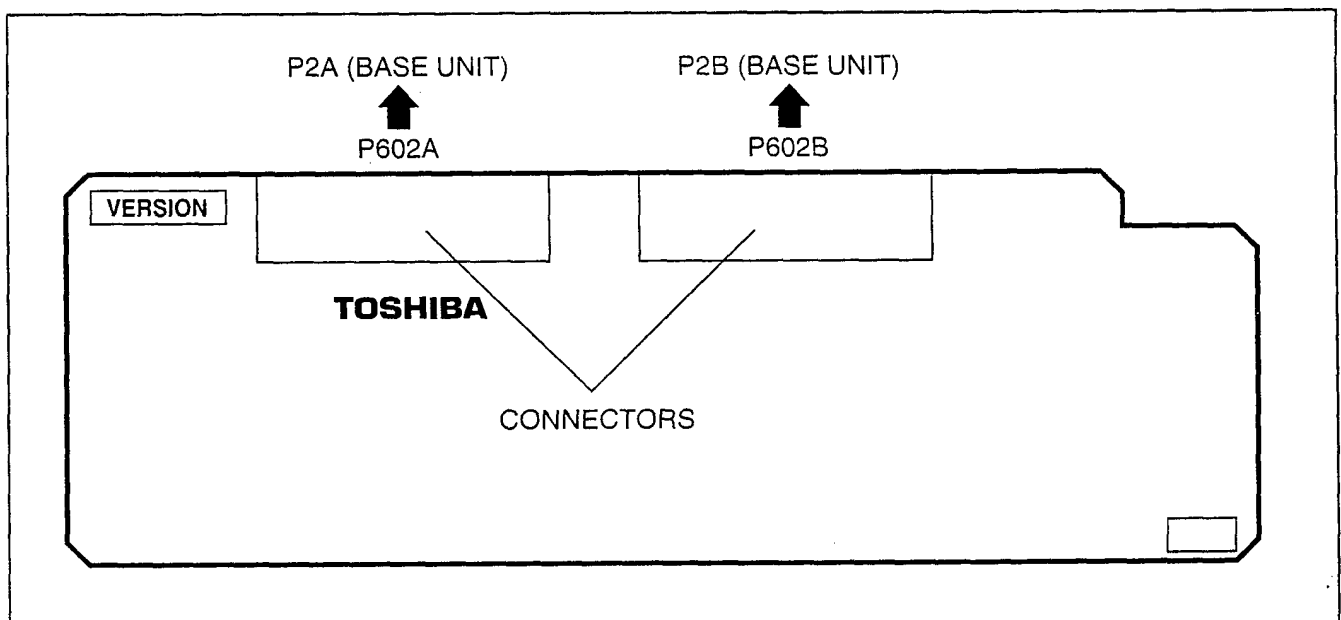


FIGURE 5-22  
K4RCU PCB

## 16 KCOU REMOVAL AND REPLACEMENT

### 16.00 General

16.01 The KCOU comes factory-installed in the Base Key Service Unit (Figure 5-3); if necessary, it can be removed and replaced.

### 16.10 KCOU Removal

- 1) Make sure the Power Supply (KPSU16) DC power switch is turned off.
- 2) Loosen and remove screws 1 and 2 (Figure 5-23).
- 3) Pull back plastic stand-off tab and pull up on KCOU until P7 is unplugged.
- 4) Pull wires on P6 and remove P6 connector from Base Unit.

### 16.20 KCOU Replacement

- 1) Make sure the Power Supply (KPSU16) DC power switch is off.
- 2) Mate and connect KCOU P6 cable connector to P6 on Base Unit motherboard so that the red wire is aligned as shown in Figure 5-23.
- 3) Position KCOU as shown in Figure 5-23.
- 4) Mate and connect KCOU P7 to P7 on the Base Unit motherboard.
- 5) Secure plastic stand-off tab and install screws 1 and 2.
- 6) Set SW400 ~ 475 to appropriate position. In most cases set to the normal position (NOR); if CO lines are connected to a PBX or are in close proximity to the Central Office, set to the PAD position to provide a 3 db loss in signal level.

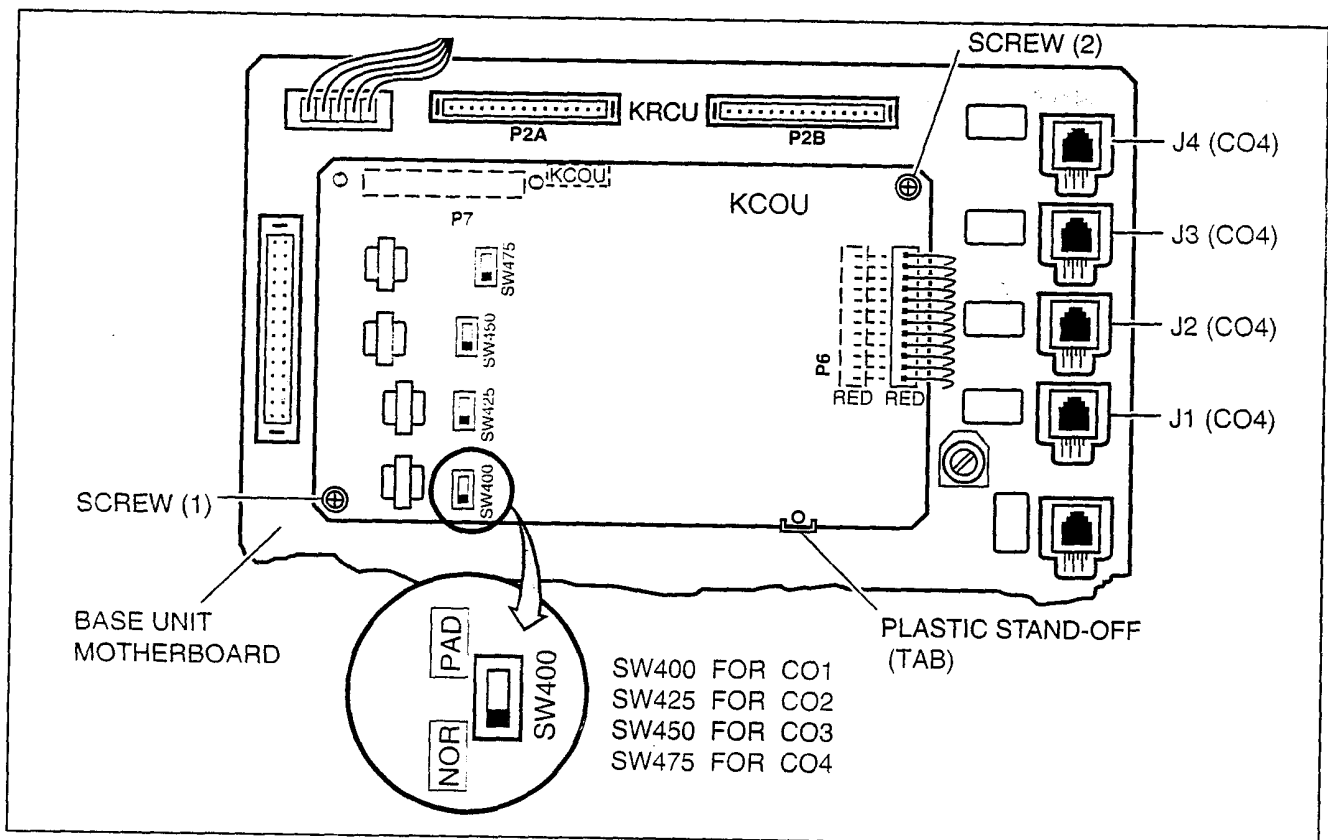


FIGURE 5-23  
 KCOU PCB

### 17 DK16 POWER FAILURE EMERGENCY TRANSFER OPTION

17.00 A dedicated standard telephone can be connected to the Power Failure Transfer Interface (PF1) on the DK16 Base Unit to provide power failure backup. During normal operation, this telephone cannot be used—it does not count as a station; so it does not reduce the system's 20 maximum station capacity. But if there is a power failure, the telephone will automatically be connected to CO line 1. When power is restored, the system will automatically resume with its normal station and CO line assignments, and the dedicated telephone will become inoperative again.

17.10 DK16 Power Failure Emergency Transfer **Installation.** Install the dedicated emergency standard telephone as follows (see Figure 5-24):

- 1) Connect a standard telephone to the PF1 connector in the Base Unit.

17.11 DK16 Power Failure Emergency Transfer **Test.**

- 1) Turn the system power switch off.
- 2) Lift the emergency standard telephone handset, and verify that there is CO dial tone.

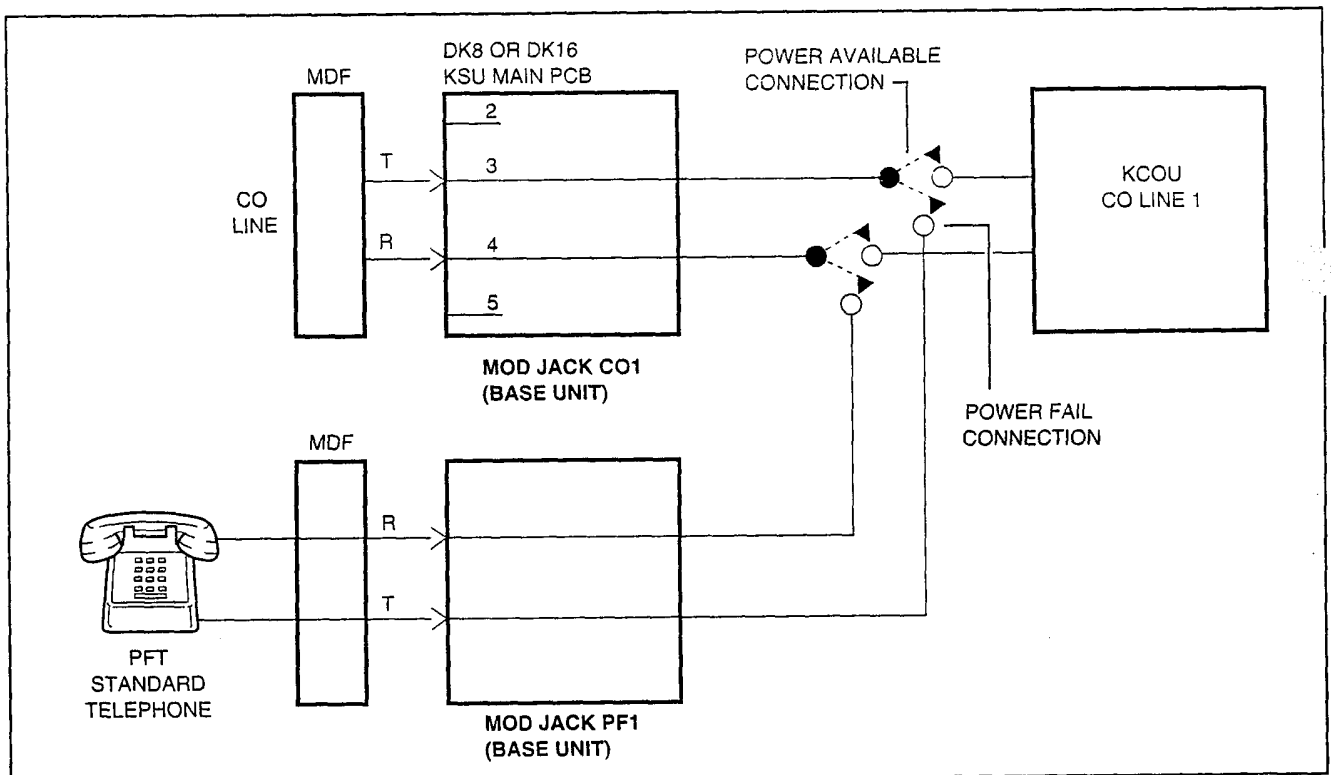


FIGURE 5-24  
DK16 BASE UNIT POWER FAILURE TRANSFER (PFT) CIRCUIT DIAGRAM

# **Strata**<sup>®</sup> DK8 & DK16

## **INSTALLATION**

### **CHAPTER SIX**

### **STATION APPARATUS INSTALLATION**

TABLE OF CONTENTS

PARAGRAPH	SUBJECT	PAGE
1	OVERVIEW .....	6-1
1.00	Purpose .....	6-1
1.10	Types of Telephones .....	6-1
2	TELEPHONE INSTALLATION .....	6-1
2.00	General .....	6-1
2.10	Connecting Digital Telephones to the System .....	6-1
2.20	Connecting Electronic Telephones to the System (DK16 only) .....	6-2
2.30	Connecting Standard Telephones to the System .....	6-2
2.40	Telephone Wall Mounting .....	6-2
3	DIGITAL TELEPHONE UPGRADES .....	6-4
3.10	Simultaneous Voice and Data Upgrade (PDIU-DI2 and PDIU-DI) .....	6-4
3.20	Off-hook Call Announce Upgrade (DVSU) .....	6-6
3.30	Loud Ringing Bell/Headset Upgrade (HHEU) .....	6-6
3.40	Carbon Headset/Handset Straps .....	6-9
3.50	Beep Strap .....	6-9
3.60	Microphone/Speaker Sensitivity Adjustment (Speakerphones Only) .....	6-10
3.70	Busy Override and Camp-on Ring Tone Over Handset/Headset Option .....	6-10
3.80	External Power Straps .....	6-10
3.90	DKT2000 Add-On-Module Installation .....	6-11
4	ELECTRONIC TELEPHONE UPGRADE OPTIONS (DK16 Only) .....	6-11
4.10	Off-hook Call Announce Upgrade (HVSU2 or HVSU/HVSI) .....	6-11
4.20	Loud Ringing Bell/Headset Upgrade (HHEU) .....	6-12
4.30	Carbon Headset/Handset Straps .....	6-13
4.40	Beep Strap .....	6-14
4.50	Microphone/Speaker Threshold (Speakerphones Only) .....	6-14
4.60	Handset Receiver Volume-Up Strap (Version 2 6500-Series Telephones Only) ..	6-14
5	DIRECT STATION SELECTION CONSOLE/SYSTEM CONNECTION (DK16 Only) .....	6-14
5.10	DDSS Console Connections .....	6-14
5.20	HDSS Console Connections .....	6-15
6	DOOR PHONE/LOCK CONTROL UNIT AND DOOR PHONE INSTALLATION .....	6-15
6.10	DDCB and MDFB Cabling .....	6-16
6.20	DDCB Wall Mounting .....	6-16
6.30	Door Phone (MDFB) Wall Mounting .....	6-16
6.40	Door Phone/Lock Programming Considerations .....	6-17
7	ADD-ON MODULE INSTALLATION .....	6-17

FIGURE LIST

FIGURE	TITLE	PAGE
6-1	REMOVING THE TELEPHONE BASE .....	6-3
6-2	HANDSET HANGER .....	6-3
6-3	WALL MOUNTING BASE ROTATION .....	6-3
6-4	PDIU-DI2 INSTALLATION INTO 2000-SERIES DIGITAL TELEPHONE .....	6-5
6-5	PDIU-DI INSTALLATION INTO 1000-SERIES DIGITAL TELEPHONE .....	6-5
6-6	DVSU INSTALLATION FOR DIGITAL TELEPHONES .....	6-6
6-7	DKT2010-H STRAP AND CONNECTOR LOCATIONS .....	6-7
6-8	DKT2010-SD, DKT2020-S, AND DKT2020-SD STRAP AND CONNECTOR LOCATIONS .....	6-7
6-9	1000-SERIES DIGITAL TELEPHONE STRAP AND CONNECTION LOCATIONS .....	6-7
6-10	HHEU INSTALLATION FOR DIGITAL TELEPHONE .....	6-8
6-11	HESC-65A CABLING .....	6-8
6-12	HVSU2 INSTALLATION FOR ELECTRONIC TELEPHONES .....	6-11
6-13	ELECTRONIC TELEPHONE PCB CONNECTIONS .....	6-12
6-14	HVSI/HVSU INSTALLATION FOR ELECTRONIC TELEPHONES .....	6-12
6-15	HHEU INSTALLATION FOR ELECTRONIC TELEPHONES .....	6-13
6-16	DOOR PHONE (DDCB) INSTALLATION .....	6-16
6-17	DOOR PHONE (MDFB) INSTALLATION .....	6-17
6-18	ADD-ON-MODULE INSTALLATION .....	6-17
6-19	DK16 ADD-ON-MODULE DSS BUTTON ASSIGNMENTS .....	6-18
6-20	DK8 ADD-ON-MODULE DSS BUTTON ASSIGNMENTS .....	6-18

## 1 OVERVIEW

### 1.00 Purpose

**1.01** This chapter provides instructions on how to connect telephones to the STRATA DK8 and DK16 systems and how to configure and upgrade them for optional features. Procedures for installing direct station selection consoles and door phones also appear in this chapter.

### 1.10 Types of Telephones

**1.11** The STRATA DK8 and DK16 systems can support the following telephones.

- **Digital Telephones:** Installation instructions for digital telephones in this chapter and elsewhere in this manual apply only to the Toshiba 2000- and 1000-series Digital Telephones. The 2000-series Digital Telephones consist of four models: the DKT2010-H, the DKT2010-SD, the DKT2020-S, and the DKT2020-SD. There are two 1000-series Digital Telephone models, the DKT1020-H and the DKT1020-SD.
- **Electronic Telephones:** (DK16 only) The electronic telephone instructions here apply to the Toshiba 6500-series Electronic Telephones, although there are other electronic telephones (the 2000-, 3000-, 6000-, and 6500-series) that are compatible with the STRATA DK16. The 6500-series electronic telephones consist of four models: the EKT6510-H, the EKT6510-S, the EKT6520-H, and the EKT6520-SD.
- **Standard Telephones:** 500- and 2500-type standard telephones apply whenever standard telephones are mentioned in this manual.

## 2 TELEPHONE INSTALLATION

### 2.00 General

**2.01** This section describes the wiring required to connect telephones to the system. Before installing any telephone wiring, read the following warning and caution notes:

#### WARNING!

1. *Never install the telephone wiring during a lightning storm.*
2. *Never install the telephone jacks in wet locations, unless the jack is specifically designed for wet locations.*
3. *Never touch uninsulated telephone wires or terminals unless the telephone line has been disconnected at the network interface.*
4. *Use caution when installing or modifying telephone lines.*
5. *If telephone, DSS console, Door phone control box, or Door phone wiring exits the building, external secondary protection is required. See Section 100-816-208.*

#### CAUTION!

*When installing the station cable, do not run parallel to and within three feet of an AC power line. AC power lines should be crossed at right (90°) angles only. In particular, avoid running station wire pairs near devices that generate electrical noise, such as neon or fluorescent light fixtures.*

### 2.10 Connecting Digital Telephones to the System

**2.11** The following provides information on how to connect digital telephones to the DK8 or DK16 system.

#### NOTE:

*Before proceeding, see warning and caution notes in Paragraph 2.01.*

**2.12** Digital telephones connect to the digital telephone ports via the main distribution frame (MDF) with standard twisted-pair jacketed telephone cable. Single-pair wiring is sufficient in most cases for digital telephones to operate effectively at up to 1000 feet from the key service unit, if using 24 AWG cable. But digital telephones that are equipped with Integrated Data Interface Units or ADMs should have two-pair (or external power) to function effectively at this distance. This also applies to digital telephones that are supported by systems that must operate with battery reserve power—see Wiring Diagrams, Section 100-816-208, for loop limits (see Table 8-D).



INSTALLATION-STATION APPARATUS  
SECTION 100-816-206  
MARCH 1993

To accommodate the digital telephone line cord, the cable should be terminated in a modular station connector block (RJ-11) at the station location. The standard single-pair, modular digital telephone cord that is sent with the telephone is 7 feet (the maximum allowed is 25 feet).

**NOTES:**

1. *Digital telephone cable runs must not have the following:*
  - Cable splits (single or double)
  - Cable bridges (of any length)
  - High resistance or faulty cable splices
2. See Section **100-816-208** for secondary protector information.

**2.20 Connecting Electronic Telephones to the System (DK16 only)**

**2.21** The following provides information on how to connect electronic telephones to the DK16 system.

**NOTE:**

*Before proceeding, see warning and caution notes in Paragraph 2.01.*

**2.22** Electronic telephones are connected to electronic telephone circuits in the DK16 Expansion Unit on the Electronic Telephone Interface Unit (PEKU) and the Standard/Electronic Telephone Interface Unit (PESU) via the main distribution frame (MDF) with standard twisted-pair jacketed telephone cable. Two-pair wiring, as a minimum, is required for telephone connection. However, three-pair wiring is recommended to permit future upgrades, such as Off-hook Call Announce.

To accommodate the electronic telephone line cord, the cable should be terminated in a modular station connector block (RJ-11) at the station location. The standard two-pair modular electronic telephone cord length is seven feet (the maximum allowed length is 25 feet). See Wiring diagrams, Section **100-816-208** for more details.

**NOTE:**

*See Section 100-816-208 for secondary protector information.*

The overall length of the station cable run from the DK16 key service unit (KSU) to the telephone must not exceed 1,000 feet (305 meters), if using 24 AWG cable.

**2.30 Connecting Standard Telephones to the System**

**2.31** The following provides information on how to connect standard telephones to the DK8 or DK16 system.

**NOTE:**

*Before proceeding, see warning and caution notes in Paragraph 2.01.*

**2.32** Standard telephones connect to standard telephone circuits in the DK8 Standard Telephone Interface Unit (QSTU), telephone circuits on the DK16 Base Unit Standard Telephone Interface Unit (KSTU), the DK16 Standard Telephone Interface Unit (PSTU), and the DK16 Standard/Electronic Telephone Interface Unit (PESU) via the main distribution frame (MDF) with standard twisted-pair jacketed telephone cable. Single-pair wiring is required. (Refer to Wiring Diagrams, Section **100-816-208**, for more details.)

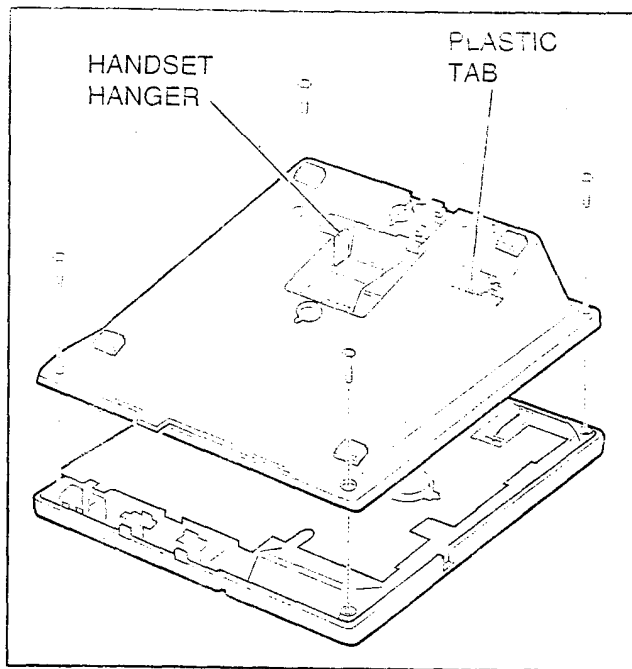
**NOTE:**

*See Section 100-816-208 for secondary protector information.*

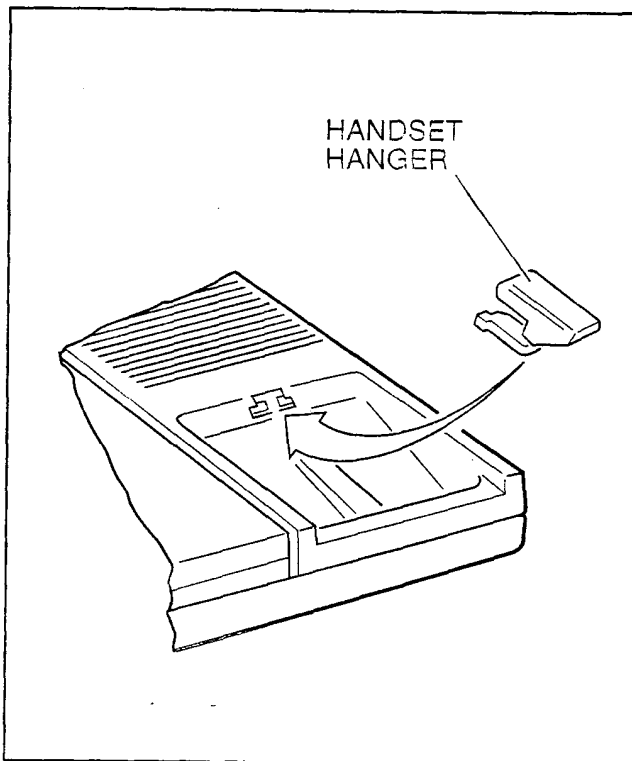
The standard telephone cable's overall loop resistance, connected on- or off-premises, is 300 ohms maximum, including the telephone resistance. This also applies to all devices connected to standard telephone circuits. A standard telephone, connected off-premises via the telephone network, should interface with OL13A lines (or equivalent) and connect to an RJ21X FIC jack (or equivalent).

**2.40 Telephone Wall Mounting**

**2.41** This section provides instructions on how to mount digital telephones and electronic telephones (DK16 only) to a wall or other vertical surface. Instructions on mounting standard telephones are not provided here; refer to the manufacturer's documentation for those instructions.



**FIGURE 6-1**  
**REMOVING THE TELEPHONE BASE**

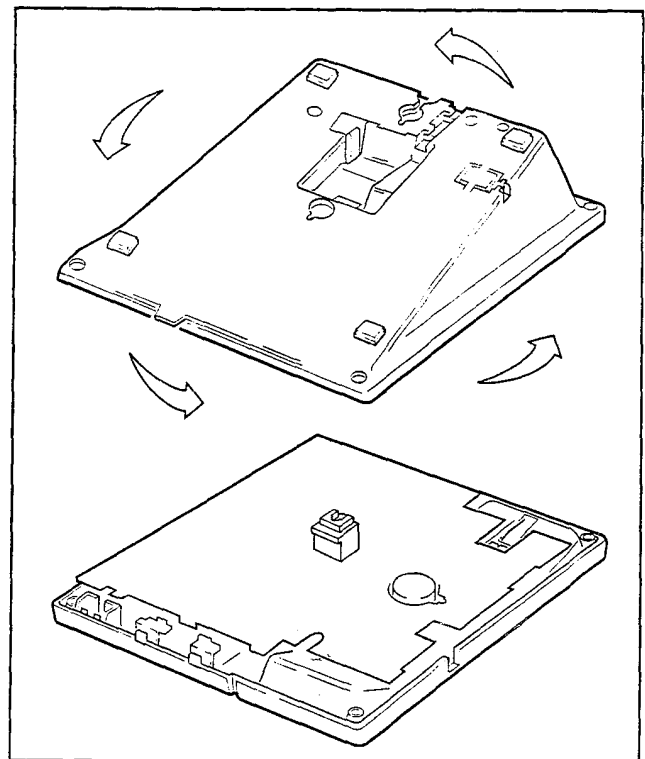


**FIGURE 6-2**  
**HANDSET HANGER**

2.42 Mount digital and electronic telephones in accordance with the following steps:

**NOTES:**

1. Digital telephones equipped with Integrated Data Interface Units (PDIU-DIs or PDIU-DI2s) cannot be wall mounted.
  2. Electronic and older digital telephones equipped with an HHEU1 can be wall mounted. 2000-series Digital Telephones with headsets can only be wall mounted with an HHEU2.
- 1) Loosen the captive screws, and remove the telephone base (Figure 6-1).
  - 2) Using a suitable cutter, remove the handset hanger from the base (Figure 6-1). Insert the handset hanger in the slot provided on the front of the telephone (Figure 6-2). The hanger fits in the notch on the handset cradle.
  - 3) Rotate the telephone base 180 degrees and secure it to the telephone with its four captive screws (Figure 6-3).



**FIGURE 6-3**  
**WALL MOUNTING BASE ROTATION**

- 4) Connect the telephone to the wall modular connector with a cord approximately four inches long (available at most telephone supply companies). Route the cord into the hollow portion of the base.
- 5) Mount the telephone on the wall mounting modular connector plate.

### 3 DIGITAL TELEPHONE UPGRADES

**3.00** This section describes how to upgrade and configure 2000- and 1000-series Digital Telephones for features and options.

#### 3.10 Simultaneous Voice and Data Upgrade (PDIU-DI2 and PDIU-DI)

**3.11** Both the 2000- and 1000-series Digital Telephones can be upgraded with an integrated data interface unit to transmit and receive simultaneous voice and data calls. There are two versions of the integrated unit: the PDIU-DI and the PDIU-DI2. The 2000-series telephones can only be equipped with a PDIU-DI2, and the 1000-series telephones can only be equipped with a PDIU-DI. Asynchronous devices, such as personal computers (PC) and terminals, can be connected to the standard RS-232 connector of the PDIU-DI(2). Station users are able to transmit and receive RS-232 data over the single wire pair of the PDIU-DI(2)-equipped telephone.

**3.12** Data calls can be manually dialed with a **Data Call** button and disconnected with a **Data Release** button on the telephone; or, data and voice calls can be dialed from the keyboard of the terminal or PC using standard "AT" commands. Digital telephones may also be assigned a **Modem** button to reserve a modem or monitor modem availability and status. Assign feature buttons to telephones with **Program 39**.

#### NOTES:

1. 1000- and 2000-series Digital Telephones equipped with a PDIU-DI(2) cannot be wall-mounted or equipped with an Add-On-Module (ADM), or DVSU for OCA. A 2000-series digital telephone equipped

*with a PDIU-DI2 can support an HHEU at the same time, but cannot support a DVSU. A 1000-series Digital Telephone equipped with a PDIU-DI cannot support an HHEU, ADM, or a DVSU for OCA.*

2. PDKU1 circuits 1 ~ 7 only can support PDIU-DI(2)s, but all PDKU2 and base unit digital circuits, can support PDIU-DI(2)s.

**3.13 PDIU-DI(2) Installation.** Install the integrated data interface unit (PDIU-DI for 1000-series and PDIU-DI2 for 2000-series) in accordance with the following steps:

- 1) Loosen the four captive screws securing the digital telephone base and remove it (Figure 6-1).
- 2) Refer to Figure 6-4 for 2000-series telephones or Figure 6-5 for 1000-series telephones, and insert the two integrated unit wire plugs into the connectors on the printed circuit board (PCB) in the telephone (observing the re-wire for correct positioning).
- 3) Attach the integrated unit to the bottom of the telephone and secure with the four captive screws.
- 4) Remove the telephone number directory tray from the original telephone base and install it on the integrated unit telephone base. Bend the tray by squeezing its sides so it bows slightly to remove and re-install (Figure 6-4 or 6-5).
- 5) Check Table 8-D in Section **100-816-208**; install 2-pair house cable (or external power) and 2-pair modular cord (supplied with PDIU-DI) if required to achieve maximum distance.

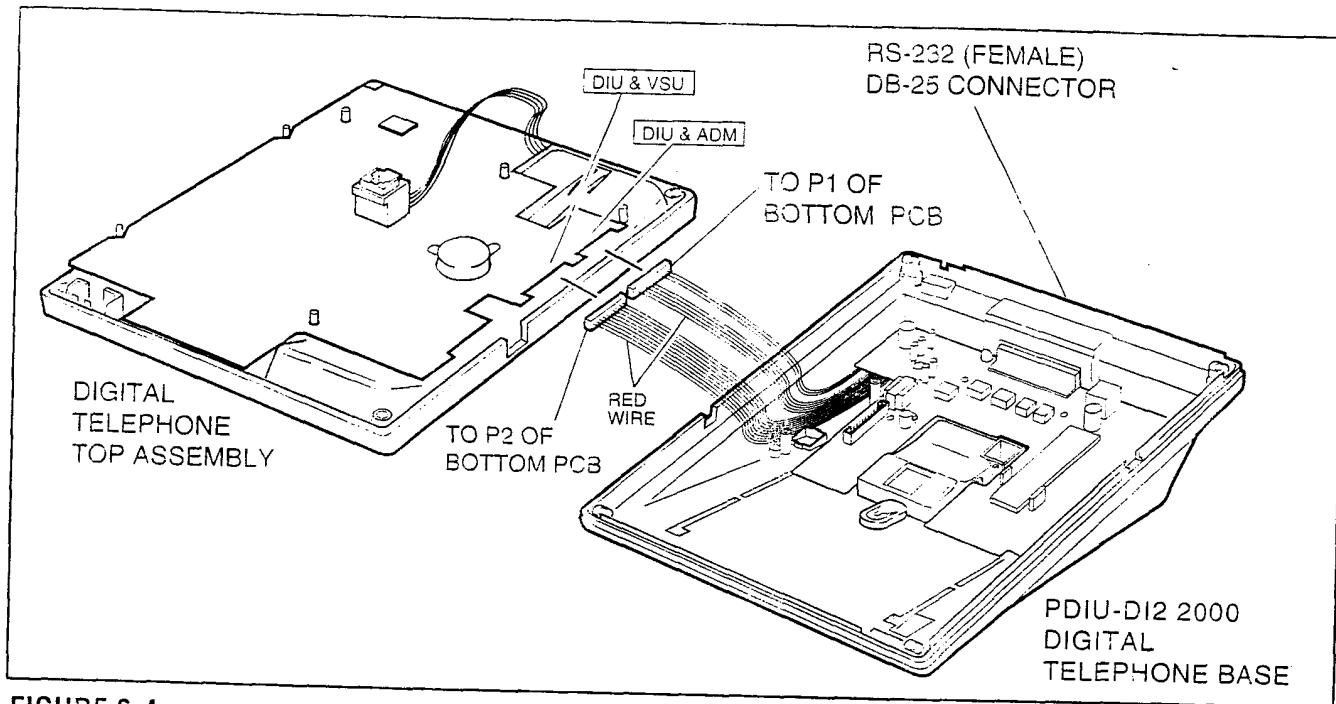
#### 3.14 Integrated Data Interface Unit Programming Overview

##### Program 39

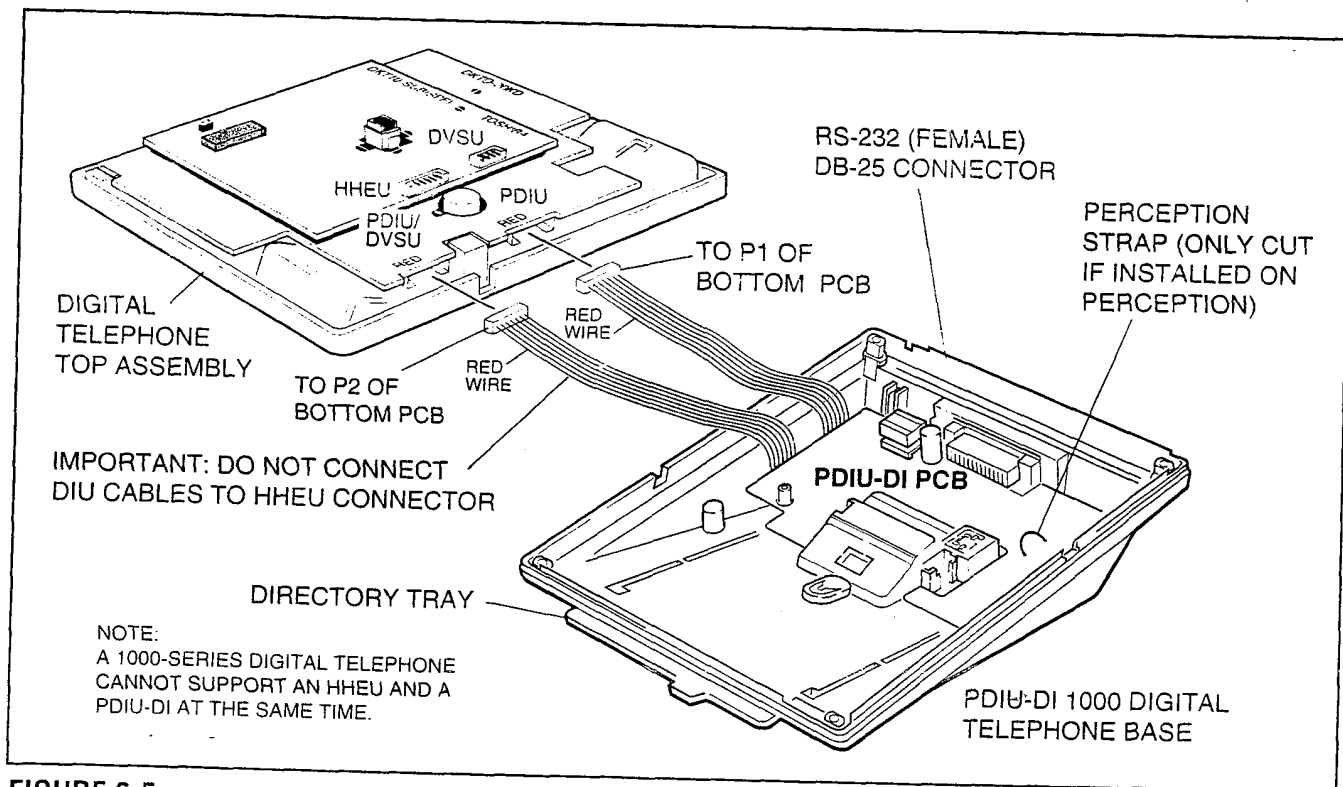
- Assigns the **Data Call**, **Data Release**, and **Modem** buttons.

##### Programs 20 and 22

- Used for data interface unit assignments.



**FIGURE 6-4**  
**PDIU-DI2 INSTALLATION INTO 2000-SERIES DIGITAL TELEPHONE**



**FIGURE 6-5**  
**PDIU-DI INSTALLATION INTO 1000-SERIES DIGITAL TELEPHONE**

### 3.20 Off-hook Call Announce Upgrade (DVSU)

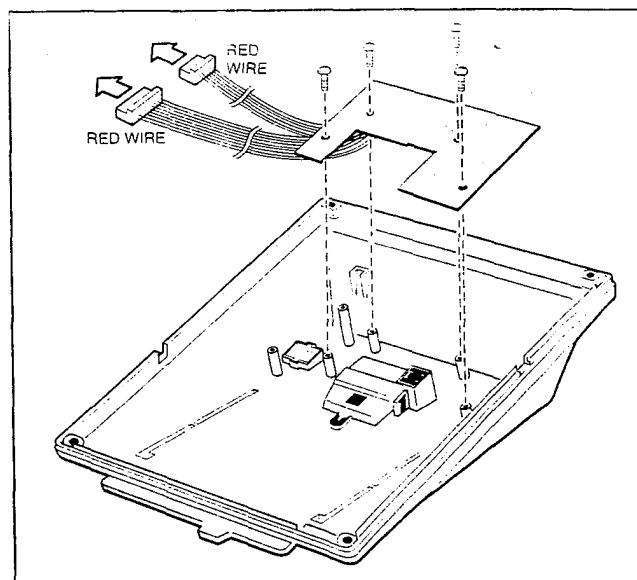
**3.21** To receive Off-hook Call Announce (OCA) calls, a digital telephone must be upgraded with a DVSU; the telephone making the call does not require a DVSU. An additional wire pair is not required for digital telephones that receive OCA calls. The DVSU is compatible with both 2000-series and 1000-series Digital Telephones.

**NOTE:**

*Digital telephones cannot be equipped with a DVSU and integrated data interface unit (PDIU-DI or PDIU-DI2) at the same time.*

**3.22 DVSU Upgrade Installation.** Install the DVSU upgrade in accordance with the following steps.

- 1) Loosen the four captive screws securing the telephone base (Figure 6-1) and remove the base.
- 2) Loosen the four captive screws securing the metal plate to the standoffs inside the base where the DVSU will be installed (Figure 6-6). Remove the plate, which can be discarded.
- 3) Position the DVSU PCB on the standoffs (Figure 6-6), and secure with the four provided screws.
- 4A) If installing the DVSU into a 2000-series digital telephone, refer to Figure 6-7 (DKT2010-H) or Figure 6-8 (DKT2010-SD, DKT2020-S, DKT2020-SD), and then connect the DVSU wire plugs to the **DVSU** connectors on the printed circuit board (PCB) inside the telephone.
- 4B) If installing the DVSU into a 1000-series digital telephone, refer to Figure 6-9, and connect the DVSU wire plugs to the **DVSU** connectors on the PCBs inside the telephone.
- 5) Reinstall the telephone base and secure it with its four captive screws.



**FIGURE 6-6**  
**DVSU INSTALLATION FOR DIGITAL**  
**TELEPHONES**

### 3.30 Loud Ringing Bell/Headset Upgrade (HHEU)

**3.31** The loud ringing bell/headset upgrade (HHEU) enables an external speaker (HESB) for the Loud Ringing Bell feature and/or a headset to be connected to both series of digital telephones.

**NOTES:**

1. There are two types of HHEU: the HHEU1 (which has four versions, V.1 ~ V.4) and the HHEU2.
2. Both 2000- and 1000-series Digital Telephones require either an HHEU2 or a V.3 or V.4 HHEU1 for HESB operation; earlier HHEU1 versions are only sufficient for headset operation only.
3. Only digital telephones equipped with an HHEU2 can be wall mounted. The HHEU2 is identical to the V.4 HHEU1, except that the HHEU2 has longer wires to accommodate wall mounting.
4. A Toshiba HESC-65A cable is required to connect the HHEU in a digital telephone to the HESB.
5. 1000-series digital telephones cannot be equipped with the HHEU (any type or

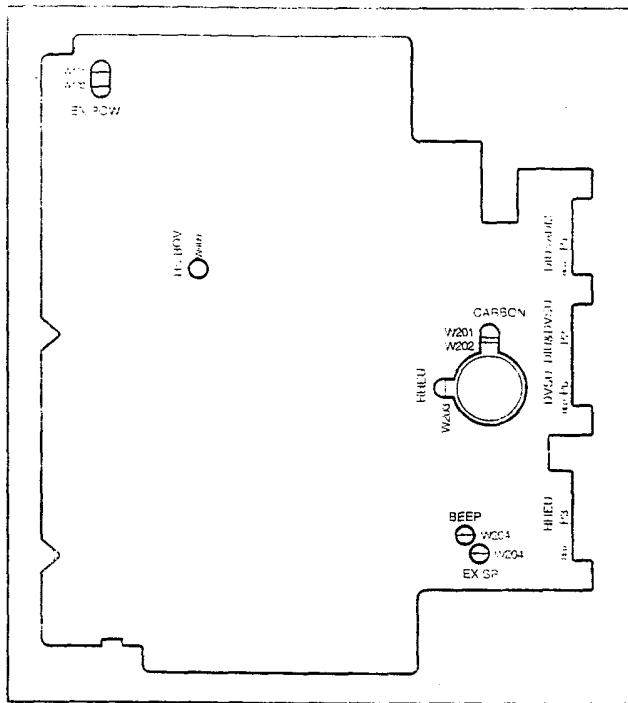


FIGURE 6-7  
DKT2010-H STRAP AND CONNECTOR  
LOCATIONS

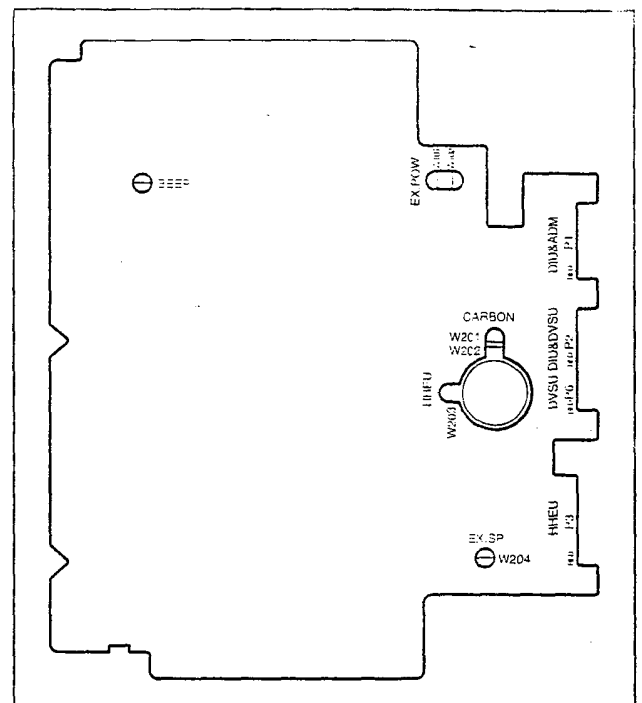


FIGURE 6-8  
DKT2010-SD, DKT2020-S, AND DKT2020-SD  
STRAP AND CONNECTOR LOCATIONS

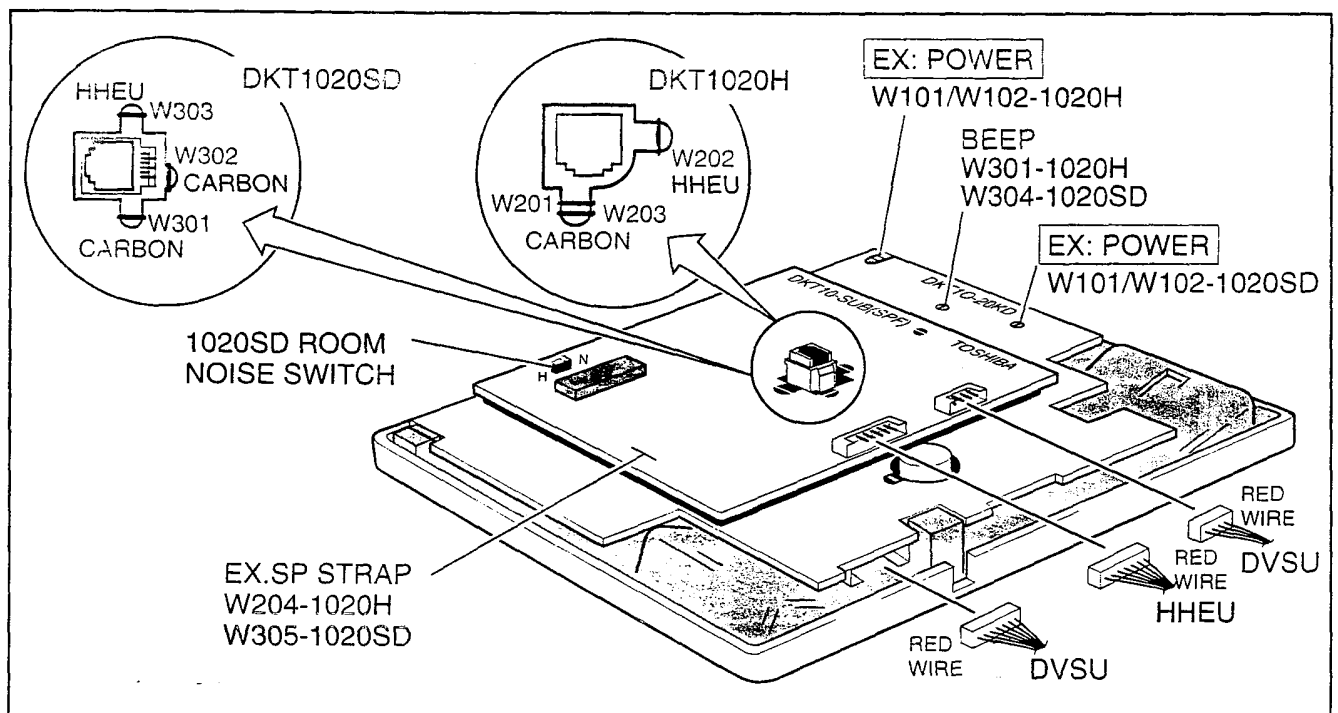
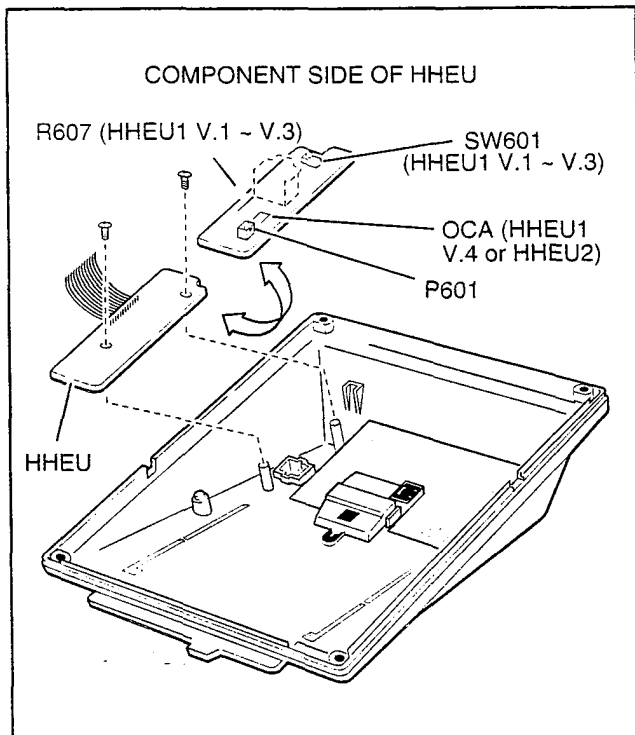


FIGURE 6-9  
1000-SERIES DIGITAL TELEPHONE STRAP AND CONNECTION LOCATIONS

*version) and the integrated data interface unit (PDIU-DI) at the same time, but 2000-series digital telephones can support an HHEU and a PDIU-DI2 at the same time.*

**3.32 HHEU Upgrade Installation (HHEU)** Install the Loud Ringing Bell/headset upgrade (HHEU) in accordance with the following steps.

- 1) Loosen the four captive screws securing the telephone base (Figure 6-1), and remove the base.
- 2) Using a screwdriver or other suitable tool, remove the plastic tab located on the back of the base (Figure 6-1); the HHEU modular connector for the headset will be accessed through this opening.
- 3) If installing a V.3 HHEU1, set the SW601 switch on the HHEU to **HEADSET** for the headset or loud bell application (Figure 6-10). V.4 HHEU1 and HHEU2 do not have this switch, because both of these upgrades are automatically set for the headset/loud bell application.



**FIGURE 6-10**  
**HHEU INSTALLATION FOR DIGITAL TELEPHONE**

- 4) Connect the HESC-65A cable to P601 of the HHEU (both HHEU1A versions and the HHEU2 have P601) if the Loud Ringing Bell option is required (Figure 6-11). Refer to Section 100-816-207 for HESB installation procedures.

- 5A) For the V.3 HHEU1: If only the headset is connected to the HHEU, cut both sides of the R607 resistor (Figure 6-10), then remove the resistor to eliminate electrical contact.

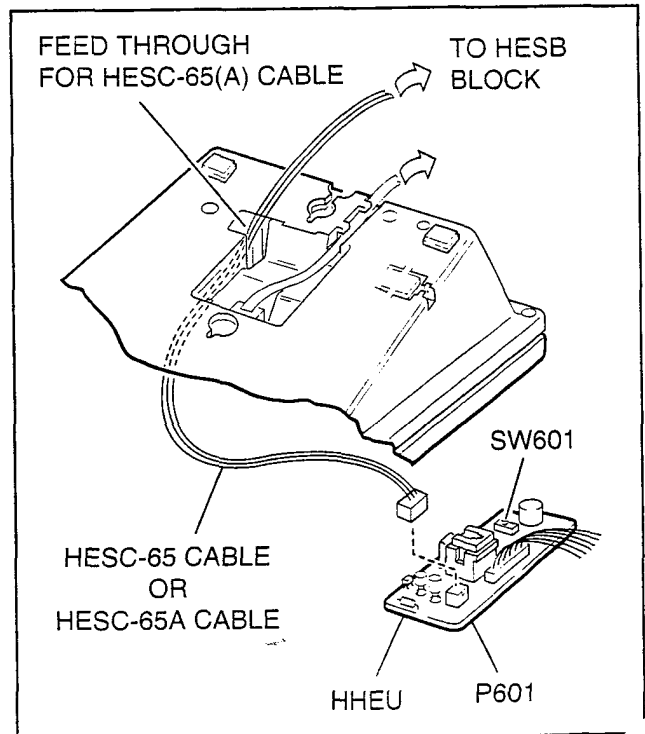
**NOTE:**

*Do not cut the R607 resistor if connecting an HESB to the HHEU for the Loud Ringing Bell—even if a headset is also installed on the HHEU.*

- 5B) For the V.4 HHEU1 and the HHEU2: If only the headset is connected to the HHEU, cut the OCA strap (Figure 6-10).

**NOTE:**

*Do not cut the OCA strap if connecting an HESB to the HHEU for the Loud Ringing*



**FIGURE 6-11**  
**HESC-65A CABLING**

*Bell—even if a headset is also installed on the HHEU.*

- 6) Position the HHEU PCB on the standoffs inside the base (Figure 6-10), and secure with the two provided screws.
- 7A) For 2000-series digital telephones, refer to Figure 6-7 (DKT2010-H) or Figure 6-8 (DKT2010-SD, DKT2020-S, DKT2020-SD), and connect the wire plug of the HHEU PCB to the **HHEU** connector on the printed circuit board (PCB) on the telephone.
- 7B) For 1000-series digital telephones, refer to Figure 6-9, and connect the wire plug of the HHEU to the **HHEU** connector on the PCB of the telephone.
- 8A) For 2000-series digital telephones, refer to Figure 6-7 (DKT2010-H) or Figure 6-8 (DKT2010-SD, DKT2020-S, DKT2020-SD), and locate the **EX.SP** strap on the PCB in the telephone. Cut the strap if an HESB will be connected to the HHEU.
- 8B) For 1000-series digital telephones, refer to Figure 6-9, and locate the **EX.SP** strap on the upper PCB in the telephone, and cut it if an HHEU will be connected to an HESB for the Loud Ringing Bell option.
- 9A) For 2000-series digital telephones, refer to Figure 6-7 (DKT2010-H) or Figure 6-8 (DKT2010-SD, DKT2020-S, DKT2020-SD), and locate the **HHEU** strap on the PCB in the telephone. Cut the strap if a headset will be connected to the HHEU.
- 9B) For 1000-series digital telephones, refer to Figure 6-9, and locate the **HHEU** strap on the upper PCB in the telephone. Cut the strap if an HHEU will be connected to a headset.

**NOTE:**

*If the HHEU PCB is removed from the telephone, the HHEU strap must be replaced for proper telephone operation.*

- 10) Reinstall the telephone base, and secure it with its four captive screws.

- 11) To adjust the volume of the HESB Loud Ringing Bell: Call the telephone connected to the HESB, and adjust the volume control on the back of the HESB and the ring volume control on the telephone.

### 3.40 Carbon Headset/Handset Straps

**3.41** If a carbon-type handset or headset is connected to the handset jack on the side of the telephone, two jumper straps inside the telephone must be cut. Cut the straps in accordance with the following steps:

**NOTE:**

*It is not necessary to cut these straps if the headset is connected to the HHEU.*

- 1) Loosen the four captive screws securing the telephone base (Figure 6-1), and remove the base.
- 2A) For 2000-series digital telephones refer to Figure 6-7 or 6-8, and cut the **CARBON** straps, **W201** and **W202**.
- 2B) For 1000-series digital telephones, refer to Figure 6-9, and cut the **CARBON** straps, (**W301** and **W302** on the DKT1020-SD; **W201** and **W203** on the DKT1020-H).
- 3) Reinstall the telephone base, and secure it with its four captive screws.

### 3.50 Beep Strap

**3.51** A "beep" sounds whenever a dialpad button or feature button is pressed on a digital telephone. To eliminate this beep follow the procedure below:

- 1) Loosen the four captive screws securing the telephone base (Figure 6-1), and remove the base.
- 2A) For 2000-series digital telephones, refer to Figures 6-7 or 6-8, and cut the **BEEP** strap.
- 2B) For 1000-series digital telephones, refer to Figure 6-9, and cut the **BEEP** strap.
- 3) Reinstall the telephone base, and secure it with its four captive screws.



### 3.60 Microphone/Speaker Sensitivity Adjustment (Speakerphones Only)

**3.61** High ambient noise levels may cause the speaker on some digital telephone speakerphone models to cut off frequently. To prevent this for the 1000-series digital telephone models, perform the following procedure to make the telephones less sensitive to the noise: (The 2000-series Telephones are adjusted per the instructions in the Note after the procedure.)

- 1) Loosen the four captive screws securing the 1000-series Digital Telephone speakerphone base (Figure 6-1), and remove the base.
- 2) For the 1000-series speakerphone model (DKT1020-SD), refer to Figure 6-9, and locate the **ROOM NOISE** switch. Push the switch carefully to the **H** (high) position (for low sensitivity) when there is high background noise in the area surrounding the telephone.
- 3) Reinstall the telephone base, and secure it with its four captive screws.

#### NOTES:

1. To make the 2000-series Digital Telephone speakerphone models less sensitive to loud surrounding noise, hold down **Mic** button, then press the up **Vol** button. The less-sensitive level will be set after the third flash of the Mic LED. To reset the sensitivity back to the normal level, hold down the **Mic** button, then press the down **Vol** button. The normal level will be set after the third flash of the Mic LED.
2. On 2000-series Digital Telephone speakerphone models that are set for low sensitivity, the Mic LED will flash at the in-use rate when using the speakerphone. When set to normal sensitivity, the Mic LED will be on steady when using the speakerphone.

### 3.70 Busy Override and Camp-on Ring Tone Over Handset/Headset Option

**3.71** The Busy Override and Camp-on Ring tones can be sent over the telephone handset or head-

set, in addition to the speaker, with 2000-series digital telephones. The tones only sound over the speaker with 1000-series Digital Telephones. Perform the following procedure to have these tones sent over the handset of the DKT2010-H model: (For the DKT2010-SD, the DKT2020-S, and the DKT2020-SD models, see the Note following the procedure.)

- 1) Loosen the four captive screws securing the telephone base (Figure 6-1), and remove the base.
- 2) Refer to Figure 6-7, and install a strap in the **HS-BOV W409** location.
- 3) Reinstall the telephone base, and secure it with its four captive screws.

#### NOTES:

1. To enable Busy Override tone and Camp-on Ring tones over the handset or headset of a DKT2010-SD, DKT2020-SD, DKT2020-S model, hold down the **Redial** button and press the up **Vol** button. To block the tone, hold down the **Redial** button and press the down **Vol** button.
2. For this to function properly with headsets, make sure the OCA strap or R607 is cut on the HHEU PCB and the HHEU strap is cut on the telephone (see Paragraph 3.32).

### 3.80 External Power Straps

**3.81** Digital telephones equipped with options such as Integrated Data Interface Units and ADMs require two-pair wiring or external power to operate efficiently at the maximum-allowed distance from the key service unit (KSU). Two-pair wiring or external power is also necessary for maximum cable run lengths for digital telephones that are connected to systems that must operate with reserve power. (See Table 8-D in Section 100-816-208 for reference.)

Each Digital telephone has two external power straps which must be cut for external power when the cabling of the telephone is connected to an external AC/DC power supply. Cut these straps in accordance with the following procedure:

- 1) Loosen the four captive screws securing the telephone base (Figure 6-1), and remove the base.
- 2) Depending on the telephone, refer to Figure 6-7, 6-8, or 6-9 and locate the **EX.POW** straps, **W101** and **W102**. Cut these straps.
- 3) Reinstall the telephone base, and secure it with its four captive screws.

**NOTE:**  
Refer to Section 100-816-208 for external AC/DC power supply ordering information and installation instructions.

### 3.90 DKT2000 Add-On-Module Installation

3.91 See Paragraph 7 in this chapter.

## 4 ELECTRONIC TELEPHONE UPGRADE OPTIONS (DK16 Only)

4.00 This section describes how to upgrade and configure electronic telephones for features and options.

### 4.10 Off-hook Call Announce Upgrade (HVSU2 or HVSU/HVSI)

4.11 Electronic telephones must be equipped with either the HVSU2 subassembly or the combined HVSU and HVSI subassemblies to receive Off-hook Call Announce (OCA) calls. These telephones also require three-pair wiring to receive OCA, instead of the standard two-pair. Telephones making OCA calls do not require an upgrade or extra wire pair.

4.12 **HVSU2 Upgrade Installation.** Install the HVSU2 in accordance with the following steps:

- 1) Loosen the four captive screws securing the telephone base (Figure 6-1), and remove the base.
- 2) Position the HVSU2 on the standoffs inside the base, and secure with the two provided screws (Figure 6-12).

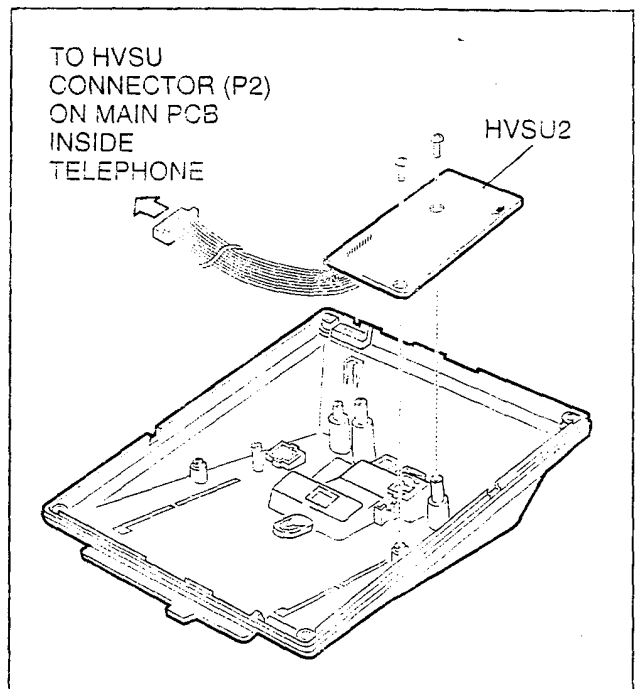


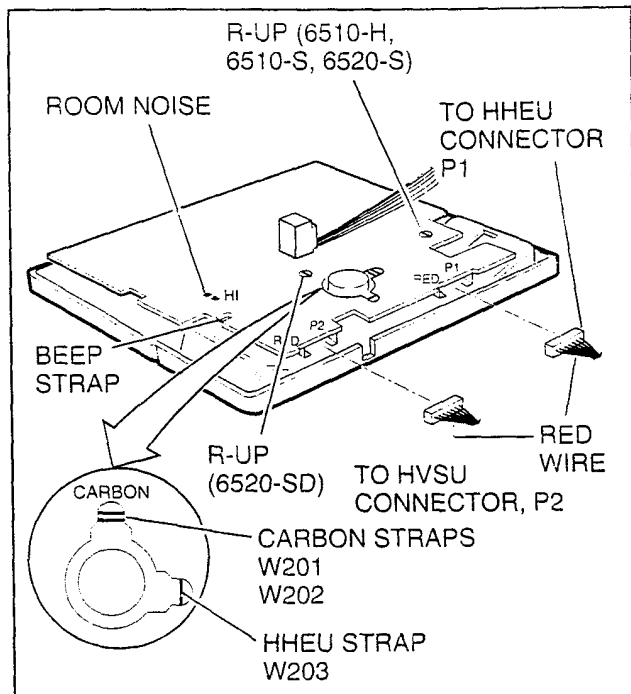
FIGURE 6-12  
HVSU2 INSTALLATION FOR ELECTRONIC  
TELEPHONES

- 3) Connect the HVSU2 wire plug to the **P2** connector on the printed circuit board (PCB) in the telephone (Figure 6-13).

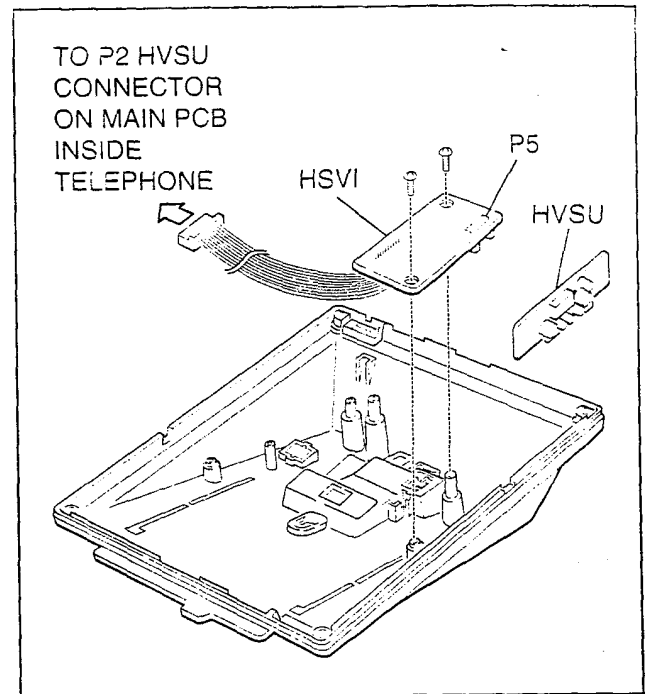
4.13 **HVSU/HVSI Upgrade Installation.** Install the HVSU/HVSI subassemblies in accordance with the following steps:

- 1) Loosen the four captive screws securing the telephone base (Figure 6-1), and remove the base.
- 2) Align the **P5** connector on the HVSI subassembly with the receptacle on the HVSU subassembly (Figure 6-14). Apply firm, even pressure to the PCBs to ensure that the connectors mate properly (they should click).

**NOTE:**  
Exercise care when assembling the HVSU to the HVSI to prevent damage to the connector pins; also, verify that the HVSU is aligned with the silk-screened image on the HVSI.



**FIGURE 6-13**  
**ELECTRONIC TELEPHONE PCB CONNECTIONS**



**FIGURE 6-14**  
**HVSU/HVSI INSTALLATION FOR ELECTRONIC TELEPHONES**

- 3) Position the HVSU/HVSI subassembly on the standoffs inside the base, and secure with the two screws provided (Figure 6-14).
- 4) Connect the HVSU/HVSI subassembly wire plug to the **P2** connector on the electronic telephone PCB (Figure 6-13).
- 5) Reinstall the electronic telephone base, and secure it with its four captive screws.

#### 4.20 Loud Ringing Bell/Headset Upgrade (HHEU)

**4.21** The Loud Ringing Bell/Headset upgrade (HHEU) enables an external speaker (HESB) and/or a headset to be connected to the electronic telephone. The HESB serves as a Loud Ringing Bell when connected to a telephone.

##### NOTES:

1. There are two types of HHEU: the HHEU1 (which has four versions, V.1 ~ V.4) and the HHEU2.

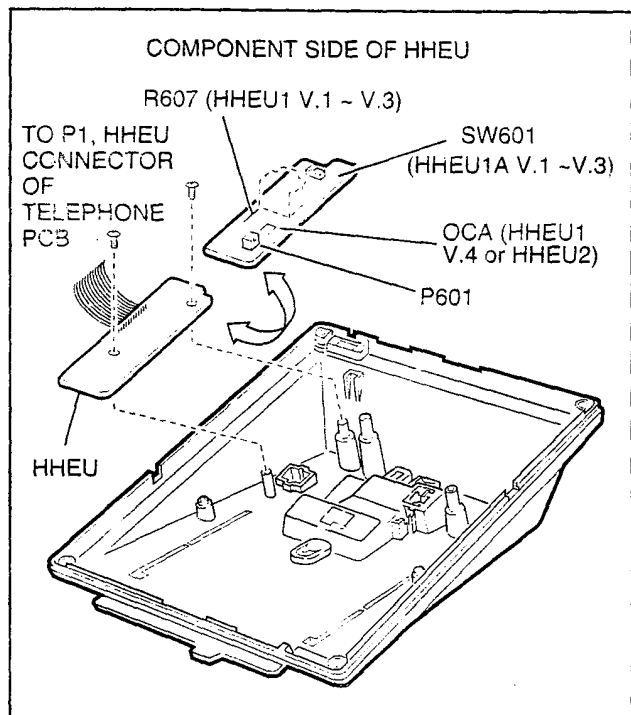
2. Only electronic telephones equipped with an HHEU2 can be wall mounted. The HHEU2 is identical to the V.4 HHEU1, except that the HHEU2 has longer wires to accommodate wall mounting.
3. A Toshiba HESC-65 or HESC-65A cable is required to connect the HHEU in an electronic telephone to the HESB. Refer to Section 100-816-207 for HESB installation procedures.
4. All HHEU versions and types, except for V.1 HHEU1, are compatible with the Off-hook Call Announce upgrades (HVSU2 and HVSU/HVSI).

**4.22 HHEU Upgrade Installation.** Install the HHEU upgrade in accordance with the following steps:

- 1) Loosen the four captive screws securing the telephone base (Figure 6-1), and remove the base.
- 2) Using a screwdriver or other suitable tool, remove the plastic tab located on the back

the base (Figure 6-1). The HHEU modular connector for the headset will be accessed through this opening.

- 3) If using a **V.3** or earlier HHEU1, set the **SW601** switch to the **HEADSET** position for HESB and/or headset connection (Figure 6-15). This switch is not on either the **V.4** HHEU1 or the HHEU2, because the operation is automatic with these subassemblies.
- 4) Connect the HESC-65 or HESC-65A cable (either one) to **P601** of the HHEU if the Loud Ringing Bell option is required (Figure 6-11). Refer to Section **100-816-207** for HESB installation procedures.
- 5A) For the **V.3** or earlier HHEU1: If only the headset is connected to the HHEU, cut both sides of the **R607** resistor on the HHEU (Figure 6-15) and then remove the resistor to eliminate electrical contact.



**FIGURE 6-15**  
**HHEU INSTALLATION FOR ELECTRONIC**  
**TELEPHONES**

**NOTE:**

*Do not cut the **R607** resistor if connecting an HESB to the HHEU for the Loud Ringing Bell—even if a headset is also installed on the HHEU.*

- 5B) For the **V.4** HHEU1 or the HHEU2: If only the headset is connected to the HHEU, cut the **OCA** strap (Figure 6-15).

**NOTE:**

*Do not cut the **OCA** strap if connecting an HESB to the HHEU for the Loud Ringing Bell—even if a headset is also installed on the HHEU.*

- 6) Position the HHEU subassembly on the standoffs inside the base (Figure 6-15), and secure with the two provided screws.
- 7) Connect the HHEU subassembly wire plug to the **P1** connector on the electronic telephone PCB (Figure 6-13).
- 8) Cut the **HHEU** strap on the telephone PCB (Figure 6-13).

**NOTE:**

*The HHEU strap must be replaced if the HHEU PCB is removed from the telephone.*

- 9) Reinstall the telephone base, and secure it with its four captive screws.
- 10) To adjust the volume of the HESB Loud Ringing Bell: Call the telephone connected to the HESB, and adjust the volume control on the back of the HESB and the ring volume control on the telephone.

#### 4.30 Carbon Headset/Handset Straps

**4.31** If a carbon-type handset or headset is connected to the handset jack on the side of the 6500-series electronic telephone, two straps inside the telephone must be cut. Cut the straps in accordance with the following steps:

**NOTE:**

*It is not necessary to cut these straps if the headset is connected to the HHEU.*

- 1) Loosen the four captive screws securing the telephone base (Figure 6-1), and remove the base.
- 2) Refer to Figure 6-13, and locate the **CARBON** straps, **W201** and **W202**. Cut both straps.
- 3) Reinstall the telephone base, and secure it with its four captive screws.

#### 4.40 Beep Strap

**4.41** A "beep" sounds whenever a dialpad button or feature button is pressed on an electronic telephone. This beep can be eliminated with the following procedure:

- 1) Remove the four captive screws securing the telephone base to the telephone (Figure 6-1), and remove the base.
- 2) Locate and cut the **BEEP** strap on the telephone printed circuit board (PCB) (Figure 6-13).
- 3) Reinstall the electronic telephone base, and secure in place using the four captive screws.

#### 4.50 Microphone/Speaker Threshold (Speakers only)

**4.51** High ambient noise levels may cause the speaker on the electronic telephone speakerphone models (the EKT6510-S, the EKT6520-S, and the EKT6520-SD) to cut off frequently. To make these telephones less sensitive to noise and to prevent the cut-off, follow the steps below:

- 1) Remove the four captive screws securing the base to the telephone, and remove the base (Figure 6-1).
- 2) Locate the **ROOM NOISE** switch on the printed circuit board (PCB) inside the telephone, and push it carefully to the **HI** (high) position (Figure 6-13).
- 3) Reinstall the telephone base and secure in place using the four captive screws.

#### 4.60 Handset Receiver Volume-up Strap (Version 2 6500-series Telephones Only)

**4.61** For **Version 2 (V.2)** 6500-series electronic telephones only, the handset receiver volume can be increased six decibels (db) by cutting a strap inside of the telephone. Cut the strap in accordance with the following steps:

- 1) Remove the four captive screws securing the telephone base to the telephone, and remove the base (Figure 6-1).
- 2) Locate the **R-UP** strap on the printed circuit board (PCB) inside the telephone, and cut it (Figure 6-13).
- 3) Reinstall the telephone base, and secure in place using the four captive screws.

### 5 DIRECT STATION SELECTION CONSOLE/SYSTEM CONNECTION (DK16 Only)

**5.01** STRATA DK16 systems configured with just a Base Unit can support one Direct Station Selection Console, and systems with the optional Expansion Unit can support two consoles. There are two types of consoles: the DDSS console and the HDSS console. The DDSS console can be connected to designated digital telephone circuits, and the HDSS console can only be connected to designated PEKU circuits. This section provides instructions on how to install both types of consoles.

#### 5.10 DDSS Console Connections

**5.11** The DDSS console, which can operate with a digital or electronic telephone (preferably an LCD model), can connect only to Circuit 8 of the Base Unit digital telephone circuit set or Circuit 8 of the PDKU. Standard twisted single-pair or two-pair jacketed telephone cable (maximum 1000 feet, 303 meters) is used for the connection. To accommodate the DDSS console connection, the instrument end of the cable should be terminated in a modular station connector block (RJ-11). Refer to Wiring Diagrams, Section **100-816-208**, for wiring interconnecting details, including cable length limitations (see Table 8-D).

**NOTE.**

1. *DDSS console cable runs must not have the following:*
  - Cable splits (single or double)
  - Cable bridges (of any length)
  - High resistance or faulty cable splices
2. *See Section 100-816-208 for secondary protection information.*

**CAUTION!**

*When installing the DDSS cable, do not run parallel to and within 3 feet of an AC power line. AC power lines should be crossed at right (90°) angles only. In particular, avoid running station wire pairs near devices that generate electrical noise, such as neon or fluorescent light fixtures.*

**5.12 DDSS Console Configuration.** The following considerations should be made when installing DDSS consoles:

- DDSS consoles can connect only to Circuit 8 of the Base Unit digital telephone circuit set or Circuit 8 of the PDKU.
- A maximum of two DDSS consoles can be installed per system equipped with an Expansion Unit.
- DDSS consoles can operate with an attendant electronic telephone, as well as with a digital one.
- A KCDU will not support a DDSS.

**5.13 DDSS Programming Overview  
Program 03**

- Code 64 identifies the slots that support DDSS consoles.

**Program 28**

- Assigns DDSS console(s) to telephones.

**Program 29**

- Assigns button functions for DDSS consoles.

**5.20 HDSS Console Connections**

**5.21** The HDSS console must be connected to the data pairs of circuits 7 and 8 on a PEKU in the Expansion Unit (via the MDF) with standard two-pair twisted, jacketed telephone cable. To accommodate the connection, the instrument end of the HDSS console cable should be terminated in a

modular station connector block (RJ-11). Refer to Wiring Diagrams, Section 100-816-208, for wiring/interconnecting details. The overall length of the cable run from the Expansion Unit (KSU) to the HDSS console must not exceed 500 feet (152 meters), if using 24 AWG cable. The HDSS console can operate with either an electronic or digital telephone (preferably an LCD model).

**CAUTION!**

*When installing the HDSS console cable, do not run parallel to and within 3 feet of an AC power line. AC power lines should be crossed at right (90°) angles only. Avoid running HDSS console wire pairs near devices that generate electrical noise, such as neon or fluorescent light fixtures.*

**5.22 HDSS Console Configuration.** The following considerations should be made when installing an HDSS console:

- A PEKU PCB is required in the expansion unit for an HDSS console. (The **DSS** switch on the PEKU must be set to DSS.)
- Two PEKU ports are required for the HDSS console (always Circuits 7 and 8).
- The PESU does not support the HDSS console.
- A system must be configured with the Expansion Unit to support an HDSS console. Only one HDSS console can be installed in a system.

**5.23 HDSS Programming Overview  
Program 03**

- Codes 23 and 24 identify the slot that supports a PEKU that interfaces with the HDSS console.

**Program 28**

- Assigns HDSS console to a telephone.

**Program 29**

- Assigns individual button functions for the HDSS console.

**6 DOOR PHONE/LOCK CONTROL UNIT  
AND DOOR PHONE INSTALLATION**

**6.01** This section provides installation instructions for the digital door phone/lock control units (DDCB). It also includes installation instructions for the door phone (MDFB). Each DDCB can support as many as three door phones (MDFBs), or two MDFBs and one door lock.

*NOTE:*

*DK8 and DK16 do not support the HDCB.*

**6.02** DK8 and DK16 systems can be equipped with up to six MDFBs.

**6.03** For DK8, DDCBs can only connect to Circuit 3 (Port 02) and Circuit 4 (Port 03).

**6.04** For DK16, DDCBs can only connect to Ports 04 and 12. DDCBs can only connect to Circuit 5 (Port 04) of the Base Unit and/or Circuit 1 (Port 12) of a PDKU or KCDU in the Expansion Unit.

*NOTE:*

*DDCBs cannot connect to the QSTU, KSTU, PSTU, PESU or PEKU.*

### 6.10 DDCB and MDFB Cabling

**6.11** Refer to Section **100-816-208** for DDCB and MDFB wiring/interconnecting details. For door lock control installation procedures, refer to Section **100-816-208**. The length of the cable run from the key service unit (KSU) to the MDFB (via the DDCB) must not exceed 1,000 feet (305 meters), if using 24 AWG cable (see Table 8-D).

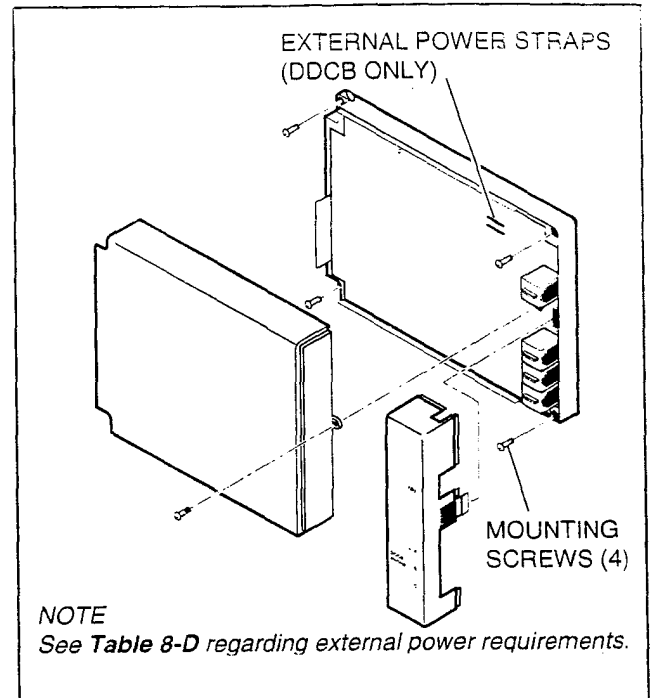
*NOTES:*

1. DDCB cable runs must not have the following:
  - Cable splits (single or double)
  - Cable bridges (of any length)
  - High resistance or faulty cable splices
2. See Section **100-816-208** for secondary protector information.

### 6.20 DDCB Wall Mounting

**6.21** The DDCB is designed to be mounted on a wall or other vertical surface. Mount the units in accordance with the following steps:

- 1) Locate the two mounting holes on the right-hand side on the DDCB (Figure 6-16).
- 2) Remove the side cover from the DDCB to expose the two left-hand mounting holes (Figure 6-16).
- 3) Position the DDCB adjacent to the key service unit (KSU) with regard to wiring needs.



**FIGURE 6-16**  
**DOOR PHONE (DDCB) INSTALLATION**

- 4) Secure the DDCB to the mounting surface with four one-inch panhead wood screws.

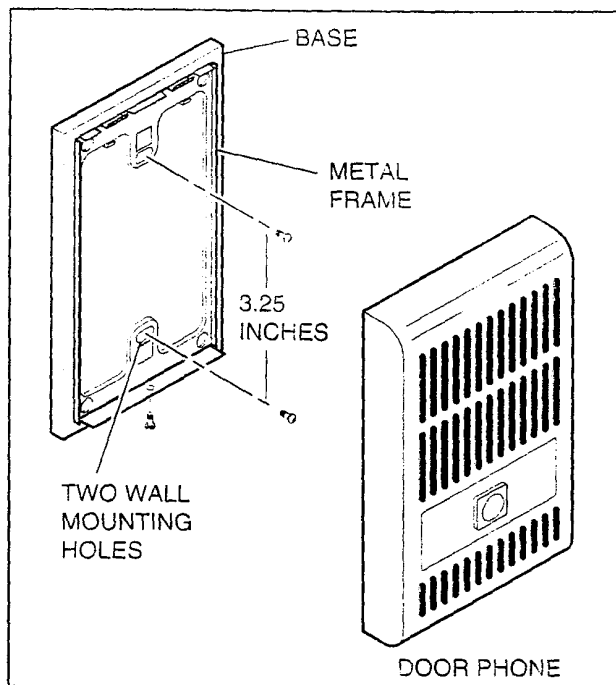
### 6.30 Door Phone (MDFB) Wall Mounting

**6.31** Mount door phones (MDFBs) to a wall or vertical surface in accordance with the following steps:

- 1) Remove the screw from the bottom of the cover. Detach the cover from the base and metal frame (Figure 6-17).
- 2) Position the metal frame and base to the mounting surface and secure with two one-inch panhead wood screws (Figure 6-17).
- 3) Attach cover to the metal frame and base and secure with the screw which was removed in Step 1.

**6.32 Door Phone Volume Control.** Adjust the ring and voice volume to the MDFB in accordance with the following procedure:

- 1) Remove the screw from the bottom of the MDFB cover. Detach the cover from the base and metal frame (Figure 6-17).



**FIGURE 6-17**  
**DOOR PHONE (MDFB) INSTALLATION**

- 2) The volume level is changed by a screw adjustment on the back of the MDFB. Turn the screw with a flat-tipped screwdriver while ringing the MDFB or while on a call with it. The volume level will change as the screw is turned.

#### 6.40 Door Phone/Lock Programming Considerations

6.41 The following programs should be considered when programming the system for door phones:

##### Program 39

- Assigns door phone and door lock buttons to digital telephones.

##### Program 77-1

- Assigns DDCBs to ports, door phone ringing over External Page during the NIGHT mode, and door lock activation time.

##### Program 77-2

- Used to busy out unused MDFB positions and to identify which DDCBs support the door lock option, and to set the door phone to ring one or five times.

##### Program 79

- Assigns door phone-to-station ringing assignments.

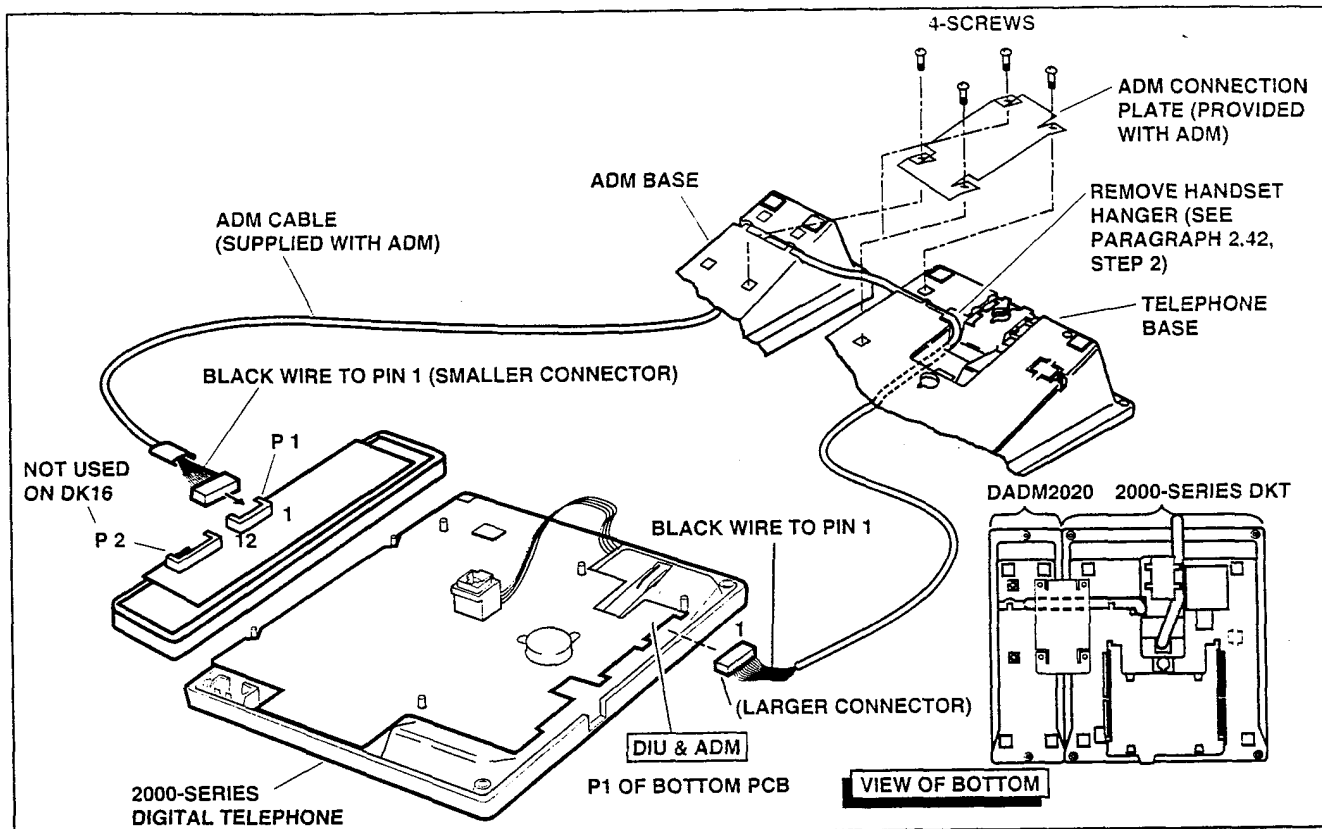
## 7 ADD-ON MODULE INSTALLATION

7.01 Install the Add-on Module (DADM 2020) to a 2000-series Digital Telephone (only) according to the steps that follow:

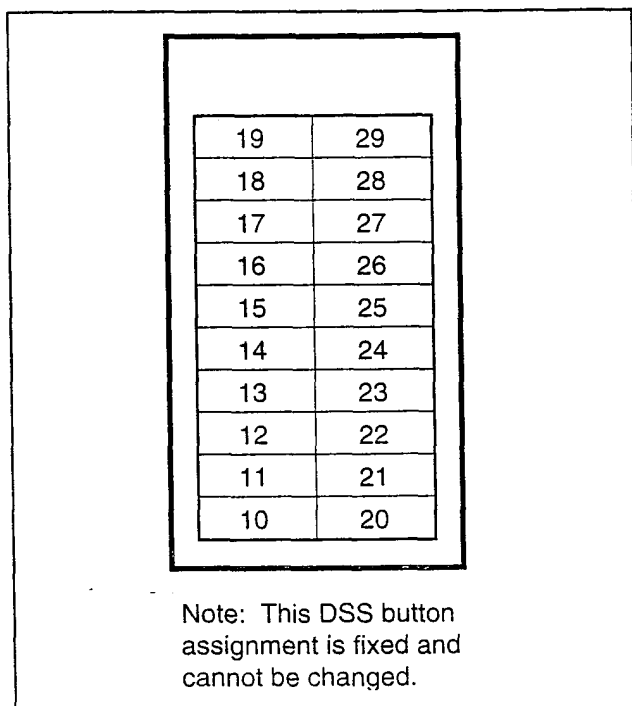
- 1) Loosen the four captive screws securing the 2000-series Digital Telephone base (Figure 6-1) and remove the base.
- 2) Remove the base handset hanger (Figure 6-1).
- 3) Loosen two captive screws securing ADM base and remove base.
- 4) Put on ADM cable (supplied with ADM) through telephone base and ADM base as shown in Figure 6-18.
- 5) Connect ADM cable connectors to P1 of ADM and P1 of DKT2000 telephone as shown in Figure 6-18.
- 6) Install base of ADM and telephone – tuck ADM cable into ADM and telephone base as necessary for proper length.
- 7) Secure ADM to telephone base with ADM connecting Plate (using four screws).
- 8) Check Table 8-D in Section 100-816-208; install 2-pair house cable (or external power) and 2-pair modular cord (supplied with ADM) if required to achieve maximum distance.

**7.11 ADM Programming.** ADMs do not require programming. The ADM provides 20 DSS buttons only (Figure 6-19) for the STRATA DK16, and 10 DSS buttons, 8 speed dial buttons, one night transfer button, and one all call page button (Figure 6-20) for the STRATA DK8. One ADM can be installed on any (or all) 2000-series telephone (16 max on DK16 or 8 max on DK8).

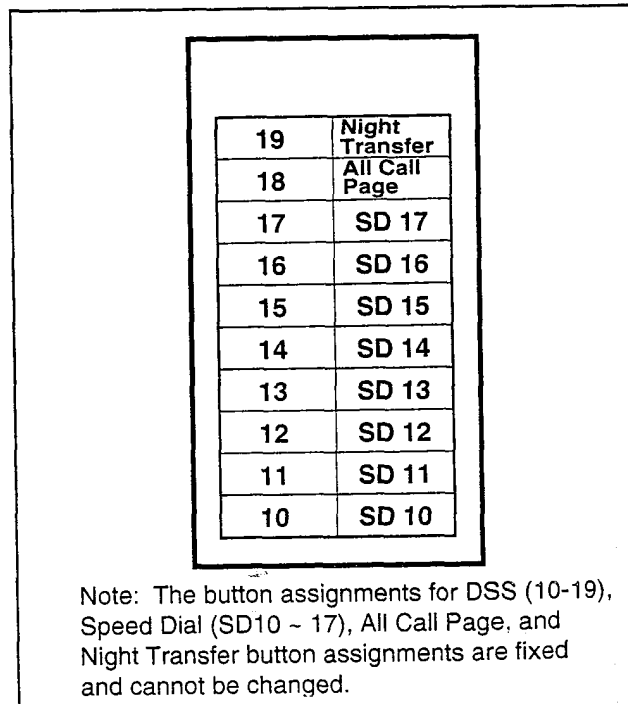




**FIGURE 6-18**  
**ADD-ON MODULE INSTALLATION**



**FIGURE 6-19**  
**DK16 ADD-ON MODULE DSS BUTTON ASSIGNMENTS**



**FIGURE 6-20**  
**DK8 ADD-ON MODULE DSS BUTTON ASSIGNMENTS**

# **Strata**<sup>®</sup> DK8 & DK16

## **INSTALLATION**

### **CHAPTER SEVEN**

### **PERIPHERAL INSTALLATION**

TABLE OF CONTENTS

PARAGRAPH	SUBJECT	PAGE
1	GENERAL .....	7-1
2	MUSIC-ON-HOLD/BACKGROUND MUSIC OPTIONS .....	7-1
2.10	DK8 and DK16 Music-on-Hold (MOH) Option .....	7-1
2.20	Background Music (BGM) Options .....	7-3
3	RELAY CONTROL OPTIONS .....	7-4
3.00	General .....	7-4
3.10	DK8 KSU and DK16 Base Unit Relay .....	7-7
3.20	DK16 Expansion Unit PIOUS and PIOUS Relays .....	7-7
3.30	DK16 Expansion Unit Night Transfer/Music-on-Hold Relay Options with PIOUS or PIOUS .....	7-9
4	EXTERNAL SPEAKER UNIT (HESB) OPTIONS .....	7-12
4.10	System Hardware Requirements .....	7-12
4.20	HESB Option Installation .....	7-12
5	EXTERNAL PAGE OPTIONS .....	7-19
5.00	System Hardware Requirements .....	7-19
5.10	External Page Option Installation .....	7-19
6	DK8 AND DK16 STATION MESSAGE DETAIL RECORDING (SMDR) PRINTER/CALL ACCOUNTING DEVICE OPTIONS .....	7-23
6.10	SMDR Hardware Requirements .....	7-27
6.20	SMDR Printer/Call Accounting Device Installation .....	7-27
7	VOICE MAIL OPTIONS .....	7-28
7.00	System Hardware Requirements .....	7-28
7.10	Toshiba VP Voice Messaging System .....	7-28
7.20	Customer-supplied Voice Mail Messaging Systems .....	7-30
8	DK16 ALARM SENSOR INSTALLATION .....	7-32
9	DK16 NIGHT RINGING OVER EXTERNAL ZONE PAGE .....	7-33
10	DATA INTERFACE UNIT INSTALLATION .....	7-34
10.00	General .....	7-34
10.10	Common DIU Connections .....	7-34
10.20	EIA Interface Leads (Signals) .....	7-35
10.30	DIP Switch Options .....	7-36
10.40	PDIU-DI to Personal Computer (PC) Installation .....	7-36
10.50	PDIU-DS to Printer Installation .....	7-37
10.60	PDIU-DS to Modem Installation .....	7-38
10.70	PDIU-DS Disassembly and Assembly .....	7-40
10.80	PDIU-DI/PDIU-DS Installation Tests .....	7-51
11	DK16 TWO-CO LINE EXTERNAL AMPLIFIED CONFERENCE .....	7-56
11.00	General .....	7-56

FIGURE LIST

FIGURE	TITLE	PAGE
7-1	DK8 AND DK16 MUSIC-ON-HOLD AND BACKGROUND MUSIC FUNCTIONAL DIAGRAM .....	7-2
7-2	DK16 BGM SOURCE/STANDARD TELEPHONE CIRCUIT PRECAUTION DIAGRAM .....	7-4
7-3	DK8 AND DK16 MUSIC SOURCE CONFIGURATION A .....	7-5
7-4	DK8 AND DK16 MUSIC SOURCE CONFIGURATION B .....	7-5
7-5	DK16 MUSIC SOURCE CONFIGURATION C .....	7-6

FIGURE LIST

FIGURE	TITLE	PAGE
7-6	DK16 PIOU RELAY CONTROL FUNCTIONAL WIRING DIAGRAM .....	7-8
7-7	DK16 PIOUS RELAY CONTROL FUNCTIONAL WIRING DIAGRAM .....	7-9
7-8	DK16 DOOR LOCK CONTROL OPTION (PIOU/PIOUS) .....	7-10
7-9	DK8 AND DK16 DOOR LOCK CONTROL OPTION (DDCB) .....	7-11
7-10	DK8 AND DK16 HESB/DIGITAL TELEPHONE WITH LOUD RINGING BELL WIRING .....	7-14
7-11	DK16 HESB/ELECTRONIC TELEPHONE WITH LOUD RINGING BELL WIRING .....	7-15
7-12	DK8 AND DK16 HESB/AMPLIFIED SPEAKER WIRING .....	7-17
7-13	DK8 AND DK16 HESB/TALKBACK AMPLIFIED SPEAKER WIRING .....	7-18
7-14	HESB WALL MOUNTING .....	7-19
7-15	DK8 AND DK16 PAGE AND SEPARATE BGM USING SAME AMPLIFIER .....	7-20
7-16	DK16 PIOU ZONE, PAGE/BGM/NIGHT RING (SEPARATE AMPLIFIERS) .....	7-21
7-17	DK16 PAGING WITH MULTIPLE AMPLIFIERS .....	7-22
7-18	DK16 NIGHT RINGING OVER ALL EXTERNAL PAGE ZONES .....	7-24
7-19	DK8 AND DK16 SMDR PRINTOUT EXAMPLES .....	7-26
7-20	DK8 AND DK16 PIOU/PIOUS SMDR CABLE CONNECTIONS .....	7-28
7-21	PIOU/PIOUS SMDR PORT (PROGRAM 97) DATA DUMP EXAMPLE .....	7-29
7-22	DK8 AND DK16 VOICE MAIL/AUTO ATTENDANT BLOCK DIAGRAM .....	7-30
7-23	DK16 ALARM SENSOR BLOCK DIAGRAM .....	7-33
7-24	DK8 OR DK16 DATA INSTALLATION EXAMPLE BLOCK DIAGRAM .....	7-41
7-25	DK8 AND DK16 PDIU-DI TO IBM AT-TYPE COMPUTER RS-232 CONNECTOR/CABLE CONNECTIONS .....	7-42
7-26	DK8 AND DK16 PDIU-DI TO IBM XT-TYPE COMPUTER, RS-232 CONNECTOR/CABLE CONNECTIONS .....	7-43
7-27	DK8 AND DK16 PDIU-DS TO TOSHIBA PRINTER, RS-232 CONNECTOR/CABLE CONNECTIONS .....	7-44
7-28	DK8 AND DK16 PDIU-DS TO HAYES-TYPE SMART MODEM, RS-232 CONNECTOR/CABLE CONNECTIONS .....	7-45
7-29	DK8 AND DK16 PDIU-DI/PDIU-DS MODULAR CABLE/RJ-45 ADAPTER CONNECTIONS .....	7-46
7-30	DK8 AND DK16 PDIU-DI/PDIU-DS MODULAR CORDS AND RJ-45/RS-232 ADAPTER PIN CONNECTIONS .....	7-47
7-31	DK8 AND DK16 PDIU-DS JUMPER PLUG OPTIONS/RS-232 CONNECTOR INFORMATION .....	7-48
7-32	DK8 AND DK16 PDIU-DI/PDIU-DS SW1 DIP SWITCH INFORMATION .....	7-49
7-33	DK8 AND DK16 PDIU-DS DISASSEMBLY/ASSEMBLY DIAGRAM .....	7-50
7-34	DK8 AND DK16 PC TO PC TEST CALL USING AT COMMANDS .....	7-51
7-35	DK8 AND DK16 PC TO PRINTER TEST CALL USING MANUAL DIALING .....	7-52
7-36	DK8 AND DK16 INTERNAL PC TO EXTERNAL PC TEST CALL USING AT COMMANDS .....	7-53
7-37	DK8 AND DK16 EXTERNAL PC TO INTERNAL PC TEST CALL USING AT COMMANDS .....	7-54
7-38	DK8 AND DK16 PC AUTO DIAL VOICE CALL TEST .....	7-56
7-39	DK16 AMPLIFIED TWO-CO LINE CONFERENCE AND/OR AMPLIFIED DISA FUNCTIONAL WIRING DIAGRAM .....	7-57

## 1 GENERAL

**1.00** This chapter provides procedures necessary to connect optional peripheral equipment to the STRATA DK8 or DK16. The installation instructions for each peripheral option include hardware requirements, printed circuit board (PCB) configuration, interconnection/wiring requirements, and programming considerations, as applicable.

**1.01** Peripheral equipment is connected to the Base Unit itself and PCBs located in the Base Unit and Expansion Unit on the DK16. On the DK8, peripheral equipment connects to the KSU. Refer to Section 100-816-204 for Key Service Unit installation instructions, PCB installation instructions, and PCB configuration information for the DK8. Refer to Section 100-816-205 for Base Unit and Expansion Unit installation instructions, PCB installation instructions, and PCB configuration information for the DK16.

**1.02** Wiring diagrams for each peripheral are located in this chapter.

## 2 MUSIC-ON-HOLD/BACKGROUND MUSIC OPTIONS

**2.00** STRATA DK8 and DK16 systems provides a Music-on-Hold option for CO lines and digital, electronic (DK16 only) and standard telephones connected to the system. A variety of Background Music options are also provided (refer to Figure 7-1).

### 2.10 DK8 and DK16 Music-on-Hold (MOH) Option

**2.11** An external music source—such as a tape player or tuner—can be connected to the RCA jack (labeled MOH) on the STRATA DK8 or DK16. The MOH source can be controlled (on/off) by a relay option set in **Program 77-1**. The DK8 KSU and DK16 Base Unit relay can control the MOH source, or the DK16 night bell. The MOH source and MOH relay contact specifications are:

- **MOH Source Specifications**
  - Input Impedance: 600 ohms
  - Input Voltage (recommended levels)
    - Minimum: 0.14 VRMS (-15 dBm)
    - Maximum: 0.77 VRMS (0 dBm)

- **Relay Contact Specifications**
  - Voltage: 24VDC maximum
  - Current: 1 ampere maximum

### **IMPORTANT NOTICE!** **MUSIC-ON-HOLD**

*In accordance with U.S. Copyright Law, a license may be required from the American Society of Composers, Authors, and Publishers (ASCAP), or other similar organization, if copyrighted music is transmitted through the Music-on-Hold feature of this telecommunications system. Toshiba America Information Systems, Inc., hereby disclaims any liability arising out of the failure to obtain such a license.*

**2.12 Music-on-Hold Installation.** Install the Music-on-Hold option in accordance with the following steps (refer to Figure 7-1):

- 1) Connect the external music source to the MOH RCA jack on the DK8 KSU or DK16 Base Unit.
- 2) Rotate the MOH volume control (**VR1**) on the Base Unit to adjust Music-on-Hold volume: clockwise increases volume; counterclockwise decreases volume. Listen to the CO line on-hold when setting MOH to the proper volume.
- 3A) If MOH relay control is required in DK8, the MOH relay is selected in **Program 77-1**. Follow program instructions to make selection. This will short pins 42 and 17 of the DK8 KSU or DK16 Base Unit amphenol connector when MOH is activated by a CO line on hold.
- 3B) If MOH relay control is required in DK16, the Base Unit or the PIOUS/PIOU relay may be selected in **Program 77-1**. Follow Program instruction to make the selection.
- 4A) Set PIOUS jumper plug **P11** to **MAKE** or **BREAK** position as required:
  - **MAKE (M)**—Shorts the normally open contacts (pins 9 and 34) when MOH is activated.
  - **BREAK (B)**—Opens the normally closed contacts (pins 9 and 34) when MOH is activated.

INSTALLATION-PERIPHERALS  
 SECTION 100-816-207  
 MARCH 1993

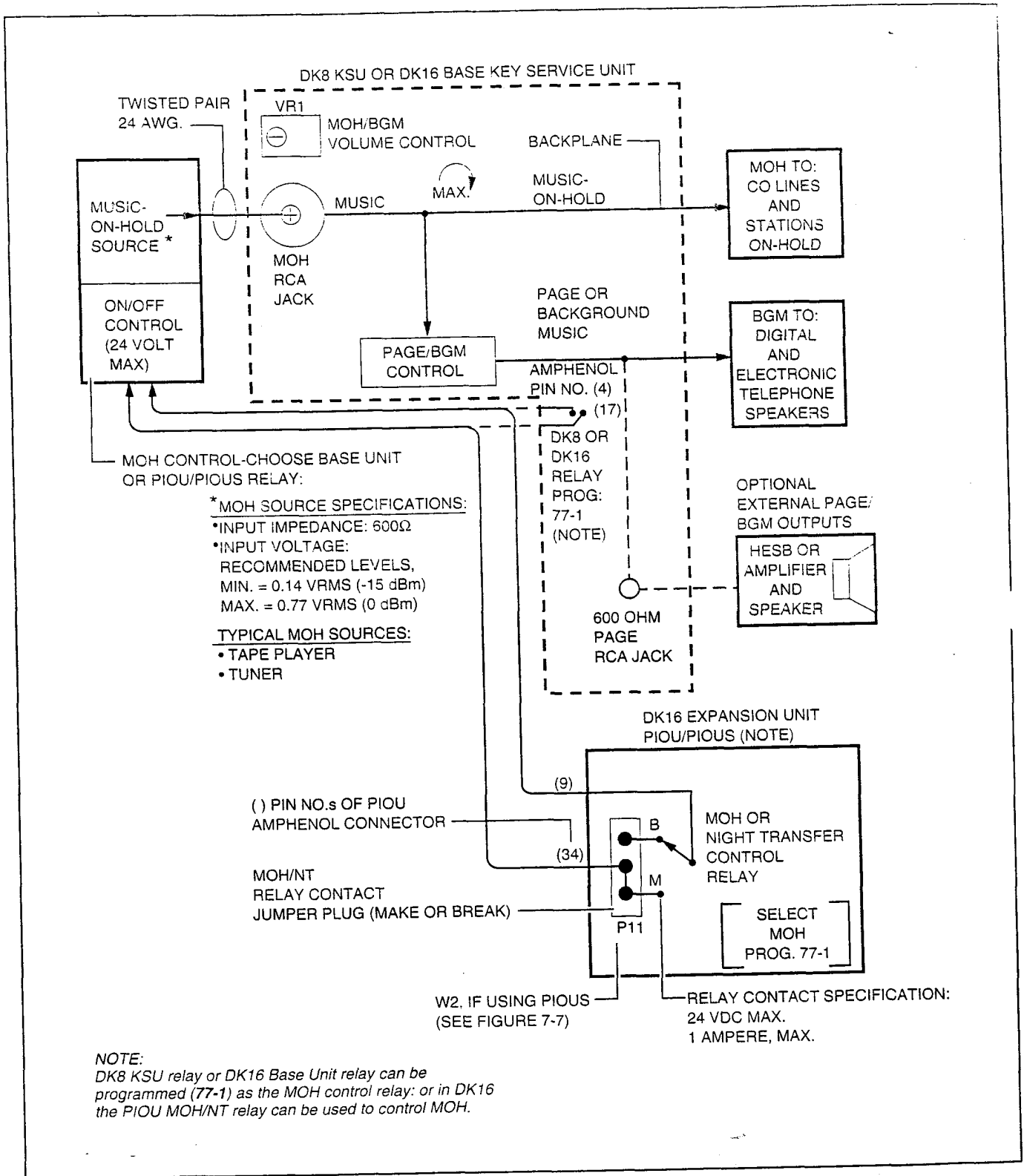


FIGURE 7-1  
 DK8 AND DK16 MUSIC-ON-HOLD AND BACKGROUND MUSIC FUNCTIONAL DIAGRAM  
 (SEE MDF WIRING DIAGRAM FOR DETAILS)

- 45) Solder PIOUS jumper W2 to MAKE or BREAK position if required:
- **MAKE (M)**—Shorts the normally open contacts (NHT and NHR) when any CO line is in the hold condition.
  - **BREAK (B)**—Opens the normally closed contacts (NHT and NHR) when any CO line is in the hold condition.
- 5) For DK8 and DK16, MOH is sent to any station or CO line that is on hold.
- 6) MOH is also applied through the Page/Background Music (BGM) control to provide BGM to electronic/digital telephone speakers and external page (refer to Paragraph 2.20).

## 2.20 Background Music (BGM) Options

**2.21** The Background Music options allow music to play over optional external speakers (external page system) and/or electronic and/or telephone speakers. The system allows BGM to be configured any of the three ways described below:

- 1) Configuration A (DK8 and DK16)—one music source: This configuration allows BGM and MOH to share the same music source (see Figure 7-3). With this configuration, the MOH/BGM music source is connected to the MOH RCA jack on the DK8 KSU or DK16 Base Unit. The music source is sent to CO lines/stations on hold, to electronic/digital telephone speakers with BGM turned on (via **Intercom 481** or **Tel Set Music** button), and to the external page system via the 600 ohm RCA jack on the DK8 KSU or DK16 Base Unit.
- 2) Configuration B—two music sources: This configuration allows the MOH source to be connected to the MOH jack on the DK8 KSU or DK16 Base Unit (as in Configuration A) and a separate BGM source to be connected to a designated circuit on either a QSTU (circuit 2, Port 19), PEKU (circuit 3), PESU (circuit 8), PSTU, or KSTU (circuit 4)—see Figure 7-4. With this configuration, the MOH source is sent only to CO lines/stations on hold, while the BGM source is sent directly to electronic/digital telephone speakers and to the external page system via the 600 ohm RCA jack on the DK8 KSU or DK16 Base Unit.

- 3) Configuration C (DK16 only)—three music sources: This configuration allows the MOH source to be connected to the MOH jack on the Base Unit (as in Configuration A). The digital or electronic telephone BGM source is connected to a designated circuit on the PEKU, PESU, PSTU, or KSTU (as in Configuration B), and a separate BGM source is sent to the external page speakers via the PIOUS Zone relay contacts (see Figure 7-5). When a separate BGM source is connected to the PIOUS, two customer-supplied amplifiers are required to drive the external speakers. One amplifier (1) drives the speakers for BGM when page is idle and the other amplifier (2) drives the speakers during page.

**2.22 MOH Source as Background Music Installation (DK8 and DK16).** Install the MOH/Background Music option in accordance with the following steps (refer to Figure 7-1):

- 1) Ensure that the Music-on-Hold option is installed in accordance with Paragraph 2.12.
- 2) The output of the MOH RCA jack is applied to the 600 ohm PAGE RCA jack output.
- 3) When using an HESB or external amplifier for paging/BGM, adjust volume using the HESB or amplifier volume control.

**2.23 Alternate BGM Source Installation** A BGM source can be connected to either a QSTU, PSTU, KSTU, PEKU, or PESU. This music will be sent to all electronic/digital telephone speakers and to the external page system via the 600 ohm PAGE RCA jack on the DK8 KSU or DK16 Base Unit. This BGM source is separated from the MOH source connected to the MOH RCA jack on the DK8 KSU or DK16 Base Unit. Connect the BGM source to the QSTU, PSTU, KSTU, PEKU or PESU in accordance with the following steps (Figure 7-4):

**NOTE:**

*If connecting the BGM source to the KSTU, PSTU, or QSTU PCB, a telephone adaptor matching/isolation transformer should be installed between the source and the PCB to protect the source from potentially ruinous voltages generated by the PCB (see Figure 7-2).*

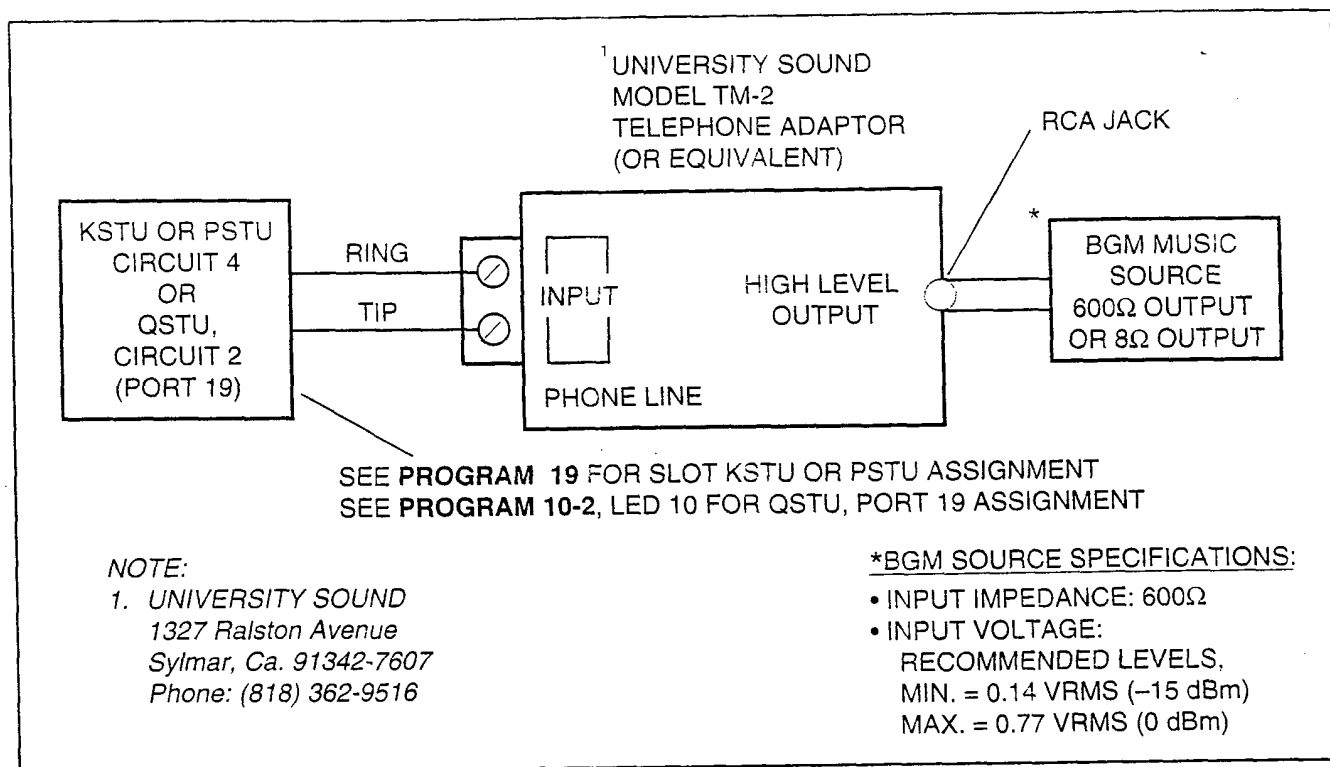
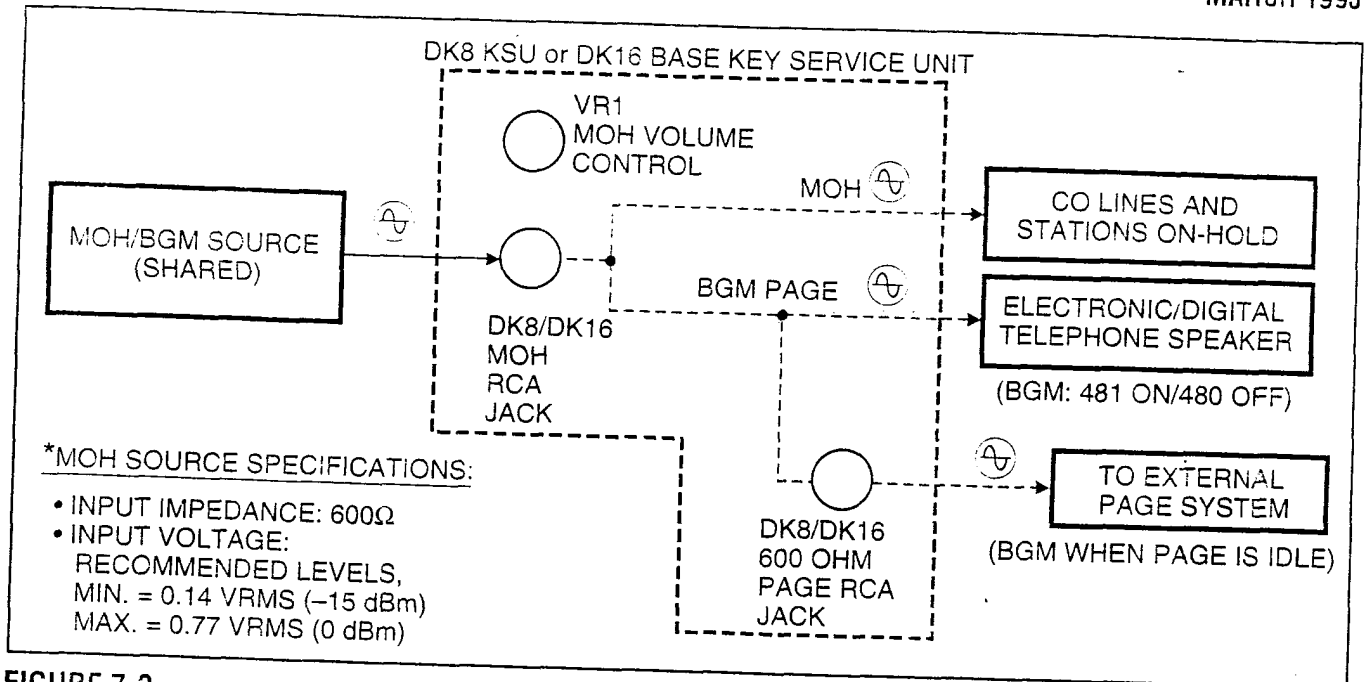


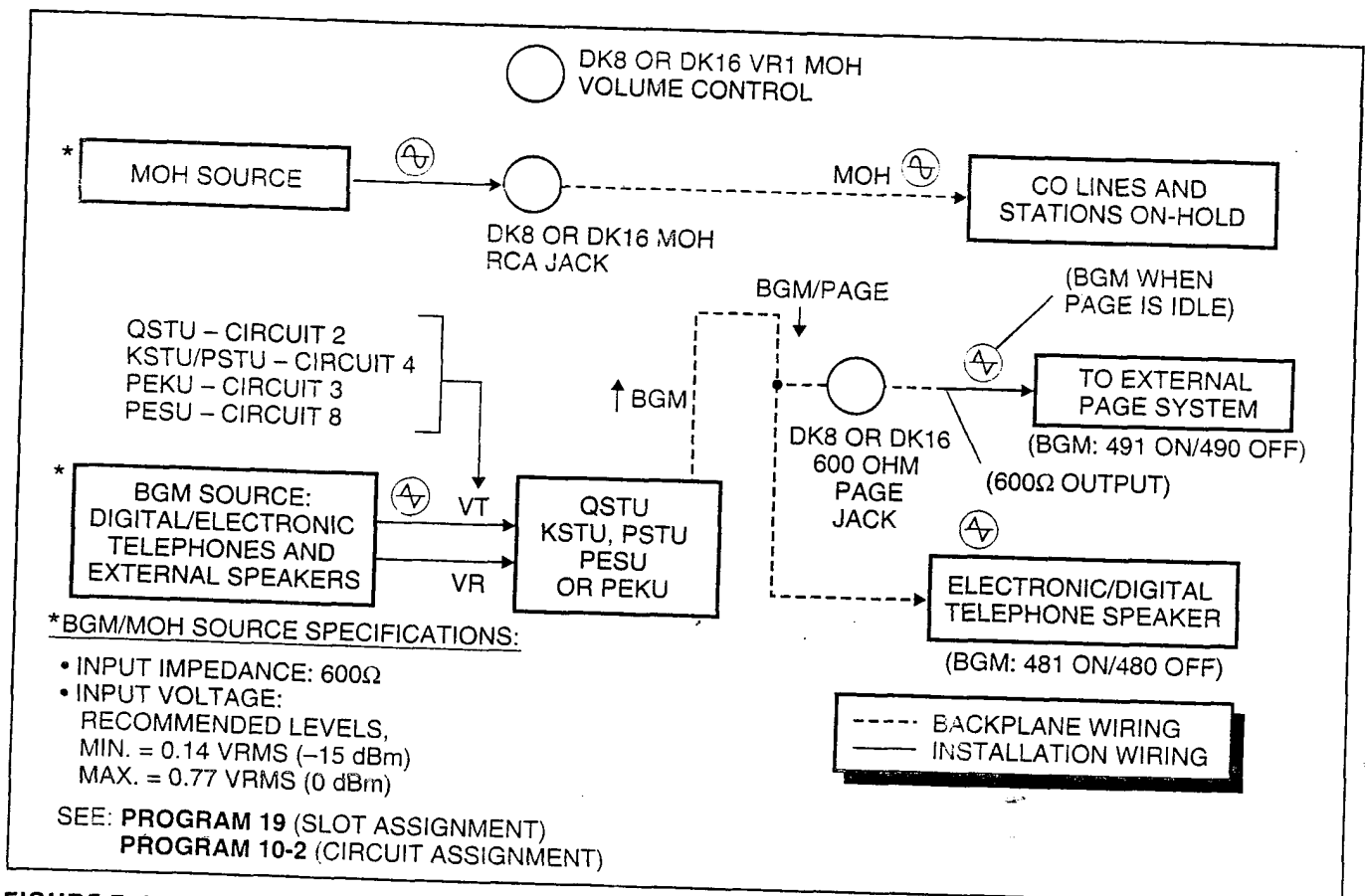
FIGURE 7-2  
DK16 BGM SOURCE/STANDARD TELEPHONE CIRCUIT PRECAUTION DIAGRAM

- 1) For DK16, enter the programming mode and identify the BGM slot number in Program 19 of the printed circuit board (KSTU, PSTU, PEKU, and PESU) which the BGM source will be connected to.
  - 2) Connect the BGM source to the tip and ring of the appropriate circuit of the BGM PCB: KSTU or PSTU (circuit 4), PEKU (circuit 3), and PESU (circuit 8). In Program 10-2, use LED 09 or 10 to specify the circuit number PEKU or PESU. KSTU or PSTU does not require Program 10-2 assignment.
  - 2A) For DK8, enter the programming mode and set LED 10 to on in Program 10-2. This assigns QSTU circuit 2, Port 19 as the BGM source for the system. You must cycle system power for Program 10-2 to take effect.
  - 3) If BGM is connected to PEKU or PESU, cut W5 on the PEKU or W7 on the PESU PCB that BGM is connected to.
  - 4) Using the BGM source's volume control, adjust the BGM volume to the desired level while listening to BGM via an digital or electronic telephone speaker and/or the external page speakers. When BGM is sent to external speakers via the 600 ohm RCA jack PCB, use the external amplifier volume control to balance the BGM and page volume levels.
- 2.24 External Background Music Installation.**  
The external background music options are closely associated with the external paging options. Refer to Paragraph 5 for external paging amplifier installation.
- ### 3 RELAY CONTROL OPTIONS
- #### 3.00 General
- 3.01** The DK8 KSU and DK16 Base Unit provides one relay, and the PIOUS and PIOUS each provide two relays that control peripheral options.





**FIGURE 7-3**  
**DK8 AND DK16 MUSIC SOURCE CONFIGURATION A**



**FIGURE 7-4**  
**DK8 AND DK16 MUSIC SOURCE CONFIGURATION B**

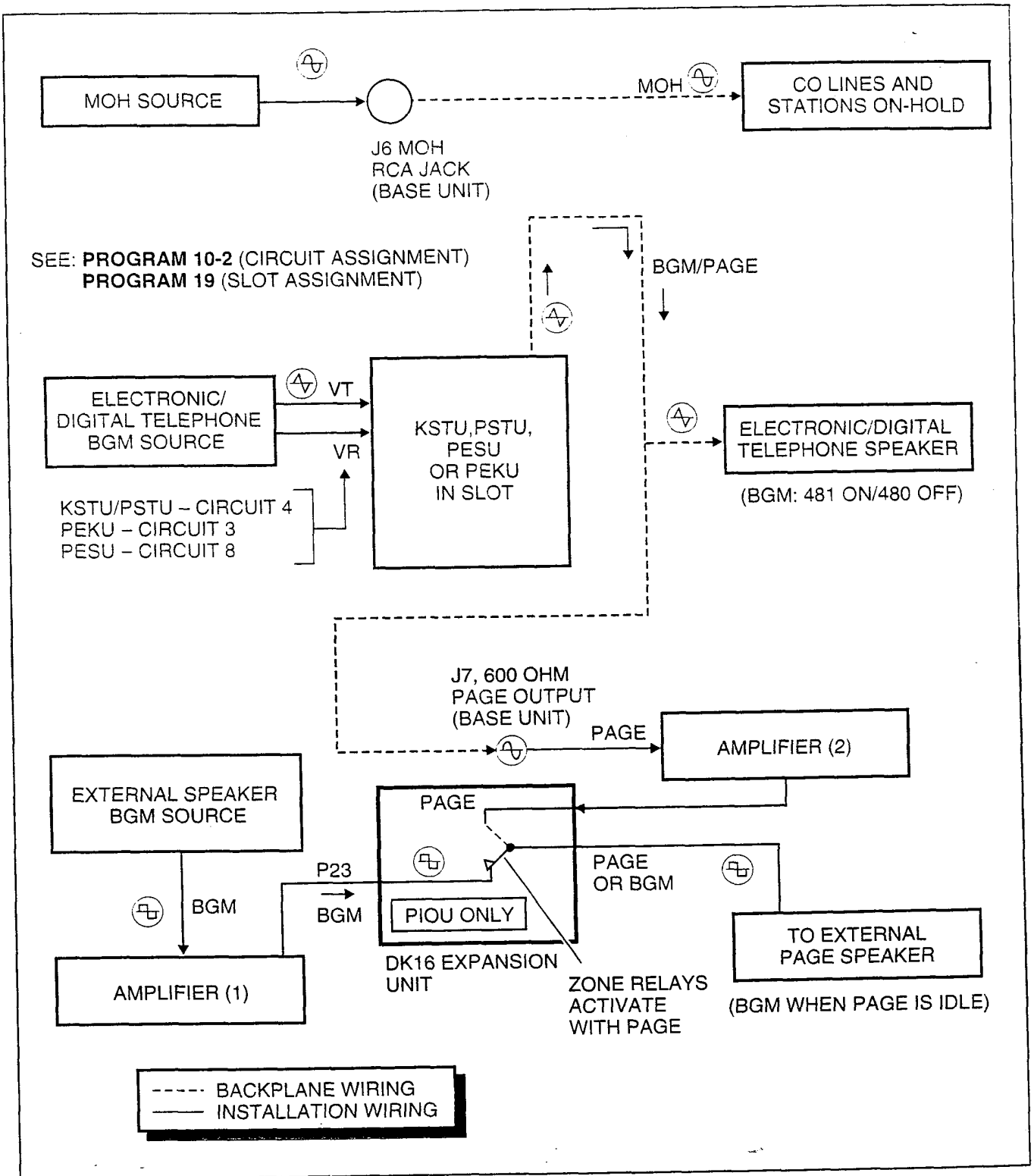


FIGURE 7-5  
 DK16 MUSIC SOURCE CONFIGURATION C

### 3.10 DK8 KSU and DK16 Base Unit Relay

3.11 The DK8 KSU or DK16 Base Unit Relay can be programmed for one of three options:

- BGM mute
- Night transfer
- MOH source control

These options are set in **Program 77-1** (LED 01 and 02). Only one option is allowed per installation. However, in the DK16, these options can be supplemented with PIOUS/PIOUS relay options. Refer to Chapter 8 for wiring/interconnecting details. Electrical specifications for the relay contacts are as follows:

#### Voltage

- 24VDC maximum

#### Current

- 1 ampere maximum
- Normally open—closed when activated

### 3.20 DK16 Expansion Unit PIOUS and PIOUS Relays

3.21 The Expansion Unit via the PIOUS or PIOUS provides two additional relays that control peripheral options (see Figures 7-6, 7-7, 8-23, and 8-25).

- Door Lock Relay/BGM mute
- Night Transfer/Music-on-Hold Relay

#### NOTE:

*The above relay options are available in conjunction with the Base Unit relay option.*

3.22 Each relay may be configured as normally open (make) or normally closed (BREAK). Electrical specifications for the relay contacts are as follows:

#### Voltage

- 24VDC maximum

#### Current

- 1 ampere maximum

#### CAUTION!

**Do not connect relays directly to 120VAC power source.**

3.23 **Door Lock Control (PIOUS or PIOUS).** Configure the PIOUS or PIOUS for the door lock control

function in accordance with the following steps (refer to Figure 7-6 and 7-7):

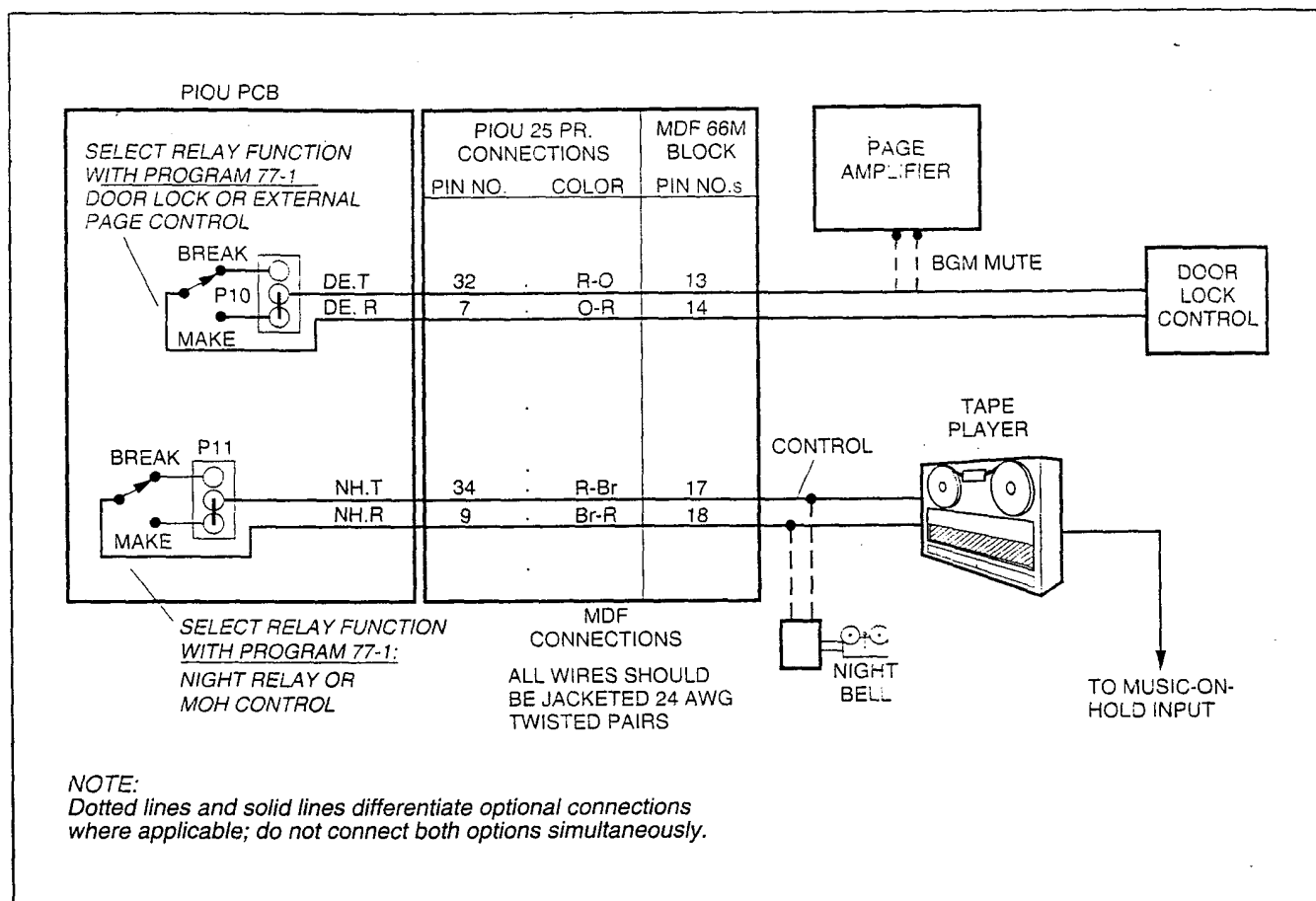
#### NOTE:

*Only one door lock control is available using an optional interface PCB (PIOUS or PIOUS), because only one interface PCB is allowed.*

- 1) Access **Program 77-1**. Set **LED 07** for the door lock control function.
- 2) Access **Program 77-1**. Set **LED 20** to **OFF** for a 3-second door lock activation time, or set **LED 20** to **ON** for a 6-second door lock activation time.
- 3A) Set the **P10** jumper plug on the PIOUS to the **MAKE** or **BREAK** position, as required:
  - **MAKE**—Shorts the normally open contacts (pins 7 and 32) when a station's door lock button is pressed.
  - **BREAK**—Opens the normally closed contacts (pins 7 and 32) when a station's door lock button is pressed.
- 3B) Solder the **W1** jumper plug on the PIOUS to the **MAKE** or **BREAK** position as required:
  - **MAKE**—Shorts the normally open contacts (DET and DER) when a station's door lock button is pressed.
  - **BREAK**—Opens the normally closed contacts (DET and DER) when a station's door lock button is pressed.
- 4) Refer to Figure 7-8 for wiring/interconnecting details. Connect the PIOUS or PIOUS to the MDF as required for the door lock control function.

### 3.24 DK8 and DK16 DDCB Door Lock Control.

In addition to the door lock control provided by the PIOUS or PIOUS (DK16 only), each door phone/lock control box (DDCB) installed provides one door lock control. Only two DDCBs can be installed in a system: On DK8 a DDCB can be connected to Circuit 3 (Port 02) and/or Circuit 4 (Port 03); on DK16 a DDCB can be connected to the circuit 5 (Logical Port 04) of the Base Unit Digital telephone circuit set and to circuit 1 of the KCDU or PDKU

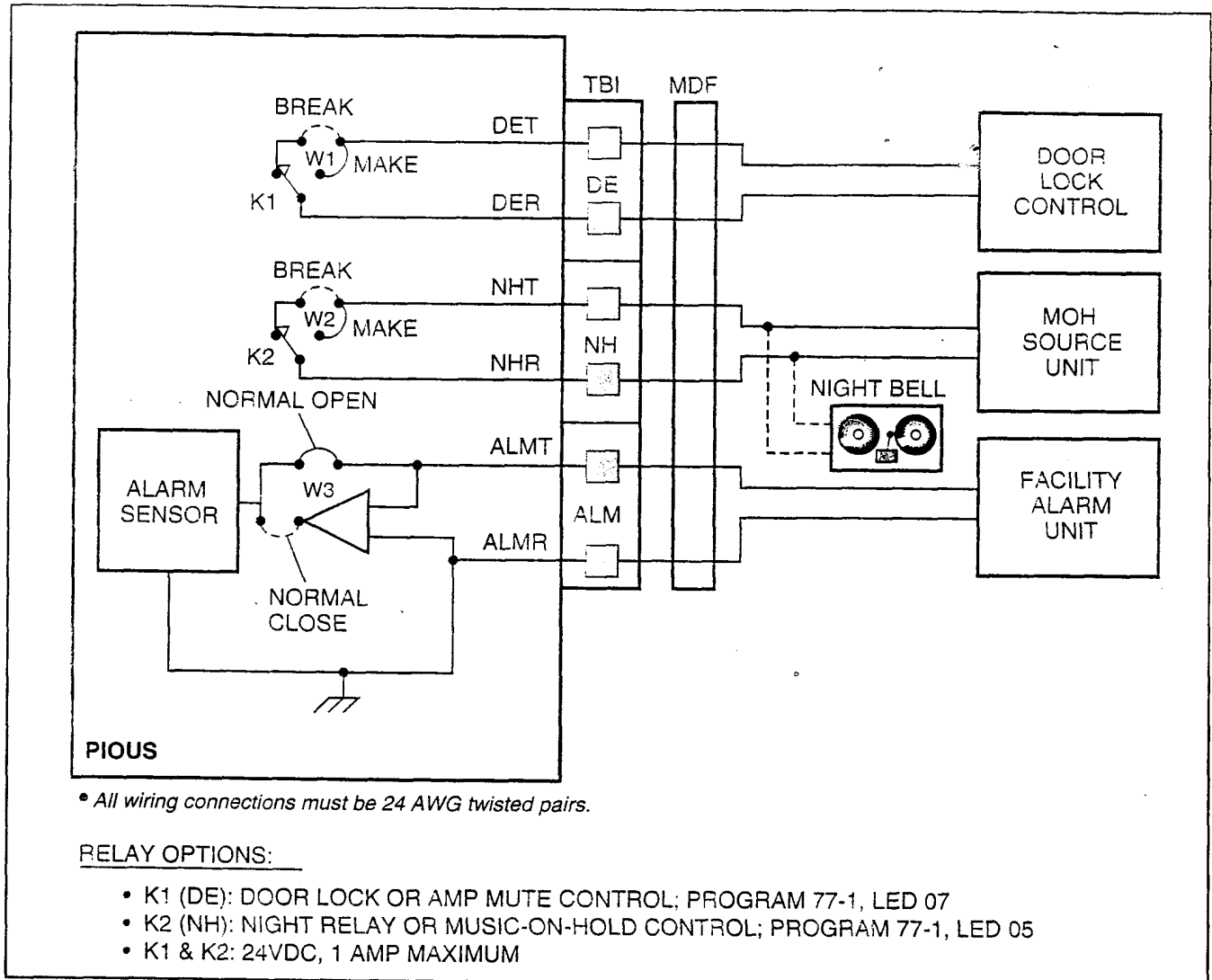


**FIGURE 7-6**  
**DK16 PIU RELAY CONTROL FUNCTIONAL WIRING DIAGRAM**

(Logical Port 12) in the Expansion Unit. Each DDCB door lock control installed reduces the system door phone capacity of six by one. Any electronic or digital telephone can be equipped with a button for each of the door locks. Install each DDCB door lock control as follows:

**DDCB Installation**

- 1) On DK8, connect applicable digital telephone circuit (Logical Port 02 or 03) to the DDCB KSU modular jack (see Figure 7-9 and Figure 8-4).
- 2) On DK16, connect the applicable digital telephone circuit (Logical Port 04 or 12) to the DDCB HKSU modular jack (see Figure 7-9 and Figure 8-4).
- 3) On the DDCB, set SW1 to the DOOR position, and SW2 to the LOCK position.
- 4) In **Program 77-1**, set the door unlock activation for three or six seconds, and enable the applicable port for DDCB connection, and specify if door phones should ring over external page at night.
- 5) In **Program 77-2**, enable the DDCB B-jack for door lock operation, and specify 1 or 5 rings when door button is pressed.
- 6) In **Program 79**, specify door phone ringing assignments.
- 7) In **Program 39**, assign Unlock Door buttons to the desired stations.
- 8) Check each Unlock Door button from each station: DDCB modular B-jack (pins 3 and 4) will momentarily close (three or six seconds) when the appropriate Unlock Door button is pressed.



**FIGURE 7-7**  
**DK16 PIOUS RELAY CONTROL FUNCTIONAL WIRING DIAGRAM**

### 3.25 Door Lock Assignments Guide

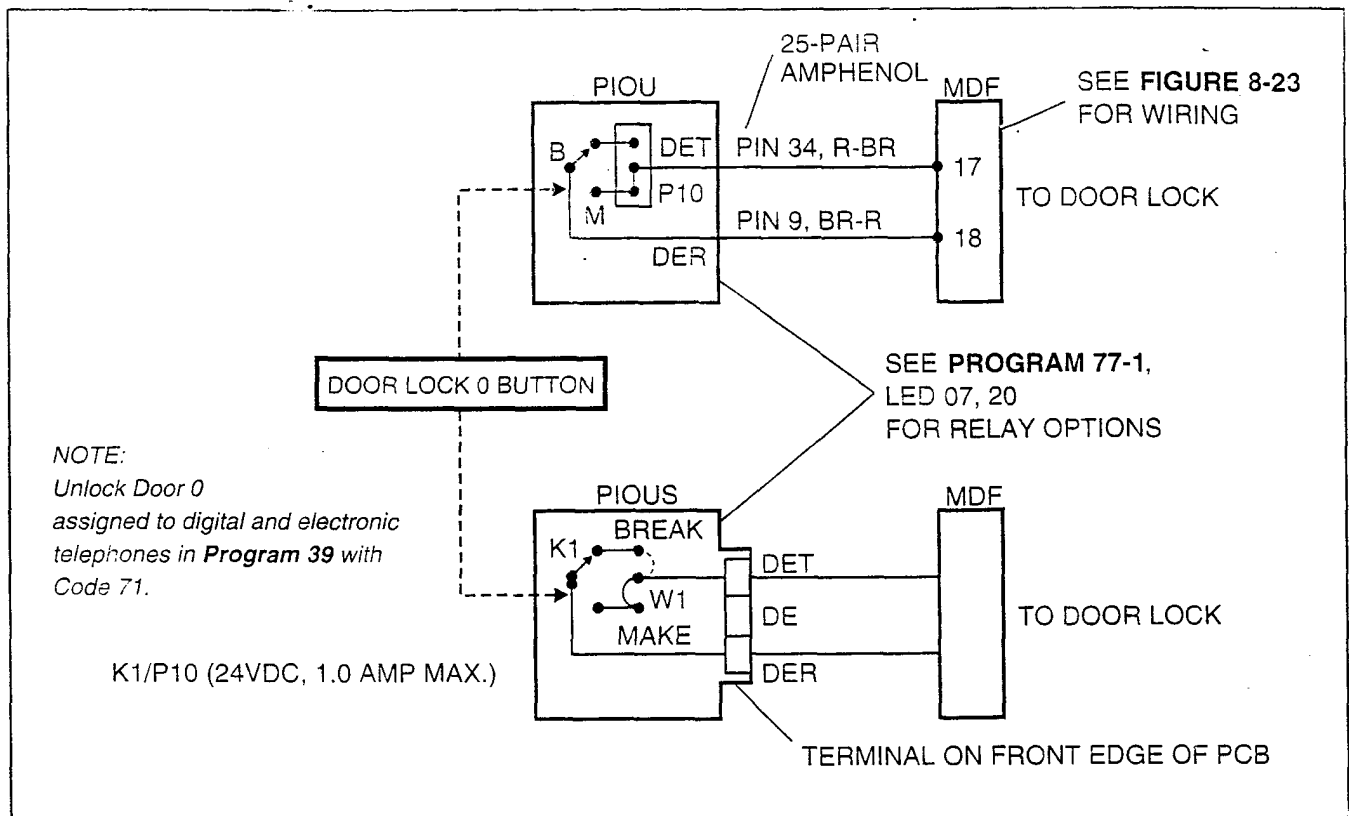
Host	Port No.	Door Lock No.	Prog. 39 Assignments
DK16 PIOUS/PIOUS	N/A	0 Unlock Door 0	Code 71
Ckt 5 DK16 Base Unit DDCB	04	1 Unlock Door 1	Code 72
Ckt 3 DK8 KSU DDCB	02	1 Unlock Door 1	
Ckt 1 Expansion Unit (PDKU or KCDU)	12	2 Unlock Door 2	Code 73
Ckt 4 DK8 KSU DDCB	03	2 Unlock Door 2	

*Note: CKT1 must be used in installing DDCB on KCDU or PDKU. (Must be in Port 12)*

### 3.30 DK16 Expansion Unit Night Transfer/ Music-on-Hold Relay Options with PIOUS or PIOUS

**3.31** The NHT/NHR relay may be programmed for either the night relay or the MOH relay function (refer to Figures 7-6 and 7-7). These functions can be provided in addition to the relay service provided by the Base Unit.

**3.32** When configured for the night transfer function with **Program 77-1**, the relay activates if the system is in the NIGHT mode. The relay may be



**FIGURE 7-8**  
**DK16 DOOR LOCK CONTROL OPTION (PIOU/PIOUS)**

programmed to activate continuously when the **Night Transfer 1** button (only) is set to NIGHT mode (for indirect answering machine control); or to pulsate at 1-second ON/3-seconds OFF (for a night bell) when incoming CO lines night ring over external page (**Program 78-13**) (**NT1** = tenant 1 CO lines; **NT2** = tenant 2 CO lines) per **Program 15**.

**3.33** When configured for the Music-on-Hold function with **Program 77-1**, the relay activates any time a CO line is on hold. In this configuration, the relay is normally used to control the Music-on-Hold source.

**3.34 DK16 Night Transfer Relay Control.** Configure the PIOU or PIOUS for the Night Transfer Relay function in accordance with the following steps (refer to Figures 7-6 and 7-7):

- 1) Access **Program 77-1**. Set **LED 05** to **OFF** to configure the Night/Hold Relay for the Night Relay function.

- 2) Access **Program 77-1**. Set **LED 06** to provide continuous or pulsating relay activation as follows:

- **OFF**—Programs the relay for continuous activation when **NT1** button (only) is set.
- **ON**—Programs the relay for pulsating activation when the **NT1** or **NT2** button is set to NIGHT mode and a tenant 1 or tenant 2 CO line rings.

**NOTE:**

*CO lines must be enabled in **Program 78-13** for the NT pulsating relay function.*

- 3) Access **Programs 87, 88, and 89** to set the CO lines that will activate the relay (when the system is in the NIGHT mode).
- 4) Access **Program 39** to program a **Night Transfer** button (**NT1** or **NT2**) on all telephones that are to transfer the system into the NIGHT mode.

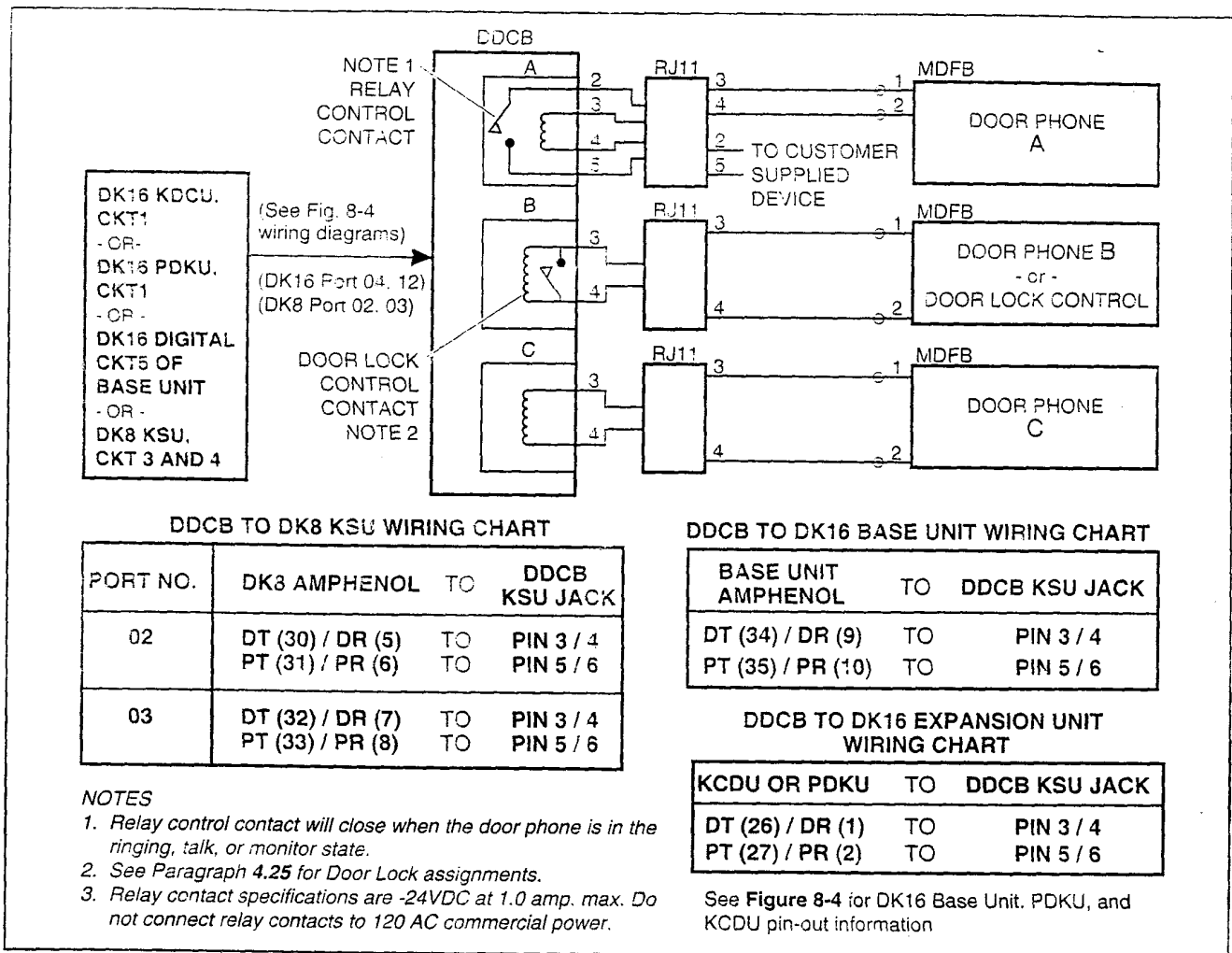


FIGURE 7-9  
DK8 AND DK16 DOOR LOCK CONTROL OPTION (DDCB)

- 5) Access **Programs 29-1 ~ 29-2** to program a **Night Transfer** button (**NT1** or **NT2**) on all DSS consoles that are to transfer the system into the NIGHT mode.
- 6) If tenant operation is required, access **Program 15** to set the CO lines for tenant 1 (**NT1**) or tenant 2 (**NT2**) operation.
- 7A) Set the **P11** jumper plug on the PIOUS to the **MAKE** or **BREAK** position, as required:
  - **MAKE**—Shorts the normally open contacts (pins 9 and 34) when the night relay is activated.
  - **BREAK**—Opens the normally closed contacts (pins 9 and 34) when the night relay is activated.
- 7B) Solder the jumper **W2** on the PIOUS to the **MAKE** or **BREAK** position, as required:
  - **MAKE**—Shorts the normally open contacts (NHT and NHR) when the night relay is activated.
  - **BREAK**—Opens the normally closed contacts (NHT and NHR) when night relay is activated.
- 8) Refer to Figures 7-6 and 7-7 for wiring/interconnecting details. Connect the PIOUS or PIOUS to the MDF as required for the night relay function.

**NOTE:**  
Door phones programmed to ring over external page in night mode (**Program 77-1**) do not activate the NT relay.

**3.35 DK16 Expansion Unit MOH Relay Control.** Configure the P10U or P10US for the MOH relay function in accordance with the following steps (refer to Figures 7-6 and 7-7):

- 1) Access **Program 77-1**. Set **LED 05** to **ON** to configure the Night/MOH relay for the MOH relay function.
- 2A) Set the **P11** jumper plug on the P10U to the **MAKE** or **BREAK** position, as required:
  - **MAKE**—Shorts the normally open contacts (pins 9 and 34) when any CO line is on hold.
  - **BREAK**—Opens the normally closed contacts (pins 9 and 34) when any CO line is on hold.
- 2B) Solder the **W2** jumper on the P10US to the **MAKE** or **BREAK** position, as required:
  - **MAKE**—Shorts the normally open contacts (NHT and NHR) when any CO line is on hold.
  - **BREAK**—Opens the normally closed contacts (NHT and NHR) when any CO line is in on hold.
- 3) Refer to Figures 7-6 and 7-7 for wiring/interconnecting details. Connect the P10U or P10US to the MDF as required for the MOH relay function.

#### 4 EXTERNAL SPEAKER UNIT (HESB) OPTIONS

**4.00 STRATA DK8 and DK16 systems** provide three options utilizing an HESB:

**4.01 DK8 and DK16 Loud Ringing Bell Option.** The Loud Ringing Bell option allows the voice first or ringing signal tone to be amplified without the use of other manufacturers' equipment. The voice first and ringing signal tones can be amplified on all 6500-series electronic telephones and 2000- and 1000-series digital telephones equipped with HHEU PCBs (refer to Section **100-816-206**). The HESB automatically turns off once the ringing call or voice first has been manually answered from the electronic or digital telephone. This turn-off feature prevents audio feedback problems.

**4.02 Amplified Speaker Option.** The Amplified Speaker option allows the HESB to be configured as a paging speaker. The HESB is connected to the 600 ohm Page RCA jack on the DK8 KSU or DK16 Base Unit to provide an amplified external speaker.

**4.03 Talkback Amplified Speaker Option.** The Talkback Amplified Speaker option allows a talkback speaker to be provided in areas where a telephone is not needed. In this configuration, the HESB is connected to the 600 ohm Page RCA jack on the DK8 KSU or DK16 Base Unit and is used as the amplifier and speaker. The door phone unit (MDFB) is connected to the HESB, and serves as a microphone to provide talkback operation. (The MDFB microphone is always on in this application so the pushbutton is inoperative, and the unit serves only as a microphone for talkback.)

*NOTE:*

*The 600 ohm Page RCA jack is two-way (duplex) and is compatible with most commercially available talkback amplifiers.*

#### 4.10 System Hardware Requirements

**4.11 System hardware requirements** vary depending on the HESB option selected. Refer to the following installation procedures for the system hardware requirements for each option.

#### 4.20 HESB Option Installation

**4.21 Loud Ringing Bell Installation.** Install the HESB Loud Ringing Bell option in accordance with the following procedures:

#### DK8 and DK16 HESB Installation for Digital Telephone Loud Ring Bell (Figure 7-10):

- 1) Connect a jumper between Terminals 2 and 10 on the HESB **TB1** terminal block.
- 2) Connect a jumper between Terminals 4 and 5 on the HESB **TB2** terminal block.

*NOTES:*

1. *HESB connections made in steps 3-5 may be accomplished using the HESB **VOICE** modular jack instead of the **TB1** terminal block.*



2. *Install an HHEU PCB and HESC-65A cable in the telephone per Section 100-816-206 before proceeding with Step 3.*
- 3) Connect Terminal 1 of the HESB **TB1** terminal block to the red (+) wire of the HESC-65A using a modular block.
- 4) Connect Terminal 2 of the HESB **TB1** terminal block to the green (-) wire of the HESC-65A using a modular block.
- 5) Connect Terminal 8 of the HESB **TB1** terminal block to the yellow (L2) wire of the HESC-65A cable using a modular block.
- 6) Connect the HACU-120 power supply's +12V lead to Terminal 1 of the HESB **TB2** terminal block, and connect the power supply's 0V lead to Terminal 2.
- 7) Plug the provided power cord into the power supply and to a 117VAC, 60Hz power source.
- 4) Connect Terminal 2 of the HESB **TB1** terminal block to the green (-) wire of the HESC-65 cable using a modular block.
- 5) Connect Terminal 3 of the HESB **TB1** terminal block to pin 3 of the electronic telephone's modular block (VOICE TIP).
- 6) Connect Terminal 4 of the HESB **TB1** terminal block to Pin 4 of the electronic telephone's modular block (VOICE RING).
- 7) Connect the HACU-120 power supply's +12V lead to Terminal 1 of the HESB **TB2** terminal block, and connect the power supply's 0V lead to Terminal 2.
- 8) Plug the provided power cord into the power supply and to a 117VAC, 60Hz power source.

**4.22 Loud Ringing Bell Test.** Test the Loud Ringing Bell installation in accordance with the following steps:

- 1) Make a CO or station call to the station configured for the loud ringing bell.
  - Ringing will be heard over the HESB.
- 2) Adjust the HESB volume control to the desired level. (Screwdriver adjustment on back of HESB and ring level control of associated telephone.)
- 3) If ringing is heard at the station, but not over the HESB, perform the following check while the station is ringing:
  - a) Using a suitable voltmeter, measure voltage across terminals 1 (+) and 2 (-) of the HESB **TB1** terminal block.
    - Voltage indication should be 4.5 ~ 5.0 VDC.

**DK16 HESB Installation for Electronic Telephone Loud Ring Bell (Figure 7-11):**

- 1) On the HESB **TB1** terminal block: connect a jumper between Terminals 6 and 7, and connect another jumper between Terminals 5 and 8.
- 2) On the HESB **TB2** terminal block, connect a jumper between Terminals 4 and 5.

**NOTES:**

1. *HESB connections made in steps 3-6 may be accomplished using the HESB VOICE modular jack instead of the TB1 terminal block.*
2. *Install an HHEU PCB and HESC-65 (or HESC-65A) cable in the telephone per Section 100-816-206 before proceeding with Step 3.*
- 3) Connect Terminal 1 of the HESB **TB1** terminal block to the red (+) wire of the HESC-65 cable using a modular block.

**NOTE:**

*Ringling stops once the call is manually answered. There should be NO voltage potential across terminals 1 and 2.*

- b) If voltage is not as specified during ringing, check that the telephone wiring connections to the HESB have been made properly (wires to terminals 1 and 2 of the HESB **TB1** terminal block may have been reversed).

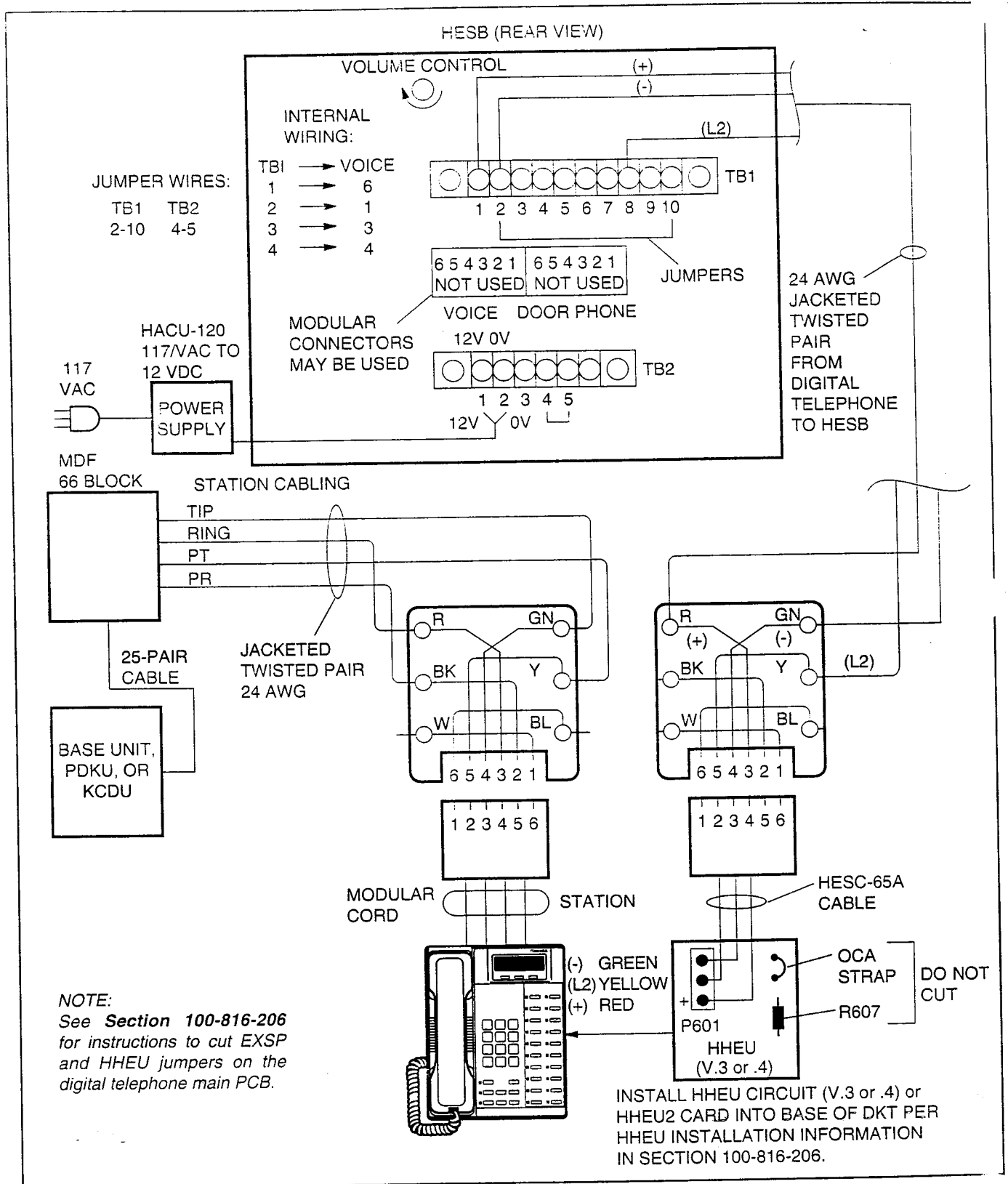


FIGURE 7-10  
 DK8 AND DK16 HESB/DIGITAL TELEPHONE WITH LOUD RINGING BELL WIRING

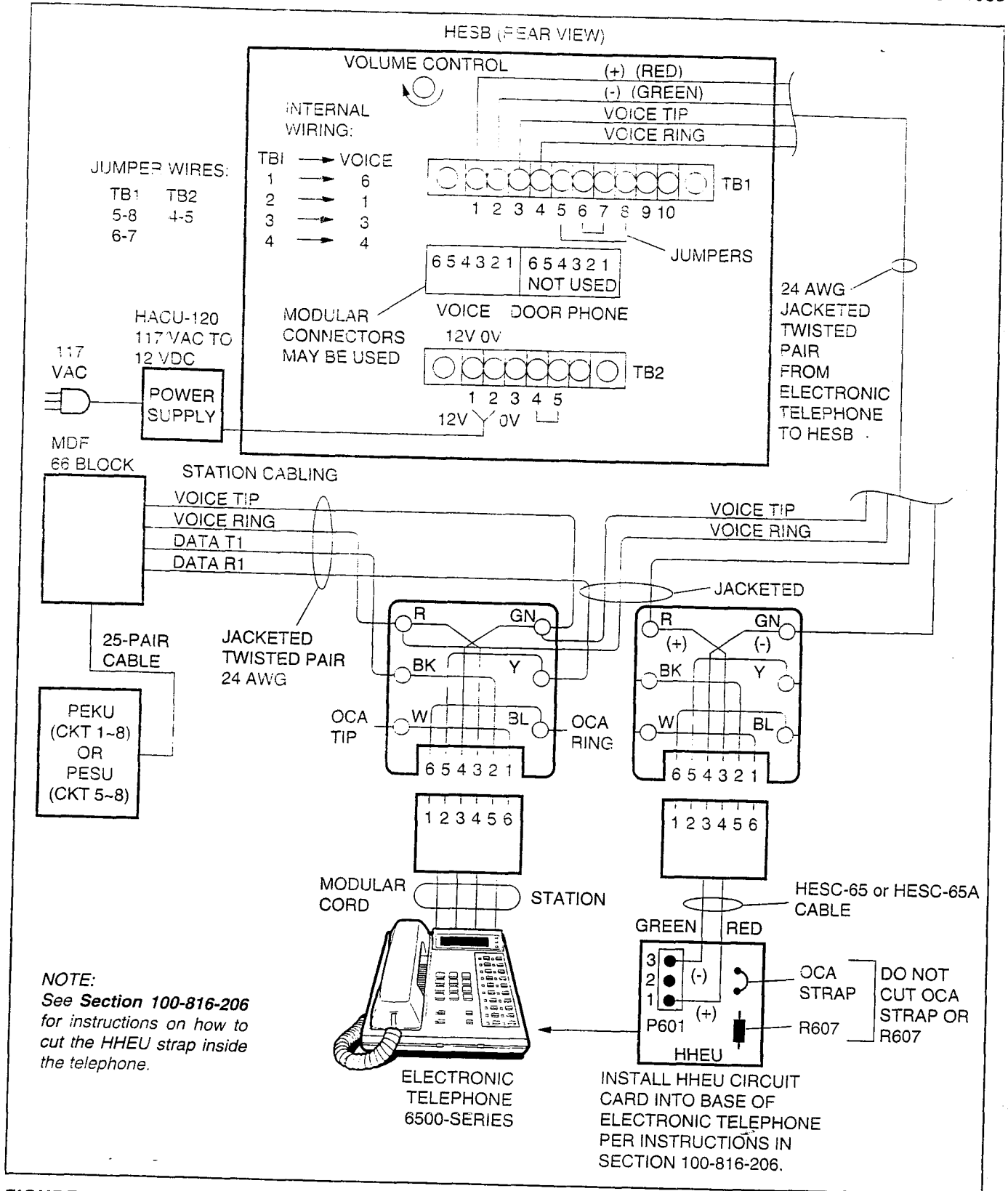


FIGURE 7-11  
DK16 HESB/ELECTRONIC TELEPHONE WITH LOUD RINGING BELL WIRING

INSTALLATION-PERIPHERALS  
SECTION 100-816-207  
MARCH 1993

**4.23 Amplified Speaker Installation.** Install the HESB Amplified Speaker option in accordance with the following steps (refer to Figure 7-12):

- 1) Connect a jumper between terminals 1 and 2 of the HESB **TB1** terminal block.
- 2) Connect a jumper between terminals 6 and 7 of the HESB **TB1** terminal block.
- 3) Connect a jumper between terminals 5 and 8 of the HESB **TB1** terminal block.
- 4) Connect a jumper between terminals 3 and 4 of the HESB **TB2** terminal block.
- 5) Connect a jumper between terminals 5 and 6 of the HESB **TB2** terminal block.
- 6) Connect the 600 ohm PAGE RCA jack output on the DK8 KSU or DK16 Base Unit to terminals 3 and 4 of the HESB **TB1** terminal block.
- 7) Connect the power supply's **+12V** lead to terminal 1 of the HESB **TB2** terminal block, and connect the **0V** lead to terminal 2.
- 8) Plug the provided power cord into the power supply and to a 117VAC, 60Hz power source.

**4.24 Amplified Speaker Test.** Test the amplified speaker installation in accordance with the following steps:

- 1) Make an external page.
  - Page should be heard over the HESB.
- 2) Adjust the HESB volume control to the desired level (screwdriver adjustment on back of HESB).

**4.25 HESB/MDFB Talkback Amplified Speaker Installation.** Install the HESB/MDFB Talkback Amplified Speaker option in accordance with the following steps (refer to Figure 7-13):

- 1) Connect a jumper between terminals 1 and 2 of the HESB **TB1** terminal block.
- 2) Connect a jumper between terminals 3 and 4 of the HESB **TB2** terminal block.

- 3) Connect a jumper between terminals 5 and 6 of the HESB **TB2** terminal block.

**NOTE:**

*HESB connections made in steps 4 ~ 7 may be accomplished using the HESB **VOICE and DOOR PHONE** modular jack instead of the **TB1** terminal block.*

- 4) Connect terminal 7 of the HESB **TB1** terminal block to pin L1 of the MDFB.
- 5) Connect terminal 8 of the HESB **TB1** terminal block to pin L2 of the MDFB.
- 6) Connect terminal 9 of the HESB **TB1** terminal block to pin 1 of the MDFB.
- 7) Connect terminal 10 of the HESB **TB1** terminal block to pin 2 of the MDFB.
- 8) Connect the 600 ohm PAGE RCA jack output from DK8 KSU or DK16 base unit to terminals 3 and 4 of the HESB **TB1** terminal block.
- 9) Connect the HACU-120 Power Supply's **+12V** lead to terminal 1 of the HESB **TB2** terminal block, and connect the **0V** lead to terminal 2.
- 10) Plug the provided power cord into the power supply and to a 117 VAC, 60Hz power source.

**4.26 Talkback Amplified Speaker Test.** Test the Talkback Amplified Speaker installation in accordance with the following steps:

- 1) Make an external page.
  - Page will be heard over the HESB.
- 2) Verify that someone speaking into the door phone can be heard at the paging station (with this application, pressing the door phone button is not required to talkback through the door phone).

**4.27 HESB Wall Mounting Instructions.** The HESB can be mounted to a wall or other vertical surface. Use the following instruction to mount the HESB (see Figure 7-14).

- 1) Find a suitable location on the mounting surface for the HESB.

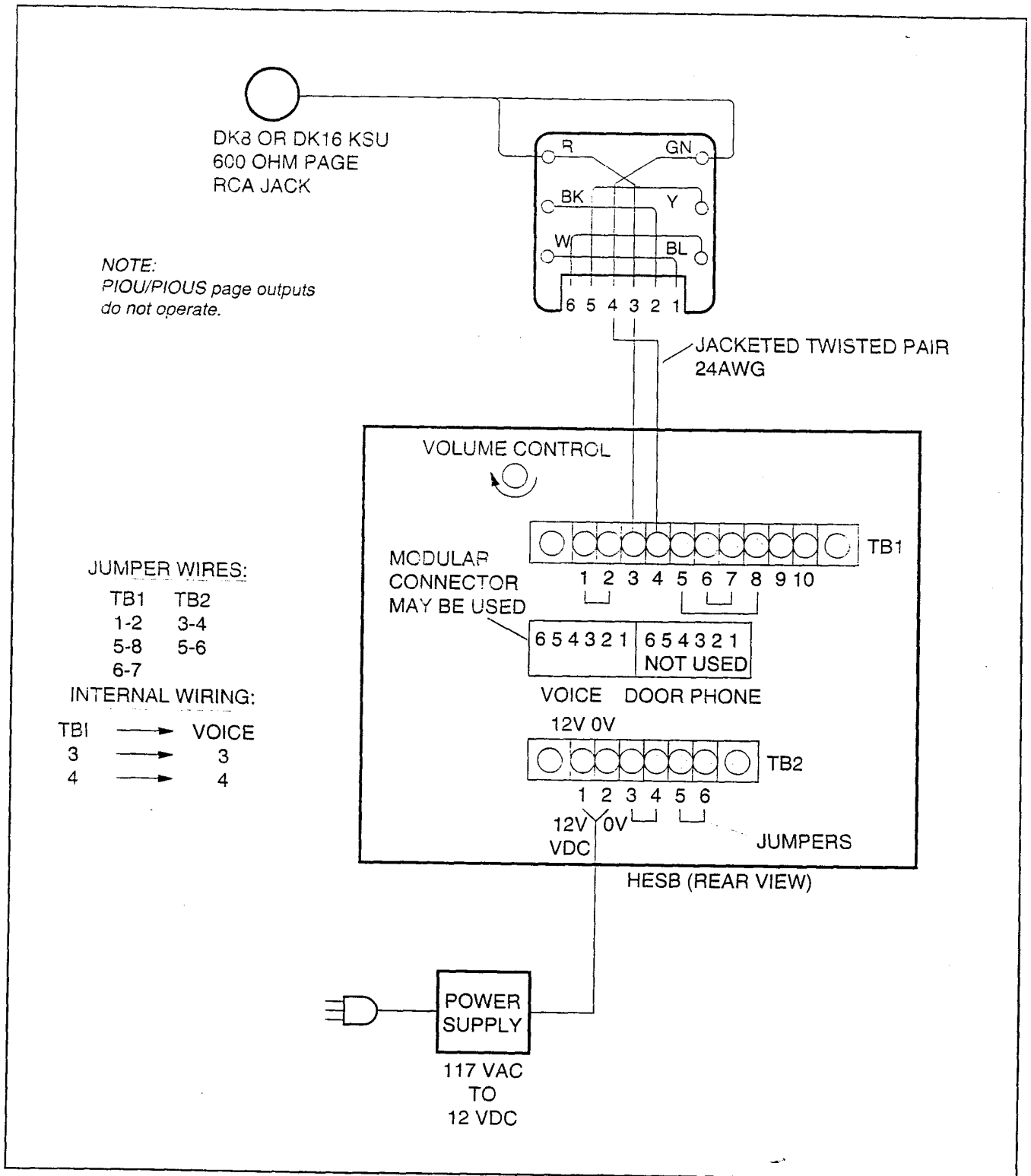
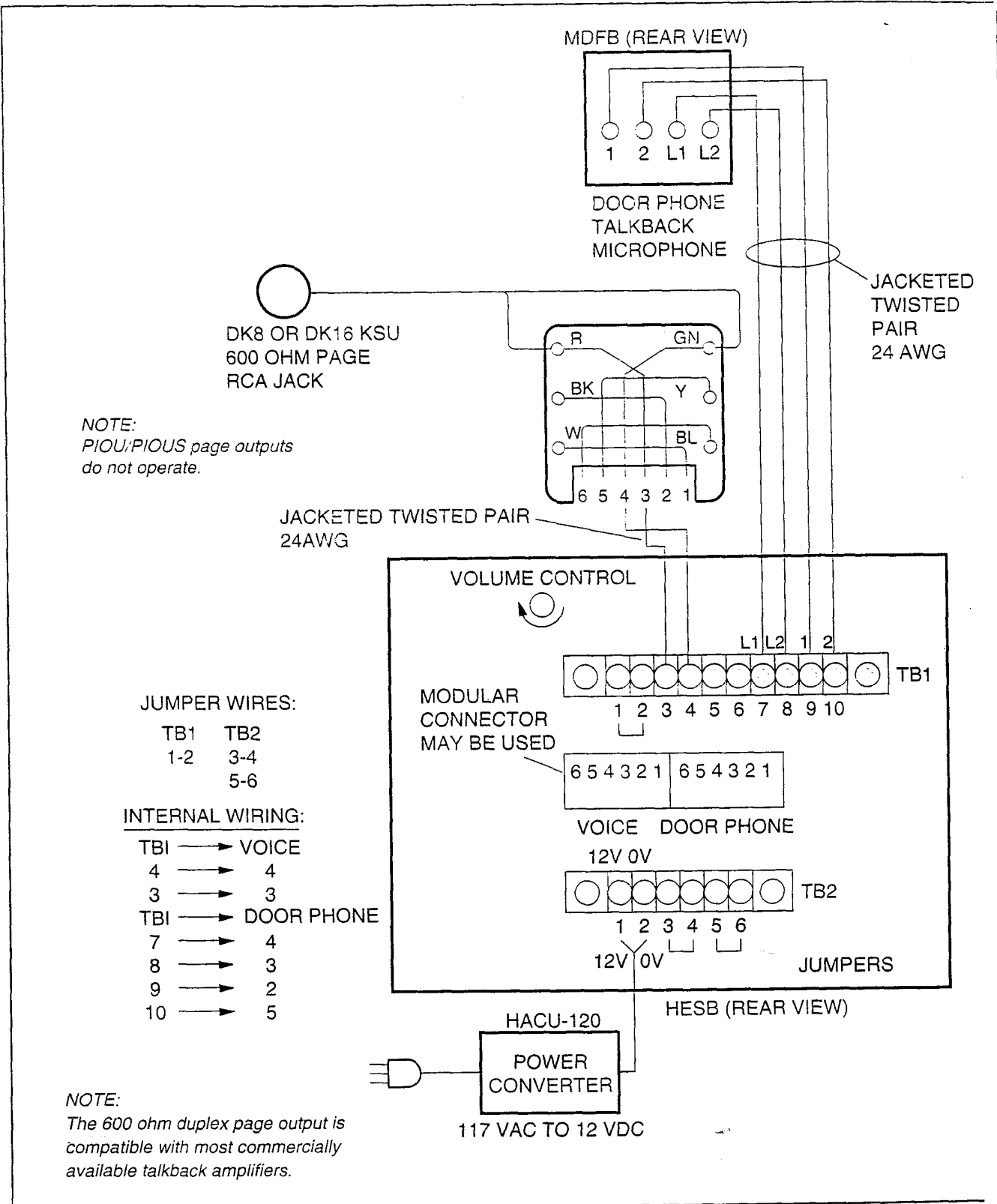


FIGURE 7-12  
 DK8 AND DK16 HESB/AMPLIFIED SPEAKER WIRING



**FIGURE 7-13**  
**DK8 AND DK16 HESB/TALKBACK AMPLIFIED SPEAKER WIRING**

- 2) Screw a 1.25-inch panhead wood screw into the mounting surface, use wall anchors if mounting to drywall surface.
- 3) Hang the HESB from the screw.

## 5 EXTERNAL PAGE OPTIONS

### 5.00 System Hardware Requirements

5.01 The STRATA DK systems offer a variety of external page options. Additionally, a BGM option is available with each external page option. DK systems support:

- DK8 and DK16 Paging with BGM (same amplifier)
- DK16 Zone paging with BGM (separate amplifiers)
- DK16 Zone paging with BGM (multiple amplifiers)
- See Paragraph 2 of this section for more Page/BGM options

### 5.10 External Page Option Installation

5.11 All voice paging connections are made via the 600 ohm Page RCA jack on the DK8 KSU or DK16 Base Unit. The PIOU and PIOUS voice and BGM (600 ohm and 3 watt) outputs are inoperable on the DK16 Expansion Unit.

5.12 **DK8 and DK16 Page with Separate External BGM (same amplifier).** In this configuration the MOH source or alternate BGM source provides BGM to digital/electronic telephones and a separate BGM source provides music to external speakers. Also, in this configuration Paging and external BGM are amplified by a common customer-supplied paging amplifier. When the external page access code is dialed, the external page control relay is activated, which applies a short to the amplifier mute control to mute the external BGM music. Install this option in accordance with the following steps (refer to Figure 7-15):

- 1) Connect the input no. 1 from the paging amplifier via an RJ11 jack to the 600 ohm RCA jack on the DK8 KSU or DK16 Base Unit.

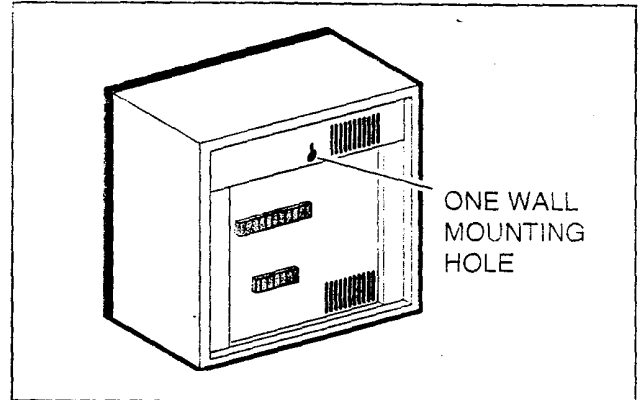


FIGURE 7-14  
HESB WALL MOUNTING

- 2) Connect the paging amplifier mute terminal via a MDF to pins 42 and 17 of the 25-pair amphenol connector from the DK8 KSU or DK16 Base Unit.
- 3) Connect the music source to the input no. 2 of the paging amplifier.
- 4) Connect the speaker to the paging amplifier output.

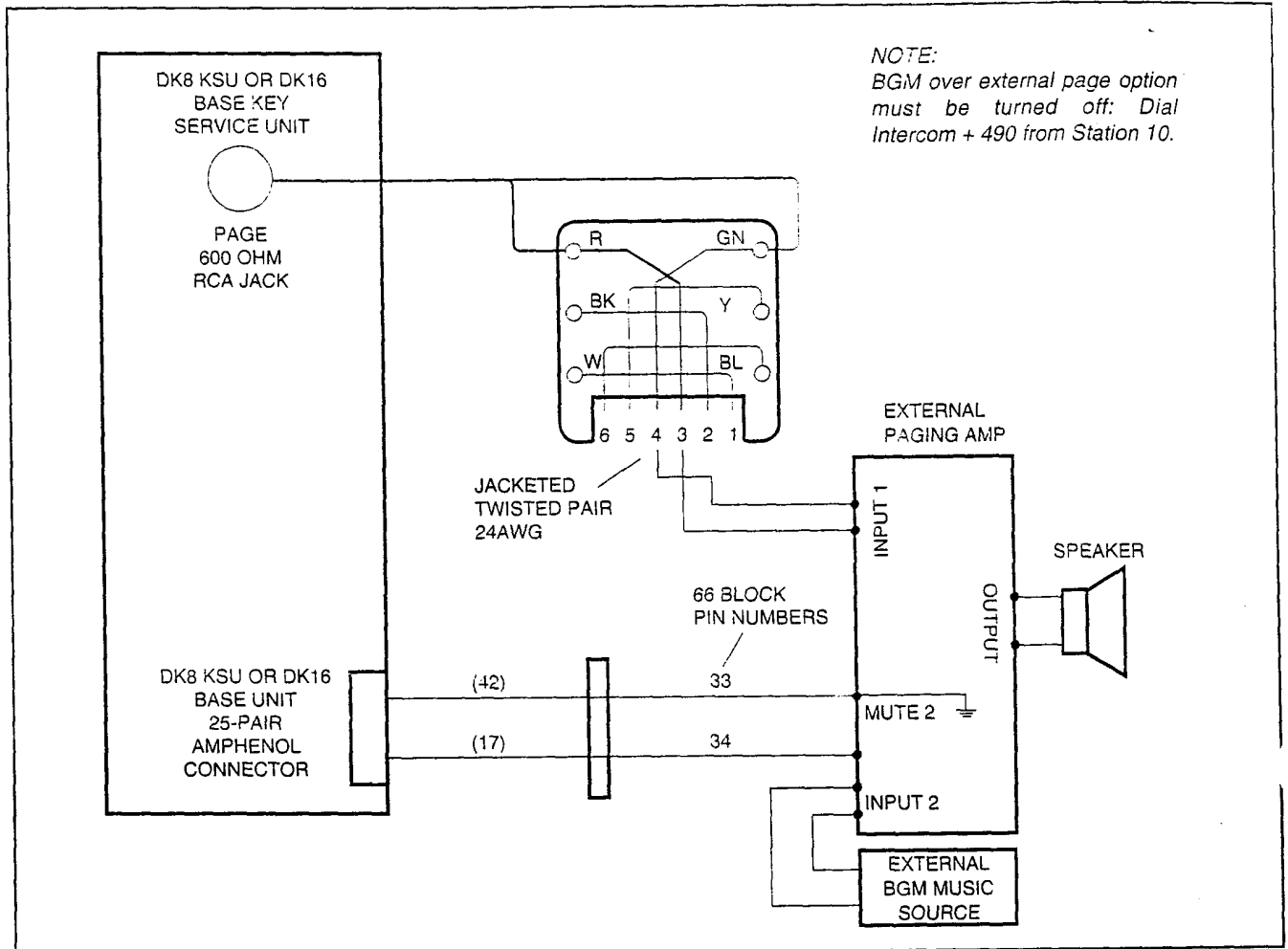
5.13 **DK16 Zone Page with BGM (separate amplifiers).** This configuration provides multiple-zone paging capability. The output of the paging amplifier is routed back to the PIOU, where it is switched to one of four sets of speakers by PIOU relays **K1** through **K4**. The relay selected is determined by the access code dialed by the station user. Default access codes are:

- K1/zone A = 35
- K2/zone B = 36
- K3/zone C = 37
- K4/zone D = 38
- All zones = 39

**NOTE:**

*Multi-zone page output rating is 30W/maximum at 300 ohms.*

5.14 An all zone page code (39) is also available as an option (see **Program 10-2**). When the all page code is dialed, all four relays are activated to permit simultaneous paging to all speaker zones and all digital and electronic telephone speakers. Install this option in accordance with the following steps (refer to Figure 7-16):



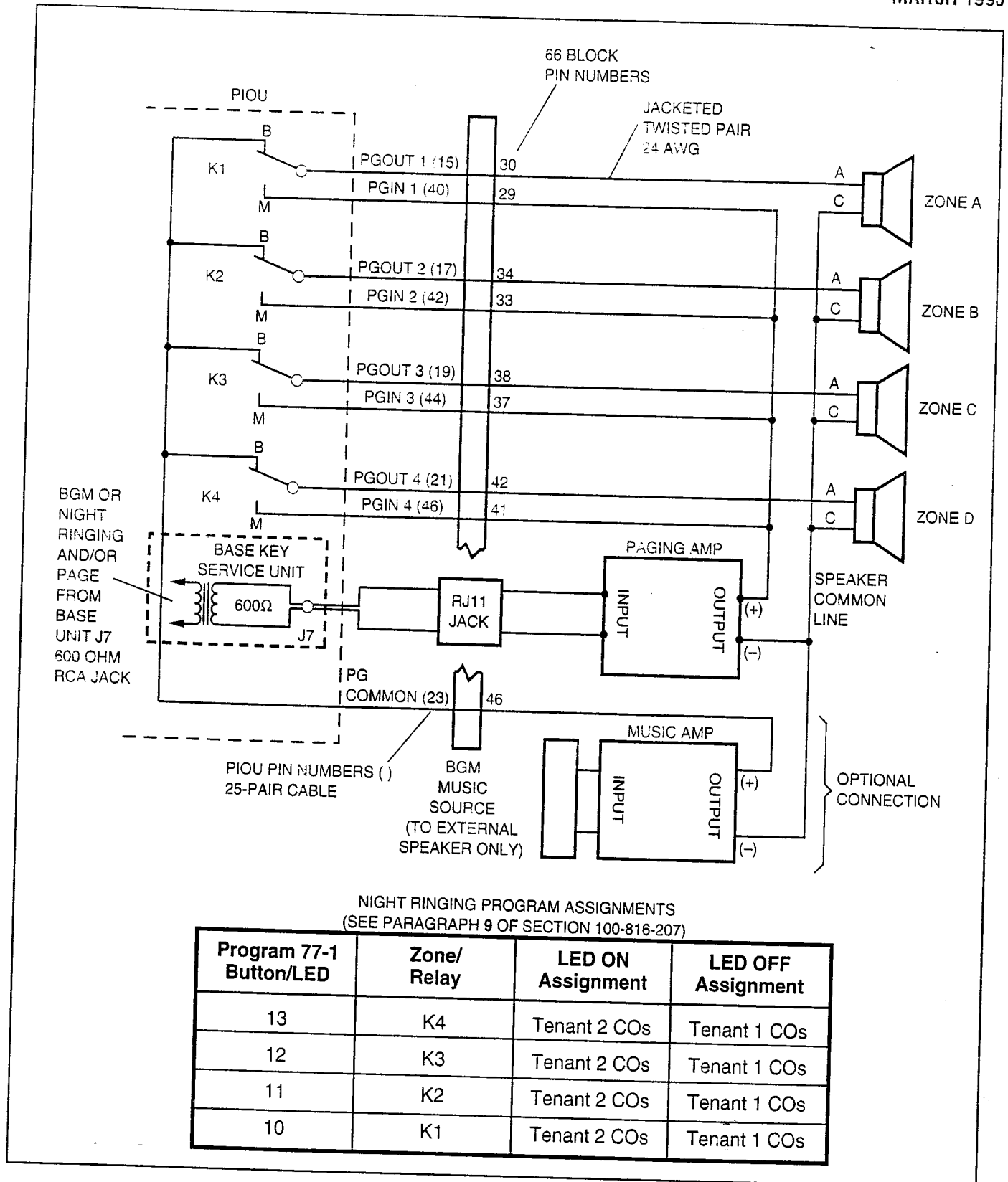
**FIGURE 7-15**  
**DK8 AND DK16 PAGE AND SEPARATE BGM USING SAME AMPLIFIER**

- 1) Connect the input from the paging amplifier via an RJ11 jack to the J7 600 ohm RCA Jack on the Base Unit. Or, direct connect J7 to Amp using a standard audio cable with RCA plugs.
- 2) Connect the BGM music source to the music amplifier input.
- 3) Connect the paging amplifier's (+) output to each PGIN of the PIOUS K1 ~ K4 relays and the amplifier's (-) output to each of the zone A ~ zone D speakers (C).
- 4) Connect the BGM music amplifier (+) output to terminal 23 (PG COMMON) of the PIOUS, and the (-) to the (-) output of the page amplifier.
- 5) Connect the PIOUS PGOUT pins to the zone A ~ zone D speakers (A).

**5.15 DK16 Zone Page with BGM (multiple amplifiers).** This configuration also provides multiple-zone paging capability, as in Paragraph 5.13. However, separate amplifiers are used for each zone. Install this option in accordance with the following steps (refer to Figure 7-17):

- 1) Connect the inputs from the paging amplifiers via an RJ11 jack to the J7 600 ohm Page RCA Jack on the Base unit. Or, direct connect J7 to Amp using a standard audio cable with RCA plugs.





NIGHT RINGING PROGRAM ASSIGNMENTS  
(SEE PARAGRAPH 9 OF SECTION 100-816-207)

Program 77-1 Button/LED	Zone/Relay	LED ON Assignment	LED OFF Assignment
13	K4	Tenant 2 COs	Tenant 1 COs
12	K3	Tenant 2 COs	Tenant 1 COs
11	K2	Tenant 2 COs	Tenant 1 COs
10	K1	Tenant 2 COs	Tenant 1 COs

FIGURE 7-16  
DK16 PIU ZONE, PAGE/BGM/NIGHT RING (SEPARATE AMPLIFIERS)

INSTALLATION-PERIPHERALS  
 SECTION 100-816-207  
 MARCH 1993

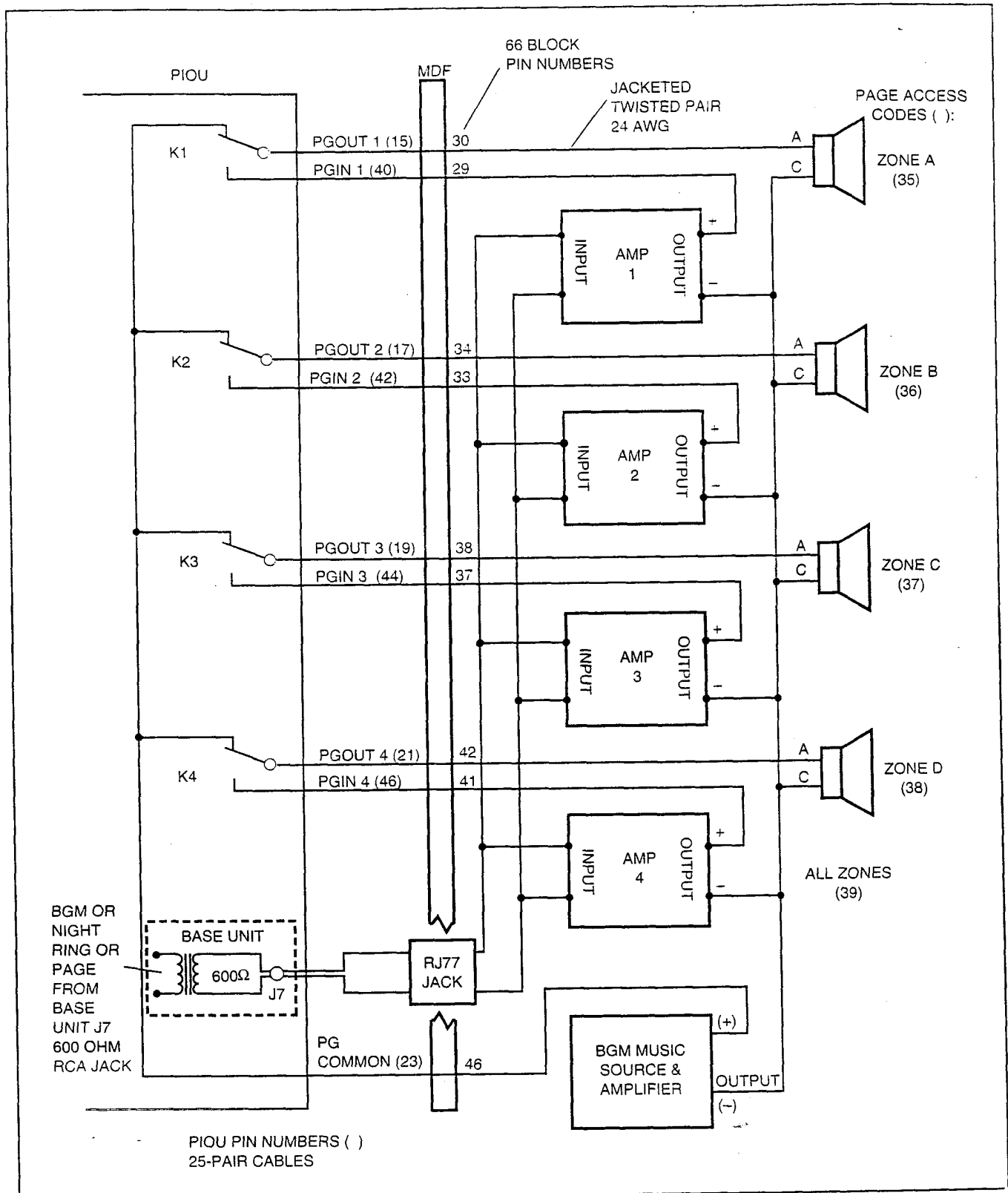


FIGURE 7-17  
 DK16 PAGING WITH MULTIPLE AMPLIFIERS

- 2) Connect the music source to the music amplifier input.
- 3) Connect the paging amplifier outputs to PIOUS (PGIN) relays K1 ~ K4 and zone A ~ zone D speakers (C).
- 4) Connect the music amplifier (+) output to terminal 23 (PG COMMON) of the PIOUS, and the (-) output to the "C" terminal of zone A ~ zone D speakers.
- 5) Connect zone A ~ zone D speakers "A" terminal to the "PGOUT" contact of the PIOUS relays K1 ~ K4 respectively.

**5.16 DK16 Night Ringing over All External Page Zones (PIOUS only).** To allow the night ringing signal to be sent over zone paging, install the paging amplifier in accordance with the following steps (refer to Figure 7-18). (Steps 2 ~ 6 are performed at the MDF.)

*IMPORTANT NOTE: To night ring over selected PAGE zone, see Paragraph 9 of this section.*

- 1) Connect the amplifier input via an RJ11 jack to the J7 600 ohm Page RCA jack on the Base unit. Or, direct connect J7 to Amp using a standard audio cable with RCA plugs.
- 2) Cross-connect the amplifier output A to the PGIN1 ~ PGIN4 connector from the PIOUS.
- 3) Cross-connect the amplifier output B to the zone A ~ zone D speaker common line.
- 4) Cross-connect the PIOUS PGOUT1 ~ PGOUT4 to zone A ~ zone D speakers (A).
- 5) Cross-connect the amplifier output A to pin 9 (NHR) of the PIOUS.
- 6) Cross-connect a jumper from pin 34 (NHT) to pin 23 (PG COMMON) from the PIOUS PCB.
- 7) In **Program 77-1**, set **LED 05 to OFF** and **06 to ON**. Set **LED 08 to ON** if door phones are to ring over external page when the system is in NIGHT mode.

- 8) In **Program 78**, enable the CO lines that are to ring via external page when the system is set in the NIGHT mode.
- 9) In **Program 39**, assign the **Night Transfer 1** or **Night Transfer 2** buttons to digital or electronic telephones per the System Record Sheets (see Note 2).
- 10) Press the **Night Transfer 1** or **Night Transfer 2** button on an electronic or digital telephone to set the system into the NIGHT mode. Test by calling into the system on a CO line assigned (**Program 78**) to night ring over external page.
  - When ringing sounds (see Note 2) over the page, press **Intercom 5 3 5** to answer.

**NOTES:**

1. All zones will ring with this option; night ringing to selected zones is not possible; see paragraph 9 for night ring over selected page zones.
2. The **Night Transfer 1** or **Night Transfer 2** buttons put CO lines in NIGHT ring mode per **Program 15**; NT1-TENANT 1/NT2-TENANT 2 CO line assignment.

**6 DK8 AND DK16 STATION MESSAGE  
DETAIL RECORDING (SMDR) PRINTER/  
CALL ACCOUNTING DEVICE OPTIONS**

**6.00** An SMDR printer or call accounting device may be connected to the system to provide a hard-copy record of station activity (incoming, outgoing, and transferred calls account code entries) on CO lines or a printout of the customer data base. Call record data is printed out at the completion of each call. Program SMDR with **Program 60**, and use **Program 97** to have the SMDR printer display the customer data base.

**6.01** SMDR will send out special names for the following types of calls:

- **MSS:** Prints on DISA calls to stations (see Note).
- **MODM:** Prints on calls to the IMDU remote maintenance modem (station 619).

INSTALLATION-PERIPHERALS  
 SECTION 100-816-207  
 MARCH 1993

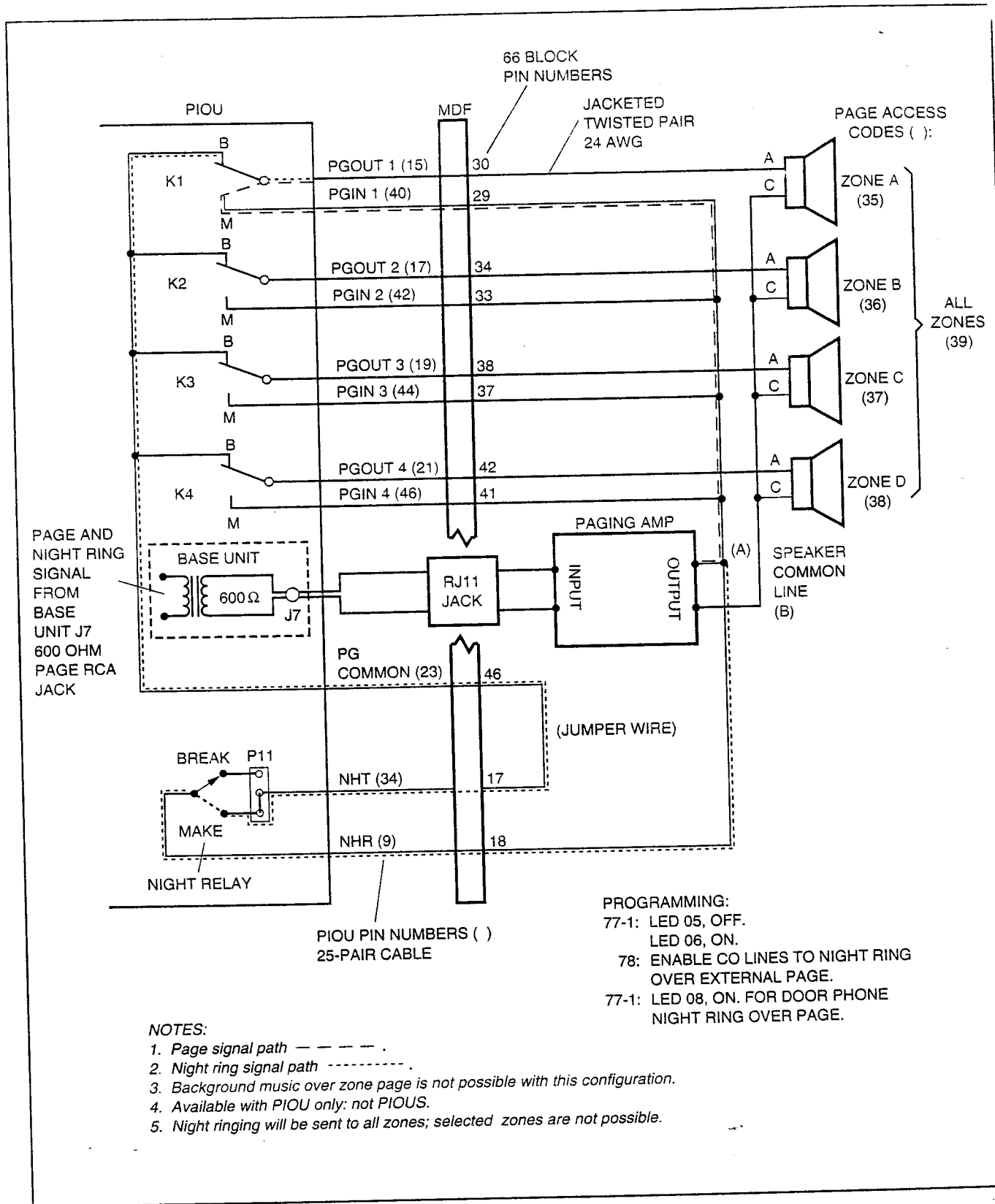


FIGURE 7-18  
 DK16 NIGHT RINGING OVER ALL EXTERNAL PAGE ZONES

- **DISA:** Prints on DISA calls to CO lines when calling through the system CO-to-CO.

**NOTE:**

*MSS will print only on DISA calls that are answered 10 seconds or 1 second (see Program 60-2) after the DK dial tone is sent to the calling party. If set for 10 seconds and the call is answered before 10 seconds, the call will register as a normal incoming call and the MSS/transfer portion of the call will not print out.*

**6.02** Figure 7-19 shows a sample SMDR printout and describes the contents of each column of the printout. The following examples show several call record samples and describe the sequence of events which occurred to generate the call records.

**NOTE:**

*SMDR printout "time of day" and day/month/year (DD/MM/YY) is the same as the system clock time/date. SMDR DD/MM/YY will print out each time 50 call records are generated.*

### SMDR PRINTOUT EXAMPLES

#### Direct Inward System Access (DISA) CO Lines

**NOTE:**

*DISA station calls print out as MSS.*

#### EXAMPLE 1—Ring, No Answer DISA Call

##### Call Sequence A

- Outside caller rings CO line 03 (CO line 03 is programmed as a DISA line).
- Line 03 returns intercom dial tone to caller after two ring cycles (5 ~ 6 seconds).
- Caller does nothing.
- After 32 seconds, call is disconnected.
- Printout **A** prints after disconnect at 4:59.

##### PRINTOUT A

```
03 MSS 04:59 00:00:32 00:06
```

#### EXAMPLE 2—DISA Internal Station Call

##### Call Sequence B

- Outside caller rings CO line 03 (CO line 03 is programmed as a DISA line).

- Line 03 returns intercom dial tone to caller after two ring cycles (5 ~ 6 seconds).
- Caller dials 13.
- After 48 seconds from start of call, station 13 answers.
- Printout **B** prints after station 13 answers the call at 4:32.

**NOTE:**

*If Program 60-2 is set for 10 seconds, MSS will not print if the call is answered within 10 seconds from when the caller receives dial tone.*

##### PRINTOUT B

```
03 MSS 04:32 00:00:48 00:05 13
```

#### EXAMPLE 3—DISA Outgoing CO Line Call

**NOTE:**

*DISA CO line calls print out as DISA.*

##### Call Sequence C

- Outside caller rings CO line 01 (line 01 is programmed as DISA).
- Line 01 returns intercom dial tone after two ring cycles (5 ~ 6 seconds).
- Caller dials 703 to access CO line 03 (outgoing).
- Caller dials the DISA security code and receives CO dial tone.
- Caller dials the telephone number and converses when the call is answered.
- Caller hangs up.
- The call releases, and Printout **C** prints after the call disconnects at 12:22.

**NOTES:**

1. *If the CO provides the auto release (AR) signal (see Program 15), the call disconnects when either party hangs up. A "\*" will print out following the CO line number if the call is disconnected by the AR signal.*
2. *If the auto release signal is not returned, the CO lines will remain seized until the DISA disconnect timer releases the call (approximately five minutes).*

##### PRINTOUT C

##### Auto Release Signal:

```
03*DISA 12:22 00:02;01 (outgoing)  
01 DISA 12:22 00:02;01 (incoming)
```

INSTALLATION-PERIPHERALS  
SECTION 100-816-207  
MARCH 1993

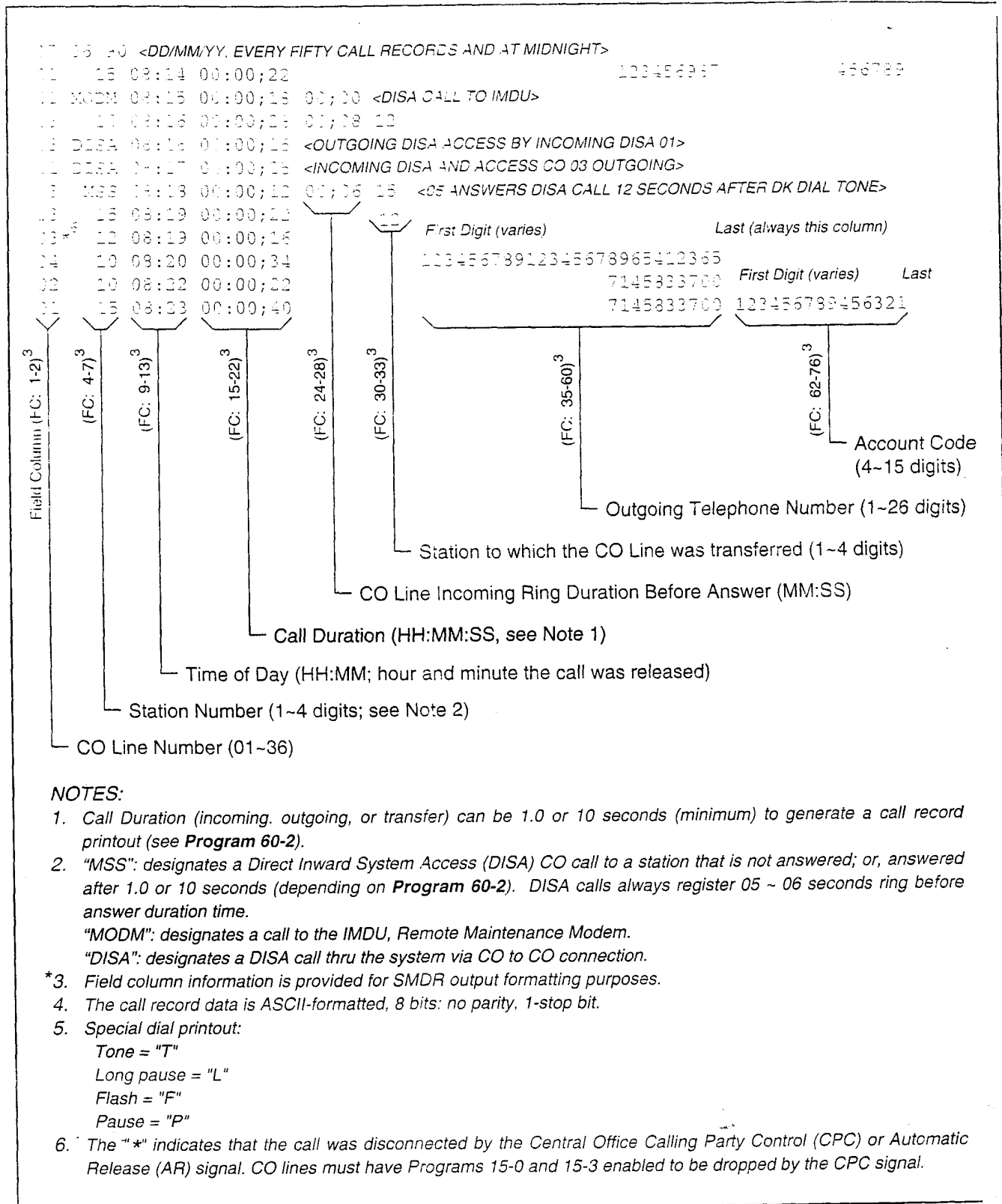


FIGURE 7-19  
DK8 AND DK16 SMDR PRINTOUT EXAMPLES

**Disconnect Timer:**

- 1 DISA 12:04 00:04;17 (Incoming)
- 3 DISA 12:04 00:04;57 (Outgoing)

**6.03 System Program Data Printout.** If a printer is connected to the SMDR port on the QSMU, PIOUS, or PIOUS, customer program information stored in the system RAM may be printed out for reference by using **Program 97** (see Paragraph 6.14).

**6.10 SMDR Hardware Requirements**

**6.11** The DK8 system must be equipped with a QSMU option PCB. QSMU **Program 10-3, LED 04** must be **OFF**. Install the QSMU PCB in accordance with Section 100-816-204 and wire the SMDR device to the QSMU (PPTC/modular cord) in accordance with Section 100-816-208. The DK16 system must be equipped with a PIOUS or PIOUS PCB in the Expansion Unit to support the SMDR printer/call accounting device option. Connection of the printer or call accounting device to the PIOUS or PIOUS PCB is accomplished with a 3-pair modular cord (7 feet maximum) and a PPTC connector adaptor (refer to Figure 7-20 for details). Call record data is ASCII-formatted, 8 bits, no parity, 1-stop bit.

**6.12** The DK8 KSU and DK16 PIOUS or PIOUS contains a call record buffer which stores call record data (for 20 calls on DK8 or 50 calls on DK16) when the printer or call accounting device is turned off, or when no device is connected to the SMDR port. No further call records are stored after the buffer is filled. When the printer or call accounting device is made operational, an "ERROR BUFFER OVERFLOW" message is printed to indicate that the buffer was full, and that some call information may have been lost.

**6.13 SMDR Programming Considerations**

**6.14** Selectable programming options for the SMDR printer or call accounting device are:

**Program 60**

- Item 2—Determines the length of time a call must be active before it will be registered by SMDR.

- Item 3—Selects the records of outgoing calls or outgoing and incoming calls to be printed.
- Item 4—Selects digit length of account code (4 to 15 digits).
- Item 5—Allows only long distance call records to be printed.

**Program 97**

- Allows system program data to be printed via the SMDR port (refer to Figure 7-21 for an example printout).

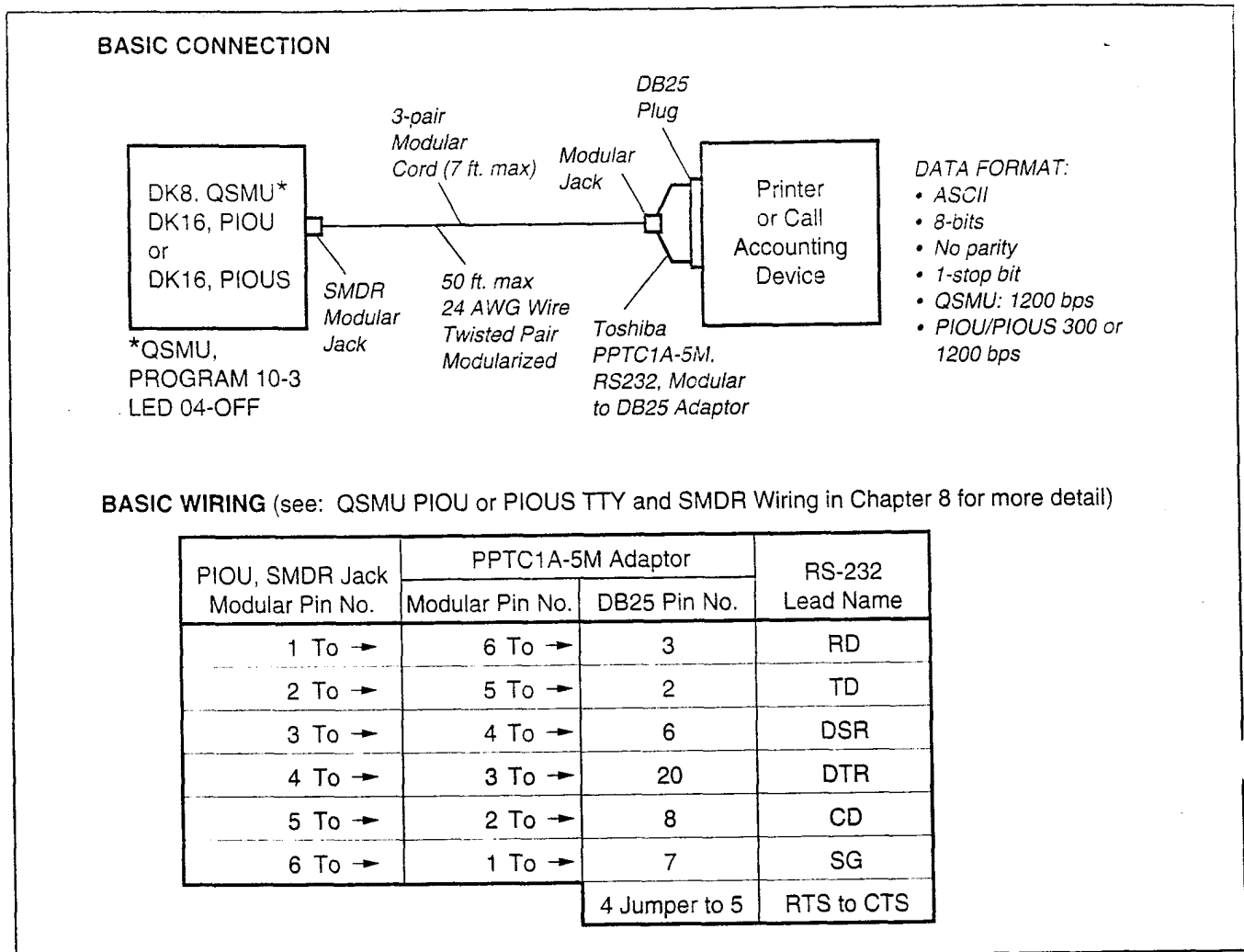
**NOTES:**

1. An SMDR printer must be connected to the SMDR port to use the printout option selected by **Program 97**.
2. Call record data is lost when program data is printed out using **Program 97**.

**6.20 SMDR Printer/Call Accounting Device Installation**

**6.21** Install the SMDR printer/call accounting device option in accordance with the following steps (refer to Figures 7-20, 8-26, and 8-24):

- 1) Connect the interface cable and the PPTC adaptor from the DK8 QSMU or DK16 PIOUS or PIOUS SMDR port to the SMDR printer or call accounting device DB25 connector.
- 2) Set the DK16 PIOUS or PIOUS **SW1** switch to the appropriate baud rate (300 or 1200 bps), as determined by the baud rate of the printer or call accounting device. For DK8, QSMU is always 1200 bps.
- 3) The DK8 QSMU **Program 10-3, LED 04** must be **OFF** for SMDR operation.
- 4) Set the printer or call accounting device to 8-bits/no parity/one stop bit.
- 5) Program (**Program 60**) the system for the required SMDR printer/call accounting device options (refer to Paragraph 6.13 and the Programming Procedures, Section 100-816-300).



**FIGURE 7-20**  
**DK8 AND DK16 PIOUS/PIOUS SMDR CABLE CONNECTIONS**

## 7 VOICE MAIL OPTIONS

### 7.00 System Hardware Requirements

**7.01** The STRATA DK8 and DK16 may be configured to support Toshiba VP voice mail messaging system or a customer-supplier voice mail system.

**7.02** The DK8 must be equipped with a QSTU, and the DK16 must be equipped with a KSTU, PSTU, or PESU to support a voice mail system. The DK8 QSTU is equipped with two standard telephone circuits; the DK16 KSTU is equipped with four standard telephone circuits, the PSTU with eight, and the PESU with two. A K4RCU subassembly

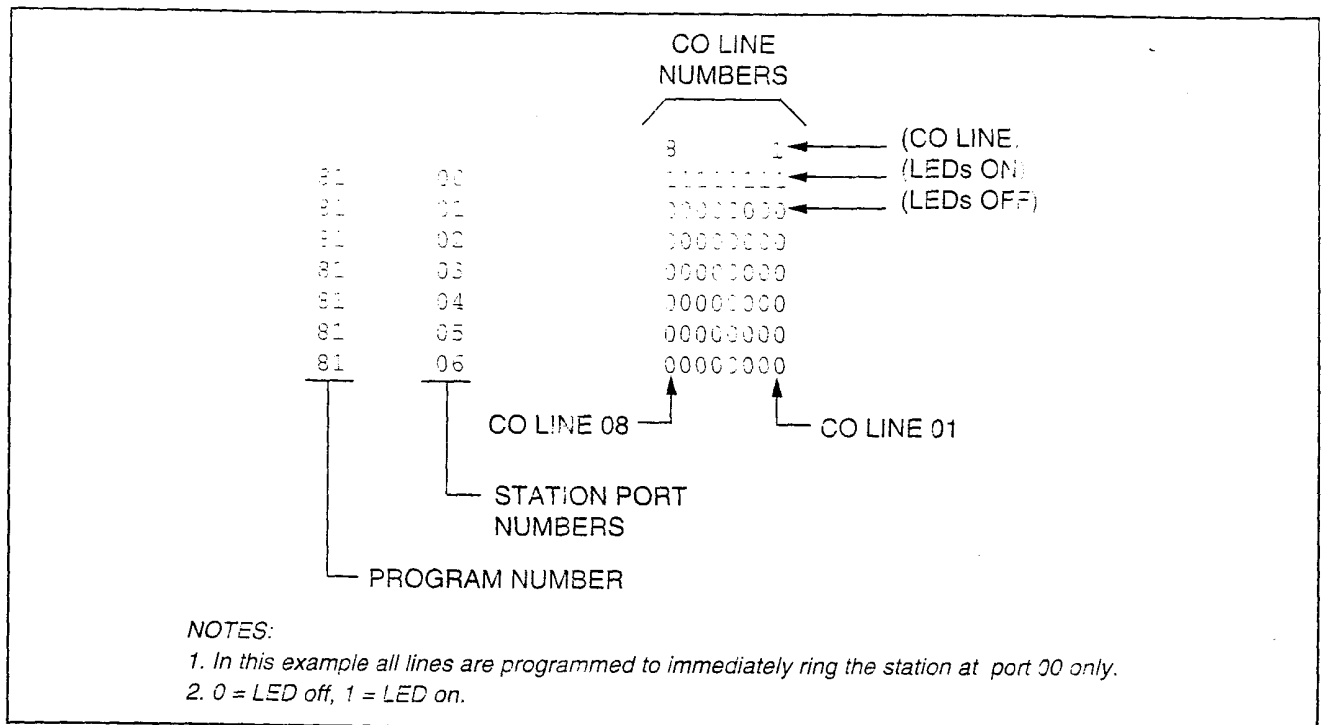
must be installed in the DK16 Base Unit, and a QRCU must be installed in the DK8 KSU. The voice mail system can be connected to any standard telephone circuit at the MDF block.

### 7.10 Toshiba VP Voice Messaging System

**7.11** The STRATA DK8 and DK16 is designed to support the full range of features offered by the Toshiba VP provides various call routing, message handling, and information management features, including:

- Automated Attendant
- Call Forward to Voice Mailbox
- Message Waiting Indication





**FIGURE 7-21**  
**PIU/PIOUS SMDR PORT (PROGRAM 97) DATA DUMP EXAMPLE**

- Voice Mail Control from digital and electronic telephone
- System Monitoring
- Feature Integration

**7.12** A block diagram of voice mail connections is shown in Figure 7-22. See Section **100-816-204** for QSTU and Section **100-816-205** for PSTU, KSTU, and PESU installation instructions.

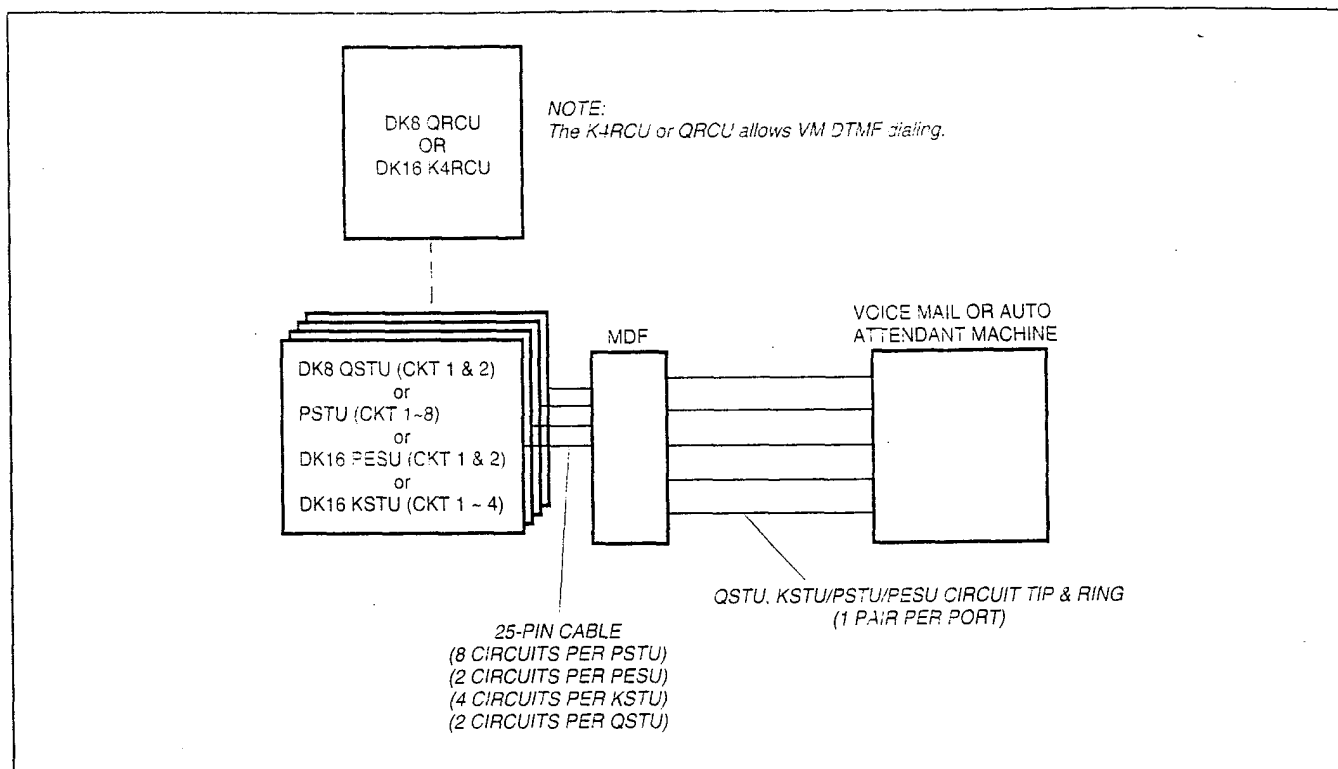
**7.13 STRATA DK8 and DK16/VP Programming Considerations.** Some features of STRATA DK8 and DK16 system programming are intended for Toshiba VP, and are not necessarily available for customer-supplied voice mail messaging systems. These programming features are:

- **Answer (A) Tone.** The STRATA DK8 and DK16 stations will send an answer tone to Toshiba VP when the station answers a Toshiba VP call.
- **Disconnect (D) Tone.** The STRATA DK8 and DK16 stations will send a disconnect tone to Toshiba VP when the station hangs up while connected to Toshiba VP. (D-Tone is also sent to

release the Toshiba VP auto attendant port when an outside CO line caller hangs-up and the Central Office provides a disconnect signal, per **Program 15-0** and **15-3**.)

**NOTE:**

1. Not all Central Offices provide the disconnect signal (calling party control) so this feature will not operate in all areas.
2. Both answer and disconnect tones provide more efficient Toshiba VP port use. Always enable these options. Both options are enabled by accessing **Program 31** and setting LED 15 to **ON** (LEDs 16 and 17 must also be **ON** to allow A and D tones), and by accessing **Program 15-0** and **15-3** and enabling CO lines with ARVM and AROH calls.
3. The AR signal of some Central Offices is not reliable and may occur at times during a CO line voice connection causing the call to disconnect during a conversation. If this occurs, **disable** AROH and ARVM calls on all CO lines (**Program 15-0** and **15-3**).



**FIGURE 7-22**  
**DK8 AND DK16 VOICE MAIL/AUTO ATTENDANT BLOCK DIAGRAM**

- **B Tone Signals.** Stations send a recall (B) tone to VP whenever Toshiba VP answers a transfer (camp-on) recall from a station that did not answer a Toshiba VP blind transfer. (The B tone notifies Toshiba VP that the call is a recall and not a new call, allowing Toshiba VP to respond with the appropriate greeting.) For this feature to operate, the QSTU, PSTU, KSTU, or PESU voice mail ports must have LEDs 19 and 20 turned **ON** in **Program 31**.

**7.14 Toshiba VP Installation.** Use the preceding information in concert with Paragraphs **7.23** and **7.24** to install Toshiba VP.

### 7.20 Customer-supplied Voice Mail Messaging Systems

**7.21 STRATA DK8 and DK16 systems** are designed to support a wide range of customer-supplied voice mail messaging systems. Depending on the voice mail system used, some of the features available with Toshiba VP (refer to Paragraph **7.10**)

may be available with the customer-supplied system.

### 7.22 DK8 and DK16 Voice Mail (QSTU, PSTU, KSTU, or PESU Port) Programming Considerations

**7.23** Voice mail (all types) QSTU, KSTU, PSTU, or PESU port programming is accomplished using **Programs 31** and **10-2** (refer to Programming Procedures, Section **100-816-300**, for details). Voice mail (VM) programming features are:

- **VM Groups**—This feature groups VM QSTU, KSTU, PSTU or PESU ports together so that message waiting set/cancel signals appear to originate from the lowest port in the VM group. All VM ports connected to a particular VM machine should be set in the *same* VM group (**Program 31**, LEDs 05 ~ 08).
- **Message Waiting Set/Cancel**—If the VM machine has the ability to dial a code, plus the appropriate station numbers to set or cancel the message waiting LEDs on electronic telephones,

program the VM machine to dial the following sequences (In **Program 10-2**, turn LED 04 ON):

- 1) To set a MW LED, the VM machine must dial **6 3** + station number.
- 2) To cancel a MW LED, the VM machine must dial **6 4** + station number.

*NOTE:*

*Only dial codes 63 and 64 are set in the VM device configuration; the VM device will dial the station number automatically to set/cancel the Message Waiting indication LED.*

- **No Conference VM**—Prevents undesired CO line three-party connections during VM call transfers. All VM ports should be set for no conference (**Program 31**, LED 09).
- **Privacy Override Deny**—Prevents stations from overriding (breaking in) in-progress VM calls (**Program 31**, LED 18).
- **End-to-End Signaling**—Allows VM port DTMF operation. All VM ports should be set for end-to-end signaling (**Program 31**, LED 17).

*NOTE:*

*The DK8 QRCU or DK16 K4RCU must be installed to allow End-to-End Signaling.*

- **VM to VM Call Blocking**—Prevents VM auto attendant calls from forwarding back to VM auto attendant during supervised transfers (**Program 31**, LED 04 ON). This will prevent the problem of auto attendant to auto attendant looping connections.
- **Receive Auto Call Forward ID Codes**—Provides auto digits from call forwarded stations to direct callers to stations' mailboxes. All VM ports should be set to receive auto ID code (**Program 31**, LED 16).
- "A" and "D" tones; see Paragraph 7.13.

**7.24 Voice Mail Program Checklist.** The following items should be verified before programming voice mail:

- 1) Set Toshiba VP Maintenance Menu system parameters to "D" = STRATA DK8 and DK16

(see Toshiba VP *Installation and Maintenance Manual* for other parameter settings).

- 2) STRATA DK8 and DK16 programs:
  - **Program 92:** Initialization clears voice mail auto dial codes.
  - **Program 03:** Verify that the KRCU is programmed in the Base Unit to allow the VM/AA to send DTMF tones (does not apply to DK8).
  - **Program 04:** Assigns station numbers to VM/AA ports (initialized numbers recommended).
  - **Program 05:** First digit of special codes 63 and 64 (initialized numbers recommended).
  - **Program 10-1:** Set the system for voice first, and program the VM/AA device to dial the suffix as "1" after station numbers.
  - **Program 10-2:** Set LED 04 ON for set/cancel operation and 06 ON for the VM to detect 30 msec. tones.
  - **Program 13:** If the VM/AA device is the message center, set the lowest VM port as the message center.
  - **Program 31:** Turn LEDs 05, 09, and 15 ~ 20 ON for the QSTU, KSTU, PESU, or PSTU ports that are connected to the Toshiba VP VM/AA ports. Do not set these options for standard telephone, digital telephone, or electronic telephone station ports. LED 04 should be off if the auto attendant only "BLIND" transfers; if the AA does "Supervise" or "Screened" transfers, set LED 04 ON for auto attendant ports.

*NOTE:*

*A, D, and B tones should be enabled only for VM/AA devices that respond to these tones.*

- **Program 33:** Set the QSTU, KSTU, PESU and PSTU ports that are connected to the VM/AA ports to a hunting sequence, starting with the lowest port hunting to the next highest port, etc. The last hunt should be to an attendant.
- **Program 35:** LEDs 01 and 02 must be ON for stations to receive the message indication (Msg LED flashing) from a VM device.

INSTALLATION-PERIPHERALS  
SECTION 100-816-207  
MARCH 1993

- **Program 35:** LED 20 should be ON to assign auto attendant ports the "Busy Station Transfer" option. With this option the auto attendant will receive ring backtone when calling stations designated with "Busy Station Ringing" (Program 35, LED 19 ON). This allows the auto attendant to transfer calls to busy stations. Set LED 19 ON for answer position stations.
- **Program 36:** Set fixed call forward to VM/AA port per customer requirements.
- **Program 37:** Set the timer for the VM/AA ports to 22 seconds minimum to allow call forward no answer to work on VM transferred calls.
- **Program 39:** Set the Message Waiting Indication, Fixed Call Forward, Redial, and Speed Dial Select buttons on the digital and electronic telephones that will be used to communicate with the VM/AA device.

**NOTE:**

*Message Waiting (Msg) and Redial buttons are fixed buttons on digital telephones and it is not necessary to assign them in Program 39. Speed Dial is initialized as Button 20 on Digital telephones.*

- **Programs 81 ~ 89:** Verify that the ringing assignments to the VM/AA devices are set per customer requirements.
- **Programs 16, 40, 41, 45 ~ 48 and 50 ~ 56:** Verify that outgoing CO line access is allowed on VM ports to allow the VM/AA beeper notification feature to operate.

**7.25 Voice Mail System Installation.** Install the voice mail messaging system in accordance with the following steps (See Figure 7-22):

- 1) Ensure that the QSTU, KSTU, PSTU, or PESU PCB is installed in the system per Section **100-816-204** (DK8) or Section **100-816-205** (DK16).
- 2) Connect the voice mail messaging system to the selected QSTU, KSTU, PSTU, or PESU

standard telephone ports (refer to Wiring Diagrams, Section **100-816-208**, for QSTU, PSTU, KSTU, and PESU wiring/interconnecting details).

- 3) Program the system for the required voice mail messaging features (refer to Paragraphs **7.13** and **7.22**).
- 4) Ensure that the DK8 QRCU or DK16 K4RCU is installed, and (for DK16) verify that the CTU code in Program 03 is for KRCU-4 operation as required (this is not required for DK8 QRCU).
- 5) Perform additional voice mail messaging system programming as applicable (refer to customer-supplied installation/programming manuals).

**NOTE:**

*Some voice mail devices may ring trip when called; in this case, set the ring voltage jumper to L (low position) on the QSTU, KSTU, PESU, or PSTU2 PCB connected to the voice mail device.*

## 8 DK16 ALARM SENSOR INSTALLATION

**8.00** The PIOU or PIOUS PCB provides a circuit that can be set to detect a relay open or closed condition from a facility alarm system. When the sensor is activated, all electronic and digital telephones will sound an alarm signal. The electronic/digital telephone alarm signal can be reset by any electronic or digital telephone with an alarm reset button (see Program 39).

**8.01 Alarm Sensor Options.** Jumper plug P12 on the PIOU is used to set the alarm sensor to detect an open or closed condition from the facility alarm system. Set P12 as follows (refer to Figure 7-23):

- To detect a closed condition, set P12 to the N.O. position.
- To detect an open condition, set P12 to the N.C. position.

8.02 Jumper W3 on the PIOUS is used to set the alarm sensor to detect an open or closed condition from the facility alarm system. Solder the W3 jumper wire as follows (refer to Figure 7-23):

- To detect a closed condition, solder W3 to the normal open position.
- To detect an open condition, solder W3 to the normal closed position.

8.03 Alarm Sensor Wiring. Refer to Figure 7-23, and connect the facility alarm system relay contacts to the PIOU/PIOUS PCB.

## 9 DK16 NIGHT RINGING OVER EXTERNAL ZONE PAGE

9.00 In systems shared by two tenants, each tenant's CO lines can be assigned to night ring separate PIOU external page zones (Figure 7-16). This feature can also be used in one-tenant systems.

9.01 With shared systems, for example, tenant 1's night ringing CO lines could be programmed to ring PIOU external page zones 1 and 2, while tenant 2's lines could be programmed to ring zones 3 and 4. In non-shared systems, night ringing CO lines can

be assigned to ring all of the zones or just selected zones.

9.02 The following programs must be used to assign CO lines to ring selected PIOU page zones:

- **Program 78-1:** Assigns CO lines, tenant 1 and tenant 2, that will night ring over PIOU external page zones.
- **Program 15-5:** Assigns CO lines to tenant 1 or tenant 2. Lines are initialized as tenant 1.
- **Program 77-1 (LEDs 10 ~ 13):** Assigns tenant 1 and tenant 2 CO lines to night ring specific PIOU external page zones. LED 06 must also be ON in Program 77-1.
- **Program 39:** Assigns appropriate **Night Transfer** or **Night Transfer 1** (tenant 1), and **NT2** (tenant 2) buttons to electronic and digital telephones.

### NOTES:

1. See Paragraph 5 and Figure 7-16 and 7-17 for PIOU zone paging installation instructions.
2. Any station can pick up CO lines that night ring over external page zones by dialing **Intercom 5 9**.

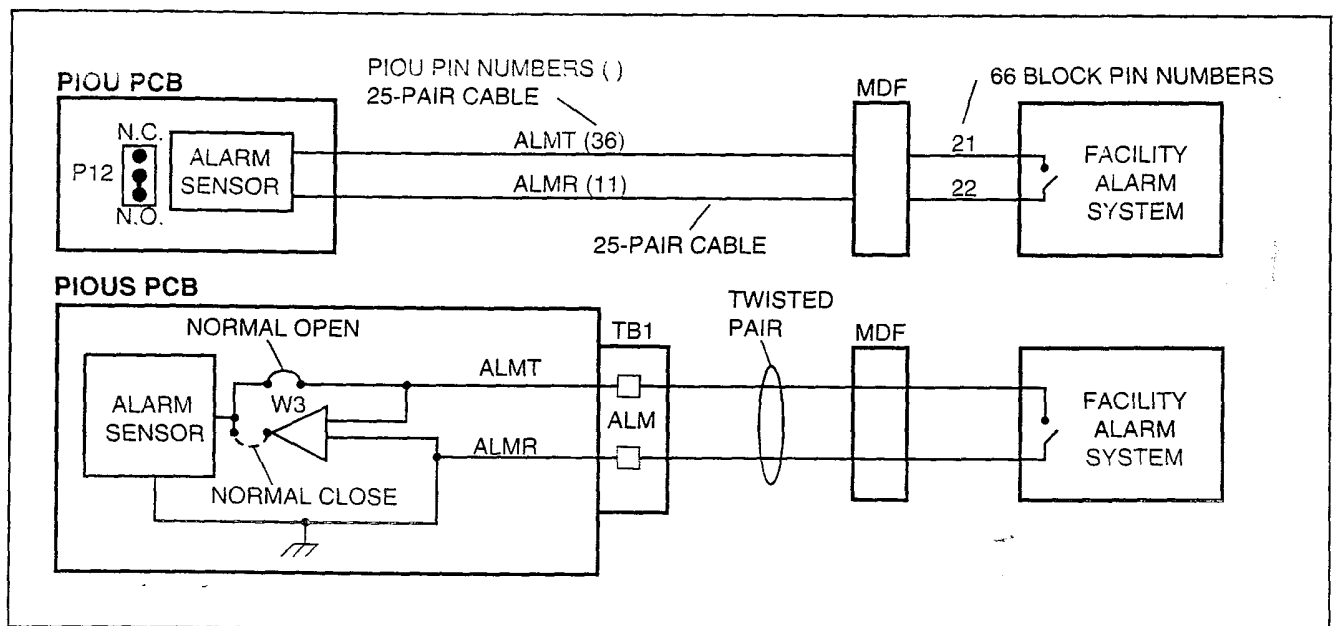


FIGURE 7-23  
DK16 ALARM SENSOR BLOCK DIAGRAM (PIOU/PIOUS)

## 10 DATA INTERFACE UNIT INSTALLATION

### 10.00 General

**10.01** STRATA DK8 and DK16 support two types of Data Interface Units (DIUs) that enable digital telephone users to simultaneously transmit and receive data on the same digital station port and wire pair while communicating on a voice call. One unit, called the integrated DIU (PDIU-DI/PDIU-DI2), becomes part of the digital telephone, replacing the telephone's base; the other unit, is a small self-contained unit called the stand-alone DIU (PDIU-DS). Each DIU is powered by the digital port it is connected (see Table 8-D for wiring requirements).

#### NOTES:

1. "Digital Ports" includes the DK8 KSU, DK16 Base Unit, PDKU and KODU digital station ports. This applies wherever the term "Digital Ports" is used in the text and figures in this chapter.
2. 2000-series digital telephones require PDIU-DI2 and 1000-series telephones require PDIU-DI.

**10.02** Both DIUs can be connected to standard Electronic Industries Association (EIA) RS-232 asynchronous serial data devices. EIA devices are divided into two categories: data communication equipment (DCE) and data terminal equipment (DTE). Common DCE devices are modems and some printers; common DTE devices are personal computers, ASCII terminals, and some printers. The PDIU-DI operates like a DCE and connects directly to DTE devices using standard RS-232 cables. Depending on how its internal jumper plugs are configured, the PDIU-DS can either operate like a DTE and connect to DCE devices; or operate like a DCE device and connect to a DTE device. In most applications, DTE and DCE devices exchange data between each other via the standard RS-232 cable connection.

**10.03** DIUs can function with DCE and DTE devices at data speeds of up to 19.2 kbps. However, keyboard dialing using AT commands (from a PC or terminal connected to a DIU) is limited to 9600

bps. A speed of 19.2 kbps can be achieved when dialing from a PDIU-DI-equipped digital telephone dialpad, but many PC software programs do not yet handle 19.2 kbps in an error-free manner. Also for a 19.2 Kbps operation the computer or terminal's "COM" port must be specified to function at 19.2 Kbps. Some computer "COM" ports, like those used in older IBM XT type computers, will not operate at 19.2 without errors. DIU data transmission speed is set by the first AT command that the DIU receives once it is in the command state; if manual dialing or receiving calls in the auto answer (default) mode, the transmission speed is transparent.

#### **IMPORTANT NOTE!**

*To use the PDIU-DI or PDIU-DS with AT commands, communications software or a PC program that performs terminal emulation must be used. AT commands cannot be issued from the computer's operating system prompt.*

### 10.10 Common DIU Connections

**10.11** The block diagram in Figure 7-24 illustrates common DIU connections. In this example, PDIU-DIs are connected to personal computers (PC1 and PC2), and PDIU-DSs are connected to a serial printer and modems. The personal computer users can transfer files internally, print files on the same printer, and access the modem pool to send/receive data to/from an external personal computer or dial up data service.

**10.12** To access these devices, a data call connection must be established between the DIUs. This is accomplished by dialing the destination DIU from a digital telephone dialpad or from a PC keyboard using standard AT dial commands. PDIU-DIs share the same intercom numbers/ports with the digital telephone to which they are connected, while PDIU-DSs have their own. The Intercom and Data Call LEDs on the digital telephone tell the system whether a voice or data call is being made: the Intercom LED, voice calls; and the Data Call LED initiates data calls. When dialing from a keyboard with AT commands **ATD** is typed for voice calls, and **ATDD** for data calls.

10.13 Installation instructions for these devices are provided in Paragraphs 10.40 thru 10.70. Call paths and scenarios for five types of data test calls are provided in Paragraphs 10.82 ~ 10.86. Step-by-step data calling procedures are provided in the *Data Interface User Guide* in the *Installation & Maintenance Manual, Operating Procedures*.

### 10.20 EIA Interface Leads (Signals)

10.21 Both DIUs operate with nine standard EIA RS-232 interface leads (signals) on which signaling data is transmitted and received. DIUs connect to serial data devices with standard RS-232 cables, available from telephone supply stores (see Figures 7-25 ~ 7-30). The PDIU-DI/PDIU-DS requires nine signals for some applications, but can function with eight using modular cords and connectors with RJ45/DB25 adapters for other applications. If uncertain which signals are necessary for an application, all nine should be connected.

#### IMPORTANT NOTES!

1. *The PDIU-DI is always a DCE device; the PDIU-DS may be a DTE or DCE, depending on how its internal jumpers (1 ~ 9) are configured.*
  2. *In the descriptions below, when a signal is ON, its potential is about seven volts positive relative to signal ground (pin 7); when a signal is OFF, it is about 7 volts negative relative to the signal ground (pin 7).*
- **Frame Ground (FG, Pin 1):** The FG signal (EIA circuit AA) is a protective or safety ground which is bonded to the PDIU-DI/PDIU-DS PCB. If required by local codes, the FG should be connected to external ground.
  - **Signal Ground (SG, Pin 7):** The SG signal (EIA circuit AB) establishes the common ground reference for all other PDIU and data device signals and must be wired for all applications.
  - **Transmit Data (TD, Pin 2):** DTE devices transmit and DCE devices receive data on the TD lead (EIA circuit BA). Before the DTE device can transmit the TD signal, the RTS, CTS, DSR, and DTR signals (all discussed below) must be ON. The TD signal is OFF in the idle state.
  - **Receive Data (RD, Pin 3):** The DCE device transmits data to the DTE device on the RD lead (EIA circuit BB); the DTE receives data on the RD.
  - **Request to Send (RTS, Pin 4):** Some DTE devices send an RTS signal (EIA circuit CA) to the DCE device when they are ready to transmit data on the TD lead. If the DTE device does not generate the RTS signal, the DIU DIP switch **SW1-4** should be set ON to inform the DIU. Sometimes, the DTE/DCE device may use RTS/CTS for Ready/Busy type flow control, in these cases DIP switch **SW1-4** should be OFF (see Figure 7-32 for DIP switch information).
  - **Clear to Send (CTS, Pin 5):** The DCE device sends the CTS signal (EIA circuit CB) which indicates that it is prepared to transmit data to the line side. The DCE device sends this signal only when it receives the RTS signal from the DTE device. Sometimes, the DTE/DCE device may use RTS/CTS for Ready/Busy type flow control; in these cases, dip switch **SW1-4** should be OFF (see Figure 7-32 for DIP switch information).
  - **Data Set Ready (DSR, Pin 6):** When connected to the communication channel and prepared to exchange control characters to initiate data transmission, the DCE device sends the DSR signal (EIA circuit CC) to the DTE device. If the PDIU DIP switch **SW1-2** is set ON, DSR will be ON continuously; if the switch is set OFF, DSR follows DTR (if DSR is ON, DTR is ON, etc.) **SW1-2** should be OFF in most cases (see Figure 7-32 for DIP switch information).
  - **Data Carrier Detect (DCD, Pin 8):** The DCE device sends the DCD signal (DCD, Pin 8) when receiving the carrier signal on the line side. Before transmitting or receiving data, most DTE devices require that the DCD be ON. If the carrier signal is removed by the remote end or lost due to a fault condition on the line, the DCE notifies the DTE device by an OFF condition with the DCD signal; PDIU DIP switch **SW1-2** is set ON to set the DCD ON continuously; if set OFF, the DCD signal will only be ON when connection between two DIUs is established and OFF when a connection is not established. **SW1-2** is set OFF when the DTE/DCE uses the DTR/DSR signals for Ready/Busy flow control (see Figure 7-32 for DIP switch information).

- **Data Terminal Ready (DTR, Pin 20):** The DTE device sends the DTR signal (EIA circuit CD) to the DCE device, prompting the DCE device to open the communication line. The line is closed and the call disconnected when the DTE device quits sending the DTR signal. DTR may be sent any time to indicate that the DTE is ready to transmit or receive data. DIP switch **SW1-2** should be set OFF in most cases (see Figure 7-32 for DIP switch information).
- **Ring Indicator (RI, Pin 22):** The RI signal (EIA circuit CE) is sent by the DCE device to the DTE device. Whenever the DCE device receives a ringing signal on the line side, it turns the RI signal ON. If DIU DIP switch **SW1-3** is set ON, the RI signal will be on continuously if ringing; if the switch is set OFF, the RI signal will be one second ON/three seconds OFF when the DIU detects ringing signal.

### 10.30 DIP Switch Options

**10.31** The PDIU-DI and the PDIU-DS each have a four-control DIP switch which can be configured for signaling options. The switch is located on the bottom of the PDIU-DI, and on the back panel of the PDIU-DS (see Figure 7-32).

- **SW1-1:** Normally this switch is set ON to disconnect devices from DIUs automatically. The connection is maintained if data is exchanged between the device and the DIU within eight to nine second intervals. If **SW1-1** is OFF on the called and calling DIU, data calls will remain connected until released manually.
- **SW1-2:** This switch is placed in the ON position when the PDIU-DI (or PDIU-DS configured like a DCE) must hold DCD and DSR ON continuously. If **SW1-2** is OFF, DSR follows DTR and DCD will be ON only when the DIU is connected on a data call to another DIU. **SW1-2** should be OFF on a DIU when it is connected to a personal computer that uses a communications software program to establish data calls with AT commands; and whenever PDIU-DS is connected to a modem.
- **SW1-3:** The PDIU-DI (or PDIU-DS configured as a DCE) sends the Ring Indicate (RI) signal to the computer to tell the computer (DTE) that the PDIU is receiving an incoming call. **SW1-3** should be ON for the DIU to send RI steady, and OFF to send at

one second ON/three seconds OFF intervals.

- **SW1-4:** This switch is placed in the ON position if the computer does not output the RTS signal or when connected to a modem that tracks the DCD signal (modem set with AT&C1). Sometimes, the DTE device may use RTS/CTS for Ready/Busy flow control, in these cases **SW1-4** should be OFF. In this case the DCD signal of the calling DTE is used as the RTS lead of the called DTE and the DCD signal of the called DTE is used as the RTS signal of the other DTE. In this case a signal which stops the DTE from transmitting data (usually the CTS lead) should be cross-connected to the DIU's DCD signal. Consult the DTE device or application software documentation to determine which type of flow control is required. If the DIU-DS is connected to a modem that tracks carrier detect (AT&C1) **SW1-4** should be ON.

### 10.40 PDIU-DI to Personal Computer (PC) Installation

**10.41** The PDIU-DI always functions as a DCE device; it transmits data on the Receive Data lead (RD) and receives data on the Transmit Data lead (TD). Most personal computers function as a DTE device; PCs transmit data on the TD lead and receive data on the RD lead. Follow the steps below to install the PDIU-DI to a DTE, PC:

#### NOTES:

1. Use the steps below when installing an ASCII terminal, personal computer, or any other DTE device to a PDIU-DI.
  2. The PDIU-DI can connect to a DCE computer or any other DCE-type device using a specially configured RS-232 cable or adapter; but this application is rarely required.
  3. Change the PDIU-DI escape sequence per the guidelines in paragraph 10.63.
- 1) Install the digital telephone that is to be equipped with PDIU-DI per the instructions in Section 100-816-206 and the drawing in Section 100-816-208.
  - 2) Install the PDIU-DI under the digital telephone per the instructions in Section 100-816-206.



**NOTE:**

The PDIU-DI always operates as a DCE device; therefore, unlike the PDIU-DS, it has no internal jumpers.

- 3) Connect the appropriate RS-232 cable between the PDIU-DI's DB-25 female connector and the PC's appropriate asynchronous serial communications port connector (COM port).

**IMPORTANT NOTE!**

*Check the PC manufacturer's serial communication port interface documentation for correct RS-232 pin requirements; requirements vary with each manufacturer. The number of EIA RS-232 signals required (8, 9, or 10 wires) depends on the application. When EIA signal requirements are not known, connect the 10 EIA signals listed in Paragraph 10.20. Figures 7-25 and 7-30 provide diagrams for connecting RS-232 cables between PDIU-DIs and Toshiba lap top, and IBM, XT and AT PCs.*

- 4) Set the PDIU-DI DIP switch (SW1-1 ~ 4) for the desired application. Figure 7-32 shows the DIP switch locations and Paragraph 10.30 describes switch functions.
- 5) Access **Program 20** to configure the PDIU-DI for DTE-type connection and **Program 39** for data button assignments of the digital telephone connected to the PDIU-DI.

**Program 20**

- The port number entered for the PDIU-DI in **Program 20** is the port number of the digital telephone to which the PDIU-DI is connected.
- **LED 01:** Should always be ON for PDIU-DI ports.
- **LED 02:** Should be ON for PDIU-DI ports, unless the PC user will never use DIU AT commands (other than ATDD, ATDT, and ATD) and never require the PDIU-DI to send result codes to display on the PC display screen. Frequently, it is difficult to determine the full extent of these

requirements; so it is recommended to turn LED 02 ON. See the *Data Interface User Guide* for information regarding DIU AT commands and result codes.

- **LEDs 03 and 04:** Should be OFF for PDIU-DI ports.
- **LED 05:** Should be ON if the system is installed behind a PBX or Centrex that uses access codes to make external calls or to insert a pause following DIU access of an outside line.
- **LEDs 17 ~ 20:** Used to establish data security groups. PDIU stations are only allowed to make calls to PDIUs in the same data group to which they are assigned.

**Program 39**

- The following data call buttons can be assigned digital telephones equipped with PDIU-DIs: **Data Call**, and **Modem**. Assign **SD** buttons to data devices as required. Do not assign **DSS** buttons to data devices; **DSS** buttons are used for voice calls only.

**10.50 PDIU-DS to Printer Installation**

**10.51** STRATA DK8 and DK16 enables serial printers (laser, dot matrix, or other types) to be connected to stand-alone data interface units (PDIU-DSs). Digital telephones equipped with PDIU-DIs can share access to these printers. Serial printers operate as DCE or DTE devices, depending on the vendor; the PDIU-DS can be connected to either type, since it can be configured as a DTE or DCE device. (The PDIU-DS comes from the factory configured as a DCE device.) Follow the steps below to install the PDIU-DS to a serial printer.

**NOTES:**

1. Only serial printers (not parallel) that conform to EIA RS-232 signaling requirements can be connected to PDIU-DSs.
2. In rare applications, it may be desired to connect printers to PDIU-DIs. Refer to the printer's installation instructions.

INSTALLATION-PERIPHERALS  
SECTION 100-816-207  
MARCH 1993

- 1) Consult the serial printer's documentation and determine if the printer operates as a DCE or DTE device:
  - If the printer is a DCE device: Disassemble the PDIU-DS and configure it to operate like a DTE device by placing the jumper plugs (**P1** ~ **P9**) in the "B-C" (MODEM) position. Reassemble the PDIU-DS, and mark "B-C" on the bottom identification label for future reference. (Paragraph 10.70 provides PDIU-DS disassembly/assembly instructions, and Figure 7-31 provides jumper plug information.)
  - If the printer is a DTE device: It may not be necessary to disassemble the PDIU-DS, since it comes direct from the factory configured as a DCE device. However, if uncertain, disassemble the PDIU-DS and verify that jumper plugs (**P1** ~ **P9**) are in the "A-B" (DTE) position. Reassemble the PDIU-DS and mark "A-B" on the bottom identification label for future reference. (Paragraph 10.70 provides PDIU-DS disassembly/assembly instructions, and Figure 7-31 provides jumper plug information.)
- 2) Connect the PDIU-DS to the appropriate digital telephone circuit per wiring diagrams in Section 100-816-208 and information provided in Section 100-816-206.
- 3) Connect the appropriate RS-232 cable between the printer and the PDIU-DS (see Figure 7-27 and 7-29 for an example printer cable connection).
- 4) If steps 2 and 3 are done properly, the Power and Ready LEDs on the PDIU-DS should light when the printer is turned on and ready.
- 5) Set the PDIU-DS DIP switch (**SW1-1** ~ **4**) for the desired application. Figure 7-32 shows the DIP switch locations and Paragraph 10.30 describes switch functions.

**NOTE:**

*If using Toshiba computers and printers with X-On/X-OFF flow control, set SW1-(4) "ON" on the DIU connected to the computer and DIU connected to the printer.*

**IMPORTANT NOTE!**

**Check the printer's serial documentation for correct RS-232 pin requirements. The requirements vary with each manufacturer.**

- 6) Use **Program 20** to configure the PDIU-DS to connect to a serial printer (see Programming Section 100-816-302 for instructions and record sheets).
  - **LED 01:** Should always be ON for PDIU-DS ports.
  - **LED 02:** Should be OFF for PDIU-DS ports connected to printers.
  - **LED 03:** Should be OFF for PDIU-DS ports that connect to DTE- or DCE-type printers.
  - **LED 04:** Should always be ON for PDIU-DS ports.
  - **LED 05:** Should be OFF for PDIU-DS ports connected to printers.
  - **LEDs 17 ~ 20:** Data security groups can be used to allow or deny digital telephones equipped with PDIU-DIs access to PDIU-DS ports connected to a printer. DIU stations can only make data calls to DIUs in the same data security group.
- 7) **Program 22** should be used to configure PDIU-DSs to hunt if more than one PDIU-DS connected to the same printer/server.

**10.60 PDIU-DS to Modem Installation**

**10.61** STRATA DK16 enables asynchronous-type (not synchronous) modems to be connected to PDIU-DSs. This allows PDIU-DI equipped digital telephones that are connected to personal computers, terminals, and other devices to share access to a modem or modem pool.

**IMPORTANT NOTE!**

*Modems must be "smart modems" that respond to AT commands and return result codes. Modems are customer-supplied.*

**10.52** A modem(s) can be accessed internally for outgoing data calls or externally for incoming data calls. Modems operate as DCE devices; so PDIU-DSs that are connected to them must be configured to operate like a DTE device. In the example installation in Figure 7-24, the line side of the two modems are connected to KSTU/PSTU/PESU ports to establish a modem pool; however, the line side of modems could be connected directly to a dedicated CO line. If modems are connected directly to telephone network CO lines, automatic transfer of CO line voice calls to system modems (data call) will not function as described in the *Data Interface User Guide*. For best operation and utilization of CO lines and modems, it is recommended to connect modems to QSTU, PSTU or KSTU standard station ports in a modem pool configuration. The RS-232 side of the modem connects to the PDIU-DS with standard RS-232 cables; the PDIU-DS line side (RJ-11 connector) always connects to its own individual digital port. Use the following instructions to install modems to PDIU-DSs.

- 1) Configure the PDIU-DS as a DTE device: Disassemble the PDIU-DS and place jumper plugs **P1 ~ P9** in the "B-C" position (MODEM). Reassemble the PDIU-DS and mark "B-C" on the bottom identification label for future reference. (Paragraph **10.70** provides PDIU-DS disassembly/assembly instructions and Figure 7-31 provides jumper plug information.)
- 2) Connect the PDIU-DS to the appropriate Digital port circuit per the wiring diagrams in Section **100-816-208**.
- 3) Connect the appropriate RS-232 cable between the modem and the PDIU-DS. Figure 7-28 shows an example PDIU-DS to "smart modem" RS-232 connection.

**IMPORTANT NOTE!**

*All ten PDIU-DS EIA leads (signals) should be connected to the modem. Consult the modem's documentation for correct RS-232 pin requirements; the requirements may vary with each manufacturer.*

- 4) Connect the line side of the modem to a QSTU, PSTU, KSTU or PESU standard telephone circuit or a dedicated CO line (consult the modem's documentation to install the it to a CO line). Section **100-816-208** provides QSTU, KSTU/PESU/PSTU station port wiring information.
- 5) Set the PDIU-DS DIP switch (**SW1-1 ~ 4**) for the desired application. Figure 7-32 shows the DIP switch location and Paragraph **10.30** describes switch functions.

**NOTE:**

*If the modem tracks carrier detect (DCD, AT&C1), SW1(4) should be "ON," and SW1(2) should be OFF when PDIU-DS is connected to a modem.*

- 6) Use the programs below to configure the PDIU-DS to connect to an asynchronous modem (see Programming Section **100-816-302** for explanations and record sheets).

**Program 20**

- **LED 01:** Should always be ON for PDIU-DS ports
- **LED 02:** Should be ON for PDIU-DS ports connected to modems, enabling the use of AT commands and result codes when incoming calls are made from outside the system to modems connected to PDIU-DSs.
- **LED 03:** Should be set ON for PDIU-DS ports connected to modems.
- **LED 04:** Should always be ON for PDIU-DS ports.
- **LED 05:** Should be ON if the system is installed behind a PBX/Centrex that uses access codes to place outgoing trunk calls.

- **LED 06:** Should be ON for DIUs connected to modems. With this feature turned on, the DIU will send a one-second release signal on the DTR to drop the modem when the data user presses the **Data Release** button on the telephone.
- **LEDs 17 ~ 20:** Data security groups can be used to allow or deny digital telephones equipped with PDIU-DIs access to the PDIU-DS ports connected to a modem. DIU stations can only make data calls to DIUs in the same data security group.

#### Program 21

- For each PDIU-DS/modem pair, assign the digital, QSTU, KSTU, and PSTU (or PESU) ports that will be connected to the PDIU-DS and modem, respectively.

#### Program 22/33

- If more than one modem/PDIU-DS pair is configured as a system modem pool, the PDIU-DSs should be set to hunt each other in **Program 22**. The modem QSTU, PSTU, KSTU, or PESU ports should be set to hunt each other in **Program 33**.

#### Program 31

- LED 18 should be turned on for all QSTU, KSTU, PESU or PSTU station ports that are connected to modems. This provides data security by preventing executive or privacy override of modem calls.

### 10.63 Modem Setup Recommendations

- 1) Always change the escape sequence of the telephone PDIU-DI from default (+++) to some other ASCII character (ATS2=XX command to PDIU-DI). This allows placing the PDIU-DI or modem into the command mode selectively. The ATS2=XX command should be in the modem initialization command of the communication software of the PC connected to the PDIU-DI (XX = new ASCII Escape character). This will ensure that the new Escape sequence is restored if the telephone or PDIU-DI is unplugged.

- 2) Set the modem to recognize the DTR signal to disconnect (AT&D2 command to modem).
- 3) When the modem tracks the DCD signal, issue AT&C1 command to modem.

### 10.70 PDIU-DS Disassembly and Assembly

**10.71** To set the jumper plugs (P1 ~ P9) on the PCB inside the PDIU-DS for DCE or DTE operation, the PDIU-DS must be disassembled. Disassemble the PDIU-DS in accordance with the following steps:

#### 10.72 Disassembling the PDIU-DS

- 1) Remove the four screws securing the bottom panel to the rest of the unit (see Figure 7-33). These screws are not captive; so place together where they can be easily accessed.
- 2) Remove the bottom panel.
- 3) Remove the PCB inside the PDIU-DS by lifting the back panel from its side grooves.
- 4) Turn the PCB over and set the jumper plugs (P1 ~ P9) as follows:
  - If the PDIU-DS is connected to a DTE, set the plugs to the "A-B" position.
  - If the PDIU-DS is connected to a DCE device, set the plugs to the "B-C" position.

#### NOTE:

*Do not cut PDIU-DS PERCEPTION jumper wire for STRATA DK8 or DK16 installations.*

#### 10.73 Assembling the PDIU-DS

- 1) Position the back panel to the PCB (see Figure 7-33).
- 2) Slide the back panel down into its side grooves.
- 3) Attach the bottom panel, and secure with the four non-captive screws.

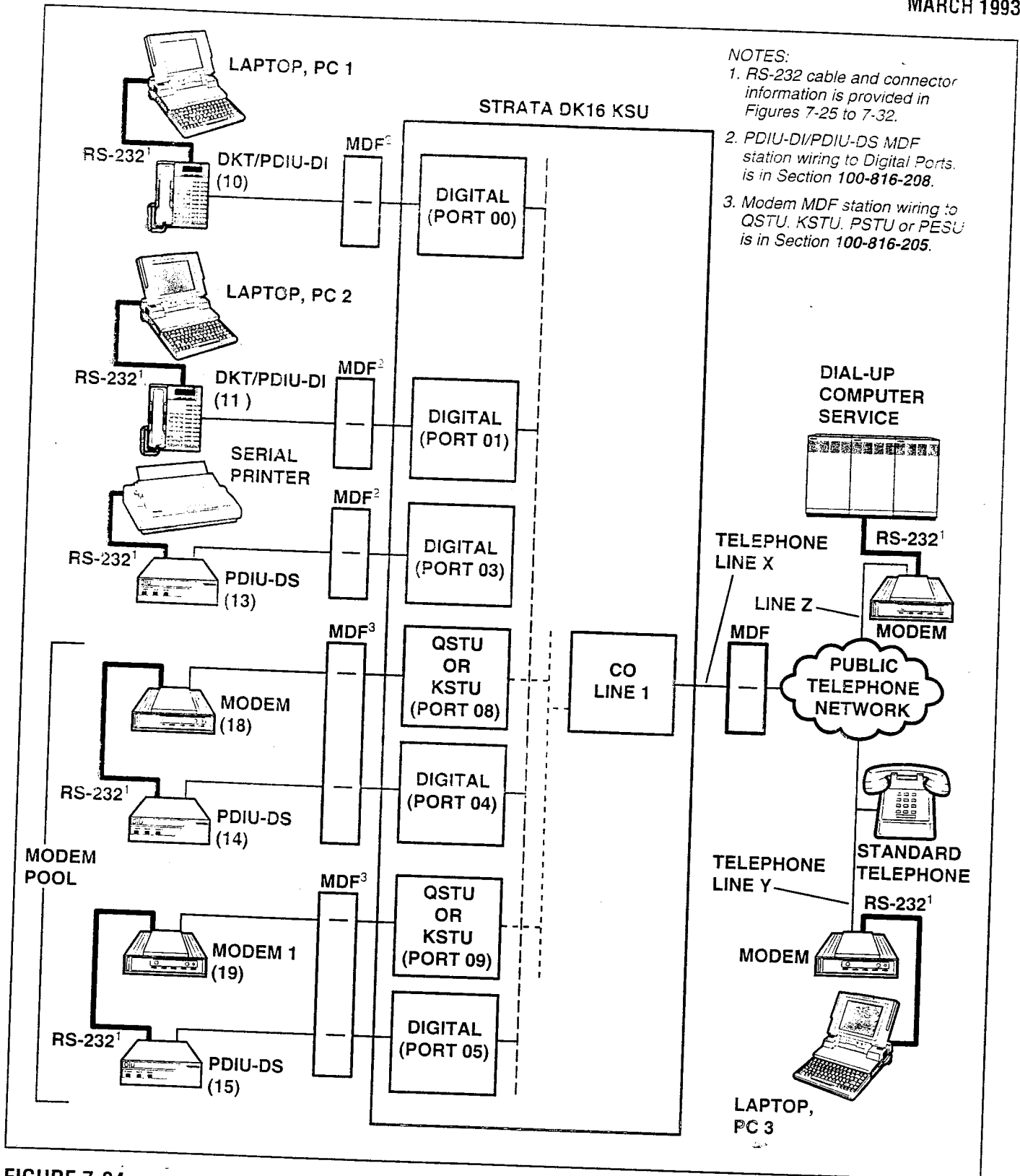
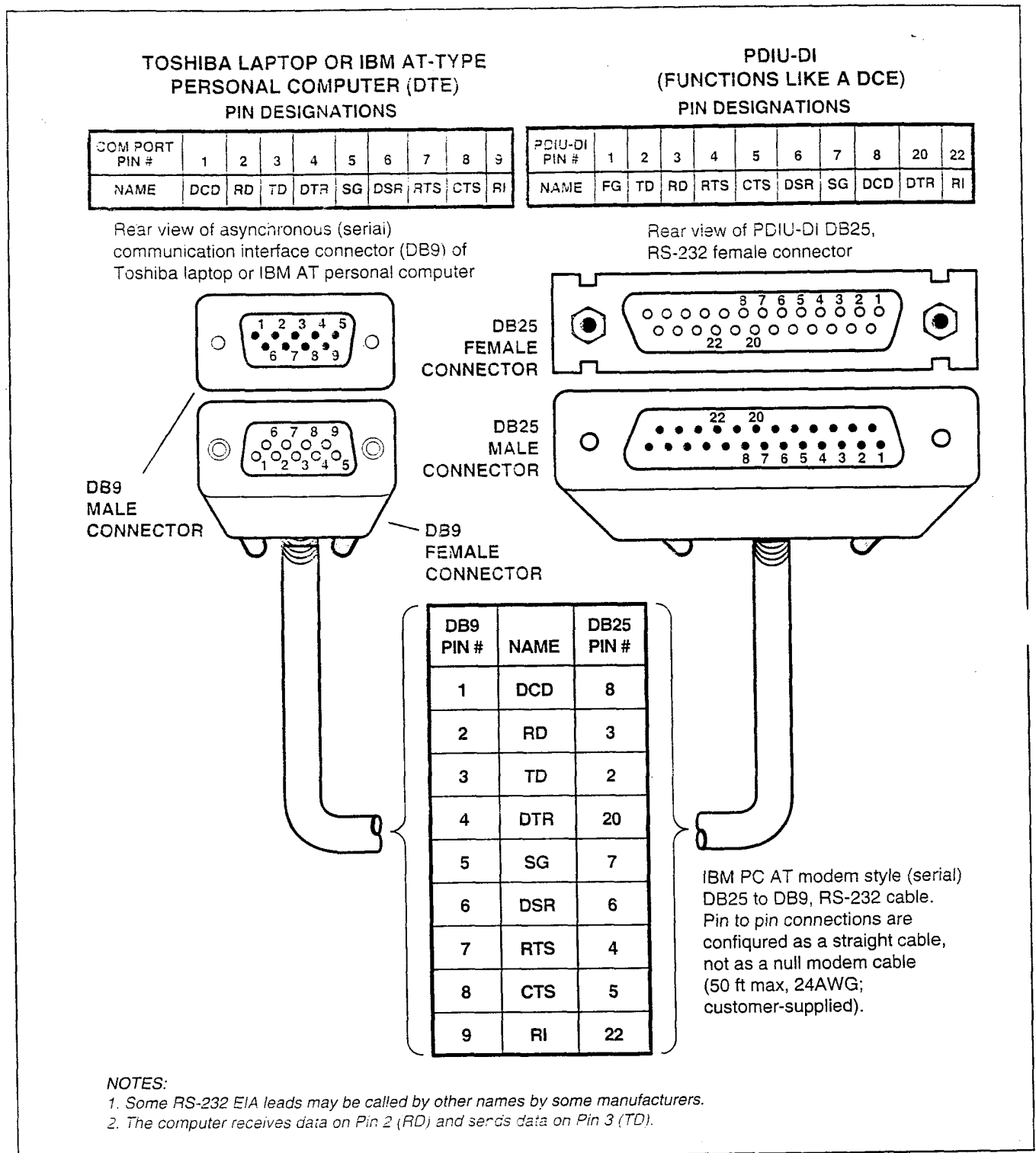
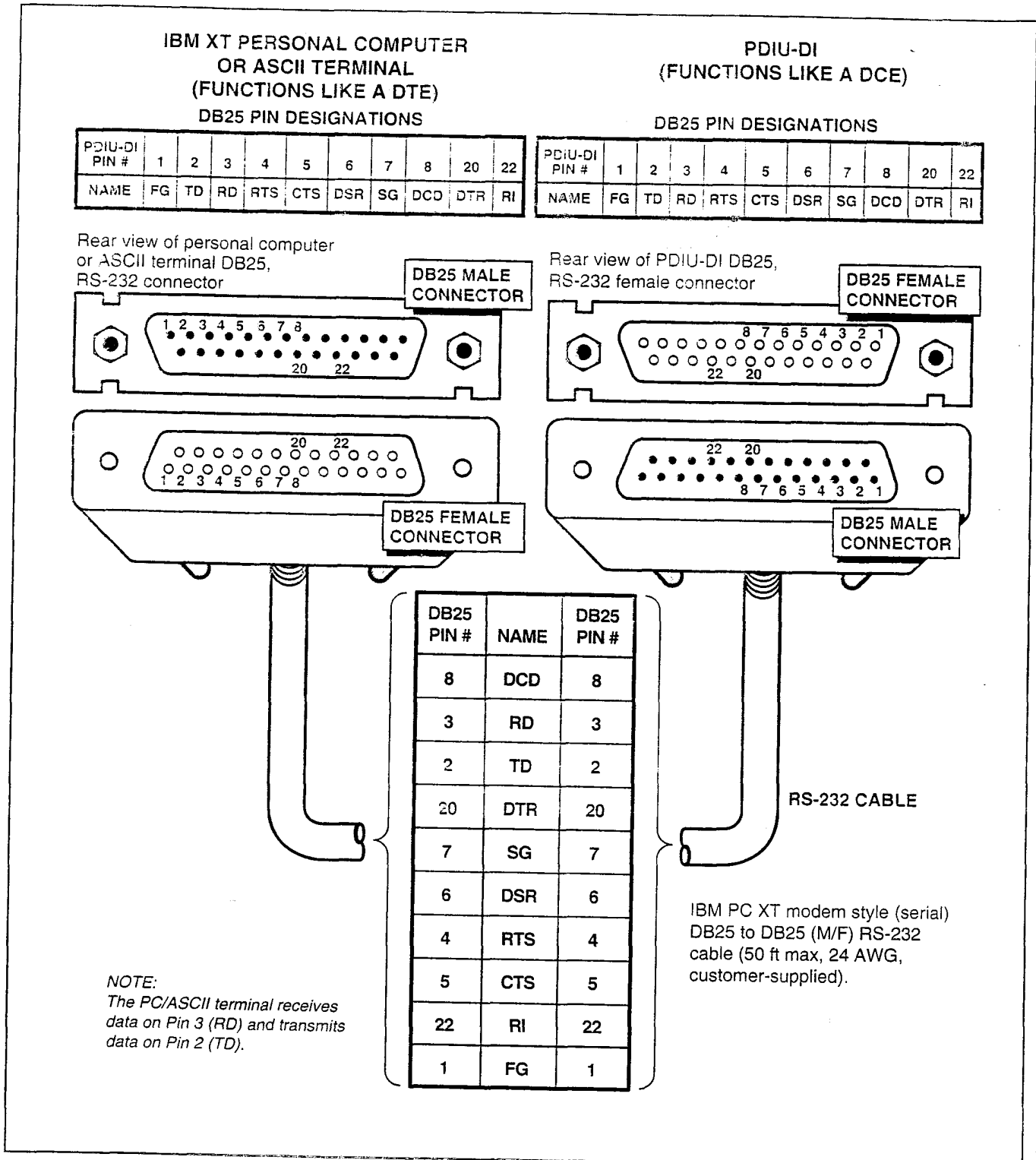


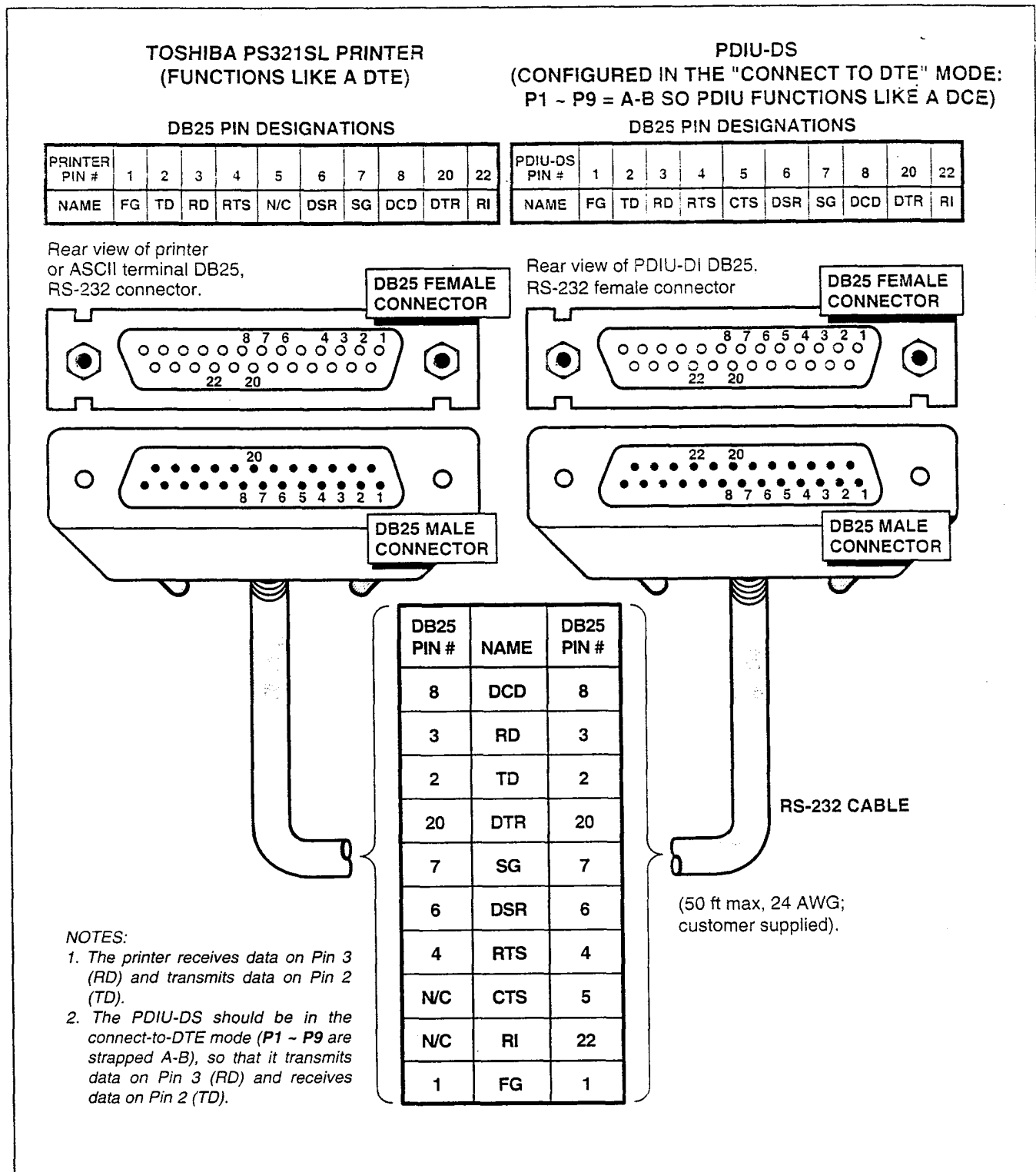
FIGURE 7-24  
DK8 OR DK16 DATA INSTALLATION EXAMPLE BLOCK DIAGRAM



**FIGURE 7-25  
 DK8 AND DK16 PDIU-DI TO IBM AT-TYPE COMPUTER, RS-232 CONNECTOR/CABLE CONNECTIONS**

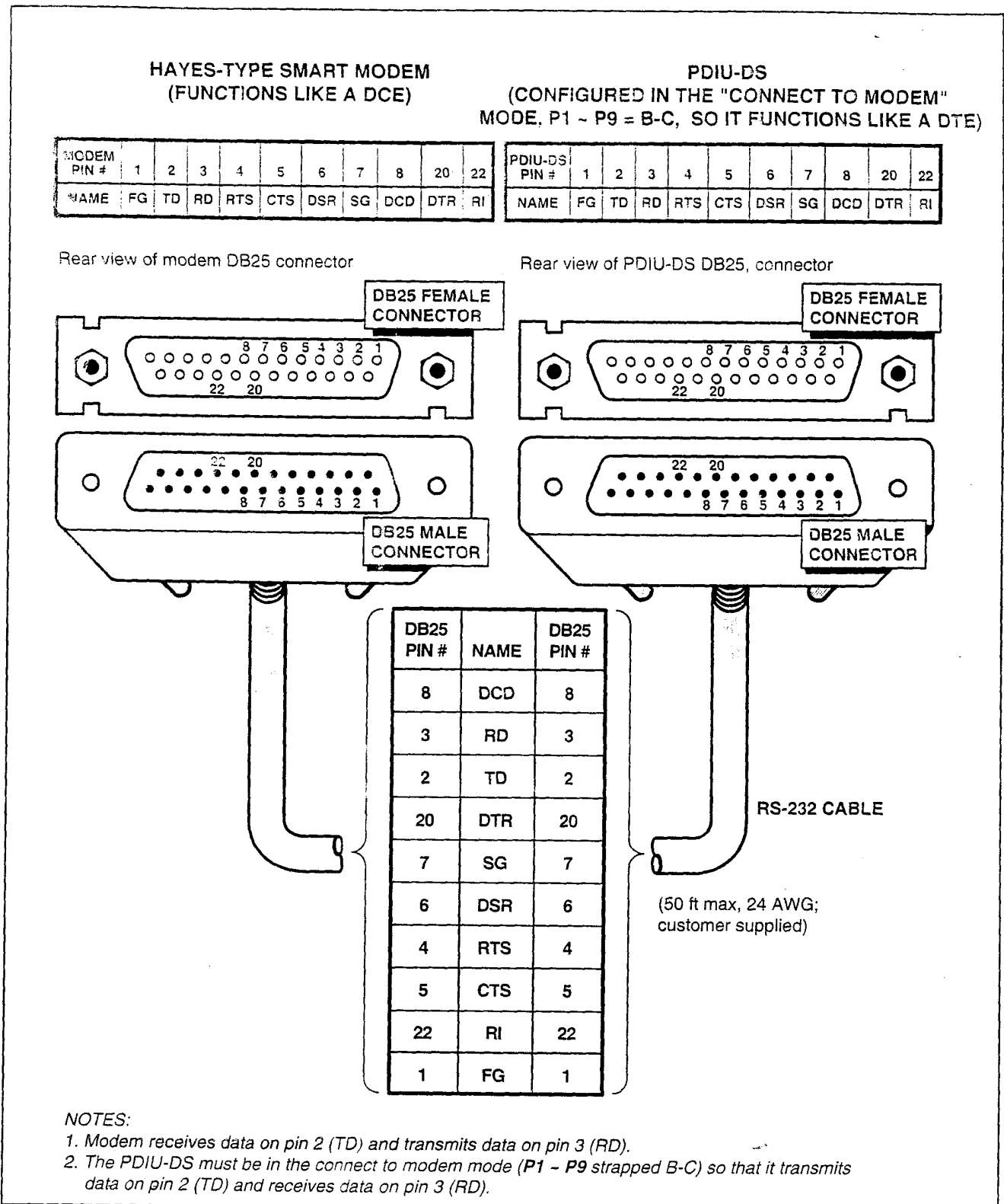


**FIGURE 7-26  
DK8 AND DK16 PDIU-DI TO IBM XT-TYPE COMPUTER, RS-232 CONNECTOR/CABLE CONNECTIONS**



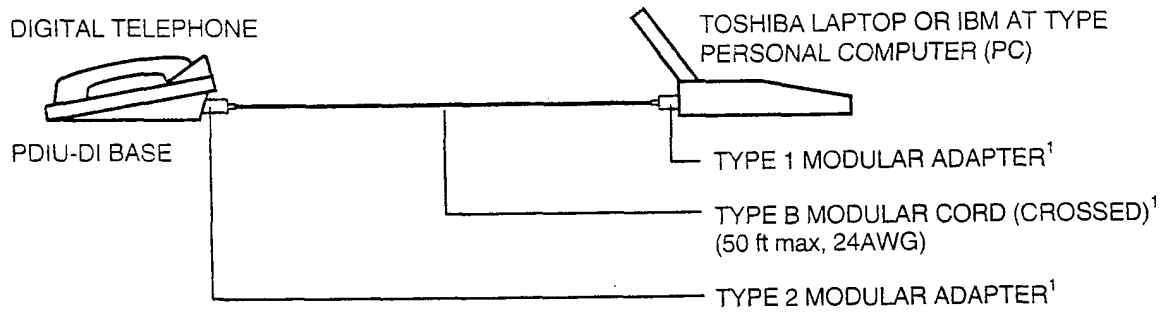
**FIGURE 7-27**  
**DK8 AND DK16 PDIU-DS TO TOSHIBA PRINTER, RS-232 CONNECTOR/CABLE CONNECTIONS**





**FIGURE 7-28**  
**DK8 AND DK16 PDIU-DS TO HAYES-TYPE SMART MODEM, RS-232 CONNECTOR/CABLE CONNECTIONS**

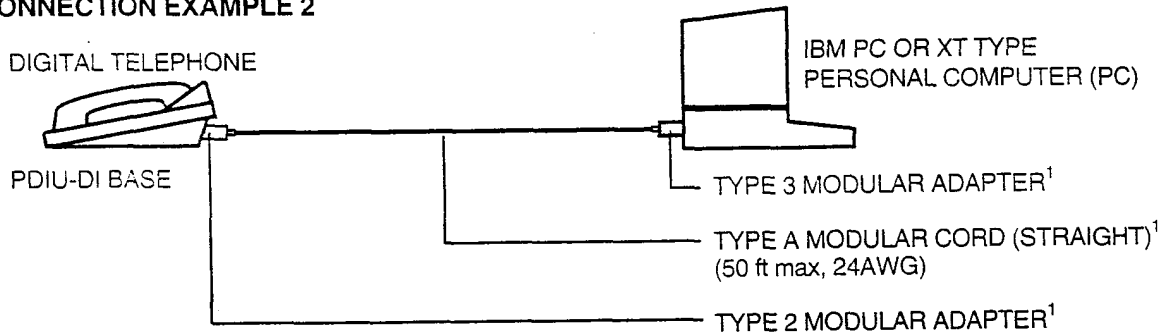
**CONNECTION EXAMPLE 1**



**IMPORTANT!**

*Will not function with applications that require the RI signal to PC.*

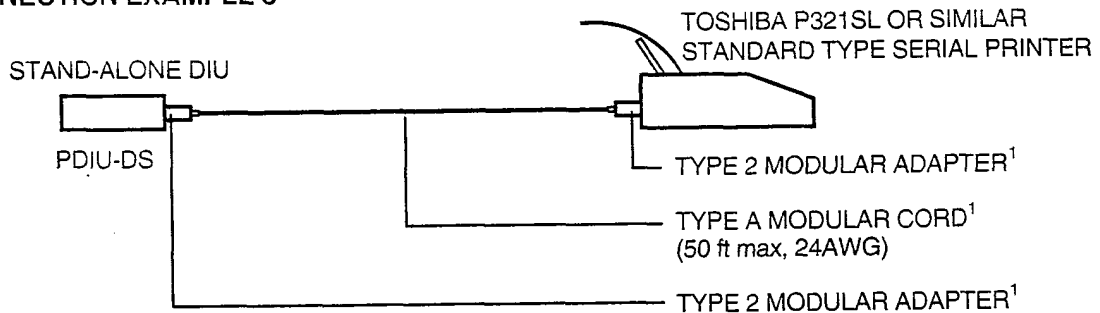
**CONNECTION EXAMPLE 2**



**IMPORTANT!**

*Will not function with applications that require the RI signal to PC.*

**CONNECTION EXAMPLE 3**



**NOTES:**

1. See Figure 7-30 for detailed pin out information of modular cords and adapters.
2. Never use modular cords and adapters when connecting a PDIU-DI/PDIU-DS to a modem.
3. Connection examples 1 and 2 work when using the PDIU-DI to make calls with personal computer applications (auto-dialers, printer sharing, outgoing modem calls, etc). If the PC PDIU-DI must receive calls, the RI lead is normally required; therefore, a standard RS-232 cable must be used (see Figures 7-25 and 7-28).
4. In Connection Example 3, PDIU-DS must be in the connect to DTE mode (P1 ~ P9, strapped A-B).
5. All modular cords and adapters are customer-supplied.

**FIGURE 7-29**  
**DK8 AND DK16 PDIU-DI/PDIU-DS MODULAR CABLE/RJ-45 ADAPTER CONNECTIONS**

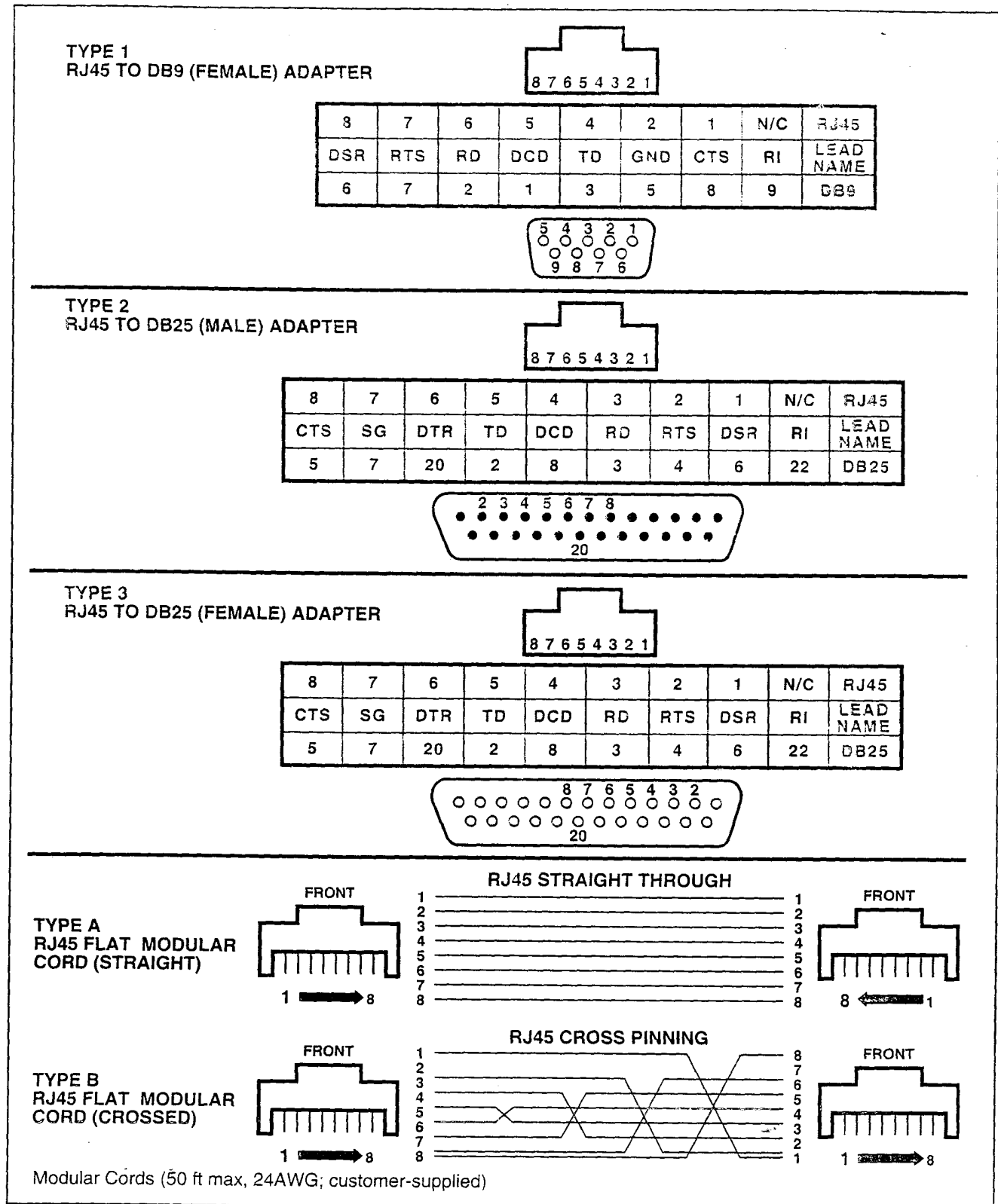


FIGURE 7-30  
DK8 AND DK16 PDIU-DI/PDIU-DS MODULAR CORDS AND RJ-45/RS-232 ADAPTER PIN CONNECTIONS

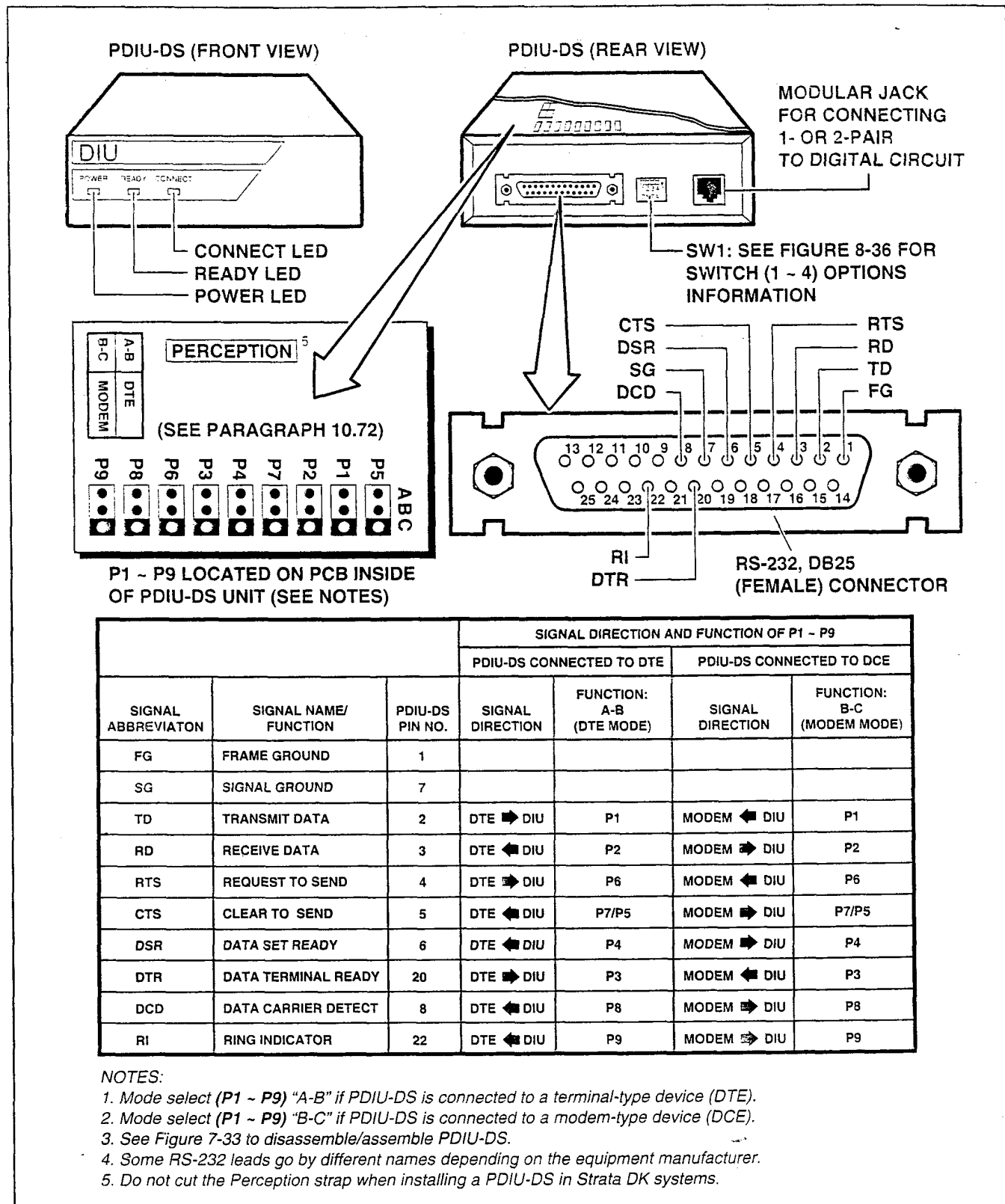


FIGURE 7-31  
DK8 AND DK16 PDIU-DS JUMPER PLUG OPTIONS/RS-232 CONNECTOR INFORMATION

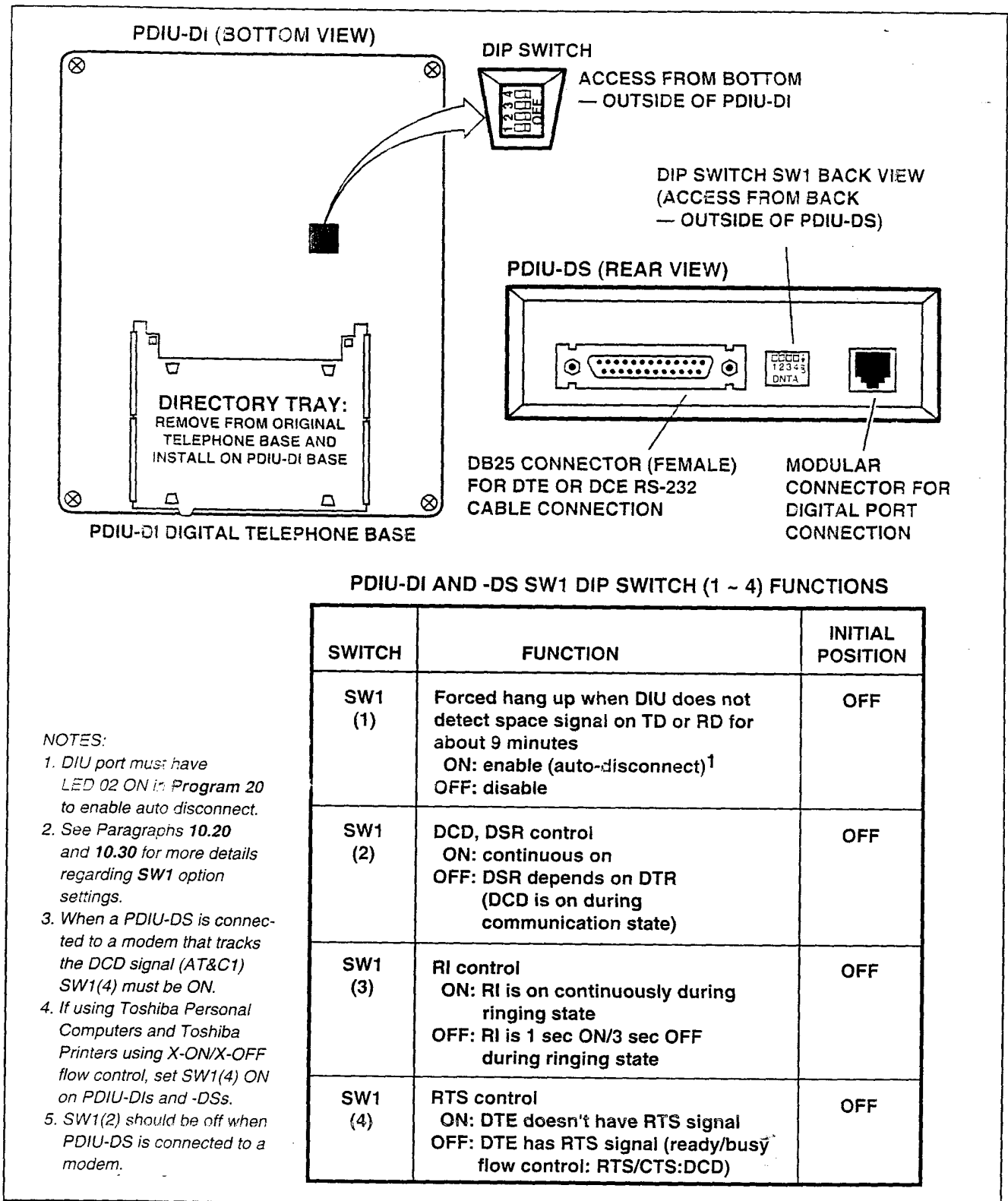


FIGURE 7-32  
DK8 AND DK16 PDIU-DI/PDIU-DS SW1 DIP SWITCH INFORMATION

INSTALLATION-PERIPHERALS  
SECTION 100-816-207  
MARCH 1993

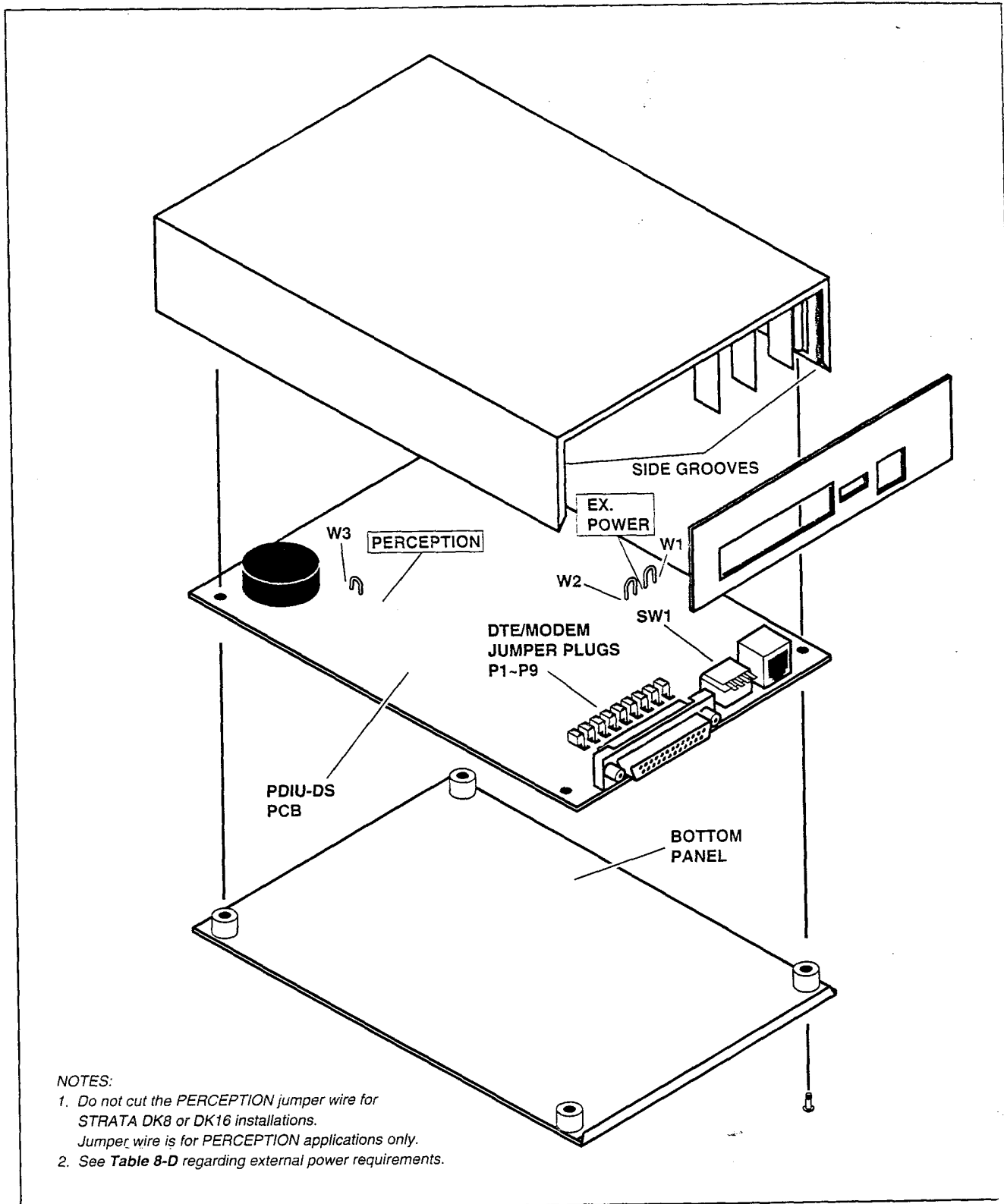


FIGURE 7-33  
DK8 AND DK16 PDIU-DS DISASSEMBLY/ASSEMBLY DIAGRAM

### 10.80 PDIU-DI/PDIU-DS Installation Tests

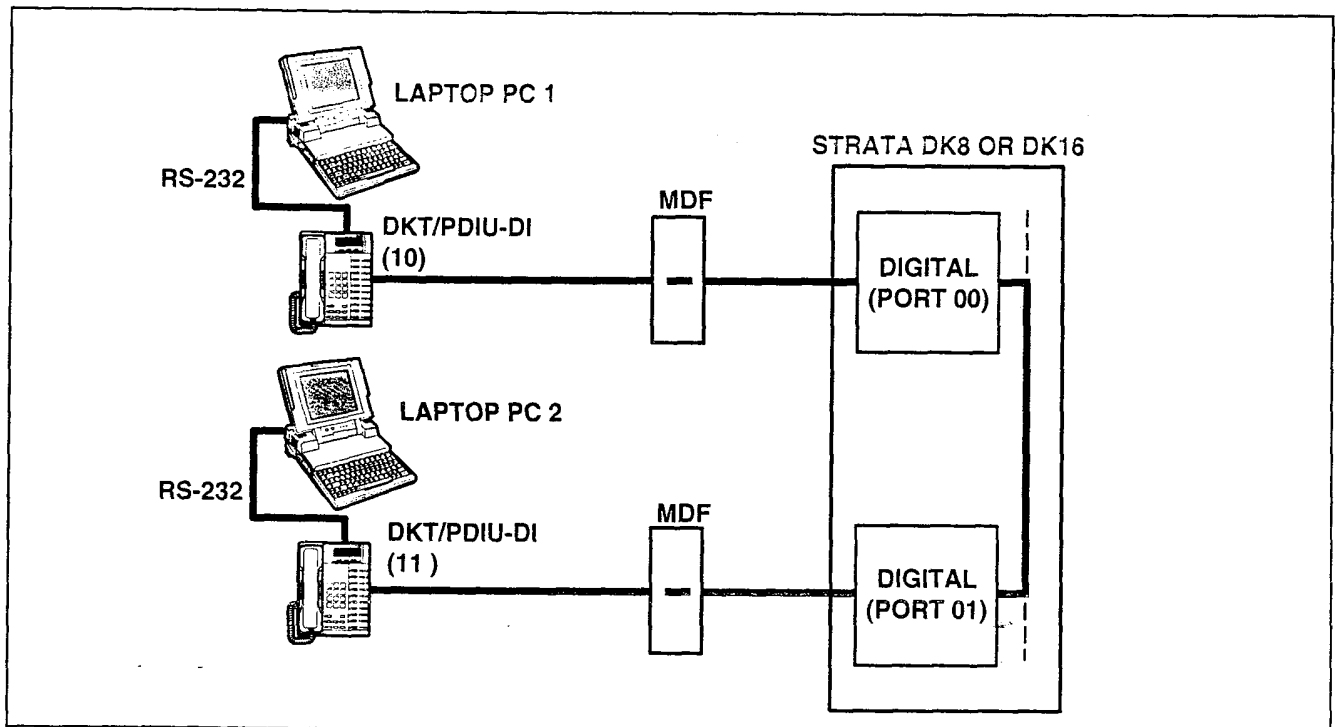
**10.81** Paragraphs **10.82 ~ 10.86** provide tests for five DIU call applications. The telephone and port numbers used in these figures are provided for explanation purposes only; when actually testing, use port and telephone numbers appropriate for the system. Each of these tests can be conducted with manual dialing from a digital telephone's dialpad or AT dialing from a personal computer's keyboard; however, only the preferred method of dialing for application is presented.

#### 10.82 PC-to-PC Test Call Using AT Commands (see Figure 7-34)

1) DIU Programming:

- **Program 20:** Ports 00 and 01. LEDs 01, 02, and 17 ON; all other LEDs OFF.
- **Program 39:** Ports 00 and 01. **Data Call** (56) and **Data Release** (54) buttons should be provided.
- Default settings for PDIU-DI S-Registers.

- 2) Make sure PC 1 and PC 2 are on-line with a communications software package and that the communication parameters of each PC and communication software package are set to the same values (data transmission rate, parity, data bits, stop bits, flow control, etc.).
- 3) From PC 1's keyboard, type **ATDD11** and press **ENTER** (AT commands must be capital letters).
  - The Data Call LEDs will be lit on DKT 10 and 11
  - PC 1 displays, CONNECT XXXX.
  - PC 2 displays, RING.
  - PC 1 and PC 2 are connected as shown by the thick solid lines. PDIU-DIs are now in the communication mode.
- 4) Typing from PC 1 keyboard will display on PC 2 display and vice versa.
- 5) To terminate the call: Press **Data Release**, or;
  - a) Type XXX from either PC keyboard.
    - The PC screen displays, OK.



**FIGURE 7-34**  
**DK8 AND DK16 PC TO PC TEST CALL USING AT COMMANDS**

**INSTALLATION-PERIPHERALS**  
**SECTION 100-816-207**  
**MARCH 1993**

- b) Type **A T H** from the PC keyboard used in step 5a.
- PC 1 and PC 2 screens both display, NO CARRIER.
  - The Data Call LEDs on each DKT are off.

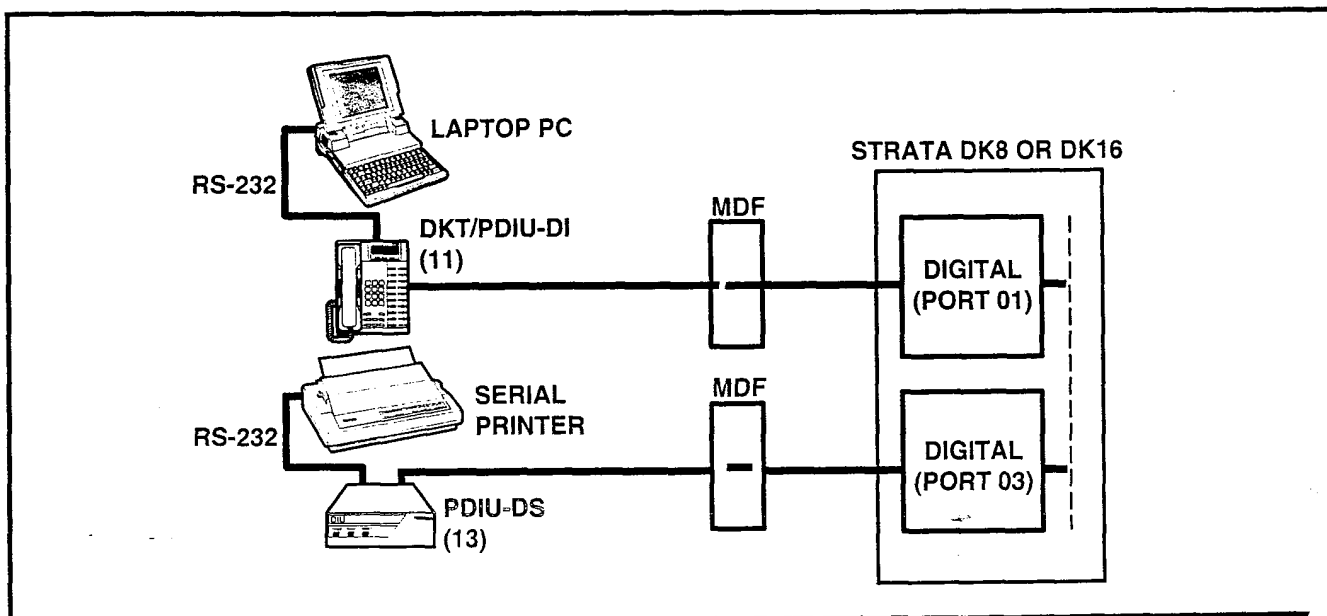
XXX = PDIU-DI escape sequence (see Paragraph 10.63)

**10.83 PC to Printer Test Call Using Manual Dialing (see Figure 7-35)**

- 1) DIU Programming:
  - **Program 20:** Port 01. LEDs 01, 02, and 17 ON; all other LEDs OFF.
  - **Program 20:** Port 03. LEDs 01, 04, and 17 ON; all other LEDs OFF.
  - **Program 39:** Port 01. **Data Call** (56) and **Data Release** (54) buttons should be provided.
  - Default settings for PDIU-DI, S-Registers.
- 2) Make sure the PC is configured to print data from its serial COM port (the PC COM port connected to DKT/PDIU-DI port 01). This is

normally accomplished using the DOS and MODE commands.

- 3) Using the manufacturer's documentation, make sure the communication parameters (data speed, parity, data bits, stop bits, etc.) of the PC COM port match the printer's serial interface parameters.
- 4) To connect the PC to the printer, press the DKT's **Data Call** button and dial **1 3**.
  - The CONNECT on the PDIU-DS will be lit.
  - The connection between the PC and the printer is completed, as shown by the thick lines above (PDIU-DS 13 is in the communication mode).
  - If busy tone is sent to the DKT, the connection is not complete; press **Data Release** and try step 4 again.
- 5) Operate the PC to print data as required.
- 6) To terminate the call, press the DKT's **Data Release** button.



**FIGURE 7-35**  
**DK8 AND DK16 PC TO PRINTER TEST CALL USING MANUAL DIALING**



10.84 Internal PC to External PC Test Call Using AT Commands (see Figure 7-36)

- 1) DIU Programming:
  - **Program 20:** Port 00. LEDs 01, 02, and 17 ON; all other LEDs OFF.
  - **Program 20:** Port 04. LEDs 01, 02, 03, 04, 06, and 17 ON; all other LEDs OFF.
  - **Program 21:** Digital port 04 assigned with KSTU port 08.
  - **Program 39:** Port 00. **Data Call** (56), **Data Release** (54), and **Modem** (55) buttons should be provided.
  - Default settings for PDIU-DI and PDIU-DS S-Registers.
- 2) Make sure PC 1 and PC 2 are on-line with a communications software package and that the communication parameters of each PC and communication software package are set to the same values (data transmission rate, parity, data bits, stop bits, flow control, etc.).

- 3) From PC 1's keyboard, type **ATDD14** and press **ENTER** (AT commands must be capital letters).
  - The Data Call LED on DKT 14 will be lit.
  - The CONNECT LED on PDIU-DS 14 will be lit.
  - The screen on PC 1 displays, **CONNECT XXXX**, where XXXX is the data transmission speed set by the communications software.
  - At this time, PC 1 and PDIU-DS 14 are connected as shown by the thick lines above (PDIU-DS 14 is in the communication mode); PC 1 is now linked directly to the RS-232 side of the internal modem; PC 1 can issue AT commands to the internal modem, which is now in the command mode.
  - If Digital/PDIU-DS port 04 is the only DIU port connected to the modem (**Program 20, LED 03 ON**), the Modem LEDs on all DKTs will be lit.

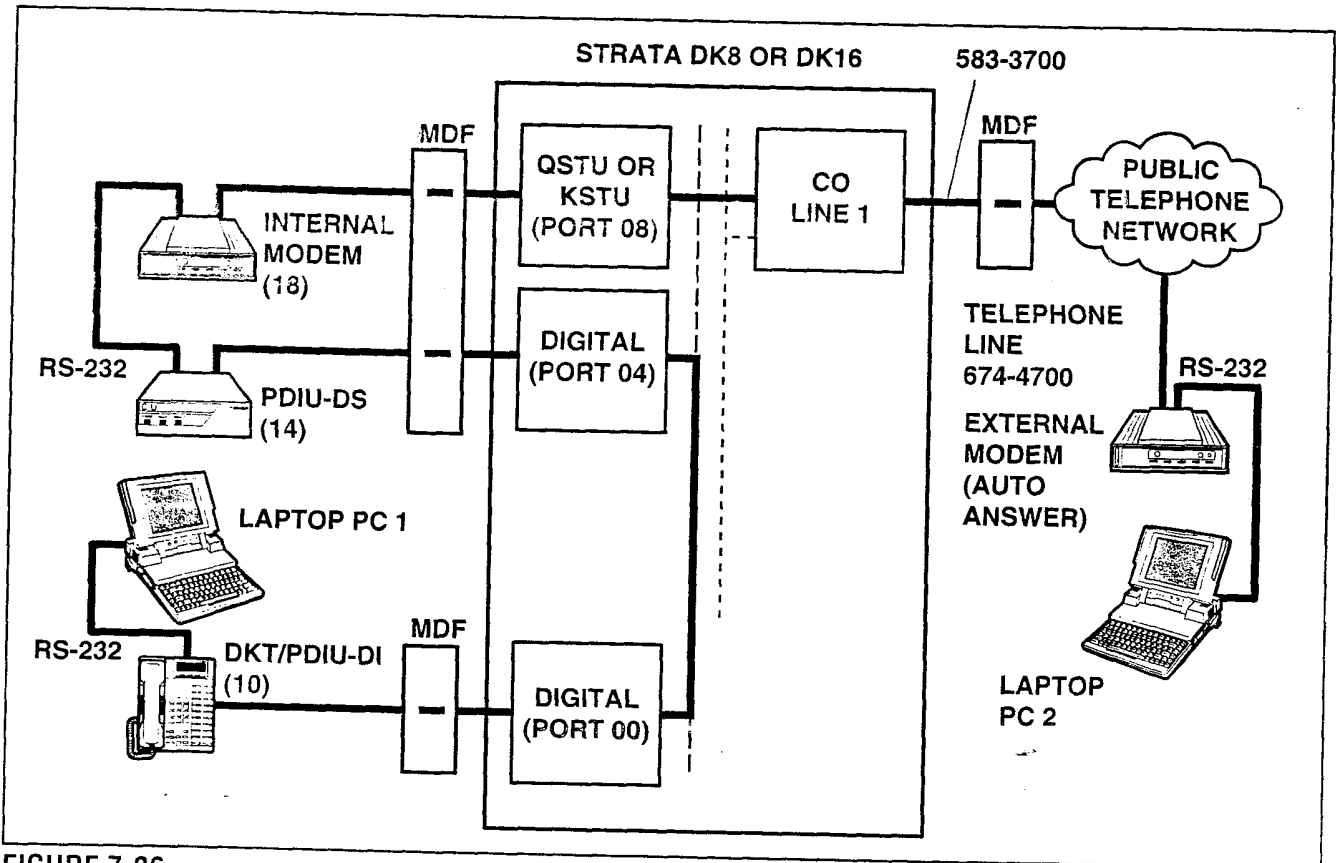


FIGURE 7-36  
DK8 AND DK16 INTERNAL PC TO EXTERNAL PC TEST CALL USING AT COMMANDS

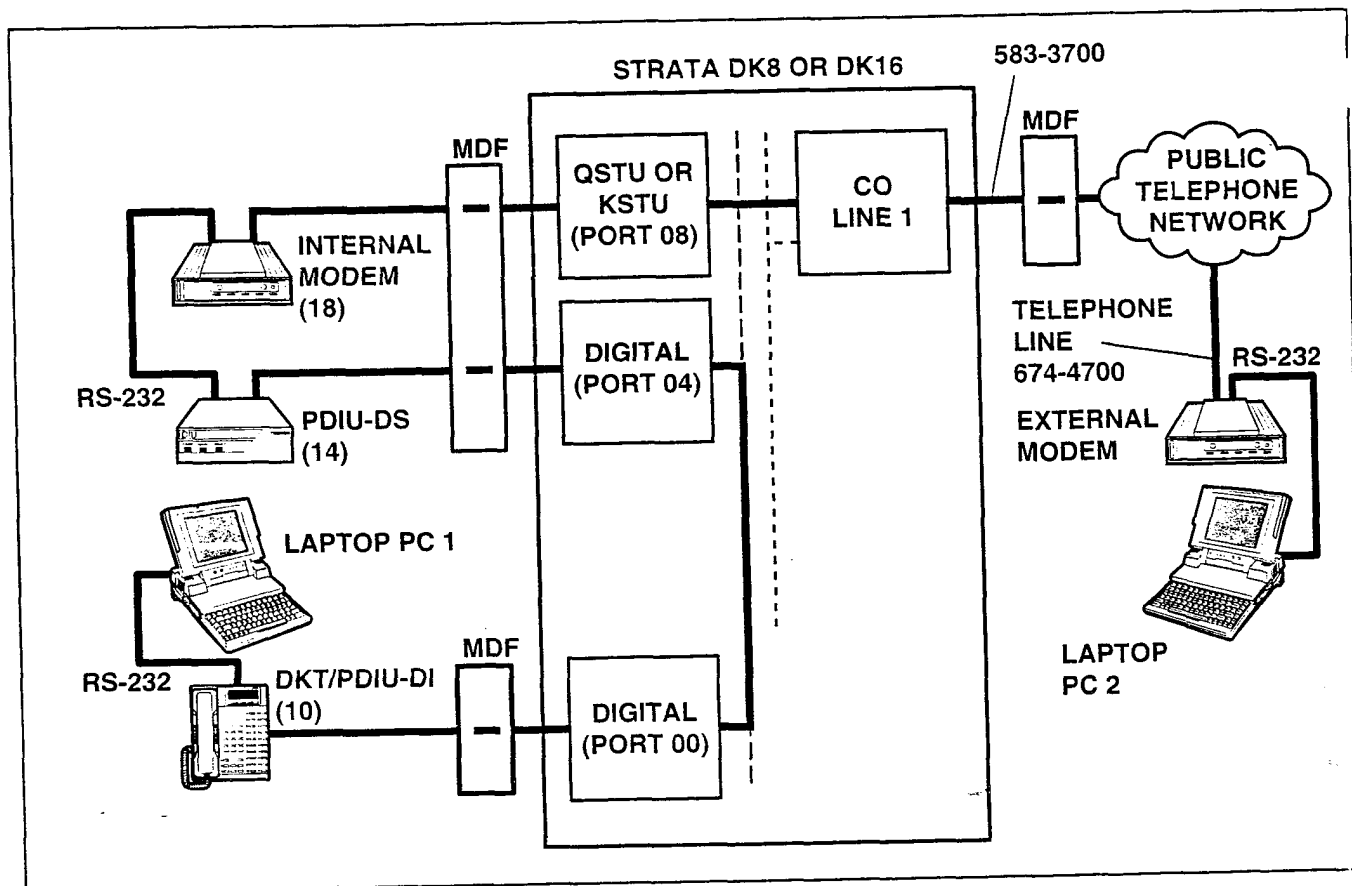
**INSTALLATION-PERIPHERALS**  
**SECTION 100-816-207**  
**MARCH 1993**

- 4) From PC 1's keyboard, type **ATDT7016744700** and press **ENTER**.
  - The internal modem (18) goes off-hook, dials 701 to seize the CO line, and then dials the external modem's telephone number (674-4700).
  - The external modem rings and auto answers; the modems handshake and establish communications.
  - If the modems send result codes, the screen on PC 1 displays, **CONNECT XXXX**, where XXXX is the data transmission speed set by the communication software.
  - At this time PC 1 and PC 2 are connected, as shown by the thick lines above, to exchange data (file transfers, type messages, etc.).

- 5) To terminate the call: Press the telephone **Data Release** button and:
  - a) Type **+++** from PC2 keyboard.
    - The PC screen displays. **OK**.
  - b) Type **ATH** from the PC keyboard used in step 5a.
    - PC 1 and PC 2 screens both display, **NO CARRIER**.
    - The Data Call LED on DKT 10 will be unlit.

**10.85 External PC to Internal PC Test Call Using AT Commands (see Figure 7-37)**

- 1) DIU Programming:
  - **Program 20:** Port 00. LEDs 01, 02, and 17 ON; all other LEDs OFF.



**FIGURE 7-37**  
**DK8 AND DK16 EXTERNAL PC TO INTERNAL PC TEST CALL USING AT COMMANDS**

- **Program 20:** Port 04. LEDs 01, 02, 03, 04, 06, and 17 ON; all other LEDs OFF.
  - **Program 21:** Digital port 04 assigned with PSTU port 08.
  - **Program 39:** Port 00. **Data Call** (56), **Data Release** (54), and **Modem** (55) buttons should be provided.
  - **Program 81:** Port 08. LED 01 ON (CO line 01 rings QSTU/KSTU port 08).
  - Internal modem: set to auto answer (S0=1).
  - Default settings for PDIU-DI and PDIU-DS, S-Registers.
- 2) Make sure PC 1 and PC 2 are on-line with a communications software package and that the communication parameters of each PC and communication software package are set to the same values (data transmission rate, parity, data bits, stop bits, flow control, etc.).
- 3) From PC 2's keyboard, type **ATDT5833700** and press **ENTER**.
- The external modem originates the call to STRATA DK16 CO line 01.
  - CO line 01 rings incoming to the internal modem (QSTU or KSTU port 08).
  - The internal modem rings and auto answers; the modems handshake and establish communications.
  - If the modems send result codes, the PC's screens display, CONNECTXXXX, where XXXX is the data transmission speed set by the communications software.
  - At this time, PC 2 is connected to PDIU-DS (14), as shown by the thick lines above (PDIU-DS 14 is in the command mode). PC 2 can now issue AT commands to PDIU-DS 14.
  - If Digital/PDIU-DS port 04 is the only PDIU port connected to a modem (**Program 20**, LED 03 ON), then the Modem LEDs on all DKTs will light.
- 4) From PC 2's keyboard, type **ATDD10** and press **ENTER** (AT commands must be capital letters); this prompts PDIU-DS (14) to dial and connect to PDIU-DI (10).
- The CONNECT LED on the PDIU-DS (14) will be lit; the Data Call and Modem LEDs on DKT 10 will also be lit.
  - The screens on PC 1 and PC 2 display, CONNECT XXXX, where XXXX is the data transmission speed set by the communication software.
  - At this time, PC 1 and PC 2 are connected, as shown by the thick lines, to exchange data (file transfers, typed messages, etc.).
- 5) To terminate the call: Press the telephone **Data Release** button, and
- a) Type **+++** from PC2 keyboard.
    - The PC screen displays, OK.
  - b) Type **ATH** from the PC keyboard used in step 5a.
    - PC 1's and PC 2's screens both display, NO CARRIER.
    - The DATA and MODEM LEDs on DKT 10 will turn off.

#### 10.86 PC Auto Dial Voice Call Test (see Figure 7-38)

There are many off-the-shelf, IBM/MS-DOS compatible, desktop organizer software packages that provide an auto dialer function. One of these is the terminal resident SideKick. It is used in this section for test explanation purposes only. If you choose another auto dialer software package, the detailed response may be different than that shown here.

##### 1) DIU Programming:

**Program 20:** Port 01. LEDs 01, 02, and 17 ON; all other LEDs OFF.

**Program 39:** Port 01. **Data Call** (56) and **Data Release** (54) buttons are optional; if the PDIU-DI is only used for the PC auto dial application, the **Data Call** and **Data Release** buttons are unnecessary.

- 2) Make sure that the auto dial application software is installed on the PC root directory and that the communication parameters of the PC and application software are set to the same values (in this test example, Sidekick "SKINSTAL" program).

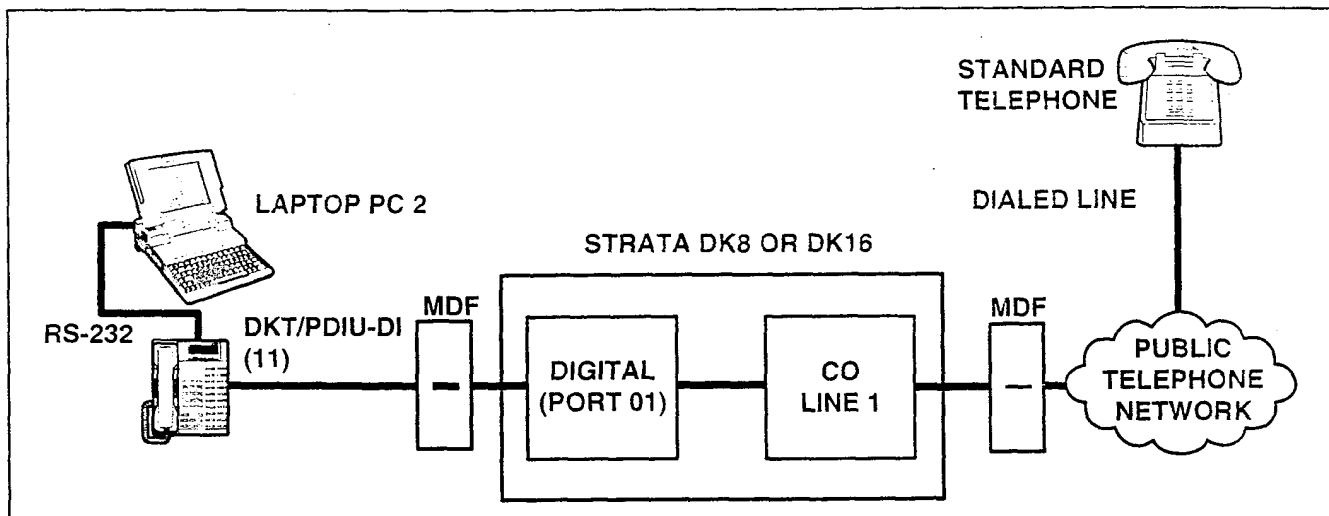


FIGURE 7-38  
DK8 AND DK16 PC AUTO DIAL VOICE CALL TEST

- 3) Make sure that a dialing directory consisting of names and telephone numbers you wish to auto dial is installed within the application software (include the appropriate STRATA CO line access code prefixing each telephone number).
- 4) To auto dial using Sidekick from the PC keyboard:
  - a) Press the **ALT** and **CTRL** keys simultaneously.
    - The PC screen displays the Sidekick menu window.
  - b) Press **F5** twice (Sidekick prompts "search for INITIALS:" to display on the PC's screen).
  - c) Type the initials or name of the person or organization you wish to auto dial.
  - d) Press **ENTER**.
    - Sidekick finds and highlights the desired name/number.
  - e) Press **ENTER** again.
    - DKT/PDIU-DI 11 seizes the appropriate CO line and auto dials the selected telephone number.
    - The LEDs of the DKT's **Data Call** and CO line 01 buttons will be lit (if assigned in **Program 39**).
    - Dial tone, DTMF tones, and ringback or busy tones are audible from the DKT's speaker.
- 5) Take the DKT's handset off-hook at any time after the telephone number is dialed (press the **SPACE** bar to release the **Data Call** button only); or, remain on-hook and use the DKT's speakerphone to talk when the caller party answers (LCD model only, do not press the **SPACE** bar when using the speakerphone).
- 6) To terminate the call anytime:
  - a) If off-hook, press the **SPACE** bar and place the DKT handset on-hook.
  - b) If talking via the speakerphone, press the **SPACE** bar.

## 11 DK16 TWO-CO LINE EXTERNAL AMPLIFIED CONFERENCE

### 11.00 General

**11.01** A customer-supplied two-way amplifier can be installed to amplify two-CO line tandem, DISA, and conference calls. The amplifier will only support one call at a time: Any conference, two CO-line tandem, or DISA calls originated while the amplifier is being used for another call will be unamplified. The amplifier is connected to two designated PEKU or PESU station ports and will automatically be switched into a two-CO line connection established between any CO lines in the system.

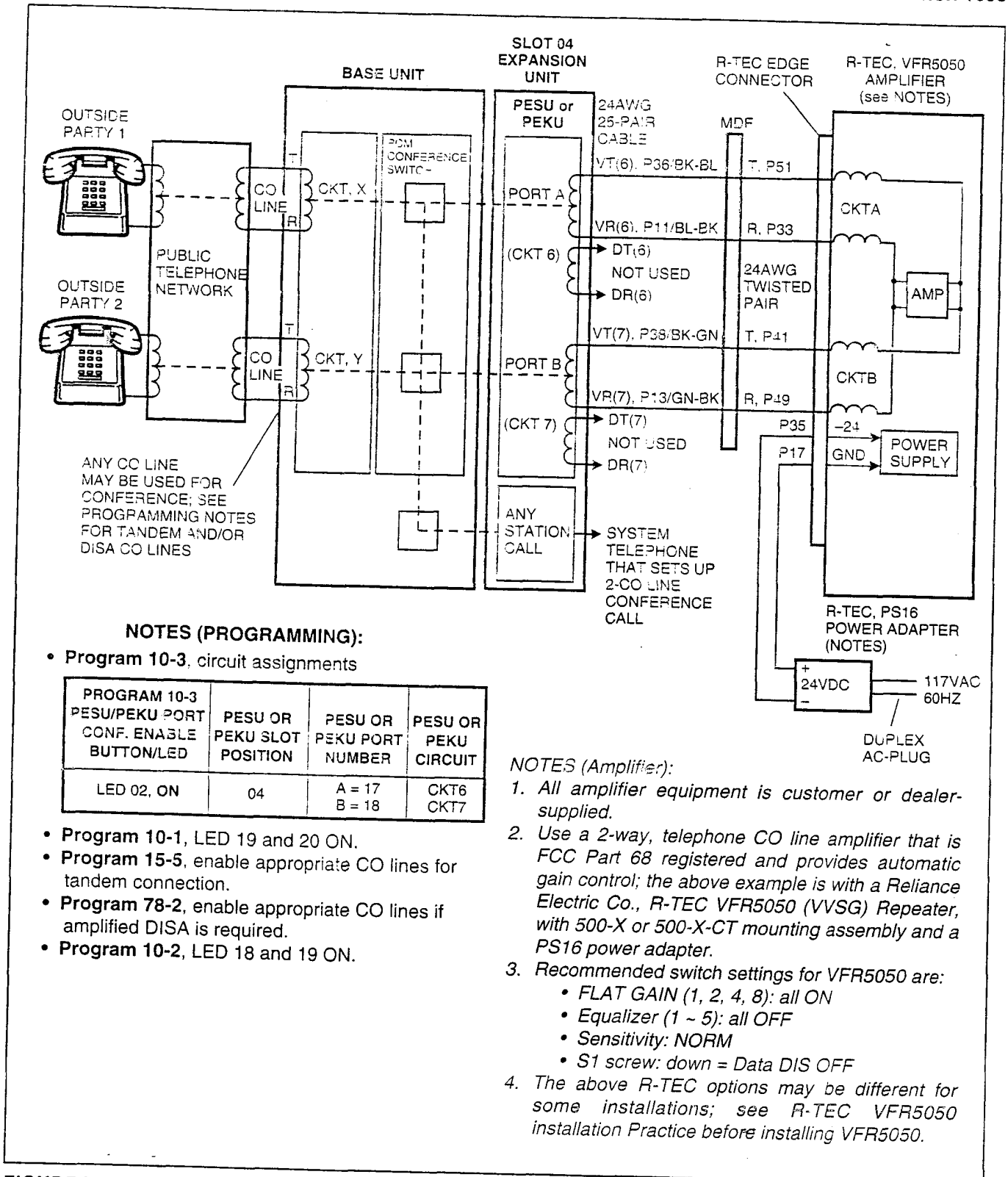


FIGURE 7-39  
DK16 AMPLIFIED TWO-CO LINE CONFERENCE AND/OR AMPLIFIED DISA FUNCTIONAL WIRING  
DIAGRAM

**INSTALLATION-PERIPHERALS**  
**SECTION 100-816-207**  
**MARCH 1993**

**11.02 Amplified Talk Path.** Figure 7-39 provides a functional diagram of a two-CO line amplified conference connection (an R-TEC VFR5050 amplifier is used here). The talk path for the connection is as follows: outside party 1—public telephone network—CO, CKTX—STRATA DK16—PEKU, port A—into AMP, CKTA—Out AMP, CKT B—PEKU, port B—STRATA DK16—CO, CKTY—public telephone network—outside party 2. This path is two-way so when outside party 2 talks, the talk level is amplified in the reverse direction.

**NOTE:**

*Only the outside party 1 talk path is amplified to/from a system telephone when it is connected into a two-CO line conference.*

**11.03 Amplifier Requirements.**

- Customer-supplied.
- Must be FCC-registered, Part 68, and provide automatic gain control.
- Requires two PEKU or PESU station ports (17 and 18).
- Refer to the amplifier manufacturer's installation documentation for amplifier grounding instructions.

**11.04 Installation.** Connect a two-way amplifier to the STRATA DK16 system in accordance with the following steps (see Figures 7-39 and 8-27).

- 1) At the main distribution frame (MDF), connect the voice pair (VT, VR, port A) of circuit 6 on the designated PEKU or PESU PCB to one input of the customer-supplied two-way amplifier. In the example in Figure 7-39, this is CKTA (Central Office Side A) of the VFR5050.
- 2) At the MDF, connect the voice pair (VT, VR, port B) of circuit 7 on the designated PESU or PEKU PCB to the other input of the amplifier. In the Figure 7-39 example, this is CKTB (subscriber side B) of VFR5050.
- 3) Plug the amplifier's power cord into the 117 VAC (standard) wall outlet.
- 4) Set the gain and other amplifier parameters options per the amplifier manufacturer's installation documentation.
- 5) Program the STRATA DK16 system as follows:
  - **Program 10-3:** Enables the appropriate PEKU or PESU PCB ports for amplifier connection. Only enable the ports that will be connected with the amplifier(s).
  - **Program 15-5:** Enables appropriate CC lines for tandem connection.
  - **Program 10-1:** LEDs 19 and 20 must be ON.
  - **Program 10-2:** LED 18 and 19 must be ON.

# **Strata**<sup>®</sup> DK8 & DK16

## **INSTALLATION**

### **CHAPTER EIGHT WIRING DIAGRAMS**

**TABLE OF CONTENTS**

PARAGRAPH	SUBJECT	PAGE
1	GENERAL .....	8-1
2	WIRING DIAGRAMS .....	8-1
2.10	Station Wiring Diagrams .....	8-1
2.20	CO Line Wiring Diagrams .....	8-1
2.30	PIOU and PIOUS Wiring Diagrams .....	8-1

**FIGURE LIST**

FIGURE	TITLE	PAGE
8-1	SECONDARY PROTECTOR DIAGRAM .....	8-5
8-2	DK8 MDF WIRING TO KSU AMPHENOL STATION AND RELAY CONNECTIONS .....	8-7
8-3	DK8 MDF WIRING TO CO LINES (KSU AND QCDU) .....	8-8
8-4	DK8/DK16 MDF WIRING DDCB AND DOOR LOCK CONTROL .....	8-9
8-5	DK8 QSTU/DK16 KSTU STATION/MDF CROSS CONNECT RECORD .....	8-10
8-6	DK8 AND DK16 CO LINE RECORD .....	8-10
8-7	DK8 QSMU TTY/SMDR WIRING .....	8-11
8-8	DK16 MDF WIRING/BASE UNIT P5 AMPHENOL STATION AND RELAY CONNECTIONS .....	8-12
8-9	DK16 MDF WIRING/CO LINES TO BASE UNIT .....	8-13
8-10	DK16 MDF WIRING FOR DIGITAL TELEPHONES (DKTS) AND DIGITAL DSS CONSOLE (DDSS) TO PDKU .....	8-14
8-11	DK16 MDF WIRING FOR DIGITAL TELEPHONES (DKTS) WITH PDIU-DI/PDIU-DI2 AND PDIU-DS TO PDKU, KCDU, OR BASE UNIT .....	8-15
8-12	DK8 OR DK16 PDKU, KCDU, DK8 KSU, OR DK16 BASE KSU DIGITAL STATION/MDF CROSS CONNECT RECORD .....	8-16
8-13	DK16 MDF WIRING/ELECTRONIC TELEPHONE TO PEKU .....	8-17
8-14	DK16 MDF WIRING/HDSS CONSOLE AND ASSOCIATED ELECTRONIC TELEPHONE WIRING TO PEKU .....	8-18
8-15	DK16 PEKU BACKGROUND MUSIC CONNECTION .....	8-19
8-16	DK16 PEKU STATION/MDF CROSS CONNECT RECORD .....	8-20
8-17	DK16 MDF WIRING/STANDARD TELEPHONE, VOICE MAIL TO PSTU .....	8-21
8-18	DK16 PSTU STATION/MDF CROSS CONNECT RECORD .....	8-22
8-19	DK16 PESU CIRCUIT CARD WIRING DIAGRAM .....	8-23
8-20	DK16 PESU STATION/MDF CROSS CONNECT RECORD .....	8-24
8-21	DK16 MDF WIRING/CO LINES TO PCOU .....	8-25
8-22	DK16 MDF WIRING/CO LINES AND DIGITAL TELEPHONES TO KCDU .....	8-26
8-23	DK16 MDF WIRING/PIOU PERIPHERALS (25-PAIR) .....	8-27
8-24	DK16 PIOUS/TTY AND SMDR WIRING .....	8-28
8-25	DK16 PIOUS PAGE/RELAY/ALARM CONNECTIONS .....	8-29
8-26	DK16 PIOU SMDR/TTY OPTIONS AND WIRING .....	8-30
8-27	DK16 MDF WIRING/AMPLIFIED TWO-CO LINE CONFERENCE .....	8-31
8-28	DK16 EXTERNAL POWER FOR DIGITAL TELEPHONE CONNECTION .....	8-32



**INSTALLATION-WIRING DIAGRAMS**  
**SECTION 100-816-208**  
**MARCH 1993**

**TABLE LIST**

<b>TABLE</b>	<b>TITLE</b>	<b>PAGE</b>
<b>8-A</b>	FCC REGISTRATION NUMBERS STRATA DK8 AND DK16 .....	<b>8-1</b>
<b>8-B</b>	STATION LOOP REQUIREMENTS .....	<b>8-2</b>
<b>8-C</b>	NETWORK REQUIREMENTS .....	<b>8-3</b>
<b>8-D</b>	DIGITAL TELEPHONE/DIU/DDSS CONSOLE. ADM/LOOP LIMITS .....	<b>8-4</b>

## 1 GENERAL

1.00 This chapter contains point-to-point wiring diagrams for connection of telephones, lines, peripheral equipment, and power supply to the DK systems. Wiring diagrams are divided into groups according to the PCB or unit which provides the interface for, or controls the operation of, the associated equipment.

## 2 WIRING DIAGRAMS

2.01 The following paragraphs list and identify the wiring diagrams provided in this chapter.

### 2.10 Station Wiring Diagrams

- Figure 8-1 — Secondary Protector Diagram
- Figure 8-2 — DK8 MDF Wiring to KSU Amphenol Station and Relay Connections
- Figure 8-3 — DK8 MDF Wiring to CO Lines (KSU and QCDU)
- Figure 8-4 — DK8/DK16 MDF Wiring DDCB and Door Lock Control
- Figure 8-6 — DK8 and DK16 CO Line Record
- Figure 8-7 — DK8 QSMU TTY/SMDR Wiring
- Figure 8-8 — DK16 MDF Wiring/Base Unit P5 Amphenol Station and Relay Connections
- Figure 8-9 — DK16 MDF Wiring/CO Lines to Base Unit
- Figure 8-10 — DK16 MDF Wiring for Digital Telephones (DKTS) and Digital DSS Console (DDSS) to PDKU
- Figure 8-11 — DK16 MDF Wiring for Digital Telephones (DKTS) with PDIU-DI/PDIU-DI2 and PDIU-DS to PDKU, KCDU, or Base Unit
- Figure 8-12 — DK8 or DK16 PDKU, KCDU, DK8 KSU or DK16 Base KSU Digital Station/MDF Cross Connect Record

- Figure 8-13 — DK16 MDF Wiring/Electronic Telephone to PEKU
- Figure 8-14 — DK16 MDF Wiring/HDSS Console and Associated Electronic Telephone Wiring to PEKU
- Figure 8-15 — DK16 PEKU Background Music Connection
- Figure 8-16 — DK16 PEKU Station/MDF Cross Connect Record
- Figure 8-17 — DK16 MDF Wiring/Standard Telephone, Voice Mail to PSTU
- Figure 8-18 — DK16 PSTU Station/MDF Cross Connect Record
- Figure 8-21 — DK16 MDF Wiring/CO Lines to PCOU
- Figure 8-27 — DK16 MDF Wiring/Amplified Two-CO Line Conference
- Figure 8-28 — DK16 External Power for Digital Telephone Connection

### 2.20 CO Line Wiring Diagrams

- Figure 8-5 — DK8 QSTU/DK16 KSTU Station/MDF Cross Connect Record
- Figure 8-19 — DK16 PESU Circuit Card Wiring Diagram
- Figure 8-20 — DK16 PESU Station/MDF Cross Connect Record

### 2.30 PIOUS and PIOUS Wiring Diagrams

- Figure 8-22 — DK16 MDF Wiring/CO Lines and Digital Telephones to KCDU
- Figure 8-23 — DK16 MDF Wiring/PIOUS Peripherals (25-Pair)
- Figure 8-24 — DK16 PIOUS/TTY and SMDR Wiring
- Figure 8-25 — DK16 PIOUS Page/Relay/Alarm Connections
- Figure 8-26 — DK16 PIOUS SMDR/TTY Options and Wiring

**TABLE 8-A**  
**FCC REGISTRATION NUMBERS STRATA DK8 AND DK16**

System	Manufacture Country	Key System	Hybrid System
DK16	Made in Singapore	CJ6 SNG-73672-KF-E	CJ6 SNG-73673-MF-E
DK8	Made in Malaysia	CJ6 MLA-74479-KF-E	CJ6 MLA-74478-MF-E

**TABLE 8-B  
STATION LOOP REQUIREMENTS**

Device Description	Max Loop Resistance (Including Device)	Max Distance from KSU to Device	Number of Wire Pairs <sup>1</sup>
Electronic <sup>†</sup> telephone	40 ohms	1000 ft. (303 m)	2-pair. EKTs which receive OCA calls need 3-pair.
HDSS console	20 ohms	500 ft. (152 m)	
Standard telephones, voice mail, auto attendant, etc.	300 ohms	Approx. 3000 ft. (909 m) with 150 ohm device. See manufacturer's product specifications for exact resistance of device.	1-pair
Digital telephone or DDCB <sup>3</sup>	40 ohms	1000 ft. (303 m)	1-pair <sup>4</sup>
DDSS console	40 ohms	1000 ft. (303 m)	1-pair <sup>4</sup>
PDIU-DI PDIU-DI2	40 ohms	1000 ft. (303 m)	Shares digital telephone wire-pair. <sup>4</sup>
PDIU-DS	40 ohms	1000 ft. (303 m)	1-pair <sup>4</sup>
ADM	40 ohms	1000 ft. (303 m)	Shares digital telephone wire-pair. <sup>4</sup>

**NOTES:**

1. Use 24 AWG twisted pairs.
2. PESU circuits 3 and 4 are not used.
3. DDCB can connect only to Circuit 5 of the DK16 Base Unit or Circuit 1 of the PDKU or KCDU.
4. Two-pair, larger wire, or local telephone power supply is required to achieve maximum range, see Table 8-D.

**TABLE 8-C  
NETWORK REQUIREMENTS**

TOSHIBA Printed Circuit Board or Interface	Facility Interface Code	Network Jack	Ringer Equivalence
QCDU/KCDU/PCOU/PCOU2 (Loop Start Line)	02LS2	RJ14C	0.2B
DK8 KSU DK16 Base KSU (Loop Slant Line)	02LS2	RJ11C	0.2B
QSTU/KSTU/PESU*/PSTU/ PSTU2 (Off-premises Station)	0L13A	RJ21X	N/A

*\*Circuits 1 and 2*

**TABLE 8-D**  
**DIGITAL TELEPHONE/DIU/DDSS CONSOLE/ADM/LOOP LIMITS**

MODE	QPSU/KPSU or Battery Backup <sup>1</sup>	Maximum line length (24 AWG)		
		1 Pair	2 Pair	1 Pair plus external power <sup>3</sup>
DKT Ringing (Volume Max)	QPSU/KPSU	1000 ft (303 m)	1000 ft (303 m)	1000 ft (303 m)
	Battery Backup	675 ft (204 m)	1000 ft (303 m)	1000 ft (303 m)
DKT with DVSU (OCA)	QPSU/KPSU	1000 ft (303 m)	1000 ft (303 m)	1000 ft (303 m)
	Battery Backup	495 ft (150 m)	1000 ft (303 m)	1000 ft (303 m)
DKT with HHEU or Carbon Handset	QPSU/KPSU	1000 ft (303 m)	1000 ft (303 m)	1000 ft (303 m)
	Battery Backup	330 ft (100 m)	1000 ft (303 m)	1000 ft (303 m)
DKT with PDIU-DI/ PDIU-DI2	QPSU/KPSU	495 ft (150 m)	1000 ft (303 m)	1000 ft (303 m)
	Battery Backup	165 ft (50 m)	675 ft (200 m)	1000 ft (303 m)
PDIU-DS	QPSU/KPSU	1000 ft (303 m)	1000 ft (303 m)	1000 ft (303 m)
	Battery Backup	675 ft (204 m)	1000 ft (303 m)	1000 ft (303 m)
DKT with HHEU and PDIU-DI/PDIU-DI2	QPSU/KPSU	495 ft (150 m)	1000 ft (303 m)	1000 ft (303 m)
	Battery Backup	33 ft (10 m)	330 ft (100 m)	1000 ft (303 m)
DDSS2060A	QPSU/KPSU	1000 ft (303 m)	1000 ft (303 m)	1000 ft (303 m)
	Battery Backup	500 ft (151 m)	1000 ft (303 m)	1000 ft (303 m)
DDCB	QPSU/KPSU	1000 ft (303 m)	1000 ft (303 m)	1000 ft (303 m)
	Battery Backup	500 ft (151 m)	1000 ft (303 m)	1000 ft (303 m)
DKT with DVSU and HHEU	QPSU/KPSU	1000 ft (303 m)	1000 ft (303 m)	1000 ft (303 m)
	Battery Backup	165 ft (50 m)	1000 ft (303 m)	1000 ft (303 m)
DKT with ADM	QPSU/KPSU	675 ft (204 m)	1000 ft (303 m)	1000 ft (303 m)
	Battery Backup	165 ft (50 m)	1000 ft (303 m)	1000 ft (303 m)

**NOTES:**

1. Battery backup applies to instances when the system is being powered by batteries exclusively.
2. Digital telephones and other digital devices can operate at maximum lengths with two pair wiring or an external power source.
3. See **Figure 8-28** for external power wiring.
4. Digital cable runs must not have the following:
  - Cable splits (single or double)
  - Cable bridges (of any length)
  - High resistance or faulty cable splices

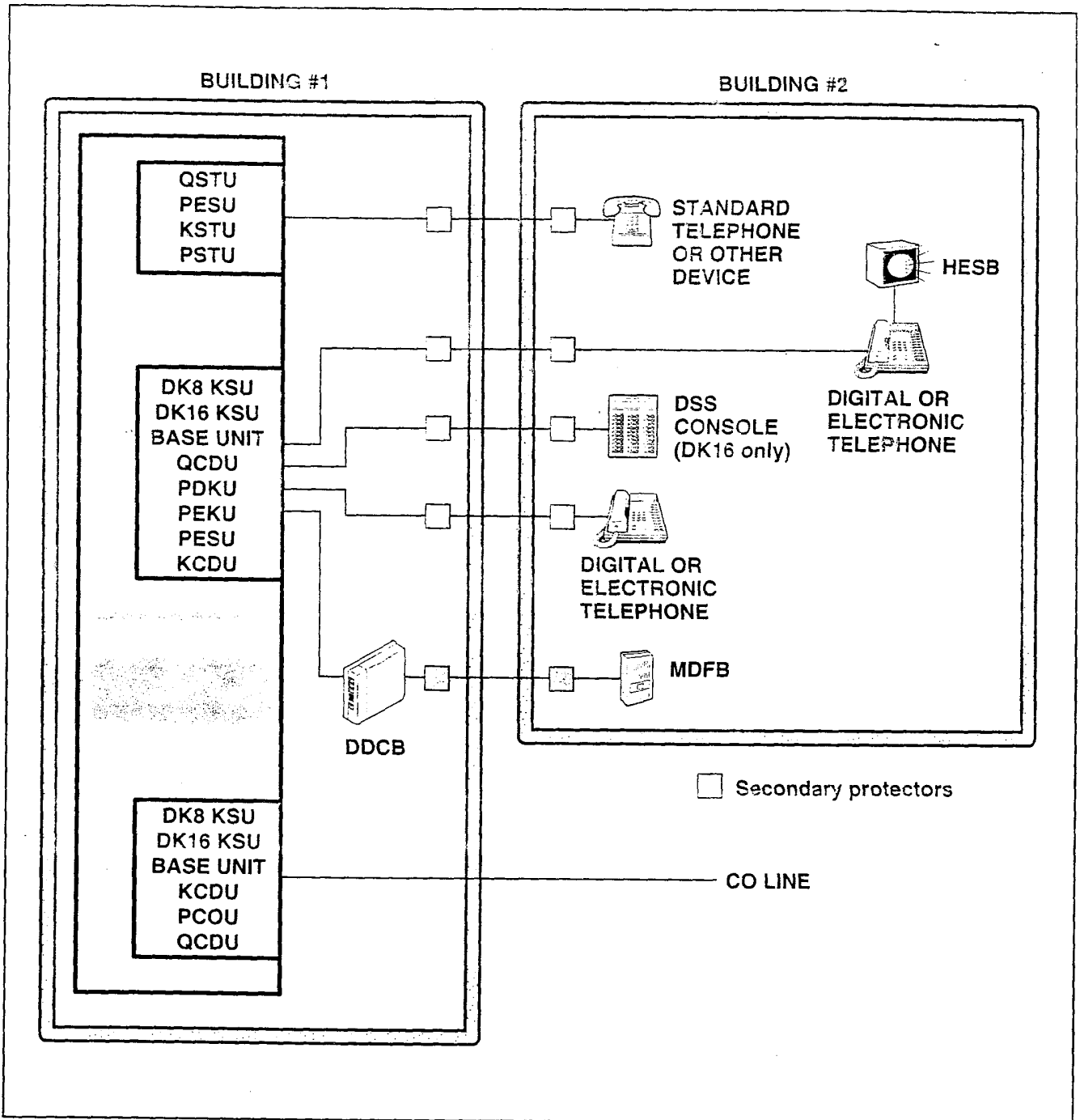


FIGURE 8-1  
SECONDARY PROTECTOR DIAGRAM

**IMPORTANT!**

To protect against transient voltages and currents, secondary protectors must be installed if there is outside wiring (Figure 8-1). These protectors, which contain fast semiconductors in addition to fuses, shall comply with the requirements for secondary protectors for communication circuits, UL 497A. As of October 1, 1990, the following manufacturers offer secondary protectors that are UL listed.

**INSTALLATION-WIRING DIAGRAMS**  
**SECTION 100-816-208**  
**MARCH 1993**

1. ***Certron Corp; Anaheim, California 92807***
  - ***Secondary protector: Model 08450.***
  
2. ***Curtis Mfg. Co. Inc; Jaffrey, New Hampshire 03452***
  - ***Secondary protector: Model Diamond Chip. For indoor use on the protected side of the telephone circuit only.***
  
3. ***Oneac Corp; Libertyville, Illinois 60048***
  - ***Secondary protector: Model OnLine 614+ and OnLine DG/S. For indoor use on the protected side of primary telephone protector only.***
  
4. ***Siemon Co.; Watertown, Connecticut 06795***
  - ***Secondary protector for communication circuits: Model PM-2305. Intended for use with Listed Siemon 66M1 Block: Models PG-04, -25, -50, or PK-04 ground kit and Listed Type 1 enclosure. For use on the protected side of a Listed Primary Telecommunications Protector for indoor use only.***
  
5. ***Simplex Time Recorder Co.; Gardner, Massachusetts 01440***
  - ***Isolated loop circuit protectors: Models 2081-9027 and 2081-9028. Intended for use between data communication equipment or signal lines of building system equipment.***

***Install and test the secondary protectors per the installation instructions of the applicable manufacturer.***

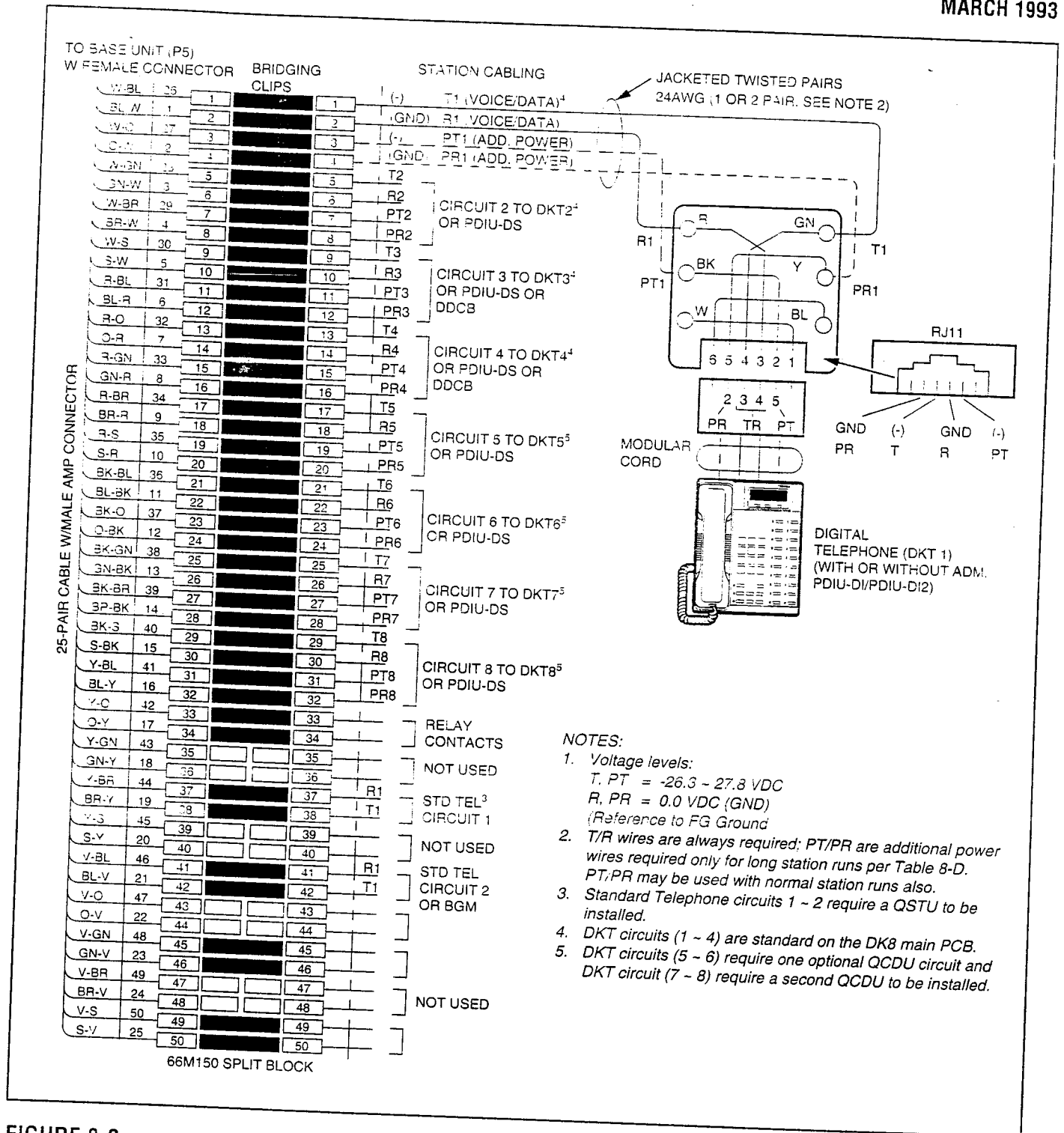
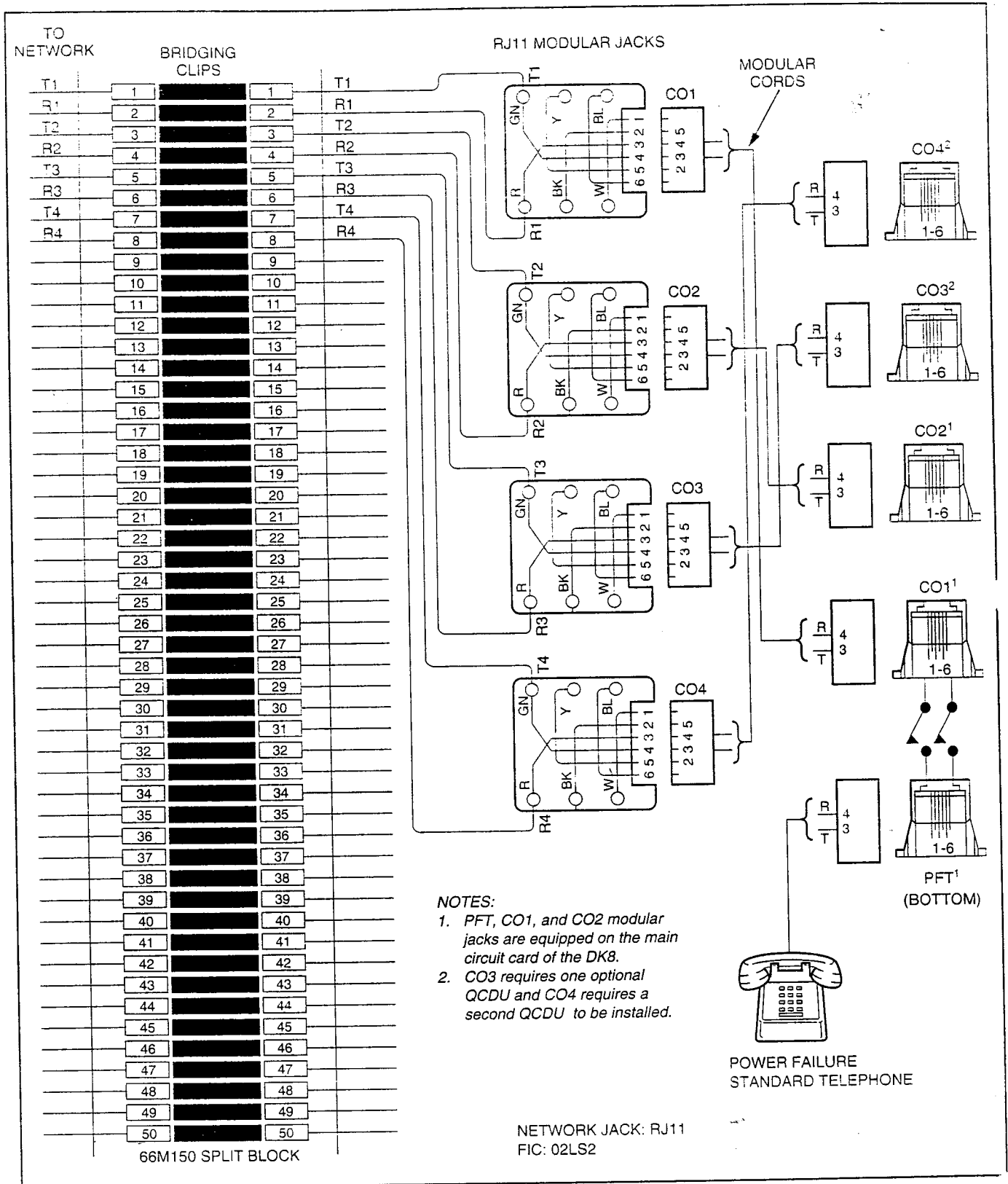


FIGURE 8-2  
DK8 MDF WIRING TO KSU AMPHENOL STATION AND RELAY CONNECTIONS



**INSTALLATION-WIRING DIAGRAMS**  
**SECTION 100-316-208**  
**MARCH 1993**



**FIGURE 8-3**  
**DK8 MDF WIRING TO CO LINES (KSU AND QCDU)**

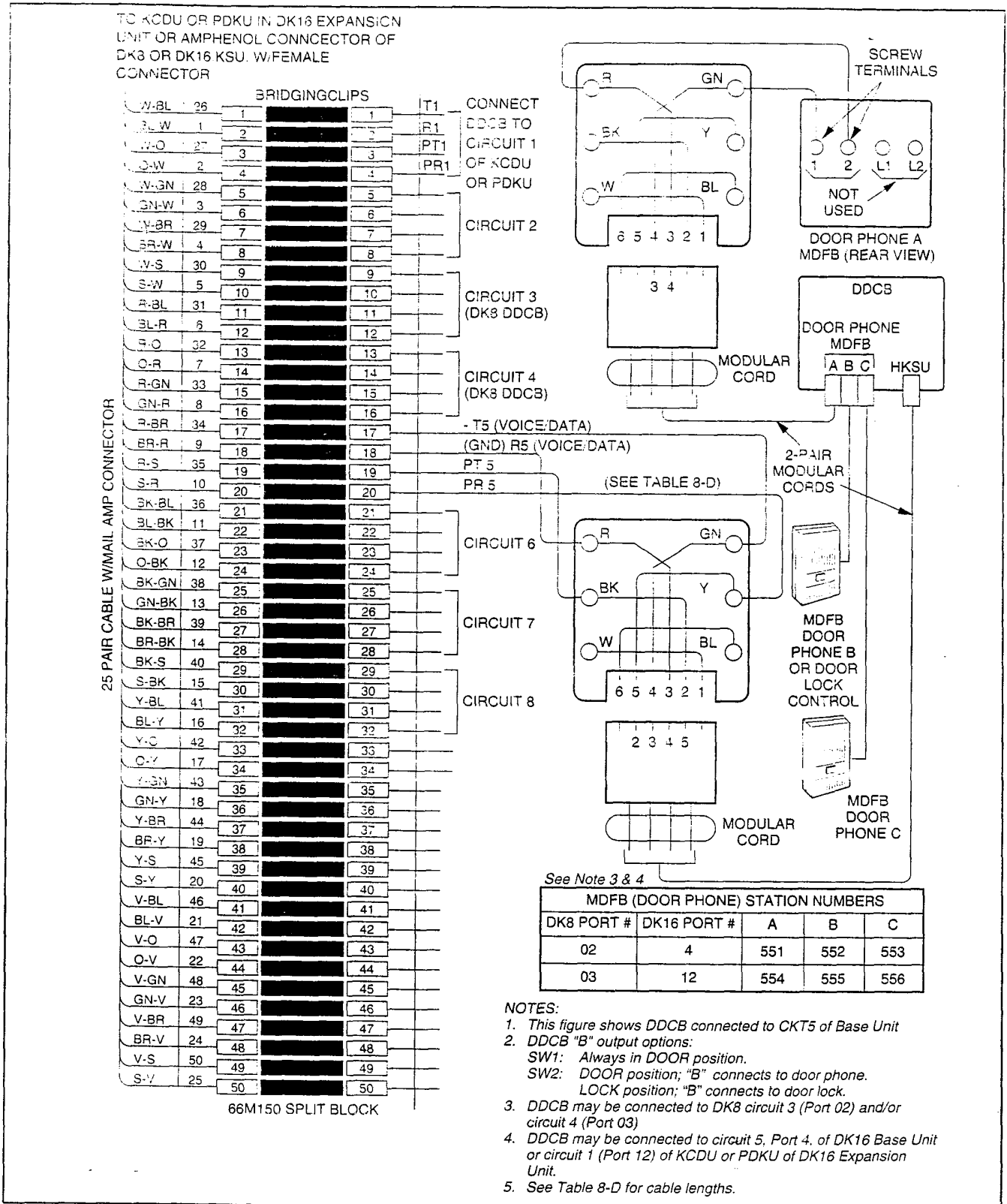


FIGURE 8-4  
DK8/DK16 MDF WIRING DDCB AND DOOR LOCK CONTROL

**INSTALLATION-WIRING DIAGRAMS**  
**SECTION 100-816-208**  
**MARCH 1993**

MDF BLOCK NO. \_\_\_\_\_ KSTU/QSTU

COLOR CODE	DESIGNATION	CKT NUMBER	PORT NUMBER	INTERCOM NUMBER	STANDARD TELEPHONE/ DEVICE LOCATION
Y-BR	T	1			
BR-Y	R				
Y-S	NOT USED				
S-Y	NOT USED				
V-BL	T	2 <sup>3</sup>			
BL-V	R				
V-O	NOT USED				
O-V	NOT USED				
V-GN	T	3 <sup>1</sup>			
GN-V	R				
V-BR	NOT USED				
BR-V	NOT USED				
V-S	T	4 <sup>1,2</sup>			
S-V	R				
	NOT USED				
	NOT USED				

**NOTE:**

1. Circuit 3 and 4 are available on DK16 KSTU only.
2. Circuit 4 can support a Background Music (BGM) source, KSTU or PSTU, DK16 only.
3. Circuit 2 can support a Background Music (BGM) source, QSTU Port 19, DK8 only.

**FIGURE 8-5**  
**DK8 QSTU/DK16 KSTU STATION/MDF CROSS CONNECT RECORD**

CO LINE CROSS-CONNECT RECORD

MDF PAIR NUMBERS RJ11C/RJ14C	CO LINE NUMBER	BASE UNIT (KCDU/PCOU)
RJ11C	1	DK8 KSU DK16 BASE UNIT, FIXED SLOT 02
RJ11C	2	
RJ11C	3	
RJ11C	4	
RJ14C	5	KCDU/PCOU SLOT 04, 05 (DK16 ONLY)
	6	
	7	
RJ14C	8	

**FIGURE 8-6**  
**DK8 AND DK16 CO LINE RECORD**

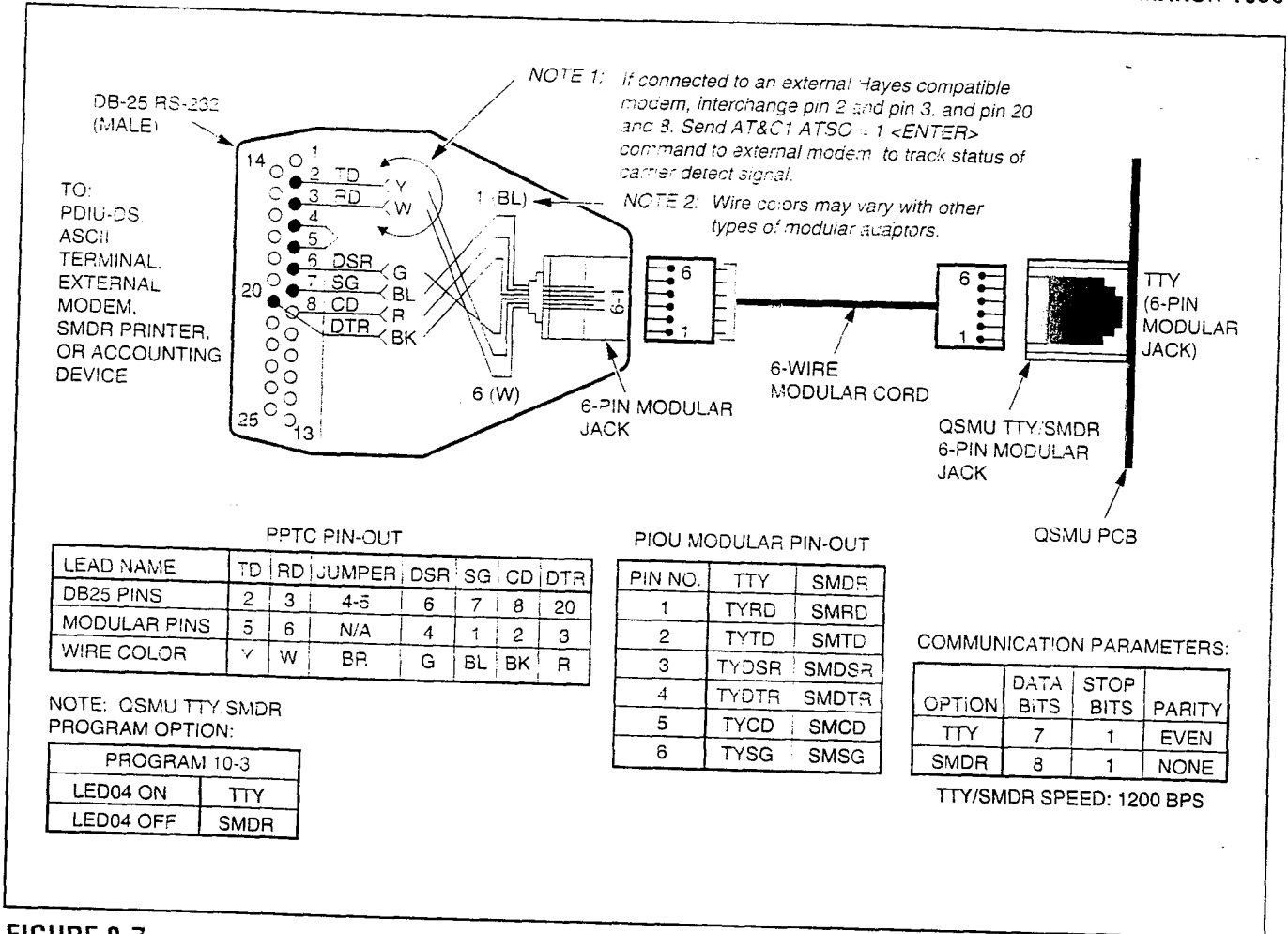
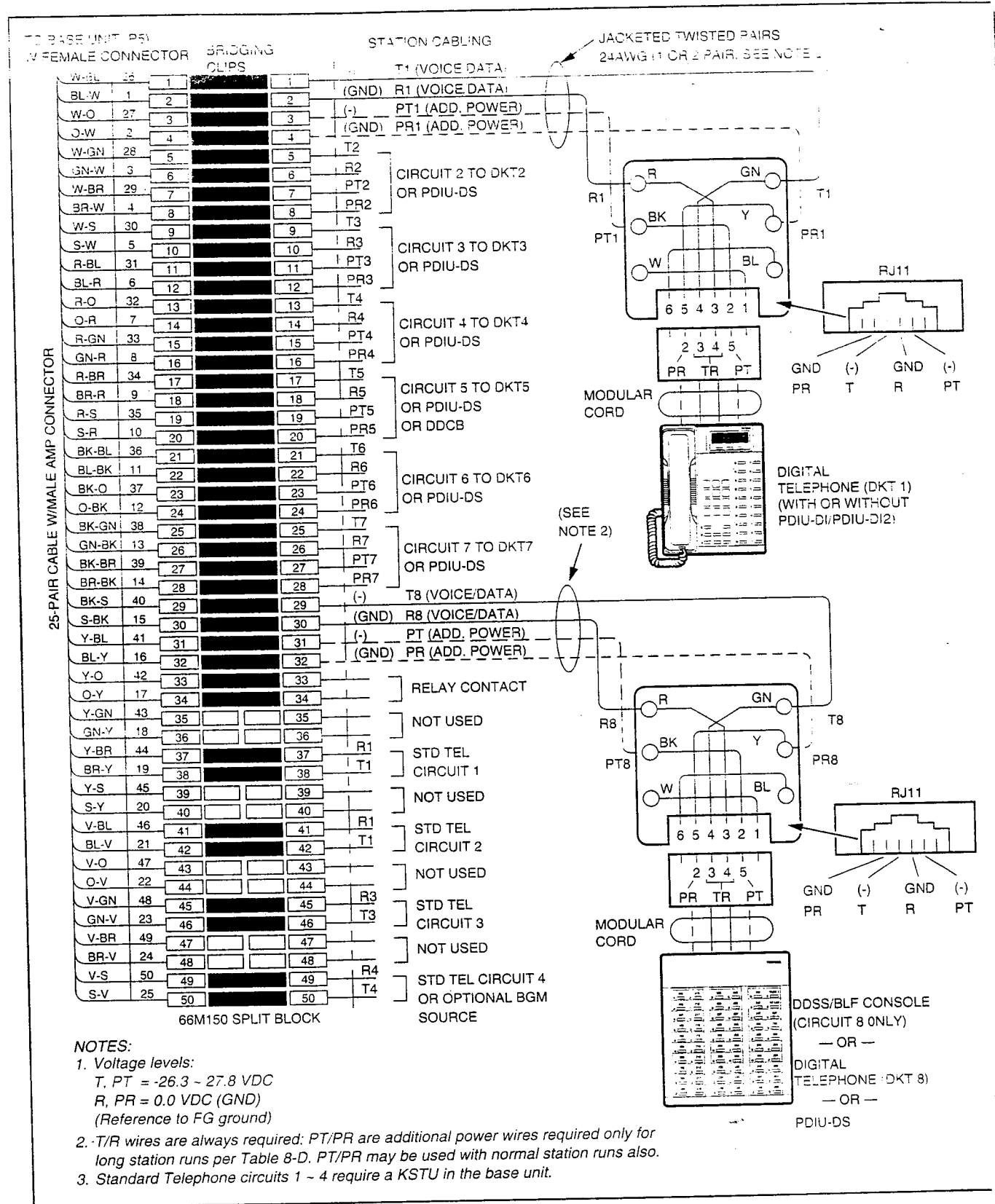


FIGURE 8-7  
DK8 QSMU TTY/SMDR WIRING

**INSTALLATION-WIRING DIAGRAMS**  
**SECTION 100-816-208**  
**MARCH 1993**



**FIGURE 8-8**  
**DK16 MDF WIRING/BASE UNIT P5 AMPHENOL STATION AND RELAY CONNECTIONS**

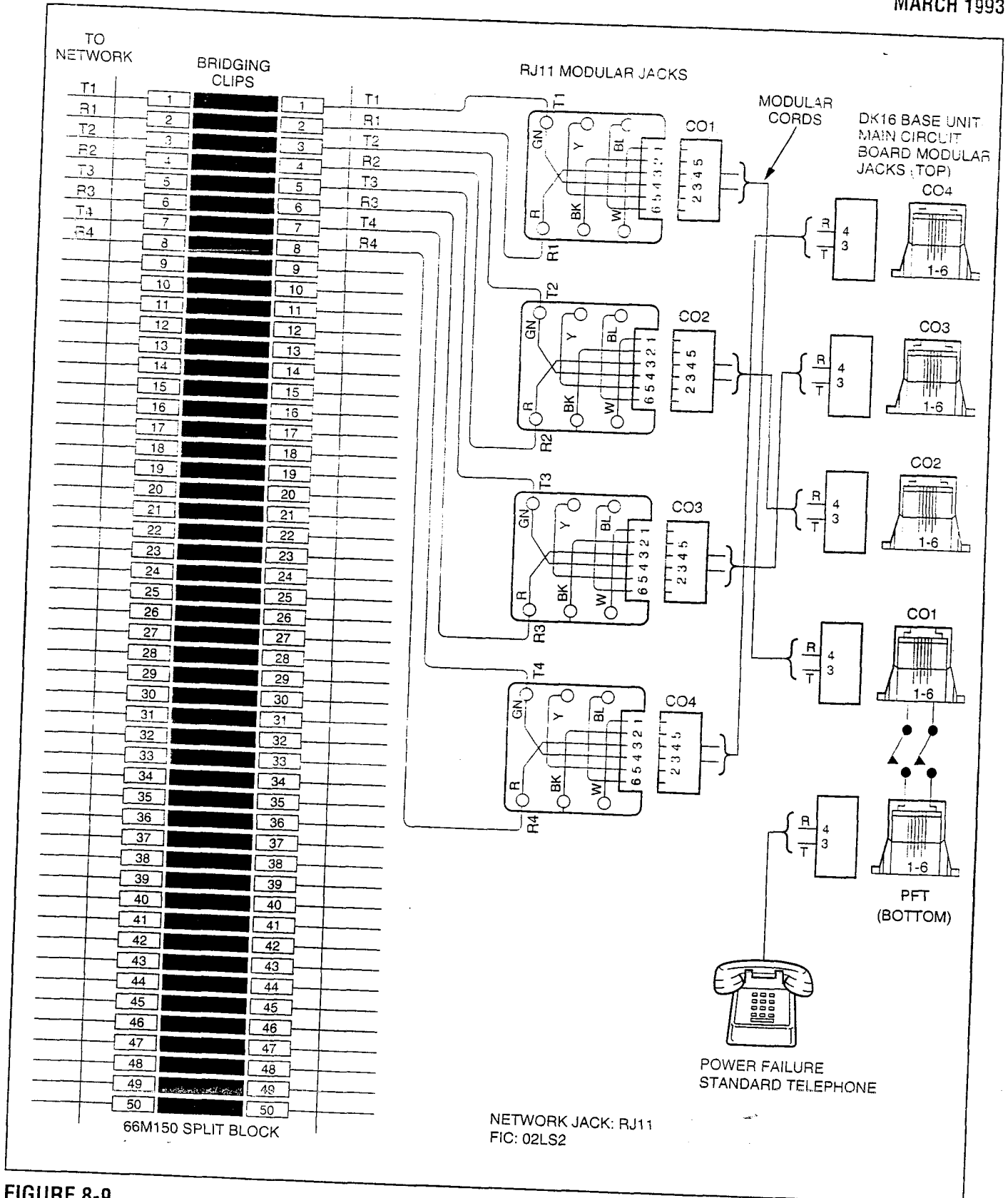
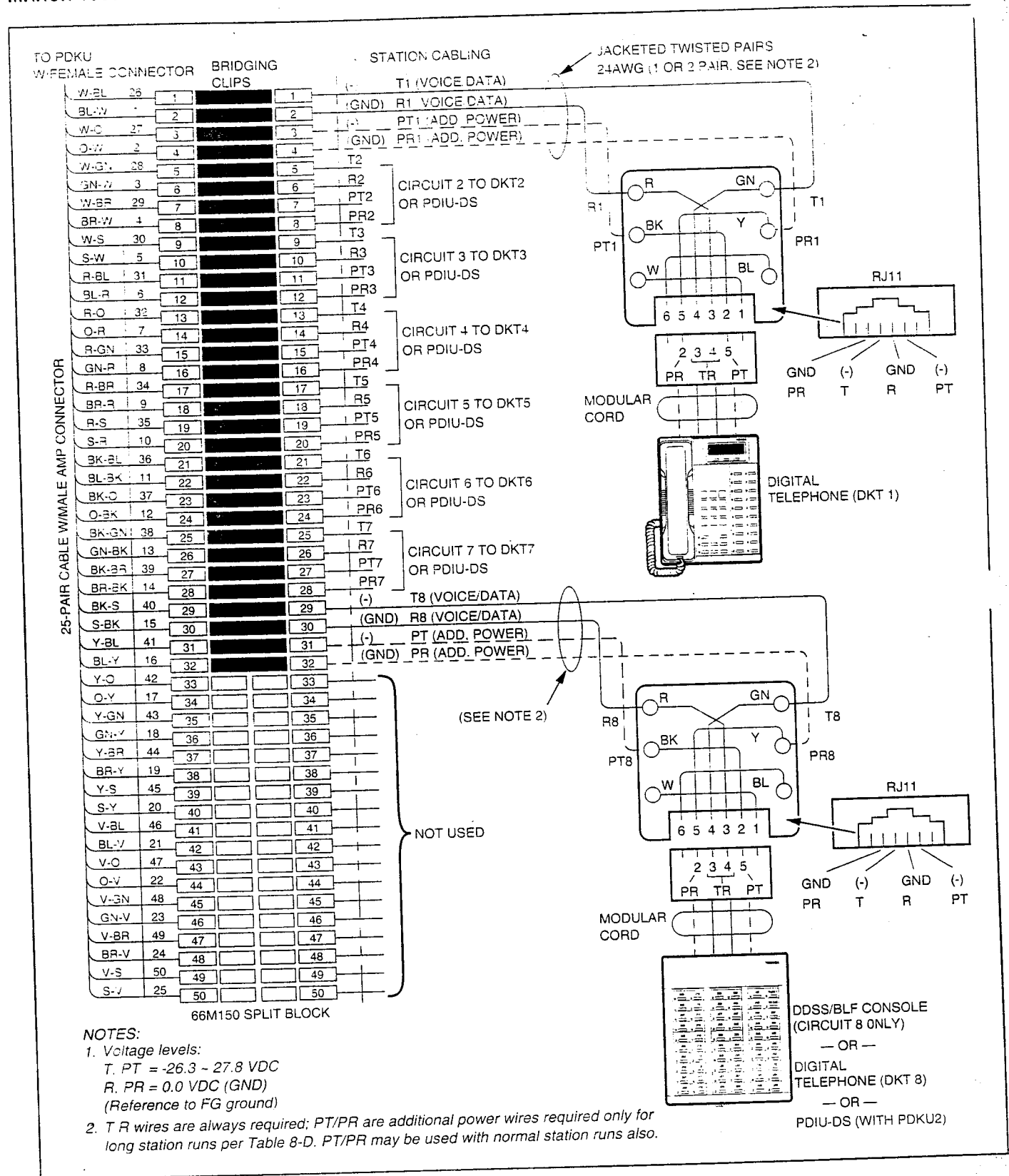
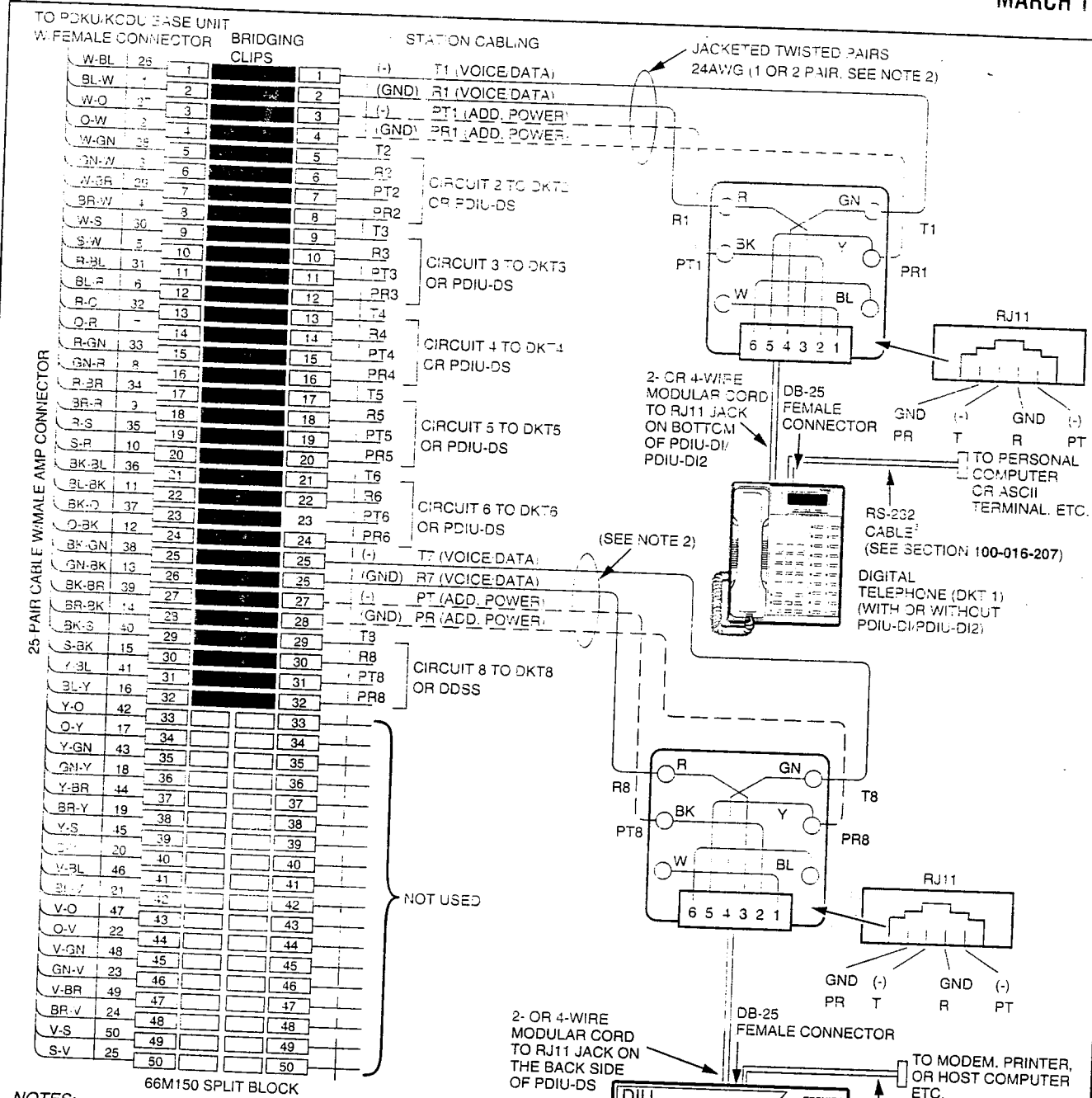


FIGURE 8-9  
DK16 MDF WIRING/CO LINES TO BASE UNIT

**INSTALLATION-WIRING DIAGRAMS**  
**SECTION 100-816-208**  
**MARCH 1993**



**FIGURE 8-10**  
**DK16 MDF WIRING FOR DIGITAL TELEPHONES (DKTS) AND DIGITAL DSS CONSOLE (DDSS) TO PDKU**



NOTES:

- Voltage levels:  
T, PT = -26.3 - 27.8 VDC  
R, PR = 0.0 VDC (GND)  
(Reference to SG ground)
- T/R wires are always required; PT/PR are additional power wires required only for long station runs or when operating on reserve power per Table 8-D. PT/PR may be used with normal station runs also. RS-232 cable length is max 50 ft with 24 AWG wire.
- DIUs can be connected to circuits 1 - 7 with PDKU1; all Base Unit, KCDU, and PDKU2 digital circuits support DIUs.
- Expansion Unit slots 04 and 05 only can support DIU.
- KCDU provides circuits 1 - 4 only.

FIGURE 8-11  
DK16 MDF WIRING FOR DIGITAL TELEPHONES (DKTS) WITH PDIU-DI/PDIU-DI2 AND PDIU-DS TO PDKU, KCDU, OR BASE UNIT



**INSTALLATION-WIRING DIAGRAMS**  
**SECTION 100-816-208**  
**MARCH 1993**

MDF BLOCK NO. \_\_\_\_\_ SLOT NO. \_\_\_\_\_

COLOR CODE	DESIGNATION	CKT NUMBER	PORT NUMBER	INTERCOM NUMBER	DIGITAL TELEPHONE/ DEVICE LOCATION
W-BI	T	1			6
BI-W	R				
W-O	PWR T				
O-W	PWR R				
W-G	T	2			
G-W	R				
W-Br	PWR T				
Br-W	PWR R				
W-S	T	3			7
S-W	R				
R-BI	PWR T				
BI-R	PWR R				
R-O	T	4			7
O-R	R				
R-G	PWR T				
G-R	PWR R				
R-Br	T	5			6
Br-R	R				
R-S	PWR T				
S-R	PWR R				
Bk-BI	T	6			
BI-Bk	R				
Bk-O	PWR T				
O-Bk	PWR R				
Bk-G	T	7			
G-Bk	R				
Bk-Br	PWR T				
Br-Bk	PWR R				
Bk-S	T	8			-
S-Bk	R				
Y-BI	PWR T				
BI-Y	PWR R				

**NOTES:**

1. Indicate if PDIU-DS, digital telephone (with or without PDIU-DI/PDIU-DI2 or ADM) or DDSS console (number 1 or 2) is connected.
2. PDIU-DS and PDIU-DI/PDIU-DI2 can be connected to circuits 1 ~ 7 only on PDKU1; all Base Unit, KCDU, and PDKU2 digital circuits support DIUs.
3. Expansion Unit slots 04 and 05 only can support DIUs.
4. For KCDU, only ckt number 1 thru 4 apply.
5. Make copies as necessary.
6. PDKU and KCDU Circuit 1 can support DDCB. Base Unit Circuit 5 can support DDCB.
7. DK8 circuit 3 and or circuit 4 can support DDCB.

**FIGURE 8-12**  
**DK8 OR DK16 PDKU, KCDU, DK8 KSU OR DK16 BASE KSU DIGITAL STATION/MDF**  
**CROSS CONNECT RECORD**

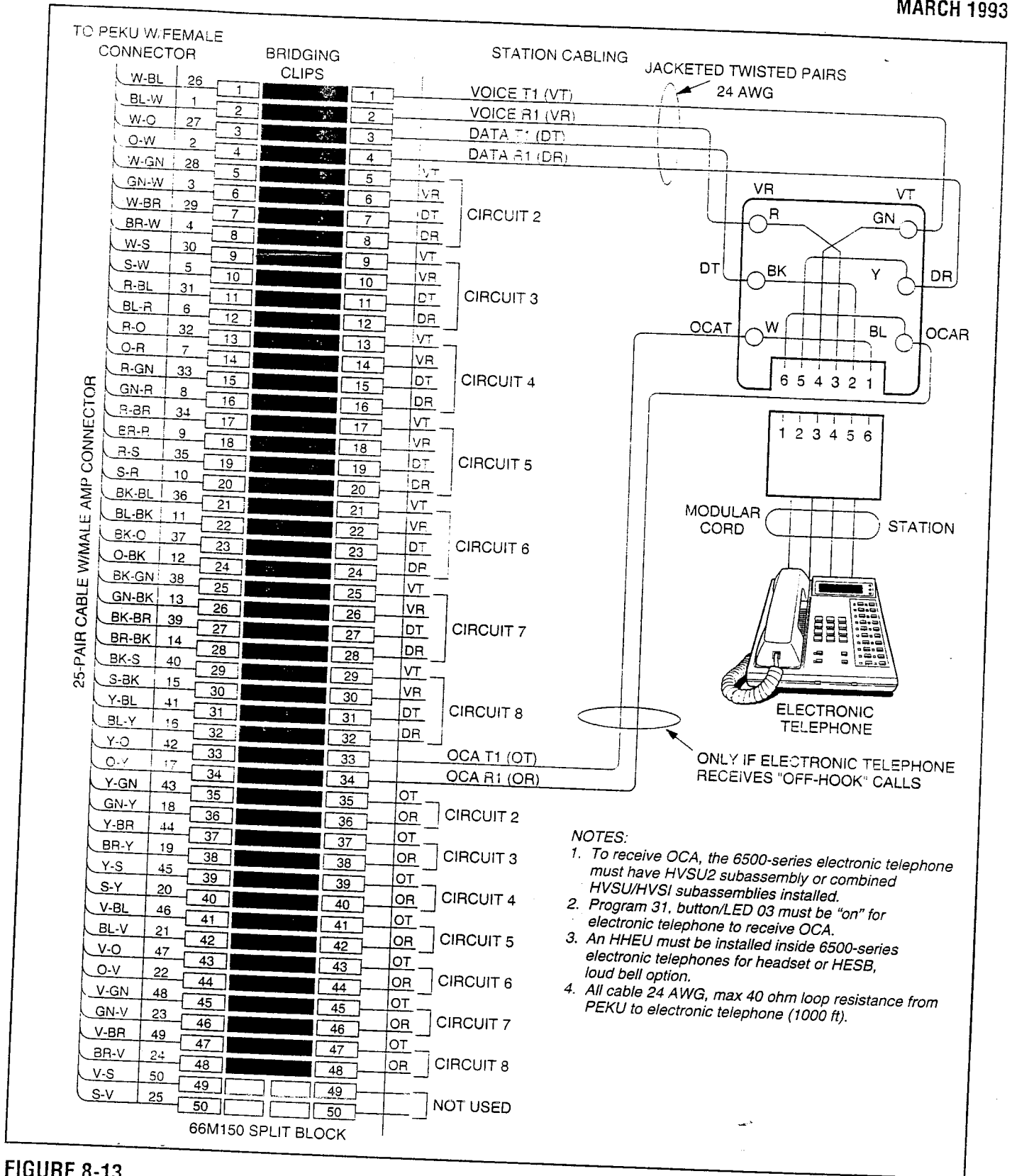
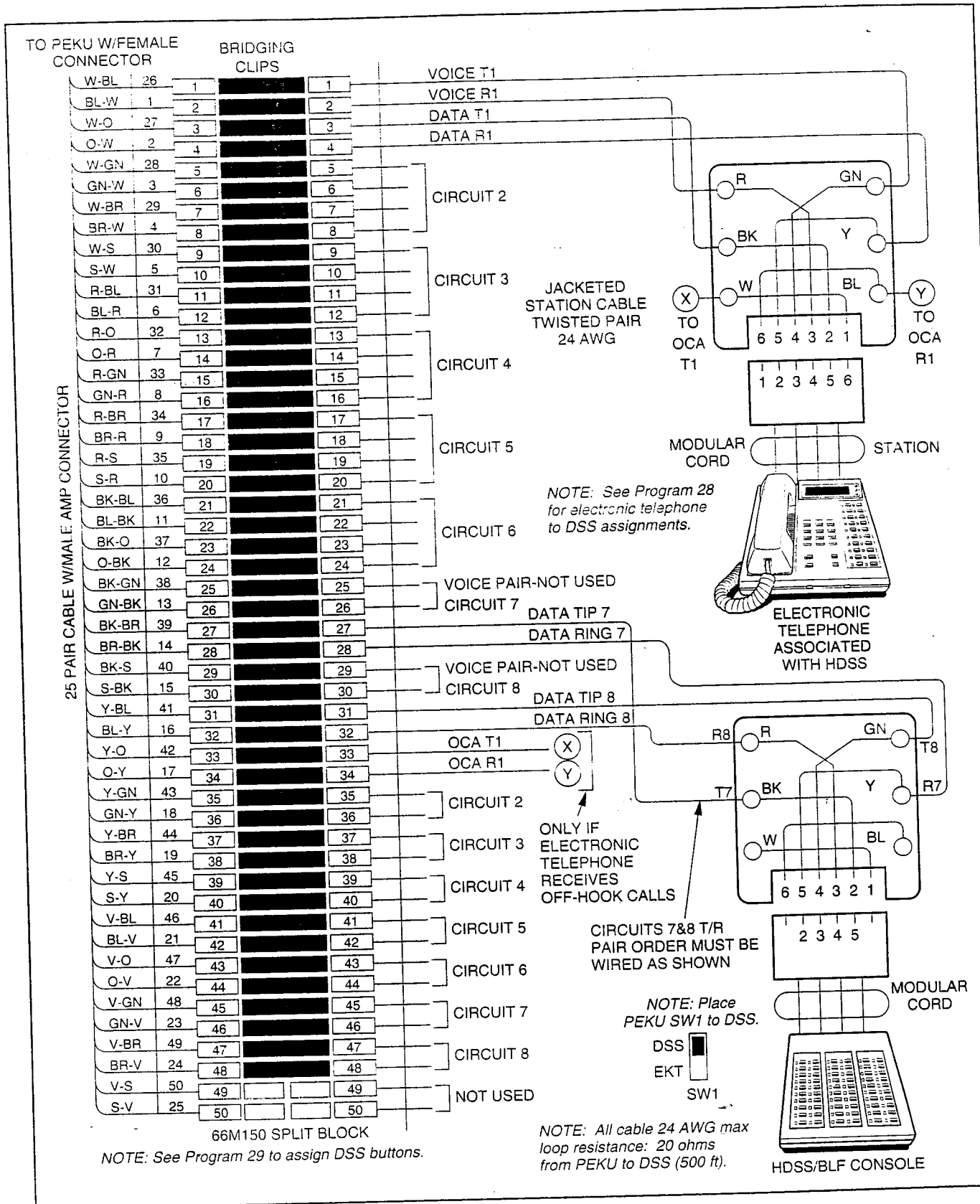
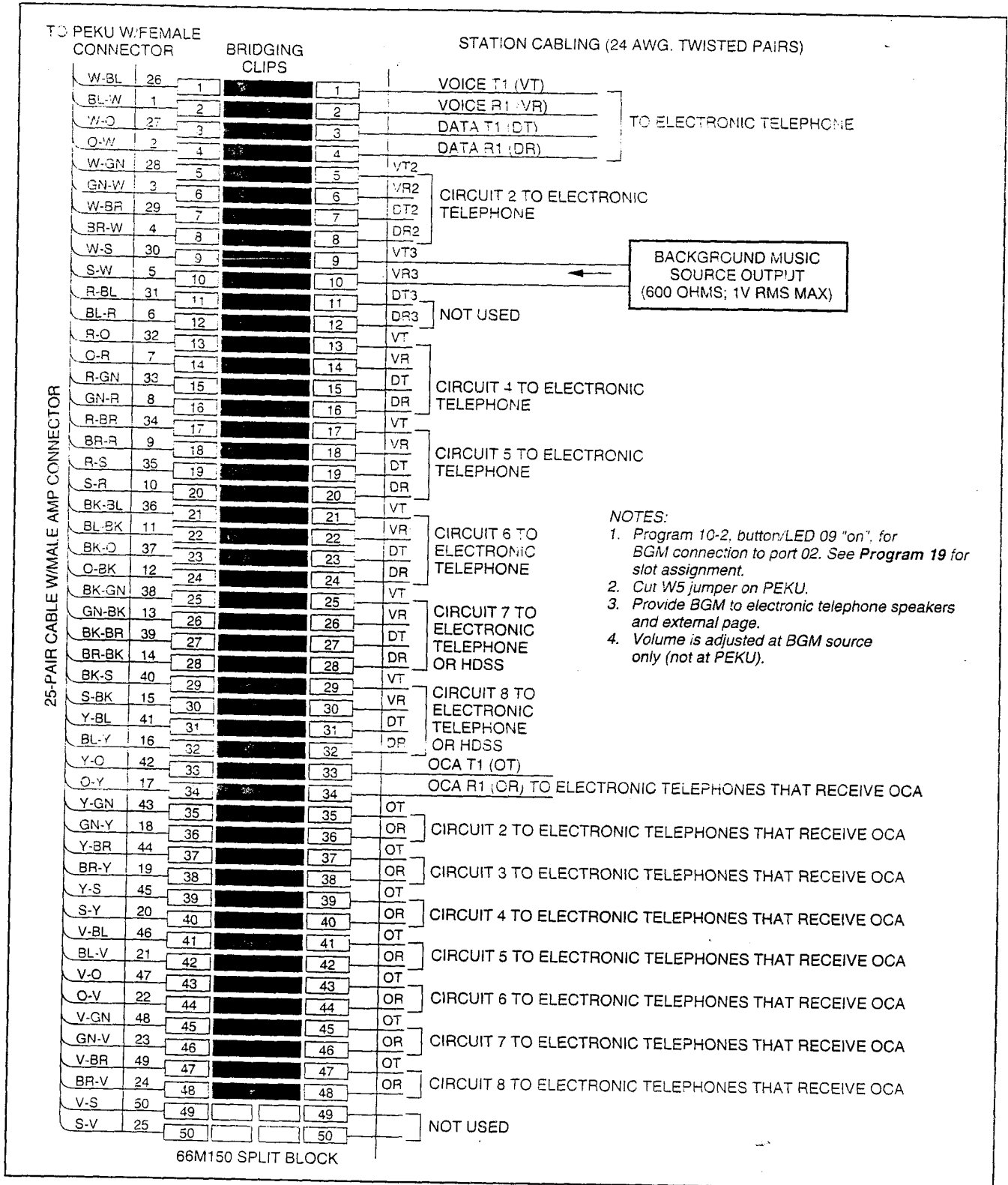


FIGURE 8-13  
DK16 MDF WIRING/ELECTRONIC TELEPHONE TO PEKU

**INSTALLATION-WIRING DIAGRAMS**  
**SECTION 100-816-208**  
**MARCH 1993**



**FIGURE 8-14**  
**DK16 MDF WIRING/HDSS CONSOLE AND ASSOCIATED ELECTRONIC TELEPHONE WIRING TO PEKU**



- NOTES:
1. Program 10-2, button/LED 09 "on", for BGM connection to port 02. See Program 19 for slot assignment.
  2. Cut W5 jumper on PEKU.
  3. Provide BGM to electronic telephone speakers and external page.
  4. Volume is adjusted at BGM source only (not at PEKU).

FIGURE 8-15  
DK16 PEKU BACKGROUND MUSIC CONNECTION

INSTALLATION-WIRING DIAGRAMS  
SECTION 100-816-208  
MARCH 1993

MDF BLOCK NO. \_\_\_\_\_ SLOT NO. \_\_\_\_\_

COLOR CODE	DESIGNATION	CKT NUMBER	PORT NUMBER	INTERCOM NUMBER	ELECTRONIC TELEPHONE/ DEVICE LOCATION
W-BI	VT	1			
BI-W	VR				
W-O	DT				
O-W	DR				
W-G	VT	2			
G-W	VR				
W-Br	DT				
Br-W	DR				
W-S	VT	3			1
S-W	VR				
R-BI	DT				
BI-R	DR				
R-O	VT	4			
O-R	VR				
R-G	DT				
G-R	DR				
R-Br	VT	5			
Br-R	VR				
R-S	DT				
S-R	DR				
Bk-BI	VT	6			
BI-Bk	VR				
Bk-O	DT				
O-Bk	DR				
Bk-G	VT	7			2
G-Bk	VR				
Bk-Br	DT				
Br-Bk	DR				
Bk-S	VT	8			2
S-Bk	VR				
Y-BI	DT				
BI-Y	DR				

NOTES:

1. Indicate if BGM or electronic telephone is connected (see **Program 10-2 and 19**); BGM connects to VT and VR, circuit 3 only (DT and DR not used).
2. Indicate if electronic telephone or HDSS console.
3. OCA wiring not shown, see MDF-to-electronic telephone wiring.

**FIGURE 8-16**  
**DK16 PEKU STATION/MDF CROSS CONNECT RECORD**

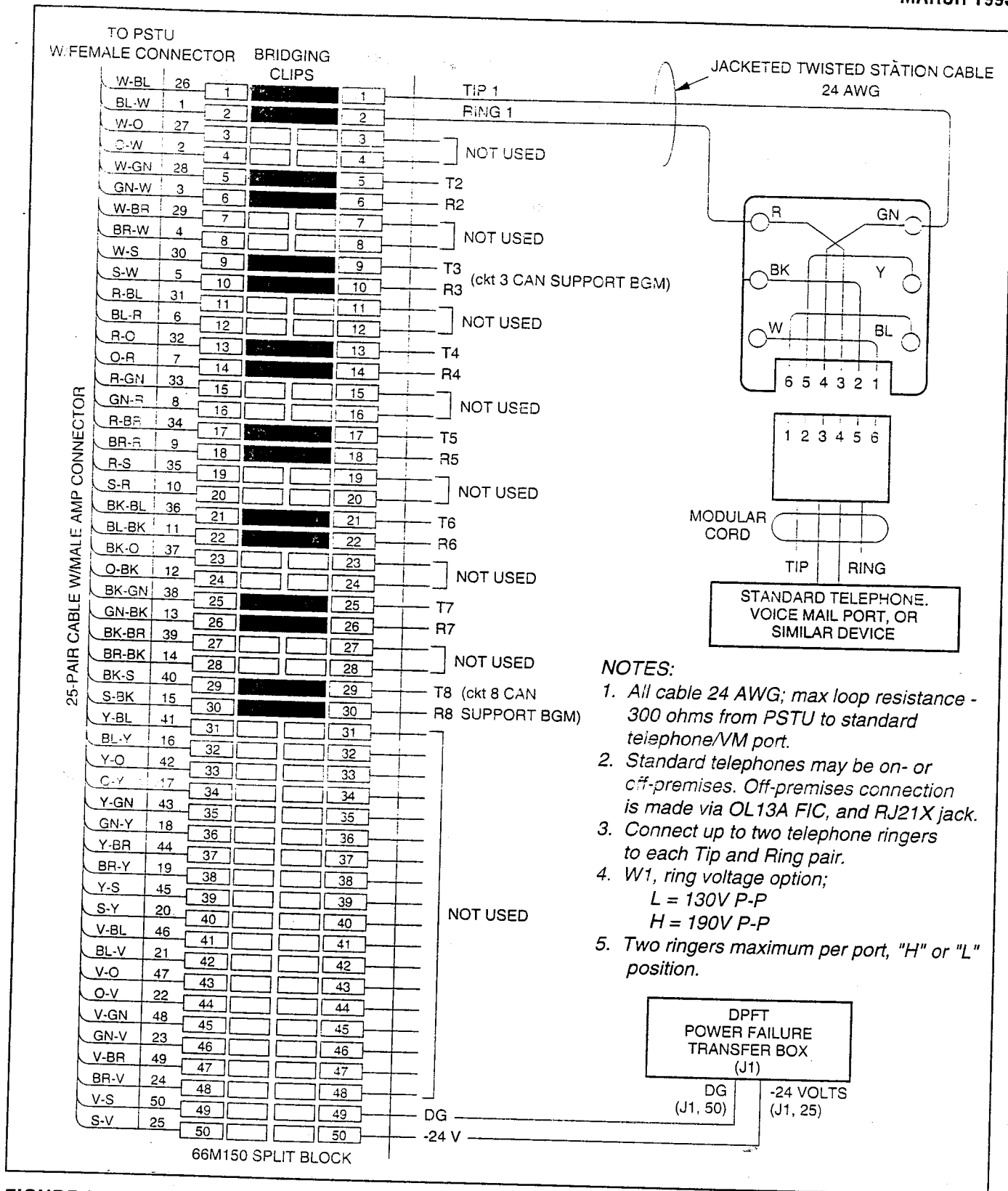


FIGURE 8-17  
DK16 MDF WIRING/STANDARD TELEPHONE, VOICE MAIL TO PSTU

**INSTALLATION-WIRING DIAGRAMS**  
**SECTION 100-816-208**  
**MARCH 1993**

MDF BLOCK NO. \_\_\_\_\_ DKSU SLOT NO. \_\_\_\_\_

COLOR CODE	DESIGNATION	CKT NUMBER	PORT NUMBER	INTERCOM NUMBER	STANDARD TELEPHONE/ DEVICE LOCATION
W-BI	T	1			
BI-W	R				
W-O	NOT USED				
O-W	NOT USED				
W-G	T	2			
G-W	R				
W-Br	NOT USED				
Br-W	NOT USED				
W-S	T	3			2
S-W	R				
R-BI	NOT USED				
BI-R	NOT USED				
R-O	T	4			
O-R	R				
R-G	NOT USED				
G-R	NOT USED				
R-Br	T	5			
Br-R	R				
R-S	NOT USED				
S-R	NOT USED				
Bk-BI	T	6			
BI-Bk	R				
Bk-O	NOT USED				
O-Bk	NOT USED				
Bk-G	T	7			
G-Bk	R				
Bk-Br	NOT USED				
Br-Bk	NOT USED				
Bk-S	T	8			2
S-Bk	R				
Y-BI	NOT USED				
BI-Y	NOT USED				

**NOTES:**

1. Indicate if standard telephone, voice mail port, etc.
2. Circuit 3 or 8 can support a Background Music (BGM) source.

**FIGURE 8-18**  
**DK16 PSTU STATION/MDF CROSS CONNECT RECORD**

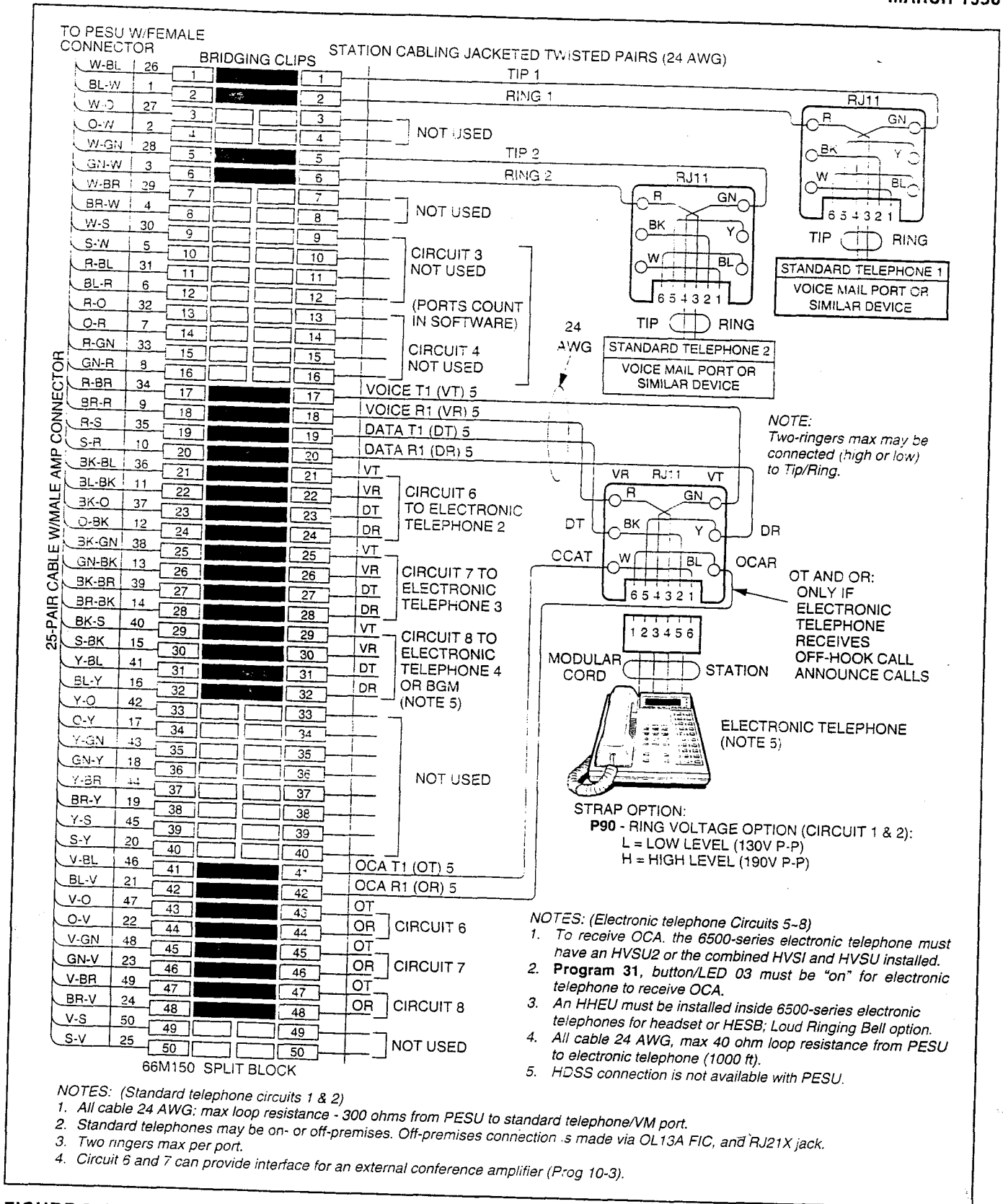


FIGURE 8-19  
DK16 PESU CIRCUIT CARD WIRING DIAGRAM



**INSTALLATION-WIRING DIAGRAMS**  
**SECTION 100-816-208**  
**MARCH 1993**

MDF BLOCK NO. \_\_\_\_\_

COLOR CODE	DESIGNATION	CKT NUMBER	PORT NUMBER	INTERCOM NUMBER	DEVICE/STANDARD TELEPHONE/ ELECTRONIC TELEPHONE LOCATION
W-BI	T	1			
BI-W	R				
W-O	NOT USED				
O-W	NOT USED				
W-G	T	2			
G-W	R				
W-Br	NOT USED				
Br-W	NOT USED				
W-S	NOT USED	3		N/A	N/A
S-W	NOT USED				
R-BI	NOT USED				
BI-R	NOT USED				
R-O	NOT USED	4		N/A	N/A
O-R	NOT USED				
R-G	NOT USED				
G-R	NOT USED				
R-Br	VT	5			
Br-R	VR				
R-S	DT				
S-R	DR				
Bk-BI	VT	6			2
BI-Bk	VR				
Bk-O	DT				
O-Bk	DR				
Bk-G	VT	7			1, 2
G-Bk	VR				
Bk-Br	DT				
Br-Bk	DR				
Bk-S	VT	8			1, 3
S-Bk	VR				
Y-BI	DT				
BI-Y	DR				

**NOTES:**

1. HDSS is not allowed.
2. Indicate if external amplifier is connected.
3. Indicate if BGM or electronic telephone is connected; BGM connects to VT and VR, circuit 8 only (DT and DR not used).
4. OCA wiring not shown, see MDF-to-electronic telephone wiring.

**FIGURE 8-20**  
**DK16 PESU STATION/MDF CROSS CONNECT RECORD**

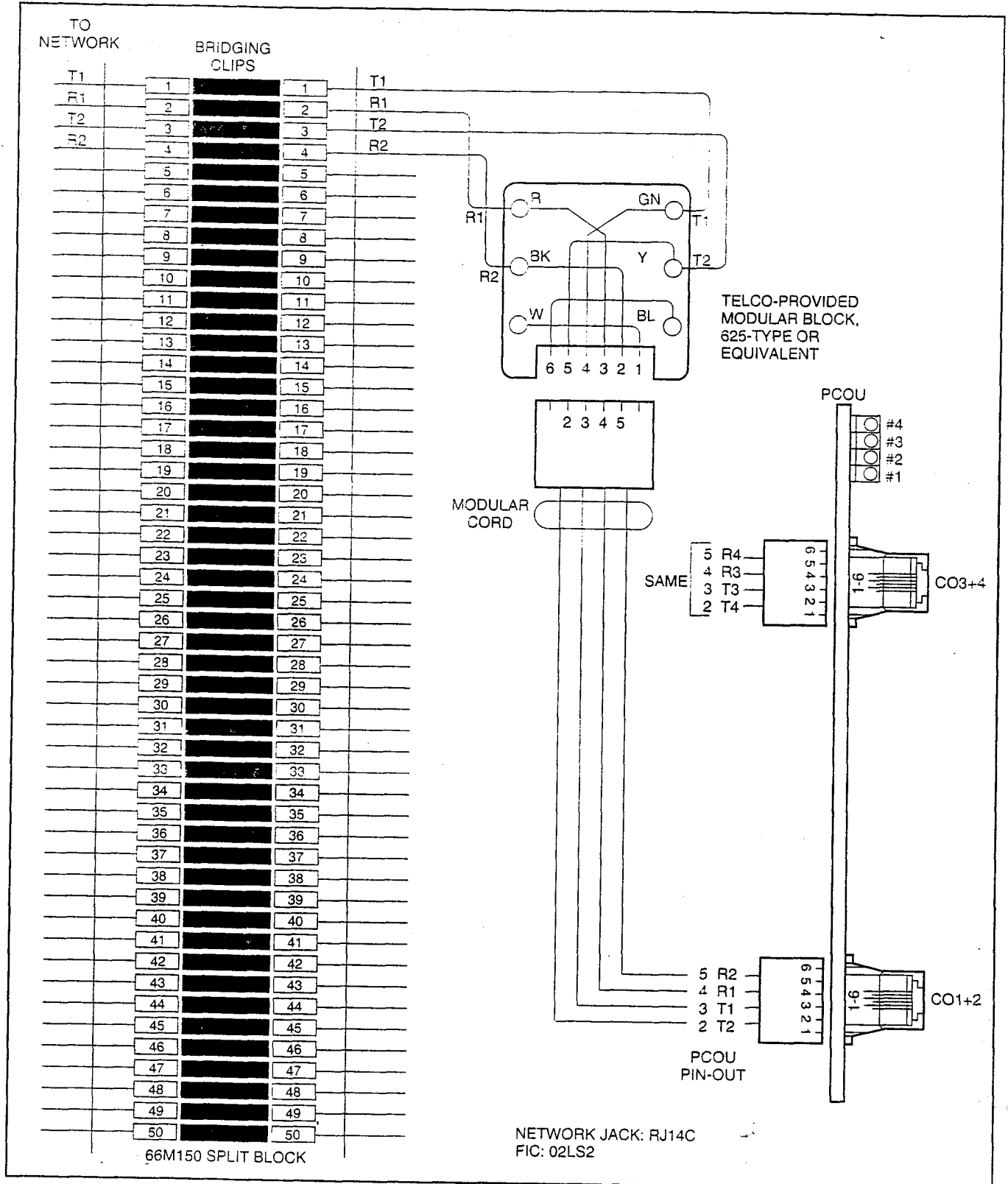
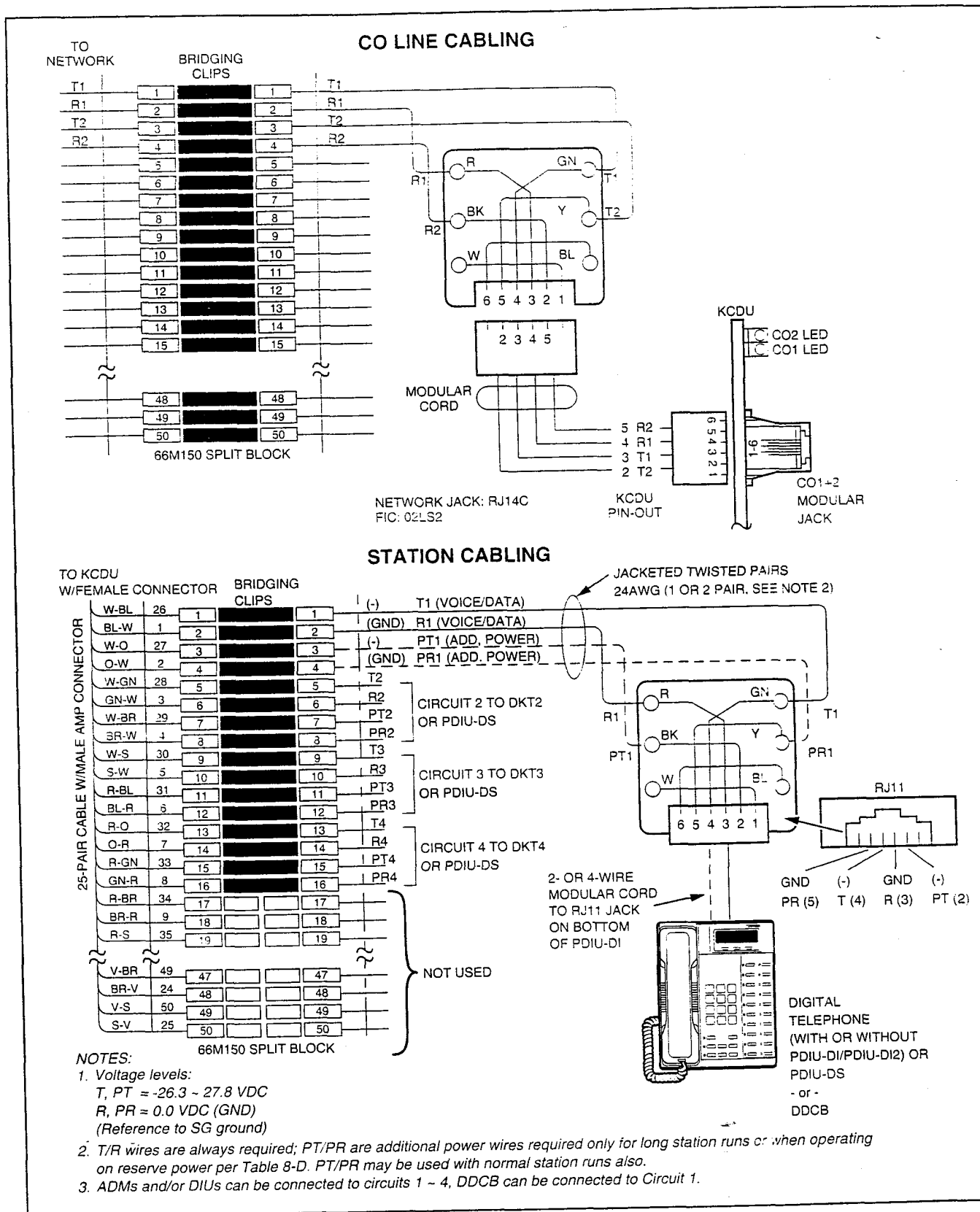


FIGURE 8-21  
DK16 MDF WIRING/CO LINES TO PCOU

**INSTALLATION-WIRING DIAGRAMS**  
**SECTION 100-816-208**  
**MARCH 1993**



**FIGURE 8-22**  
**DK16 MDF WIRING/CO LINES AND DIGITAL TELEPHONES TO KCDU**

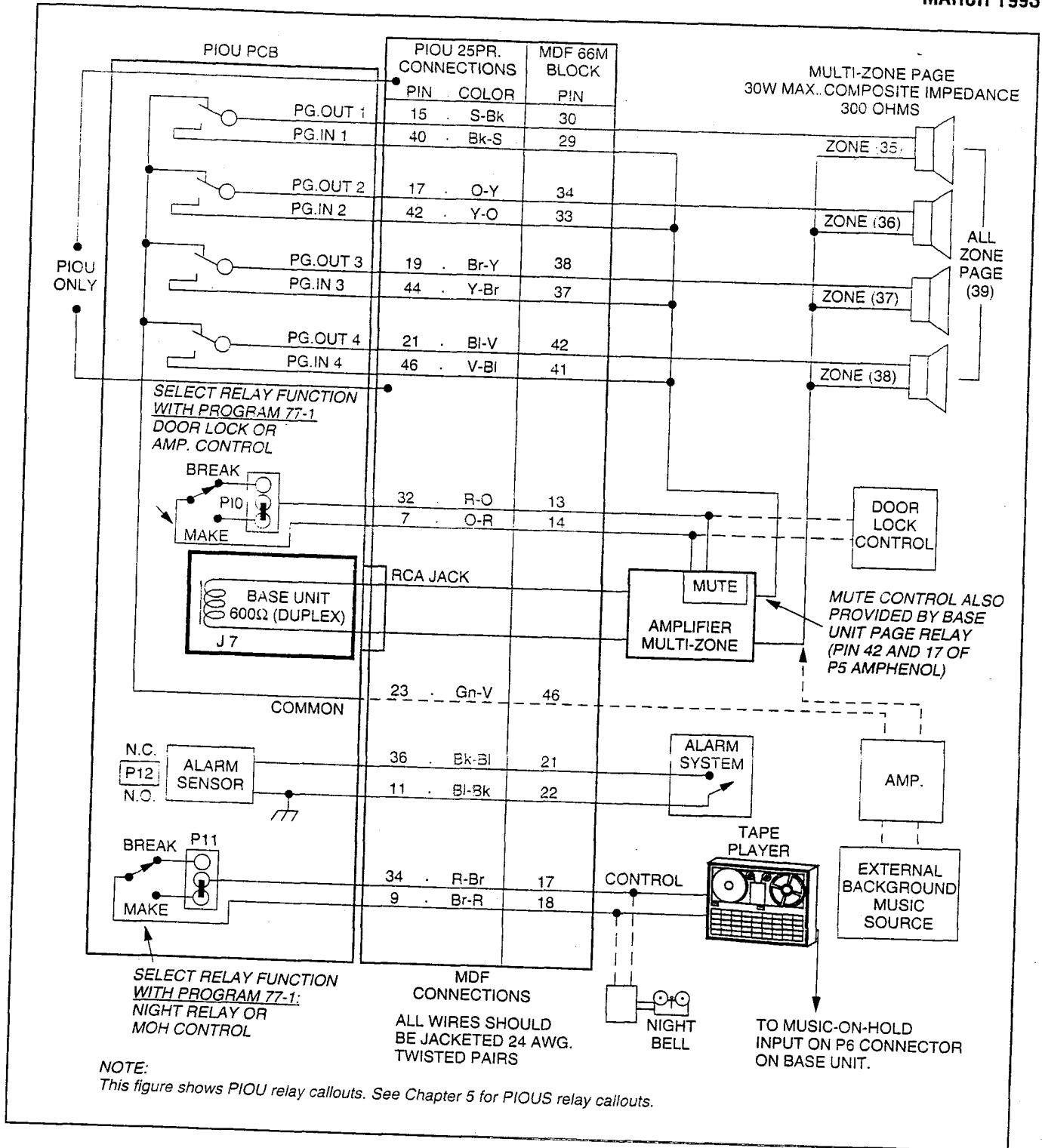
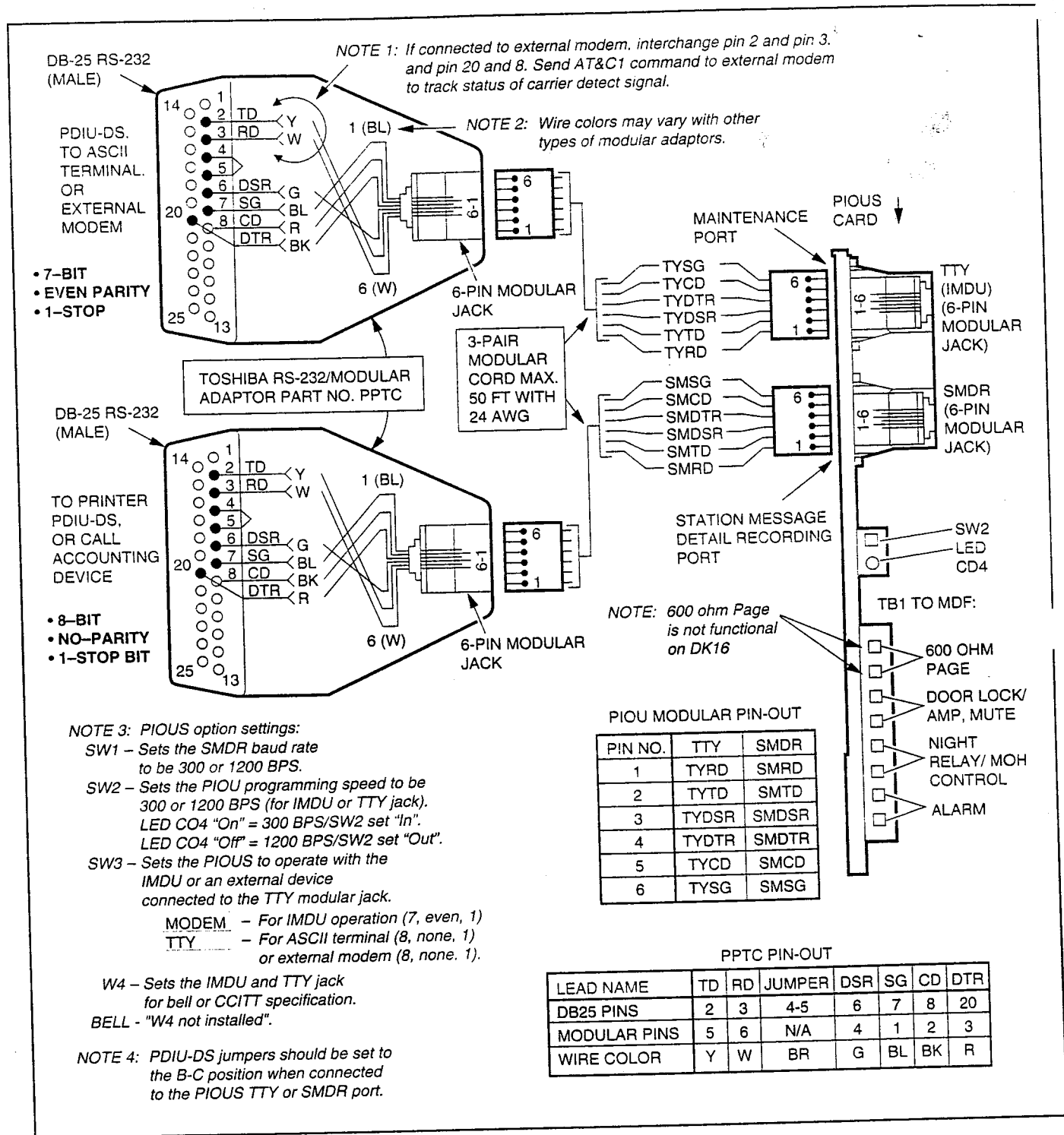


FIGURE 8-23  
DK16 MDF WIRING/PIU PERIPHERALS (25-PAIR)

**INSTALLATION-WIRING DIAGRAMS**  
**SECTION 100-816-208**  
**MARCH 1993**



**FIGURE 8-24**  
**DK16 PIOUS/TTY AND SMDR WIRING**

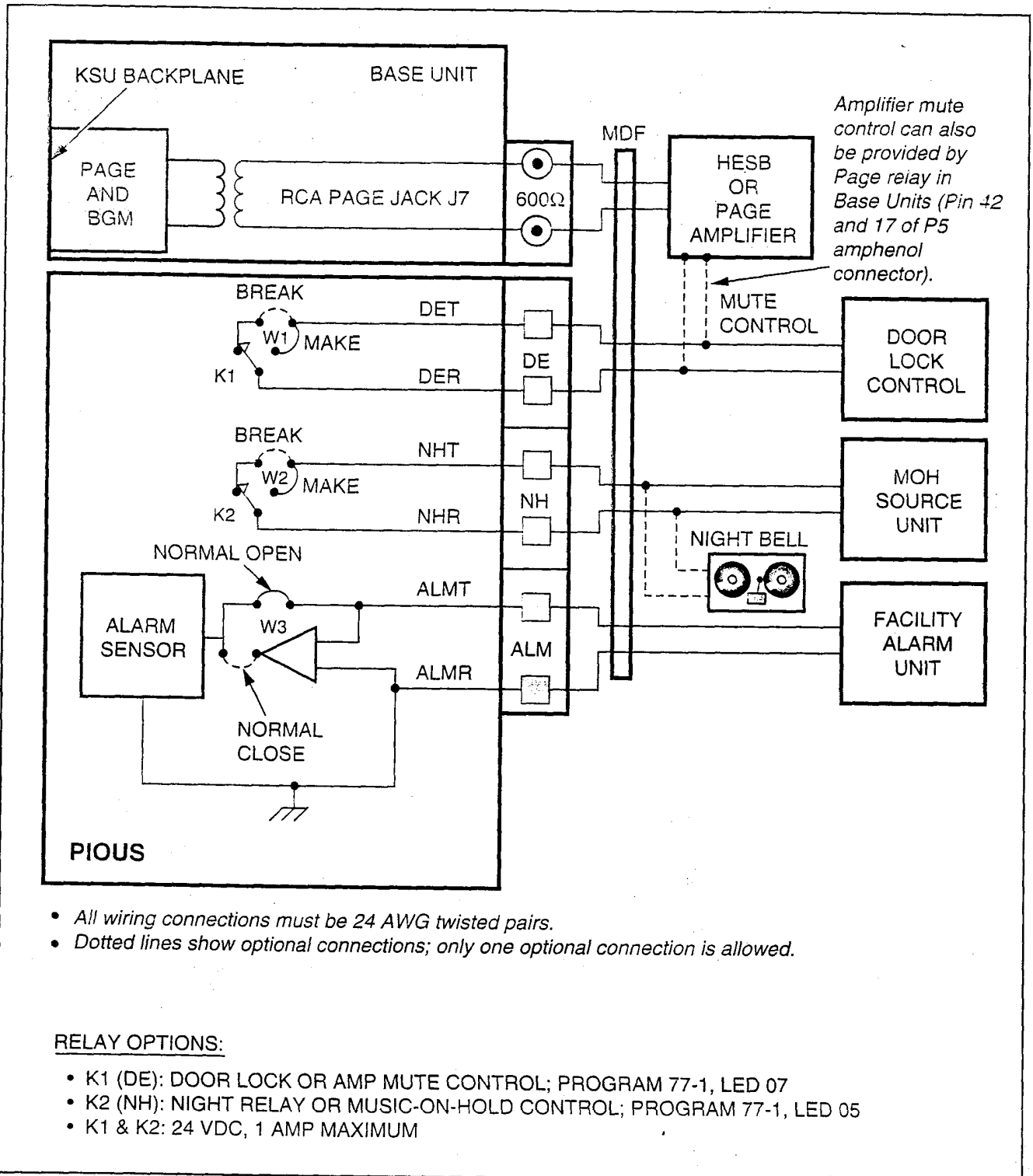
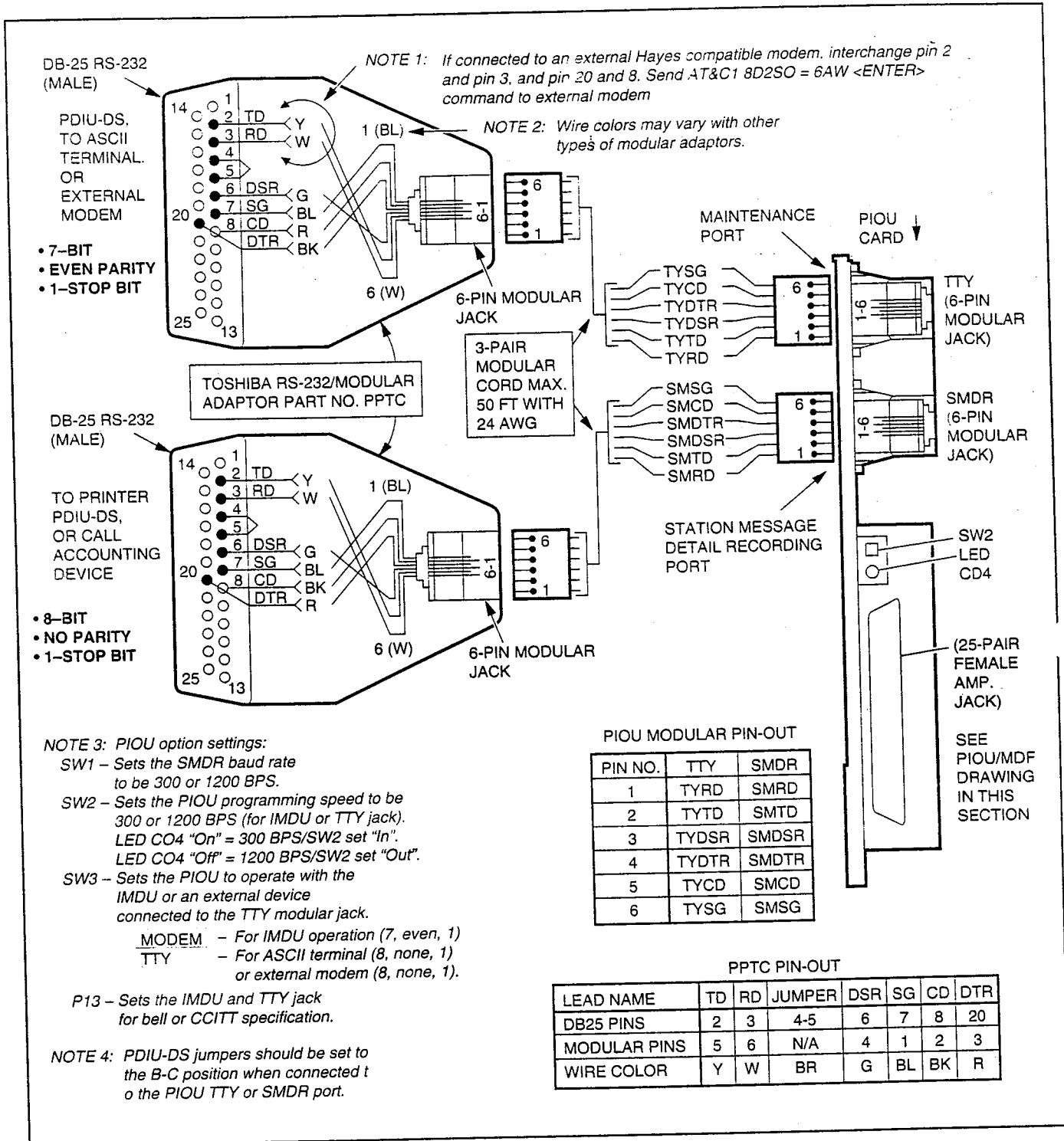


FIGURE 8-25  
DK16 PIOUS PAGE/RELAY/ALARM CONNECTIONS

**INSTALLATION-WIRING DIAGRAMS**  
**SECTION 100-816-208**  
**MARCH 1993**



**FIGURE 8-26**  
**DK16 PIU SMDR/TTY OPTIONS AND WIRING**

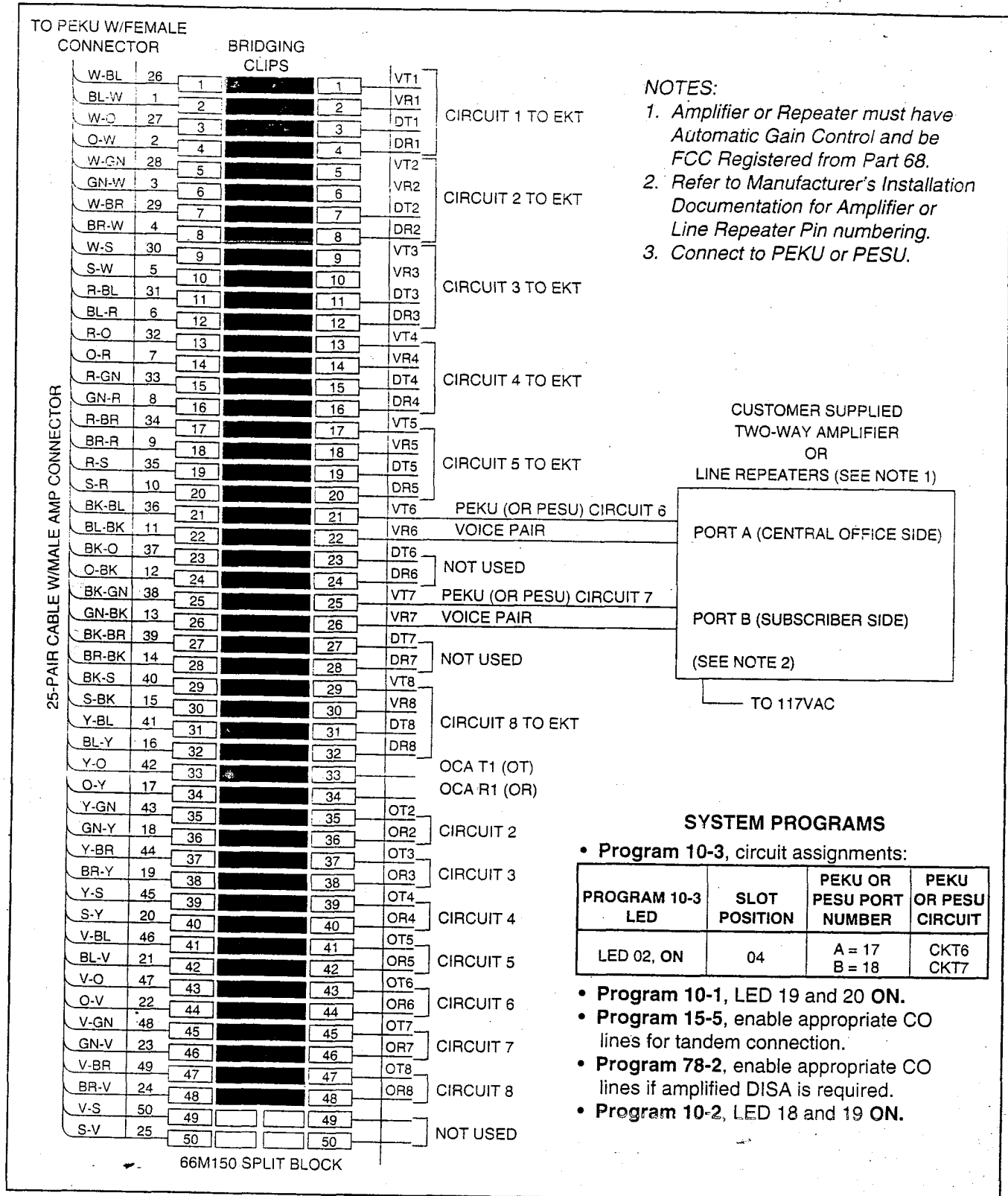
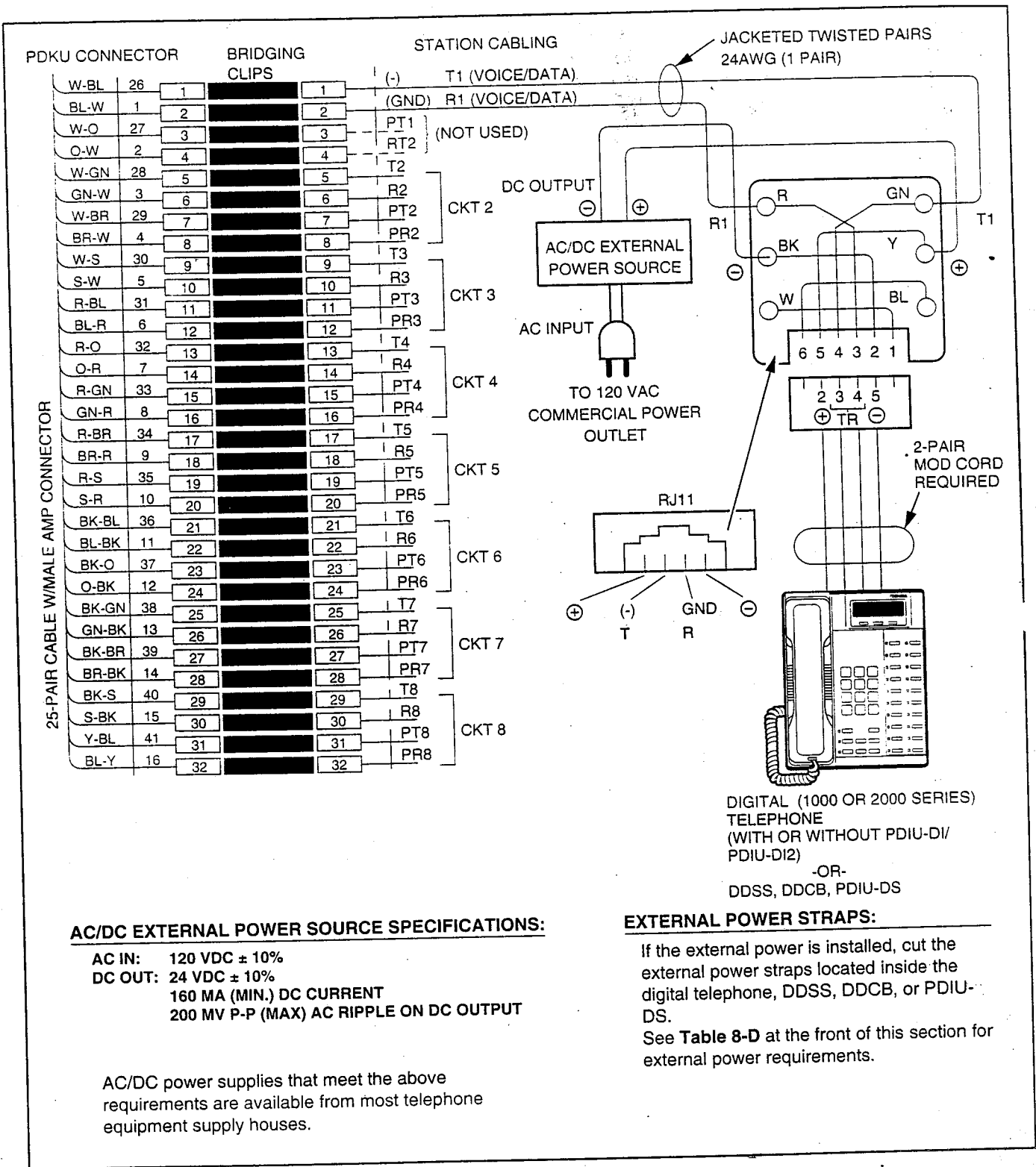


FIGURE 8-27  
DK16 MDF WIRING/AMPLIFIED TWO-CO LINE CONFERENCE



**INSTALLATION-WIRING DIAGRAMS**  
**SECTION 100-816-208**  
**MARCH 1993**



**FIGURE 8-28**  
**DK16 EXTERNAL POWER FOR DIGITAL TELEPHONE CONNECTION**

# ***Strata***<sup>®</sup> *DK8 & DK16*

## **PROGRAMMING PROCEDURES**

### **CHAPTER ONE INTRODUCTION**

## Table of Contents

PARAGRAPH	SUBJECT	PAGE
1	PURPOSE .....	1-1
2	ORGANIZATION .....	1-1
3	GENERAL PROGRAMMING INSTRUCTIONS .....	1-1
3.10	Programming Data Entry Overview .....	1-1
3.20	Programming Data Variations .....	1-2
3.30	Preparing the System for Programming .....	1-6
4	AFTER INITIALIZATION .....	1-8
5	TELEPHONE BUTTON LABELS .....	1-8

## TABLE LIST

TABLE	SUBJECT	PAGE
1-A	SIMPLE PROGRAM: PROGRAM 33 (STATION HUNTING) .....	1-3
1-B	MULTIDIMENSIONAL PROGRAM: PROGRAM 30 (STATION CLASS OF SERVICE) .....	1-4
1-C	PROGRAM 90/INITIALIZING PROGRAMS 00 ~ 97 .....	1-7
1-D	INITIALIZATION PROGRAM 92/INITIALIZING SPEED DIAL NUMBERS, VM ID CODES, CHARACTER MESSAGE MEMORY, TIMED REMINDERS, DIGITAL TELEPHONE VOLUME, AND CALL FORWARD BACKUP MEMORY .....	1-9
1-E	PROGRAM 03/SLOT ASSIGNMENTS .....	1-11
1-F	PROGRAM 00/SOFTWARE CHECK AND REMOTE MAINTENANCE SECURITY CODE ASSIGNMENTS .....	1-12
1-G	PROGRAM 04/PORT AND STATION NUMBER ASSIGNMENT .....	1-14
1-H	TELEPHONE BUTTON LABELS .....	1-16

## FIGURE LIST

FIGURE	SUBJECT	PAGE
1-1	PROGRAMMING BUTTON SEQUENCE OVERVIEW .....	1-2
1-2	TELEPHONE PROGRAMMING TEMPLATES .....	1-6
1-3	INITIALIZING DATA FOR PROGRAMS 00 ~ 97 WITH PROGRAM 90 .....	1-8
1-4	INITIALIZING SPEED DIAL NUMBERS, VM ID CODES, CHARACTER MESSAGE MEMORY, TIMED REMINDERS, DIGITAL TELEPHONE VOLUME, AND CALL FORWARD BACKUP MEMORY WITH PROGRAM 92 .....	1-10
1-5	SETTING SYSTEM DATE .....	1-15
1-6	SETTING SYSTEM TIME .....	1-15
1-7	SETTING SYSTEM DAY OF WEEK .....	1-15

## PURPOSE

1.01 The purpose of this programming section is to provide the system installer with instructions to set the detailed feature configuration and operation of the system.

1.02 This chapter provides an overview of the programming section, its organization, and some general programming instructions.

## 2 ORGANIZATION

2.01 This programming section is organized in modular chapters. The chapters are titled as follows:

Tech Info Inc. Call: (810) ~~754-3111~~ **395-0000**

2.02 **Chapter One—Introduction (Section 100-816-301).** Begins with an overview of the section's purpose and organization. Also included are basic instructions on how to program the system with a 20-button LCD digital or (in DK16 only) electronic telephone, some general programming notes, and a description of system initialization.

2.03 **Chapter Two—System Record Sheets and Instructions (Section 100-816-302).** Provides a record sheet for every program (00 ~ 97) and instructions on how to fill them out. The system programmer programs the system from data on the record sheets. Program cross-reference tables in numerical and alphabetical order are also included. The same record sheets are used for DK8 and DK16; program options and data that does not apply to DK8 are shaded or noted with footnotes.

## 3 GENERAL PROGRAMMING INSTRUCTIONS

3.01 Programming data is entered from System Record Sheets at any 20-button LCD digital or (in DK16 only) electronic telephone; however only one Telephone can be in the program mode at a time. (It can also be entered from an on-site or off-site ASCII terminal. Both of these programming alternatives require optional hardware. See Remote Administration & Maintenance Procedures, Section 100-816-600, for details.) System Record Sheets document a specific system's data configuration, including attributes of a feature or group of

features. The record sheets are organized by program number in most cases.

### 3.10 Programming Data Entry Overview

3.11 Keystrokes for entering data from System Record Sheets follow a five-step pattern, detailed in the following description and illustrated in Figure 1-1.

**NOTE:**

*Button (key) sequences that stay the same for every program are abbreviated and shaded on each record sheet, button sequences that are unique for every program are white.*

- 1) In Step 1, enter the programming mode by pressing a series of buttons shown in Figure 1-1. To save space on the record sheets, the abbreviation "P" denotes this entry sequence. "P" buttons are always shaded.

**NOTE:**

*The LCD will continue to display idle status information—station number, date, and time—until Step 1 is finished.*

- 2) In Step 2, enter the program number. This sequence is unique for every program. The buttons are white and never abbreviated.

**NOTE:**

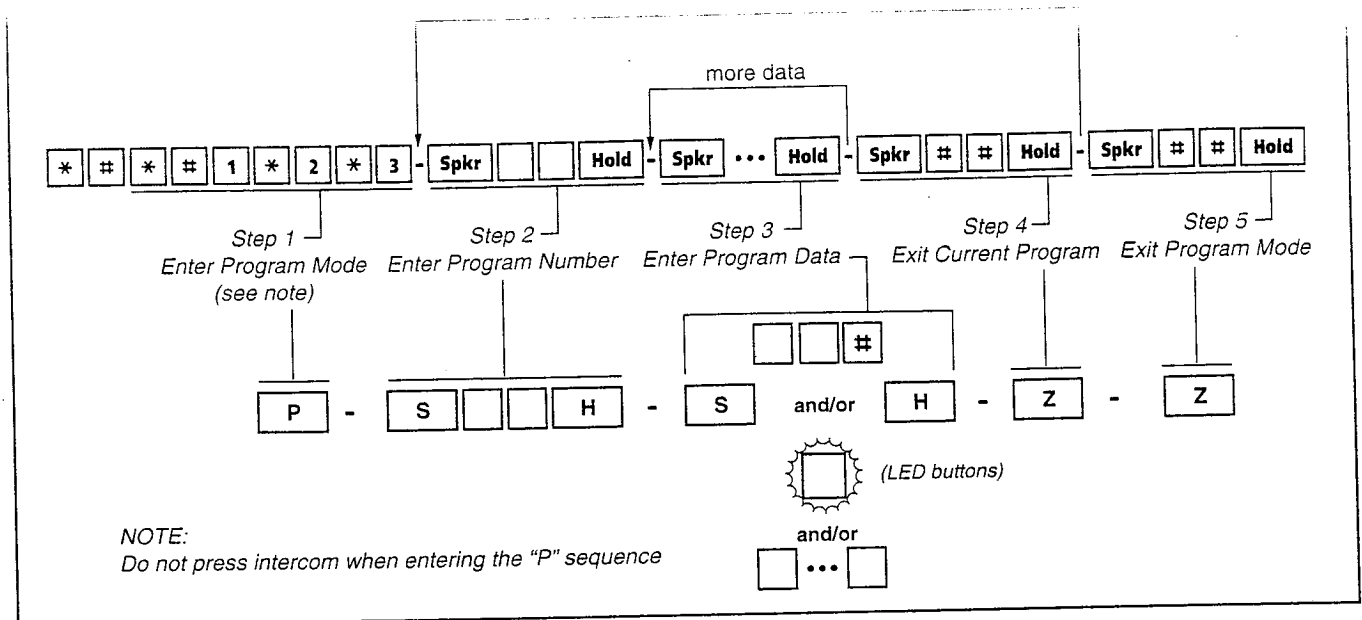
*When the speaker button is pressed at the beginning of Step 2, there will be a beep tone and "PROGRAM=\_" will appear on the LCD.*

- 3) In Step 3, enter the program data. Again, this sequence is unique for every program. (See Paragraph 3.20 for more information.) The buttons are white and never abbreviated. To make another entry, repeat Step 3 until ready to exit the current program.

**NOTE:**

*See Paragraph 3.20 for a description of program data entry methods.*

- 4) In Step 4, exit the current program. This sequence never changes. To save space on the record sheets, abbreviation "Z" denotes the



**FIGURE 1-1**  
**PROGRAMMING BUTTON SEQUENCE OVERVIEW**

ending sequence. "Z" buttons are shaded. Upon exiting the current program, repeat Step 2 to enter another program or continue with Step 5 to exit the programming mode entirely.

- In Step 5, exit the programming mode by pressing the same buttons as in Step 4. This sequence also never changes.

**3.12** Each System Record Sheet has an abbreviated button sequence at the top of it like the one shown in Figure 1-1.

### 3.20 Programming Data Variations

**3.21** There are two ways to enter data in Step 3 (Figure 1-1) of a program: pressing the buttons on the dialpad and pressing the LED buttons. Many programs are multidimensional and involve both types of entry.

**3.22 Simple Programs.** Simple programs, such as **Program 33**, only require data to be specified through the dialpad. Data entered from the dialpad displays on the programming digital or electronic

telephone's LCD, along with prompts and confirmations. See Table 1-A for step-by-step data entry instructions for **Program 33**.

**3.23 Multidimensional Programs.** Once a program number is entered, the first dimension (usually a CO line number, a station logical port number, or a range of ports) must be specified from the dialpad. Upon specifying this first dimension, programming button LEDs 01 ~ 20 light in the default configuration. The status of each LED can be changed by pressing its associated button. Pressing the button while its LED is lit turns the LED off; pressing the button while its LED is off turns the LED on. **Program 30** is a multidimensional program; see Table 1-B for step-by-step data entry instructions for **Program 30**.

- Range Programming:** When programming a range of station ports (Step 5, Table 1-B), the station's programming LEDs indicate whether the data programmed matches for all items in the range:
  - LED On:** Indicates that all ports in the range are programmed with the data choice that lights the particular LED.

TABLE 1-A  
SIMPLE PROGRAM: PROGRAM 33  
(STATION HUNTING)

Step #	Press... ACTION description	LCD RESPONSE ...
1.	Use an LCD digital or electronic telephone. <b>Make sure the programming button strip template is installed on the programming telephone (see Paragraph 3.24).</b>	NO. OF STATION (10 ~ 29) JAN 20 SUN 06:43
2.	<b>* # * # 1 * 2 * 3</b> Enter programming mode.	PROGRAM MODE
3.	<b>SPKR 3 3 HOLD</b> Access Program 33. System beeps after <b>SPKR</b> key is pressed to indicate program number may be entered.	PROGRAM = 33 DATA STORE
4.	<b>SPKR</b> Prepare the system for a station port selection.	33 SELECT =
5.	<b>00 ~ 19 (00 ~ 09 for DK8)</b> Select the logical port number of the "Hunt From" station. Up to two digits followed by the # key, or a range of ports can be entered as specified on the record sheet.	33 SELECT = (00 ~ 19) HUNT TO =
6.	<b>00 ~ 19 (00 ~ 09 for DK8)</b> Enter the logical port number of the "Hunt To" point, as recorded on the system record sheet. Press LED key 01 to delete a digit from Hunt To point ports.	33 SELECT = (00 ~ 19) HUNT TO = (00 ~ 19)
7.	<b>HOLD</b> Secure data in system programming.	33 SELECT = (00 ~ 19) DATA PROGRAMMED
8.	<b>SPKR</b> Prepare system for another selection (go back to step 5), or exit Program 33 (continue with step 9).	33 SELECT =
9.	<b># # HOLD</b> Secure Program 33 data in system memory.	33 SELECT = ## DATA PROGRAMMED
10.	<b>SPKR</b> Exit Program 33. Enter another program number or exit programming mode (go to step 11). Speaker beeps to indicate it is exiting Program 33.	PROGRAM =
11.	<b># # HOLD</b> Exit programming mode.	NO. OF STATION (10 ~ 29) JAN 20 SUN 06:58

TABLE 1-8  
 MULTIDIMENSIONAL PROGRAM: PROGRAM 30  
 (STATION CLASS OF SERVICE)

Step #	Press... Action description	LCD RESPONSE ...
1.	Use an LCD electronic or digital telephone.  Make sure the programming button strip template is installed on the programming telephone (see Paragraph 3.24).	NO.OF STATION (10 ~ 29) JAN 20 SUN 06:43
2.	<b>* # * # 1 * 2 * 3</b> Enter programming mode.	PROGRAM MODE
3.	<b>SPKR 3 0 HOLD</b> Access Program 30. System beeps after <b>SPKR</b> button is pressed to indicate a program number may be entered.	PROGRAM = 30 DATA STORE
4.	<b>SPKR</b> Prepare system for a port number selection.	30 SELECT =
5.	<b>0 0 ~ 1 9 (0 0 ~ 0 9 for DK8)</b> Enter the logical port number where the station being defined is connected. Use two digits, followed by a # key. A range of ports can be entered as specified in the record sheet.	30 SELECT = (00 ~ 19)
6.	<b>LED keys 01 ~ 20</b> LED keys 01 ~ 20 activate features for each station port or port range. Make the following selections by turning the appropriate led key ON or OFF for each item (01 ~ 20) for each port, as marked on the system record sheet:  LED 01 ON: Speakerphone Enabled LED 02 ON: Microphone Key Lock Enabled LED 03 ON: Microphone ON at Start of Call LED 04 ON: Not Used LED 05 ON: Speed Dial Allowed LED 06 ON: Automatic Busy Redial Access Enabled LED 07 ON: OCA/Busy Override Automatic LED 08 ON: Forced Account Code Enabled LED 09 ON: Toll Restriction Override Code Revision Authority LED 10 ON: DISA Security Code Change Allowed LED 11 ON: Dial Pulse (DTMF Off) for Standard Telephone	

TABLE 1-5 (CONTINUED)  
 MULTIDIMENSIONAL PROGRAM: PROGRAM 30,  
 STATION CLASS OF SERVICE

Step #	Press... Action description	LCD RESPONSE ...
6.	<p><b>LED keys 01 ~ 20 (continued)</b></p> <p>LEDs 12 and 13 ON: Digital Telephone Handset Receiver Volume</p> <p>LED 14 ON: Account Codes Verified</p> <p>LED 15 ON: Verified Account Code Revision Authority</p> <p>LED 16 ON: Traveling Class of Service Code Revision Authority</p> <p>LED 17 ON: Do Not Disturb Override Allowed</p> <p>LED 18 ON: Executive Override Allowed</p> <p>LED 19 ON: Privacy Override Allowed</p> <p>LED 20 ON: Not Used</p> <p>If programming a port range, the LED indications are as follows:</p> <ul style="list-style-type: none"> <li>• LED-ON, all ports in range are enabled for that item.</li> <li>• LED-OFF, all ports in range are disabled for that item.</li> <li>• LED-FLASHING, some ports in range are enabled and some ports are disabled.</li> </ul>	
7.	<p><b>HOLD</b> Secure data in system programming.</p>	<p>30 SELECT = (00 ~ 19) DATA PROGRAMMED</p>
8.	<p><b>SPKR</b> Prepare system for another selection (go back to step 5), or exit Program 30 (continue with step 9).</p>	<p>30 SELECT =</p>
9.	<p><b>## HOLD</b> Secure Program 30 data in system memory.</p>	<p>30 SELECT = ## DATA PROGRAMMED</p>
10.	<p><b>SPKR</b> Exit Program 30. Enter another program number or exit programming mode (go to step 11). System beeps to indicate it is exiting Program 30.</p>	<p>PROGRAM =</p>
11.	<p><b>## HOLD</b> Exit programming mode.</p>	<p>NO. OF STATION (10 ~ 29) JAN 20 SUN 06:58</p>



- **LED On:** Indicates that data bits that are programmed with the data choice that does not light the particular LED.
- **LED Flashing:** Indicates that data is currently inconsistent for all ports in the range. Some may be programmed with the LED on, some with the LED off.

**3.24 Telephone Programming Template.** Special programming buttonstrip templates (Figure 1-2) are provided with your system. A template must be on the programming telephone to properly enter data from the System Record Sheets. The templates assign numbers to each of the 20 buttons on the telephone that coincide with tables found in the record sheets.

**3.30 Preparing the System for Programming**

**3.31** This section explains how to prepare the system for programming.

**3.32 Minimum Hardware Requirements.** A system must have the following minimum hardware installed for programming, as described in the installation section, Section **100-816-200**:

- **Power Supply:** The power supply must test satisfactorily and must be on.
- **Battery Strap:** The **SW1** battery strap on the Key Service Unit should be in the On position.

Programming telephone. A digital or electronic telephone should have 20 flexible feature buttons, an LCD, and a programming template. The Programming telephone can be connected to any Digital or Electronic station port.

**NOTE:**

*Electronic telephones are not supported by the STRATA DK8.*

**3.33 Completing the Record Sheets.** Ensure that the Basic System Record Sheets, Toll Restriction System Record Sheets, and Least Cost Routing System Record Sheets have been completely filled out. If they have not been, do so before continuing. The Record Sheets are in Programming Procedures Chapter 2.

**3.34 Initializing the System.** The system's memory must be cleared by initializing its data. Initializing data activates standard, default data assignments (stored in ROM).

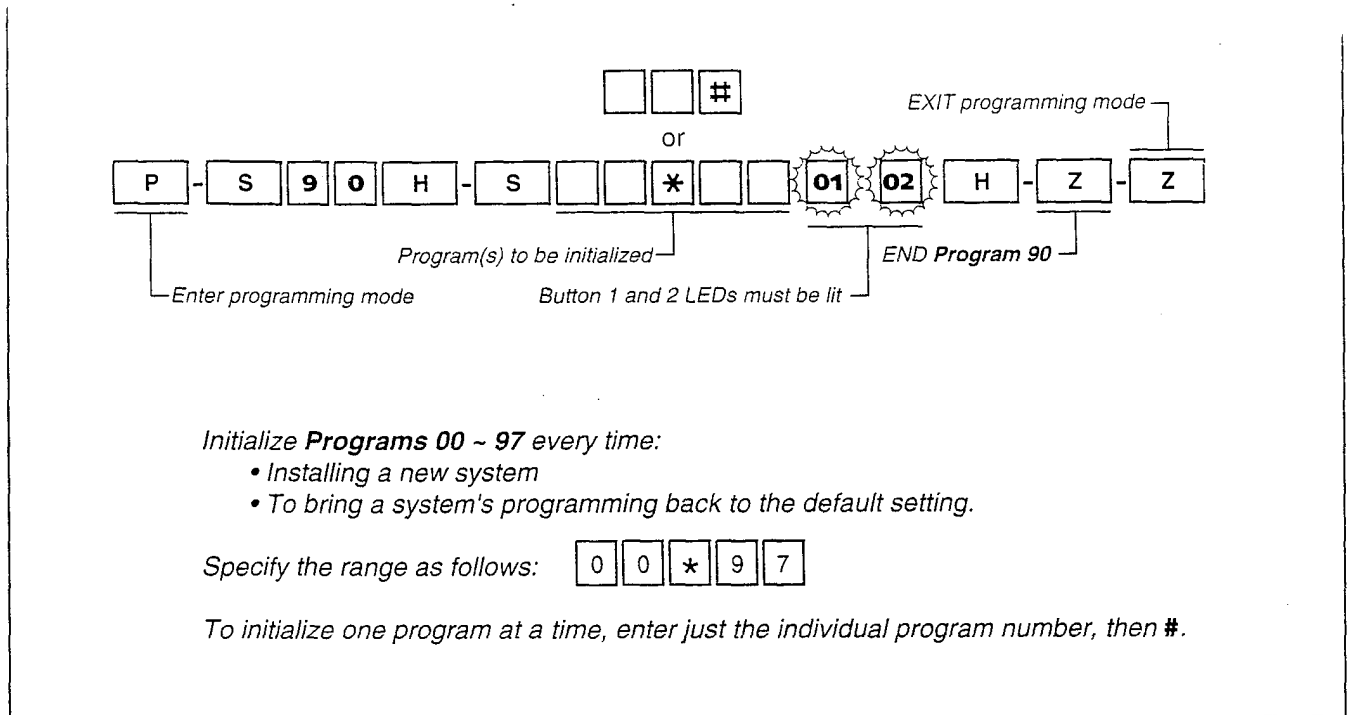
**3.35 Initialize Programs 00 ~ 97 Data with Program 90:** Always initialize a system with **Program 90** when it is first installed, or when its software must be brought to the default configuration. If only minor programming changes are being added to a system in which the programming is basically correct, do not run **Program 90**. Follow the steps in Table 1-C and Figure 1-3 to run **Program 90**.

Programming Keystrip Button Layouts									
DKT 2000 and EKT 6500 Series					DKT 1000 Series				
10	20	16	17	18	19	20	11	12	13
09	19	06	07	08	09	10	06	07	08
08	18	05	04	03	04	05	01	02	03
07	17	04	03	02	03	04	01	02	03
06	16	03	02	01	02	03	01	02	03
05	15	02	01		01	02			
04	14	01							
03	13								
02	12								
01	11								

**FIGURE 1-2**  
**TELEPHONE PROGRAMMING TEMPLATES**

TABLE 100  
PROGRAM 90  
INITIALIZING PROGRAMS 00 ~ 97  
See Program 90 System Record Sheet

Step #	Press... Action description	LCD RESPONSE ...
1.	Use an LCD digital or electronic telephone with a programming template.	NO. OF STATION (10 ~ 29) JAN 20 SUN 06:30
2.	<b>* * * # 1 * 2 * 3</b> Enter programming mode.	PROGRAM MODE
3.	<b>SPKR 9 0 HOLD</b> Access Program 90. System beeps after <b>SPKR</b> button is pressed to indicate the program number can be entered.	PROGRAM = 90 DATA STORE
4.	<b>SPKR</b> Prepare system for the programs to be initialized.	90 SELECT =
5.	<b>0 0 * 9 7+ LED keys 01 &amp; 02</b> Enter program numbers individually or in a range. For a range, separate the low program number and the high program number with an asterisk. <i>NOTE:</i> <i>To initialize only one program, enter the two digit program number followed by a # ( <input type="checkbox"/> <input type="checkbox"/> # ), then press Key 01 &amp; 02.</i>	90 SELECT = 00*97 DATA CLR
6.	<b>HOLD</b> (LEDs 01 and 02 flash rapidly) Secures data in system programming. LEDs 01 and 02 flash.	90 SELECT = 00*97 DATA PROGRAMMED
7.	<b>SPKR</b> Prepare system for another selection (go back to step 5), or exit Program 90 (continue with step 8).	90 SELECT =
8.	<b># # HOLD</b> Secure Program 90 data in system memory.	90 SELECT = ## DATA PROGRAMMED
9.	<b>SPKR</b> Exit Program 90. Enter another program number or exit programming mode (go to step 10). System beeps to indicate it's exiting Program 90.	PROGRAM =
10.	<b># # HOLD</b> Exit programming mode. <i>NOTE:</i> The system will not allow the <b>SPKR</b> LED to light to reenter the programming mode.	NO. OF STATION (10 ~ 29) JAN 20 SUN 06:42



**FIGURE 1-3**  
**INITIALIZING DATA FOR PROGRAMS 00 ~ 97 WITH PROGRAM 90**

**3.36 Initialize Speed Dial Numbers, Voice Mail Identification Codes, Character Message Memory, Timed Reminders, Digital Telephone Volume, and Call Forward Backup Memory with Program 92.** Complete this step if the system is being installed for the first time, or when all currently programmed Speed Dial numbers or the like must be deleted. Follow the steps in Table 1-D and refer to Figure 1-4.

**4 AFTER INITIALIZATION**

**4.01** Immediately after initializing the system, **Program 03** must be run to inform the software of the system hardware configuration (Table 1-E), **Program 00** to assign remote maintenance security codes and to check the system software level (Table 1-F), and **Program 04** to assign station numbers (Table 1-G). Anytime after initialization, the time and date can be set. Refer to Figures 1-5,

1-6, and 1-7 on instructions on how to set the time and date.

**NOTE:**

*It is not necessary to run **Program 03** for the STRATA DK8.*

**4.02** Enter data from the record sheets. For help in entering program data from the record sheets, see Tables 1-A and 1-B. The data entry methods used in these tables reflect the entry methods used for most of the programs.

**5 TELEPHONE BUTTON LABELS**

**5.01** This programming section makes references to specific telephone buttons. Depending on the telephone, the label designations for these buttons vary. The labels referred to in this section appear on the 2000-series Digital Telephones; see Table 1-H for the labels of other telephone models.

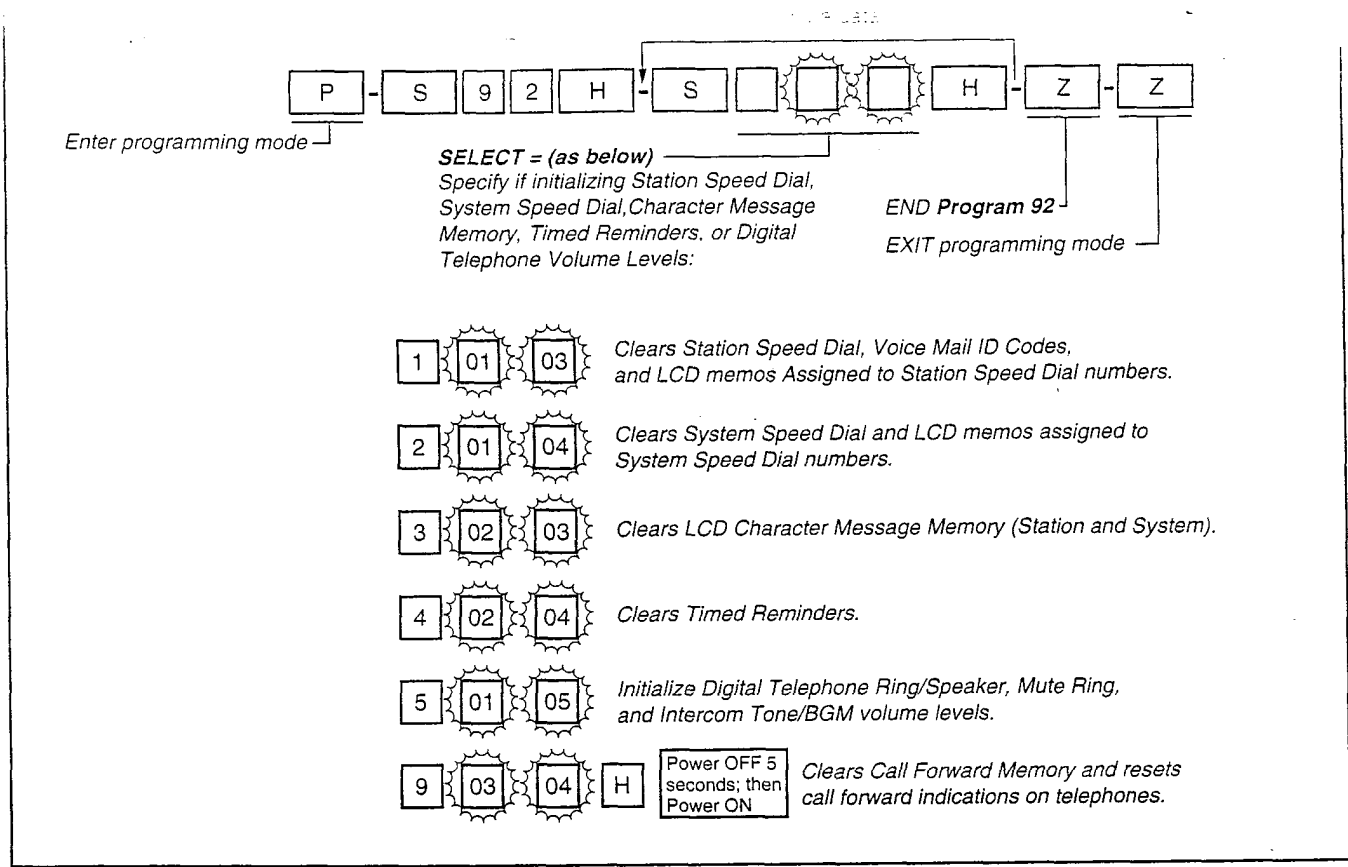
INITIALIZATION PROGRAM 92

INITIALIZING SPEED DIAL NUMBERS, VM ID CODES, CHARACTER MESSAGE MEMORY, TIMED REMINDERS, DIGITAL TELEPHONE VOLUME, AND CALL FORWARD BACKUP MEMORY

Step #	Press... Action description	LCD RESPONSE ...
1.	Use an LCD digital or electronic telephone with programming template.	NO. OF STATION (10 ~ 29) JAN 20 SUN 06:43
2.	<b>* * * # 1 * 2 * 3</b> Enter programming mode.	PROGRAM MODE
3.	<b>SPKR 9 2 HOLD</b> Access Program 92. System beeps after <b>SPKR</b> button is pressed to indicate when to enter program number.	PROGRAM = 92 DATA STORE
4.	<b>SPKR</b> Prepare system for selection of programs to initialize. For new system installation, always perform 5A ~ 5F.	92 SELECT =
5.	Select one of the following: A. <b>1 + LED keys 01 &amp; 03</b> Clears station speed dial, voice mail ID codes, and LCD memos assigned to station speed dial numbers. OR B. <b>2 + LED keys 01 &amp; 04</b> Clears system speed dial and LCD memos assigned to system speed dial numbers. OR C. <b>3 + LED keys 02 &amp; 03</b> Clears character message memory (station and system) and user name display. OR D. <b>4 + LED keys 02 &amp; 04</b> Clears timed reminders. OR E. <b>5 + LED keys 01 &amp; 05</b> Presets the Ring/Speaker, Mute Ring, and Intercom Tone/BGM, volume levels of all digital telephones to approximately midrange. OR F. <b>9 + LED keys 03 &amp; 04</b> Clears Call Forward Memory except Fixed Call Forward Memory.	92 SELECT = 1 EACH DIAL CLR  92 SELECT = 2 COMMON DIAL CLR  92 SELECT = 3 MSG CLR  92 SELECT = 4 TMR REMINDER CLR  92 SELECT = 5 DKT VR INITIAL  92 SELECT = 9 BACK UP RAM CLR
6.	<b>HOLD</b> (LEDs turn off) Secure data in system programming. Repeat steps 4 ~ 6 until steps 5A ~ 5F are completed (see note).	92 SELECT = (1~0) DATA PROGRAMMED
7.	<b>SPKR</b> Prepare system for another selection (go back to step 5), or exit Program 92 (continue with step 8).	92 SELECT =
8.	<b># # HOLD</b> Secure Program 92 data in system memory.	92 SELECT = ## DATA PROGRAMMED
9.	<b>SPKR</b> Exit Program 92. Enter another program number, or exit programming mode (go to step 10). System beeps to indicate it's exiting Program 92.	PROGRAM =
10.	<b># # HOLD</b> Exit programming mode.	NO. OF STATION (10 ~ 29) JAN 20 SUN 06:58

NOTE:

If the call forward memory was cleared, cycle system power after Step 6, if it is required to reset telephone call forward LCD displays or call forward button LED indications.



**FIGURE 1-4**  
INITIALIZING SPEED DIAL NUMBERS, VM ID CODES, CHARACTER MESSAGE MEMORY, TIMED REMINDERS, DIGITAL TELEPHONE VOLUME, AND CALL FORWARD BACKUP MEMORY WITH PROGRAM 92

TABLE 1-E  
PROGRAM 03  
SLOT ASSIGNMENTS  
(DK16 ONLY)

Step #	Press... <b>BUTTONS + LED keys</b> Action description	LCD RESPONSE ...
1.	Use an LCD digital or electronic telephone with a programming template.	NO. OF STATION (10 ~ 29) JAN 20 SUN 06:43
2.	<b>***#1*2*3</b> Enter programming mode.	PROGRAM MODE
3.	<b>SPKR 0 3 HOLD</b> Access Program 03. After <b>SPKR</b> key is pressed, system beeps to indicate program number may be entered.	PROGRAM = 03 DATA STORE
4.	<b>SPKR</b> Prepare system for a selection.	03 SELECT =
5.	Enter a PCB slot number (00~07).  The system defaults as follows: <b>0 0</b> Initialized data assigns CTU slot 00 to be non-optional, without a K4RCU. <b>0 1</b> Initialized data assigns DKU slot 01 to be non-optional without a door phone or DDSS console. <b>0 2</b> Initialized data assigns fixed KCOU slot 02 with code 11. <b>0 3</b> Initialized data assigns fixed KSTU slot 03 with code 31. <b>0 4 ~ 0 7</b> Initialized data assigns Expansion Unit's universal slots 04 ~ 07 to be empty, code 00.	03 SELECT = (00 ~ 07) CARD = Default code will appear here 03 SELECT = <u>00</u> CARD = 91     └─ SLOT NUMBER  03 SELECT = <u>01</u> CARD = 61     └─ SLOT NUMBER  03 SELECT = <u>02</u> CARD = 11     └─ SLOT NUMBER 03 SELECT = <u>03</u> CARD = 31     └─ SLOT NUMBER 03 SELECT = <u>04 ~ 07</u> CARD = 00     └─ SLOT NUMBER
6.	<b>0 0 ~ 9 2</b> Dial the PCB code recorded on the record sheet. Refer to the PCB code reference table on Program 03 System Record Sheet for a definition of the codes.	03 SELECT = (00 ~ 07) CARD = (00 ~ 92)
7.	<b>HOLD</b> Secure data in system programming.	03 SELECT = (00 ~ 07) DATA PROGRAMMED
8.	<b>SPKR</b> Prepare system for another selection (go back to step 5), or exit Program 03 (continue with step 9).	03 SELECT =
9.	<b>## HOLD</b> Secure Program 03 data in system memory.	03 SELECT = ## DATA PROGRAMMED
10.	<b>SPKR</b> Exit Program 03. Enter another program number, or exit programming mode (go to step 11). System beeps to indicate it's exiting Program 03.	PROGRAM =
11.	<b>## HOLD</b> Exit programming mode.	NO. OF STATION (10 ~ 29) JAN 20 SUN 06:58
12.	<b>In order to secure Program 03 entries, POWER OFF for 5 seconds, then POWER ON.</b>	

TABLE 1-7  
PROGRAM 00

SOFTWARE CHECK AND REMOTE MAINTENANCE SECURITY CODE ASSIGNMENTS

Press...

Step #

**BUTTONS + LED keys**

Action description

LCD RESPONSE ...

1.	Use an LCD digital or electronic telephone with a programming template.	NO. OF STATION (10 ~ 29) JAN 20 SUN 06:43
2.	<b>* * * # 1 * 2 * 3</b> Enter programming mode.	PROGRAM MODE
3.	<b>SPKR 0 0 HOLD</b> Speaker beeps to indicate when to enter program number. Access Program 00.	PROGRAM = 00 DATA STORE
4.	<b>SPKR</b> Prepare system for a selection.	00 SELECT =
5.	Select one of the following attributes: A. <b>0</b> View the software version. This attribute is not editable. OR B. <b>1</b> □□□□ Define the Level 1 remote maintenance security code from the System Record Sheet (four digits max.). Level 1 allows remote access to all programs and data. Default Level 1 security code is "0000." OR C. <b>2</b> □□□□ Define the Level 2 remote maintenance security code from the System Record Sheet (four digits max.). Level 2 allows remote entry to Programs 30 ~ 39 and 77 ~ 89 only. Default Level 2 security code is "0000." OR D. <b>8</b> View the software RAM Checksum. This attribute is not editable. The default checksum may change. OR E. <b>9</b> View the Power Supply Cycle Counter. This attribute is not editable. The counter indicates the number of times power is removed from the system after Program 00 was initialized via Program 90.	00 SELECT = 0 VERSION = QMA □.□ (DK8 ONLY) --OR-- VERSION = PSSA □.□ (DK16 ONLY) □.□ = SOFTWARE VERSION ID  00 SELECT = 1 PASSWORD = 0000  00 SELECT = 2 PASSWORD = 0000  00 SELECT = 8 SUM = XXXXXXXXX  00 SELECT = 9 COUNTER = XXXX
6.	<b>HOLD</b> Secure data in system programming. (Only works for "1" and "2")	00 SELECT = (0, 1, 2, 8, or 9) DATA PROGRAMMED
7.	<b>SPKR</b> Prepare system for another selection (go back to step 5), or exit Program 00 (continue with step 8).	00 SELECT =

TABLE 1-F (Continued)  
PROGRAM 00

## SOFTWARE CHECK AND REMOTE MAINTENANCE SECURITY CODE ASSIGNMENTS

Step #	Press... ACTION description	LCD RESPONSE ...
8.	<b>## HOLD</b> Secure Program 00 data in system memory.	00 SELECT = ## DATA PROGRAMMED
9.	<b>SPKR</b> Exit Program 00. Enter another program number or exit programming mode (go to step 10). System beeps to indicate it's exiting Program 00.	PROGRAM =
10.	<b>## HOLD</b> Exit programming mode.	NO. OF STATION (10 ~ 29) JAN 20 SUN 06:58



TABLE 1-G  
PROGRAM 04  
PORT AND STATION NUMBER ASSIGNMENT

Step #	Press... Action description	LCD RESPONSE ...
1.	Use an LCD digital or electronic telephone with a programming template.	NO. OF STATION (10 ~ 29) JAN 20 SUN 06:43
2.	<b>* * * # 1 * 2 * 3</b> Enter programming mode.	PROGRAM MODE
3.	<b>SPKR 0 4 HOLD</b> Access Program 04. System beeps after <b>SPKR</b> is pressed to indicate a program number may be entered.	PROGRAM = 04 DATA STORE
4.	<b>SPKR</b> Prepare system for a selection.	04 SELECT =
5.	<b>0 0 # ~ 1 9 #</b> Select the number of the logical port (use two digits), then #. Initialized data assigns station numbers 10 ~ 19 DK8 or 10 ~ 29 DK16.	04 SELECT = 00 INT = 10
6.	<b>□□□□</b> Enter the port's station number from the record sheet (four digits max.).  <i>NOTE: Station numbers must not exceed four digits, or conflict with feature access codes listed in Program 05 System Record Sheet.</i>	04 SELECT = 00 ~ 19 INT = XXXX
7.	<b>HOLD</b> Secure data in system programming.	04 SELECT = (00 ~ 19) DATA PROGRAMMED
8.	<b>SPKR</b> Prepare system for another port selection (go back to step 5), or exit Program 04 (continue with step 8).	04 SELECT =
9.	<b># # HOLD</b> Secure Program 04 data in system memory.	04 SELECT = ## DATA PROGRAMMED
10.	<b>SPKR</b> Exit Program 04. Enter another program number, or exit programming mode (go to step 10). System beeps to indicate it's exiting Program 04.	PROGRAM =
11.	<b># # HOLD</b> Exit programming mode.	NO. OF STATION (10 ~ 29) JAN 20 SUN 06:58

**HOW TO SET THE DATE**

The date can be set from an LCD electronic or digital telephone connected to a logical port 00. Press the following button sequence with the handset on-hook:



Date in year/month/day format (YYMMDD). If month or day is a single digit, precede with a zero (0).

Electronic telephones can use the # button if they do not have the **Redial (RDL)** button.

**FIGURE 1-5**  
**SETTING SYSTEM DATE**

**HOW TO SET THE TIME**

The time can be set from an LCD electronic or digital telephone connected to a logical port 00. Press the following button sequence with the handset on-hook:



Time in hours/minutes/seconds format (HHMMSS from 000000 to 235959). If any of these values is a single digit, precede with a zero (0).

Electronic telephones can use the # button if they do not have the **Redial (RDL)** button.

**FIGURE 1-6**  
**SETTING SYSTEM TIME**

**HOW TO SET THE DAY**

The day can be set from an LCD electronic or digital telephone connected to a logical port 00. Press the following button sequence with the handset on-hook:



Enter the digit for today's day:

- 1 = Sunday
- 2 = Monday
- 3 = Tuesday
- 4 = Wednesday
- 5 = Thursday
- 6 = Friday
- 7 = Saturday

Electronic telephones can use the # button if they do not have the **Redial (RDL)** button.

**FIGURE 1-7**  
**SETTING SYSTEM DAY OF WEEK**

TABLE 1-11  
TELEPHONE BUTTON LABELS

<i>2000-series Digital Telephone Button Label</i>	<i>Designation on other Telephone models</i>	<i>2000-series Digital Telephone Button Labels (cont)</i>	<i>Designation on other Telephone Models (cont)</i>
<b>Account Code</b>	<b>ACCNT</b>	<b>Mic</b>	<b>MIC</b>
<b>Alarm Reset</b>	<b>ALRM</b>	<b>Microphn Cut-off</b>	<b>MCO</b>
<b>All Call Page</b>	<b>AC</b>	<b>Modem</b>	<b>MODEM</b>
<b>Auto Busy Redial</b>	<b>ABR</b>	<b>Msg</b>	<b>MESSAGE</b>
<b>Auto Callback</b>	<b>ACB</b>	<b>Night Transfer</b>	<b>NT</b>
<b>Call Frwd All Calls</b>	<b>CFAC</b>	<b>Night Transfer1</b>	<b>NT1</b>
<b>Call Frwd Busy</b>	<b>CFB</b>	<b>Night Transfer2</b>	<b>NT2</b>
<b>Call Frwd Busy NAns</b>	<b>CFB/NA</b>	<b>Pooled Line Grp</b>	<b>PL</b>
<b>Call Frwd No Answer</b>	<b>CFNA</b>	<b>Privacy on Line</b>	<b>PRIVACY</b>
<b>Call Frwd to:_____</b>	<b>CFF</b>	<b>Privacy Release</b>	<b>PRV RLS</b>
<b>Cnf/Trn</b>	<b>CONF/TRNS</b>	<b>Redial</b>	<b>REDIAL or RDL</b>
<b>Data Call</b>	<b>DATA</b>	<b>Release Call</b>	<b>RLS</b>
<b>Data Release</b>	<b>DRLS</b>	<b>Save Last Number</b>	<b>SAVE</b>
<b>Directed Pickup</b>	<b>PKUP</b>	<b>SD</b>	<b>SD</b>
<b>Directed Pickup1</b>	<b>PKUP1</b>	<b>Spd Dial Lng Pause</b>	<b>PAU/L</b>
<b>Directed Pickup2</b>	<b>PKUP2</b>	<b>Spd Dial Pause</b>	<b>PAU</b>
<b>Do Not Disturb</b>	<b>DND</b>	<b>Speed Dial</b>	<b>SDS</b>
<b>DSS</b>	<b>DSS</b>	<b>Spkr</b>	<b>SPEAKER or SPKR</b>
<b>Flash</b>	<b>FLASH or MW/FL</b>	<b>Tel Set Music</b>	<b>BGM</b>
<b>Hold</b>	<b>HOLD</b>	<b>Tone Dial Select</b>	<b>TONE</b>
<b>Intercom</b>	<b>INT</b>	<b>Unlock Door</b>	<b>DRLK</b>
<b>LCD Msg Select</b>	<b>MSG</b>	<b>Vol</b>	<b>VOLUME</b>

# ***Strata***<sup>®</sup> *DK8 & DK16*

## **PROGRAMMING PROCEDURES**

### **CHAPTER TWO INSTRUCTIONS/RECORD SHEETS**

TABLE OF CONTENTS

PARAGRAPH	SUBJECT	PAGE
1	GENERAL .....	2-1
1.10	Record Sheet Data Entry .....	2-1
1.20	Logical Ports and Physical Ports .....	2-1
1.30	Basic System Record Instructions .....	2-1
2	TOLL RESTRICTION .....	2-22
3	TOLL RESTRICTION OVERVIEW .....	2-22
3.00	Toll Restriction Methods .....	2-22
3.10	Toll Restriction Features .....	2-22
4	COMPLETING THE TOLL RESTRICTION SYSTEM RECORD .....	2-23
4.10	Program 44B—Toll Restriction/Traveling Class Override Codes .....	2-23
4.20	Program 45-1—Toll Restriction Dial Plan .....	2-23
4.30	Program 45-2—Toll Restriction Disable .....	2-25
4.40	Program 45-3 ~ 6—Equal Access/Special Common Carrier Numbers and Authorization Code Digit Length .....	2-25
4.50	Program 45-8 ~ 9—Toll Restriction Override Code .....	2-25
4.60	Program 46-2 ~ 4—Toll Restriction Allowed/Denied Area Codes Assigned by Class .....	2-26
4.70	Program 46-6 ~ 8—Toll Restriction Allowed/Denied Office Codes Assigned by Class .....	2-26
4.80	Program 46-10 ~ 40—Toll Restriction Class Parameters (Classes 1 ~ 4) .....	2-26
4.90	Program 47—Toll Restriction Exception Office Codes Assigned by Area Codes (Table 1 ~ 8) .....	2-27
4.100	Program 48—Station Toll Restriction Classification .....	2-27
5	LEAST COST ROUTING .....	2-28
6	LEAST COST ROUTING OVERVIEW .....	2-28
6.00	Definition .....	2-28
6.10	LCR Schedule Assignments .....	2-28
6.20	Conditions .....	2-30
7	COMPLETING THE LEAST COST ROUTING SYSTEM RECORD .....	2-30
7.10	LCR CO Line Programming Reference Chart .....	2-30
7.20	Program 50 Series—LCR Definitions .....	2-31
7.30	Route Plan Overview .....	2-32
7.40	Program 55 Series—LCR Modified Digits Tables .....	2-34

FIGURE LIST

FIGURE	SUBJECT	PAGE
2-1	LCR OPERATIONAL BLOCK DIAGRAM .....	2-29

## 1 GENERAL

**1.01** This chapter consists of System Record Sheets and instructions on how to fill out each of them. The chapter begins with the instructions: first the basic program instructions, then the Toll Restriction instructions, and then the Least Cost Routing instructions. The remainder of the chapter contains the System Record Sheets, organized in the same sequence as the instructions.

### 1.10 Record Sheet Data Entry

**1.11** The System Record Sheets are used to record the assignment of features or operation of each program. The following descriptions and considerations of the available programming choices will be helpful when filling out the record sheets.

**1.12** Initialized data information can be found in the Notes at the bottom of each System Record Sheet.

### 1.20 Logical Ports and Physical Ports

**1.21** There are two types of ports in the STRATA DK8/DK16 systems. This distinction gives customers greater mobility in relocating their stations. Physical ports can be defined as the actual hardware—printed circuit board (PCB) circuit, wiring, and jack (RJ11) that stations plug into—that is connected to the system. Logical ports are attributes associated with a station (telephone)—station number, personal Speed Dial numbers, and the complement of features assigned to the station in system software programs. A Logical port always is associated with a physical port.

**1.22** Physical ports can be considered as fixed; they cannot be moved. Logical ports, though, are not fixed. They can be moved from one physical port to another physical port. It is important to note that logical ports can only be moved to related physical ports: Digital logical port (telephone) to digital physical port (QCDU and KSU digital circuits for STRATA DK8; PDKU, KCDU, and the Base Unit digital circuits for STRATA DK16), electronic logical port (telephone) to electronic physical port (PEKU and PESU for STRATA DK16), and standard logical port (standard telephone) to standard physical port (QSTU for STRATA DK8; PSTU, PESU, and KSTU for STRATA DK16).

When entering ports into program data, except in Program 01, always enter the logical port number.

### 1.30 Basic System Record Instructions

**Program 90—Initializing Programs:** All customer data can be cleared and set to the initialized state for any program or range of programs. If the system is being installed for the first time or if installing a KFCU in a STRATA DK16 (instructions specify), this program must be run to erase random data from RAM. Initialized data information can be found at the bottom of each program System Record Sheet. If the system is being installed for the first time or in a new location or when installing a KFCU in a STRATA DK16 (if instructions specify), all programs (00-97) should be initialized.

**Program 92—Initializing Speed Dial Numbers, Voice Mail ID Codes, Character Message Memory, Timed Reminders, Call Forward, and Digital Telephone Volume Levels:** A previously entered or random data (of the type listed) is cleared by this program. This program must be run when installing a system for the first time or in a new location or when installing a KFCU in a STRATA DK16 (if instructions specify).

#### NOTE:

*Program 03 applies to STRATA DK16 only.*

**Program 03—DK16 Flexible PCB Slot Assignments:** This program is used to tell the system's software how the system is configured. The configuration is based on slots, and the system must know what is in each slot. Enter a new code or verify the default code for each slot. (See the PCB Code Reference Table on the Program 0 System Record Sheet.) This Program must be run if the system is being installed for the first time, or when adding a new PCB, or when installing a KFCU (if instructions specify).

For this program's purpose, the Base Key Service Unit is divided into four fixed slots, even though the unit has no slots per se. Slot 0 represents the system's common control (CTU); Slot 01 the Base Unit's eight digital circuits/port (DKU); Slot 02 the Base Unit's four CO line circuits (KCOU); and Slot 03 the optional KSTU PCB in the Base Unit.

The optional Expansion Unit has four slots (04 ~ 07). Unlike the Base Unit, the Expansion Unit's slots are universal. This means that each

of these slots is capable of supporting any of the following PCBs: PDKU, PEKU, PSTU, PESU, PIOUS, KCDU. It is important to note that Slots 04 and 05 are 16 channel slots that are capable of supporting Off-hook Call Announce (OCA) and Data Interface Units (DIUs), whereas Slots 06 and 07 are eight channel slots that cannot support OCA or DIUs. Therefore, we recommend that you install the station PCB in either Slot 04 or 05 rather than 06 or 07. The Expansion Unit can support a maximum of eight station ports and four CO lines.

**IMPORTANT NOTE!**

**After completing Program 03, turn the system power off for five seconds and then turn it back on. This will set in memory all of the configuration data entered in this program.**

**Program 00—Software Check/Remote Maintenance Security Code Assignments:** The RAM checksum, the KPSU Power Cycle Counter, and the system software version can be verified with this program. Neither of these attributes can be changed or edited with this program. **Program 00**, though, does allow two security codes to be set for Remote Maintenance:

- **Level 1 Security Code**—Remote Maintenance security code which allows entry to all programs and data.
- **Level 2 Security Code**—Remote Maintenance security code which allows entry to **Programs 30 ~ 39 and 77 ~ 89.**

**Program 04—Logical Port/Intercom Number Assignment:** Initialized station intercom numbers are 10 ~ 19 (STRATA DK8) or 10 ~ 29 (STRATA DK16), which are assigned to logical ports 00 ~ 09 (STRATA DK8) or 00 ~ 19 (STRATA DK16), respectively. This program can be used to change this initialized setting.

The standard station intercom numbers 10 ~ 19 (STRATA DK8), 10 ~ 29 (STRATA DK16) can be reassigned to different logical port numbers with **Program 04**; or the station intercom numbers can first be changed to numbers other than 10 ~ 19 (STRATA DK8), 10 ~ 29 (STRATA DK16) with **Program 05**, then as-

signed to logical ports with **Program 04**. Station number assignment is fully flexible so that each station can have any intercom number assigned up to four digits. However, **if the first digit is not 1 or 2, access code conflicts may exist**, and a new system numbering plan will have to be carefully worked out—if desired, a digital telephone accompanying a DDSS console (STRATA DK16 only) or Add-on module (DK8 and DK16) can have a station number of 0 or 01, etc. without conflict.

All user guides are written using the standard access codes and station numbers. If no assignment is made in **Program 04**, the system when powered up will automatically assign station numbers as follows:

- For STRATA DK8: The system automatically assigns station numbers 10 ~ 13 to the digital telephone circuit ports in the KSU, station numbers 14 ~ 15 to the first optional CO Line/Digital Telephone Interface Unit (QCDU) PCB (even if it is not installed), station numbers 16 ~ 17 to the second optional (QCDU) PCB (even if it is not installed), and station numbers 18 ~ 19 to the optional Standard Telephone Interface Unit (QSTU) PCB (even if it is not installed).
- For STRATA DK16: The system automatically assigns station numbers 10 ~ 17 to the digital telephone circuit ports in the Base Unit, station numbers 18 ~ 21 to the optional Base Unit Standard Telephone Interface Unit (KSTU) PCB (even if it is not installed), and station numbers 22 ~ 29 to the optional Expansion Unit (even if it is not installed).

**Program 04** does not apply to the door phone standard numbering scheme (551 ~ 556 for STRATA DK8 and DK16), the internal modem (IMDU) number (619) (for STRATA DK16 only), or the Direct Inward System Access (DISA) class of service port (Port 10 for STRATA DK8, Port 20 for STRATA DK16). The system automatically assigns door phone station numbers if a door phone is specified in **Program 77-1**.

**Programs 01 & 02—Logical and Physical Station Port Display:** Logical and physical ports can both be displayed with **Program 01** or **Program 02**. Logical ports cannot be relocated with either of these two programs.

- The logical port associated with a physical port can be verified with **Program 01**. After entering the physical port, the associated logical port will appear on the LCD.
- The physical port associated with a logical port can be verified with **Program 02**. After entering the logical port, the associated physical port will appear on the LCD. See **Program 04's** System Record Sheet for port relocation considerations.

#### **Program 05—Flexible Access Code Numbering:**

The first digit of a feature access code may be changed to a different digit or to two digits. Digits after this prefix cannot be changed. Standard access codes are shown as reference in the **Program 05** System Record Sheet. Some do not change (such as Automatic Callback) and are shown with "N/A" for not affected. **Access code conflicts may exist if new access codes are assigned**; and a new system numbering plan will have to be carefully worked out. Pay particular attention to the internal modem (619) (for STRATA DK16 only) and doorphones 551 ~ 556. Station number assignments may have to be changed using **Program 04**.

**Program 10-1—System Assignments 1:** The following options are available on a system-wide basis.

- **Two CO Conference, LED 20**—Two CO lines can be conferenced with one or two telephones (any type). Conference (LED 19) in this program must be enabled for this feature to work. Also, two CO line conference must be allowed for Direct Inward System Access use of outgoing lines.
- **Conference, LED 19**—The ability of stations to perform any conference can be allowed or disallowed system-wide.
- **Ring Detect Time, LED 18**—This should be set to normal unless connected to Central Office/CENTREX lines that send ring signals less than 120 milliseconds.
- **Intercom Volume PAD, LED 17**—LED 17 ON reduces station to station intercom volume. LED 17 should be OFF in all cases except where extreme quiet room noise is expected.
- **CO Line Dial Pulse Rate, LED 14**—(DK8 only) CO line dial pulse rate can be selected 10 PPS or 20 PPS (See **Program 15** for DK16).
- **Automatic Busy Redial (ABR) Cycles, LED 12**—If activated from a digital or electronic telephone, ABR will retry dialing a telephone number on a CO line if a far end busy signal is detected. The choice is given of retrying 10 or 15 times before terminating. This feature is not available with standard telephones.
- **ABR Redial Time, LED 11**—Upon detection of a far end busy signal on a CO line, ABR will retry either once every 30 seconds or once every minute.
- **System Speed Dial Override, Toll Restriction, LED 10**—System Speed Dial (\*60 ~ \*99) numbers can be set to override Toll Restriction.
- **Exclusive Hold, LED 09**—Exclusive Hold allows electronic and digital telephones to place calls on hold (by pressing the **Hold** button twice) so that other stations cannot pick up the held call with a CO line button. This feature can be disabled on a system-wide basis. Any station can pick up an exclusive hold call by using the call pickup code.
- **Alternate Point Answer/Transfer Privacy, LED 08**—If Transfer Privacy is selected, a transferred call can *only* be answered at the called station upon transfer of that call. With Alternate Point Answer, any electronic or digital telephone with the appropriate CO line button can pick up a call transferred to another telephone. In either case, call pickup will function from any station.
- **Ring Transfer, LED 07**—This option defines station operation for transferring CO line calls. If Ring Transfer is allowed, the system will allow "blind" transfers to busy or idle stations—the transferring station may release a transferred call before the called party answers. If not allowed, the system will allow supervised transfers only—the called station must answer before the transferring station releases. If Ring Transfer is not allowed, immediate recall occurs if "blind" transfer is attempted. Ring Transfer is not allowed to stations in the Do Not Disturb mode; immediate recall will occur if it is attempted.
- **CO Repeat Ringing, LED 06**—If selected, the incoming ringing timing pattern at a station will be the same as the CO line ringing pattern. This is used mainly with



CENTREX or PBX systems which convert the ring pattern to distinguish between intercom and incoming calls, etc. If Standard Ringing is chosen, CO line station ringing will be a 1 second on, 3 seconds off cycle regardless of the incoming ring pattern. Some Central Offices have ringing characteristics which makes this option undesirable.

- **Incoming Call Abandon Timing, LED 05**—The amount of time between incoming CO line ring signals determines when the system will discontinue (abandon) sending ringing tones to stations. The choice of six or eight seconds is dependent on the CO ring pattern. This assignment has no effect if the CO Repeat Ringing (LED 06) option is used.
- **Dual-tone Multi-frequency (DTMF) Signal Time, LED 04**—DTMF signals sent out to CO lines can be either 80 or 160 milliseconds in length. DTMF to QSTU/KSTU/PSTU/PESU ports (including Voice Mail ports) are not affected by this assignment. See **Program 10-2** for QSTU/KSTU/PSTU/PESU DTMF timing. This program also sets the minimum duration of DTMF tones sent by pressing a digit on the dialpad of a 2000-series Digital Telephone—It does not, however, affect the maximum duration; DTMF tones sent by 2000-series Digital Telephones last as long as a dialpad button is pressed.
- **Dial Pulse (DP) Make Ratio, LED 03**—Dial Pulse timing sent out to CO lines can be changed from the normal 40% make ratio to 33%. This selection only applies to those CO lines assigned in **Program 15** to signal dialing with DP instead of Dual-tone Multi-frequency (DTMF).
- **CO Line Reseize Guard Time, LED 02**—This LED should be set for 0.45 seconds for most installations. Set guard time for 1.5 seconds (using **Program 10-1**, LED 02 ON, and **Program 42-0**) if CO lines experience the following situations: no dial tone when a line is released and reseized immediately; or, when operating behind CENTREX or PBX, false hookflash signals are sent to the Central Office when stations release and reseize the same CO line immediately.
- **Tone First/Voice First Signaling-Digital and Electronic Telephone, LED 01**—This

LED sets the signaling method for intercom calls to digital and electronic telephones. With Voice First, an intercom call to an electronic or digital telephone will be preceded by a one second tone burst, followed by voice communication via the Handsfree Answerback function. For Tone First, repetitive intercom ring tone is sent in a one-second on, three-seconds off pattern. Conversion from one form to the other can be made by dialing an additional digit of **1** from the calling station.

**Program 10-2—System Assignments 2:** The following options are available on a system-wide basis.

- **Stations Use External Amplified Conference, LED 19**—This feature should only be used (LED 19 ON) if an external amplifier(s) (**Program 10-3**) is used for two CO line-station conference calls. This will provide additional amplification to the station during the conference call. If an external amplifier is not switched into two CO line conference calls in all cases, LED 19 must be OFF if there is line unbalance which may cause hum noise on the station talk path during two CO line conference calls. For DK8 and DK16, it is recommended to test two CO line conference with LED 19 ON; if there is no hum noise, keep LED 19 ON.
- **Two CO Line Conference, LED 18**—LED 18 should be ON whenever two CO line (Tandem, DISA) connection is allowed in **Program 15-5** and **Program 10-1**, LEDs 19 and 20. This will increase the volume level between the two outside parties on a Tandem (two CO line) connection; but, it will not affect the station volume of any station conferenced into the Tandem connection. This option is not associated with external amplified conference (**Program 10-3**).
- **"TRNS" Soft Key Immediate Transfer, LED 17**—If this feature is activated and a transfer is initiated with the "TRNS" Soft Key on a digital telephone, the call will Ring Transfer (Camp-on) immediately after the last digit of the called (busy or idle) station number is dialed. This feature does not apply to transfers initiated with the **Cnf/T** button or the "CONF" Soft Key.

- **Executive Override Warning Tone, LED 16**—Executive Override allows a station (if assigned in **Program 30**) to break into and overhear an existing station conversation. A warning tone can be set optionally to be heard by the conversing parties.
- **External Page Included with All Call Page, LED 15**—If the all call voice page access code (39) is dialed, external page (all zones) may be included or omitted with this LED option. This option does not affect the **All Call Page** button function, which activates digital and electronic telephone speakers only, never external page.
- **Privacy Override Warning Tone, LED 14**—Privacy Override allows a station to enter into, and overhear, an existing CO line conversation by pressing a CO line button (if the called station is assigned in **Program 30**). A warning tone can be set optionally to be heard by the conversing parties.
- **Auto Callback Camp-on Tone, LED 13**—A busy called digital or electronic telephone user may hear an optional one-time beep tone (from the speaker) signifying that another station has tried to call and has activated the Automatic Callback (ACB) feature.
- **CO Line Beep Tone, LED 12**—If this LED is lit, a beep tone will be sent every three minutes to stations on outgoing CO line calls.
- **Dual-tone Multi-frequency (DTMF) Tone Return, LED 11**—This option can delete DTMF tones that are returned to digital or electronic telephones when manually dialing or speed dialing. It also eliminates auto dial digits returned to callers when digits are automatically sent to voice mail ports on forwarded calls.
- **Background Music (BGM)/Music-on-Hold (MOH) Alternate, LEDs 10 and 9**—An alternate BGM source can be sent to digital telephone speakers, electronic telephone speakers, and external page speakers, while another music source can be sent to outside lines or internal stations on hold (MOH). The BGM source can be connected to a PEKU (Circuit 3), PESU (Circuit 8), PSTU or KSTU (Circuit 4) or QSTU (Circuit 2, Port 19). See **Program 19** for BGM slot assignments for **Table 3**. The MOH source can be connected to the MOH RCA jack on the DK8 K3U or on the DK16 Base Unit.
- **Display Dialed Number Timing, LED 08**—An LCD telephone will display a dialed number for either 15 or 60 seconds before the display changes back to the normal time and date format.
- **Standard Telephone Distinctive Ring, LED 07**—The outside-call ring pattern to standard telephones can be made distinct from the intercom ring pattern. If Distinctive Ring is enabled, the CO-line call ring pattern will be 0.2-seconds on, 0.4-seconds off, 0.2-seconds on, 3.4-seconds off; if Distinctive Ring is not enabled, the pattern will be per **Program 10-1**, LED 06. Intercom calls, with or without Distinctive Ring enabled, ring 1-second on and 3-seconds off.
- **Voice Mail (VM) Identification Code, Dual-tone Multi-frequency (DTMF) Signal Time, LED 06**—DTMF digits that are automatically sent to QSTU/KSTU/PSTU/PESU VM ports can be sent in either 80- or 160-millisecond bursts. This applies to digits sent via voice mail identification code 656/657 set at each station. This program also sets the minimum duration of DTMF tones sent by pressing a digit on the dialpad of a 2000-series digital telephone—It does not, however, affect the maximum duration; DTMF tones sent by 2000-series digital telephones last as long as a dialpad button is pressed.
- **DISA Busy Tone Cadence, LED 05**—Select the busy tone cadence for DISA lines with this LED. Light the LED for a 0.5 second cadence (Bell Precise Busy Tone Cadence); leave it OFF for the STRATA 0.25 second busy tone cadence. The Bell Precise Busy Tone cadence should be selected so callers will know that they have reached a busy station when calling in on a DISA line. If it is not selected, the busy tone may be confused with the reorder tone cadence.
- **Voice Mail (VM) Message Waiting Cancel Via Dial 6 4/Automatic, LED 04**—"Dial 6 4" should be enabled if the DK system is connected to a VM system that sets station Message Waiting (MW) LEDs by dialing **6 3**

- station number. This insures that the message LED remains flashing until all VM messages have been retrieved, at which time the VM machine should cancel the MW LED by dialing **6 4** + station number. With Dial **6 4** enabled, MW indications set on a station from VM ports will not automatically be cancelled by the DK system when the station calls VM to retrieve messages. If "Automatic" is selected, the flashing message waiting LED is canceled any time a station calls the VM machine and the VM machine answers.

**NOTE:**

*Message Waiting cancel via "Dial 6 4 + station number" only applies to VM ports that have LEDs 16 and 17 set "ON" in Program 31.*

- **Ringing Modes, LED 03**—Two choices are available for ringing modes invoked by the Night Transfer button. One choice consists of the DAY, DAY 2, NIGHT modes (three modes), and the other of the DAY and NIGHT modes (two modes). The three-mode selection is useful for alternate answering positions. These modes are switched via the **Night Transfer1/Night Transfer2** button on a telephone or DSS Console (**Programs 29 and 39**) which controls CO line ring assignments (**Programs 78 and 81 ~ 89**).
- **Call Forward Override From DSS Console (DDSS or HDSS) Position, LED 02** (for STRATA DK16 only)—If a station has activated call forwarding, all calls to that station will be forwarded to another number—except for calls from the DSS console position. A choice exists of whether to call forward from the console itself or from the digital or electronic telephone assigned to it. If the console calls (using the DSS console station buttons) are forwarded, the attendant telephone will not be forwarded, and vice versa. This allows the console operator flexibility in reaching a station user.
- **Tone First/Voice First-DSS Console (DDSS/DSS), LED 01** (for STRATA DK16 only)—The intercom call signal from a DSS console can be set for Tone First Signaling or Voice First Signaling, independent of the system-wide signal option set in **Program 10-1**. Thus, DSS consoles and their attendant stations can ring with different signaling modes.

Program 10-3 System Assignments 3. The following options are available on a system-wide basis.

- **LCD BLF Display, LED 20**—Turn LED 20 for LCDs to display port numbers when the Busy Lamp Field (BLF) is activated. LED 20 must be off for LCDs to display default station numbers when the BLF is activated.
- **Speed Dial Entry Timeout, LED 19**—Station users can either have up to one minute or up to three minutes to store Speed Dial numbers or memos, depending on the LED 17 setting. If they fail to store the Speed Dial number or memo within the set time, their station will automatically exit the Speed Dial Storage mode and change to the normal idle state. The three-minute setting is recommended if station users will frequently be storing memos with Speed Dial numbers.
- **QSMU TTY/SMDR Option Select, LED 04** (for STRATA DK8 only)—Selects the function of the QSMU PCB: LED 04 ON—TTY, LED 04 OFF—SMDR.
- **External Amplified Conference, LED 02** (for STRATA DK16 only)—Turn LED 02 on to indicate that an external customer-supplied two-way amplifier is connected to Ports 17 and 18. (These ports must be either PEKU or PESU electronic telephone ports/circuits.) The amplifier will amplify two CO line conference calls. Only one call can be amplified at a time. Conference calls made while the amplifier is in use will not be amplified—See **Program 10-1** (LEDs 19 and 20), **Program 10-2** (LEDs 18 and 19), and **Program 15-5** for more information regarding two-CO line conference.

**NOTE:**

*The external amplifiers will also be automatically switched into two CO line DISA line calls.*

**Program 12—System Assignments-Basic Timing:**

- **Pause Timing, Code 3**—Short and long pauses may be programmed in Speed Dial numbers by station users. The length of short pauses can be set system-wide for either 1.5 or 3 seconds with Code 3. The long pause (a different user selection) is

always 10 seconds. Pause timing applies to Speed Dial on data calls made with Data Interface Units (DIUs), as well as to Speed Dial for regular voice calls.

- **Flash Timing, Code 4**—When on a CO line, a station user can press the **Flash** button and the CO line will open (flash) for a period of either 2 seconds, 0.2 seconds, or 0.5 seconds depending on this assignment mode with Code 4. A flash can also be activated by pressing the **Cnf/Trn** button and dialing **4 5**. In general, this choice reflects whether to disconnect and regain dial tone (2 seconds) or to use PBX or CENTREX features which require a flash signal (0.5 seconds). This flash timing also applies to flashes inserted when dialing via Data Interface Units (DIUs).

**NOTE:**

*The 0.2 seconds option is not normally used in the United States.*

- **Pause After Flash, Code 5**—Some Central Offices or CENTREX facilities require a period of time after a flash signal before they can accept dialing signals. A selection of pause timing can be made with Code 5 to automatically delay any dialing signals after flash. This timing applies to speed dial calls (with flash signals between the telephone number digits) as well as manual dialing.
- **QRCU/K4RCU Seize Time, Code 9**—One channel of the QRCU/K4RCU Dual-tone Multi-frequency (DTMF) receiver/decoder is seized when it is needed for the decoding process, such as with a standard telephone with a DTMF dialpad. When placing outgoing calls with DTMF standard telephones, the talk path to the outside party is not “cut-through” until the QRCU/K4RCU circuit is released. The release time of the QRCU/K4RCU channel can be programmed with Code 9 for a time between one and nine seconds (initialized timing is four seconds); the release time is the time it takes to release the QRCU/K4RCU circuit after the last digit is dialed.

The choice of timing is a trade-off between CO line time to connect and user speed. If the time is too long, the outside called party

may answer before the voice path is “cut-through,” and the caller will not be heard. If the time is too short, a standard telephone user inputting DTMF tones could be cut off prematurely from using other features, such as Speed Dial, or Toll Restriction may be defeated. (To prevent Toll Restriction defeat, force standard telephones to dial outgoing calls via Least Cost Routing (LCR). When dialing via LCR, standard telephones cannot defeat Toll Restriction if the QRCU/K4RCU times out.)

**NOTE:**

*If no digits are dialed after accessing an outside line, the QRCU/K4RCU remains seized for 15 seconds and then drops; however, the CO line remains connected.*

**Program 13—Defining the Message Center:**

Each digital and electronic telephone can receive a maximum of four message waiting indications. One of these four is reserved for the designated Message Center. Typically, the telephone accompanying an Add-On-Module on DK8 or a DSS console (DDSS or HDSS) on DK16 will be the Message Center. However, if incoming traffic to an ADM or a DSS console attendant is heavy, another station may be assigned to be the Message Center.

**Program 15—Assigning Dial Pulse (DP)/Dual-tone Multi-frequency (DTMF), Tenant Service to Individual CO Lines:**

- **Automatic Release (AR) on Voice Mail (VM) Calls, Code 0**—Some Central Offices will send the AR signal—a 95 or 450-millisecond open of the CO line loop—after (typically 1 ~ 15 seconds) an external party hangs up to disconnect the CO line. If an outside party hangs up before or after a VM/auto attendant hookflashes to transfer a call, the Central Office will send the AR signal to the STRATA DK8 or DK16 system, which will then send “D” (Program 31, LED-15) tone to the VM/auto attendant device to release and clear the port for another call.

This feature is active on all voice calls. The LCD of a station which is disconnected from a CO line by the AR signal will display, “CO LINE HANG UP” and the station will receive

return dial tone after seizure, light this LED to insert a pause before and after the PBX or CENTREX access code is dialed by the DIU; LED 05 should also be lit to automatically insert a pause before network telephone numbers are autodialed by DIUs.

**NOTE:**

The pause length is set in **Program 12-3**, and CO lines behind PBX/CENTREX are assigned in **Programs 42-0** and **42-1 ~ 8**.

- **DTR Pulse, LED 06**—If a PDIU-DS is connected to a modem, turn LED 06 ON to cause the modem to disconnect the line when a digital telephone user presses the **Data Release** button. When the button is pressed, the PDIU-DS sends a DTR pulse to the modem, which disconnects the line when it receives the pulse. The PDIU-DS will pulse DTR on outgoing modem calls only—not on incoming modem calls. Initially, the modem should be sent AT command "AT & D2" so it can recognize DTR pulse sent to it by PDIU-DS.

**NOTE:**

It is recommended to change the escape sequence (typically + + +) of a modem connected to a PDIU-DS. Separate sequences will enable users to escape from a modem or a DIU more selectively. Escape sequences are changed with the "ATS2 = \_\_\_" command.

- **Security Groups, LEDs 17 ~ 20**—Data security groups can be set to block data calls between DIUs. DIU users can only make data calls to DIUs in the same security group. LEDs 17 ~ 20 assign the DIU to the appropriate security group: light LED 17 for group 1; LED 18, for group 3; LED 19, for group 2; and LED 20, for group 4.

Typical LED settings for **Program 20**.

- **PDIU-DI(2) Connected to a Terminal or Personal Computer**—LEDs 01, 02, 05, and 17 ON; all other LEDs OFF.
- **PDIU-DS Connected to a Printer**—LEDs 01, 04, and 17 ON; all other LEDs OFF.

- **PDIU-DS Connected to a Modem**—LEDs 01, 02, 03, 04, 06, and 17 ON; all other LEDs OFF.

**Program 21—Modem Pool Port Assignments**

With this program, identify modems connected to standard telephone ports (line side of modem) and PDIU-DS ports (RS-232 side of modem). Each selection pair assigns the modem to the system modem pool. With data security groups (**Program 20**, LEDs 17 ~ 20) and the call blocking feature (**Program 31**, LED 04), modem access can be denied or allowed to data users

**NOTES:**

1. To provide data security for modems, turn ON LED 18 in **Program 31** for standard telephone ports supporting modems. To allow callers to switch from voice to data, turn OFF LED 18 for standard telephone ports supporting modems.
2. Digital telephones with PDIU-DI(2)s that must access modems from a pool require that a **Modem** button be assigned to them in **Program 39**.
3. PDIU-DS ports that are connected to modems in the modem pool should be set with LEDs 01, 02, 03, 04, and 06 ON in **Program 20**.
4. If a modem that is connected to PDIU-DS is also connected to a telephone network CO line, instead of a standard telephone port, **Program 21** should not be used.
5. Use **Program 22** to assign modem/PDIU-DS stations to a hunt sequence.
6. DIUs can be connected to any digital circuit in the DK8 KSU or DK16 Base Unit; or on the QCDU (STRATA DK8), KCDU (STRATA DK16), or PDKU2, but can only connect to Circuits 1 ~ 7 on the PDKU1.

**Program 22—Data Interface Unit (DIU) Station**

**Hunting:** If a DIU station (printer, modem, etc.) is busy, data station hunting allows the data call to that station to hunt to an alternate DIU station assigned in this program. If the hunted DIU station is busy, the system will ring the next "hunt-to" station, and so on. If all DIU stations

the hunt-to sequence are busy, then the data caller will receive a busy tone. It is recommended that all PDIU-DS station ports grouped in a modem pooling or printer pooling/server configuration be placed into a hunt-sequence arrangement with **Program 22**. **Program 22** applies to PDIU-DS and PDIU-DI(2) data stations, not telephone stations. (See **Program 33** for telephone station hunting.)

**NOTE:**

*When a PDIU-DS is connected to a modem assigned to the system modem pool in **Program 21**, modem hunting is automatic when a digital telephone user equipped with a PDIU-DI(2) presses the **DATA** button to transfer a CO line call to a modem; however, if the user dials the modem's PDIU-DS's station number, modem hunting will follow the hunt sequence specified in **Program 22**.*

**Program 28—DSS Console/Attendant Telephone Assignments** (for STRATA DK16 only):

A system configured with just a Base Key Service Unit can support one DSS console; a system configured with the optional Expansion Unit can support up to two DSS consoles. There are two types of DSS consoles: the DDSS console and the HDSS console. A DDSS console can be connected to Circuit 8 of the Base Unit or Circuit 8 of a PDKU. An HDSS console can only be connected to Circuits 7 and 8 of PEKU.

A DSS console can only be associated with just one telephone, but a telephone can have as many as two consoles associated with it. When a DDSS console is connected to the Base Unit, it is automatically assigned to the digital telephone connected to the first digital circuit on the Base Unit. When a console is connected to a PEKU or PDKU in the Expansion Unit, the console is automatically assigned to the telephone that is connected to the first circuit on the PCB. These default assignments can be changed with this program. So, for example, the DDSS console connected to the Base Unit could be assigned to operate with another DSS console and telephone connected to the Expansion Unit.

**Program 29—DSS Console Button Assignments** (for STRATA DK16 only): The buttons on the DSS console (DDSS and HDSS console) may be flexibly assigned as Direct Station Selection (**DSS**) buttons, CO line buttons (**Line** or Speed Dial (**SD**) buttons. The standard equipped **Night Transfer** and **All Call Page** buttons may be changed to either a **DSS**, **Line** or **SD** buttons, but not vice versa. Station Speed Dial buttons assigned to a DSS console share the associated attendant telephone's Speed Dial memory—The Station Speed Dial number of the DSS circuit port(s) are not available. Initialized data assigns the DSS console with 2 **DSS** buttons (for stations 10 ~ 29), 38 **SD** buttons (for Station Speed Dial codes 10 ~ 47), **All Call Page**, and **Night Transfer**. Each of the two possible DSS consoles can be independently programmed.

**Program 30—Station Class of Service:**

- **Privacy Override, LED 19**—Privacy Override allows a station to enter into and overhear an existing CO line conversation by pressing a common CO line button. A maximum of two stations may override an existing station-to-CO line conversation. An optional warning tone may be set—see **Program 10-2**. The choice is for which station allowed to override calls with Privacy Override. Privacy Override of DISA two-CO line calls is not allowed.

**NOTES:**

1. To configure the DK8/DK16 system to operate as nonprivate, allow Privacy Override from all stations.
2. Privacy Override can be blocked by a station via the **Privacy on Line** button (**Program 39**) or by the Executive/Privacy Override blocking option (**Program 31, LED 18**).
3. See Table 2-C at the end of this chapter for more information on Privacy options.

- **Executive Override, LED 18**—Executive Override allows a station to break into and overhear an existing station conversation by

dialing **3** after the busy station number. An optional warning tone may be set—see **Program 10-2**. The option is for which *calling* station can use Executive Override.

**NOTE:**

*Executive Override can be blocked by stations that have Executive/Privacy Override blocking enabled in Program 31, LED 18; the **Privacy on Line** button does not block Executive Override. See Table 2-C at the end of this chapter for more information on Privacy options.*

- **Do Not Disturb (DND) Override, LED 17**—When called, a station with DND activated will return very fast busy tone (four tones per second). If the caller presses the additional digit **2** on the dialpad, a DND Override tone will be heard on the called station's speaker. The assignment is for which *calling* station can use DND Override. Stations must have a **Do Not Disturb** button to activate DND.
- **Toll Restriction/Traveling Class Code Change, LED 16**—If this LED is lit for a port, the station occupying it can change the four digit Toll Restriction/Traveling Class of Service codes established in **Program 44B**. Stations selected for this feature must dial the following sequences to change the codes:
  - Class 1: **Intercom + 6 2 2** + the four-digit code + **Redial**
  - Class 2: **Intercom + 6 2 3** + the four-digit code + **Redial**
  - Class 3: **Intercom + 6 2 4** + the four-digit code + **Redial**
  - Class 4: **Intercom + 6 2 5** + the four-digit code + **Redial**
- **Verified Account Code Change, LED 15**—If selected for this feature, a station can change the Verified Account Codes established in **Program 69**. Selected stations must dial the following sequence to change the codes:
  - Intercom + 6 5 9 + 0 0 0 ~ 2 9 9** + Verified Account Code + **Redial** (on DK16)
  - Intercom + 6 5 9 + 0 0 0 ~ 0 9 9** + Verified Account Code + **Redial** (on DK8)
- **Verified Account Code, LED 14**—If this feature is selected, all Account Codes

Forced or Voluntary, dialed by the station user (or DISA line user) will be Verified per Account Codes set in **Program 69**. If the station user fails to dial one of these specific Verified Account Codes, the call cannot be executed (Forced), or the Account Code will not be validated for the SMDR call report (Voluntary).

- **Handset/Headset Volume Level, LEDs 12 and 13**—This program sets the initial handset and/or headset (off-hook) volume level for each digital telephone. This level can be changed with the digital telephone's volume control button while the handset/headset or headset is off-hook, but it will return to the default level set in this program after the handset/headset is placed on-hook.
  - The volume level range for digital telephone handsets/headsets is 1 ~ 9, with 1 as the lowest. Anytime a handset is off-hook, its volume level can be adjusted anywhere between 1 ~ 9. The level setting established in this program, however, can only be from 2 ~ 5. This level is set with LEDs 12 and 13:
    - For level 5:** Both LEDs ON (High)
    - For level 4:** LED 12, OFF; LED 13, ON
    - For level 3:** LED 12, ON; LED 13, OFF (Initialized setting)
    - For level 2:** Both LEDs OFF (Low)

**NOTE:**

*Program 92-5 (LEDs 01 and 05) does not affect handset/headset receiver volume levels.*

- **Dial Pulse (Dual-tone Multi-frequency Off), LED 11**—If any device connected to a QSTU, KSTU, PSTU, or PESU port does not require the QRCU/K4RCU for DTMF decoding, it should be programmed for dial pulse (DP). When that device goes off-hook, the QRCU/K4RCU will not be accessed, reducing potential traffic to the QRCU/K4RCU.
- **Change Direct Inward System Access (DISA) Security Code, LED 10**—This allows a selected station to change the DISA security code by dialing **Intercom + 6 5 8 + New Code + REDIAL**.
- **Change Toll Restriction Override Code, LED 09**—Two Toll Restriction Override codes are available in the system. When

one of these codes is dialed at any station, all Toll Restriction for that station is bypassed. These codes can be changed only by stations assigned in this program by dialing **Intercom + 6 5 4** or **Intercom + 6 5 5** for codes 1 and 2, respectively.

- **Forced Account Code, LED 08**—If this feature is selected, a station or DISA line user (attempting to make a call on a CO line with Forced Account Code required in Program 15-7) is required to enter an Account Code before a CO line call can be completed. If Forced Account Codes should be Verified, turn on LED 14 in Program 30. The digit length of Forced Account Codes is determined in Program 60-4.
- **Off-hook Call Announce (OCA) Automatic, LED 07**—A busy (off-hook) digital or electronic telephone can receive a second voice communication on intercom via Handsfree Answerback if it is equipped with an OCA subassembly. If a calling station does not have the automatic function, the user must dial an extra digit of **2** or **21** after hearing busy tone in order to gain access to OCA. Initialized data makes all stations automatic for OCA.
- **Automatic Busy Redial (ABR) Access, LED 06**—The ABR feature can be enabled or denied for each station. The system will select the last CO line in the originating line group each time ABR is initiated. If ABR access is denied to a digital telephone station in this program, the "ABR" Soft Key will never appear on the station's LCD. Refer to LEDs 11 and 12 in Program 10-1 for more ABR programming.

#### **IMPORTANT NOTE!**

**For ABR to function, the QRCU (DK8) or the K4RCU (DK16) must be installed to provide busy tone detection.**

- **Microphone (Mic Button) On at Start of Call, LED 03**—The microphone (and Mic button LED) can be selected to be ON or OFF at the start of a call if the Push On/Push Off mode (see "Mic Button Lock," LED 02) is chosen.

#### **NOTE:**

*When receiving intercom calls, the flexible **Microphn Cut-off** button (Program 39) can control the microphone to prevent room monitoring and handsfree answerback.*

- **Mic Button Lock, LED 02**—A digital or electronic telephone microphone can be turned on or off by using the **Mic** button. Two modes of operation are available. A momentary operation requires that the **Mic** button be continuously pressed to disable the microphone. A Button Lock operation allows an alternate action Push On/Push Off of the **Mic** button. LED 02 should be ON if microphone lock operation is desired.
- **Speakerphone Enabled, LED 01**—Any digital or electronic full speakerphone operation can be disabled by assignment with this program. If disabled, a speakerphone will act as a handsfree electronic or digital telephone. Initialized data enables all speakerphones.

**Program 31—Station Class of Service:** This program sets most voice mail (VM) port assignments. Each QSTU/KSTU/PESU/PSTU port connected to a VM device should have the following LEDs turned ON: 04, 05, 09, 15, 16, 17, 18, 19, 20. These LED's should be set ON for VM ports only, not for telephone ports.

#### **NOTE:**

*LED 04 may be ON or OFF, depending on VM device operation. See the LED 04 write up that follows.*

- **VP (B + Station Number), LED 20**—This feature is associated with a VP Digital Voice Messaging System connected to a QSTU, KSTU, PSTU, or PESU port. DTMF "B" tone followed by the station number is sent to VP in situations in which VP would not normally know the location from which a call was coming, such as hold recall or blind ring transfer recall. This allows VP to respond more intelligently with appropriate voice prompts. This LED should be lit for QSTU, KSTU, PSTU, or PESU ports connected to VM devices only, not for station ports connected to telephones.



transferring the call hangs up. When it does hang up, the CO line call will then camp-on to the busy station. The busy station will be alerted of the camp-on by a camp-on tone (five quick tone bursts), the CO line LED will flash at the exclusive hold rate, and a message ("CAMP-ON X", X = the CO line number) will appear on the LCD (if equipped). Among other applications, one in which a VM/auto attendant device that transfers calls to a typically busy answering position station will benefit from this feature—some auto attendant devices cannot transfer a call to a busy station if BST and BSR are not activated.

NOTE:

A BST station will receive ringback tone, instead of busy tone, when transferring a call to a busy BSR station.

- **Automatic Hold, LED 18**—If this feature is allowed, digital and electronic telephone users with CO line buttons can place a CO line or intercom call on hold and call another CO line or station just by pressing another CO line button or the **Intercom** button and dialing the number—there is no need to press the **Hold** button to place the existing call on hold. If Automatic Hold is denied with this LED, users can put calls on hold and place calls, but they will have to press the **Hold** button before accessing another CO or intercom line.

NOTES:

1. CO lines or intercom calls that appear on the intercom button will automatically hold when accessing another CO line button.
2. If Automatic Hold is used, it is recommended to program a **Release Call** button on telephones via **Program 39**.

- **Disable Continuous DTMF tones, LED 17**—Turns off continuous DTMF tones on 2000-series Digital telephones—may be required for PC dialing telephone numbers using PDIU-DI2 connected to a DKT 2000 telephone.
- **No Call Forward/No Answer on Handsfree Answerback Call, LED 16**—A Handsfree Answerback call to an idle station in the Call Forward-No Answer mode or in the Call Forward-Busy/No Answer mode will not forward if this feature is activated. This prevents the call

from being forwarded 12 seconds after the called party has been talking. Outside calls and busy intercom calls to the station will forward even if this feature is set. This feature does not apply to off-hook call announce calls: the called station must answer an OCA call within 12 seconds or the call will be forwarded if CFNA is set.

NOTE:

The caller can press the "RING" Soft Key on a digital telephone or dial 1 on a digital or electronic telephone to activate Call Forward on Handsfree Answerback calls.

- **LCD Individual Message, LED 05**—Turn LED 05 ON to allow stations to store up to ten personal LCD messages. Stations selected with this feature will also be able to assign alphanumeric memos to each of their personal Speed Dial numbers.
- **Message Waiting (RCV), LED 04**—If the message waiting indication is not desired on a digital or electronic telephone, this program can be used to deny it. This does not affect that station's ability to send a message waiting indication to another station.
- **LCD Type/32/12, LED 02**—Digital telephones and 6500-series LCD Electronic Telephones have a 32-character display. Therefore, assignments should be left in the initialized state of 32 characters. LED 02 must be ON to receive a voice mail message waiting indication.
- **LCD Display, LED 01**—This option should be used (LED 01 ON) for all stations (even non-LCD) unless it is desired to disable the station's LCD and message waiting LED function.

**Program 36—Fixed Call Forward:** Fixed Call Forwarding is different from other station Call Forwarding options. It is fixed in terms of the destination station number which is assigned in this program. The station user cannot change this destination as is possible with other station Call Forwarding options. This feature is valuable for forwarding to voice mail devices or to an attendant. If Fixed Call Forwarding is set on a station, the station will not ring and all calls will forward.

**Program 37—Ring Transfer (Camp-on) Recall Time:** If a busy or ringing station does not answer a call sent to it via call transfer, the station originating the transfer will be recalled after a certain amount of time. This time (011 ~ 999 seconds) is set independently for each originating station by this program. Initialized data sets all stations for a 32-second recall time. Ring Transfer must first be enabled for the system with LED 07 ON in **Program 10-1**.

**Program 38—Digital and Electronic Telephone Buttonstrip Type:** Four digital and four electronic telephone button arrangements are provided (see System Record Sheet). It is best to start with one of these four and then move on to **Program 39** where individual buttons may be programmed.

**Program 39—Flexible Button Assignments:** See **Program 38** before running this program. **Program 39** enables each of the flexible feature buttons on digital and electronic telephones to be individually assigned with features. See the **Program 39** System Record Sheet for a complete listing of the available features.

**Program 40—Station CO Line Access:** Any station can have access to as many CO lines as desired. Any station denied access (either to make a call *or* to answer a call) to a CO line cannot seize that line by dialing an access or pickup code or by using a CO line button. This also denies access via Least Cost Routing. Use this program to divide CO lines for Tenant Service. If only *outgoing* access is to be prevented, use **Program 41**. Use **Program 40** to deny CO line call pickup.

**Program 41—Station Outgoing Call Restriction:** Each station (or Direct Inward System Access CO line) can be restricted from outgoing access to each CO line. If so restricted, that station can still answer a ringing CO line or pick up a call on hold. All Call Pickup functions operate normally. This *does not* deny access via LCR. Automatic Busy Redial (ABR) overrides **Program 41**.

**Program 42—CO Line To PBX/CENTREX Connection & PBX/CENTREX Access Codes:** The system recognizes PBX/CENTREX access codes via **Programs 42-1 ~ 8**. **Program 42-0** informs the software which CO lines are con-

ected to a PBX onto CENTREX. This combination allows Toll Restriction and Speed Dialing to function properly. This program must be utilized to allow (after flash) PBX/CENTREX features to operate on incoming calls.

**Program 43—0+ Credit Card Dialing Option:** Selected stations can bypass their normal Toll Restriction assignment by seizing a CO line and then dialing a 0. Both the station and the CO line must be enabled for this feature with this program. After seizing the CO line, the station user is required to dial a specific number of digits, which includes the leading 0. This digit-length requirement forces the user to dial a telephone number or a telephone number plus a credit card number; as a result, these calls are billed to the credit card, and operator-placed calls are not billed to the CO line. The digit length, 1 ~ 30 numbers, is set in **Program 60-7**. This length is determined by the system's call routing method.

- If calls are routed via Least Cost Routing (LCR), the digit length should usually be set at 12, the length, including 0, of the telephone numbers dialed on 0+ credit card calls. Do not add the amount of digits in the credit card (usually 14), although these numbers will be dialed by the user after system LCR seizes the line and the system dials the telephone number (see Important Note).
- When not dialing via LCR, the digit length should usually be 26, the sum of the digits in the telephone (12) and credit card (14) numbers.

**IMPORTANT NOTE!**

***More digits than the length set in Program 60-7 are allowed to be dialed; there is no limit to the amount of digits that can be dialed.***

**Program 44A—Emergency Bypass of Forced/Verified Account Codes:** This program exempts numbers up to four digits, such as the emergency 911 number, from Forced/Verified Account Code dialing restrictions. As many as three of these special numbers can be programmed. When dialed, these numbers will be sent out the CO line immediately, bypassing any

Forced/Verified Account Code dialing restrictions set in **Programs 69** and **30** (LEDs 8 and 14). If CO lines are behind CENTREX or PBX, program the appropriate one-digit or two-digit CENTREX/PBX trunk access code in front of the emergency number. Example: If the PBX trunk access code is 8, then program 8911 in **Program 44A-51** to allow 911 to bypass Forced/Verified Account Code dial requirements.

**NOTES:**

1. If CO lines are behind PBX or CENTREX, program the PBX/CENTREX outside trunk access code. (See **Program 42-0** and **42-1** to assign CO lines and access codes for behind PBX/CENTREX operation.)
2. If Verified Account Codes assigned in **Program 69** conflict (duplicate) with emergency or other type telephone numbers set in **Program 44A**, **Program 44A** has priority.
3. Toll Restriction and Direct Inward System Access (DISA) parameters requirements are not affected by this program.

**Programs 45 ~ 48—Toll Restriction:** All Toll Restriction program information is provided later in this chapter.

**Programs 50 ~ 56—Least Cost Routing:** All Least Cost Routing program information is provided later in this chapter.

**Program 60—Station Message Detail Recording (SMDR) Output/Account Code Digit Length:**

- **SMDR Threshold Time, Item 2**—The time that a call must be in progress before it will register with SMDR can be set to 1 second or 10 seconds. The default is 10 seconds.
- **SMDR Output, Item 3**—System output to an SMDR device can include information for both incoming and outgoing calls, or only for outgoing calls. Local and long distance call data will be sent out.
- **Forced/Voluntary/Verified Account Code Digit Length, Item 4**—The Account Code entered at a station can vary in length from

4 ~ 15 digits. For Forced Account Code a call will not be completed unless the specified number of digits is entered by a station user. With Voluntary Account Codes, the Account Code will not be sent to the SMDR call record unless the specified number of digits are dialed. See **Program 69** for Verified Account Codes.

- **SMDR Printout Options, Item 5**—This option selectively deletes local call data and allows long distance/toll call data only to be sent out the SMDR port. The type of long distance/toll call data that prints out is selected by long distance prefix codes 0, 1, 0 or 1 or 0.
- **Direct Inward System Access (DISA) Security Code, Item 6**—A security code (4 ~ 15 digits) can be required for incoming DISA calls to access outgoing CO lines. If the DISA security code is not set in programming, DISA users can access outgoing CO lines without dialing a security code. The security code is not required for DISA calls to stations. The DISA security code can also be changed from stations enabled in **Program 30**.
- **Credit Card Call Digit Length, Item 0**—Station users bypassing Toll Restriction via the "0+" Credit Card Calling feature (**Program 43**) must dial a predetermined number of digits including the "0." This predetermined number is established with Item 7 and can be 1 ~ 30 digits. **Program 69—Verified Account Codes:** Verified Account Codes may be added, deleted, or changed via **Program 69**. The STRATA DK8 allows a maximum of 100 Verified Account Codes. The Strata DK16 allows a maximum of 300. Each Verified Account Code can be 1 ~ 15 digits long, but cannot exceed the overall Account Code length requirement set in **Program 60-4**. The following programming options should be considered when establishing Verified Account Codes.
- **Account Code Digit Length—Program 60-4** sets the digit length that must be dialed for all Account Codes: Forced (Verified/Nonverified) and Voluntary (Verified/Nonverified).

MARCH 1998

- **Full and Partially Verified Account Codes**—Verified Account Codes can contain the same number of digits (full Verified Account Code) or less (partially Verified Account Code) than the Account Code length set in **Program 60-4**. If partially Verified, the first part of the Account Code is verified and the remainder is not. For example, if Verified Account Code 2734 is set in **Program 69**, but the Account Code digit length is set to eight in **Program 60-4**, then the user must dial 2734 plus any other four digits to enter a partially Verified Account Code. There are many applications for partially Verified Account Codes. For instance, using the code in the example above, the numbers 2734 could be the user's dial restriction code and the remaining four digits could be a customer-client code, a sales order, etc.
- **Verified Account Code Toll Restriction Assignments**—A Toll Restriction class can be assigned with **Program 70** to each of the Verified Account Codes.
- **Verified Account Code Dial Requirement**—The Verified Account Code Dial Requirement is assigned on a station-by-station basis in **Program 30**, LED 14 ON. All Account Codes dialed (Forced or Voluntary) from stations assigned in this program will be Verified.
- **Verified Account Code Change by Station**—Stations selected in **Program 30**, LED 15 ON, can change Verified Account Codes (VAC) by dialing the following sequence:  
**Intercom + 659 + 000 ~ 299 + VAC + Redial**

**NOTE:**

*DK8 provides 100 verified account codes (000-099) and DK16 provides 300 (000-299).*

- **Verified Account Codes: Forced/Voluntary Program Options**—Any station can dial a Voluntary Account Code after accessing a CO line. Forced Account Code requirements are assigned via station and CO line program options: Stations are assigned in **Program 30** (LED 08 ON), and CO lines are assigned in **Program 15-7**. Stations must dial Verified Account Codes when assigned in **Program 30** (LED 14 ON). Direct Inward

System Access (DISA) callers that access outgoing CO lines can be required to enter Verified Account Codes with **Program 30** (LED 08 ON for Port 20).

**Program 70—Verified Account Code Toll Restriction Assignments:** A Toll Restriction class can be assigned with this program to each of the Verified Account Codes assigned in **Program 69**. Therefore, when a Forced Verified Account Code is dialed at a station, the station temporarily assumes the Toll Restriction class assigned to the Verified Account Code. When **Program 70** is initialized, all Verified Account Codes are assigned as not Toll Restricted (data = 00). Verified Account Code Toll Restriction class assignments are not user programmable; so if the assignments are not known, it is recommended to assign a number (block) of Verified Account Codes to each type of Toll Restriction class. For example:

VACs 000 ~ 025 = No restriction  
 VACs 026 ~ 075 = Total restriction  
 VACs 076 ~ 099 = Class 1  
 etc.

**Program 77-1—Peripheral Options:**

- **Door Lock Time, LED 20**—The door lock relay contacts on the PIOU, PIOUS, and Door Phone/Lock Control Unit (DDCB) may be programmed to operate for either three or six seconds.
- **DDCB Port Assignment, LEDs 16 and 17**—Door Phone/Lock Control Unit (DDCB) assignments are defined by this program. DDCBs can *only* be connected to Ports 02 and 03 of the DK8 KSU, or Ports 04 (in the DK16 Base Key Service Unit) and 12 (in the DK16 Expansion Unit). After assigning the DDCB(s), door phone numbers (551 ~ 556 for STRATA DK8 and DK16) will effectively replace the station number assignment(s) in **Program 04**. The door lock option is set via **Program 77-2**.
- **IMDU Modem, LED 14** (for STRATA DK16 only)—Turn LED 14 ON if the optional PIOU or PIOUS PCB will be equipped for Remote Maintenance with the IMDU modem subassembly. The IMDU's station number is 619 (unless the access code prefix has been changed with **Program 05**).

- **Night Ringing over External Page Zones, LEDs 10 ~ 13 (for STRATA DK16 only):** Tenant 1 or Tenant 2 CO lines can be selected with this program to selectively night ring external page zones. For this feature to work, the appropriate CO lines must be programmed to night ring over external page in **Program 78**. Tenant assignments are made in **Program 15**.

**NOTE:**

*The PIOU option PCB must be installed to allow this option.*

- **Door Phone Ring On External Page, LED 08**—If a door phone button is pressed, a ring tone can be enabled or disabled to external paging when the system is in the NIGHT mode. Activation of a **Night Transfer1** button is required for door phones to ring external page. The **Night Transfer2** button does not apply to door phones.
- **PIOU or PIOUS Door Lock Relay/External Page Relay, LED 07 (for STRATA DK16 only)**—A relay on the PIOU or PIOUS can be assigned to operate with the Door Lock function or with External Page for mute control. The door lock button is assigned to telephones in **Program 39**; the door lock activation time is assigned in **Program 77-1**. This door lock control function is not associated with the DDCB door lock control; it is an addition to the DDCB door lock control. If the External Page Relay is selected, Background Music over external page will be muted when an external page is being delivered.

**NOTE:**

*See LEDs 01 and 02 for Base Key Service Unit relay options.*

- **NT Relay Mode Assignment, LED 06**—A relay in the DK8 KSU or DK16 Base Key Service Unit or on the PIOU or PIOUS can be assigned to operate in one of two Night Transfer modes. Before setting the specific Night Transfer mode with LED 06, activate the NT Relay in the DK8 KSU or DK16 Base Unit with LED 01 or activate the NT Relay on the DK16 PIOU or PIOUS with LED 05.

- In one of the modes (LED 06 ON), the relay will activate for one second and then become idle for three seconds when a CO line rings (incoming) and the system is in the NIGHT mode. The relay in this mode is intended for applications where CO Lines are assigned to ring an external ringing device during the NIGHT mode. For this mode to work, Ring Over External Page must be assigned in **Program 78** to CO lines.
- In the other mode (LED 06 OFF), the relay will activate continuously when the system is in the NIGHT mode and the Night Transfer1 (not the Night Transfer2) button is on. One application of this mode is to control an external answering machine.
- **MOH/NT Relay, LED 05 (for STRATA DK16 only)**—A relay on the PIOU and PIOUS can be assigned for Night Transfer applications (see LED 06, "NT Relay Mode Assignment") or for ON-OFF control of a Music-on-Hold (MOH) source, such as a tape player. When the MOH application, the relay will be activated only when a CO line or station is placed on hold.

**NOTE:**

*See LEDs 01 and 02 for DK8 KSU or DK16 Base Key Service Unit relay options.*

- **DK8 KSU or DK16 Base Key Service Unit Relay, LEDs 02 and 01**—The DK8 and DK16 Base Key Service Unit has a relay which can be configured for one of three options: It can be configured to activate a Music-on-Hold source when calls are placed on hold, to mute Background Music (BGM) when an external page is being made, or to control an external answering machine or external ringing device while the system is in NIGHT mode. Select one of the options with the following LED settings.
  - For the External Page option: LED 02 must be OFF. (It does not matter whether LED 01 is ON or OFF.)
  - For the Music-on-Hold activation option: LEDs 01 and 02 must be ON.

- For the NIGHT Relay Mode option, LED 01 must be OFF and LED 02 must be ON. (See LED 06 to specify how the relay will operate when selected for this option.)

**NOTE:**

See LEDs 05 and 07 for DK16 PIOUS and PIOUS relay options.

**Program 77-2—Door Phone Busy/Door Lock Assignments:**

- **Door Phone Ring Count, LED 20**—The number of times that a door phone will ring digital and electronic telephones is set with this LED. Light the LED for one ring; turn off the LED for five rings. The default is five rings. See **Program 79** to assign which digital and electronic telephones will be rung by door phones. Door phones will not ring standard telephones.
- **Door Phone Busy Out, LEDs 01,02, 03, 05, 06, 07**—Each Door Phone/Lock Control Unit (DDCB) can interface with up to three door phones. The system treats each DDCB as a station. Therefore, this is different from station arrangements using telephones. The system does not automatically know how many door phones are connected to each DDCB; so it must be told. This program is used to enter that information so that a caller will receive fast busy tone if the called door phone does not exist. Door phones 1A, 1B, 1C are numbered 551, 552, 553, respectively, and are connected to the DDCB at Port 02/DK8 or Port 04/DK16. Door phones 2A, 2B, 2C are numbered 554, 555, 556, respectively, and are connected to the DDCB at Port 03/DK8 or Port 12/DK16.
- **Door Lock Assignments, LEDs 04 and 08**—Each DDCB B-jack output can be configured as a door lock control. Door lock control buttons for DDCB door locks are assigned to digital or electronic telephones in **Program 39**. Door lock activation time is set in **Program 77-1**. The DK8 supports two door lock (DDCBs) controls, and the DK16 provides a maximum of three door lock controls—one from a DDCB connected to

the Base Key Service Unit, one from a DDCB connected to a PDKU or KCDU in the Expansion Unit, and one from a PIOUS or PIOUS in the Expansion Unit.

**Program 78—CO Line Special Ringing Assignments:**

- **Ring Over External Page During Night Mode, Feature 1**—This program selects which CO lines will activate ringing over external paging facilities during the NIGHT mode.
- **DISA CO Line Assignment, Feature 2**—This program assigns CO lines to be used with the Direct Inward System Access (DISA). CO lines may be set for DISA operation during the different system modes of DAY, DAY2, and NIGHT. A CO line will switch to normal ringing after ten seconds if the outside caller does not use the DISA feature. Normal function of these lines occurs for outgoing calls.

**NOTE:**

An optional security code for DISA outgoing CO calls is available via **Program 60-6**.

- **Ring IMDU Maintenance Modem, Feature 5 (for STRATA DK16 only)**—Remote Maintenance via the optional PIOUS or PIOUS IMDU modem can be accomplished with this program. Different alternatives are available for the system modes of DAY, DAY2, and NIGHT. If none of these are selected, the IMDU can still be reached on station 619 with the DISA feature or by a Ring Transfer from the DSS console attendant or any other station. IMDU station 619 must be enabled with **Program 77-1**. **Program 79—Door Phone Ringing:**
- **Muted Ring to Busy Electronic and Digital Telephone, LED 20**—If all digital and electronic telephones are busy and a door phone button is pressed, a muted ring tone can be sent to selected digital and electronic telephones defined in this program. (Only the lowest port in the appropriate ringing group will mute ring.)
- **Door Phone Ring, LEDs 01 ~ 06**—When a door phone button is pressed, selected digi-

tail and/or electronic telephones assigned in this program will ring. See **Program 77-2** for a description of the door phone A, B, and C numbering scheme. Door phones will not ring standard telephones.

#### **Program 80—Digital and Electronic Telephone**

**Ringling Tones:** Distinctive system ringing sends a different ring tone for CO line ringing than that for intercom ringing. In addition, CO line ringing at digital and electronic telephones can be different from one phone to another. Two choices are available; one is 500 Hz modulated with 640 Hz (PERCEPTION ring tone), while the other is 600 Hz modulated with 800 Hz (STRATA ring tone). Two digital or electronic telephones that are close in proximity can then have distinctive CO line ringing, as chosen with this program.

#### **Programs 81 ~ 89—CO Line/Station Ringing**

**Assignments:** A number of CO line-to-station ringing patterns can be programmed into the system. Nine categories exist, which are DAY IMMEDIATE, DAY DELAY 1, DAY DELAY 2, DAY2 IMMEDIATE, DAY2 DELAY 1, DAY2 DELAY 2, NIGHT IMMEDIATE, NIGHT DELAY 1, and NIGHT DELAY 2. DAY, DAY2 and NIGHT refer to the three modes of the Night Transfer button. DELAY 1 is a 12-second delay of ringing signal to a digital or electronic telephone, and DELAY 2 is a 24-second delay of ringing. The delay functions are mainly used in CENTREX applications but can be used for other situations. If delayed ringing occurs, the station that initially rings will continue to ring with subsequent delayed-ring stations.

**Program 93—CO Line Identification:** This provides alphanumeric names (to appear on LCD telephones) to CO lines, such as "WATS BAND 5," "FX TO NY," "MR JONES," etc. The names may be up to 16 alphanumeric characters each and display when the CO line is being used by an LCD station.

#### **Program 97—Printing Program Data Through Station Message Detail Recording (SMDR):**

Contents of each program can be sent to the SMDR port for a hard copy printout.

**Setting Date, Time and Day:** The current date, time, and day of the week can be set from any LCD digital or electronic telephone connected to Port 00.

## 2 TOLL RESTRICTION

**2.01** The following provides the programmer with an overview of the Toll Restriction feature and step-by-step instructions to fill in the Toll Restriction System Record Sheets.

### 3 TOLL RESTRICTION OVERVIEW

#### 3.00 Toll Restriction Methods

**3.01** Toll Restriction screens and selectively restricts outgoing calls using three different methods. Each type of restriction can be programmed for individual stations. Toll Restriction can also be enabled/disabled for each outgoing CO line in the system.

**3.02 Simple Toll Restriction:** The first method, Simple Toll Restriction, only involves the first digit dialed. The system can be programmed to reject outgoing calls beginning with 0 or 1 (see **Program 48**).

**3.03 Three-digit Toll Restriction:** The second method, Three-digit Toll Restriction, involves the system analyzing the area code dialed, and selectively allowing/disallowing outgoing calls following the criteria defined in Area Code Tables 1 ~ 4 (see **Program 46**, codes 2 ~ 4).

**3.04 Six-digit Toll Restriction:** The third method, Six-digit Toll Restriction, involves the system analyzing the area code and the office code, and selectively allowing/disallowing outgoing calls following the criteria defined in Area Code Tables 1 ~ 4 and Office Code Tables 1 ~ 4 (see **Program 46**, codes 2 ~ 4 and 6 ~ 8).

#### **NOTE:**

*Standard telephones should always be forced to use Least Cost Routing to place outside calls. This prevents Toll Restriction defeat when the QRCU/K4RCU times out.*

#### 3.10 Toll Restriction Features

**3.11** For description purposes, Toll Restriction is divided into several components, or sub-features. The sub-features operate independently of restriction methods just described, although they may employ these methods.

**3.12 Station Priority Classes 1 ~ 4:** Four classes of Toll Restriction can be defined to assign different levels of priority to individual stations. Classes can be defined so each is progressively more restrictive by allowing or denying specific area or office codes, calls to long distance information, international calls, and operator assisted calls (**Programs 46-10 ~ 40**).

**3.13 Office Code Exception Tables:** Class 1 ~ 4 restrictions can be further modified by defining as many as eight exception tables to allow or deny access to specific office codes that fall within previously restricted area codes (**Program 47**). Exception office code access is accomplished with the Six-digit Toll Restriction method described earlier.

**3.14 Emergency, Information, and Toll-free Long Distance Toll Restriction Override:** Toll restricted stations may be allowed to dial special codes such as **911** for emergency response, **1-411** or **411** for information, or 800 prefix toll-free calls (**Program 46**).

**IMPORTANT!**

*Always be sure to provide access to emergency numbers such as 911.*

**3.15 Toll Restriction Override by System Speed Dial:** System Speed Dial numbers can be programmed to override Toll Restriction (see Basic System Features, **Program 10-1**).

**3.16 Toll Restriction/Traveling Class Override Codes:** Up to two Toll Restriction Override Codes can be defined. When dialed at a Toll Restricted station, these codes enable the station user to override Toll Restrictions defined at the station (**Program 44B or 45-8 ~ 9**). Codes may be changed by stations chosen in programming (see Basic System Features, **Program 30**).

**3.17 Special Common Carrier Authorization:** Toll Restriction can be programmed to recognize Other Common Carrier (OCC) telephone numbers, directory numbers, authorization codes, and PBX access codes. The system starts inspecting numbers for Toll Restriction purposes after the recognizable code is dialed (**Program 45-3 ~ 6**).

## 4 COMPLETING THE TOLL RESTRICTION SYSTEM RECORD

**4.01** The following instructions explain how to complete System Record Sheets used to program the Toll Restriction feature. They are arranged in the same order in which the tables appear in the *Toll Restriction System Record Sheets*. The following instructions are intended to give a concise general definition of the programming characteristics defined by each record sheet.

**NOTES:**

1. On each record sheet, mark an X in the space provided to indicate that a choice is selected. Unless otherwise specified, this indicates the LED is lit. When appropriate, indicate digits to be entered using the station dialpad.
2. Initialized data and considerations are documented when applicable.

### 4.10 Program 44B—Toll Restriction/Traveling Class Override Codes

**4.11** Each of the four Toll Restriction classes established in **Program 46** can be assigned a code with this program. If one of these codes is entered at a station, the station will assume the code's class for that call. When the call is complete, the station returns to its regular class assigned in **Program 48**. The traveling class code data is not sent out the SMDR port and will not print out on station call records.

**NOTE:**

*Stations selected in **Program 30**, LED 16 ON, can add, change, or delete the codes set in **Program 44B**. See **Program 30** for more information regarding station revision of override codes.*

### 4.20 Program 45-1—Toll Restriction Dial Plan

**4.21** A dial plan must be defined for the Toll Restriction software to recognize the typical dialing sequence of long distance/local calls made from the system's home area code and to identify area and office codes. The dialing plan defines several components of a telephone number for long distance calling:



- Long Distance Prefix 1—In most areas, a 1 must be the first digit dialed for long distance calling. In such areas, the area code is dialed right away. The dial plan defines whether the prefix 1 is required for a particular installation's long distance calling.
- **Area/Office Code Numbering Schemes**—In most places, the middle digit of an area code is 0 or 1, and the middle digit of an office code is 2 ~ 9. Toll Restriction examines the first three-digit sequence dialed and determines whether it is an area code or an office code.
  - If the middle digit is 0 or 1, then the sequence is an area code.
  - If the middle digit does not equal 0 or 1, then the sequence is an office code, and the office code parameters of the selected dialing plan apply.

**4.22** An exception to this rule exists. In some places, area and office codes are interchangeable. The middle digit is always 0 or 1 (see Code 3 selection). In such a case, the system only knows that three digits dialed are an area code if 1 is dialed before them. If 1 is not dialed first, the system knows the three digits are an office code. The dial plan defines the numbering scheme applicable to the installation site.

- **Office Codes:** Office Code elements are defined as follows:
  - N = 2 ~ 9
  - X = 0 ~ 9
  - NXX = interchangeable with area code; 2nd digit may be 0 or 1.
  - NNX = not interchangeable with area code; 2nd digit may not be 0 or 1.

**4.23** Equal Access Codes and Special Common Carrier Authorization Codes may be entered as exceptions to the dialing plan in **Program 45-3 ~ 6**.

**4.24 Selections:** On the record sheet for **Program 45-1**, choose one of the following dial plans by marking an X in the space next to the code.

- **Plan 1** for dialing plan **AC+NXX/1+NNX** should be selected if the installation is in a location where a user places a long distance call to a destination *outside* the area code without dialing 1 before dialing the area code. The user places a long distance call to a destination in the same area code by dialing 1 directly before the office code.
- When using this plan, the system recognizes the following:
  - The first three digits of a ten-digit number is an area code if the middle digit is 0 or 1.
  - The first three digits dialed immediately after a 1 in an eight-digit string is an interchangeable office code (the middle digit may be 0 or 1).
  - A seven-digit string starting with an office code is a local call.
  - An 11-digit string is not recognized.
- **Plan 2** for dialing plan **1+AC+NXX/1+NNX** should be selected if the installation is in a location where a user places a long distance call to a destination *outside* the area code by dialing a 1 before dialing the area code. The user places a long distance call to a destination in the same area code by dialing a 1 directly before the office code.
- When using this plan, the system recognizes the following:
  - The first three digits following a 1 in an 11 digit number are an area code, if the middle digit is 0 or 1.
  - The first three digits dialed immediately after a 1 in an eight-digit string is an interchangeable office code (the middle digit may be 0 or 1).
  - Digits 5 ~ 7 in an 11-digit string may be an interchangeable office code as well.
- **Plan 3** for dialing plan **1+AC+NXX/NNX** should be selected if the installation is in a location where a user places a long distance call to a destination *outside* the area code by dialing a 1 before dialing the area code. The user places a long distance call to a destination in the same area code by simply dialing the number, without a 1 in front. The area and office codes may be interchangeable. The system differentiates between them whenever it sees the digit 1 dialed.
- When using this plan, the system recognizes the following:
  - If 1 is the first number dialed in an 11-digit string, the next three digits are an area code.
  - A ten-digit string is not recognized.
  - The first three digits in a seven-digit string are an office code. (There is no distinction

between local call dialing and long distance dialing within the area code.)

- Digits 5 ~ 7 in an 11-digit string may be an interchangeable office code as well.
- **Plans 4 and 5** are not used in the United States.

**NOTE:**

*Program 45-1 must be completed for the Least Cost Routing (LCR) feature to function properly. See LCR Program 50-1.*

#### 4.30 Program 45-2—Toll Restriction Disable

**4.31** Selected CO lines may be programmed to be exempt from any Toll Restrictions defined in this section. Mark the exempt CO lines with an X on the record sheet. Initialized data leaves all LEDs OFF, which causes all CO lines to be affected by Toll Restrictions defined.

**NOTE:**

*Toll Restrictions disabled in this program override station Toll Restrictions defined in Program 48.*

#### 4.40 Program 45-3 ~ 6—Equal Access/Special Common Carrier Numbers and Authorization Code Digit Length

**4.41** The purpose of this program is to notify the system of how many digits to ignore before it applies Toll Restriction. This enables the system to allow the use of Special Common Carrier authorization (SPCC) codes.

**4.42** SPCC telephone numbers may be defined to notify the system to modify restrictions when the station user is dialing a long distance carrier. The user dials a code to access the carriers. Original restrictions re-activate after the carrier number is dialed.

**4.43** There are two elements Toll Restriction software must verify for a user to successfully complete long distance calling:

- The first five digits of the number dialed to access the long distance SPCC.
- The total number of digits belonging to the authorization code of the SPCC.

**4.44** Items 3 and 5. Enter the first five digits of the SPCC telephone number in the spaces labeled *SPCC1 Telephone Number* (item 3) or *SPCC2 Telephone Number* (item 5) on the record sheet. The initialized state assigns "00000" to items 3 and 5.

**4.45** **Items 4 and 6:** Enter each SPCC's authorization code digit length. The number of digits allowed (including the first five specified in items 3 and 5) ranges from 00 ~ 99. Initialized data assigns "00" to items 4 and 6. Enter two digits on the record sheet.

**4.46** A restricted station is not able to place a toll call through a long distance carrier by dialing the SPCC1 or SPCC2 telephone number if the station is denied from that number in other toll restriction programs. Upon recognizing the first five digits dialed, Toll Restriction software is notified to allow the number of digits programmed in items 4 or 6 (00 ~ 99, including the first five dialed as SPCC1 or 2).

**4.47** The system interprets data to be a seven-digit local call to an SPCC. Only five digits of the seven-digit number are entered; therefore, the last two digits are don't care digits. Any number dialed that has the same first five digits as the carrier, the system will assume the SPCC is being called.

**IMPORTANT NOTE!**

*For items 4 and 6, do not enter more digits than necessary for the authorization code. If too many digits are allowed, Toll Restrictions may be ignored.*

#### 4.50 Program 45-8 ~ 9—Toll Restriction Override Code

**4.51** Two different codes may be dialed by any station user to override station-specific restrictions.

**4.52** Fill in the codes on the record sheet. They must be four digits each.

**4.53** Selected stations in the system are able to alter the override codes. These stations are assigned in **Program 30**. To change the codes from selected stations:

Code 1: **Intercom + 6 5 4 + code + Redial**

Code 2: **Intercom + 6 5 5 + code + Redial**

#### 4.60 Program 46-2 ~ 4—Toll Restriction Allowed/Denied Area Codes Assigned by Class

**4.61** Four Toll Restriction classes can be defined for the system. Each class area code provides for a different combination of restrictions.

**4.62** This program defines the area codes allowed or denied for each Toll Restriction class. Area code tables for classes 1 ~ 4 can each describe area codes that are allowed or denied for the class. The tables (in memory) operate as allow tables. If an area code exists in a table (displays with 4 #), then it is allowed. Anything not displaying is not allowed. Initialized data allows all area codes for each class (all codes are in all tables). All allowed area codes can be displayed (4 #) for each class.

**4.63** For each class, choose whether the record table is used to record allowed area codes in memory (ALLOWED) or denied area codes not in memory (DENIED). Enter the area codes that define the set.

#### 4.70 Program 46-6 ~ 8—Toll Restriction Allowed/Denied Office Codes Assigned by Class

**4.71** This program defines the office codes allowed or denied for each Toll Restriction Class within the home area code. Office code tables for classes 1 ~ 4 can each describe office codes allowed or denied for the class. The tables (in memory) operate as allow tables. If an office code exists in a table (displays with 8 #), then it is allowed. Anything not displaying is not allowed. Initialized data allows all office codes in the home area code for each class. **4.72** For each class, choose whether the record table is used to record allowed office codes in memory (ALLOWED) or denied office codes not in memory (DENIED). Enter the office codes that define the set.

#### 4.80 Program 46-10 ~ 40—Toll Restriction Class Parameters (Classes 1 ~ 4)

**4.81** This program defines parameters of each Toll Restriction class, including dialing plan restrictions and exceptions to previous restrictions.

**4.82** Toll Restriction exceptions and dialing plan restrictions may be defined for each class. **Program 46-10** assigns class 1 restriction exceptions and parameters; **46-20** assigns class 2; **46-30** assigns class 3; **46-40** assigns class 4. This program also relates to **Program 47**. See **Program 47** for more explanation.

**4.83** To define the proper parameters for a Toll Restriction class, make the appropriate selections on the record sheet designated for classes 1 ~ 4:

- **LED 01: 0 Restricted**—Mark an X next to LED 01 if operator or operator-assisted calls are restricted for the class being defined.

#### **IMPORTANT NOTE!**

*To allow 0 + dialing (LED 01 must be OFF), codes 020 ~ 099 must be allowed in Program 46, and digit free must be allowed in Program 48. Warning—Allowing 0 + dialing also allows operator-assisted toll calls.*

- **LED 02: 01 Restricted**—Mark an X next to LED 02 if overseas operator or unassisted overseas operator calls are restricted for the class being defined.
- **LED 03: 1+AC+555 and AC+555 Allowed**—Mark an X next to LED 03 to allow the particular class to call all restricted area codes plus the office code of 555, including out-of-area directory assistance calls. Turning the LED OFF does not necessarily deny information calls. This may also be accomplished in the office code table and/or the area/office code exception tables.
- **LEDs 11 ~ 18: Area Code/Office Code Exception Tables 1 ~ 8**—Select the exception tables that apply to the class being defined by marking an X in the box. Exception tables for both area and office codes will be defined in **Program 47**.

*NOTE:*

*Each class can be assigned any or all of the eight available office code exception tables.*

**4.90 Program 47—Toll Restriction Exception Office Codes Assigned by Area Codes (Table 1 ~ 8)**

**4.91** This program defines exceptions to previously defined office code restrictions for up to eight area codes, allowing six-digit Toll Restriction. Office codes entered in Tables 1 ~ 8 are opposite of what is defined for the area code by **Program 46-2 ~ 8**. For instance, if **Program 46** denies area code 714, entering office codes **530** and **555** into an exception table for area code **714** will allow those office codes.

**4.92** Eight exception tables are available. Each area code with exception office codes requires a table. Each table may hold up to 800 exception office codes.

**4.93** Enter the area code and required office codes on the record sheet.

**4.100 Program 48—Station Toll Restriction Classification**

**4.101** This program assigns a combination of two restrictions to each station port defined in the system. The first feature is Digit Restriction and the second is Station Restriction Assignment.

**4.102 Digit Restrict Code:** If Digit Restrict is enabled for a particular station, the station is able to dial the number of digits defined in the **Program 45-1** Toll Restriction dialing plan.

- **1: Enable Digit Restriction**—Enter **1** in the Digit Restrict Code column, next to the port number to enable the restriction for the station. This is used to prevent a user from dialing a second call when dial tone is returned from a CO after the outside party disconnects.
- **2: Disable Digit Restriction**—Enter **0** in the Digit Restrict Code column, next to the port number to disable digit restriction for the station. This allows Toll Restricted users to dial any number of digits (i.e., to an external voice mail device, computer, etc.).

**4.103 Station Restrict Code.** The second feature assigns Toll Restriction to individual station ports, in addition to previous restrictions. It includes seven different choices. One of the choices must be entered for each port. Initialized data assigns **0** or no restrictions to all ports. The seven choices are explained as follows.

*NOTE:*

*Station restrictions are overridden by CO lines disabled as defined in **Program 45-2**. If a station port has appearance of a CO line with restrictions disabled, the restrictions will be removed from the station on an individual CO line basis through **Program 45-2**.*

- **0: No Station Toll Restriction**—Enter **0** in the Station Restrict Code column, next to the port number, to remove Toll Restrictions from the station.
- **1: Area Code Toll Restriction**—Enter **1** in the Station Restrict Code column, next to the port number, if the selected station must be restricted from dialing all area codes.
- **2: Area Code Toll Restriction and “0” or “1” as a 1st or 2nd Digit**—Enter **2** in the Station Restrict Code column, in the space available for the port number, if the selected station must be restricted from dialing all area codes, and **0** or **1** when used as a first or second digit. This restriction prevents the station from making any long distance calls or operator-assisted calls, in addition to outgoing calls outside the home area code. In applicable areas, this prevents long distance office codes from being dialed (if 1+NNX).
- **3: Class 1 Toll Restriction**—Enter **3** in the Station Restrict Code column, in the space provided for the port number, if the selected station will be assigned to the Class 1 level of restriction. Class 1 area and office code restrictions are defined in **Program 46** and exception office code tables in **46-10**.
- **4: Class 2 Toll Restriction**—Enter **4** in the Station Restrict Code column, in the space provided for the port number, if the selected station will be assigned to the Class 2 level of restriction. Class 2 area and office code restrictions are defined in **Program 46** and exception office code tables in **46-20**.

- **5: Class 3 Toll Restriction**—Enter 5 in the Station Restrict Code column, in the space provided for the port number, if the selected station will be assigned to the Class 3 level of restriction. Class 3 area and office code restrictions are defined in **Program 46** and exception office code tables in **46-30**.
- **6: Class 4 Toll Restriction**—Enter 6 in the Station Restrict Code column, in the space provided for the port number, if the selected station will be assigned to the Class 4 level of restriction. Class 4 area and office code restrictions are defined in **Program 46** and exception office code tables in **46-40**.

## 5 LEAST COST ROUTING (LCR)

**5.01** The following provides the programmer an overview of the LCR feature and step-by-step instructions to fill in the LCR System Record Sheets.

## 6 LEAST COST ROUTING (LCR) OVERVIEW

### 6.00 Definition

**6.01** The LCR feature enables the system to automatically route each outgoing voice and data call over common carriers and selected CO lines. The customer chooses these lines for the specific time of day and for system users with varying priorities. If the system is programmed properly, LCR can select the most economical route, helping save money. If the best routes are unavailable, users with priority can access more expensive outgoing routes. Figure 2-1 shows a block diagram of LCR operation. Several elements of LCR must be defined in programming.

#### NOTE:

*For LCR to function properly, CO line groups must be created in **Program 16**; CO line restrictions set in **Programs 40** and **41**; and the area dialing plan assigned in **Program 45-1**.*

**6.02 LCR General Parameters.** Enables features including a warning tone for last choice route number, a comfort dial tone during LCR processing, and the Long Distance Information dialing plan.

**6.03 LCR Home Area Code.** Notifies LCR software of the area code of the installation site.

**6.04 LCR Special Codes.** Notifies LCR of special emergency and operator codes that will be automatically routed as a local call, without unnecessary delay.

**6.05 Long Distance Information Plan Number.** Notifies LCR software how to route a long distance information call.

**6.06 Local Call Plan Number.** Notifies LCR software which call routing plan is specifically designed to handle local and special calls.

**6.07 LCR Timeout after 0 (Zero) is Dialed.** Notifies the system of the time delay to the user after dialing a 0, before a regular operator is accessed.

**6.08 LCR Area Codes.** As many as eight separate area code tables can be defined; one for each available call routing plan. Each table defines the area codes that are handled by the particular routing plan.

**6.09 LCR Office Code Exceptions for Area Codes.** As many as eight LCR office code exception tables may be defined to inform LCR software how to handle specific office codes within area codes. According to the tables defined, specific exception office codes can be routed through a different call plan than the overall area code plan.

**6.10 LCR Schedule Assignments.** Call routing plans 1 ~ 8 can send the outgoing calls of different groups of stations according to a time schedule, and call route definitions.

**6.11 LCR Route Definitions.** Groups of CO lines assigned to special common carriers, foreign exchange lines, or other special services can be specified as call routes.

**6.12 LCR Modified Digit Assignments.** Carrier codes can be programmed to dial automatically when a call is placed over the appropriate route. Digits can be added to the front or back of special common carrier codes or other access numbers to make placing calls an invisible process for the

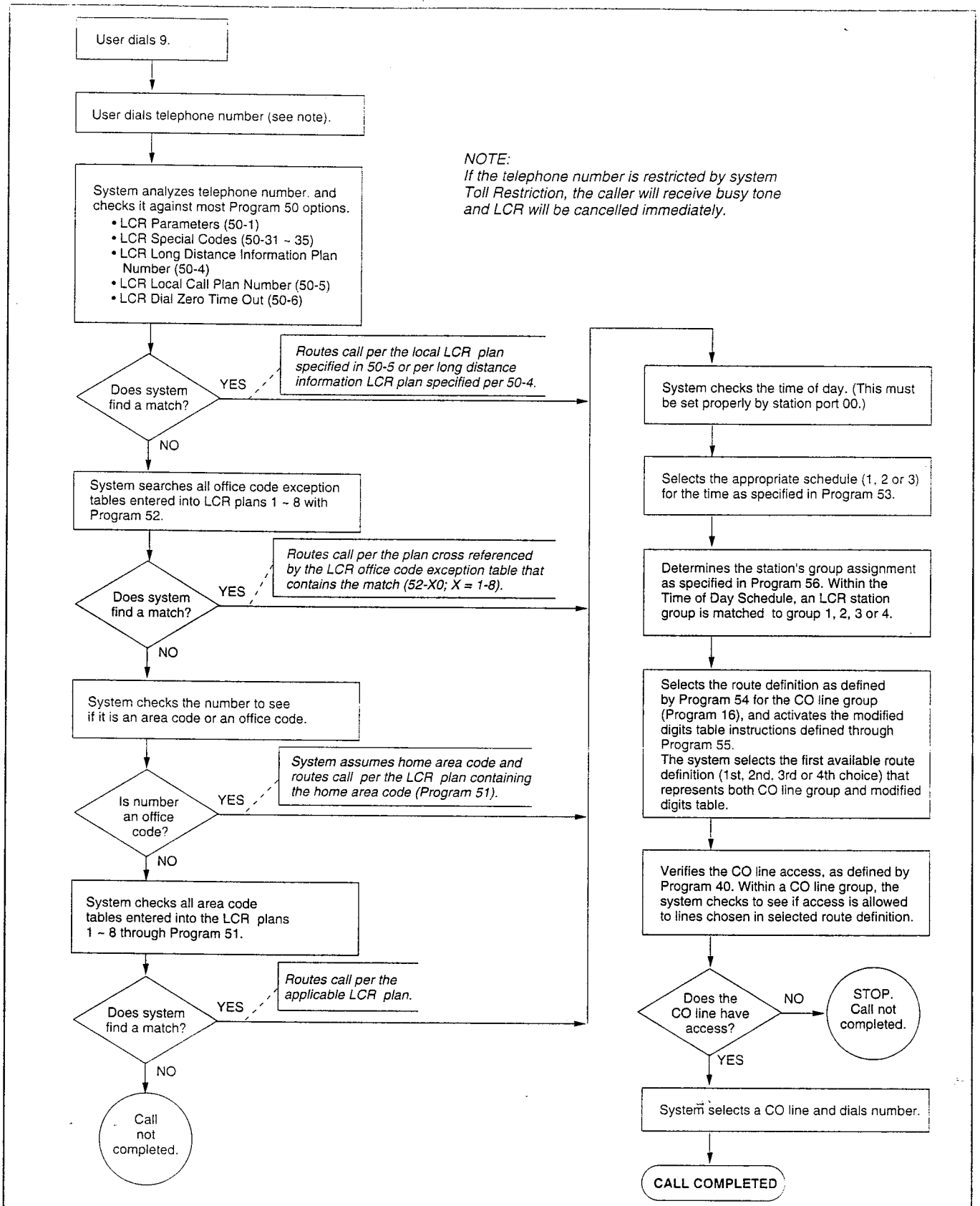


FIGURE 2-1  
 LCR OPERATIONAL BLOCK DIAGRAM

user. Digits may also be deleted from the front of the dialed number.

**6.13 LCR Station Access Priority Assignments.** Each station port defined in the system may be assigned to one of four station priority groups. The groups can have varying access to the defined call routes at different times of day. Each group is partitioned from the other groups.

## 6.20 Conditions

**6.21** A number of conditions apply to LCR assignments. A summary of each is listed here. Paragraph 7, *Completing the Least Cost Routing Record Sheets*, gives more detailed explanations and examples of how the conditions relate to the programming process.

**6.22** If a station has direct CO appearances or pooled CO line buttons programmed to allow direct outgoing line access, LCR will be bypassed using the pooled line or a CO line button.

**6.23** LCR accommodates special code dialing, such as **911** for emergency response, **1-411** or **411** for information, or **800** area code toll-free numbers. These calls can be directed to the local call route. Examples are given in Paragraph 4 (see **Program 50-31 ~ 35**).

### **IMPORTANT NOTE!**

***Always provide emergency service access for numbers such as 911.***

**6.24** Basic System Record programs related to LCR include:

- **Program 16** defines which outgoing CO lines are assigned to CO line groups 81 ~ 88.
- **Program 40** denies a station complete CO line access. This also applies to LCR.
- **Program 41** restricts outgoing CO line calls to selected stations. These stations may make outgoing calls through LCR.

**6.25** Standard telephones that are Toll Restricted should be required to use LCR to place outgoing calls. This prevents Toll Restriction defeat when the QRCU (in DK8) or K4RCU (in DK16) times out.

## 7 COMPLETING THE LEAST COST (LCR) ROUTING SYSTEM RECORD

### **NOTE:**

*All stations using LCR should be ALLOWED CO line access in **Program 40**, and DENIED CO line access in **Program 41**.*

**7.01** The following instructions explain completion of the System Record Sheets used to program LCR. Instructions are arranged in the same order as data tables in the *Least Cost Routing System Record*. The instructions are intended to give a concise, general definition of LCR characteristics defined by each record sheet.

### **NOTES:**

1. *On each record sheet, enter required data in the space provided to make a selection, unless otherwise specified.*
2. *The initialized state and considerations are documented on the record sheet.*

## 7.10 LCR CO Line Programming Reference Chart

**7.11** This chart is intended for reference only. Information relevant to LCR is compiled here from *Basic System Programming*.

- 1) Under the column labeled "CO Lines in Group (01 ~ 08)," enter the numbers of the CO line assigned to groups 81 ~ 84 (for STRATA DK8) or 81 ~ 88 (for STRATA DK16). Refer to the completed record sheet in **Program 1** for this information.
- 2) Under the column labeled "CO Line Type Comments," enter the service type, the common carrier name, or the line type for each line group, e.g., local line, Foreign Exchange (FX) to 818 (LA), WATS (out of state), etc.
- 3) Refer to Basic System Record, **Program 4** to restrict stations from incoming and outgoing access of CO lines, including using LCR. All stations that must use LCR to make outgoing calls must NOT be restricted in the program. These restrictions *do* apply to LCR.

4. Refer to Basic System Record, Program 41, to restrict stations from accessing outgoing CO lines, except through LCR. All stations that must use LCR for outgoing calls must be restricted from CO line access in this program.

## 7.20 Program 50 Series—LCR Definitions

**7.21 Program 50-1—LCR Parameters.** This program defines general operating parameters for LCR software.

*NOTE:*

*Mark an X in the column to indicate which programming button LEDs should be lit. Initialized data leaves all LEDs OFF.*

### LED 01

- **ON:** LCR software is enabled system-wide.
- **OFF:** LCR software is disabled. None of the LCR programming referred to by this section is recognized. Dial 9 access assigned in **Program 16** is enabled.

### LED 02

- Not used.

### LED 03

- **ON:** LCR routes long distance information (LDI) calls over the plan number specified in **Program 50-4**.
- **OFF:** LCR routes LDI calls using area codes specified in route plans 1 ~ 8, as it would for any other call.

### LED 04

- **ON:** Station users hear a simulated dial tone immediately after dialing the access LCR code (typically 9), until the first digit of the phone number is dialed. The dial tone is simulated to assure the user of the system's proper operation, but it is not a functional dial tone.
- **OFF:** Station users hear nothing after dialing the LCR access code until the destination rings or issues a busy signal.

### LED 05

- **ON:** The user is notified with a warning tone to indicate that LCR has routed the call over the least desirable route number. The most expensive route is typically programmed to be the

least desirable. A user has three choices upon hearing the warning tone:

- a) Ignore the tone, LCR places the call using the least desirable route.
- b) Hang up and try later to save money.
- c) Activate the Automatic Call Back feature. The appropriate CO line group calls the user back when a more desirable route number becomes available.

- **OFF:** No warning tone sounds.

## 7.22 Program 50-2—LCR Home Area Code.

Enter the local area code in the spaces provided on the record sheet. Initialized data leaves the home area code blank.

- LCR matches the area code entered here with the LCR route plan containing the home area code in its Area Code Table. (The home area code is later entered into one of the eight available LCR route plans through **Program 51**.) Thus, LCR is informed of how to handle local calls.
- Typically, systems are configured to have the LCR route plan containing the home area code as the same as the local route plan defined in **Program 50-5**. This is typically programmed by the installer to be route plan number 1, rather than the default plan 8.

## 7.23 Programs 50-31 ~ 35—LCR Special Codes.

Five Special Codes may be entered in spaces provided next to 31 ~ 35. The codes may be a maximum of four digits, and should include items such as **911** for emergency calls and **411** or **1-411** for local information, etc. Initialized data leaves all codes blank.

- When any of these codes are dialed, LCR is flagged to treat the call as follows:
  - The call will be sent over the local call route plan specified in **Program 50-5**.
  - No additional digits need to be dialed. They are not necessary. Therefore, the call is put through immediately.

**7.24 Program 50-4—LCR Long Distance Information (LDI) Plan Number.** Enter the number of the LCR route plan (1 ~ 8) over which long distance information calls will be routed. Typically, long distance information calls are routed over the local call route defined in **Program 50-5**.



- If the long distance information plan is chosen in **Program 50-1**, the call is routed as defined by this table.
- Initialized data assigns plan 8 to be the LDI route plan.

**7.25 Program 50-5—LCR Local Call Route Plan Number.** Of the eight route plans available for LCR call processing, one must be defined as the Local Call Plan, typically route plan 1. Enter the number of the plan (1 ~ 8) over which local calls, operator-assisted/0+ calls, and special code calls will be routed.

**7.26 Program 50-6—LCR Dial 0 (Zero) Time-out.** Enter the maximum number of seconds LCR waits for a user to dial additional digits after a 0, before it routes the call to an operator for assistance. LCR will wait this number of seconds to receive additional digits that will indicate charge calls, collect calls or other 0+ calls.

- The allowed range is 04 ~ 10 seconds. Always enter two digits. Initialized data assigns an LCR dial zero time-out value of 06 seconds.

### 7.30 Route Plan Overview

**7.31** Four groups of programs define eight separate LCR route plans. They are **Programs 51 ~ 54**. The purpose of the plan scheme is to provide the system with directions for routing all possible calls, made by all possible users at all possible times of day. Eight separate plans provide the customer flexibility enough to route different area codes and exception office codes over different CO line groups.

**7.32** Initialized data assigns all calls to plan eight. Any assignments made in **Programs 51 ~ 54** for plans 1 ~ 7 will exempt the defined call from being made on route plan 8. Likewise, any phone number not specified in routes 1 ~ 7 automatically defaults to route plan 8.

**7.33** Tables for **Programs 51 ~ 54** appear on LCR Route Plan Numbers 1 ~ 8. The following instructions reveal how to fill in individual tables within the plans. Each of the following program tables must be completed for all plans.

**7.34 Program 51—LCR Area Code Tables.** Every route plan can be assigned to define a set of area codes and/or office codes.

- The purpose of Program 51 is to define what area code calls are placed over which LCR Plan Number (1 ~ 8). Initialized data assigns all possible area codes (000 ~ 999) to LCR Plan 8. Therefore, calls made to all area codes will be routed over route definitions defined in **Program 54** for plan 8, following the time schedule specified by **Program 53** for plan 8 (unless other assignments are made in plans 1 ~ 7).
- For example, any area code entered in a **Program 51** LCR area code table for plans 1 ~ 7 subtracted from plan 8. An area code cannot be lost. If it is subsequently deleted from plans 1 ~ 7, LCR software automatically adds it to plan 8.
- To fill in record sheets for plans 1 ~ 8:
  - Check the box by Area Code Table.
  - Enter the applicable area codes, three digits per box.

**NOTE:**

*Remember that LCR matches the home area code entered in **Program 50-2** with the LCR route plan containing the home area code in its Area Code Table. The home area code must be entered into one of the eight available LCR route plans through **Program 51**. Thus, LCR is informed of how to handle local calls. Typically, systems are configured to have the LCR route plan containing the home area code as the same as the local route plan defined in **Program 50-5**. This usually is programmed by the installer to be route plan number 1, rather than the default plan 8.*

**7.35 Program 52—LCR Office Code Exceptions for Specified Area Code.** The purpose of the Office Code Exception Table is to enable the customer the flexibility of routing specific office codes through a different call plan than other office codes used with that area code.

- Eight LCR office code exception tables may be defined for the overall LCR scheme. Any number of exception code tables may be assigned to each route plan, although each exception table may only be used once system-wide.
- Every route plan can be assigned to define a set of area codes and office code exceptions and a set of office code exceptions.
- This program applies to both examples listed below. In the first case, an office code except

table does not need to be defined in addition to the area codes in **Program 51**, but it may. In the second case, the plan may only pertain to exception office codes for certain area codes.

**Example 1**—In the first example, office code exception tables will be defined to the area code table. Use the continuation sheet to define the exception office codes. As many as eight of the office code exception tables may be linked to a plan, but each exception table may only be used once. When using the continuation sheet, be sure that the same exception table is not assigned to more than one plan.

- Turn to the continuation sheet (that follows plan 8 record sheet).
- Determine the plan number where the exception office codes will be rooted.
- Fill in the area code of the exception office codes in the spaces provided by the correct plan number. These office codes will be routed differently than the overall area code.
- Enter the specific office codes that are to be routed differently.

**Example 2**—In the second example, the route plan only applies to office code exceptions. The first office code exception table may be documented on the LCR Plan record sheet:

- Check the box on the record sheet next to Office Code Exception Table number.
- Enter the number of the exception table (1 ~ 8). Make sure this table number is not entered on any other plan or on the continuation sheet.
- Enter the applicable area code.
- Enter the specific office codes that are to be routed differently than the area code.

**7.36 Program 53—LCR Schedule Assignments.** This program assigns up to three time schedules to each plan. Each time schedule consists of four different route definition choices (defined in **Program 54**) available to the four station groups (defined in **Program 56**). It may be helpful to complete **Program 54** portions of the plans and **Program 56** before proceeding.

**Typical installation without time scheduling feature**—In most cases, an installation will not require use of the time schedule feature. To reflect this on the record sheets for plans 1 ~ 8:

- 1: Enter the same **Schedule Start Times** for **Schedules 1** and **2**. Use military time, in the format HH:MM (Hours:Minutes). Fill in all four digits. Initialized data assigns “0000” to all times.
  - If LCR software sees schedules 1 and 2 have the same start times, then it only looks at schedule 1 for route definitions.
- 2: Enter **Route Definition Numbers** for **Schedules 1** and **2**. Four definitions may be entered for each group.
  - LCR Station (Class) Groups 1 ~ 4 are assigned in **Program 56**.
  - LCR Route Definition numbers 1 ~ 4 are defined in **Program 54**.
  - The order in which the route definitions are entered defines the order of LCR line selection. The most desirable route should be entered in the leftmost position, and the least desirable route in the rightmost position.
  - If “1” is assigned to Station Group 1 and 1 for route definition only, then those assigned will only be able to use route definition 1, thereby restricting them during times that route definition 1 is not allowed.
  - Keep in mind that the route definition number is being entered, not the CO line group number. The definitions are assigned in **Program 54**.

**Installation requiring time scheduling feature**—When an installation requires the time scheduling feature to be programmed, three “shifts” of route definitions can be assigned per station group. To reflect this on the record sheet, substitute Step 1 of the procedure described for the typical customer with the following:

- 1: Enter the **Schedule Start Times** for **Schedules 1, 2** and **3**. Use military time, in the format HH:MM (Hours:Minutes). Fill in all four digits. Initialized data assigns “0000” to all times.
  - Start time for schedule 2 is the stop time for schedule 1.
  - Start time for schedule 3 is the stop time for schedule 2.
  - Start time for schedule 1 is the stop time for schedule 3.

7.37 Program 54—LCR Route Definition: The purpose of this program is to define four different ways of routing calls for each of the eight LCR plans. Define each route by selecting and entering:

1: **CO Line Group (1 ~ 8)**: Refer to the LCR CO Line Programming Reference Chart completed at the beginning of the LCR record sheets.

- Each CO line group represents a type of service, e.g., special common carrier, foreign exchange, local line group, etc.
- **Program 16** assigns CO lines to CO line groups 1 ~ 8 (81 ~ 88).
- **Program 40** denies incoming and outgoing CO line access to stations, including LCR access.
- **Program 41** allows CO line access to stations using LCR only for outgoing calls when enabled.

2: **Modified Digits Table (1 ~ 6)**: Refer to **Programs 55-0, 55-1** and **55-2**. The system handles CO line groups differently, according to which modified digits table was assigned in **Program 54**.

#### 7.40 Program 55 Series—LCR Modified Digits Tables

7.41 This program defines six modified digits tables for LCR call handling. Each modified digits table assigns editing steps that include:

- Deleting a pre-defined quantity of digits from the front of the number dialed (**Program 55-0**).
- Adding a pre-defined number to the front of the number dialed (**Program 55-1**).
- Adding a pre-defined number to the end of the number dialed (**Program 55-2**).

7.42 The purpose of this program is to define call handling so the route definition used by LCR is invisible to the station user. The station user handles all calls the same way. The goal is for LCR to remember the dialing peculiarities of each call route, so the user doesn't need to know.

7.43 **Program 55-0—LCR Modified Digits-Delete**. Enter the **Quantity of Digits** that should be deleted from the front of the number dialed for each of the six **Table Numbers** in the **Delete Digits Table**. The maximum number is ten. Always make the entry two digits.

7.44 **Program 55-1—LCR Modified Digits-Add to Front of Dialed Number**. Enter the digits that must be added to the front of the number dialed in the **Add Digits Table**. The maximum quantity of digits is 22, including pauses.

- Length of pause can be indicated by using codes (P1 ~ P8) specified in the **Pause Entry Reference Table**. Each pause takes two digits of memory space.
- Try to allow for the longest wait, e.g., make the pause longer, rather than shorter, to accommodate the length of time a carrier may need to access the service tones, etc.

7.45 **Program 55-2—LCR Modified Digits-Add to End of Dialed Number**. Enter the digits that must be added to the end of the number dialed in the **Add Digits Table**. The maximum quantity of digits is 22, including pauses.

- Length of pause can be indicated by using codes (P1 ~ P8) specified in the **Pause Entry Reference Table**. Each pause takes two digits of memory space.
- Try to allow for the longest wait, e.g., make the pause longer, rather than shorter, to accommodate the length of time a carrier may need to access the service tones, etc.

7.46 **Program 56—LCR Station Group Assignment**. The purpose of this program is to assign all defined station ports to one of four LCR Station Groups.

- Station groups are completely independent of one another. Therefore, each station group must be defined separately.
- Software does not automatically assign the highest, all-inclusive routing priority to class 1 stations, making all routes available to class 2, 3 and 4 stations available to class 1 as well.
- Instead, stations are assigned to independent groups (partitioned). Completely flexible assignment of routing definitions to groups is allowed, with no one group's definition affecting another's. Each group's route definitions are specified to activate separately according to the time schedules set by **Program 53**.

1: Enter the station group number next to the port number.

# ***Strata***<sup>®</sup> *DK8 & DK16*

## **SYSTEM RECORD SHEETS**

*IMPORTANT INITIAL INSTALLATION NOTES FOR STRATA DK8 AND DK16!*

*These minimum installation steps must be carried out for proper system operation.*

- 1. Set the SW1 switch in the Base Unit ON for BATTERY OPERATION; otherwise, all programmed customer data will be lost on power down.*
- 2. If required, install KSTU and K4RCU in the DK16 Base Unit, or QCDUs, QSTU, QCNU, QRCU, and QSMU in the DK8 KSU.*
- 3. If the DK16 system is configured with an Expansion Unit, follow the order prescribed below:
  - a) Install PDKU, PEKU, PSTU, PESU, or KCDU in Slot 04 of DK16 Expansion Unit.*
  - b) If installing two KCDUs in DK16, install a KCDU in Slot 05. The only PCB allowed in the Expansion Unit with a KCDU PCB is a second KCDU PCB (except for PIOU(S).*
  - c) If the system is configured with a PCOU, install it in Slot 05 in DK16. (The system cannot be configured with both a PCOU and KCDU in the Expansion Unit.)*
  - d) If the system DK16 is configured with a PIOU or PIOUS, install it in Slot 06. (Slot 07 should be reserved for future use.)**
- 4. Initialize Programs 00 ~ 97 by running Program 90 for DK8 and DK16.*
- 5. Run Program 92-1, 2, 3, 4, 5, and 9 for DK8 and DK16.*
- 6. For DK16 installation only, enter the hardware configuration with Program 03, exit the programming mode, turn power OFF for five seconds, then turn power back ON. Program 03 does not apply to DK8.*

*WHEN LATER ADDING DK16 KSU PCBs*

- 1. Turn power off when installing PCBs, then turn power ON.*
- 2. Install new PCBs and set the new configuration with Program 03. (Turn power OFF for five seconds after running Program 03.)*
- 3. Program new features, options, etc., created by new additions.*

*WHEN LATER ADDING DK8 KSU PCBs*

- 1. Turn power off.*
- 2. Install PCB(s).*
- 3. Turn power on.*
- 4. Program new features, options, etc., created by new additions.*

## PROGRAM NUMBER INDEX

FEATURE OR TOPIC	PROGRAM NO.	FEATURE OR TOPIC	PROGRAM NO.
Account Codes	15, 30, 39, 60, 69, 70	Door Lock Control	39, 77-1, 77-2
Alarm Sensor Button (DK16 only)	39	Door Phones	05, 77-1, 77-2, 79
All Call Voice Page	05, 10-2, 31, 39	DSS Console Features (DK16 only)	03, 28, 29-1 ~ 29-2, 10-2
Alternate Point Answer	10-1	DTMF and Dial Pulse Assignments	10-1, 2, 15, 30, 39
Amplified Conference (DK16 )(External)	10-2, 10-3	DTMF Receiver (QRCU/K4RCU) Operation	03, 12, 15
Automatic Hold	35	DTMF Signal Time, CO lines (80/160 ms)	10-1
Automatic Busy Redial	10-1, 16, 30, 39	DTMF Signal Time, VM Ports (80/160 ms)	10-2
Automatic Callback	05, 39, 10-2	DTMF Tone Return	10-2
Automatic Hold Recall	34	Emergency Numbers	44A
Automatic Preference	32	Exclusive Hold	10-1
Automatic Release Hold/VM Port	15	Executive Override	05, 10-2, 30
Background Music	05, 10-2, 19, 39	External Page Interface	10-2, 77-1, 78
Busy Calling/Called Station	35	Fixed Call Forwarding	36, 39
Busy Override	05	Flash Timing	12
Busy Tone Cadence Change	10-2	Flexible Access Code Numbering	05
Busy Station (Trans/Ring)	35	Flexible Button Assignments	38, 39
Call Blocking (VM Ports)	31	Flexible Intercom Numbering	04, 05, 39
Call Forwarding (all types)	10-2, 36, 39	Flexible Line Ringing Assignment	81 ~ 89
Call Pickup	10-1, 15, 39	Flexible PCB Slot Configuration (DK16 only)	03
Call Transfer with Camp-on	10-1	Forced/Voluntary Account Codes	15, 30, 44A, 60, 39
Camp-on	10-1, 37	Group Paging	05, 31
Centrex/PBX Compatible	42-0, 42-1 ~ 8	Handsfree Answerback	10-3, 17, 31
Centrex Ringing Repeat	10-1	Handsfree Answerback (No CFNA)	35
CO/Centrex/PBX Feature Buttons	39, 42-0, 42-1 ~ 8	Hold/Park Recall Timing	34
CO Line Access	39, 40, 41	Initialization (system programs)	90
CO Line Alpha Identification	93	Initialization (system/personal memory)	92
CO Line Groups	16	Intercom Access	39
CO Line Reseize Guard Time	10-1, 42-0	Intercom Number Assignment	04
CO Line Queuing	05, 16	Least Cost Routing	16, 50 ~ 56
CO Line Ringing	78, 81 ~ 89	Liquid Crystal Display Features	10-2, 35, 39
Conferencing	10-1, 15	Logical Ports	01, 02, 04
Credit Card Calls (0 + dialing)	43, 60-7	Message Center	13
Data Port/DIU Configuration	20, 21, 22, 39	Message Waiting/Flash	12, 35, 39
DAY/NIGHT Mode	10-2, 78, 81 ~ 89	Microphone Control	10-3, 30, 39
Delayed Ringing	82, 83, 85, 86, 88, 89	Modem Pool Port Assignment	21
Digital Telephone	03, 30, 38, 92-5	Music-on-Hold	77-1
Direct Inward System Access (DISA)	15, 10-1, 60, 78	Night Pickup Code	05
Direct Station Selection	29-1 ~ 29-2, 39	Night Ringing over External Page	15, 77-1, 78
Distinctive Station Ringing	10-2, 80	Night Transfer	29, 39, 77-1, 78
Do Not Disturb	05, 39	Off-hook Call Announce	03, 30, 31
Do Not Disturb Override	05, 30		

PROGRAM NUMBER INDEX (continued)

FEATURE OR TOPIC	PROGRAM NO.	FEATURE OR TOPIC	PROGRAM NO.
On-hook Dialing	32	Slot Assignment (DK16 only)	03
Outgoing Call Restriction	41, 44-48	Speakerphone Assignment	30
Paging-Digital and Electronic Telephones	31, 39	Speed Dial Timeout	10-3
Passwords-Remote Programming	00	Speed Dial	10-1, 30, 39
Pause Timing	12, 39	Speed Dial Clear	92
PBX Access Code	42-1 ~ 42-8	Standard Telephone Ringing Options	10-2
PBX Backup	42-0	Station Class of Service	30, 31, 35
Physical Ports	01, 02, 04	Station Hunting (Data Calls)	22
Pooled CO Lines	16, 39	Station Hunting (Voice Calls)	33
Pooled Line Buttons	16, 39	Station Message Detail Recording	10-3, 60, 97
Port to Intercom Number Assignment	04	Tandem CO Line Connections	10-1, 10-2, 15
Privacy/Non-Privacy	31, 30, 39	Tenant Service	15, 39, 77-1
Privacy Override	10-2, 30, 31	Toll Restriction	10, 30, 41 ~ 48
Private CO Lines	39	Toll Restriction Override	10-1, 30, 39, 44B
Redial Last Number	39	Toll Restriction Override Code Revision	30
Relay Service	77-1	Transfer Privacy	10-1
Remote Administration and Maintenance	00, 77-1, 78	Traveling Class	44B
Repeat Last Number Dialed	30, 39	Verifiable Account Codes	15, 30, 60, 69, 7
Ringling Line Preference	32, 81 ~ 89	Voice Mail Interface	10-2, 31, 39
Saved Number Redial	39	Voice or Tone Signaling	05, 10-1, 10-2
Security Code (DISA)	30, 60	Volume Reset (Digital Telephones)	92-9
Security Code (R. Maintenance)	00	Voluntary Account Codes	39

TABLE 2-A  
PROGRAMS 00 ~ 97 IN NUMERICAL ORDER WITH SECTIONS CROSS-REFERENCED

Program Number	Title <i>(Applicable Sections)</i>	Program Number	Title <i>(Applicable Sections)</i>
00	<b>Software Check/Remote Password Assignments</b> <i>(Basic System)</i>	22	<b>Data Interface Unit (DIU) Station Hunting</b> <i>(Basic System)</i>
01	<b>Logical Station Port Display</b> <i>(Basic System)</i>	28	<b>DSS Console, Attendant Telephone Assignments (DK16 only)</b> <i>(Basic System)</i>
02	<b>Physical Station Port Display</b> <i>(Basic System)</i>	29-1	<b>DSS Console Button Assignment, DSS Console 1 (DK16 only)</b> <i>(Basic System)</i>
03	<b>Flexible PCB Slot Assignment (DK16 only)</b> <i>(Basic System)</i>	29-2	<b>DSS Console Button Assignment, DSS Console 2 (DK16 only)</b> <i>(Basic System)</i>
04	<b>Logical Port Intercom Number Assignment</b> <i>(Basic System)</i>	30	<b>Station Class of Service</b> <i>(Basic System)</i>
05	<b>Flexible Access Code Numbering</b> <i>(Basic System)</i>	31	<b>Station Class of Service</b> <i>(Basic System)</i>
10-1	<b>System Assignments, Part 1 of 3</b> <i>(Basic System)</i>	32	<b>Automatic Preference</b> <i>(Basic System)</i>
10-2	<b>System Assignments, Part 2 of 3</b> <i>(Basic System)</i>	33	<b>Station Hunting (Voice Calls Only)</b> <i>(Basic System)</i>
10-3	<b>System Assignments, Part 3 of 3</b> <i>(Basic System)</i>	34	<b>Hold/Park Recall Timing</b> <i>(Basic System)</i>
12	<b>System Assignments – Basic Timing</b> <i>(Basic System)</i>	35	<b>Station Class of Service</b> <i>(Basic System)</i>
13	<b>Defining the Message Center</b> <i>(Basic System)</i>	36	<b>Fixed Call Forward</b> <i>(Basic System)</i>
15	<b>Assigning DP/DTMF, Tenant Service to Individual CO Lines</b> <i>(Basic System)</i>	37	<b>Ring Transfer (Camp-on) Recall Time</b> <i>(Basic System)</i>
16	<b>Assigning CO Line Groups (Dial 9 or 81 ~ 88)</b> <i>(Basic System)</i>	38	<b>Digital and Electronic Telephone Buttonstrip Type</b> <i>(Basic System)</i>
19	<b>Alternate Background Music (BGM) Source Slot Assignment</b> <i>(Basic System)</i>	39	<b>Flexible Button Assignments</b> <i>(Basic System)</i>
20	<b>Data Interface Unit (DIU) Configuration</b> <i>(Basic System)</i>	40	<b>Station CO Line Access</b> <i>(Basic System)</i>
21	<b>Modem Pool Port Assignments</b> <i>(Basic System)</i>	41	<b>Station Outgoing Call Restriction</b> <i>(Basic System)</i>
		42-0	<b>CO Line to PBX/CENTREX Connection</b> <i>(Basic System)</i>



TABLE 2-A  
PROGRAMS 00 ~ 97 IN NUMERICAL ORDER WITH SECTIONS CROSS-REFERENCED (continued)

Program Number	Title (Applicable Sections)	Program Number	Title (Applicable Sections)
42-1~8	<b>PBX/CENTREX Access Code</b> (Basic System)	50-1	<b>Least Cost Routing Parameters</b> (Least Cost Routing)
43	<b>0+ Credit Card Dialing Option</b> (Basic System)	50-2	<b>Least Cost Routing Home Area Code</b> (Least Cost Routing)
44A	<b>Emergency Bypass of Forced/Verified Account Codes</b> (Basic System)	50-31~35	<b>Least Cost Routing Special Codes</b> (Least Cost Routing)
44B	<b>Toll Restriction/Traveling Class Override Codes</b> (Toll Restriction)	50-4	<b>Least Cost Routing Long Distance Information (LDI) Route Plan</b> (Least Cost Routing)
45-1	<b>LCR/Toll Restriction Dial Plan</b> (Toll Restriction)	50-5	<b>Least Cost Routing Local Call Route Plan Number</b> (Least Cost Routing)
45-2	<b>Toll Restriction Disable</b> (Toll Restriction)	50-6	<b>Least Cost Routing Dial Zero Timeout</b> (Least Cost Routing)
45-3~6	<b>Equal Access/Special Common Carrier Numbers and Authorization Code Digit Length</b> (Toll Restriction)	51	<b>Least Cost Routing Area Codes</b> (Least Cost Routing)
45-8~9	<b>Toll Restriction Override Code</b> (Toll Restriction)	52	<b>Least Cost Routing Office Code Exceptions for Specified Area Code</b> (Least Cost Routing)
46-2~4	<b>Toll Restriction Allowed/Denied Area Codes Assigned by Class</b> (Toll Restriction)	53	<b>Least Cost Routing Schedule Assignments</b> (Least Cost Routing)
46-6~8	<b>Toll Restriction Allowed/Denied Office Codes Assigned by Class</b> (Toll Restriction)	54	<b>Least Cost Routing Route Definition</b> (Least Cost Routing)
46-10	<b>Toll Restriction Class 1 Parameters</b> (Toll Restriction)	55-0	<b>Least Cost Routing Modified Digits-Delete</b> (Least Cost Routing)
46-20	<b>Toll Restriction Class 2 Parameters</b> (Toll Restriction)	55-1~2	<b>Least Cost Routing Modified Digits-Add</b> (Least Cost Routing)
46-30	<b>Toll Restriction Class 3 Parameters</b> (Toll Restriction)	56	<b>Least Cost Routing Station Group Assignments</b> (Least Cost Routing)
46-40	<b>Toll Restriction Class 4 Parameters</b> (Toll Restriction)	60	<b>Station Message Detail Recording (SMDDR) Output/Account Code Digit Length</b> (Basic System)
47	<b>Toll Restriction Exception Office Codes Assigned by Area Codes</b> (Toll Restriction)	69	<b>Verified Account Codes</b> (Basic System)
48	<b>Station Toll Restriction Classification</b> (Toll Restriction)		

TABLE 2-A  
PROGRAMS 00 ~ 97 IN NUMERICAL ORDER WITH SECTIONS CROSS-REFERENCED (continued)

Program Number	Title (Applicable Sections)	Program Number	Title (Applicable Sections)
70	Verified Account Code Toll Restriction Assignments (Basic System)	84	DAY2 IMMEDIATE Ringing (Basic System)
77-1	Peripheral Options (Door Phones/IMDU/PIOU/PIOUS) (Basic System)	85	DAY2 DELAY1 Ringing (Basic System)
77-2	Door Phone Busy Signal/Door Lock Assignments (Basic System)	86	DAY2 DELAY2 Ringing (Basic System)
78	CO Line Special Ringing Assignments – DISA/IMDU/Night Ringing Over External Page (Basic System)	87	NIGHT IMMEDIATE Ringing (Basic System)
79	Door Phone Ringing (Basic System)	88	NIGHT DELAY1 Ringing (Basic System)
80	Digital and Electronic Telephone Ringing Tones (Basic System)	89	NIGHT DELAY2 Ringing (Basic System)
81	DAY IMMEDIATE Ringing (Basic System)	90	Initializing Program 00 ~ 97 (Basic System)
82	DAY DELAY1 Ringing (Basic System)	92	Initializing Speed Dial Numbers, VM ID Codes, Character Message Memory, Timed Reminder, Digital Telephone Volume, and Call Forward Backup RAM (Basic System)
83	DAY DELAY2 Ringing (Basic System)	93	CO Line Identification (Basic System)
		97	Printing Program Data through SMDR (Basic System)

## IMPORTANT STRATA DK8 AND DK16 PORT INFORMATION

### General

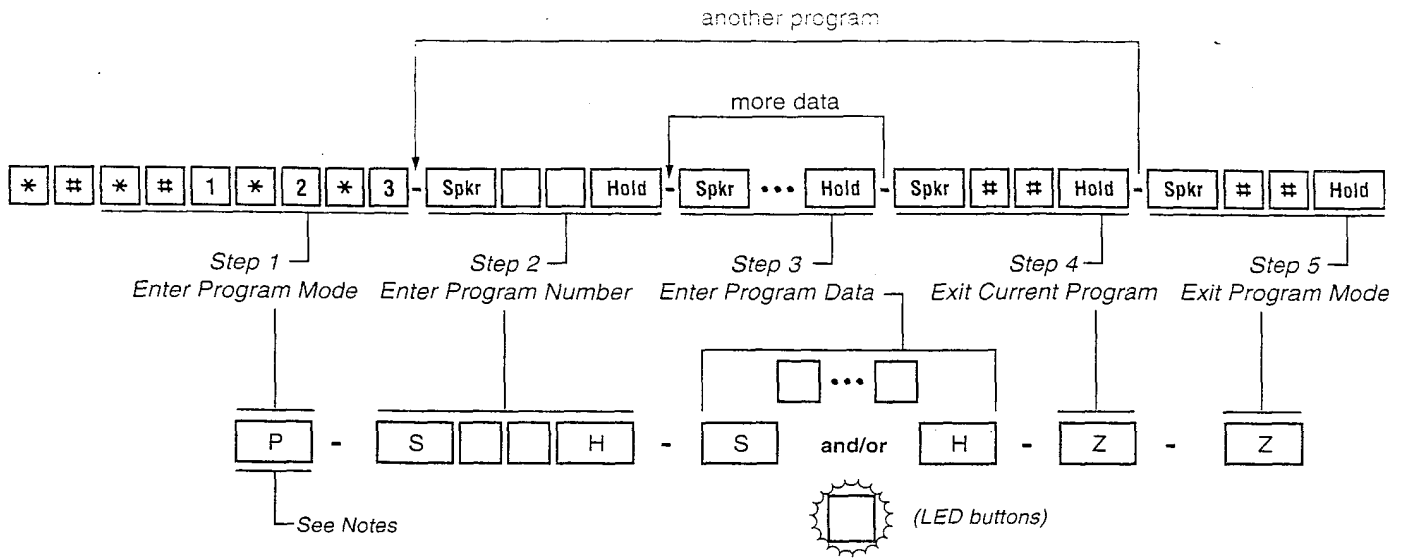
There are two types of ports in the STRATA DK8 and DK16 system: Physical Ports and Logical Port. This distinction of ports gives customers greater mobility in relocating their stations (telephones).

### Physical Ports and Logical Ports

Physical Ports can be defined as the actual system hardware—PCB circuit, wiring, and RJ-11 jack that stations plug into. Logical Ports are attributes associated with a station (telephone)—station interconnect number, Speed Dial numbers, and the complement of features assigned to the station in system software programs. A Logical Port is always associated with a Physical Port.

Physical Ports can be considered as fixed; they cannot be moved unless a PCB is removed from the KSU, Base or Expansion Unit. Logical Ports, though, are not fixed. They can be moved from one Physical Port to another. It is important to note that Logical Ports can only be moved to related Physical Ports. For example, you can move a digital telephone (Logical Port) to another digital Physical Port (circuit), but you cannot move a digital telephone to an electronic telephone circuit Physical Port.

When entering ports into program data, except for **Program 01**, always enter the Logical Port number.



**FIGURE 2-2  
 PROGRAMMING BUTTON SEQUENCE OVERVIEW**

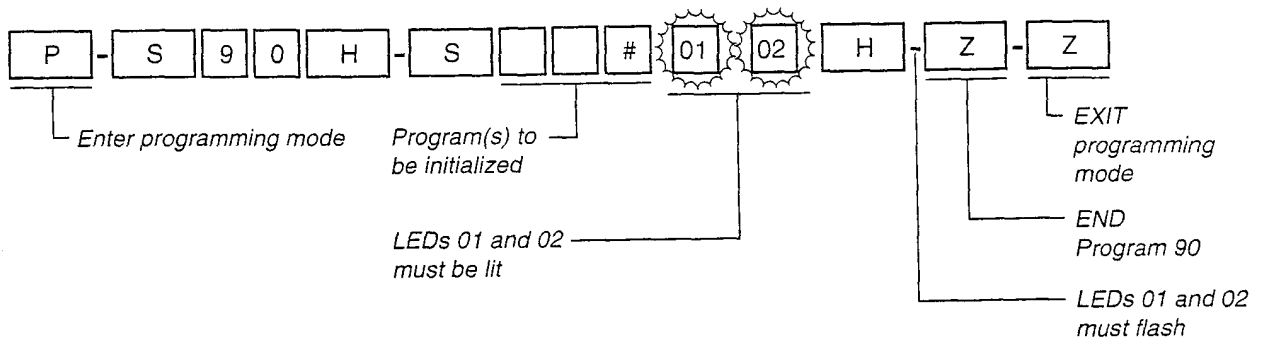
The System Record contains programming forms for **Programs 00 ~ 97**. A System Record should be filled out for each system installed as detailed in Chapters 1 and 2.

Each System Record Sheet is supplemented with a guide at the top of it for entering data from it. The guide illustrates the button sequence a programmer must press, with the exception of sequences common to all programs, e.g., entering programming mode (P), exiting current program (Z), and exiting programming mode (Z). To save space, these common sequences are coded, as illustrated above. The **Spkr** and **Hold** buttons are also coded "S" and "H," respectively, to save space.

**NOTES:**

1. **Programs 90, 92, and 03** are out of order and placed in front purposely because they must always be completed first and in this order. Upon completing these steps, begin with **Program 00**.
2. Do not Press Intercom when entering Step 1.

PROGRAM 90  
 INITIALIZING PROGRAMS 00 ~ 97



**IMPORTANT**

Initialize Programs 00 ~ 97 every time :

- A new system is installed
- To bring a system's programming back to the default setting

Specify the range as follows: 0 0 \* 9 7

To initialize one program at a time, just enter the individual program number, then #.

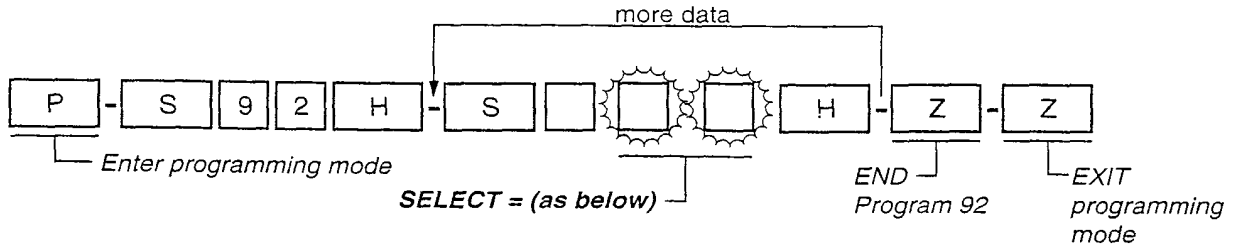
NOTES:

1. Always complete **Program 90** at new system installs, before programming anything else. Skipping this step may cause erratic system behavior.
2. Follow instructions in Table 1-C (Section **100-816-301**) to clear this data.
3. When **Program 90** is run, it will initialize any program or range of Programs without cycling system power.

**WARNING!**

Running this program will erase customer data.

**PROGRAM 92**  
**INITIALIZING SPEED DIAL NUMBERS, VM ID CODES CHARACTER MESSAGE MEMORY, TIMED REMINDERS, DIGITAL TELEPHONE VOLUME, AND CALL FORWARD BACKUP RAM**



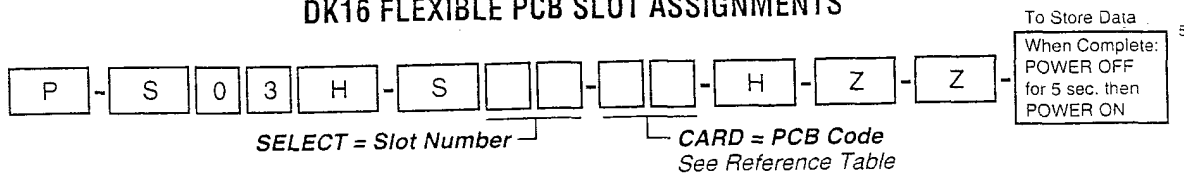
- 1 [01] [03] Clears Station Speed Dial, Voice Mail ID Codes, and LCD memos assigned to Station Speed Dial numbers.
- 2 [01] [04] Clears System Speed Dial and LCD memos assigned to System Speed Dial numbers.
- 3 [02] [03] Clears Character Message Memory (Station and System) and user Name/Number display.
- 4 [02] [04] Clears Timed Reminders.
- 5 [01] [05] Sets speaker volume level to approximately mid-range for intercom tone/BGM, busy override tone (muted ring), and ringing on all digital telephones.<sup>4</sup>
- 9 [03] [04] [H] Power OFF 5 seconds; then Power ON<sup>5</sup> Clears Call Forward Memory and Call Forward indications on telephones.

**NOTES:**

1. **IMPORTANT:** It is mandatory to complete all parts of **Program 92** at every new system install. If **Program 92** is not completed, certain feature operations may cause erratic system behavior.
2. Use the instructions in Table 1-D (Section **100-816-301**) to clear this data.
3. **Program 92-9** does not affect Fixed Call Forward settings.
4. **Program 92-5** does not affect digital telephone handset/headset receiver volume levels. To set off-hook handset/headset receiver volume levels individually for each digital telephone, see **Program 30**, LEDs 12 and 13.
5. Power "OFF" and "ON" is required to clear telephone LCD Call Forward Displays and Call Forward button LEDs. Call Forward memory is cleared when **Program 92-9** is run, even if system power is not cycled.

**WARNING!**  
 Running this program will erase customer data.

PROGRAM 03  
DK16 FLEXIBLE PCB SLOT ASSIGNMENTS



SLOT NO.	BASE UNIT/ FIXED SLOTS				EXPANSION UNIT FLEXIBLE SLOTS			
	00	01	02	03	04	05	06	07
PCB CODE	91 <sup>2</sup>	61 <sup>2</sup>	11 <sup>2</sup>	31 <sup>2</sup>				
PCB TYPE/ FIXED SLOT	Common Control	Digital Ckts	CO Ckts	KSTU				
OPTIONS								
STA. PORT #s	—	00-07 <sup>2</sup>		08-11 <sup>2</sup>				
CO/LINE#s	—		01-04 <sup>2</sup>					

PCB CODE Reference Table		
PCB FIXED SLOT	CODE	PORTS/TYPE
COMMON CONTROL	91	NONE
COMMON CONTROL WITH K4RCU	92	NONE
PIOU/PIOUS	41	NONE
PEKU	21	8/STA.
PEKU W/EOCU	22	8/STA.
PEKU W/DSS	23	8/STA.
PEKU W/EOCU, DSS	24	8/STA.
PESU	25	See Note 3
PESU W/EOCU	26	See Note 3
KSTU AND PSTU	31	8/STA.
BASE UNIT CO CKTs AND PCOU	11	4/CO
BASE UNIT DKT CKTs AND PDKU <sup>4</sup>	61	8/STA.
BASE UNIT DKT CKTs AND PDKU <sup>4</sup> W/DIU or OCA	62	8/STA.
BASE UNIT DKT CKTs AND PDKU <sup>4</sup> WITH DSS (WITH OR WITHOUT DIU OR OCA)	64	8/STA.
KCDU <sup>7</sup>	65	2/CO 4/STA.
KCDU <sup>7</sup> OCA or DIU	66	2/CO 4/STA.
NONE	00	NONE

Slot 04 ~ 06 (Expansion Unit assignment criteria):

- Only one type of station card (except for KCDU) is allowed (maximum); 1-PDKU, or 1-PEKU, or 1-PESU, or 1-PSTU, or 2-KCDUs.
- If KCDU is installed: PDKU, PEKU, PESU, PSTU, or PCOU cannot be installed; PIOU or another KCDU can be installed.
- Station and CO line PCBs should be installed in slots 04 and 05.
- PIOU should be installed in slot 06.
- Slot 07 should be left empty.

NOTES:

1. See instructions in Table 1-E (Section 100-816-301) to input the data from this record.
2. Initialized data.
3. PESU circuits: 1 and 2, standard telephones; 3 and 4, not used; 5 ~ 8, electronic telephones. Total 8 station ports used in software.
4. OCA or PDIU-DI(2)/PDIU-DS will function only with Code 62 or 64 (Base Unit digital telephone circuits and PDKU).
5. System Power **must always** be cycled after running **Program 03**.
6. Off-hook Call Announce (OCA) and Data Interface Units (PDIU-DI(2) and PDIU-DS) will not work in Slots 06 and 07.
7. KCDU does not support DSS connection. PDIU-DI(2)/PDIU-DS or OCA will function with Code 66 only.
8. Digital telephones cannot support OCA and PDIU-DIs/PDIU-DI2s simultaneously.
9. Special PCB codes are not required for ADM or DDCB installation.
10. This program is not necessary for DK8.

PROGRAM 00  
 SOFTWARE CHECK/REMOTE MAINTENANCE SECURITY CODE ASSIGNMENTS



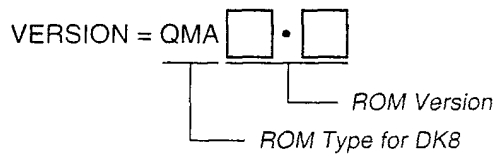
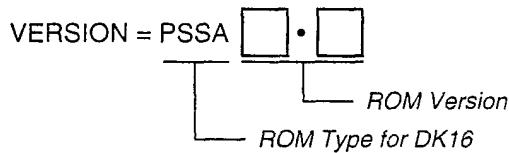
**SELECT = Select Code**  
 Enter 0 to check Software version.  
 Enter 1 to change 1st level password.  
 Enter 2 to change 2nd level password.  
 Enter 8 to check software sum.  
 Enter 9 to check power down or  
 power loss counter since Program 00  
 was last initialized.  
 See Note 3.

**Password Codes**  
 Enter the 4-digit password.

Select Code	Item	Password or S/W Check Codes
0	ROM Version	= VERSION = [ ] [ ] [ ] [ ] • [ ] See Note 4.
1	1st Level Password	= [ ] [ ] [ ] [ ]
2	2nd Level Password	= [ ] [ ] [ ] [ ]
8	Software RAM Checksum	= [ ] [ ] [ ] [ ] [ ] [ ] [ ] [ ] [ ] See Note 5.
9	Power Cycle Counter	= [ ] [ ] [ ] [ ] [ ] See Note 5.

NOTES:

- See instructions in Table 1-F (Section 100-816-301) to program the system with this information.
- Initialized passwords are 0000.
- The LCD responds as follows, when a selection is made:  
 0 Version =  
 1 Password =  
 2 Password =  
 8 Sum =  
 9 Counter =
- This selection is not programmable. It identifies the system's software version as follows:



- These selections are not programmable. They are for factory test purposes only. The Checksum and Counter vary as customer data is entered.



PROGRAM 01  
LOGICAL STATION PORT DISPLAY

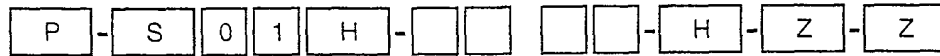


Physical Port  
Enter the Physical Port.  
The port's associated  
Logical Port will appear  
on the LCD.

NOTES:

1. For more information, see the instructions preceding the record sheets.
2. Record port locations on **Program 04** System Record Sheet.
3. Initialized data (**Program 90**) is logical Port No. = Physical Port No.

PROGRAM 02  
PHYSICAL STATION PORT DISPLAY



Logical Port ———  
Enter the Logical Port.  
The port's associated  
Physical Port will appear  
on the LCD.

**NOTES:**

1. For more information, see the instructions preceding the record sheets.
2. Record port locations on **Program 04** System Record Sheet.
3. Initialized data (**Program 90**) is Logical Port No. = Physical Port No.

PROGRAM 04  
LOGICAL PORT INTERCOM NUMBER ASSIGNMENT



SELECT = Logical Port Number

INT = Station Number

NOTE: Shaded areas apply to DK16 only

Logical Ports	Intercom Numbers (Initialized)	Physical Ports (Initialized)	Station Location and Type	Circuit Types
00	(10)	(00)		DK16 — 8-Digit Ports from Base Unit
01	(11)	(01)		
02	(12)	(02)		DK8 — 4-Digital Ports from Main PCB
03	(13)	(03)		
04	(14)	(04)		DK8 — first QCDU
05	(15)	(05)		
06	(16)	(06)		DK8 — second QCDU
07	(17)	(07)		
08	(18)	(08)		4-Standard Telephone Ports from DK16 optional KSTU in Base Unit or 2 Standard Telephone ports from DK8 QSTU.
09	(19)	(09)		
10	(20)	(10)		
11	(21)	(11)		
12	(22)	(12)		8-Universal Ports in optional Expansion Unit. (DK16 only)
13	(23)	(13)		
14	(24)	(14)		Only one type of circuit card allowed:
15	(25)	(15)		1-PDKU, or 1-PEKU, or 1-PESU, or 1-PSTU or 2-KCDU
16	(26)	(16)		
17	(27)	(17)		
18	(28)	(18)		
19	(29)	(19)		

DK16 Expansion Unit Station PCB Type  , Slot No(s) \_\_\_\_\_

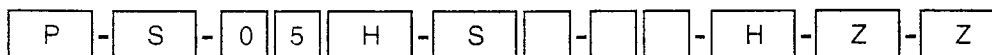
PDKU  , PEKU  , 1st KCDU  , 2nd KCDU  , PSTU  , PESU

NOTE:

Peripheral Device Port Options: Devices other than telephones or Data Interface Units can be connected to the ports listed below. If a peripheral device is connected to a Physical Port, the Logical Port must have same port no. as the Physical Port.

- Port 00 – **DK16** — Digital telephone associated with DSS Console.
- Port 02 and 03 – **DK8** — Digital Door Phone/Lock Control Unit (DDCB).
- Port 04 – **DK16** — Digital Door Phone/Lock Control Unit (DDCB).
- Port 07 – **DK16** — Digital Direct Station Selection Console (DDSS).
- Port 10 – **DK8** — DISA Port number used for Toll Restriction Class and Verified/Forced Account Code assignment.
- Port 11 – **DK16** — Separate Background Music Source (KSTU required in Base Unit).
- Port 12 – **DK16** — Digital telephone associated with DSS Console (PDKU/Expansion Unit required) or DDCB.
- Port 12 – **DK16** — Electronic telephone associated with DSS Console (PEKU/Expansion Unit required).
- Port 14 or 19 – **DK16** — Separate Background Music Source (PEKU, PESU, or PSTU/Expansion Unit required).
- Port 17 & 18 – **DK16** — PESU or PEKU ports connected to external amplifier to provide external amplified conference and /or DISA.
- Port 18 & 19 – **DK16** — Electronic Direct Station Selection console (HDSS) (PEKU/Expansion Unit required).
- Port 19 – **DK16** — Digital Direct Station Selection console (DDSS) (PDKU/Expansion Unit required).
- Port 20 – **DK16** — DISA Port number used for Toll, Class and Verified/Forced Account Code assignments.

PROGRAM 05  
FLEXIBLE ACCESS CODE NUMBERING



*SELECT = Access Code 1-9  
from the Table Below*

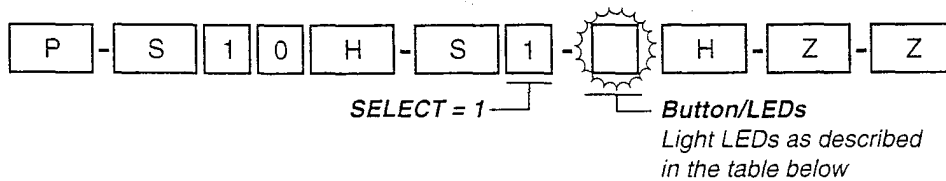
*SPECIAL DIAL = New Access Codes  
See Note 6 Below.*

Access Code	Features Affected (N/A = Not Affected)	New Access Codes
0	Unused	
1	Voice First/Tone First (N/A)(1) Station LCD Messages (10 ~ 19)	Station Intercom Numbers (N/A) (10 ~ 19) Station Speed Dial Set (10 ~ 49)
2	Busy Override (N/A) (2) Do Not Disturb Override (N/A) (2)	Station Intercom Numbers (N/A) (20 ~ 29) <sup>7</sup> Off-hook Call Announce (N/A) (2)
3	Executive Override (N/A) (3) All Call Voice Page (30) All Call Voice Page with External Spkrs (39)	External Page Zones(35 ~ 38) <sup>7</sup> Group Page (Internal) (31 ~ 34)
4	Automatic Callback (N/A) (4) CO Line Queuing (N/A) (4) Station Number Display (401) Port Number Display (402) Hold/Park (41) Hold/Park Pickup (42) Automatic Busy Redial (44) Automatic Busy Redial Cancel (44) Message Waiting Answer (408)	Flash (45) Account Code Input (46) T.R. Override/T. Class Code Input (47) BGM Over Stations - ON (481) BGM Over Stations - OFF (480) BGM Over External Speakers ON (491) BGM Over External Speakers OFF (490) Cancel Message Waiting at Station (No MW button) (409)
5	Voluntary Account Code (*50) Door Phones (551 ~ 556), Call Pickup: • Station (5+Station No.) • Ringing CO Line (59)	• Telephone Page (530) • Directed Pickup of CO Line on Hold (57 <input type="checkbox"/> <input type="checkbox"/> , <input type="checkbox"/> <input type="checkbox"/> = 01 ~ 08 for <b>DK16</b> , 01 ~ 04 for <b>DK8</b> ) • External Page (531, 535 ~ 538)
6	Auto Relocation ON (6282) Auto Relocation OFF (6281) Auto Relocation Special Dial ON (6283) Auto Relocation-Special Dial Disconnect (626) Auto Relocation-Special Dial Connect (627) Call Forward (601, 602, 603, 604) Timed Reminder (605 ~ 609) MW for Voice Mail ON (63+Station No.) MW for Voice Mail OFF (64+Station No.) Voice Mail ID Code Set (Call Fwd, 656) Voice Mail ID Code Set (Ans. MW, 657)	LCD Message Set (68) DKT Mute Ring Adjust (6101) DKT Ring Level Adjust (6102) IMDU Access (619) <sup>7</sup> Date Set (651) Time Set (652) Weekday Set (653) T.R. Override Code Change (654, 655) System Speed Dial/LCD Messages (60 ~ 99) LCD User Name (621-Set, 620-Reset) DISA Security Code Change (658) Verified Account Code Change (659) Traveling Class Code 1 ~ 4 Change (622 ~ 625)
7	CO Outgoing Calls (701-708 for <b>DK16</b> or 701 ~ 704 for <b>DK8</b> ) Message Waiting Set/Cancel (N/A) (7) (77)	
8	CO Group Outgoing Calls (81 ~ 88 for <b>DK16</b> or 81 ~ 84 for <b>DK8</b> )	
9	Least Cost Routing or CO Group (9)	

**NOTES:**

1. For more information, see the instructions preceding the record sheets.
2. Be sure access code changes do not conflict with existing access code or station numbering schemes. Refer to **Program 04** - Port/Station Number Assignment.
3. To insert a blank, press programming Button/LED 01.
4. If access codes are being changed to a number that is currently assigned, change the currently assigned code to an unused code first. In the initialized state, the only unused code is zero (0).
5. The initialized station number sequence of 10 ~ 29 may not be globally changed through **Program 05**. Make changes through **Program 04**.
6. The first digit of an access code can be replaced by 2 digits. Standard Access codes are shown for reference.
7. Applies to **DK16** only.

PROGRAM 10-1  
SYSTEM ASSIGNMENTS, PART 1 OF 3

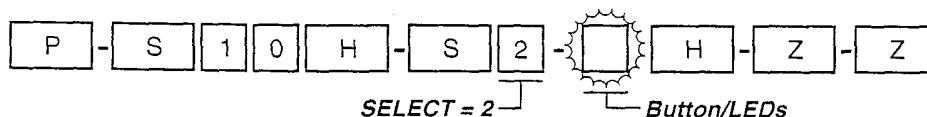


Button/LED	X	LED On	LED Off
20	2	Two CO Conference/Allowed <sup>6</sup>	Not Allowed
19	2	Conference/Allowed	Not Allowed
18	2	Ring Detect Time - Normal	Ring Detect Time - Short Rings
17		Intercom Volume PAD (-8 dB)	No Intercom PAD
16		-	-
15		-	-
14 <sup>8</sup>		CO Line Dial Pulse Rate; 20PPS	CO Line Dial Pulse Rate; 10PPS
13		-	-
12		ABR Cycles/10 times	15 times
11		ABR Redial time/30 sec.	1 min.
10		System Speed Dial Override Toll Restriction	Restricted
09	2	Exclusive Hold/Allowed	Not Allowed
08	2	Alternate Point Answer	Transfer Privacy
07 <sup>4</sup>	2	Ring Transfer of CO Lines Allowed	Not Allowed
06 <sup>5</sup>		CO Repeat Ringing	Standard Ring
05		Incoming Call Abandon/8 sec.	6 sec.
04 <sup>3</sup>		CO DTMF Signal Time/160 msec.	80 msec. <sup>3</sup>
03		DP Make Ratio/33%	40%
02 <sup>7</sup>		0.45 or 1.5 sec. per Program 42-0	CO line re-seize guard time 0.45
01		Tone First (from DKTs/EKTs)	Voice First (from DKTs/EKTs)

NOTES:

1. For more information, see the instructions preceding the record sheets.
2. Initialized data lights LEDs 07, 08, 09, 18, 19, and 20.
3. LED 04 DTMF Signal Time applies to manual and Speed Dial tones sent out of the system via CO lines. LED 04 **does not** apply to Call Forward or voice mail ID DTMF tones sent to voice mail ports. (See **Program 10-2**, LED 06, for tones sent to voice mail ports.)
4. If Ring Transfer is allowed, set Ring Transfer Recall time in **Program 37**; if ring transfer is not allowed (LED 07 off), the station will recall immediately if transfer is attempted.
5. Standard ring pattern is 1 sec. on, 3 sec. off.
6. Two CO conference must be allowed for DISA operation.
7. CO line guard time is the time interval the system requires to release a CO line and allows it to be re-seized. If LED 02 is off, all lines are set with 0.45 second guard time; if LED is on, guard time is 0.45 or 1.5 seconds per **Program 42-0**.
8. This option selects CO line dial pulse rate for DK8 only, see **Program 15-2** to select DK16 dial pulse rate.

**PROGRAM 10-2  
SYSTEM ASSIGNMENTS, PART 2 OF 3**



Light LEDs as defined by the table below.  
ALL LEDs with an "X" should be lit when you finish

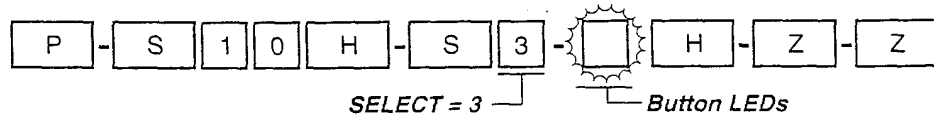
NOTE: Shaded areas apply to DK16 only

Button/LED	X	LED On	LED Off
20		-	-
19 <sup>10</sup>		Station External Amp Conference	No External Amplifier Connected
18		Two CO Line Conference	No Two CO Line Conference
17		"TRNS" Immediate (Soft Key)	"TRNS" Normal (Soft Key)
16	<sup>2</sup>	Executive Override Warning Tone/ON	Executive Override Warning Tone/OFF
15 <sup>6</sup>	<sup>2</sup>	External Page included with All Call Page	Not Included
14	<sup>2</sup>	Privacy Override Warning Tone/ON	Privacy Override Warning Tone/OFF
13		Send Auto Callback Camp-on Tone <sup>3</sup>	No Callback Tone
12		CO Line 3 min Beep Tone	No Beep Tone
11		No DTMF Tone Return <sup>7</sup>	DTMF Tone Return
10 <sup>4, 11</sup>		BGM connected to QSTU (DK8), PORT 19; PESU (DK16), Circuit 8 <sup>9,10</sup>	Telephone connected to CKT
09 <sup>4</sup>		BGM connected to PEKU, Circuit 3 <sup>9,10</sup>	Telephone connected to CKT
08		Display Dialed Number/1min.	Display Dialed Number/15 sec.
07 <sup>5</sup>		Standard Tel., CO Ring per Prog. 10-1, LED 06	Standard Tel. CO Ring Distinctive
06		VM ID Code DTMF Signal Time 80 ms	160 ms
05		DISA Busy Tone, 0.5 second cadence <sup>8</sup>	DISA Busy Tone, 0.25 second cadence
04		MW cancel from VM; dial <b>6 4</b> & Station No.	MW cancel from VM: Automatic
03		Ringing Modes/3	Ringing Modes/2
02	<sup>2</sup>	Hunt/C.F. override from DSS console's phone	Hunt/C.F. override from DSS console
01		Tone First (from DSS Console)	Voice First (from DSS Console)

**NOTES:**

1. For more information, see the instructions preceding the record sheets.
2. Initialized data lights LEDs 02, 14, 15 and 16.
3. Called party receives notification tone when calling party activates Automatic Callback.
4. BGM connected to QSTU/PSTU/PEKU/PESU/KSTU, will be sent to electronic and digital telephone speakers and external page (optional). Important: Power must be turned off and on for BGM assignments to be effective.
5. Ring pattern for standard telephones: distinctive ring on incoming CO calls, is: 0.2 sec. on, 0.4 sec. off, 0.2 sec. on, 3.4 sec. off; intercom ring is always 1 sec. on, 3 sec. off. This doesn't apply to voice mail ports (Program 31, LED 17 on) which are always standard ring.
6. External speakers and designated digital and electronic telephones are paged by dialing **Intercom 3 9**. The **All Call Page** button is used only to page designated digital and electronic telephones.
7. Deletes DTMF tones returned to digital and electronic telephones when dialing from dialpad or speed dialing; also deletes auto dial digits sent to callers that are call forwarded to voice mail. This does not affect the actual DTMF tones sent out to the CO or voice mail.
8. 0.5 second cadence. Bell Standard Busy Tone, should be enabled so outside callers are not confused by STRATA 0.25 second busy tone when calling busy number on DISA line calls.
9. If BGM source is assigned to KSTU or PSTU slot in Program 19, system automatically assigns KSTU or PSTU CKT 4 as a BGM source.
10. **Important:** LED 19 should be OFF unless external amplifiers are used for two CO line/station conference (see Program 10-3). If LED 19 is ON, the station may be unbalanced and receive HUM if external amplifier with Auto-Gain-Control is not connected.
11. BGM connected to QSTU, circuit 2, (DK8) Port 19 may require an isolation transformer per Section 100-816-207

PROGRAM 10-3  
SYSTEM ASSIGNMENTS, PART 3 OF 3



Light LEDs as defined by the table below.  
ALL LEDs with an "X" should be lit when you finish.

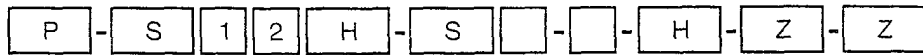
NOTE: Shaded areas apply to DK16 only

Button/LED	X	LED ON	LED OFF
20		LCD BLF Displays Port Numbers (00 ~ 19, <b>DK16</b> ) or (00 ~ 09, <b>DK8</b> )	LCD BLF Displays Station Numbers (10 ~ 29, <b>DK16</b> , 10 ~ 19, <b>DK8</b> )
19		Speed Dial Entry Timeout: 3 minutes	Speed Dial Entry Timeout: 1 minute
18			
17			
16			
15			
14			
13			
12			
11			
10			
09			
08			
07			
06			
05			
04 <sup>6</sup>		QSMU Option: TTY	QSMU Option: SMDR
03			
02 <sup>3, 4, 5</sup>		PEKU/PESU Ports 17, 18 — Amp. Circuits 6 and 7	Ports 17,18 — Stations Connected
01			

NOTES:

1. For more information, see the instructions preceding the record sheets.
2. Initialized data: all LEDs off.
3. See Section 100-816-208 for connecting two-way amplifiers for use on tandem, DISA, and conference telephone calls.
4. See Program 10-2 (LEDs 18 and 19), Program 10-1 (LEDs 19 and 20), and Program 15-5 for more information regarding two CO line conference/tandem.
5. The amplifier, which is switched to two CO line calls automatically, is accessed on a first-come-first-serve basis. Two CO line calls established while the amplifier is already being accessed will not be amplified.
6. QSMU option is for DK8 only.

### PROGRAM 12 SYSTEM ASSIGNMENTS - BASIC TIMING



**SELECT = 3-9**  
Enter program code,  
3 ~ 9, from table below.

**SELECT CODE =** Enter required  
code for the time listed in the  
table below. See Note 3.

Program Code	Function	Time	Required Code
3 <sup>6</sup>	Pause Timing (Speed Dial)	<div style="border: 1px solid black; display: inline-block; padding: 2px;">1</div> 1.5 sec. <div style="border: 1px solid black; display: inline-block; padding: 2px;">2</div> 3.0 sec.	
4 <sup>6</sup>	Flash Timing <sup>4</sup>	<div style="border: 1px solid black; display: inline-block; padding: 2px;">1</div> 0.5 sec. <div style="border: 1px solid black; display: inline-block; padding: 2px;">2</div> 2.0 sec. <div style="border: 1px solid black; display: inline-block; padding: 2px;">4</div> 0.2 sec. <sup>5</sup>	
5	Pause After Flash (Voice Path Delay)	<div style="border: 1px solid black; display: inline-block; padding: 2px;">0</div> no pause <div style="border: 1px solid black; display: inline-block; padding: 2px;">1</div> 1.5 sec. <div style="border: 1px solid black; display: inline-block; padding: 2px;">2</div> 3 sec.	
9	QRCU or K4RCU Inter-digital Release Time (Standard Phone)	<div style="border: 1px solid black; display: inline-block; padding: 2px;">1</div> 1 sec. through through <div style="border: 1px solid black; display: inline-block; padding: 2px;">9</div> 9 sec.	

**NOTES:**

1. For more information, see the instructions preceding the record sheets.
2. Initialized data programs timing as follows: Code 3 = 1, Code 4 = 2, Code 5 = 0, and Code 9 = 4.
3. When programming Code 9, the LCD responds with "LINE TIME =" instead of "SELECT CODE =".
4. The duration of time the CO line circuit opens Tip & Ring when the **Flash** button is pressed or when the hookflash code **Cnf/Trn 4 5** is dialed.
5. This timing is not normally used in the United States.
6. This timing applies to voice calls originated from telephones and voice or data calls originated by Data Interface Units, PDIU-DI(2)s or PDIU-DSs.



PROGRAM 13  
DEFINING THE MESSAGE CENTER

P	-	S	1	3	H	-	S	1	-			H	-	Z	-	Z
---	---	---	---	---	---	---	---	---	---	--	--	---	---	---	---	---

SELECT = 1

PORT = Logical Port Number  
Enter the Logical Port number  
of the station to be defined  
as the Message Center.

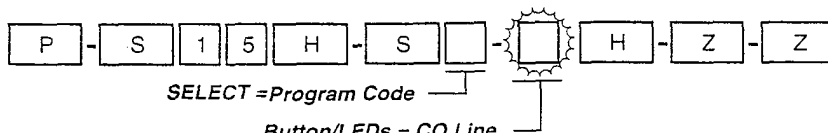
Port  
Number

--	--

NOTES:

1. For more information, see the instructions preceding the record sheets.
2. Any electronic or digital telephone may receive (and store) up to 3 message waiting indications from any other digital or electronic telephone. A fourth message waiting indication may be set by the Message Center, which can only be a voice mail device or a digital or electronic telephone.
3. The Message Center is allowed to perform "Message Waiting," even if disallowed on all other stations.
4. Initialized data = no port assigned.
5. The message center feature should be assigned to the customer's main answering position: a station or the lowest port (in the voice mail group) of the customer's voice mail device (see **Program 31** for voice mail group port assignment), whichever the customer specifies.

## PROGRAM 15 ASSIGNING DP/DTMF, TENANT SERVICE TO INDIVIDUAL CO LINES



Specify CO lines by setting LEDs, as defined by the table below.  
All LEDs with an "X" should be lit when finished.

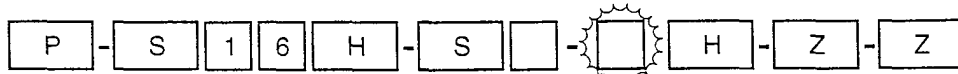
NOTE: Shaded areas apply to DK16 only

Program Code	Program	LED Status		CO Lines 01 ~ 08 (Button/LEDs)							
		ON	OFF	01 (01)	02 (02)	03 (03)	04 (04)	05 (05)	06 (06)	07 (07)	08 (08)
0	AR VM Calls/D Tone <sup>3,6,7,8</sup>	Detect	Ignore								
1	CO Outgoing Signal <sup>5</sup>	DP	DTMF								
2 <sup>9</sup>	CO Dial Pulse Rate (Pulse per sec.)	20 PPS	10 PPS								
3	AR Hold/Ring Transfer <sup>3,8</sup>	Detect	Ignore								
4	AR Timing <sup>3</sup>	Crossbar 95 msec.	ESS (Electronic) 450 msec.								
5	Tandem CO Line Connection with Station Dropout <sup>4</sup>	Equipped	Not Equipped								
6	CO Line Tenant Assignment	Tenant 2	Tenant 1								
7	Forced Account Code	Equipped	Not Equipped								
8	Operation After Flash	No QRCU after flash	QRCU/K4RCU after flash								

**NOTES:**

1. For more information, see the instructions preceding the record sheets.
2. Initialized data is all LEDs Off.
3. AR = Automatic Release signal. This is a momentary open of the CO line loop provided by **some** Central Offices. If programmed to recognize AR, CO lines on-hold will drop when the outside party hangs up and the CO sends AR signal. Two CO line DISA calls always release with AR. DISA line release is not related to this program—DISA calls always release with AR signal. AR is sometimes referred to as "Calling Party Control" or "Supervised Loop Control."
4. Tandem connection must be equipped for all DISA CO lines and all other lines used for two CO line conference.
5. If a CO line is set for Dial Pulse (DP) operation, the Tone Dial Select button must be programmed on stations that must send DTMF tones over the CO lines. (See **Program 39** to assign feature buttons.)
6. When AR is sent on a CO line call because the outside caller hangs-up, "D" tone will be sent to the voice mail (VM) port (QSTU/PSTU/PESU/KSTU), prompting the VM machine to release and clear the port for another call.
7. The system will detect the AR signal (auto release) and drop the voice mail port when the outside caller hangs up. (See Note 3 for AR explanation.)
8. If the CO line is enabled to detect AR, the CO line will disconnect anytime during a call if the Central Office sends the AR signal. If AR is sent when talking on a CO line with an LCD telephone, the LCD will display, "CO LINE HANG UP."
9. See **Program 10-1**, LED 14, to select DK8 dial pulse rate.

PROGRAM 16  
ASSIGNING CO LINE GROUPS (DIAL 9 OR 81 ~ 88)



**SELECT = CO Line Group**  
Only enter the last digit of  
the CO line group (1 ~ 8) to  
be defined, or enter 0 for Dial 9 group.

**Button/LEDs**  
Specify which CO lines are assigned to the  
group by setting LEDs as defined by the table  
below. All LEDs with an "X" should be lit  
when finished. See Note 2.

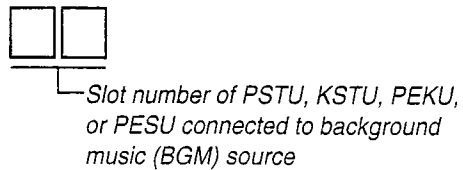
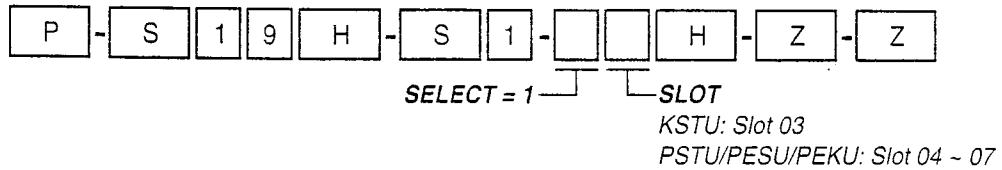
NOTE: Shaded areas apply to DK16 only

LED	CO Line	CO Line Groups								
		81 (1)	82 (2)	83 (3)	84 (4)	85 (5)	86 (6)	87 (7)	88 (8)	Dial 9 (0)
08	(08)									
07	(07)									
06	(06)									
05	(05)									
04	(04)									
03	(03)									
02	(02)									
01	(01)									

NOTES:

1. For more information, see the instructions preceding the record sheets.
2. Initialized data assigns all CO lines to the Dial 9 group.

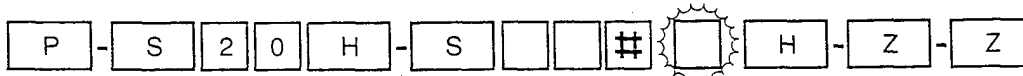
PROGRAM 19<sup>8</sup>  
 DK16 ALTERNATE BACKGROUND MUSIC (BGM) SOURCE SLOT ASSIGNMENT



NOTES:

1. For more information, see the instructions preceding the record sheets.
2. If PEKU, the BGM source must be wired to Circuit 3. (Program 10-2.)
3. If PESU, the BGM source must be wired to Circuit 8. (Program 10-2.)
4. If KSTU or PSTU, the BGM source must be wired to Circuit 4 and may require an isolation transformer per Section **100-816-207**.
5. If connecting the source to a PEKU or PESU, turn on LED 09 or 10 in **Program 10-2**. If connecting BGM to a KSTU or PSTU, LEDs 09 and 10 in **Program 10-2** do not apply.
6. The PDKU and the KCDU will not support a BGM source.
7. Initalized Data is "BLANK". Press Button/LED 01, to enter BLANKS.
8. Alternate BGM source is assigned to DK8 QSTU, Port 19, using Program 10-2, LED 10. Program 19 is not necessary for DK8.
9. System power must be cycled for this program to take effect.

PROGRAM 20  
DATA INTERFACE UNIT (DIU) PORT CONFIGURATION



Select = Logical Port Number that is connected to PDIU-DS or to DKT with PDIU-DI(2).

Button/LEDs 1 ~ 5 defines data port type: Button/LEDs 17 ~ 20 assigns data port to security group.

Port Number

Port Number

Port Number

LED	X	LED ON	LED OFF
20		Data Security Group 4	Not Included
19		Data Security Group 2	Not Included
18		Data Security Group 3	Not Included
17		Data Security Group 1	Not Included
16			
15			
14			
13			
12			
11			
10			
09			
08			
07			
06		DTR Pulse With <sup>5</sup> Data Release	No DTR Pulse
05		Auto Pause <sup>3</sup> Behind PBX	No Auto Pause
04		PDIU-DS Connected	PDIU-DI(2) <sup>6</sup> Connected
03		PDIU-DS to Modem Connection	PDIU-DS to other type DCE or DTE
02		AT Commands and Result Codes	AT Dial Command Only
01		DIU Connected	No DIU Connected

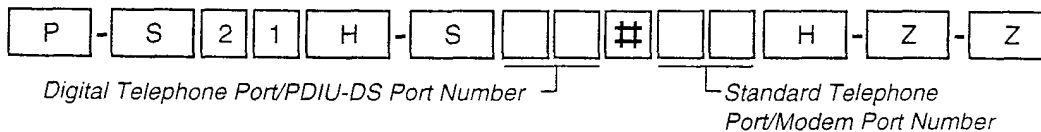
LED	X	LED ON	LED OFF
20		Data Security Group 4	Not Included
19		Data Security Group 2	Not Included
18		Data Security Group 3	Not Included
17		Data Security Group 1	Not Included
16			
15			
14			
13			
12			
11			
10			
09			
08			
07			
06		DTR Pulse With <sup>5</sup> Data Release	No DTR Pulse
05		Auto Pause <sup>3</sup> Behind PBX	No Auto Pause
04		PDIU-DS Connected	PDIU-DI(2) <sup>6</sup> Connected
03		PDIU-DS to Modem Connection	PDIU-DS to other type DCE or DTE
02		AT Commands and Result Codes	AT Dial Command Only
01		DIU Connected	No DIU Connected

LED	X	LED ON	LED OFF
20		Data Security Group 4	Not Included
19		Data Security Group 2	Not Included
18		Data Security Group 3	Not Included
17		Data Security Group 1	Not Included
16			
15			
14			
13			
12			
11			
10			
09			
08			
07			
06		DTR Pulse With <sup>5</sup> Data Release	No DTR Pulse
05		Auto Pause <sup>3</sup> Behind PBX	No Auto Pause
04		PDIU-DS Connected	PDIU-DI(2) <sup>6</sup> Connected
03		PDIU-DS to Modem Connection	PDIU-DS to other type DCE or DTE
02		AT Commands and Result Codes	AT Dial Command Only
01		DIU Connected	No DIU Connected

NOTES:

- For more information, see the instructions preceding the record sheets. Copy this page if more than three DIUs are installed.
- Initialized data: LED 17 ON, all others OFF.
- Auto pause will be inserted after a Centrex or PBX access code is dialed by a DIU: CO line must be assigned in Program 42-0 and must have access code assigned in Program 42 (1 ~ 8). Pause time is determined by Program 12-3. A pause will also be inserted after the DK CO line access code is dialed (by the DIU) in all cases if LED 05 is turned on.
- DIUs can connect to any digital circuit in the Base Unit and on the PDKU2 and KCDU, but it can only connect to Circuits 1 ~ 7 on the PDKU1.
- If a PDIU-DS is connected to a modem, turn LED 06 ON to cause the modem to disconnect the line when the user presses the Data Release button. Modem should be sent AT Command "AT & D2" so it can recognize DTR pulse, and the PDIU-DS SW1-2 switch must be off (in the up position). This feature is for outgoing modem calls only—DTR will not pulse on incoming modem calls. Always change the modem escape sequence from "+ + +" to some other character using the "ATS2=\_\_\_\_" command; this allows AT commands to be sent to the modem or DIU independently.
- The PDIU-DI connects to 1000-series Digital Telephones, and the PDIU-DI2 connects to 2000-series Digital Telephones.

PROGRAM 21  
 MODEM POOL PORT ASSIGNMENTS



	PDIU-DS Logical Port Number		Modem Logical Port Number
Assignment 1	[ ] [ ]	—	[ ] [ ]
Assignment 2	[ ] [ ]	—	[ ] [ ]
Assignment 3	[ ] [ ]	—	[ ] [ ]
Assignment 4	[ ] [ ]	—	[ ] [ ]
Assignment 5	[ ] [ ]	—	[ ] [ ]
Assignment 6	[ ] [ ]	—	[ ] [ ]
Assignment 7	[ ] [ ]	—	[ ] [ ]
Assignment 8	[ ] [ ]	—	[ ] [ ]

NOTES:

1. For more information, see the instructions preceding the record sheets.
2. Initialized data is blank.
3. DIUs can connect to any digital circuit (port) in the DK16 Base Unit or DK8 KSU, on the PDKU2, and on the KCDU or QCDU, but can only connect to Circuits 1 ~ 7 on the PDKU1.

PROGRAM 22  
DATA INTERFACE UNIT (DIU) STATION HUNTING (DATA CALLS ONLY)



**SELECT = Logical Port Number**  
Enter the DIU port number  
of the "Hunt-From"  
station. See Note 3 for  
entering a range of ports.

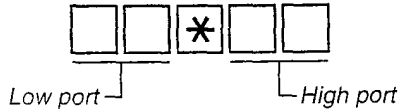
**HUNT TO =**  
Enter the Hunt To  
DIU Logical Port  
number. See Note 4.

NOTE: Shaded areas apply to DK16 only

Logical Port	00	01	02	03	04	05	06	07	08	09	10	11	12	13	14	15
Hunt To																
	16	17	18	19												

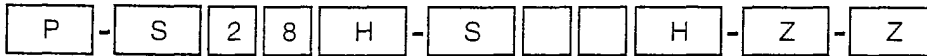
NOTES:

1. For more information, see the instructions preceding the record sheets.
2. Initialized data does not assign "Hunt-To" points to any port.
3. A range of ports may be assigned by pressing the following button sequence:



4. Press Button/LED 01 to delete a digit from "Hunt-To" port.
5. **Program 22** applies to PDIU-DI(2) and PDIU-DS data stations. If programming a PDIU-DI(2) station, use the associated digital telephone Logical Port number; the PDIU-DS is programmed using its own unique Logical Port number.

PROGRAM 28  
DK16 DSS CONSOLE/ATTENDANT TELEPHONE ASSIGNMENTS



**SELECT = (1-2)**  
Enter the DSS console number.  
See Note 4.

**DSS ATT = (1-2)**  
Enter the attendant digital or electronic telephone number. See Note 5.

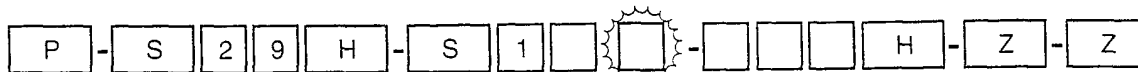
Base Unit/Expansion Unit PCB Slot (Lowest Slot to Highest)	DSS Console (DDSS/HDSS) Number	Attendant Digital / Electronic Telephone Number (1 or 2)
Base Unit (Digital Circuits):	1	
Expansion Unit PCB (PEKU or PDKU):	2	

**NOTES:**

1. For more information, see the instructions preceding the record sheets.
2. A digital DDSS console can be assigned to an electronic telephone, and an HDSS console can be assigned to a digital telephone.
3. Refer to **Program 03, Flexible PCB Slot Assignments**, for the PEKU, PDKU, Base Unit slots configured to support consoles.
4. If more than one console is associated with one attendant telephone, then specify the same number attendant telephone for both consoles associated with it.
5. Initialized data assigns console #1 to attendant telephone #1 and console #2 to attendant telephone #2.
6. DSS consoles are not available on DK8.



PROGRAM 29-1, 29-2  
DK16 DSS CONSOLE (DDSS AND HDSS) BUTTON ASSIGNMENTS  
CONSOLE



**SELECT = 1 or 2 for consoles 1 or 2, respectively  
DSS Number 1-2:**  
Each system can have up to two consoles. Enter the console to which buttons are being assigned (DSS console 1).

**DSS Button Group 1-3:**  
Each console has three groups of 20 LED buttons. Choose the group to be assigned.

**No. 01 - No. 20**  
Press the button/LED that is in the same position as the console button being assigned. The LED lights and the LCD displays the console button's number.

**Code:**  
Assign the appropriate SpeedDial, CO line access, or DSS station access code to the button chosen. See code table below for the buttons to enter. See Notes 4 and 5.

Copy this sheet as required and enter the console number and corresponding Select number.

Console Number <input type="checkbox"/>					
Group No. 1		Group No. 2		Group No. 3	
Button/Code	Button/Code	Button/Code	Button/Code	Button/Code	Button/Code
10	20	10	20	10	20
09	19	09	19	09	19
08	18	08	18	08	18
07	17	07	17	07	17
06	16	06	16	06	16
05	15	05	15	05	15
04	14	04	14	04	14
03	13	03	13	03	13
02	12	02	12	02	12
01	11	01	11	01	11

Code Table

Button Type	Code
Station Speed Dial	*10 ~ *49
System Speed Dial	*60 ~ *99
CO Line Access	01 ~ 08
DSS (Station Access)	#00 ~ #19
AC	89
NT1	91
NT2	92

NOTES:

- For more information, see the instructions preceding the record sheets.
- Initialized data assigns the Base Unit, PEKU, or PDKU console to operate with the telephone connected to the Base Unit's first digital port or the PEKU or PDKU's first port, respectively. See Program 28 to reassign a console to another telephone, if desired.
- When assigning CO line access buttons (01 ~ 08) to the DSS console, the associated telephone must be assigned access to the CO line. See Program 40.
- Initialized data assigns the **AC** (Code 89) to Group No. 3 Button 19 and the **NT** button (Code 91) to Group No. 3 Button 20 on all consoles. All other buttons are initialized as DSS and SD (for Station Speed Dial) buttons. Initialized button assignments are shown after this record sheet.
- The **NT** and **AC** buttons may be changed to **DSS**, **CO** or **SD** buttons, but they may not be reassigned to other locations.
- Important:** Only program **SD**, **CO**, **DSS**, **AC**, and **NT** buttons; programming feature buttons on a console may cause system operation problems.
- DSS consoles are not available on DK8.

PROGRAM 29

DK16 INITIALIZED DSS CONSOLE (DDSS AND HDSS) BUTTON ASSIGNMENTS

#09	#19	*19	*29	*39	NT1(91)
#08	#18	*18	*28	*38	AC(89)
#07	#17	*17	*27	*37	*47
#06	#16	*16	*26	*36	*46
#05	#15	*15	*25	*35	*45
#04	#14	*14	*24	*34	*44
#03	#13	*13	*23	*33	*43
#02	#12	*12	*22	*32	*42
#01	#11	*11	*21	*31	*41
#00	#10	*10	*20	*30	*40

← DSS Keys →      ← Speed Dial Keys →

PROGRAM 30  
STATION CLASS OF SERVICE



**SELECT = Logical Port Number(s)** —————  
Enter the logical port number(s) to which class of service must be assigned. See Note 3 for entering a range of ports.

**Button/LEDs** —————  
Light LEDs for the port specified in the last step. All Button/LEDs marked with an "X" in the table below should be lit.

NOTE: Shaded areas apply to DK16 only

Feature	LED	Logical Port Numbers and DISA Port 20 <sup>14</sup>																				
		00	01	02	03	04	05	06	07	08	09	10	11	12	13	14	15	16	17	18	19	20
Priv. Override Allowed <sup>5,6</sup>	20																					
Exec. Override Allowed <sup>6</sup>	19																					
DND Override Allowed <sup>6</sup>	18																					
Change T.C.O. Code <sup>9</sup>	16																					
Change Verified A.C. <sup>10</sup>	15																					
Account Codes Verified	14																					
Digital Tele. Recv. Vol. <sup>13</sup>	13																					
Digital Tele. Recv. Vol. <sup>13</sup>	12																					
Dial Pulse/(DTMF Off) <sup>8</sup>	11																					
Change DISA Security Code <sup>7</sup>	10																					
Change TR Override Code <sup>11</sup>	09																					
Forced Acc't Code	08																					
OCA/Busy Override Automatic <sup>4</sup>	07																					
ABR Access Enabled <sup>15</sup>	06																					
Speed Dial Allowed	05																					
	04																					
Mic on at Start of Call <sup>12</sup>	03																					
Mic Button Lock Enabled <sup>12</sup>	02																					
Speakerphone Enabled	01																					

NOTES:

- For more information, see the instructions preceding the record sheets.
- Initialized data reads LEDs 01, 05, 07, and 12 ON for all ports.
- A range of ports may be specified by entering:   \*    

Low port
High port
- If this LED is turned OFF, OCA and Busy Override must be accessed manually by dialing 2. If kept ON, ACB and Executive Override cannot be accessed.
- If all stations are allowed Privacy Override, (the system will be non-private), allowing up to three telephones to talk on the same CO line.
- See **Program 10-2** to enable/disable Priv./Exec./DND override warning tones.
- To change DISA code from selected stations: Dial Intercom 6 5 8 + code + Redial.
- DP or DTMF is specified for standard telephones only, KSTU, PSTU, or PESU (Circuits 1 and 2) in DK16, QSTU in DK8.
- To change a four-digit Traveling Class Override (T.C.O.) code: Dial Intercom + \*\*\* + code + Redial.  
 \*\*\* = 6 2 2 - Class 1, 6 2 3 - Class 2, 6 2 4 - Class 3, 6 2 5 - Class 4.
- To change Verified Account Codes from selected stations: Dial Intercom + 6 5 9 + Code Number (000 ~ 299) for DK16; (000 ~ 099) for DK8 + code (1 ~ 15 digits) + Redial. Note that the total Account Code digit length is set in **Program 60-4**; all digits do not have to be verified.
- To change the four-digit T. R. override codes (1 or 2) from selected stations: Dial Intercom + 6 5 4 + code + Redial; or Intercom + 6 5 5 + code + Redial.
- Mic ON/OFF at start of call (LED 03 ON = Mic ON, LED 03 OFF = Mic OFF) is only in effect if Mic button lock is enabled (LED 02 = ON).
- There are nine handset receiver volume levels, 1 ~ 9 (9 being the highest). The initial off-hook level can be set anywhere from level 2 to 5. Set the initial level with one of the following combinations: Level 2 = 12 OFF/13 OFF; Level 3 = 12 ON/13 OFF (default level); Level 4 = 12 OFF/13 ON; Level 5 = 12 ON/13 ON.
- To require DISA callers to dial Verified Forced Account Codes before accessing outside CO lines, light LEDs 08 and 14 on DK16 (Port 20) or DK8, (Port 10).
- For ABR to function, QRCU (DK8) or K4RCU (DK16) must be installed to detect busy tone.

PROGRAM 31  
STATION CLASS OF SERVICE



**SELECT = Logical Port Number(s)**  
Enter the Logical Port number(s) to which class of service must be assigned.  
See Note 3 for entering a range of ports.

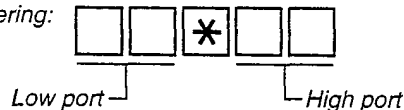
**Button/LEDs**  
Light LEDs for the port specified in the last step. All buttons/LEDs marked with an "X" in the table below should be lit.

NOTE: Shaded areas apply to DK16 only

Feature	LED	Logical Port Numbers																			
		00	01	02	03	04	05	06	07	08	09	10	11	12	13	14	15	16	17	18	19
VP (B + Station No.)	20																				
VP (B + No Station)	19																				
Block Exec./Priv. Ovr. <sup>6</sup>	18																				
End/End Signal Rcv (VM)	17																				
Receive VM ID Code	16																				
VP Integration (A/D)	15																				
Group Page 4 - EKTs/DKTs	14																				
Group Page 3 - EKTs/DKTs	13																				
Group Page 2 - EKTs/DKTs	12																				
Group Page 1 - EKTs/DKTs	11																				
AC Page - EKTs/DKTs <sup>7</sup>	10																				
VM (No Conference)	09																				
VM Group 4	08																				
VM Group 3	07																				
VM Group 2	06																				
VM Group 1	05																				
VM to VM Call Blocking <sup>5</sup>	04																				
OCA Enabled (Receive)	03																				
Handsfree No Warning	02																				
Handsfree Disabled	01																				

NOTES:

- For more information, see the instructions preceding the record sheets.
- Initialized data reads LED 10 ON for all ports.
- A range of ports may be specified by entering:



- If Button/LED 15 is lit, Button/LED 17 must be lit.  
If Button/LED 19 is lit, Button/LED 17 must be lit.  
If Button/LED 20 is lit, Button/LEDs 17 and 19 must both be lit.
- Voice Mail (VM) to VM call block should be ON for all VM (QSTU, KSTU/PSTU/PESU) ports if the VM/Auto Attendant machine does supervised and/or screened transfer.
- Block Exec./Priv. override (LED 18 ON) prevents Privacy Override to the selected station unless the **Privacy Release** button is ON at that station; this option (LED 18 ON) prevents Executive Override to the station under all conditions.
- Button/LED 10 enables (disables) a telephone to receive an All Call page. All telephones can initiate an All Call page.

PROGRAM 32  
 AUTOMATIC PREFERENCE



**SELECT = Logical Port Number**  
 Enter the Logical Port number of the station having preference defined. See Note 3 below for entering a range of ports.

**DATA = Ringing Code**  
 Enter 0 to disable Ringing Line Preference.  
 Enter 1 to enable Ringing Line Preference.

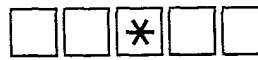
**Automatic Preference Code:**  
 Enter 00 for no selection.  
 Enter 01 for intercom.  
 Enter 02 for lowest CO line.  
 Enter 11 ~ 18 for Line Groups 1 - 8.

NOTE: Shaded areas apply to DK16 only

Logical Port Number	Ringing Code (0 or 1)	Automatic Preference Code
00		
01		
02		
03		
04		
05		
06		
07		
08		
09		
10		
11		
12		
13		
14		
15		
16		
17		
18		
19		

NOTES:

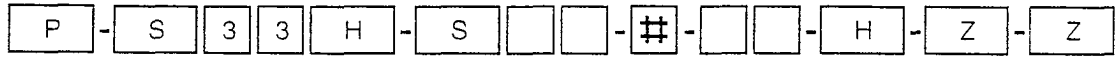
- For more information, see the instructions preceding the record sheets.
- Initialized data assigns Ringing Code 1 and Automatic Off-hook Code 00 for all ports.
- To enter a range of ports dial the following button sequence:



Low port — High port

- Automatic Preference applies to going off-hook (lifting the handset) and pressing the **Spkr** button.
- This program applies to digital and electronic telephones only; standard telephones always select the system intercom path when going off-hook (lifting the handset).

PROGRAM 33  
STATION HUNTING (VOICE CALLS ONLY)



**SELECT = Logical Port Number (00-19)**  
Enter the Logical Port number of the "Hunt-From" station. See Note 3 for entering a range of ports.

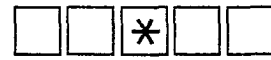
**HUNT TO = Logical Port Number (00-19)**  
Enter the "Hunt-To" Logical Port number. See Note 4.

NOTE: Shaded areas apply to DK16 only

Logical Port	00	01	02	03	04	05	06	07	08	09	10	11	12	13	14	15
Hunt To																
	16	17	18	19												

NOTES:

- For more information, see the instructions preceding the record sheets.
- Initialized data does not assign "Hunt-To" points to any port.
- A range of ports may be assigned by pressing the following button sequence:



- Press Button/LED 01 to delete a digit from a "Hunt-To" port.
- If a hunt station is in the Call Forward mode, calls will be directed to the forwarded destination.
- CO lines will hunt if they are programmed to ring at the Hunt station only: CO lines that ring at more than one station in any given ring program (81 - 89).

PROGRAMMING PROCEDURES-INSTRUCTIONS/SYSTEM RECORDS  
 SECTION 100-816-302  
 MARCH 1993

PROGRAM 34  
 HOLD/PARK RECALL TIMING

A - S 3 4 H - S   #    H - Z - Z

**SELECT = Logical Port Number (00~19)**  
 Enter the port number having  
 its Hold/Park Recall Time defined.  
 See Note 4 for entering a  
 range of ports.

**HOLD TIME = Seconds**  
 Enter the number of seconds the  
 system will wait. Use three digits.  
 Acceptable range is 000 or  
 011~160. See Note 3.

NOTE: Shaded areas apply to DK16 only

Logical Port	00	01	02	03	04	05	06	07	08	09	10	11	12	13	14	15
Seconds																
	16	17	18	19												

NOTES:

1. For more information, see the instructions preceding the record sheets.
2. Initialized data assigns a Hold /Park recall time of 032 seconds to all ports.
3. Enter 000 for no Hold/Park recall. Enter 011 ~ 160 for 11 to 160 seconds.
4. Enter a range of ports by keying in the following sequence:

\*    
 Low port High port

PROGRAM 35  
STATION CLASS OF SERVICE



**SELECT = Logical Port Number (00-19)**

Enter the port number(s) being defined. See Note 3 for entering a range of ports.

**Button/LEDs**

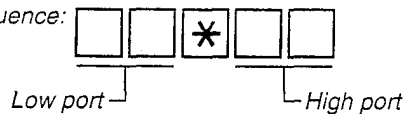
Select LEDs to light for the port specified in the last step. All LEDs marked with an "X" in the table below should be lit.

NOTE: Shaded areas apply to DK16 only

Feature	LED	Logical Port Numbers																			
		00	01	02	03	04	05	06	07	08	09	10	11	12	13	14	15	16	17	18	19
Busy Station Transfer <sup>5</sup>	20																				
Busy Station Ring <sup>6</sup>	19																				
Automatic Hold	18																				
Disable continuous DTMF tones on DKT 2000 <sup>8</sup>	17																				
No CF/NA on Handsfree <sup>7</sup>	16																				
	15																				
	14																				
	13																				
	12																				
	11																				
	10																				
	09																				
	08																				
	07																				
	06																				
LCD Indiv. Message	05																				
Message Waiting (RCV)	04																				
	03																				
LCD Type/32-ON/12-OFF <sup>4</sup>	02																				
LCD Display <sup>4</sup>	01																				

NOTES:

- For more information, see the instructions preceding the record sheets.
- Initialized data reads Buttons/LEDs 01, 02, 04, and 05 lit for ports.
- Enter a range of ports by keying in the following sequence:



- Button/LEDs 01, 02, and 04 should be lit for all stations connected to voice mail (VM) ports to allow proper VM integration. Button/LEDs 01 and 02 should be lit for all stations (even non-LCD), unless it is desired to disable the LCD and message waiting indication.
- This feature applies to calling ports (typically VM/auto attendant ports) that transfer CO line calls (can be telephone stations, too).
- This feature applies to called ports (stations) that must receive calls from VM/auto attendant ports (can be telephone stations, too) when busy.
- Does not apply to Off-hook Call Announce calls; OCA calls will forward after 12 seconds (CFNA time out) if not answered.
- May be required for dialing with Personal Computers connected to 2000-series digital telephone (PDIU-DI2) data interface units.



PROGRAM 36  
FIXED CALL FORWARD

P	-	S	3	6	H	-	S			#			H	-	Z	-	Z
---	---	---	---	---	---	---	---	--	--	---	--	--	---	---	---	---	---

**SELECT = Logical Port Number (00-19)**

Enter the port number of the station that needs a Fixed Call Forward location assigned. See Note 3 for a range of ports.

**FORWARD TEL = Port Number (00-19)**

Enter the port number of the station or VM port that will be call forwarded to when the Fixed Call Forward button is pressed.

NOTE: Shaded areas apply to DK16 only

Logical Port	00	01	02	03	04	05	06	07	08	09	10	11	12	13	14	15
Forward Tel																
	16	17	18	19												

**NOTES:**

1. For more information, see the instructions preceding the record sheets.
2. Initialized data does not assign a Fixed Call Forward location to any port.
3. To enter a range of ports, key in the following sequence:

		*		
--	--	---	--	--

Low port

High port

4. Press Button/LED 01 to enter blanks.
5. See **Program 39**, Code 86, to assign Fixed Call Forward buttons on DKTs/EKTs.
6. Fixed Call Forward will forward all calls to the designated port.
7. Stations that have Fixed Call Forward set will not ring.
8. **Program 92-9** does not clear Fixed Call Forward memory.

**PROGRAM 37  
RING TRANSFER (CAMP-ON) RECALL TIME**

P	-	S	3	7	H	-	S			#				H	-	Z	-	Z
---	---	---	---	---	---	---	---	--	--	---	--	--	--	---	---	---	---	---

**SELECT = Logical Port Number (00-19)**

Enter the number of the port that needs a Ring Transfer Recall time assigned. See Note 3 for entering a range of ports.

**HOLD TIME = Ring Transfer Recall Time**

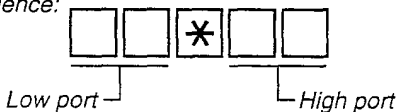
Enter the Ring Transfer Recall Time (in seconds). The acceptable range is 011 ~ 999 seconds. Use three digits.

NOTE: Shaded areas apply to DK16 only

<b>Logical Port</b>	00	01	02	03	04	05	06	07	08	09	10	11	12	13	14	15
<b>Hold Time</b>																
	16	17	18	19												

**NOTES:**

1. For more information, see the instructions preceding the record sheets.
2. Initialized data assigns a Ring Transfer Recall Time of 032 seconds to all ports.
3. To enter a range of ports, key in the sequence:



4. Ring Transfer Recall Time is the time it takes to recall a station **that originates an unanswered or busy (camped-on) transferred call**.
5. Ring Transfer must be allowed (**Program 10-1, LED 07 ON**) for transfer recall to function; otherwise Recall will be immediate.
6. Ring Transfer to stations in the Do Not Disturb Mode is not allowed; recall will be immediate if it is attempted—no matter what the **Program 37** recall time is.

PROGRAM 38  
DIGITAL AND ELECTRONIC TELEPHONE BUTTONSTRIP TYPE



**SELECT = Logical Port Number (00-19)**  
Enter the port number of the station that needs a keystrip defined.  
See Note 4 for entering a range of ports.

**KEY MENU = Code**  
Enter the appropriate code as follows:

Telephone Type	Code
10-key (DK8/16)	21
20-key (DK8/16)	31
20-key (DK8)	32
20-key (DK16)	33

NOTE: Shaded areas apply to DK16 only

See Note 5 - 10Speed Dial

Logical Port	00	01	02	03	04	05	06	07	08	09	10	11	12	13	14	15
Key Menu																
	16	17	18	19												

NOTES:

- For more information, see the instructions preceding the record sheets.
- Initialized data assigns Code 31 to all ports.
- Always complete **Program 38** before proceeding to **Program 39**.
- To enter a range of ports, key in the sequence:   \*

Low port  High port

- The DK8 default for 2000-series digital telephone keystrips assigned by codes are as follows:

Speed Dial
Do Not Disturb
SD12
SD11
SD10
Line4
Line 3
Line 2
Line 1
Intercom

Code 21  
10-button

All Call Voice Page	Speed Dial
SD13	Do Not Disturb
SD12	DSS17
SD11	DSS16
SD10	DSS15
Line 4	DSS14
Line 3	DSS13
Line 2	DSS12
Line1	DSS11
Intercom	DSS10

Code 31 (Initialized)  
20-button

SD14	Speed Dial
SD13	Do Not Disturb
SD12	SD22
SD11	SD21
SD10	SD20
Line 4	SD19
Line 3	SD18
Line 2	SD17
Line1	SD16
Intercom	SD15

Code 32  
20-button

- The DK8 default 1000-series digital telephone keystrip assigned by codes are as follows:

DSS15	DSS16	DSS17	Do Not Disturb	Speed Dial
DSS10	DSS11	DSS12	DSS13	DSS14
SD105	SD11	SD127	SD13	All Call Voice Page
Intercom	Line 1	Line 2	Line 3	Line 4

Code 31 (Initialized)  
20-button

SD20	SD21	SD22	Do Not Disturb	Speed Dial
SD15	SD16	SD13	SD18	SD19
SD10	SD11	SD12	SD13	SD14
Intercom	Line 1	Line 2	Line 3	Line 4

Code 32  
20-button

### PROGRAM 38 (continued) ELECTRONIC AND DIGITAL TELEPHONE KEYSRIP TYPE

7. The DK16 default for 2000-series digital telephone keystrips assigned by codes are as follows:

Speed Dial
Do Not Disturb
Line 7
Line 6
Line 5
Line 4
Line 3
Line 2
Line 1
Intercom

Code 21

SD10	Speed Dial
Line 8	Do Not Disturb
Line 7	SD18
Line 6	SD17
Line 5	SD16
Line 4	SD15
Line 3	SD14
Line 2	SD13
Line 1	SD12
Intercom	SD11

Code 31 (Initialized)

SD 10	Flash
Line 8	Do Not Disturb
Line 7	Speed Dial
Line 6	Redial
Line 5	Spd Dial Pause
Line 4	SD 15
Line 3	SD 14
Line 2	SD 13
Line 1	SD 12
Intercom	SD 11

Code 33

8. The DK16 default 1000-series digital telephone keystrips assigned by the codes are as follows:

SD16	SD17	SD18	Do Not Disturb	Speed Dial
SD11	SD12	SD13	SD14	SD15
Line 5	Line 6	Line 7	Line 8	SD10
Intercom	Line 1	Line 2	Line 3	Line 4

Code 31 (Initialized)  
20-button

Spd Dial Pause	Redial	Speed Dial	Do Not Disturb	Flash
SD11	SD12	SD13	SD14	SD15
Line 5	Line 6	Line 7	Line 8	SD10
Intercom	Line 1	Line 2	Line 3	Line 4

Code 33  
20-button

9. The DK16 electronic telephone keystrip code assignments are as follows:

MW/FL
DND
CO7
CO6
CO5
CO4
CO3
CO2
CO1
INT

Code 21  
10-button

SD10	MW/FL
C08	DND
C07	SD18
C06	SD17
C05	SD16
C04	SD15
C03	SD14
C02	SD13
C01	SD12
INT	SD11

Code 31 (Initialized)  
20-button

SD10	MW/FL
C08	DND
C07	SDS
C06	RDL
C05	PAU
C04	SD15
C03	SD14
C02	SD13
C01	SD12
INT	SD11

Code 33  
20-button

10. DK8 and KD16 Programming templates for the digital and electronic telephones are shown below.

10	20
09	19
08	18
07	17
06	16
05	15
04	14
03	13
02	12
01	11

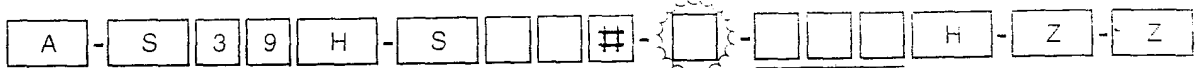
2000-Series Digital Telephone  
6500-Series Electronic Telephone

16	17	18	19	20
11	12	13	14	15
06	07	08	09	10
01	02	03	04	05

1000-Series Digital Telephone

PROGRAMMING PROCEDURES-INSTRUCTIONS/SYSTEM RECORDS  
SECTION 100-816-302  
MARCH 1993

PROGRAM 39  
FLEXIBLE BUTTON ASSIGNMENT REFERENCE GUIDE



SELECT = Port Number or range. See Note 4.

Press LED/button to be defined. See tables on the following pages.

Code:

Enter the appropriate code that corresponds to the feature to be assigned. See the feature code reference table below.

Button Function	Button Labels	Code	Notes
Account Code	Account Code or ACCOUNT	50	Allows a Voluntary Account Code to be entered
Alarm	Alarm Reset or ALRM	77	Resets alarm condition system wide
All Call Voice Page	All Call Page or AC	89	Pages all idle electronic/digital telephones over speaker
Automatic Busy Redial	Auto Busy Redial or ABR	70	Sets ABR of busy outgoing number
Automatic Callback Busy	Auto Callback or ACB	94	Sets ACB for station recalled by busy line
Background Music	Tel Set Music or BGM	78	Turns BGM ON or OFF through station speaker
Call Forward All Calls	Call Frwd All Calls or CFAC	87	All calls forward to selected station
Call Forward A.C. Fixed	Call Frwd to: or CFF	86	Forwards all calls to pre-defined destination. See Prog. 36
Call Forward Busy	Call Frwd Busy or CFB	59	Forwards calls to selected station if station is busy
Call Forward Busy/No Answer	Call Frwd Busy/ NAns or CFB/NA	57	Forwards calls to selected station if station is busy or does not answer
Call Forward No Answer	Call Frwd No Answer or CFNA	58	Forwards calls to selected station if station does not answer
Call Pickup	Directed Pickup or PKUP	84	Picks up ringing or held intercom, CO calls, and page
Call Pickup Tenant 1	PKUP1	83	Picks up tenant 1 ringing CO calls
Call Pickup Tenant 2	PKUP2	82	Picks up tenant 2 ringing CO calls
CO Line Appearance	Line 01 - 08 or CO 01 - CO 08	01 - 08	CO line access of appearing calls
Data	Data Call or DATA	56	Used to place data call
Data Release	Data Release or DRLS	54	Releases data call
Direct Station Selection	DSS	#00 - #95	Assigns DSS hotline keys to port number
Do Not Disturb	Do Not Disturb or DND	98	Prevents calls to station
Door Lock 0	Unlock Door 0 or DRLK 0	71	Momentarily unlocks door (3 or 6 sec.) PIOUS/PIOU

Button Function	Button Labels	Code	Notes
Door Lock 1 and Door Lock 2	Unlock Door 1 or DRLK 1	72	Momentarily unlocks door (3 or 6 sec.). See Prog. 77-1 and 77-2.
	Unlock Door 2 or DRLK 2	73	
Intercom	Intercom or INT	00	Intercom line access key
LCD Message	MSG	81	Begins LCD message selection
Message Waiting and Flash	Flash or MW/FL	99	Provides message waiting LED for EKT and Flash key
Microphone Cut-off	Microphn Cut-off or MCO	88	Sets microphone on/off for incoming handsfree intercom calls
Modem	Modem or MODEM	55	Used to reserve modem in modem pool
Night Transfer Tenant 1	Night Transfer 1 or NT1	91	Sets Tenant 1 CO DAY/NIGHT ringing mode
Night Transfer Tenant 2	Night Transfer 2 or NT2	92	Sets Tenant 2 CO DAY/NIGHT ringing mode
Pause	Spd Dial Pause or PAU	95	Sets a pause in Speed Dial. See Program 12-3
Pause (Long)	Spd Dial Lng Pause or PAU/L	93	Sets a 10-second pause in Speed Dial
Pooled Line	Pooled Line Grp or PL	61 - 68	Multiple CO lines may appear under one key
Privacy	Privacy On Line or PRIVACY	53	Prevents Privacy Override (not Exc. Over.)
Privacy Release	Privacy Release or PRV RLS	79	Changes station Privacy mode to Non-private for COs
Redial Last Number (# key)	RDL (EKT only)	96	Redials the last number
Release	Release Call or RLS	76	Releases current call and makes station idle
Save Last Number	Save Last Number or SAVE	85	Saves last number dialed for future speed dial
Speed Dial Select (* key)	Speed Dial or SDS	97	Begins speed dial selection
Station Speed Dial Codes	SD	*10 - *49	Reserves key for station speed dial
System Speed Dial Codes	SD	*60 - *99	Speed dial number set by station port #00
Tone	Tone Dial Select or TONE	90	CO dial signals set to tone or pulse

NOTES:

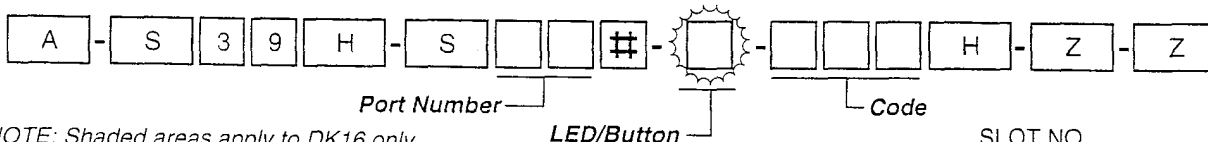
- For more information, see instructions preceding record sheets.
- Complete Program 38 before Program 39.
- Initialized data assigns the keypad pattern associated with Code 31 from Program 38.
- Specify a range of ports by keying in:



Low port — High port

- Flash (FLASH) (MW/FL):** Sets pauses in Speed Dial if telephone does not have a pause button. Sets flashes in Speed Dial numbers if telephone has a pause button.
- Redial (REDIAL or RDL) and Speed Dial (SDS):** Both buttons must be programmed on Electronic telephones; not allowed separately. Recommended on all stations using voice mail, since they allow easy access of \* and # DTMF buttons (see note 3 below).
- Pooled Line Grp (PL):** Codes 61 - 68 represent CO line groups 81 - 88. Maximum four Pooled Line Grp (PL) buttons per pooled line group on each station.
- Redial** is a fixed button on 2000-series Digital Telephones and **REDIAL** is a fixed button on 1000-series Digital telephones. Do not assign button as flexible button on digital telephones; also, **Speed Dial (SDS)** is initialized on flexible button 20 on Digital telephones.

PROGRAM 39  
FLEXIBLE BUTTON ASSIGNMENT FOR PORTS \_\_\_ TO \_\_\_



NOTE: Shaded areas apply to DK16 only

SLOT NO. \_\_\_\_\_

BUTTON	CODE
Account Code (ACCOUNT)	50
Alarm Reset (ALRM)	77
All Call Page (AC)	89
Auto Busy Redial (ABR)	70
Auto Callback (ACB)	94
Tel Sct Music (BGM)	78
Call Frwd All Calls (CFAC)	87
Call Frwd to _ (CFF)	86
Call Frwd Busy (CFB)	59
Call Frwd Busy/NAns (CFB/NA)	57
Call Frwd No Answer (CFNA)	58
Directed Pickup (PKUP)	84

BUTTON	CODE
Directed Pickup 1 (PKUP1)	83
Directed Pickup (PKUP2)	82
Line 1 - 08 CO 01 - CO 08	01 - 08
Data Call (DATA)	56
Data Release (DRLS)	54
DSS	#00 - #95
Do Not Disturb (DND)	98
Unlock Door 0 (DRLK 0)	71
Unlock Door 1 (DRLK 1)	72
Unlock Door 2 (DRLK 2)	73

BUTTON	CODE
Intercom (INT)	00
LCD MSG Select (MSG)	81
Flash (MW/FL)	99
Microphn Cut-off (MCO)	88
Modem (MODEM)	55
Night Transfer 1 (NT1)	91
Night Transfer 2 (NT2)	92
Spd Dial Pause (PAU)	95
Spd Dial Lng Pause (PAU/L)	93
Pooled Line Grp (PL)	61 - 68
Privacy On Line (PRIVACY)	53

BUTTON	CODE
Privacy Release (PRV. RLS)	79
Redial (RDL) <sup>3</sup>	96
Release Call (RLS)	76
Save Last Number (SAVE)	85
Speed Dial (SDS)	97
SD Stations	* 10 - *49
SD System	* 60 - *99
Tone Dial Select (TCNE)	90

PORT NO. \_\_\_\_ 10  LCD   
20  DIU

LOCATION:

Button	Code	Button	Code
10		20	
09		19	
08		18	
07		17	
06		16	
05		15	
04		14	
03		13	
02		12	
01		11	

PORT NO. \_\_\_\_ 10  LCD   
20  DIU

LOCATION:

Button	Code	Button	Code
10		20	
09		19	
08		18	
07		17	
06		16	
05		15	
04		14	
03		13	
02		12	
01		11	

PORT NO. \_\_\_\_ 10  LCD   
20  DIU

LOCATION:

Button	Code	Button	Code
10		20	
09		19	
08		18	
07		17	
06		16	
05		15	
04		14	
03		13	
02		12	
01		11	

PORT NO. \_\_\_\_ 10  LCD   
20  DIU

LOCATION:

Button	Code	Button	Code
10		20	
09		19	
08		18	
07		17	
06		16	
05		15	
04		14	
03		13	
02		12	
01		11	

PORT NO. \_\_\_\_ 10  LCD   
20  DIU

LOCATION:

Button	Code	Button	Code
10		20	
09		19	
08		18	
07		17	
06		16	
05		15	
04		14	
03		13	
02		12	
01		11	

PORT NO. \_\_\_\_ 10  LCD   
20  DIU

LOCATION:

Button	Code	Button	Code
10		20	
09		19	
08		18	
07		17	
06		16	
05		15	
04		14	
03		13	
02		12	
01		11	

PORT NO. \_\_\_\_ 10  LCD   
20  DIU

LOCATION:

Button	Code	Button	Code
10		20	
09		19	
08		18	
07		17	
06		16	
05		15	
04		14	
03		13	
02		12	
01		11	

PORT NO. \_\_\_\_ 10  LCD   
20  DIU

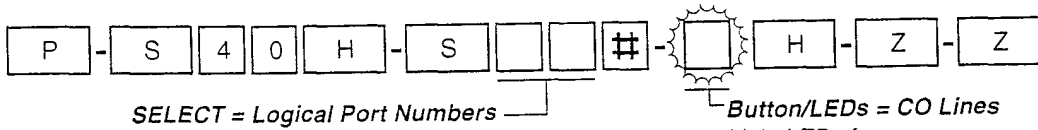
LOCATION:

Button	Code	Button	Code
10		20	
09		19	
08		18	
07		17	
06		16	
05		15	
04		14	
03		13	
02		12	
01		11	

NOTES:

1. **DSS** buttons are used for voice calls only; **SD** buttons are used for voice and/or data calls.
2. To allow a station to set \* and # DTMF tones in speed dial numbers, the station must have the **Speed Dial (SDS)** and **Redial (REDIAL) (RDL)** buttons. Digital telephones only require the **Speed Dial (SDS)** button, because the **Redial (REDIAL)** button is fixed on them. Digital telephones initialize with the **Speed Dial (SDS)** button (see Program 38).
3. The **Redial (REDIAL)** button is fixed on digital telephones; do not assign this button as a flexible button on digital telephones; also, **Speed Dial (SDS)** is initialized on flexible button 20 on Digital telephones.

PROGRAM 40  
 STATION CO LINE ACCESS

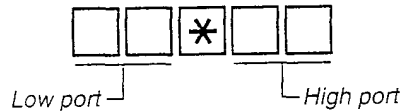


NOTE: Shaded areas apply to DK16 only

CO	LED	Port Numbers																				
		00	01	02	03	04	05	06	07	08	09	10	11	12	13	14	15	16	17	18	19	20
08	08																					
07	07																					
06	06																					
05	05																					
04	04																					
03	03																					
02	02																					
01	01																					

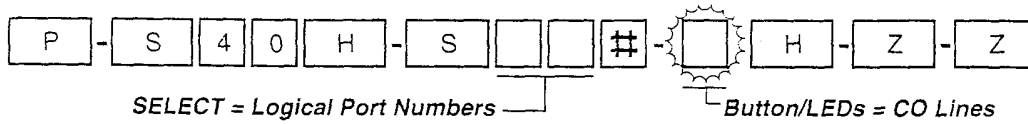
NOTES:

1. For more information, see the instructions preceding the record sheets.
2. Initialized data reads all LEDs ON for all CO lines. Complete CO line access is allowed on all ports.
3. Denying access in this program applies to **all** access options, including LCR.
4. This program also denies Pickup CO line access.
5. A range of ports may be entered by keying in:



6. **DK16**, Port 20 and **DK8**, Port 10 are used to allow or to deny Direct Inward System (DISA) access.

PROGRAM 41  
STATION OUTGOING CALL RESTRICTION

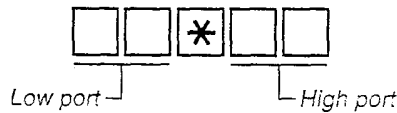


NOTE: Shaded areas apply to DK16 only

CO	LED	Port Numbers																				
		00	01	02	03	04	05	06	07	08	09	10	11	12	13	14	15	16	17	18	19	20
08	08																					
07	07																					
06	06																					
05	05																					
04	04																					
03	03																					
02	02																					
01	01																					

NOTES:

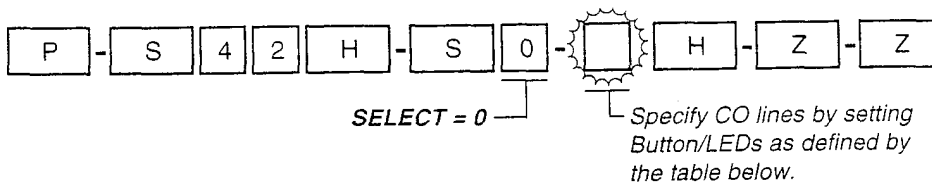
1. For more information, see the instructions preceding the record sheets.
2. Initialized data reads all LEDs OFF for all CO lines (all stations allowed outgoing access to all CO lines).
3. This program denies all outgoing calls except when using Least Cost Routing.
4. A range of ports may be entered by keying in:



5. Restricted CO lines may be accessed for ABR calls.
6. DK16, Port 20 and DK8, Port 10 are used to allow or to deny Direct Inward System (DISA) access.



PROGRAM 42-0  
 CO LINE TO PBX/CENTREX CONNECTION



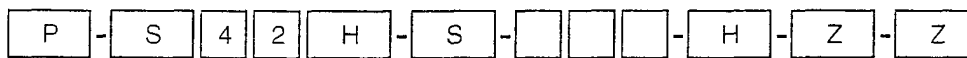
NOTE: Shaded areas apply to DK16 only

LED	(CO Line)	Set Button/LEDs	
		CENTREX/PBX Connection (LED on)	Normal (LED off)
08	(08)		
07	(07)		
06	(06)		
05	(05)		
04	(04)		
03	(03)		
02	(02)		
01	(01)		

NOTES:

1. For more information, see the instructions preceding the record sheets.
2. Initialized data reads all LEDs OFF for all CO lines.
3. This program must be utilized to allow CENTREX/PBX (after flash) features to operate.
4. If CO line is programmed for behind CENTREX/PBX (LED ON), re-seize guard time is 1.5 seconds. If CO line is programmed for normal operation guard time is 0.45 seconds. See Program 10-1, LED 02.

PROGRAM 42-1 ~ 8  
PBX/CENTREX ACCESS CODES



**SELECT = 1-8**  
PBX Access Code Group  
Enter the PBX Group  
number 1 ~ 8 that needs  
an access code assigned.

**ACCESS CODE =**  
Enter a 2-digit access  
code for the group.  
as defined by the table  
below. See Note 3.

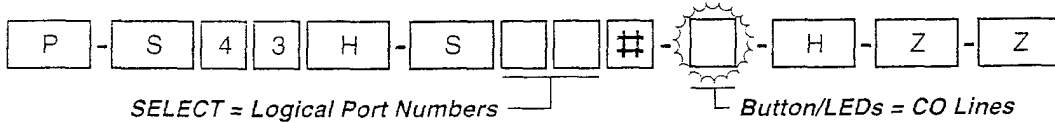
PBX/CENTREX Access Code Number	PBX/CENTREX Outgoing Trunk Access Code(s)	
	1st digit	2nd digit
1		
2		
3		
4		
5		
6		
7		
8		

**NOTES:**

1. For more information, see the instructions preceding the record sheets.
2. Initialized data assigns no access codes to PBX groups.
3.
  - If access code is single digit, enter the first digit and press Button/LED 01 as second digit.
  - Press Button/LED 01 to delete a digit.
  - Press Button/LED 02 for don't care. For example, pressing **8** + Button/LED 02 allows 80 ~ 89.
4. This program must be utilized to allow correct Toll Restriction and CENTREX/ PBX transfer operation.

PROGRAMMING PROCEDURES-INSTRUCTIONS/SYSTEM RECORDS  
 SECTION 100-816-302  
 MARCH 1993

PROGRAM 43  
 0+ CREDIT CARD DIALING OPTION



SELECT = Logical Port Numbers

Button/LEDs = CO Lines  
 Assigned to allow dial 0+ calls  
 with selected stations

NOTE: Shaded areas apply to DK16 only

CO	LED	Logical Port Numbers																			
		00	01	02	03	04	05	06	07	08	09	10	11	12	13	14	15	16	17	18	19
08	08																				
07	07																				
06	06																				
05	05																				
04	04																				
03	03																				
02	02																				
01	01																				

NOTES:

1. For more information, see the instructions preceding the record sheets.
2. For Stations and CO lines enabled in this program: 0+ calls override system Toll Restriction, and calls will disconnect automatically if the number of digits set in **Program 60-7** is not dialed when "0" is dialed as the first digit. This restricts the operator from placing calls that would be charged back to the telephone line.

PROGRAM 44A  
EMERGENCY BYPASS OF FORCED/VERIFIED ACCOUNT CODES

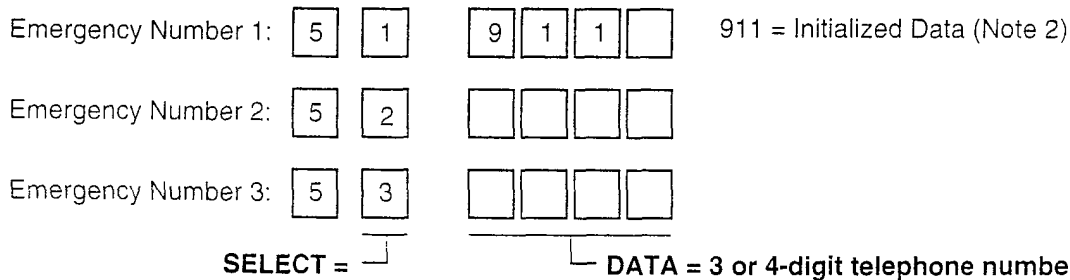


SELECT = 51, 52, or 53  
to set emergency  
number 1, 2 or 3

DATA = 3 or 4 digit emergency  
telephone number

To enter blanks.  
Press: Button/LED 01

Example



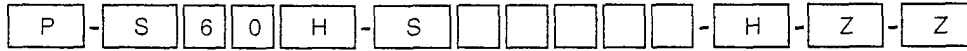
NOTES:

1. The emergency telephone numbers assigned in this program will be sent out the CO line immediately when dialed; they will bypass the Forced/Verified Account Code dialing restriction.
2. If CO lines are behind PBX or CENTREX, program the PBX/CENTREX outside trunk access code: Example: "9". A pause is automatically inserted following the first 9. See **Programs 42-0** and **42-1** to assign the CO lines and access codes for behind PBX/CENTREX operation. Also, if the system CO lines are behind CENTREX, PBX, the CENTREX/PBX trunk access codes must be programmed in front of the emergency telephone number. Example: If the CENTREX/PBX access code is "9", then enter 9911 in **Program 44-51**.
3. If Verified Account Codes assigned in **Program 69** conflict (are the same) with emergency telephone numbers assigned in **Program 44A**, **Program 44A** has priority.
4. This feature is for use with Forced (Verified or Nonverified) Account Codes, but not with ABR and DISA. It also does not override Toll Restriction; emergency numbers must be allowed using system Toll Restriction tables per normal Toll Restriction programming procedures.
5. **Program 44B** is related to Toll Restriction and is placed with the other Toll Restriction programs in this chapter.

**Programs 44B through 48** can be found in the  
Toll Restriction System Record section.

**Programs 50 through 56** can be found in the  
Least Cost Routing System Record section.

PROGRAM 60  
SMDR OUTPUT/ACCOUNT CODE DIGIT LENGTH



**SELECT = 2 - 6 (Item)**  
Make a selection to indicate which item is being assigned. Select 2 for SMDR Threshold Time. Select 3 for SMDR output, etc.

For "2" SMDR Threshold Time = 0 or 1  
For "3" SMDR COR = 0 or 1 (Data)  
For "4" ACCOUNT = 04 - 15  
For "5" TOLL DIAL, 0 - 5  
For "6" DATA = DISA security code; 1 - 15 digits  
For "7" CREDIT = Credit Card Digits; 1 - 30 digits

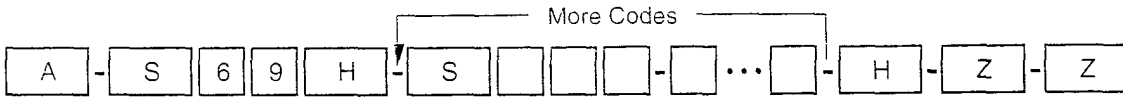
Item	Description	Data
2	SMDR Threshold Time <sup>12</sup> 0 = 1.0 seconds    1 = 10 seconds	TIME <input type="checkbox"/>
3	SMDR Output when a call is completed. 0 = Outgoing Only    1 = Incoming and Outgoing	(SMDR COR) <input type="checkbox"/>
4	<sup>10</sup> Forced/Voluntary Account Code Digit Length 04 - 15. (Digits are verified per <b>Prog. 30</b> , LED 14, and <b>Prog. 69</b> . See Note 4)	(ACCOUNT) <input type="checkbox"/> <input type="checkbox"/>
5	Printout options Toll Dial = <input type="checkbox"/> 0 All Calls <sup>7</sup> = <input type="checkbox"/> 1 Dial "0" calls only = <input type="checkbox"/> 2 Dial "1" calls only = <input type="checkbox"/> 3 Dial "00" calls only = <input type="checkbox"/> 4 Dial "1", "0", calls only = <input type="checkbox"/> 5 Dial "1" or "00" calls only	(TOLL DIAL DATA) <input type="checkbox"/>
6	DISA Security Code <sup>9</sup> (may be changed from station, per <b>Program 30</b> )	DATA <input type="checkbox"/> ~ <input type="checkbox"/>
7	Credit card call digit length, 01 - 30 digits, (see <b>Program 43</b> )	CREDIT <sup>11</sup> <input type="checkbox"/> <input type="checkbox"/>

NOTES:

- For more information, see the instructions preceding the record sheets.
- For Selection 3, initialized data assigns SMDR output to be enabled for incoming calls that are answered.
- For selection 4, initialized data assigns a 6-digit length to all Forced/Voluntary Account Codes.
- If PBX code is dialed, numbers dialed after the code will be checked.
- If A/C, O/C or SPCC code begins with "0", "1", or "00", that call will print out.
- When accessing LCR feature, all digits sent to CO will be output.
- Programming 60-3-0** (printout outgoing calls only) is still available.
- Button/LED 1 = blank, Button/LED 2 = don't care.
- If a security code is not programmed, outgoing CO line access via DISA will not require a security code when dialing.
- See **Program 69** for Verified Account Codes.
- Number of digits required when "0" is the first digit dialed; if this number of digits is not dialed, the system will disconnect the call after 20 seconds. "0" is counted as a digit. **Example:** 0 + 1 + 714 + 583 - 3700 = 12 digits; 12 should be programmed as a minimum in this case.
- Default is 10 seconds.

PROGRAMMING PROCEDURES-INSTRUCTIONS/SYSTEM RECORDS  
 SECTION 100-816-302  
 MARCH 1993

PROGRAM 69  
 VERIFIED ACCOUNT CODES (V.A.C.s)



SELECT = Verified Account Code Number (VACN) Verified Account Code (1 ~ 15 digits)

Check to Indicate VACN Range.<sup>3</sup>  
 Shaded areas apply to DK16 only.

000 ~ 024	025 ~ 049	050 ~ 074	075 ~ 099
100 ~ 124	125 ~ 149	150 ~ 174	175 ~ 199
200 ~ 224	225 ~ 249	250 ~ 274	275 ~ 299

Copy this sheet as needed. Enter the three digit verified account code number, for example: 000, 001, etc.

NAME	VACN (3-Digit)	VERIFIED ACCOUNT CODE (1 ~ 15 DIGITS)														
		1	2	3	4	5	6	7	8	9	10	11	12	13	14	15

NOTES:

1. Account Code format:
  - Account code digit length is defined in **Program 60-4** (4 ~ 15 digits).
  - To dial an Account Code, station users must always dial the quantity of digits defined in **Program 60-4**.
  - If the quantity of digits in a Verified Account Code is the same as the Account Code digit length in **Program 60-4**, the all digits will be Verified; if the quantity of digits is less, then only those digits will be Verified.
2. Account Codes may not conflict (be the same as) emergency numbers in **Program 44A**.
3. DK8 allows 100 V.A.C.s (000 ~ 099); DK16 allows 300 V.A.C.s (000 ~ 299).

PROGRAM 70  
 VERIFIED ACCOUNT CODE TOLL RESTRICTION ASSIGNMENTS

P - S 7 0 H - S - - - - - H - Z - Z

SELECT = Verified Account  
 Code Number (VACN)  
 000 ~ 299

DATA = VAC Digit  
 Restriction Code 0 or 1  
 Enter 0 for no digit restriction.  
 Enter 1 for digit restriction.

VAC Restrict Code (0 - 6)

Enter 0 for No Station Toll Restriction.  
 Enter 1 for Area Code Toll Restriction.  
 Enter 2 for Area Code Toll Restriction  
 and 0 or 1 as 1st or 2nd digit.  
 Enter 3 for Class 1 Toll Restriction.  
 Enter 4 for Class 2 Toll Restriction.  
 Enter 5 for Class 3 Toll Restriction.  
 Enter 6 for Class 4 Toll Restriction.

000 ~ 099	} <sup>6</sup> Check to Indicate VACN Range
100 ~ 199	
200 ~ 299	

NOTE: Shaded areas apply to DK16 only

VACN (3-Digit)	VAC Digit Restrict Code	VAC Restrict Code
_00		
_01		
_02		
_03		
_04		
_05		
_06		
_07		
_08		
_09		
_10		
_11		
_12		
_13		
_14		
_15		
_16		
_17		
_18		
_19		
_20		
_21		
_22		
_23		
_24		
_25		
_26		
_27		
_28		
_29		
_30		
_31		

VACN (3-Digit)	VAC Digit Restrict Code	VAC Restrict Code
_32		
_33		
_34		
_35		
_36		
_37		
_38		
_39		
_40		
_41		
_42		
_43		
_44		
_45		
_46		
_47		
_48		
_49		
_50		
_51		
_52		
_53		
_54		
_55		
_56		
_57		
_58		
_59		
_60		
_61		
_62		
_63		

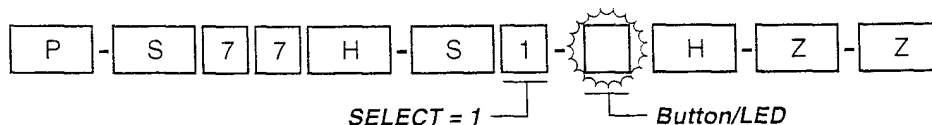
VACN (3-Digit)	VAC Digit Restrict Code	VAC Restrict Code
_64		
_65		
_66		
_67		
_68		
_69		
_70		
_71		
_72		
_73		
_74		
_75		
_76		
_77		
_78		
_79		
_80		
_81		
_82		
_83		
_84		
_85		
_86		
_87		
_88		
_89		
_90		
_91		
_92		
_93		
_94		
_95		
_99		

NOTES:

1. For more information, see the instructions preceding the record sheets.
2. Initialized data reads 00 for all VACNs.
3. This restriction overrides the normal station restriction assigned in **Program 48** when a VAC is entered at the station. The station resumes its **Program 48** restriction after the call is disconnected.
4. Range programming is not available.
5. Copy as required.
6. **DK16** allow 300 V.A.C. assignments. **DK8** allows 100 V.A.C. assignments.



PROGRAM 77-1  
PERIPHERAL OPTIONS  
(DOOR PHONES/IMDU/BASE UNIT RELAY/PIOU/PIOUS)



NOTE: Shaded areas apply to DK16 only

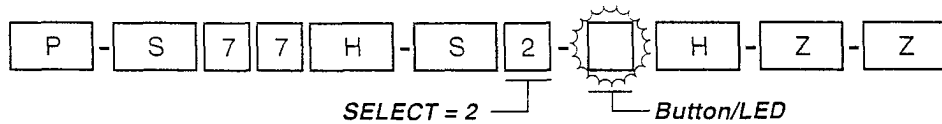
Button/LED  
Light the button/LEDs that are marked with an X in the table below.

LED	X	LED ON	LED OFF
20		Door Lock Time/6 sec.	Door Lock Time/3 sec.
17		DDCB2 on <b>DK8</b> /Port 03; <b>DK16</b> /Port 12	DKT on <b>DK8</b> /Port 03; <b>DK16</b> /Port 12
16		DDCB1 on <b>DK8</b> /Port 02; <b>DK16</b> /Port 04	DKT on <b>DK8</b> /Port 02; <b>DK16</b> /Port 04
15		—	
14		IMDU Modem (Station 619) Enabled <sup>4</sup>	IMDU Modem (Station 619)/Disabled <sup>4</sup>
13 <sup>8</sup>		Tenant 2 (NT2) CO lines – K4/Zone 4	Tenant 1 (NT1) CO lines – K4/Zone 4
12 <sup>8</sup>		Tenant 2 (NT2) CO lines – K3/Zone 3	Tenant 1 (NT1) CO lines – K3/Zone 3
11 <sup>8</sup>		Tenant 2 (NT2) CO lines – K2/Zone 2	Tenant 1 (NT1) CO lines – K2/Zone 2
10 <sup>8</sup>		Tenant 2 (NT2) CO lines – K1/Zone 1	Tenant 1 (NT1) CO lines – K1/Zone 1
09		—	
08		Door Phone Ring on Ext Page <sup>5</sup>	No Ring over Ext Page <sup>5</sup>
07		Door Lock Relay Enabled (PIOU/PIOUS) <sup>6</sup>	External Page Relay Enabled (PIOU/PIOUS) <sup>6</sup>
06		NT Relay During Night Ringing and NT1 <sup>9</sup>	NT Relay Steady With NT1 Button
05		MOH Relay Enabled (PIOU/PIOUS)	NT Relay Enabled (PIOU/PIOUS)
04		—	—
03		—	—
02		LED 01 Has Priority <sup>7</sup>	External Page on Base Unit Relay Enabled <sup>7</sup>
01		MOH on Base Unit Relay Enabled <sup>7</sup>	NT on Base Unit Relay Enabled <sup>7</sup>

NOTES:

1. For more information, see the instructions preceding the record sheets.
2. Initialized data leaves all LEDs off.
3. Port 12 is in the **DK16** Expansion Unit.
4. If a modem unit (IMDU) is installed on a **DK16** PIU or PIOUS, it can be accessed by dialing station 619.
5. If NT1 is turned on at an electronic or digital telephone, then the door phone will ring over external page.
6. This option applies to the PIU/PIOUS Door Lock Control (Unlock Door0) assigned to digital or electronic telephones using Code 71 in **Program 39**; it does not apply to DDCB door locks (Unlock Door1 ~ 2).
7. To program the **DK8** or **DK16** Key Service Unit relay for the MOH function, LEDs 02 and 01 must be ON; for the NT function, LED 02 must be ON and LED 01 OFF; for the External Page function, LED 02 must be OFF, and LED 01 can be ON or OFF.
8. Zone relays 1 ~ 4 require a PIU in the **DK16** Expansion Unit.
9. For this option, CO lines must be assigned to ring over external page in **Program 78-13**.

PROGRAM 77-2  
DOOR PHONE BUSY SIGNAL/DOOR LOCK ASIGNMENTS



Light the button LEDs marked with an X in the table below.

LED	X	LED ON	LED OFF
20		Door Phone Rings One Time	Rings Five Times
19		—	—
18		—	—
17		—	—
16		—	—
15		—	—
14		—	—
13		—	—
12		—	—
11		—	—
10		—	—
09		—	—
08		DDCB2 B-jack is Door Lock Control #2	B is connected to Door Phone 2B
07		Door phone 2C Busy Out	No Busy Signal
06		Door phone 2B Busy Out	No Busy Signal
05		Door phone 2A Busy Out	No Busy Signal
04		DDCB1 B-jack is Door Lock Control #1	B is connected to Door Phone 1B
03		Door phone 1C Busy Out	No Busy Signal
02		Door phone 1B Busy Out	No Busy Signal
01		Door phone 1A Busy Out	No Busy Signal

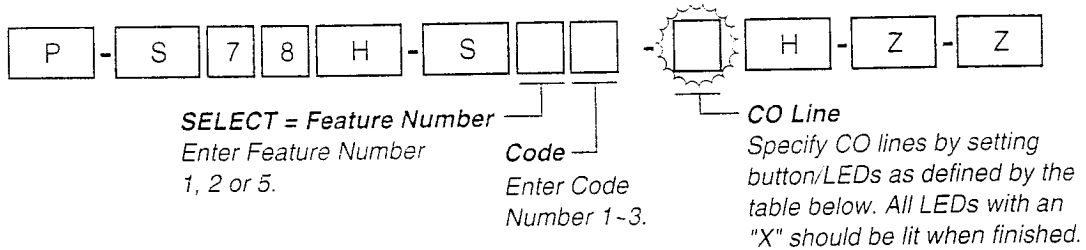
NOTES:

1. For more information, see the instructions preceding the record sheets.
2. Initialized data reads all LEDs OFF.

DDCB Port Assignments in Program 77-1

DDCB	DK16 Port No.	DK8 Port No.
1	04	02
2	12	03

PROGRAM 73  
 CO LINE SPECIAL RINGING ASSIGNMENTS  
 DISA/IMDU/NIGHT RINGING OVER EXTERNAL PAGE



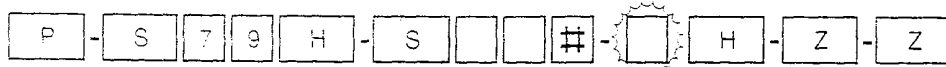
NOTE: Shaded areas apply to DK16 only

Feature Number	Code	Feature Description	CO Lines (Button/LEDs)									
			01 (01)	02 (02)	03 (03)	04 (04)	05 (05)	06 (06)	07 (07)	08 (08)		
1	3	Ring Over External Page <sup>4</sup> during NIGHT mode										
2	1	DISA CO Line during DAY Mode <sup>3</sup>										
	2	DISA CO Line during DAY2 Mode <sup>3</sup>										
	3	DISA CO Line during NIGHT Mode <sup>3</sup>										
5	1	Ring IMDU Maint. Modem during DAY Mode										
	2	Ring IMDU Maint. Modem during DAY2 Mode										
	3	Ring IMDU Maint. Modem during NIGHT Mode										

NOTES:

1. For more information, see the instructions preceding the record sheets.
2. Initialized data leaves all LEDs off.
3. See **Programs 10-1, 15, 60, 40, 41, 48, and 03** (code 92) for complete DISA programming (for DISA, the K4RCU PCB must be installed in the Base Unit).
4. See **Program 77-1** for night ringing configuration.
5. DISA lines are assigned to **DK8** Port 10 and **DK16** Port 20 in **Program 30** (Account Codes) and **Program 41** (outgoing CO line restriction) and **Program 48**.

PROGRAM 79  
 DOOR PHONE RINGING



**SELECT = Logical Port Number**  
 Enter the port number having  
 Door Phone Ringing assigned.

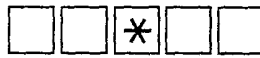
**Button/LEDs**  
 Select button/LEDs indicated  
 in the table below.

NOTE: Shaded areas apply to DK16 only

Feature	LED	Logical Port Numbers																			
		00	01	02	03	04	05	06	07	08	09	10	11	12	13	14	15	16	17	18	19
Muted ring to busy DKT/EKT <sup>5</sup>	20																				
	19																				
	18																				
	17																				
	16																				
	15																				
	14																				
	13																				
	12																				
	11																				
	10																				
	09																				
	08																				
Door phone 2C Ring	07																				
	06																				
Door phone 2B Ring	05																				
Door phone 2A Ring	04																				
Door phone 1C Ring	03																				
Door phone 1B Ring	02																				
Door phone 1A Ring	01																				

NOTES:

- For more information, see the instructions preceding the record sheets.
- Initialized data does not assign door phone ringing to any station port. All LEDs are OFF.
- A range of ports may be entered by keying in the following:



Low port in range — High port in range

- Door phones can ring any number of digital and electronic telephones, but do not ring standard telephones or other devices connected to KSTU, PESU, or PSTU station ports.
- Only the **lowest** port in a ringing group will receive muted ring tone if all EKTs DKTs in the ringing group are busy and the door phone button is pressed.

PROGRAM 80  
 DIGITAL AND ELECTRONIC TELEPHONE RINGING TONES (CO LINE CALLS)



**SELECT = Logical Port Number**  
 Enter number of port having its  
 ringing tone defined. See Note 4  
 for entering a range of ports.

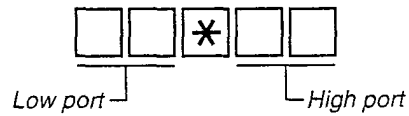
**Ringing Tone Code**  
 Enter 1 for Tone 1 (500/640 Hz).  
 Enter 2 for Tone 2 (600/800 Hz).

NOTE: Shaded areas apply to DK16 only

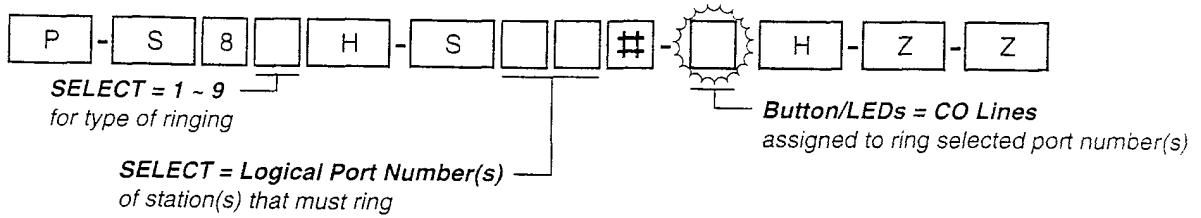
Ringing Tone (Code)	Port Numbers																			
	00	01	02	03	04	05	06	07	08	09	10	11	12	13	14	15	16	17	18	19
Tone 1 (1)																				
Tone 2 (2)																				

NOTES:

1. For more information, see the instructions preceding the record sheets.
2. Initialized data assigns Tone 1 to all station ports.
3. Tone 1 is 500 Hz modulated with 640 Hz.  
 Tone 2 is 600 Hz modulated with 800 Hz.
4. A range of ports may be specified by entering:



PROGRAM 8  (1 ~ 9)  
CO LINE/STATION RINGING ASSIGNMENTS



Selected CO lines ring selected station ports per Ringing Program options as follows:

<input type="text"/>	8 <input type="text"/>	Immediate	<input type="text"/>	8 <input type="text"/>	Immediate	<input type="text"/>	8 <input type="text"/>	Immediate
<input type="text"/>	8 <input type="text"/>	12 second delay	<input type="text"/>	8 <input type="text"/>	12 second delay	<input type="text"/>	8 <input type="text"/>	12 second delay
<input type="text"/>	8 <input type="text"/>	24 second delay	<input type="text"/>	8 <input type="text"/>	24 second delay	<input type="text"/>	8 <input type="text"/>	24 second delay

NOTE: Shaded areas apply to DK16 only

CO	LED	Logical Port Numbers																			
		00	01	02	03	04	05	06	07	08	09	10	11	12	13	14	15	16	17	18	19
08	08																				
07	07																				
06	06																				
05	05																				
04	04																				
03	03																				
02	02																				
01	01																				

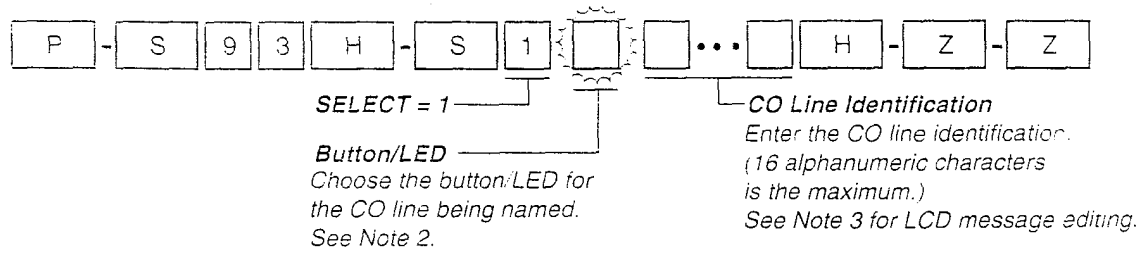
NOTES:

1. For more information, see the instructions preceding the record sheets.
2. Initialized data reads all LEDs ON for Port 00 in Program 81 and Port 01 in Program 87, all other LEDs are OFF.
3. If a CO line must Call Forward or Hunt from a station, the line must be assigned to ring at that station only.
4. A range of ports may be selected.

PROGRAMMING PROCEDURES-INSTRUCTIONS/SYSTEM RECORDS  
SECTION 100-816-302  
MARCH 1993

System Record Sheets for **Programs 90** and **92** are in the beginning of this section because they must be executed before any other programs.

PROGRAM 93  
CO LINE IDENTIFICATION



NOTE: Shaded areas apply to DK16 only

LED	CO Line	CO Line Identification (16 Characters Max. – Enter One Per Square)
08	(08)	
07	(07)	
06	(06)	
05	(05)	
04	(04)	
03	(03)	
02	(02)	
01	(01)	

NOTES:

- For more information, see the instructions preceding the record sheets.
- Initialized data assigns no identification message to CO lines.
- Special editing buttons include:
  - # to toggle between alpha and numeric modes;
  - 1** moves cursor to right;
  - \*** moves cursor to left;
  - 0** increments letters, etc.

For more detailed editing instructions, see the following page.



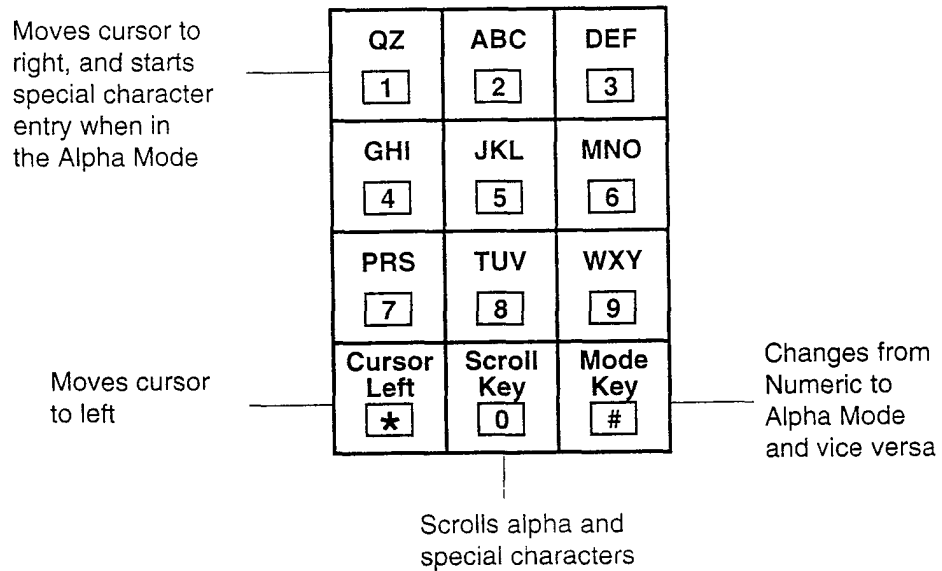
PROGRAM 93 (continued)  
 CO LINE IDENTIFICATION ALPHA/NUMERIC ENTRY

- 1) Enter **Program 93** and select the desired CO line.
- 2) Use the guide below to enter CO line identification information.

**Numeric Mode**

"0" to "9" are treated as numerals.

*NOTE: Dialpad starts out in **Numeric Mode**.  
 Use **#** button to switch to **Alpha Mode**  
 and vice versa.*



**Alpha Entry (Example):**

A → 2  
 B → 2 0  
 C → 2 0 0

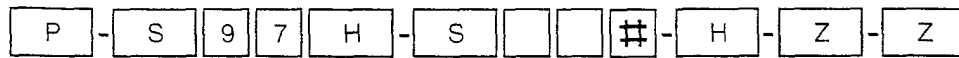
|                      |  
 Alpha                  Entry  
 Character              Sequence

**Special Character Entry:**

" Q " → 1 0  
 " Z " → 1 0 0  
 " : " → 1 0 0 0  
 " - " → 1 0 0 0 0  
 " + " → 1 0 0 0 0 0  
 " / " → 1 0 0 0 0 0 0

|                                      |  
 Special                                  Entry  
 Character                                  Sequence

PROGRAM 97  
 PRINTING PROGRAM DATA THROUGH SMDR



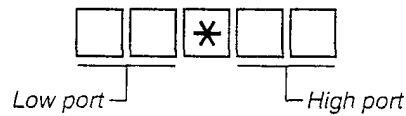
**SELECT** = Program Number  
 to be printed on SMDR.  
 See Note 2 for entering  
 a range of programs.

**DATA PRINT**  
 Printout begins.

**Spkr # # Hold**  
 Cancels printout  
 at any time.

NOTES:

1. For more information, see the instructions preceding the record sheets.
2. Enter a range of programs by keying:



## SETTING THE DATE, TIME AND DAY

### HOW TO SET THE DATE

The date can be set from an LCD electronic or digital telephone connected to a logical port 00. Press the following button sequence with the handset on-hook:

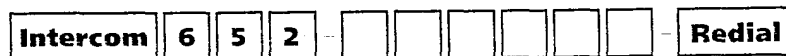


Date in year/month/day format (YYMMDD). If month or day is a single digit, precede with a zero (0).

Electronic telephones can use the # button if they do not have the **Redial (RDL)** button.

### HOW TO SET THE TIME

The time can be set from an LCD electronic or digital telephone connected to a logical port 00. Press the following button sequence with the handset on-hook:

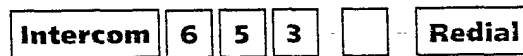


Time in hours/minutes/seconds format (HHMMSS from 000000 to 235959). If any of these values is a single digit, precede with a zero (0).

Electronic telephones can use the # button if they do not have the **Redial (RDL)** button.

### HOW TO SET THE DAY

The day can be set from an LCD electronic or digital telephone connected to a logical port 00. Press the following button sequence with the handset on-hook:



Enter the digit for today's day:

- 1 = Sunday
- 2 = Monday
- 3 = Tuesday
- 4 = Wednesday
- 5 = Thursday
- 6 = Friday
- 7 = Saturday

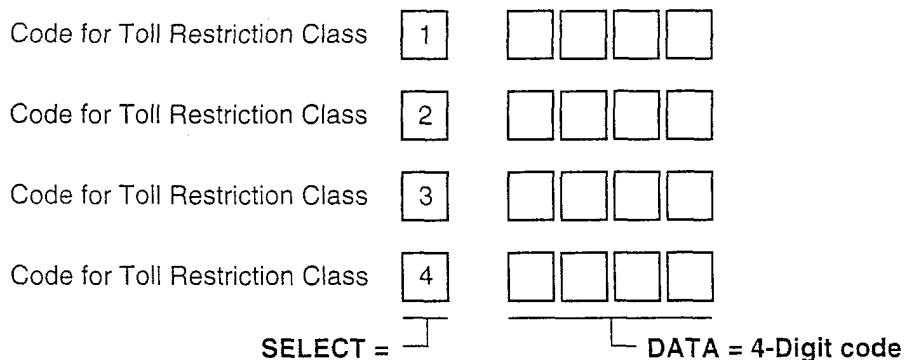
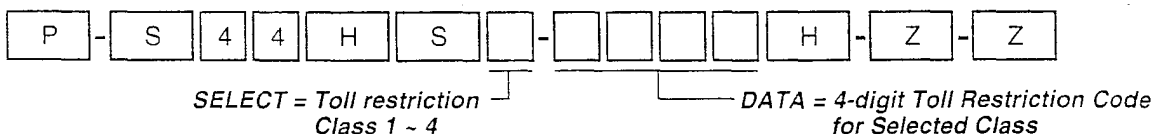
Electronic telephones can use the # button if they do not have the **Redial (RDL)** button.

#### NOTES:

1. The date, time and day can be set immediately following initialization or after programming is completed.
2. The system should not be in programming mode for the date, time and day to be set.

**PROGRAMMING PROCEDURES**  
**TOLL RESTRICTION SYSTEM RECORD SECTION**  
**Programs 44B ~ 48**

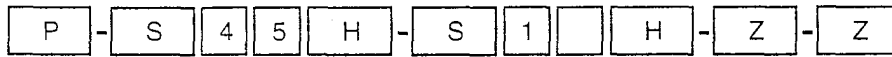
PROGRAM 44B  
 TOLL RESTRICTION/TRAVELING CLASS OVERRIDE CODES



NOTES:

1. For more information, see the instructions preceding the record sheets.
2. Classes 1 ~ 4 are defined in **Program 46**.
3. When the Toll Restriction override code is dialed, the station's class defined in **Program 48** will be changed to the class assigned to the code in **Program 44B**.
4. Do not use same codes set in **Program 45** (8 ~ 9).
5. Stations enabled in **Program 30**, Button/LED 16 ON, are allowed to enter and change Toll Restriction Class (1 ~ 4) override codes.

PROGRAM 45-1  
LCR/TOLL RESTRICTION DIAL PLAN



SELECT = 1

DATA = Plan 1 ~ 5

Enter codes 1 ~ 5 to indicate the dial plan for the system.

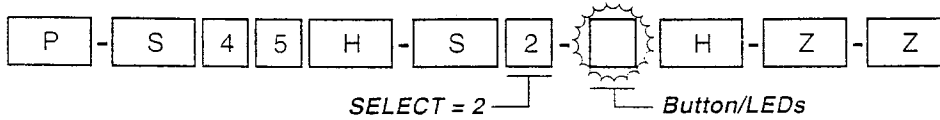
X	Plan	Toll Restriction/LCR Dial Plans
	5	0+ (Note 6)
	4	Universal (Note 6)
	3	1+AC+NXX/NNX
	2	1+AC+NXX/1+NNX (Note 7)
	1	AC+NXX/1+NNX (Note 7)

**IMPORTANT:** The correct Dial Plan must be assigned to allow system LCR and/or Toll Restriction to function properly.

**NOTES:**

1. Initialized data assigns Dial Plan Code 1 to the system.
2. In NXX and NNX, X = 0 ~ 9, N = 2 ~ 9.
3. NXX = Office code (interchangeable; 2nd digit can be 1 or 0).
4. NNX = Office code (**not** interchangeable; 2nd digit **cannot** be 1 or 0).
5. AC = Area Code.
6. 0+ and Universal (Codes 5 + 4) are not used in USA.
7. 1+ NNX indicates 1 may be dialed before office codes.

PROGRAM 45-2  
 TOLL RESTRICTION DISABLE



*Specify CO lines by setting button/LEDs as defined by the table below. All LEDs with an "X" should be lit when finished. ON = Disable Toll Restriction*

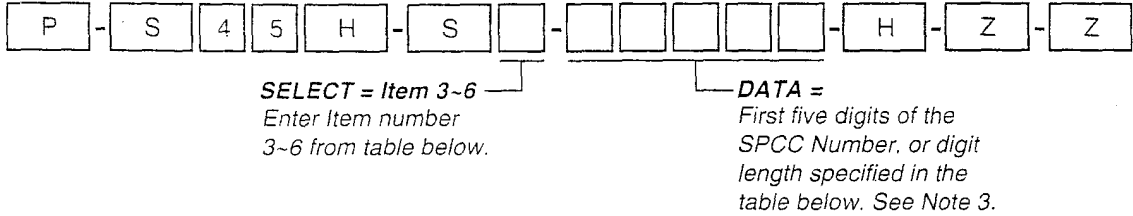
*NOTE: Shaded areas apply to DK16 only*

LED	CO Line	X
08	08	
07	07	
06	06	
05	05	
04	04	
03	03	
02	02	
01	01	

**NOTES:**

1. For more information, see the instructions preceding the record sheets.
2. Initialized data reads all LEDs OFF for all CO lines.

PROGRAM 45-3 ~ 6  
 EQUAL ACCESS/SPECIAL COMMON CARRIER (SPCC) NUMBERS AND AUTHORIZATION CODE DIGIT  
 LENGTH



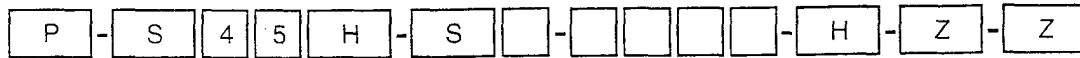
Item	Description	Data = 1st five digits of SPCC Number or Digit Length
3	SPCC1 Number	<input type="text"/> <input type="text"/> <input type="text"/> <input type="text"/> <input type="text"/>
4	Authorization Code 1 Digit Length (00 ~ 99)	<input type="text"/> <input type="text"/>
5	SPCC2	<input type="text"/> <input type="text"/> <input type="text"/> <input type="text"/> <input type="text"/>
6	Authorization Code 2 Digit Length (00 ~ 99)	<input type="text"/> <input type="text"/>

NOTES:

1. For more information, see the instructions preceding the record sheets.
2. Initialized data assigns "00" data to items 4 and 6, and assigns blank data to items 3 and 5.
3. When editing.
  - Press # to move cursor.
  - Press Button/LED 01 to delete or leave a blank.
  - Press Button/LED 02 for don't care.
4. Do not enter a digit length greater than necessary or Toll Restriction may be able to be defeated.
5. This program is designed for the following special Common Carrier access dialing sequence: SPCC Number + Authorization Code + Telephone Number (950XXXX). SMDR will print out the following: SPCC Number +----+ Telephone Number. (The Authorization Code will not print out, and four dashes ("----") will be in its place.) Toll Restriction will start on the first digit of the Telephone Number.



PROGRAM 45-8 ~ 9  
TOLL RESTRICTION OVERRIDE CODE



**SELECT = 8 or 9**  
Enter 8 to Select Code 1.  
Enter 9 to Select Code 2.

**DATA = Code**  
Enter the 4-digit code  
from the table below.

Select =		Code (4 digits)
8	Code 1	<input type="text"/> <input type="text"/> <input type="text"/> <input type="text"/>
9	Code 2	<input type="text"/> <input type="text"/> <input type="text"/> <input type="text"/>

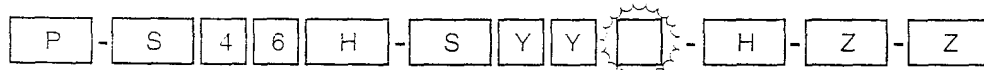
**NOTES:**

1. For more information, see the instructions preceding the record sheets.
2. When editing the data field, use Button/LED 01 to delete a digit; Button/LED 02 for don't care.
3. Initialized data leaves code assignments blank.
4. Codes may be revised by station users specified in **Program 30, LED 09**.
5. Do not use same 4-digit codes set in **Program 44B, Toll Restriction/Traveling Class (1 ~ 4) Override codes**. **Program 45 (8 ~ 9) overrides Program 44B (1 ~ 4)** if the same codes are used.





PROGRAM 46-10, -20, -30, -40  
TOLL RESTRICTION CLASS 1 PARAMETERS



**SELECT = YY**  
Enter the 2 digits on the dialpad which represent the class number :

- 10 = Class 1
- 20 = Class 2
- 30 = Class 3
- 40 = Class 4

**Button/LEDs**  
Light every button/LED marked with an X in the table below.

Copy as required for each Class (1 - 4).

LED	X	LED ON	LED OFF
20			
19			
18		Table 8 Area/Office Exception	Not Selected
17		Table 7 Area/Office Exception	Not Selected
16		Table 6 Area/Office Exception	Not Selected
15		Table 5 Area/Office Exception	Not Selected
14		Table 4 Area/Office Exception	Not Selected
13		Table 3 Area/Office Exception	Not Selected
12		Table 2 Area/Office Exception	Not Selected
11		Table 1 Area/Office Exception	Not Selected
10			
09			
08			
07			
06			
05			
04			
03		1 + A/C + 555/AC + 555 Allowed	Per Area Code Restriction
02		01 Restricted	Allowed
01		0 Restricted	Allowed

**NOTES:**

1. For more information, see the instructions preceding the record sheets.
2. Initialized data leaves all LEDs OFF.

**PROGRAM 47**  
**TOLL RESTRICTION EXCEPTION OFFICE CODES ASSIGNED BY AREA CODES**  
**(TABLES 1 AND 2)**

-           -       -  -  -

**SELECT = Exception Table 1 ~ 8**  
 Enter the number of the exception table. 1 ~ 8. A new exception table is needed for each area code with office codes that are exceptions to restriction.

**AREA CODE =**  
 Enter the area code.  
 See Note 3.

**SELECT = Exception Table 1 ~ 8**  
 Enter the number of the exception table, 1 ~ 8 again.

**DATA =**  
 Enter or display office code(s).  
 See Notes 4 and 5.

**2, 3 or 4**  
 Enter 2 to add to the exception table.  
 Enter 3 to delete from the exception table.  
 Enter 4# to display the exception table's office codes.

Exception Table (1 ~ 8)

Area Code

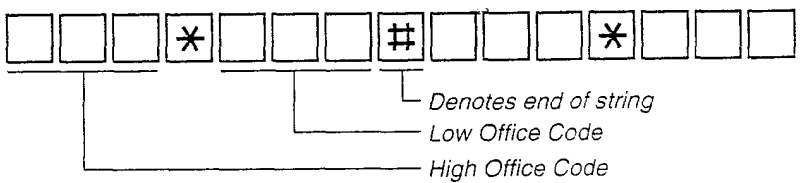
**Record of Exception Office Codes (Data)**


Exception Table (1 ~ 8)

Area Code

**Record of Exception Office Codes (Data)**


- NOTES:**
- For more information, see the instructions preceding the record sheets.
  - Initialized data assigns no office codes to tables.
  - Only one area code may be entered per exception table.
  - To enter a range of office codes, key in:    \*   #   \*
  - Several ranges or individual office codes may be entered by separating them with a # button.
  - Copy as required.  
maximum eight exception tables.



PROGRAM 48  
STATION TOLL RESTRICTION CLASSIFICATION

P - S 4 8 H - S   # -   - H - Z - Z

**SELECT = Logical Port Number(s)**  
Enter the port number(s) of the station(s) being defined.  
See Note 3 for entering a range.

**DATA =**  
**Digit Restriction Code 0 or 1**  
Enter 0 for no digit restriction.  
Enter 1 for digit restriction.

**Station Restriction Code (0 - 6)**  
Enter 0 for No Station Toll Restriction.  
Enter 1 for Area Code Toll Restriction.  
Enter 2 for Area Code Toll Restriction and 0 or 1 as 1st or 2nd digit.  
Enter 3 for Class 1 Toll Restriction.  
Enter 4 for Class 2 Toll Restriction.  
Enter 5 for Class 3 Toll Restriction.  
Enter 6 for Class 4 Toll Restriction.

NOTE: Shaded areas apply to DK16 only

Logical Port Number	Digit Restrict Code	Station Restrict Code
00		
01		
02		
03		
04		
05		
06		
07		
08		
09		
10 <sup>4</sup>		
11		
12		
13		
14		
15		
16		
17		
18		
19		
20 <sup>4</sup>		

NOTES:

- For more information, see the instructions preceding the record sheets.
- Initialized data reads "10" for all ports.

3. A range of ports may be entered:   \*

Low port in range | High port in range

- DK8, Port 10 and DK16, Port 20 assigns DISA CO lines to a Toll Restriction Classification.

**PROGRAMMING PROCEDURES**  
**LEAST COST ROUTING SYSTEM RECORD SECTION**  
**Programs 50 ~ 56**

### LCR CO LINE PROGRAMING

1) Use **Program 16** to assign CO lines in groups per the reference chart below.

**CO Line Group Reference Chart**

*NOTE: Shaded areas apply to DK16 only*

Line Group	CO Lines in Group (1 ~ 8)	CO Line Type/Comments
1 (81)		
2 (82)		
3 (83)		
4 (84)		
5 (85)		
6 (86)		
7 (87)		
8 (88)		

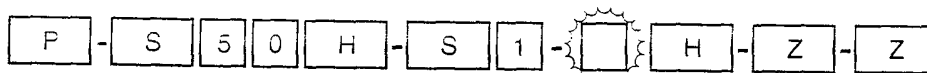
2) Use **Program 40** to allow CO lines access to stations using LCR for outgoing calls.

3) Use **Program 41** to deny outgoing CO line access except for LCR access.

**Important:** Area code and office code structure must be defined by **Program 45-1** (Toll Restriction Dial Plan) for LCR to work properly.

4) Use **Program 45-1** to enable the dial plan that is appropriate for the area where LCR calls will originate.

#### PROGRAM 50-1 LCR PARAMETERS



**SELECT = 1**

Press Button/LEDs for each LCR parameter.

LED	X	LED On	LED Off
1		Enable System LCR	No LCR
2		Not Used	Not Used
3		555 LDI Route Per Program 50-4	Per Area Code Table
4		Dial Tone After LCR Access	Silent
5		Warning Tone Last Choice Route No.	No Warning Tone

**NOTES:**

1. For more information, see the instructions preceding the record sheets.
2. **Program 40** denies CO line access via LCR and denies all other access methods.
3. **Program 41** allows CO line access via LCR but denies all other outgoing access methods: (CO line number 701 ~ 708, Pooled group 81 ~ 88, Line or Pooled Line Grp buttons).
4. Initialized data: All LEDs OFF.
5. To prevent Toll Restriction from being defeated because of K4RCU or QRCU time-out, Toll Restricted standard telephones should be forced to dial outgoing calls via LCR.



PROGRAM 50-2  
 LCR HOME AREA CODE

P	-	S	5	0	H	-	S	2				H	-	Z	-	Z
---	---	---	---	---	---	---	---	---	--	--	--	---	---	---	---	---

SELECT = 2

DATA = Home Area Code  
 Enter the local area code.

LCR Home Area Code

--	--	--

NOTES:

1. For more information, see the instructions preceding the record sheets.
2. Typically this code is entered in **Program 51** table for the LCR route plan number defined for the local calls in **Program 50-5**.
3. Initialized data leaves the home area code blank.

PROGRAM 50-31 ~ 35  
 LCR SPECIAL CODES

P	-	S	5	0	H	-	S			-				H	-	Z	-	Z
---	---	---	---	---	---	---	---	--	--	---	--	--	--	---	---	---	---	---

SELECT = 31 - 35  
 Enter 31 - 35 to indicate  
 the special code.

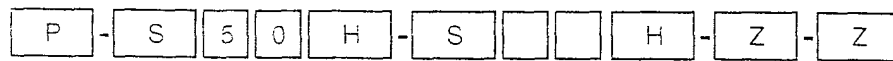
DATA = Special Code  
 Enter the code from the table below.

	Special Code	Examples				
31	<table border="1" style="border-collapse: collapse; width: 100%;"> <tr> <td style="width: 20px; height: 20px;"></td> <td style="width: 20px; height: 20px;"></td> <td style="width: 20px; height: 20px;"></td> <td style="width: 20px; height: 20px;"></td> </tr> </table>					1-411
32	<table border="1" style="border-collapse: collapse; width: 100%;"> <tr> <td style="width: 20px; height: 20px;"></td> <td style="width: 20px; height: 20px;"></td> <td style="width: 20px; height: 20px;"></td> <td style="width: 20px; height: 20px;"></td> </tr> </table>					911
33	<table border="1" style="border-collapse: collapse; width: 100%;"> <tr> <td style="width: 20px; height: 20px;"></td> <td style="width: 20px; height: 20px;"></td> <td style="width: 20px; height: 20px;"></td> <td style="width: 20px; height: 20px;"></td> </tr> </table>					611
34	<table border="1" style="border-collapse: collapse; width: 100%;"> <tr> <td style="width: 20px; height: 20px;"></td> <td style="width: 20px; height: 20px;"></td> <td style="width: 20px; height: 20px;"></td> <td style="width: 20px; height: 20px;"></td> </tr> </table>					
35	<table border="1" style="border-collapse: collapse; width: 100%;"> <tr> <td style="width: 20px; height: 20px;"></td> <td style="width: 20px; height: 20px;"></td> <td style="width: 20px; height: 20px;"></td> <td style="width: 20px; height: 20px;"></td> </tr> </table>					

NOTES:

1. For more information, see the instructions preceding the record sheets.
2. Initialized data leaves all codes blank.
3. Press Button/LED 01 to erase data and leave blank.
4. These calls follow the local call route defined in **Program 50-5**.

PROGRAM 50-4  
LCR LONG DISTANCE INFORMATION (LDI) PLAN NUMBER



SELECT = 4

DATA = LDI Route Plan (1 - 8)  
Identify the LDI Route Plan  
by entering 1 - 8.

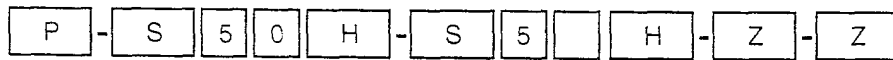
LDI Plan Number:

(1 - 8)

NOTES:

1. For more information, see the instructions preceding the record sheets.
2. Initialized data assigns LDI Plan Number 8.
3. Typically, LDI Plan Number = Local Call Plan Number.

PROGRAM 50-5  
LCR LOCAL CALL ROUTE PLAN NUMBER



SELECT = 5

DATA = Local Route Plan (1 - 8)  
Identify the Local Route Plan  
by entering 1 - 8.

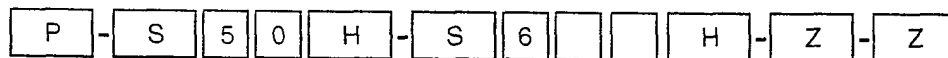
Local Call Plan Number:

(1 - 8)

NOTES:

1. For more information, see the instructions preceding the record sheets
2. Initialized data assigns Plan 8 to be the local call plan.
3. The local plan handles special codes and operator calls.

PROGRAM 50-6  
LCR DIAL ZERO TIMEOUT



SELECT = 6

DATA = Timeout Value  
Enter a timeout value from  
04 - 10 seconds long

Dial Zero Timeout:

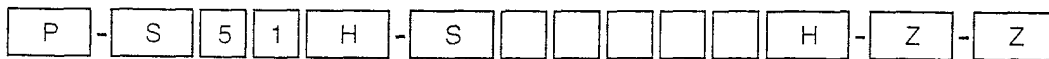
(04 - 10 seconds)

NOTES:

1. For more information, see the instructions preceding the record sheets.
2. Initialized data assigns an LCR Dial Zero Timeout value of 06.
3. This value determines pause time before sending a call on to an operator, etc.



**PROGRAM 51  
 LCR AREA CODES**



**SELECT = LCR**  
 Plan Number (1 - 8)

**Action Code:**  
 Enter 2 to add code to table.  
 Enter 3 to delete code from table.  
 Enter 4# to display codes in table.

**DATA = Area Code(s)**  
 (3 digits)

LCR Plan **5**          LCR Plan **6**          LCR Plan **7**          LCR Plan **8**  
 DATA = Area Code(s)    DATA = Area Code(s)    DATA = Area Code(s)    DATA = Area Code(s)

LCR Plan 5			LCR Plan 6			LCR Plan 7			LCR Plan 8		
DATA = Area Code(s)			DATA = Area Code(s)			DATA = Area Code(s)			DATA = Area Code(s)		
									000 ~ 999		

**NOTES:**

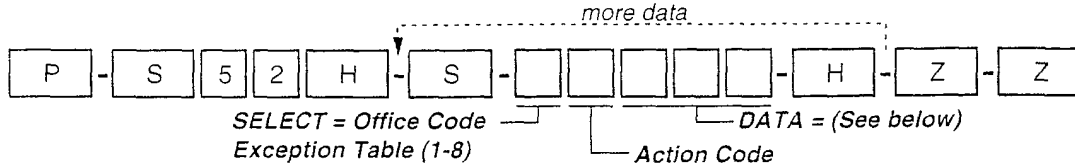
1. For more information, see the instructions preceding the record sheets.
2. Initialized data leaves Tables 1 ~ 7 blank; all codes (000 ~ 999) are initialized in Table 8.

3. To enter a range of Area Codes, press:    \*    #    \*     
 Low Area Code                      High Area Code                      Denotes end of string

4. Several ranges or individual codes can be expressed at once by separating them with a # button.

PROGRAM 52  
LCR OFFICE CODE EXCEPTIONS FOR SPECIFIED AREA CODE

To assign Office Code Exception Table (1 ~ 4) to an LCR Plan:



Action Code Function	Action Codes	DATA =
Assign Exception Table to LCR Plan	0	<input type="checkbox"/> LCR Plan 1 ~ 8
Assign Area Code to LCR Plan	1	<input type="checkbox"/> <input type="checkbox"/> <input type="checkbox"/> 3-digit Area Code
Add Office Codes to Exception Table	2	<input type="checkbox"/> <input type="checkbox"/> <input type="checkbox"/> 3-digit Office Code
Delete Office Codes from Exception Table	3	<input type="checkbox"/> <input type="checkbox"/> <input type="checkbox"/> 3-digit Office Code
Display Office Codes in Exception Table	4 # more #	<input type="checkbox"/> <input type="checkbox"/> <input type="checkbox"/> 3-digit Office Code

Office Code Exception Table  1 for Area Code

Assign to LCR Route Plan Number  Office Codes:


Office Code Exception Table  2 for Area Code

Assign to LCR Route Plan Number  Office Codes:


Office Code Exception Table  3 for Area Code

Assign to LCR Route Plan Number  Office Codes:


Office Code Exception Table  4 for Area Code

Assign to LCR Route Plan Number  Office Codes:


NOTES:

1. For more information, see the instructions preceding the record sheets.
2. Initialized data leaves all codes blank.

3. To enter a range of office codes, press:  \*  #  \*

Low Area Code

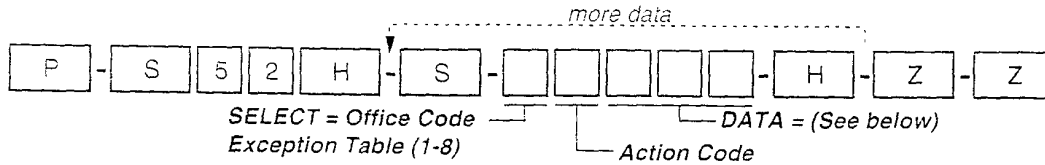
High Area Code

Denotes end of string

4. Several ranges or individual codes can be expressed at once by separating them with a # button.
5. Copy as required. maximum eight Office Code Exception Tables.

PROGRAM 51  
 LCR OFFICE CODE EXCEPTIONS FOR SPECIFIED AREA CODE

To assign Office Code Exception Table (5 ~ 8) to an LCR Plan:



Action Code Function	Action Codes	DATA =
Assign Exception Table to LCR Plan	<input type="text" value="0"/>	<input type="text"/> LCR Plan 1 ~ 8
Assign Area Code to LCR Plan	<input type="text" value="1"/>	<input type="text"/> <input type="text"/> <input type="text"/> 3-digit Area Code
Add Office Codes to Exception Table	<input type="text" value="2"/>	<input type="text"/> <input type="text"/> <input type="text"/> 3-digit Office Code
Delete Office Codes from Exception Table	<input type="text" value="3"/>	<input type="text"/> <input type="text"/> <input type="text"/> 3-digit Office Code
Display Office Codes in Exception Table	<input type="text" value="4"/> # more <input type="text"/>	<input type="text"/> <input type="text"/> <input type="text"/> 3-digit Office Code

Office Code Exception Table  for Area Code

Assign to LCR Route Plan Number  Office Codes:

<input type="text"/>	<input type="text"/>	<input type="text"/>	<input type="text"/>	<input type="text"/>	<input type="text"/>	<input type="text"/>	<input type="text"/>	<input type="text"/>	<input type="text"/>	<input type="text"/>	<input type="text"/>	<input type="text"/>	<input type="text"/>	<input type="text"/>	<input type="text"/>	<input type="text"/>	<input type="text"/>	<input type="text"/>	<input type="text"/>
<input type="text"/>	<input type="text"/>	<input type="text"/>	<input type="text"/>	<input type="text"/>	<input type="text"/>	<input type="text"/>	<input type="text"/>	<input type="text"/>	<input type="text"/>	<input type="text"/>	<input type="text"/>	<input type="text"/>	<input type="text"/>	<input type="text"/>	<input type="text"/>	<input type="text"/>	<input type="text"/>	<input type="text"/>	<input type="text"/>

Office Code Exception Table  for Area Code

Assign to LCR Route Plan Number  Office Codes:

<input type="text"/>	<input type="text"/>	<input type="text"/>	<input type="text"/>	<input type="text"/>	<input type="text"/>	<input type="text"/>	<input type="text"/>	<input type="text"/>	<input type="text"/>	<input type="text"/>	<input type="text"/>	<input type="text"/>	<input type="text"/>	<input type="text"/>	<input type="text"/>	<input type="text"/>	<input type="text"/>	<input type="text"/>	<input type="text"/>
<input type="text"/>	<input type="text"/>	<input type="text"/>	<input type="text"/>	<input type="text"/>	<input type="text"/>	<input type="text"/>	<input type="text"/>	<input type="text"/>	<input type="text"/>	<input type="text"/>	<input type="text"/>	<input type="text"/>	<input type="text"/>	<input type="text"/>	<input type="text"/>	<input type="text"/>	<input type="text"/>	<input type="text"/>	<input type="text"/>

Office Code Exception Table  for Area Code

Assign to LCR Route Plan Number  Office Codes:

<input type="text"/>	<input type="text"/>	<input type="text"/>	<input type="text"/>	<input type="text"/>	<input type="text"/>	<input type="text"/>	<input type="text"/>	<input type="text"/>	<input type="text"/>	<input type="text"/>	<input type="text"/>	<input type="text"/>	<input type="text"/>	<input type="text"/>	<input type="text"/>	<input type="text"/>	<input type="text"/>	<input type="text"/>	<input type="text"/>
<input type="text"/>	<input type="text"/>	<input type="text"/>	<input type="text"/>	<input type="text"/>	<input type="text"/>	<input type="text"/>	<input type="text"/>	<input type="text"/>	<input type="text"/>	<input type="text"/>	<input type="text"/>	<input type="text"/>	<input type="text"/>	<input type="text"/>	<input type="text"/>	<input type="text"/>	<input type="text"/>	<input type="text"/>	<input type="text"/>

Office Code Exception Table  for Area Code

Assign to LCR Route Plan Number  Office Codes:

<input type="text"/>	<input type="text"/>	<input type="text"/>	<input type="text"/>	<input type="text"/>	<input type="text"/>	<input type="text"/>	<input type="text"/>	<input type="text"/>	<input type="text"/>	<input type="text"/>	<input type="text"/>	<input type="text"/>	<input type="text"/>	<input type="text"/>	<input type="text"/>	<input type="text"/>	<input type="text"/>	<input type="text"/>	<input type="text"/>
<input type="text"/>	<input type="text"/>	<input type="text"/>	<input type="text"/>	<input type="text"/>	<input type="text"/>	<input type="text"/>	<input type="text"/>	<input type="text"/>	<input type="text"/>	<input type="text"/>	<input type="text"/>	<input type="text"/>	<input type="text"/>	<input type="text"/>	<input type="text"/>	<input type="text"/>	<input type="text"/>	<input type="text"/>	<input type="text"/>

NOTES:

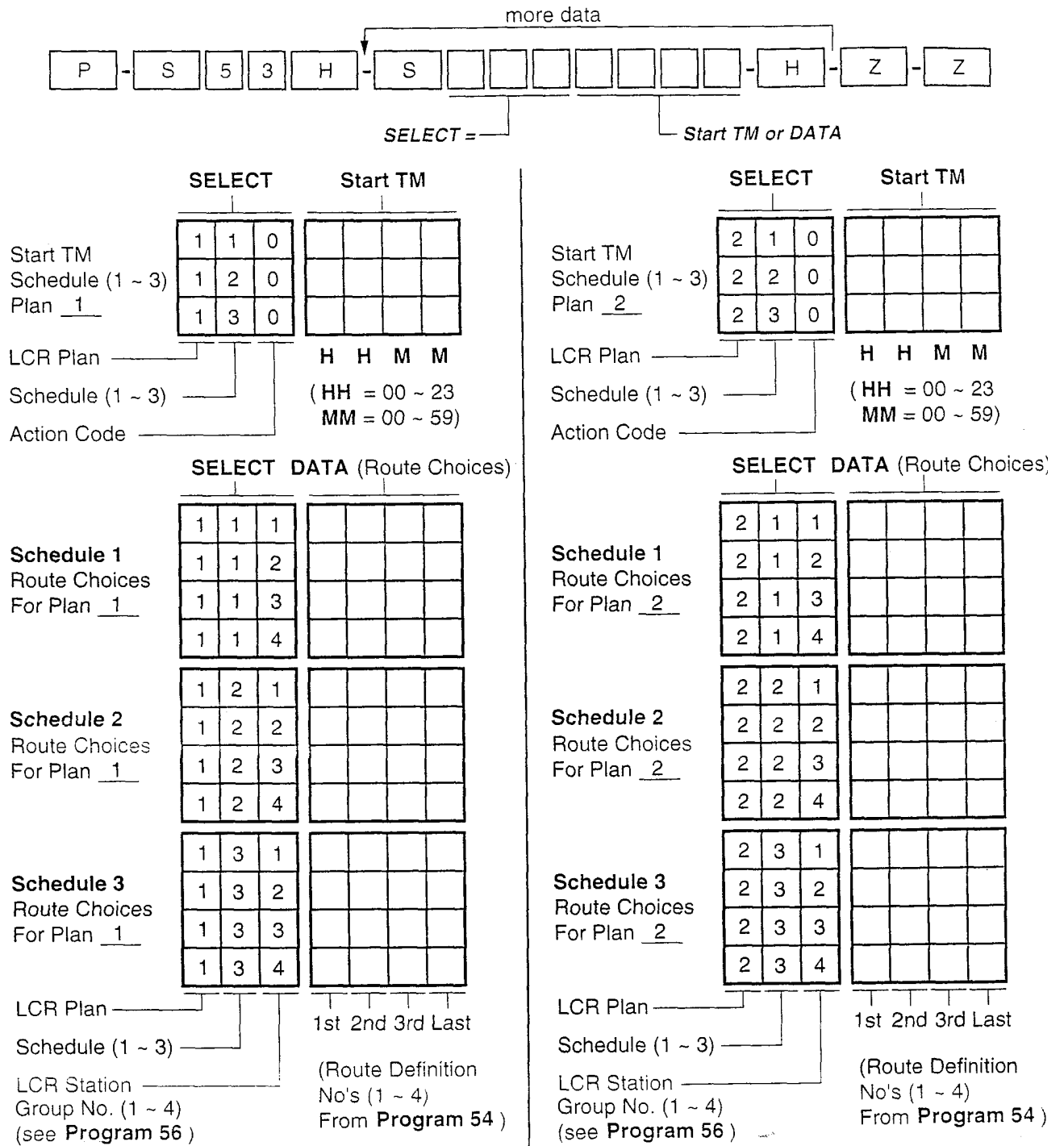
- For more information, see the instructions preceding the record sheets.
- Initialized data leaves all codes blank.

3. To enter a range of office codes, press: \*#\*

Low Area Code                      High Area Code                      Denotes end of string

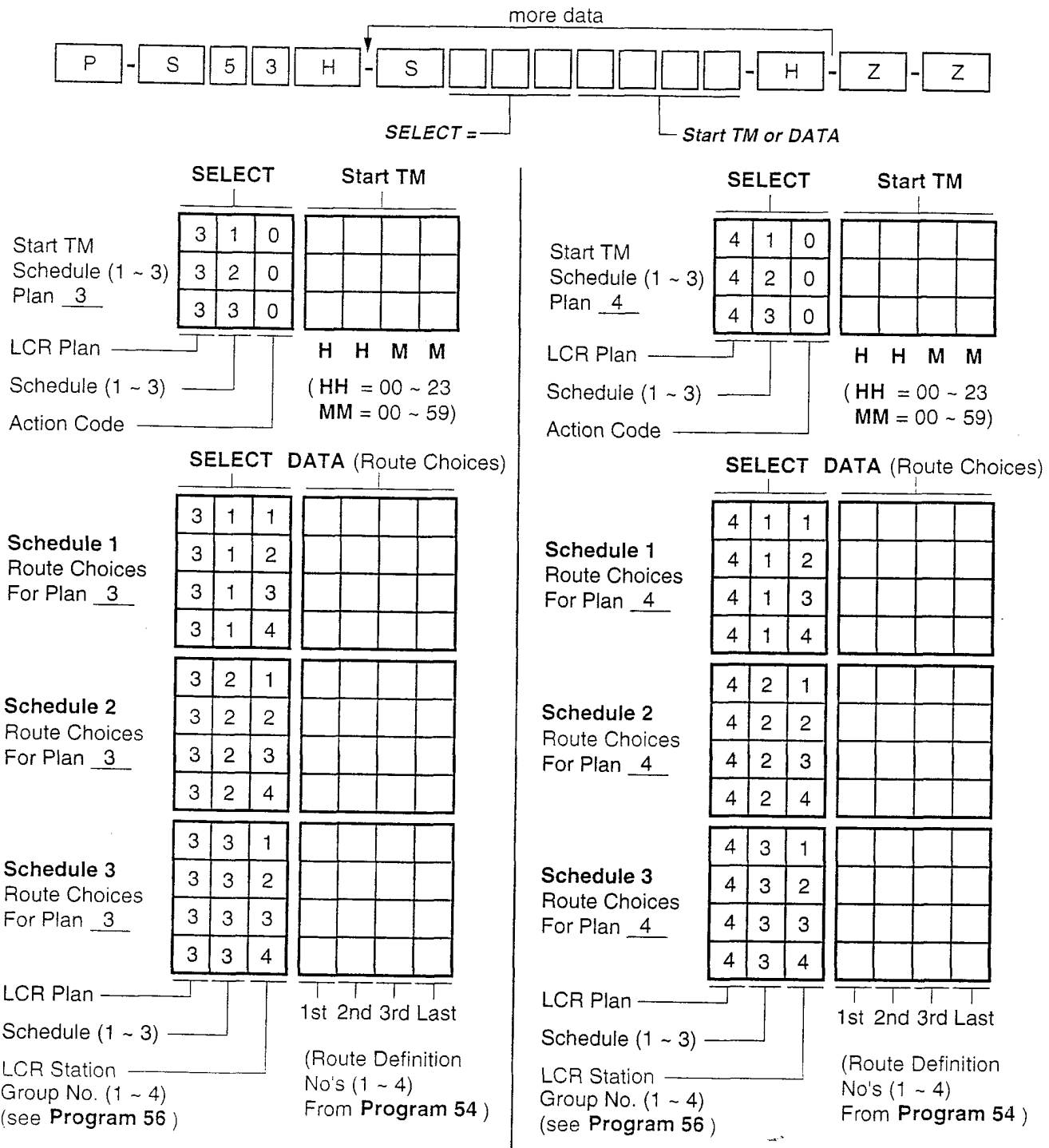
- Several ranges or individual codes can be expressed at once by separating them with a # button.

PROGRAM 53  
 LCR SCHEDULE ASSIGNMENTS  
 FOR LCR PLAN NO. 1 AND 2



- NOTES:**
1. For more information, see the instructions preceding the record sheets.
  2. Initialized data assigns starting time as 0000 and Route Definitions as blank for all schedules.
  3. If schedules 1 & 2 start at the same time, then Time of Day schedule change does not occur, and data only need to be entered for schedule 1.
  4. Press Button/LED 01 to erase data (LED does not light).

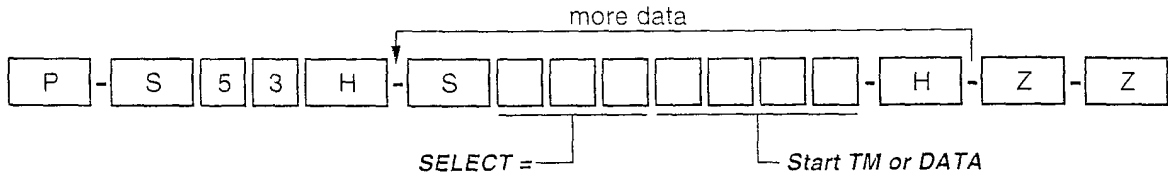
PROGRAM 53  
LCR SCHEDULE ASSIGNMENTS  
FOR LCR PLAN NO. 3 AND 4



- NOTES:
1. For more information, see the instructions preceding the record sheets.
  2. Initialized data assigns starting time as 0000 and Route Definitions as blank for all schedules.
  3. If schedules 1 & 2 start at the same time, then Time of Day schedule change does not occur, and data only needs to be entered for schedule 1.
  4. Press Button/LED 01 to erase data (LED does not light).



PROGRAM 53  
 LCR SCHEDULE ASSIGNMENTS  
 FOR LCR PLAN NO. 5 AND 6



	SELECT	Start TM
Start TM	5 1 0	
Schedule (1 ~ 3)	5 2 0	
Plan <u>5</u>	5 3 0	
LCR Plan		H H M M
Schedule (1 ~ 3)		(HH = 00 ~ 23 MM = 00 ~ 59)
Action Code		

	SELECT	Start TM
Start TM	6 1 0	
Schedule (1 ~ 3)	6 2 0	
Plan <u>6</u>	6 3 0	
LCR Plan		H H M M
Schedule (1 ~ 3)		(HH = 00 ~ 23 MM = 00 ~ 59)
Action Code		

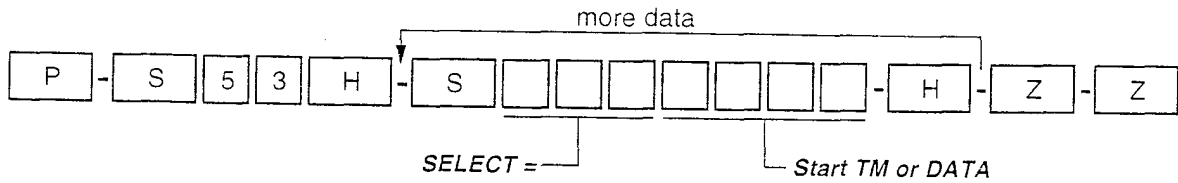
	SELECT	DATA (Route Choices)
Schedule 1 Route Choices For Plan <u>5</u>	5 1 1	
	5 1 2	
	5 1 3	
	5 1 4	
Schedule 2 Route Choices For Plan <u>5</u>	5 2 1	
	5 2 2	
	5 2 3	
	5 2 4	
Schedule 3 Route Choices For Plan <u>5</u>	5 3 1	
	5 3 2	
	5 3 3	
	5 3 4	
LCR Plan		1st 2nd 3rd Last
Schedule (1 ~ 3)		(Route Definition No's (1 ~ 4) From Program 54)
LCR Station Group No. (1 ~ 4) (see Program 56)		

	SELECT	DATA (Route Choices)
Schedule 1 Route Choices For Plan <u>6</u>	6 1 1	
	6 1 2	
	6 1 3	
	6 1 4	
Schedule 2 Route Choices For Plan <u>6</u>	6 2 1	
	6 2 2	
	6 2 3	
	6 2 4	
Schedule 3 Route Choices For Plan <u>6</u>	6 3 1	
	6 3 2	
	6 3 3	
	6 3 4	
LCR Plan		1st 2nd 3rd Last
Schedule (1 ~ 3)		(Route Definition No's (1 ~ 4) From Program 54)
LCR Station Group No. (1 ~ 4) (see Program 56)		

NOTES:

1. For more information, see the instructions preceding the record sheets.
2. Initialized data assigns starting time as 0000 and Route Definitions as blank for all schedules.
3. If schedules 1 & 2 start at the same time, then Time of Day schedule change does not occur, and data only needs to be entered for schedule 1.
4. Press Button/LED 01 to erase data (LED does not light).

PROGRAM 53  
LCR SCHEDULE ASSIGNMENTS  
FOR LCR PLAN NO. 7 AND 8



	SELECT			Start TM			
Start TM	7	1	0				
Schedule (1 ~ 3)	7	2	0				
Plan <u>7</u>	7	3	0				
LCR Plan				H	H	M	M
Schedule (1 ~ 3)				(HH = 00 ~ 23 MM = 00 ~ 59)			
Action Code							

	SELECT			Start TM			
Start TM	8	1	0				
Schedule (1 ~ 3)	8	2	0				
Plan <u>8</u>	8	3	0				
LCR Plan				H	H	M	M
Schedule (1 ~ 3)				(HH = 00 ~ 23 MM = 00 ~ 59)			
Action Code							

	SELECT			DATA (Route Choices)			
Schedule 1 Route Choices For Plan <u>7</u>	7	1	1				
	7	1	2				
	7	1	3				
	7	1	4				
Schedule 2 Route Choices For Plan <u>7</u>	7	2	1				
	7	2	2				
	7	2	3				
	7	2	4				
Schedule 3 Route Choices For Plan <u>7</u>	7	3	1				
	7	3	2				
	7	3	3				
	7	3	4				
LCR Plan				1st	2nd	3rd	Last
Schedule (1 ~ 3)				(Route Definition No's (1 ~ 4) From Program 54)			
LCR Station Group No. (1 ~ 4) (see Program 56)							

	SELECT			DATA (Route Choices)			
Schedule 1 Route Choices For Plan <u>8</u>	8	1	1				
	8	1	2				
	8	1	3				
	8	1	4				
Schedule 2 Route Choices For Plan <u>8</u>	8	2	1				
	8	2	2				
	8	2	3				
	8	2	4				
Schedule 3 Route Choices For Plan <u>8</u>	8	3	1				
	8	3	2				
	8	3	3				
	8	3	4				
LCR Plan				1st	2nd	3rd	Last
Schedule (1 ~ 3)				(Route Definition No's (1 ~ 4) From Program 54)			
LCR Station Group No. (1 ~ 4) (see Program 56)							

NOTES:

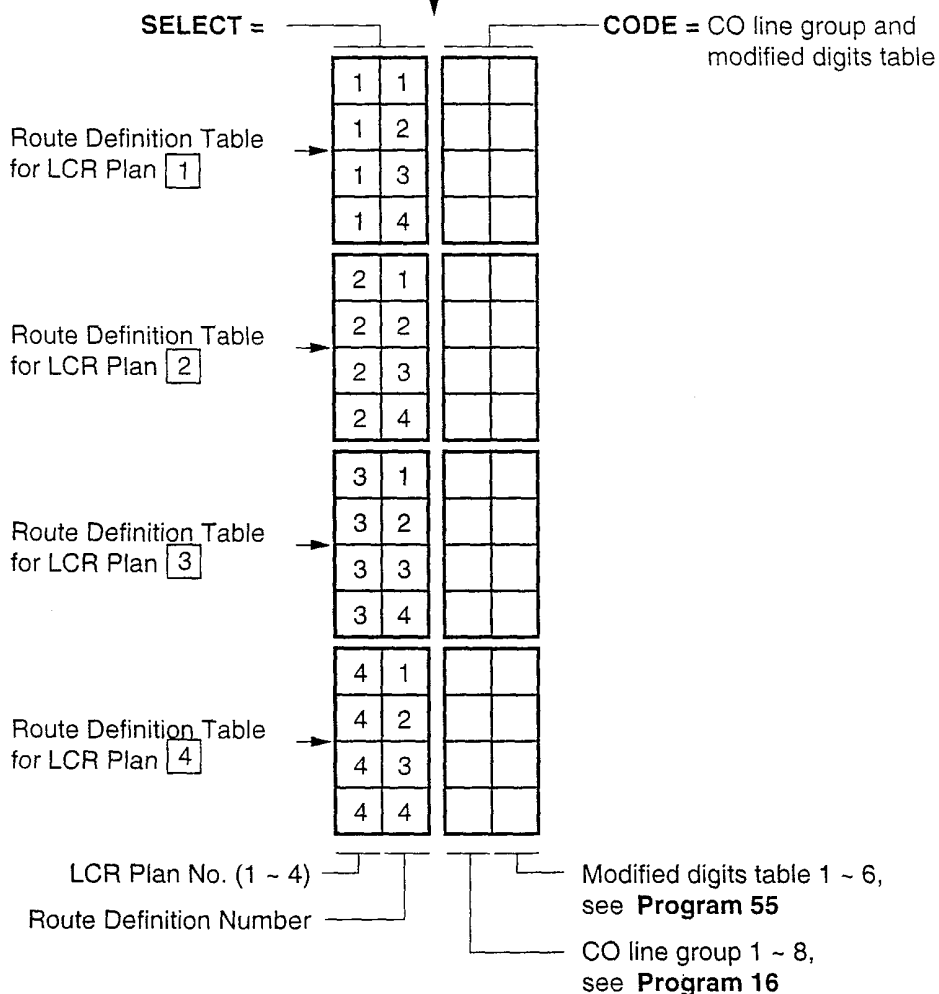
1. For more information, see the instructions preceding the record sheets.
2. Initialized data assigns starting time as 0000 and Route Definitions as blank for all schedules.
3. If schedules 1 & 2 start at the same time, then Time of Day schedule change does not occur, and data only needs to be entered for schedule 1.
4. Press Button/LED 01 to erase data (LED does not light).

PROGRAM 54  
 LCR ROUTE DEFINITION TABLES (1 ~ 4)



SELECT = \_\_\_\_\_ CODE = \_\_\_\_\_

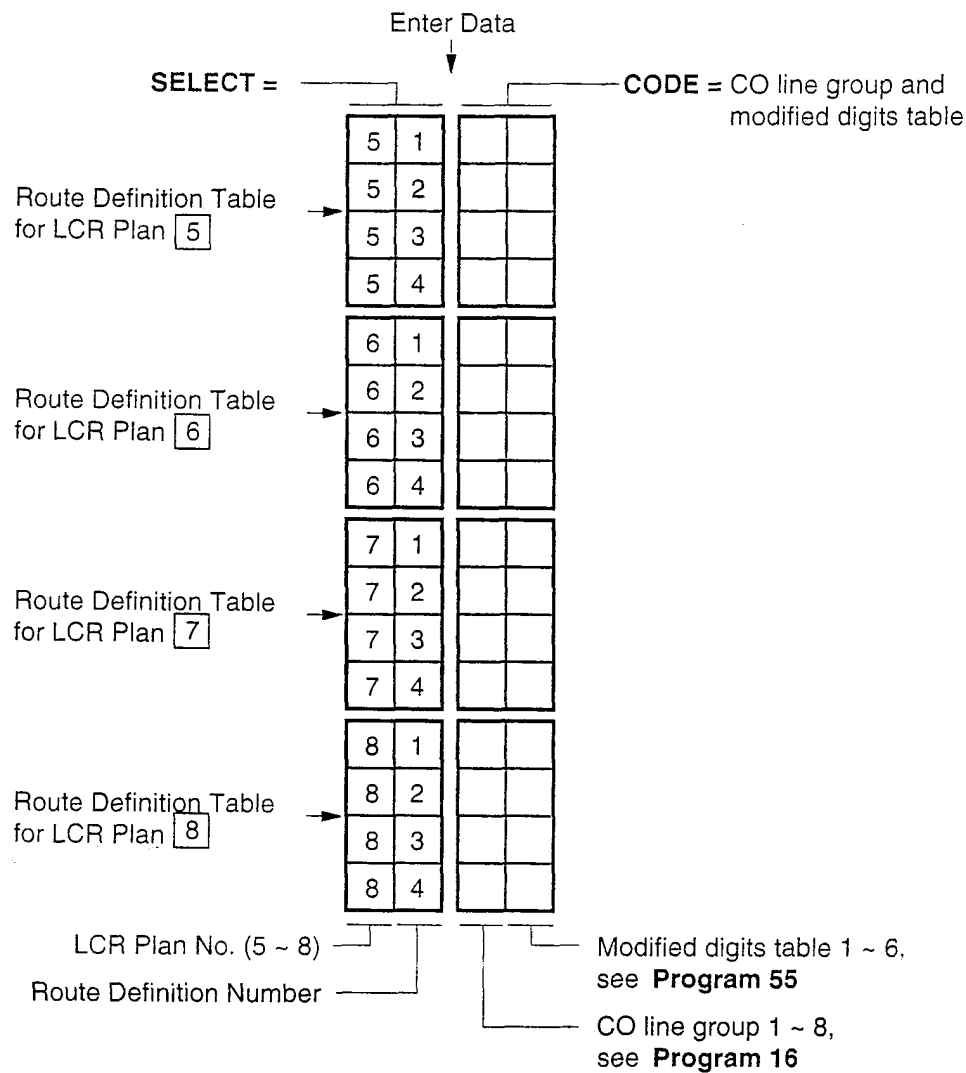
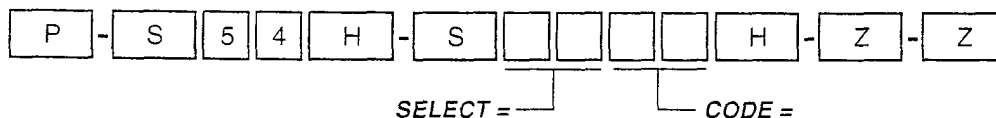
Enter Data



NOTES:

1. For more information, see the instructions preceding the record sheets.
2. Initialized data is "11".

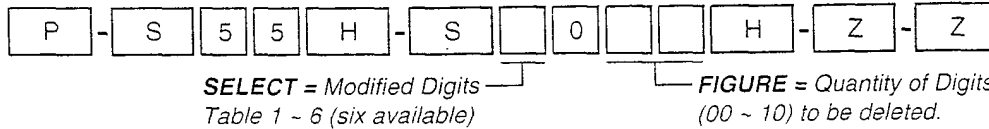
PROGRAM 54  
 LCR ROUTE DEFINITION TABLES (5 ~ 8)



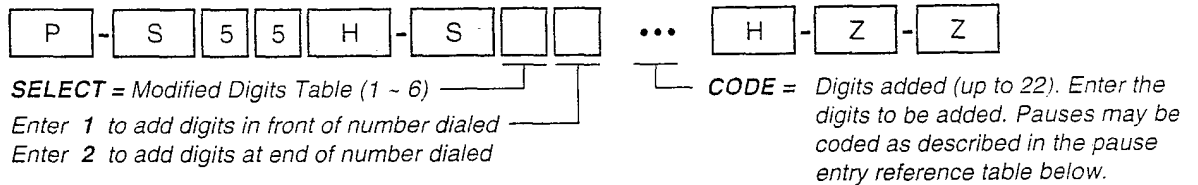
- NOTES:
- For more information, see the instructions preceding the record sheets.
  - Initialized data is "11".

PROGRAM 55  
 LCR MODIFIED DIGITS TABLES

PROGRAM 55-0 LCR MODIFIED DIGITS - DELETE FROM FRONT



PROGRAM 55-1 and 2 LCR MODIFIED DIGITS - ADD



DELETE DIGITS TABLES

Table No.	Quantity of Digits
1	
2	
3	
4	
5	
6	

Quantity 10 Max. (00 ~ 10)

PAUSE ENTRY REFERENCE  
 (Program 55-1, 55-2)

Key/LED	Pause (Seconds)	Record Entry
08	16	P8
07	14	P7
06	12	P6
05	10	P5
04	8	P4
03	6	P3
02	4	P2
01	2	P1

Special Keys:

- Key/LED  
 11 - Clear  
 10 - Convert DP to DTMF

ADD DIGIT TABLES

Add to FRONT of Dialed Number (Program 55-1)

Table No.	1	2	3	4	5	6	7	8	9	10	11	12	13	14	15	16	17	18	19	20	21	22	Comments	
1																								
2																								
3																								
4																								
5																								
6																								

Add to END of Dialed Number (Program 55-2)

Table No.	1	2	3	4	5	6	7	8	9	10	11	12	13	14	15	16	17	18	19	20	21	22	Comments	
1																								
2																								
3																								
4																								
5																								
6																								

NOTES:

1. For more information, see the instructions preceding the record sheets.
2. Initialized data leaves all tables blank except Delete Digits, which are all 00.

PROGRAM 56  
LCR STATION GROUP ASSIGNMENT

-     -    #    -  -

**SELECT = Logical Port number(s)** Enter LCR station Group (1 - 4)  
 Enter port numbers of stations being assigned.  
 See Note 3 for entering a range of ports.

NOTE: Shaded areas apply to DK16 only

Logical Port Number	LCR Station Group No. (1 ~ 4)
00	
01	
02	
03	
04	
05	
06	
07	
08	
09	
10	
11	
12	
13	
14	
15	
16	
17	
18	
19	

NOTES:

- For more information, see the instructions preceding the record sheets.
- Initialized data assigns all stations to group 1.

3. To enter a range of ports, press:   \*

Low port
High port

- Refer to Program 53.

**PROGRAMMING PROCEDURES-INSTRUCTIONS/SYSTEM RECORDS**  
**SECTION 100-816-302**  
**MARCH 1993**

*This table below shows the program options for stations and CO lines for verified, forced and voluntary account code dialing.*

**TABLE 2-B**  
**ACCOUNT CODE PROGRAM OPTION MATRIX**

Account Code Program Options			
	Station		CO Line
Account Code Dial Plan	Verified Program 30 LED 14	Forced Program 30 LED 08	Forced Program 15-7 CO LED
Verified (Forced)	On	On	On
Verified (Voluntary)	On	On	Off
Verified (Voluntary)	On	Off	On
Verified (Voluntary)	On	Off	Off
Not Verified (Forced)	Off	On	On
Not Verified (Voluntary)	Off	On	Off
Not Verified (Voluntary)	Off	Off	On
Not Verified (Voluntary)	Off	Off	Off

— System Initialization

TABLE 2-C  
OVERRIDE OPTION MATRIX

Station A May Override Station B <sup>1</sup>		Privacy Override Station A Options Program 30 <sup>3</sup> LED 19	Privacy Override Block Station B Options Program 31 LED 18	Station B Button Options (Program 39)	
				Privacy on Line <sup>2</sup> Button	Privacy Release <sup>2</sup> Button
Executive <sup>3</sup>	Privacy				
Yes	No	Off	Off	Off	Off
Yes	Yes	Off	Off	Off	On
Yes	No	Off	Off	On	Off
Yes	Yes	Off	Off	On	On
No	No	Off	On	Off	Off
No	Yes	Off	On	Off	On
No	No	Off	On	On	Off
No	Yes	Off	On	On	On
Yes	Yes	On	Off	Off	Off
Yes	Yes	On	Off	Off	On
Yes	No	On	Off	On	Off
Yes	Yes	On	Off	On	On
No	No	On	On	Off	Off
No	Yes	On	On	Off	On
No	No	On	On	On	Off
No	Yes	On	On	On	On

**NOTES:**

1. **Station "A"** attempts to override (*Executive or Privacy*) **Station "B"**.
2. Normally, either the *Privacy on Line* or *Privacy Release* button, not both, is assigned to a telephone (**Program 39**) depending on how it should operate with Privacy Override.
3. **Program 30**, Button/LED 18 is turned ON for **Station A**, allowing **Station A** to have Executive Override to **Station B** for some possibilities in this table. If **Program 30**, LED 18 is OFF for Station A, then it can never Executive Override any station.



***Strata***<sup>®</sup> *DK8&DK16*

**FAULT FINDING PROCEDURES**

TABLE OF CONTENTS

PARAGRAPH	SUBJECT	PAGE
1	GENERAL .....	1
2	FAULT CLASSIFICATION .....	1
3	FAULT CLEARING PROCEDURES .....	1
4	DEFECTIVE APPARATUS RETURNS .....	2
5	FAULT IDENTIFICATION AND ELIMINATION PROCEDURES .....	2
6	DK8 HARDWARE FAULT ISOLATION .....	2
7	DK16 HARDWARE FAULT ISOLATION .....	4
8	STATION CABLE CONTINUITY CHECK .....	4
8.01	Voltmeter Test .....	4
8.10	Ohmmeter Test .....	5
8.20	Cable Installation .....	5
9	FAULT ISOLATION FLOWCHARTS .....	5
	FLOWCHARTS .....	7
	CHART NO. 1 — FAULT CLASSIFICATION .....	7
	CHART NO. 2 — CATASTROPHIC FAULTS .....	8
	CHART NO. 3 — STATION DIAL TONE FAULTS .....	9
	CHART NO. 4 — CO DIAL TONE FAULTS .....	10
	CHART NO. 5 — DSS CONSOLE FAULTS .....	11
	CHART NO. 6 — VOICE MAIL/(EXTERNAL) AUTO ATTENDANT FAULTS .....	12
	CHART NO. 7 — STATION MESSAGE DETAIL RECORDING FAULTS .....	13
	CHART NO. 8 — REMOTE MAINTENANCE FAULTS .....	14

TABLE LIST

TABLE	TITLE	PAGE
A	FLOWCHARTS .....	1
B	STATION CABLE CONTINUITY CHECK USING VOLTMETER .....	6
C	STATION CABLE CONTINUITY CHECK USING OHMMETER .....	6
D	STATION CABLE CONTINUITY CHECK USING VOLTMETER .....	6
E	STATION CABLE CONTINUITY CHECK USING OHMMETER .....	6

FIGURE LIST

FIGURE	TITLE	PAGE
1	FLOWCHART SYMBOLS .....	1
2	QPSU8 DC VOLTAGE TEST .....	3
3	KPSU16 DC VOLTAGE TEST .....	3

## 1 GENERAL

1.01 This section describes the maintenance procedures used to diagnose faults in the STRATA DK8 and DK16 digital key telephone system. Faults are classified and then cleared by replacing the malfunctioning unit and performing operational tests in the sequences prescribed by the fault clearing flowcharts in Paragraph 9.

## 2 FAULT CLASSIFICATION

2.01 A Fault Classification Flowchart is provided to ensure that fault clearing is pursued in a logical sequence (Chart No. 1).

2.02 An assumption is made in the flowcharts that the fault was discovered and reported by a digital or electronic telephone user. All faults, therefore, are classified according to the way they would appear at the digital or electronic telephone.

2.03 Faults and associated flowcharts in Table A are organized into the following categories:

**TABLE A  
FLOWCHARTS**

Flowchart	Title
1	Fault Classification
2	Catastrophic Faults
3	Station Dial Tone Faults
4	CO Line Dial Tone Faults
5	DSS Console Faults
6	Voice Mail/(External) Auto Attendant (VM/AA) Faults
7	Station Message Detail Recording (SMDR) Faults
8	Remote Maintenance Faults

## 3 FAULT CLEARING PROCEDURES

3.01 Before attempting to clear any fault, ensure that it is in the system and not caused by associated external equipment, such as wiring, MOH source, etc.

### **IMPORTANT!**

*Many system features are assigned, enabled or disabled using software entries*

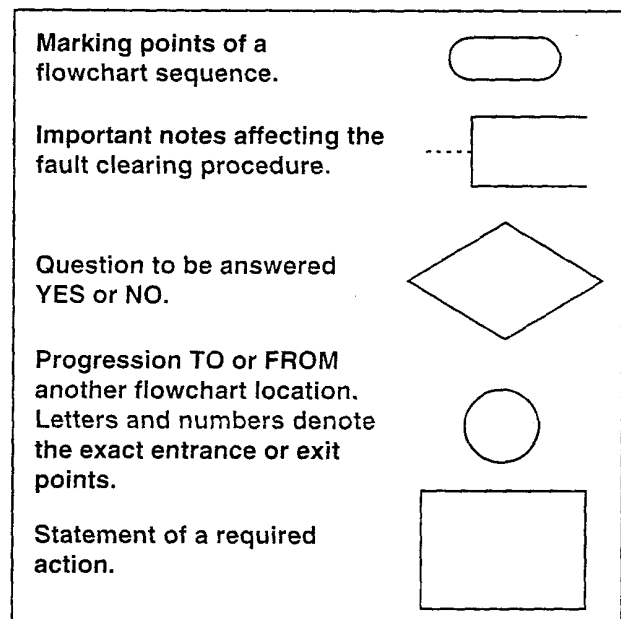
*as described in Programming Procedures. It is very important to verify that the system programming is correct and functional before troubleshooting the hardware.*

3.02 Initialize the system (**Program 90, 92, and 03**) before testing new systems or when in DK16 cases., changing the KFCU, Feature cartridge (if instructions specify).

3.03 Faults in the DK8 and DK16 are cleared by replacing PCBs, telephones (digital or electronic) or the power supply, as instructed in the flowcharts.

3.04 Five symbols are used in the flowcharts, which are identified in Figure 1.

3.05 The flowcharts are sequentially arranged to permit rapid fault localization within the system. *All fault clearing must begin with the Fault Classification Flowchart*, which is arranged in the correct fault locating sequence.



**FIGURE 1  
FLOWCHART SYMBOLS**

3.06 The following precautions must be observed when handling PCBs:

**DO NOT:**

- Drop a PCB.
- Stack one PCB on top of another.
- Handle a PCB without discharging any static electricity from your person by touching the grounded cabinet.
- Touch PCB contacts with your fingers.

***Important!***

***If the fault is not cleared by substituting a PCB, the original PCB must be reinstalled in the KSU before trying another PCB.***

#### **4 DEFECTIVE APPARATUS RETURNS**

**4.01** When a defective system apparatus is shipped for repair, the apparatus must be packed in a suitable container (the original box is highly recommended), as follows:

- a) Anti-static containers for all other PCBs and Feature cartridge.
- b) Plastic bags for digital or electronic telephones, KSU, etc.

**4.02 NEVER WRITE ON THE APPARATUS ITSELF!** Describe the nature of the defect on an information tag. Attach the tag to the front of the unit with string (not wire) so the tag can remain attached during the testing and repair process. Return tags are available from Toshiba America Information Systems, Inc., TSD Division.

#### **5 FAULT IDENTIFICATION AND ELIMINATION PROCEDURES**

**5.01** The DK8 or DK16, KSU common control circuits or DK16 KFCU may contain a "soft" fault due to an extremely high level of static electricity. If it is found defective during the fault finding procedures, attempt to clear a soft fault prior to returning the KSU or KFCU for repair. The correct procedure for this is to perform the initialization procedure, and then re-program the system as necessary to test for the fault. If the fault returns after these procedures are performed, tag the defective KSU or KFCU and return it for repair.

#### **6 DK8 HARDWARE FAULT ISOLATION**

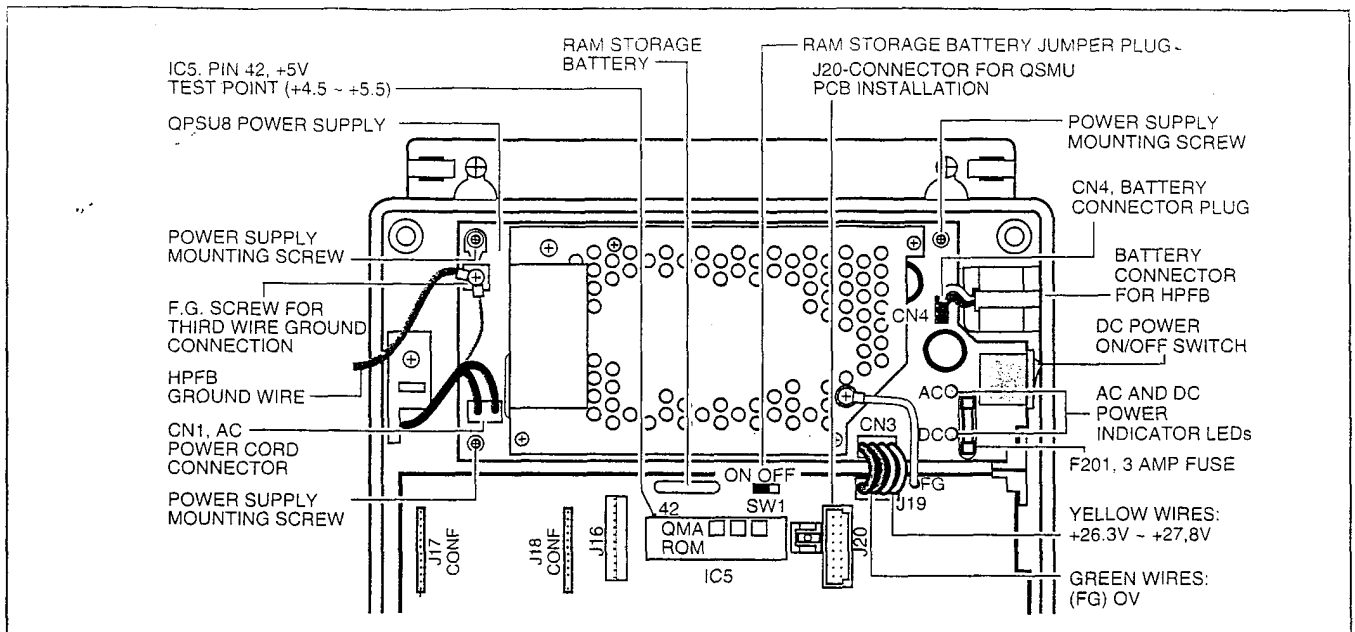
**6.01** If a DK8 hardware fault is suspected, check

the hardware using the following procedure.

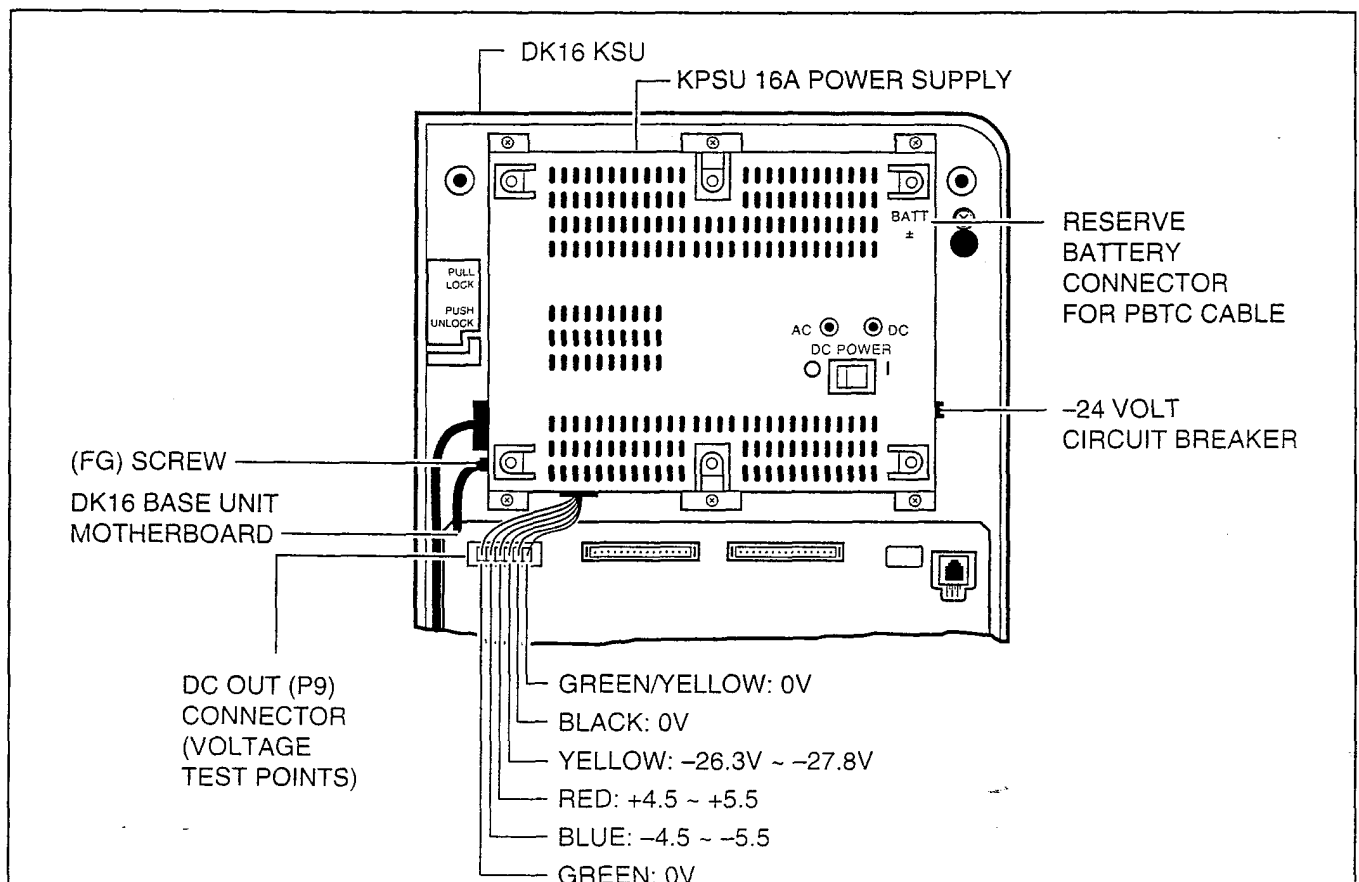
- 1) Make sure the BATT jumper plug (SW1 on the KSU motherboard) is in the ON position to save the system's customer data base.
- 2) Unplug HPFB battery cable from BATT connector on QPSU8 Power Supply (see Figure 2).
- 3) Remove all piggy-back PCBs from the DK8 motherboard one at a time. Retest to check if the problem is cleared each time a PCB is removed. If it is found that a particular PCB is causing the problem, replace that PCB and retest (piggy-back PCBs include QSTU, QCDU, QRCU, QCNU, and QSMU).
- 4) Test power supply as follows (refer to Figure 2):
  - a) Plug the AC power cable into an outlet.
    - The "AC" LED on the power supply should light green.
  - b) Turn the power supply switch to the ON position.
    - The "DC" LED on the power supply should light green.
  - c) Using the voltmeter, measure the voltages referenced to frame ground (FG) at the power supply connector CN3 pins (test points) and pin 42 of IC5 located on the motherboard (Figure 2). The voltages should fall within the ranges below. If the voltages do not fall within the range, unplug the DC power pins from power supply connector CN3 and measure +24V again at the same location; if the voltages remain unacceptable, replace the power supply (see Section 100-816-204).
    - J19 Green Wires: 0V
    - J19 Yellow Wires: +24V
      - Range: +26.3V ~ +27.8V
    - IC5, Pin 42, +5V
      - Range: +4.5V ~ +5.5V
  - d) If the +24V tests within range but +5V is not within specification, the KSU must be replaced.

***Important Note:***

***Do not attempt to replace Fuse F201***



**FIGURE 2**  
**QPSU8 DC VOLTAGE TEST**



**FIGURE 3**  
**KPSU16 DC VOLTAGE TEST**

## 7 DK16 HARDWARE FAULT ISOLATION

**7.01** If a DK16 hardware fault is suspected, check the hardware using the following procedure:

- 1) Make sure the BATT jumper plug (SW1 on the base unit motherboard) is in the ON position to save the system's customer data base.
- 2) Unplug the PBTC battery cable from BATT connector on KPSU16 Power Supply (see Figure 2).
- 3) Lightly press the -24V circuit breaker to ensure it has not opened (Figure 3). If the circuit breaker has opened and will not rest, remove assemblies (KSTU, KCOU, Expansion Unit PCBs, Expansion Unit) one at a time and try to reset -24V circuit breaker. If it is found that one of the removable assemblies causes the circuit breaker to open, replace that assembly. (See Section **100-816-205** for PCB removal and Expansion Unit installation and removal.)
  - a) If the -24V circuit breaker cannot be reset with all removable assemblies disconnected, disconnect the DC OUT connect (P9) from the Base unit motherboard and try to reset the -24V breaker.
  - b) If the circuit breaker resets when the DC OUT connector is removed, the Base Unit or Power Supply may be defective. Replace the Power Supply first (per Section **100-816-205**) to avoid reprogramming the system.
  - c) If the -24V breaker continues to open ;after the power Supply is replaced, install the original Power supply onto the DK16 Key Service Unit (KSU) and replace the KSU with another KSU.
- 4) If the -24V circuit breaker is not open (Step 3) check the Power Supply DC voltages as follows:

Using a voltmeter or other device which checks voltage, measure the voltages referenced to frame ground (FG) at the DC OUT connector

pins (test points) located on the motherboard (Figure 2). The voltages should fall within the ranges below. If the voltages do not fall within the ranges, unplug the DC power pins from the DC OUT connector and measure again at the same location; if the ranges remain unacceptable, replace the Power Supply.

- (FG) Yellow-Green Wire: 0V
  - Yellow Wire: - 24V
    - Range: -26.3V ~ -27.8V
  - Red Wire: 5V
    - Range: 4.5V ~ 5.5V
  - Blue Wire: -5V
    - Range: -4.5V ~ -5.5V
- 4) Check system third wire ground per Section **100-816-202**.
  - 5) If the -24V circuit breaker, DC power, and third wire ground are within required limits, remove all hardware assemblies, one at a time, and test to see if the fault is cleared (remove KSTU, KCOU, K4RCU and Expansion Unit PCBs and remove Expansion Unit per Section **100-816-205**).
  - 6) If the above hardware check did not clear the fault, call your Technical Support Group.

## 8 STATION CABLE CONTINUITY CHECK

### 8.01 Voltmeter Test

**8.02** The continuity of the cable run between the DK16 KSU and the digital or electronic telephone is checked with a voltmeter as follows:

**NOTE:**

*Perform the following at the locations indicated:*

1. *Modular block: Check all stations cables.*
2. *MDF: Check cable from KSU to MDF.*
3. *These tests also apply for troubleshooting cable problems with DDCB and PDIU-DS devices.*
4. *Refer to Section **100-816-208** for appropriate MDF wiring diagrams.*

- 1) Disconnect the digital or electronic telephone.

- 2) Using a DC voltmeter, measure between the wires of the two pairs to verify the readings shown in Table B for electronic telephone ports (PEKU or PESU). Refer to Table D for digital telephone ports. The reading will be a plus or minus depending on meter lead placement.
- 3) An improper reading indicates an open, crossed or shorted wire.
- 4) For the MDF-to-telephone (digital or electronic) cable, a more precise check is made using an ohmmeter.

#### 8.10 Ohmmeter Test

8.11 The continuity of the cable run between the KSU and digital or electronic telephone is checked with an ohmmeter as follows:

- 1) Disconnect the electronic or digital telephone.
- 2) At the MDF, remove the bridging clips.
- 3) At the MDF, place shorting jumper wires between the T and R of pair #1 (green-red), the T and R of pair #2 (black-yellow) and the T and R of OCA pair #3 (blue-white), for PEKU/PESU only. (For MDF pin numbers, see Section 100-816-208.)
- 4) At the modular block, measure the resistance between all wire combinations. The proper readings are shown in Table C for electronic telephones and HDSSs, and Table E for digital telephones, DDSSs and DDCBs.

#### 8.20 Cable Installation

8.21 If cable voltmeter and ohmmeter tests are within limits, digital telephones may not operate because of the following:

- 1) Digital telephone cable runs must be free of cable splits (single or double). Test for and eliminate all cable splits.
- 2) Cable bridge taps – Digital telephones will

not operate if cable runs contain any type (short or long) of cable bridge. Test for and eliminate all cable bridges.

- 3) When installing the station cable, do not run parallel to and within 3 feet of an AC power line. AC power lines should be crossed at right (90°) angles only. In particular, avoid running station wire pairs near devices that generate electrical noise, such as neon or fluorescent light fixtures.
- 4) Check Table 8-D, in Section 100-816-208. Verify that your telephone is wired correctly (2-pair or External power) for the options it supports (ADM, PDIU-DI, HHEU, DVSU, etc.).

### 9 FAULT ISOLATION FLOW CHARTS

9.01 The following troubleshooting flow charts are available to aid in fault isolation. It is recommended to read paragraph 1~5 of this section and then proceed to CHART 1, page 7, to begin fault isolation.

**TABLE B  
(ELECTRONIC TELEPHONE CABLES)  
STATION CABLE CONTINUITY  
CHECK USING VOLTMETER**

FROM			TO			VOLTAGE <sup>3</sup>
Pair	Wire	Color	Pair	Wire	Color	
1	T	Green	2	T	Black	24 <sup>3</sup>
1	R	Red	2	T	Black	24 <sup>3</sup>
1	T	Green	2	R	Yellow	24 <sup>3</sup>
1	R	Red	2	R	Yellow	24 <sup>3</sup>
1	T	Green	1	R	Red	0
2	T	Black	2	R	Yellow	0
3	T	White	3	R	Blue	0
3	T	White	1	R	Red	0
3	R	Blue	1	R	Red	0
3	T	White	1	T	Green	0
3	R	Blue	1	T	Green	0
3	T	White	2	T	Black	0
3	R	Blue	2	T	Black	0
3	T	White	2	R	Yellow	0
3	R	Blue	2	R	Yellow	0

**TABLE C  
(ELECTRONIC TELEPHONE CABLES)  
STATION CABLE CONTINUITY  
CHECK USING OHMMETER**

FROM			TO			Resistance
Pair	Wire	Color	Pair	Wire	Color	
1	T	Green	2	T	Black	open
1	R	Red	2	T	Black	open
1	T	Green	2	R	Yellow	open
1	R	Red	2	R	Yellow	open
1	T	Green	1	R	Red	40 ohms <sup>1</sup>
2	T	Black	2	R	Yellow	40 ohms <sup>1</sup>
3	T	White	3	R	Blue	40 ohms <sup>1</sup>
3	T	White	1	R	Red	open
3	R	Blue	1	R	Red	open
3	T	White	1	T	Green	open
3	R	Blue	1	T	Green	open
3	T	White	2	T	Black	open
3	R	Blue	2	T	Black	open
3	T	White	2	R	Yellow	open

**TABLE D  
(DIGITAL TELEPHONE CABLES)  
STATION CABLE CONTINUITY  
CHECK USING VOLTMETER**

FROM			TO			VOLTAGE
Pair	Wire	Color	Pair	Wire	Color	
1	T	Green	2	T	Black	0
1	R	Red	2	T	Black	24 <sup>3</sup>
1	T	Green	2	R	Yellow	24 <sup>3</sup>
1	R	Red	2	R	Yellow	0
1	T	Green	1	R	Red	24 <sup>3</sup>
2	T	Black	2	R	Yellow	24 <sup>3</sup>

**TABLE E  
(DIGITAL TELEPHONE CABLES)  
STATION CABLE CONTINUITY  
CHECK USING OHMMETER**

FROM			TO			Resistance
Pair	Wire	Color	Pair	Wire	Color	
1	T	Green	2	T	Black	open
1	R	Red	2	T	Black	open
1	T	Green	2	R	Yellow	open
1	R	Red	2	R	Yellow	open
1	T	Green	1	R	Red	40 ohms <sup>1</sup>
2	T	Black	2	R	Yellow	40 ohms <sup>1</sup>

**NOTES:**

1. This is the maximum allowable reading for all Digital and Electronic telephone cable runs except if connecting an HDSS console to Circuits 7 and 8 of a PEKU—then the maximum cable restriction is 20 ohms, not 40 ohms.
2. The green-red, black-yellow and white-blue measurements should be within 10% of each other.
3. Nominal voltage—within the limits of  $\pm 26.3$  ~  $\pm 27.8$  VDC while under AC power, polarity depending on voltmeter lead placements.



CHART NO. 1  
FAULT CLASSIFICATION

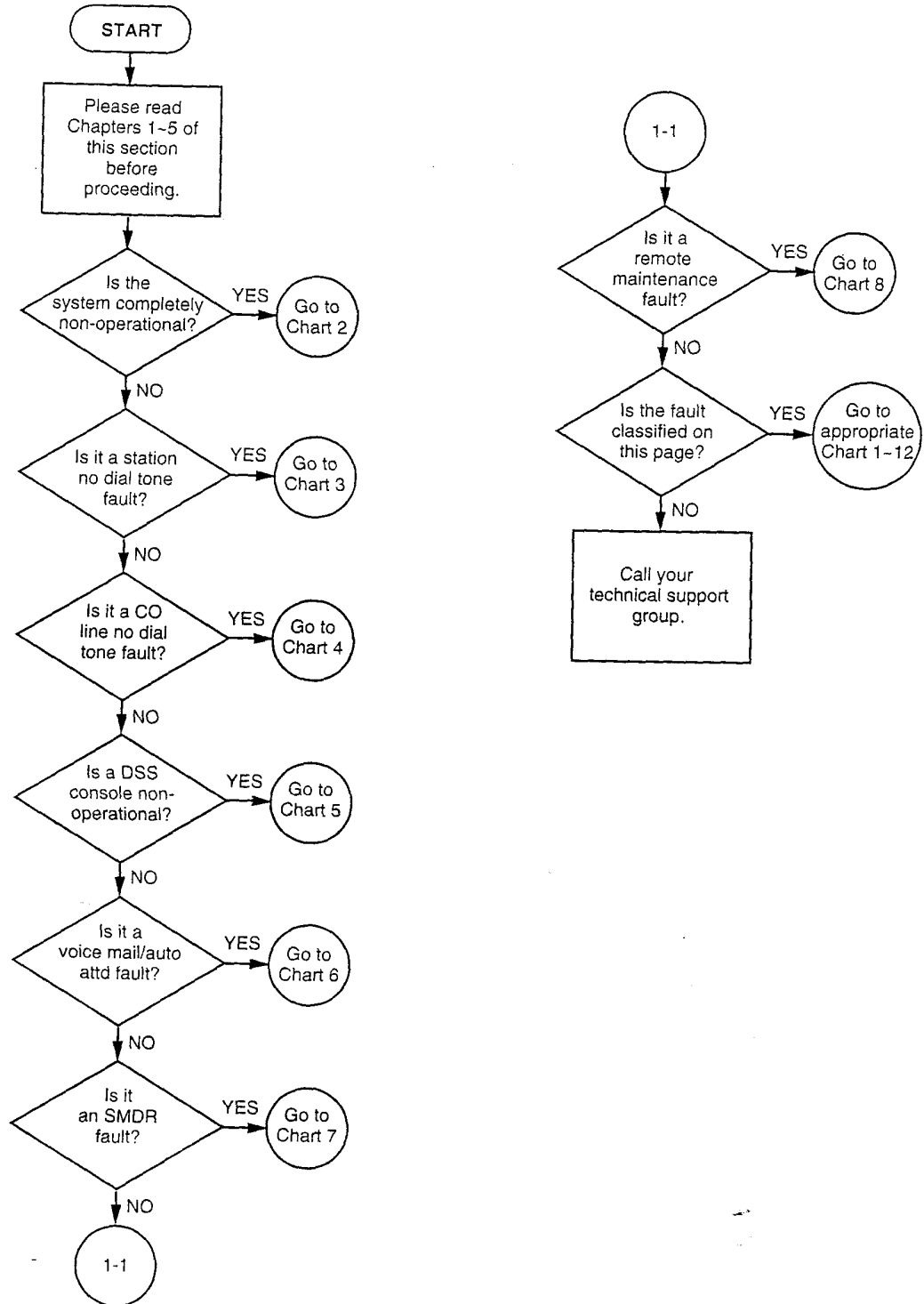
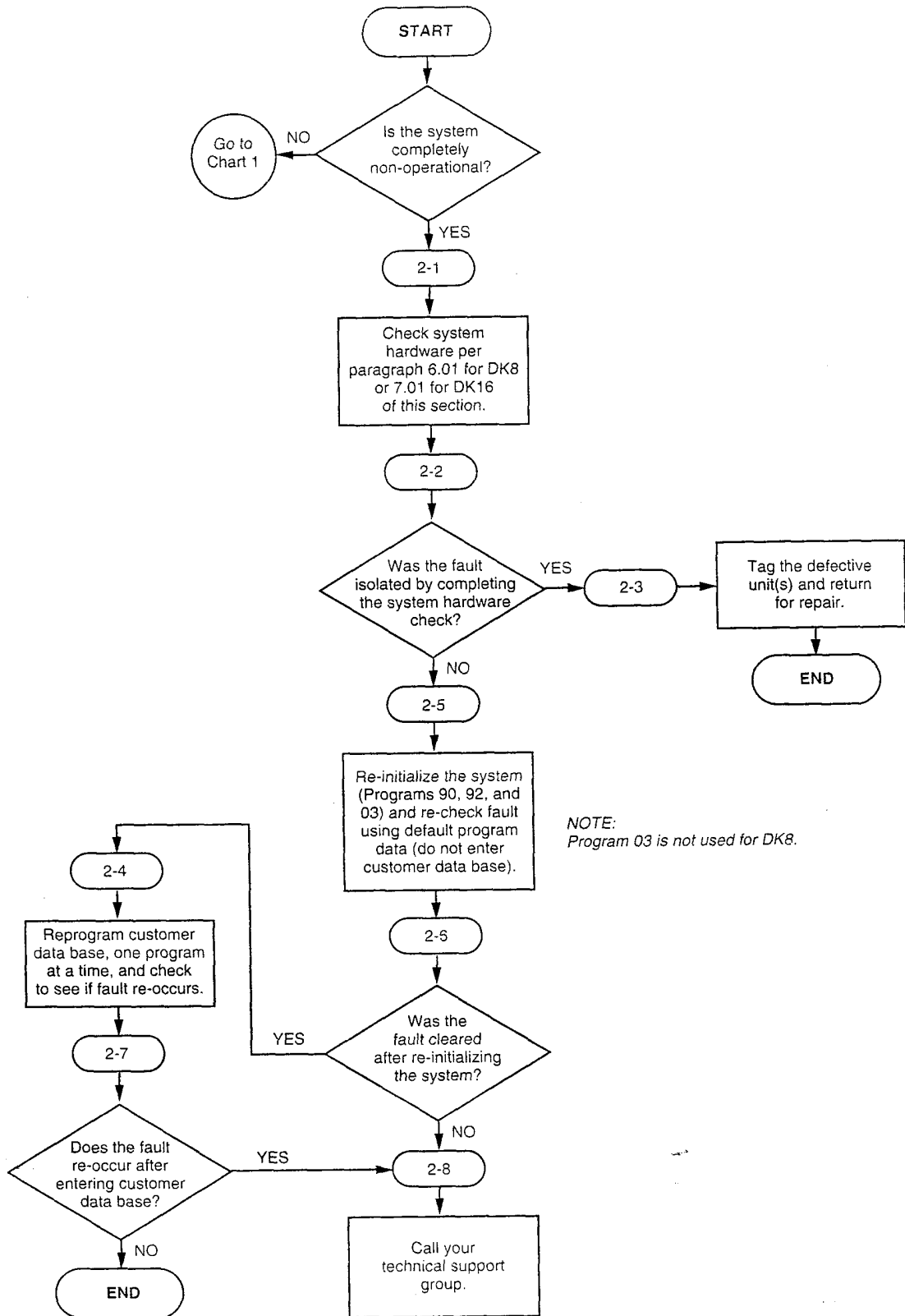
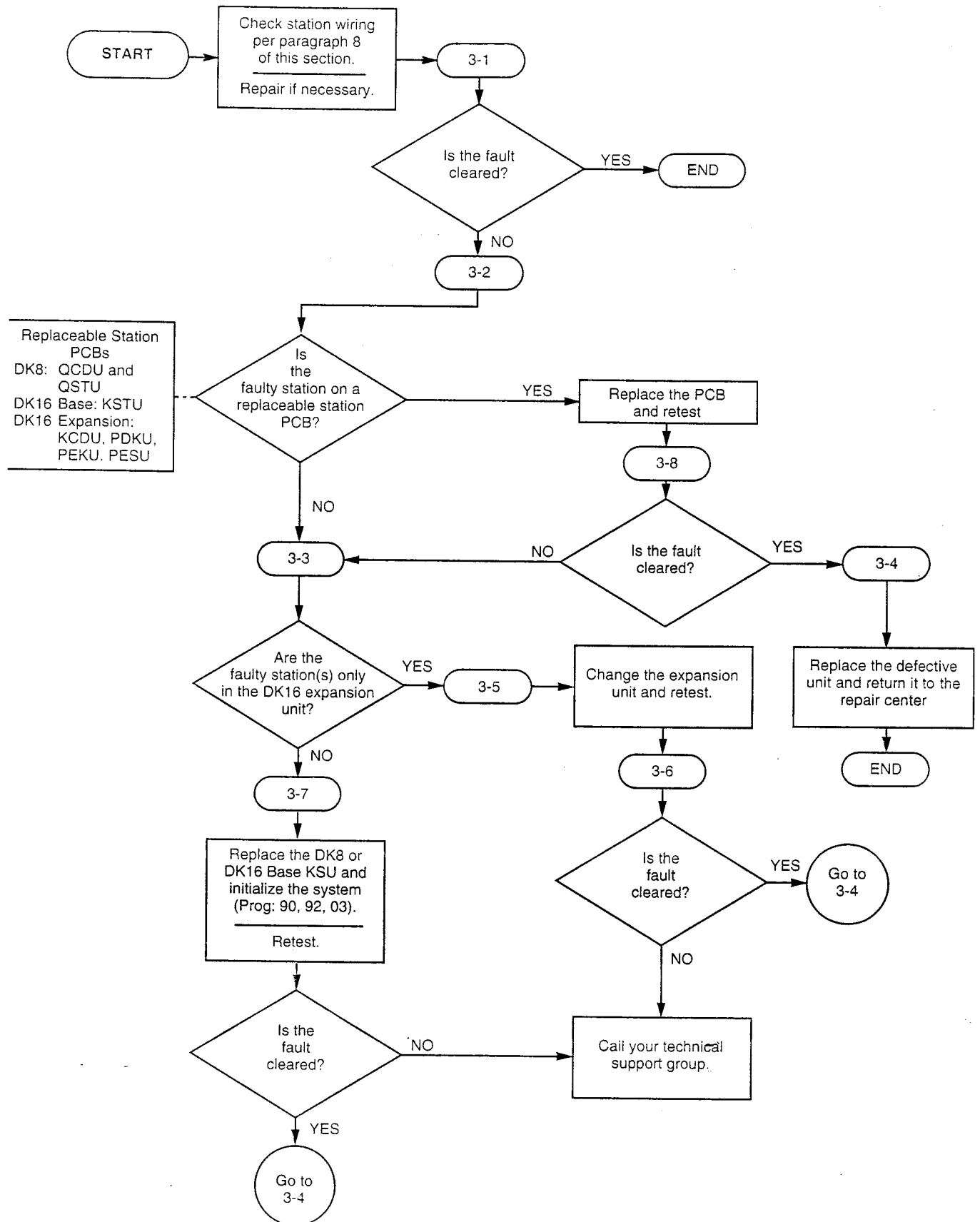


CHART NO. 2  
CATASTROPHIC FAULTS



NOTE:  
Program 03 is not used for DK8.

CHART NO. 3  
STATION DIAL TONE FAULTS



**CHART NO. 4**  
**CO LINE DIAL TONE FAULTS**

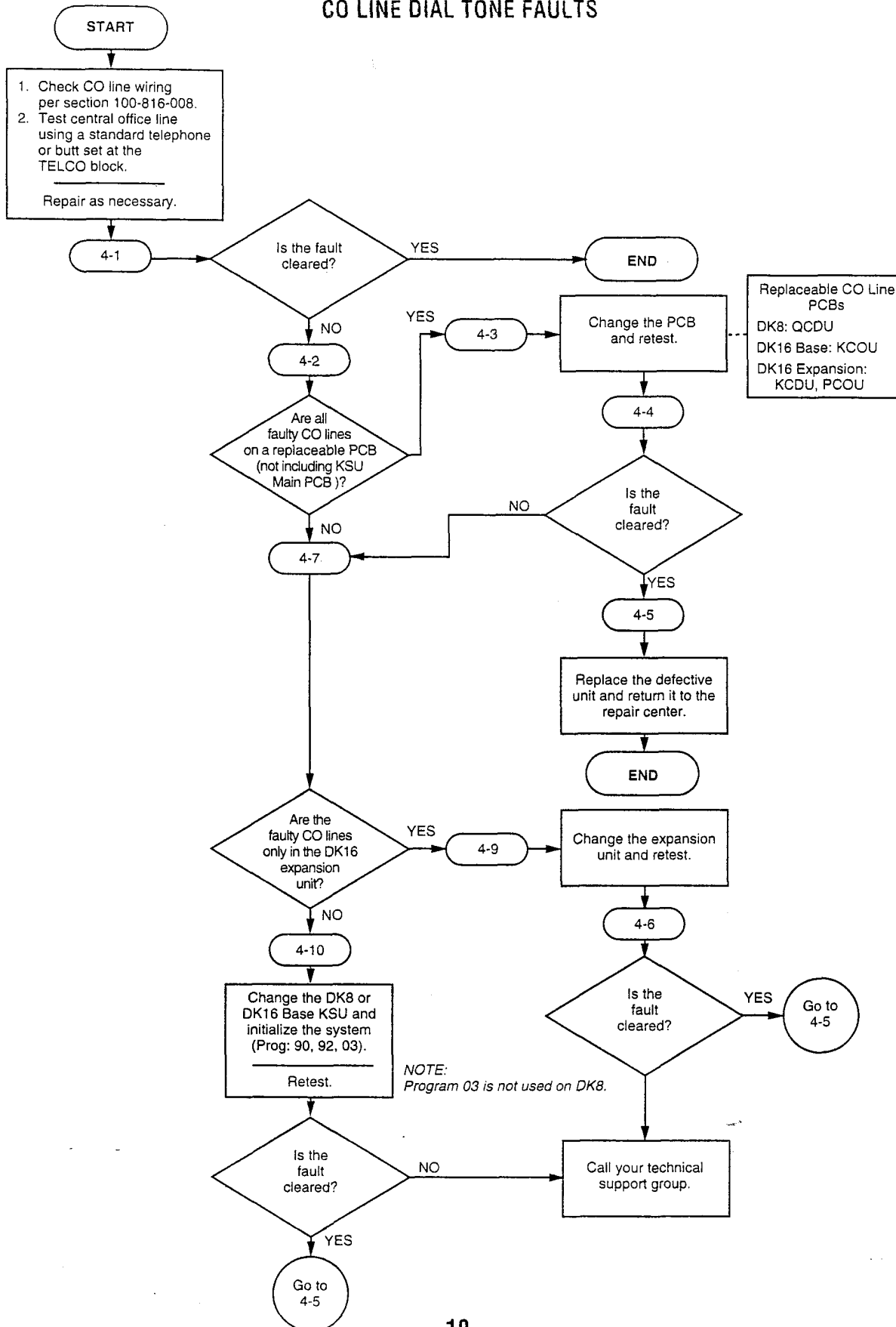
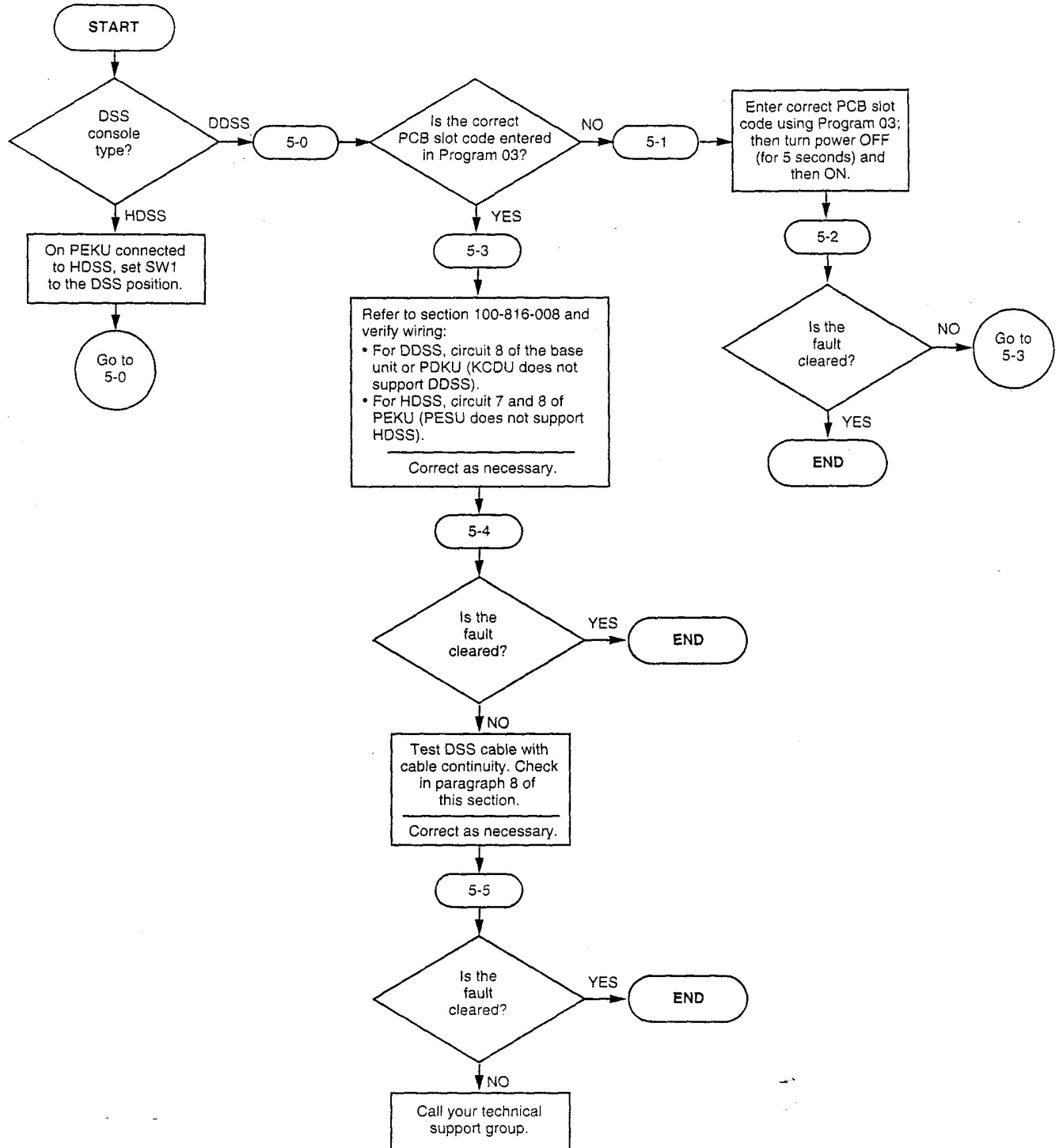


CHART NO.5  
DSS CONSOLE FAULTS (DK16 ONLY)



**CHART NO.6**  
**VOICE MAIL/(EXTERNAL) AUTO ATTENDANT (VM/AA) FAULTS**

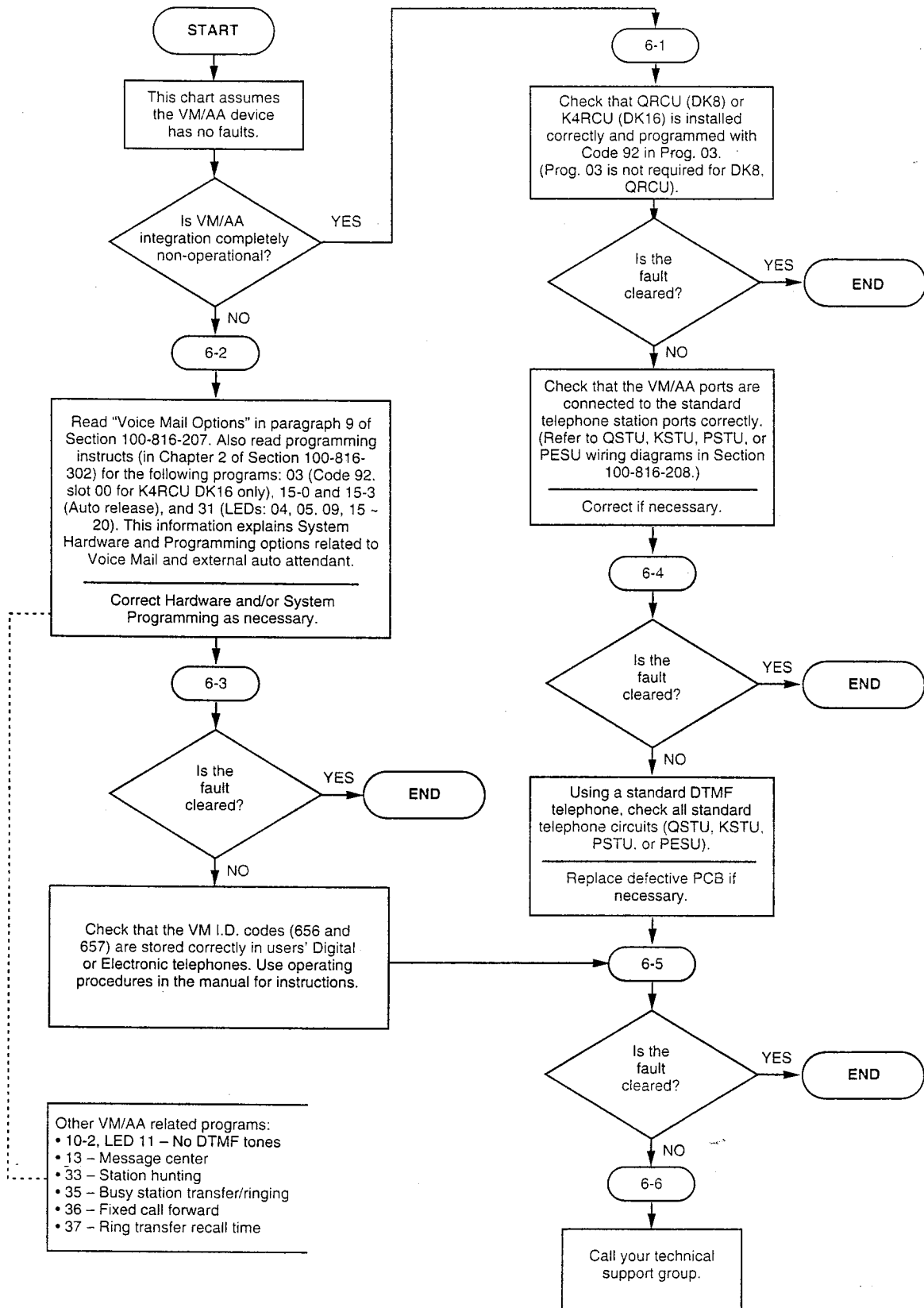


CHART NO.7  
STATION MESSAGE DETAIL RECORDING (SMDR) FAULTS

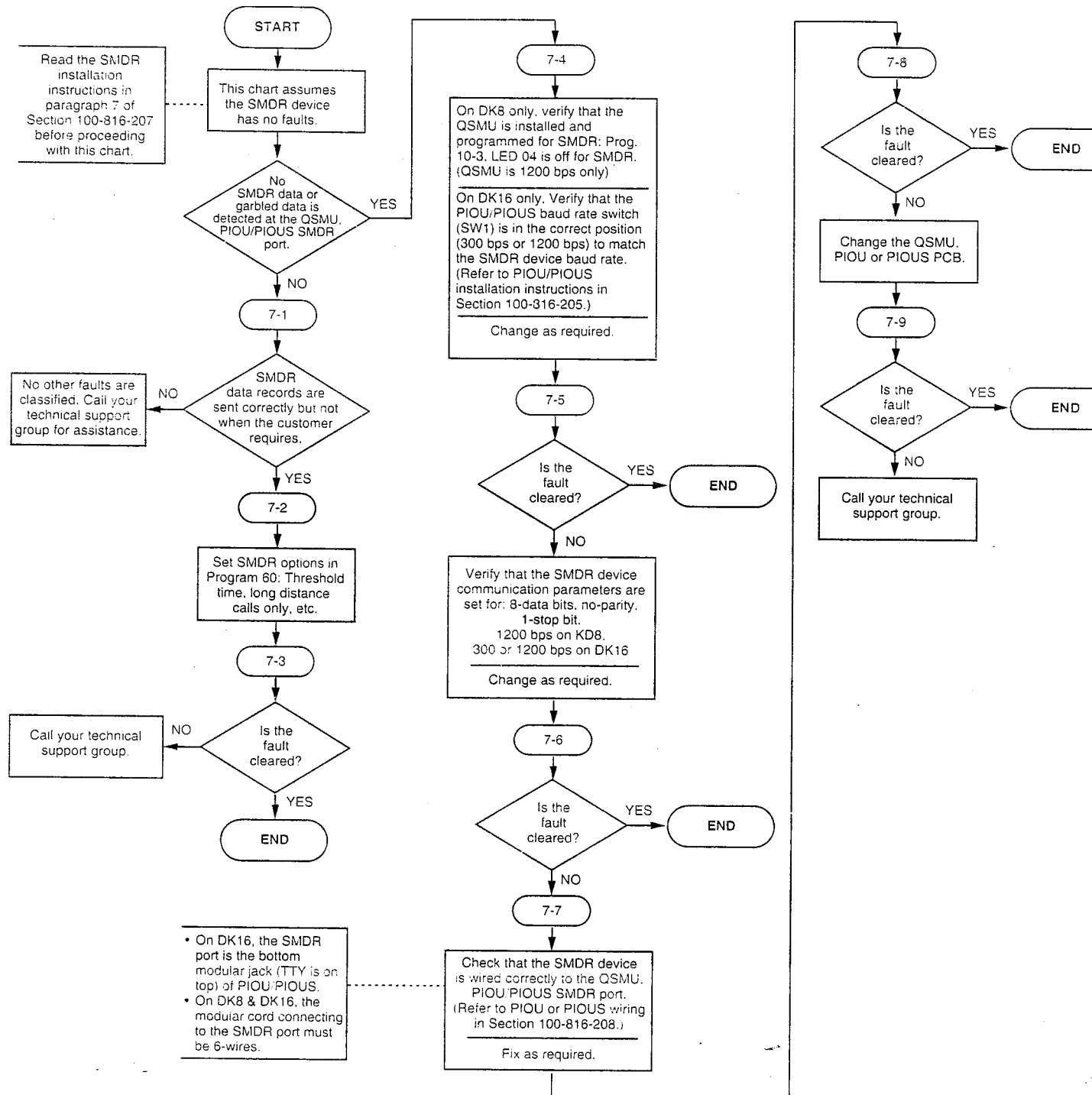
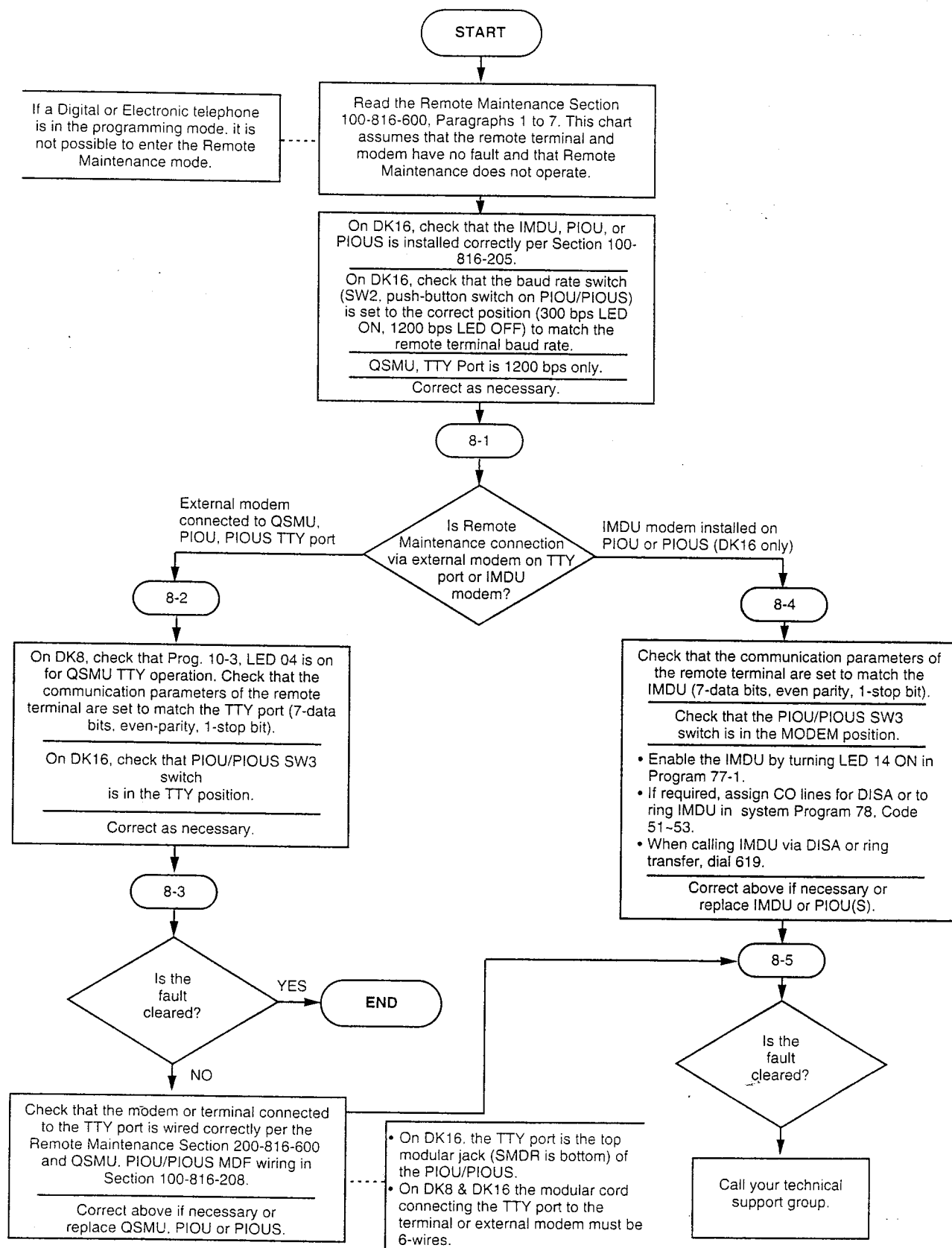


CHART NO.8  
REMOTE MAINTENANCE FAULTS





# ***Strata***<sup>®</sup> *DK8 & DK16*

## **REMOTE ADMINISTRATION AND MAINTENANCE PROCEDURES**

TABLE LIST

PARAGRAPH	SUBJECT	PAGE
1	USING REMOTE ADMINISTRATION AND MAINTENANCE .....	1
2	GENERAL DESCRIPTION .....	2
3	HARDWARE REQUIREMENTS .....	2
4	TERMINAL/MODEM INSTALLATION .....	5
4.10	Maintenance Terminal/External Modem Option System Hardware Requirements .....	6
4.20	DK8 and DK16 Local Maintenance Terminal Installation .....	6
4.30	Remote Maintenance Option Installation .....	6
4.40	Programming .....	7
4.50	DK16 IMDU On-site Testing .....	7
5	LOCAL TERMINAL OPERATION .....	8
5.00	Requirements .....	8
5.10	Set-up .....	8
5.20	Local Operation .....	8
6	REMOTE TERMINAL OPERATION .....	8
6.00	Requirements .....	9
6.10	Set-up .....	9
6.20	Remote Operation .....	9
6.30	Operation .....	10
7	MODE SELECTION .....	10
7.00	Selecting a Mode .....	10
8	PROGRAM MODE .....	10
8.00	General .....	10
8.10	System Record Sheets .....	10
8.20	Program Types .....	11
8.30	Multiple Station (Range) Programming .....	11
8.40	Programming Procedures .....	11
9	DATA DUMP MODE .....	11
9.00	General .....	11
10	TEST MODE .....	12
10.00	General .....	12
10.10	CO Line Testing .....	13
11	LCD MESSAGE MODE .....	13
11.00	General .....	13
11.10	Remote Called Station Message Mode .....	13
11.20	Remote Calling Station Message Mode .....	13
12	SPEED DIAL MODE .....	14
12.00	General .....	14
13	MODE EXIT .....	14
14	DISCONTINUE OPERATION .....	14
14.00	Local Terminal .....	14
14.10	Remote Terminal .....	14
15	EQUIPMENT COMPATIBILITY .....	14

TABLE LIST

TABLE	SUBJECT	PAGE
RM-A	PPTC MODIFIED WIRING FOR EXTERNAL MODEM TO TTY CONNECTION .....	4
RM-B	PPTC WIRING FOR LOCAL TERMINAL OR PERSONAL COMPUTER TO TTY CONNECTION .....	5
RM-C	PROGRAMMING PROMPTS .....	10
RM-D	PROGRAM 90: INITIALIZING PROGRAMS 00 ~ 97 .....	15
RM-E	PROGRAM 92: STATION SPEED DIAL, SPEED DIAL MEMO, VM ID CODES INITIALIZATION .....	16
RM-F	PROGRAM 92 (CONTINUED): SYSTEM SPEED DIAL, SPEED DIAL MEMO INITIALIZATION .....	17
RM-G	PROGRAM 92 (CONTINUED): LCD CHARACTER MESSAGE MEMORY INITIALIZATION .....	18
RM-H	PROGRAM 92 (CONTINUED): TIMED REMINDERS INITIALIZATION .....	19
RM-I	PROGRAM 92 (CONTINUED): DIGITAL TELEPHONE VOLUME LEVEL INITIALIZATION .....	20
RM-J	PROGRAM 92 (CONTINUED): CALL FORWARD BACKUP RAM INITIALIZATION .....	21
RM-K	PROGRAM 03: SLOT ASSIGNMENTS .....	22
RM-L	PROGRAM 00: SOFTWARE CHECK/REMOTE MAINTENANCE—SECURITY CODE .....	23
RM-M	PROGRAM 01: LOGICAL PORT DISPLAY .....	24
RM-N	PROGRAM 02: PHYSICAL PORT DISPLAY .....	24
RM-O	PROGRAM 04: PORT/STATION NUMBER ASSIGNMENT .....	25
RM-P	PROGRAM 05: FLEXIBLE ACCESS CODE NUMBERING .....	25
RM-Q	TYPE 1 PROGRAM PROCEDURE EXAMPLE (PROGRAMS: 10-1, 10-2, 10-3, 15, 16, 42-0, 77-1, 77-2) .....	26
RM-R	TYPE 2 PROGRAM PROCEDURE EXAMPLE (PROGRAMS: 20, 30, 31, 35, 40, 41, 43, 79, 81 ~ 89) .....	27
RM-S	PROGRAM 12: SYSTEM ASSIGNMENTS—BASIC TIMING .....	28
RM-T	PROGRAM 13: DEFINING THE MESSAGE CENTER .....	28
RM-U	PROGRAM 19: BACKGROUND MUSIC SLOT IDENTIFICATION .....	29
RM-V	PROGRAM 21: MODEM POOLING .....	29
RM-W	PROGRAM 22: DATA STATION HUNTING (DATA CALL ONLY) .....	30
RM-X	PROGRAM 28: DSS CONSOLE/ATTENDANT TELEPHONE ASSIGNMENTS .....	30
RM-Y	PROGRAM 29: DSS CONSOLE BUTTON ASSIGNMENTS .....	31
RM-Z	PROGRAM 32: AUTOMATIC PREFERENCE .....	32
RM-AA	PROGRAM 33: STATION HUNTING .....	32
RM-AB	PROGRAM 34: HOLD RECALL TIMING .....	33
RM-AC	PROGRAM 36: FIXED CALL FORWARD .....	33
RM-AD	PROGRAM 37: RING TRANSFER (CAMP-ON) RECALL TIME .....	34
RM-AE	PROGRAM 38: DIGITAL AND ELECTRONIC TELEPHONE BUTTONSTRIP TYPE .....	35
RM-AF	PROGRAM 39: FLEXIBLE BUTTON ASSIGNMENT .....	36
RM-AG	PROGRAM 42-1~8: PBX ACCESS CODE .....	37
RM-AH	PROGRAM 60: SMDR OUTPUT/ACCOUNT CODE DIGIT LENGTH .....	38
RM-AI	PROGRAM 69: VERIFIABLE ACCOUNT CODE ENTRY .....	39
RM-AJ	PROGRAM 70: VERIFY ACCOUNT CODE/TOLL RESTRICTION ASSIGNMENT .....	40

TABLE LIST (Continued)

TABLE	SUBJECT	PAGE
RM-AK	PROGRAM 78: CO LINE SPECIAL RINGING ASSIGNMENTS DISA/IMDU/NIGHT RINGING OVER EXTERNAL PAGE .....	41
RM-AL	PROGRAM 80: DIGITAL AND ELECTRONIC TELEPHONE RINGING TONES .....	42
RM-AM	PROGRAM 93: CO LINE IDENTIFICATION .....	43
RM-AN	PROGRAM 44 (A OR B): TOLL RESTRICTION TRAVELING CLASS OVERRIDE CODE ENTRY .....	44
RM-AO	PROGRAM 45-1: TOLL RESTRICTION DIAL PLAN .....	44
RM-AP	PROGRAM 45-2: TOLL RESTRICTION DISABLE .....	45
RM-AQ	PROGRAM 45-3 ~ 6: EQUAL ACCESS, SPECIAL COMMON CARRIER NUMBERS, AND AUTHORIZATION CODE DIGIT LENGTH .....	45
RM-AR	PROGRAM 45-8 ~ 9: TOLL RESTRICTION OVERRIDE CODE .....	46
RM-AS	PROGRAM 46-2 ~ 4: TOLL RESTRICTION ALLOWED/DENIED AREA CODES ASSIGNED BY CLASS .....	46
RM-AT	PROGRAM 46-6 ~ 8: TOLL RESTRICTION ALLOWED/DENIED OFFICE CODES ASSIGNED BY CLASS .....	47
RM-AU	PROGRAM 46-10 ~ 40: TOLL RESTRICTION CLASS PARAMETERS .....	48
RM-AV	PROGRAM 47: TOLL RESTRICTION EXCEPTION OFFICE CODES ASSIGNED BY AREA CODE .....	49
RM-AW	PROGRAM 48: STATION TOLL RESTRICTION CLASSIFICATION .....	50
RM-AX	PROGRAM 50-1: LCR PARAMETERS .....	50
RM-AY	PROGRAM 50-2: LCR HOME AREA CODE .....	51
RM-AZ	PROGRAM 50-31 ~ 35: LCR SPECIAL CODES .....	51
RM-BA	PROGRAM 50-4: LCR LDI PLAN NUMBER .....	52
RM-BB	PROGRAM 50-5: LCR LOCAL CALL PLAN NUMBER .....	52
RM-BC	PROGRAM 50-6: LCR DIAL ZERO TIMEOUT .....	53
RM-BD	PROGRAM 51: LCR AREA CODES .....	53
RM-BE	PROGRAM 52: LCR OFFICE CODE EXCEPTIONS FOR SPECIFIED AREA CODE .....	54
RM-BF	PROGRAM 53: LCR SCHEDULE ASSIGNMENT .....	55
RM-BG	PROGRAM 54: LCR ROUTE DEFINITION .....	56
RM-BH	PROGRAM 55-0: LCR MODIFIED DIGITS-DELETE .....	57
RM-BI	PROGRAM 55-1: LCR MODIFIED DIGITS-ADD .....	58
RM-BJ	PROGRAM 55-2: LCR MODIFIED DIGITS-END .....	59
RM-BK	PROGRAM 56: LCR STATION GROUP ASSIGNMENT .....	60
RM-BL	PROGRAM DATA DUMP .....	60
RM-BM	SPEED DIALING DATA DUMP .....	61
RM-BN	LCD MESSAGING DATA DUMP .....	61
RM-BO	MODE 95: REMOTE CALLING STATION MESSAGING (ADD/REVIEW/CHANGE) .....	62
RM-BP	MODE 97: REMOTE CALLING STATION MESSAGING (ADD/CHANGE) .....	63
RM-BQ	MODE 94: REMOTE CALLED STATION MESSAGING (ADD/REVIEW/CHANGE) .....	64
RM-BR	MODE 96: REMOTE CALLED STATION MESSAGING (ADD/CHANGE) .....	65
RM-BS	STATION/CO LINE STATUS CHECK .....	66
RM-BT	GENERAL STATION ACCESS AND BUTTON ACTIVATION .....	66
RM-BU	CO LINE TEST .....	67
RM-BV	SYSTEM DATE/DAY/TIME SETTING PROCEDURE .....	68
RM-BW	SPEED DIAL MODE (CHANGE/REVIEW) .....	69

FIGURE LIST

FIGURE	SUBJECT	PAGE
1	SECTION FLOWCHART .....	1
2	REMOTE MAINTENANCE EXTERNAL MODEM CONNECTION FOR DK8/16 (METHOD ONE OF ONE) .....	3
3	REMOTE MAINTENANCE EXTERNAL MODEM CONNECTION FOR DK8/16 (METHOD TWO OF TWO) .....	3
4	REMOTE MAINTENANCE USING IMDU MODEM (DK16 ONLY) .....	4
5	LOCAL MAINTENANCE USING ASCII TERMINAL OR PERSONAL COMPUTER .....	5
6	DATA DUMP PRINTOUT EXAMPLE .....	12
7	SAMPLE PRINTOUT OF SYSTEM MESSAGES .....	12
8	TEST MODE FUNCTION DIAGRAM .....	13

INDEX

	PAGE
INDEX .....	70

MESSAGE RECORD SHEET

	PAGE
MESSAGE RECORD SHEET .....	71

## 1 USING REMOTE ADMINISTRATION AND MAINTENANCE

1.01 Figure 1 is provided as a quick reference aid in using this section.

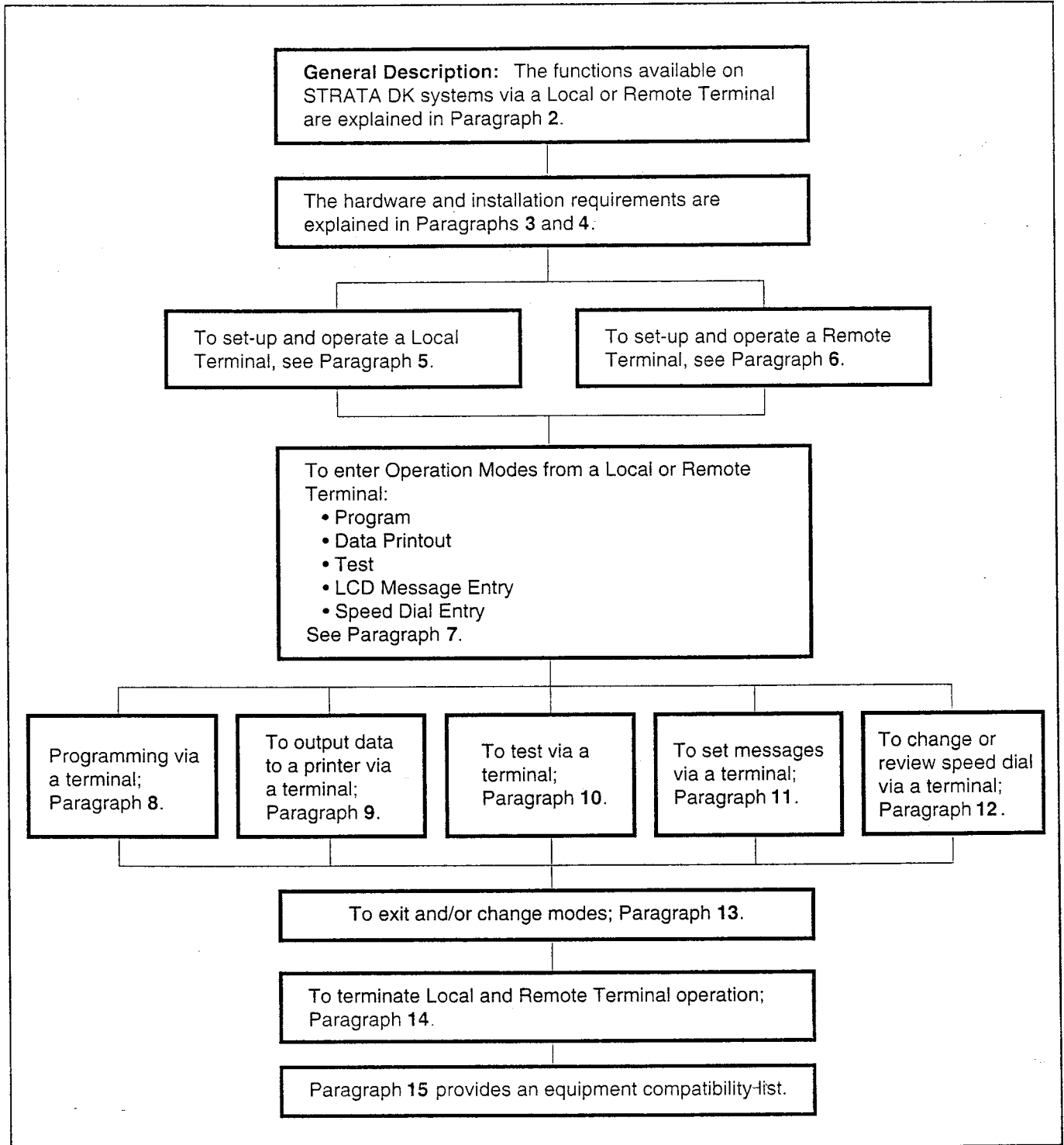


FIGURE 1  
SECTION FLOWCHART

## 2 GENERAL DESCRIPTION

**2.01** With the STRATA DK8, Remote Administration and Maintenance is accomplished with a remote terminal/modem communicating over the public telephone network, but only via an external modem connected to a dedicated CO line or standard telephone port. See Figures 2 and 3. With STRATA DK16 Remote Administration and Maintenance is accomplished with a remote terminal/modem communicating over the public telephone network via either an external modem (connected to a dedicated CO line or a standard telephone port); or, a modem unit (IMDU) installed on a PIOUS or PIOUS PCB in the Expansion Unit. See Figures 2, 3 and 4.

**2.02** Remote Administration and Maintenance calls with the STRATA DK16 may connect to the IMDU automatically via programmable CO line ringing assignments (**Program 81 ~ 89**) or Direct Inward System Access (DISA) CO lines (**Program 78**), or manually via the standard call transfer feature to intercom number 619. Automatic connection and DISA allow remote programming to be accomplished after business hours without on-site assistance. Remote Administration calls with the DK8 or the DK16 via an external modem connected directly to a CO line (instead of an IMDU) connect to the external modem automatically without any special station or CO line ringing assignments. When the external modem is connected to a standard telephone port, the call transfer feature, DISA, and ringing assignments can be utilized to access the Remote Administration.

**2.03** Remote Administration and Maintenance allows the following functions to be accomplished remotely:

**Program Mode:** Provides for complete programming of all STRATA DK8 or DK16 programs.

**Test Mode:** Provides for testing of STRATA DK8 or DK16 CO lines and stations.

**Data Dump Mode:** Provides a complete printout of all or individual STRATA DK8 or DK16 customer

data base programs, including Speed Dial numbers and LCD messages.

**Message Mode:** Provides for sending, adding, or changing digital and electronic telephone LCD messages.

**Speed Dial Mode:** Allows Station and System Speed Dial numbers to be programmed remotely.

*NOTE:*

*All the functions in the preceding paragraphs are also available via an on-site terminal connected directly to an optional PIOUS(S) PCB with DK16, or the optional QSMU PCB with DK8. These functions are also available to a terminal with a modem connected to a standard telephone port (Paragraph 5 and Figure 5).*

**2.04** There are two levels of Remote Administration and Maintenance.

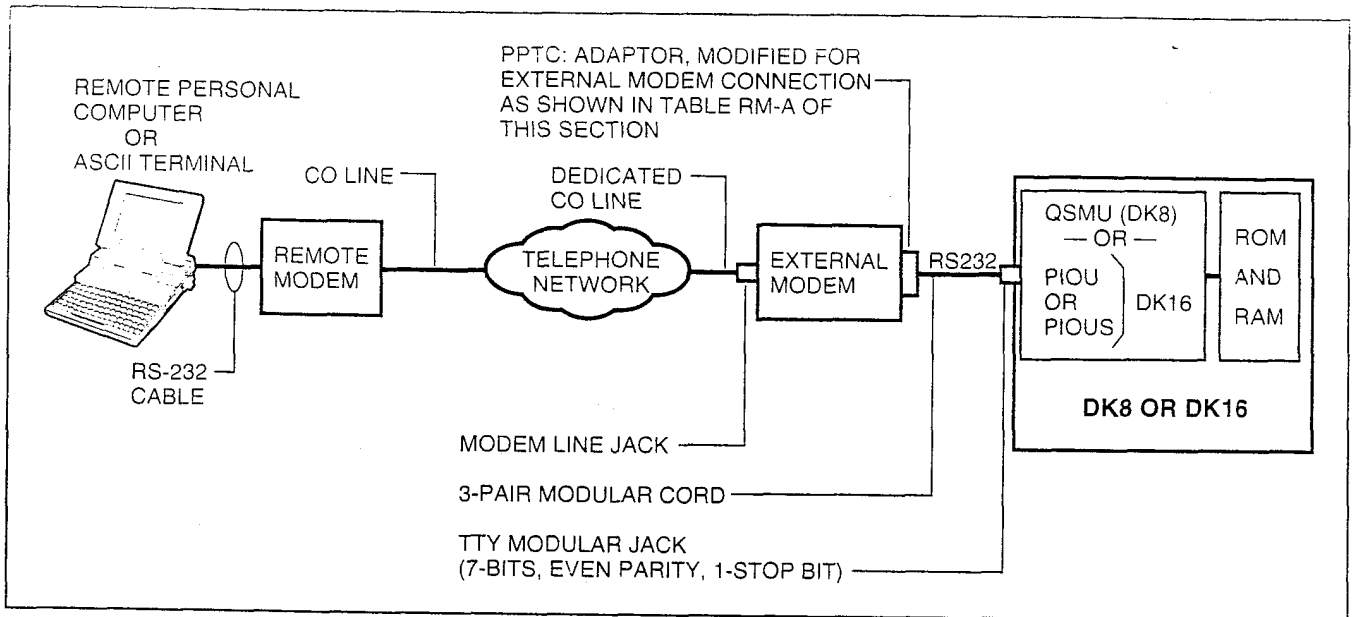
**Level 1:** Allows access to all programs.

**Level 2:** Allows access to **Programs 30 ~ 39** and **77 ~ 89**, which pertain only to individual station options such as button assignments, class of service, etc.

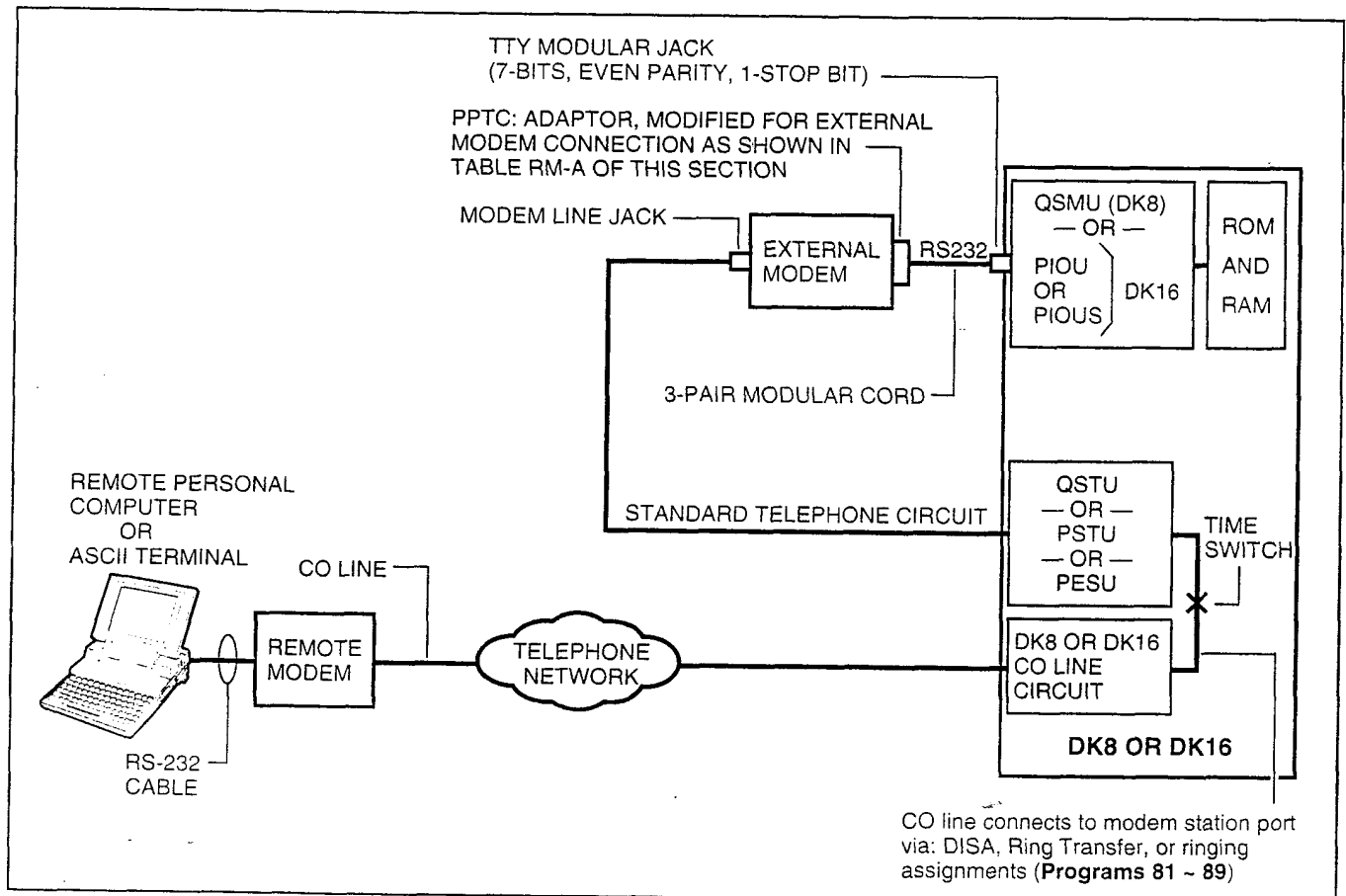
**2.05** Each Remote Administration and Maintenance level has a different programmable password for customer data base protection. This allows a customer to make certain station moves, adds, and changes in Level 2; while protecting the critical system assignments in Level 1 (refer to **Program 00**).

## 3 HARDWARE REQUIREMENTS

**3.01** For Remote Administration and Maintenance operation, the STRATA DK16 system must be configured with either an IMDU-equipped PIOUS(S) PCB in the optional Expansion Unit or an external modem connected to a PIOUS(S) and a dedicated CO line or standard telephone circuit. (See Figures 2, 3, and 4.) The STRATA DK8 must be configured with a QSMU PCB and an external modem connected to a dedicated CO line or standard telephone circuit. (See Figures 2 and 3.)



**FIGURE 2**  
**REMOTE MAINTENANCE EXTERNAL MODEM CONNECTION FOR DK8 & DK16 METHOD ONE**



**FIGURE 3**  
**REMOTE MAINTENANCE EXTERNAL MODEM CONNECTION FOR DK8 & DK16 METHOD TWO**



TABLE RM-A  
 PPTC MODIFIED WIRING FOR EXTERNAL MODEM TO TTY CONNECTION

PPCT (Modular to DB25) ADAPTOR, MODIFIED WIRING FOR CONNECTING TTY JACK TO AN EXTERNAL MODEM:

QSMU OR PIOUS/PIOUS, TTY JACK MODULAR PIN NO.	PPTC1A-5M ADAPTOR		MODEM RS-232 LEAD NAME
	MODULAR PIN NO.	DB25 PIN NO.	
→ 1 to RD	RD, 6 to	3*	RD
← 2 to TD	TD, 5 to	2*	TD
→ 3 to DSR	DSR, 4 to	6	DSR
← 4 to DTR	DTR, 3 to	20*	DTR
→ 5 to DCD	DCD, 2 to	8*	DCD
— 6 to SG	SG, 1 to	7	SG
4 Jumper to 5			RTS to CTS

**IMPORTANT:** \* PPTC1A-5M, pins 2 & 3 and pins 8 & 20 must be reversed in the field, as shown, for modem connection. Set Hayes modem to track status of carrier detect signal (AT & C1) and to answer (ATS0 = 1).

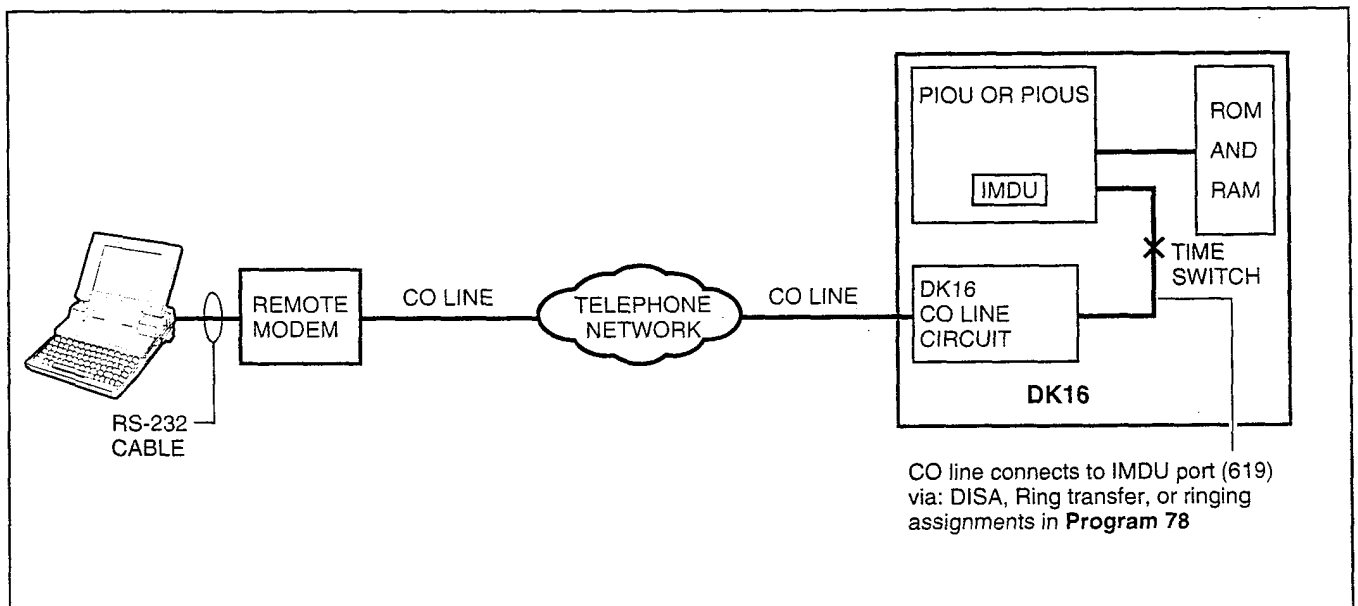
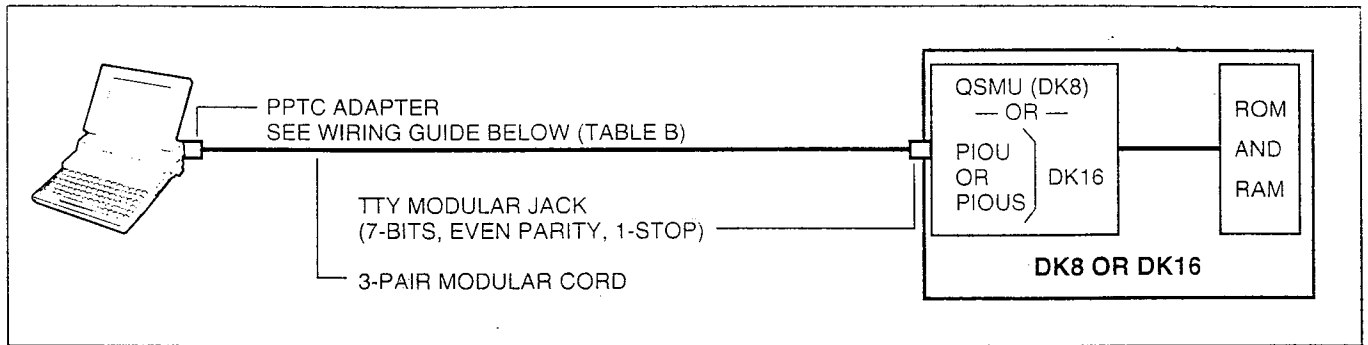


FIGURE 4  
 REMOTE MAINTENANCE USING IMDU MODEM (DK16 ONLY)



**FIGURE 5**  
**LOCAL MAINTENANCE USING ASCII TERMINAL OR PERSONAL COMPUTER**

**TABLE RM-B**  
**PPTC WIRING FOR LOCAL TERMINAL OR PERSONAL COMPUTER TO TTY CONNECTION**

PPTC (MODULAR TO DB25) ADAPTOR WIRING FOR CONNECTING TTY JACK TO A LOCAL TERMINAL OR PERSONAL COMPUTER SERIAL COMMUNICATIONS PORT.

QSMU OR PIOU/PIOUS, TTY JACK MODULAR PIN NO.	PPTC1A-5M ADAPTOR		DTE RS-232 LEAD NAME
	MODULAR PIN NO.	DB25 PIN NO.	
→ 1 to RD	RD 6 to —	3	RD
← 2 to TD	TD 5 to —	2	TD
→ 3 to DSR	DSR 4 to —	6	DSR
← 4 to DTR	DTR 3 to —	20	DTR
→ 5 to DCD	DCD 2 to —	8	DCD
— 6 to SG	SG 1 to —	7	SG
		4 Jumper to 5	RTS to CTS

## 4 TERMINAL/MODEM INSTALLATION

**4.01** DK8 and DK16 provide customers with a number of Remote Administration and Maintenance configuration options:

- A customer-supplied maintenance terminal can be connected to the system TTY port (DK8 QSMU, or DK16 PIOU or PIOUS) via an external modem either locally (Figure 5) or remotely (Figures 2 and 3).
- With the DK16, the IMDU modem (300 or 1200 baud full-duplex) can be connected to the DK16 PIOU or PIOUS to allow system programming and testing to be accomplished from a remote location (Figure 4).
- Instead of a modem or terminal, a Stand-alone Data Interface Unit (PDIU-DS) can be connected to the TTY port on the QSMU (DK8) or

PIOU/PIOUS (DK16) so that maintenance and programming can be administered internally or externally from desktop personal computers or terminals connected to Integrated Data Interface Units (PDIU-DIs).

### NOTES:

1. An external modem is required for Remote Maintenance if a QSMU is installed on DK8, or if an IMDU is not installed on DK16 PIOU or PIOUS. The IMDU has a built-in maintenance channel for remote connection; however, an external modem requires a CO line or standard telephone port (Figures 2 and 3).
2. The DK16 PIOU or PIOUS can only be installed in the Expansion Unit.

**REMOTE ADMINISTRATION AND MAINTENANCE PROCEDURES**  
**SECTION 100-816-600**  
**MARCH 1993**

**4.10 Maintenance Terminal/External Modem  
Option System Hardware Requirements**

**4.11** The STRATA DK8 must be equipped with a QSMU PCB and the DK16 with a PIOU or PIOUS PCB to support the maintenance terminal/external modem options. Connecting the maintenance terminal or external maintenance modem to the QSMU, PIOU, or PIOUS PCB is accomplished with a standard three-pair modular cord and a PPTC adaptor connected to the PCB TTY jack.

**4.20 DK8 and DK16 Local Maintenance  
Terminal Installation**

**4.21** Install the ASCII terminal in accordance with the following steps (Figure 5):

- 1) Connect the three-pair modular cable (24 AWG twisted pairs) and the PPTC adaptor from the DK8 QSMU or DK16 PIOU or PIOUS TTY port to the remote maintenance terminal DB25 connector.
- 2) For the DK8 QSMU, set **Program 10-3**, LED 04 ON for TTY operation.
- 3) For the DK16, set the PIOU or PIOUS SW2 switch to match the modem or terminal baud rate as follows:
  - Push in for 300 bps (baud rate indicator **CD4** is lit); let out (by pushing again) for 1200 bps (**CD4** is not lit).

**NOTE:**

*The DK8 QSMU baud rate is always 1200 bps.*

- 4) For DK16, set the PIOU or PIOUS **SW3** switch to the TTY position.

**NOTE:**

*The PIOU or PIOUS **SW3** switch is set to **MODEM** position for IMDU operation only.*

- 5) For DK16, set the **P13** jumper plug on the PIOU to the **BELL** configuration, or cut the **W4** jumper on the PIOUS (also for **BELL** configuration).

**NOTE:**

*The **P13** (PIOU) and **W4** (PIOUS) **CCITT** configurations are not normally used in the USA.*

- 6) For DK8 and DK16, set terminal communication parameters to seven bits, even parity, one-stop bit (300, or 1200 bps. See step 3 above).

**NOTE:**

*If a digital or electronic telephone is in the program mode, programming from the maintenance terminal is not allowed.*

**4.30 Remote Maintenance Option Installation**

**4.31 DK16 IMDU Maintenance Modem (Figure 4).** The IMDU mounts on the PIOU or PIOUS PCB and provides 300 or 1200 bps, full-duplex communication for remote maintenance (seven bits, even parity, one-stop bit). If the IMDU is employed, a dedicated CO line or standard telephone port is not required. Connection of the remote maintenance terminal is through existing system CO lines via intercom number 619. Refer to the PIOU or PIOUS portion of Section **200-816-205** for hardware installation and programming requirements.

**4.32 DK8 and DK16 External Maintenance Modem Installation.** Refer to Figure 2 or 3, as applicable, and install the external modem in accordance with the following steps:

**NOTE:**

*The Toshiba **PPTC RS-232** modular-to-DB25 adaptor is factory configured for ASCII terminal connection. Pins 2 and 3 and Pins 8 and 20 of the adaptor must be reversed for external modem connection (see Table RM-A).*

- 1) Connect the modular cord from the DK8 QSMU or DK16 PIOU or PIOUS TTY port to the PPTC adaptor and then to the external maintenance modem RS-232 25-pin connector.
- 2) Connect the external maintenance modem line-side to a dedicated CO line (tip and ring) or to a dedicated standard telephone port, tip and ring (QSTU with DK8; KSTU, PSTU, or PESU with DK16). Refer to Wiring Diagrams, **Section 200-816-208**, for wiring/interconnecting details.
- 3) For DK16, set the PIOU or PIOUS **SW2** switch to match the modem or terminal baud rate:
  - Push in for 300 bps (baud rate indicator

CD4 is lit), let out (by pushing again) for 1200 bps (CD4 is not lit).

**NOTE:**

*The DK8 QSMU baud rate is always 1200 bps.*

- 4) For DK16, set the P10U or P10US **SW3** switch to the TTY position.

**NOTE:**

*The P10U or P10US **SW3** switch is set to the **MODEM** position for IMDU operation only.*

- 5) For DK16, set the **P13** jumper plug on the P10U to the **BELL** configuration, or cut the **W4** jumper on the P10US (also for **BELL** configuration).

**NOTE:**

*The **P13** (P10U) and **W4** (P10US) **CCITT** configurations are not normally used in the USA.*

- 6) The communication parameters for the terminal that will be used to communicate through the external modem connected to the TTY port should be set to seven-bits, even parity, one-stop bit. (300 or 1200 bps, see step 3 above).
- 7) Programming and system testing, via the external maintenance modem, is described later in this section. Access to the external maintenance modem is accomplished as follows:
  - If the modem is connected to a dedicated CO line, call the CO line number to establish modem communication.
  - If the modem is connected to a standard telephone port, call a STRATA DK CO line that can be transferred to (or programmed to ring) the standard telephone modem port to establish modem communication. It is also possible to establish communications by calling in on a STRATA DK DISA CO line and dialing the intercom number of the modem connected to the standard telephone port.

#### 4.40 Programming

**4.41** If an IMDU is used on DK16, enable the IMDU in **Program 77-1** (LED 14). If using an external

modem with STRATA DK16 or DK8, skip LED 14 in **Program 77-1**.

**4.42** For DK8 only, turn LED 04 "**ON**" in **Program 10-3** to activate the QSMU for external modem operation.

**4.43** For DK16 only, if Remote Administration and Maintenance calls are to connect to the IMDU automatically, assign the designated CO lines to ring the IMDU intercom number (619) in **Program 78** as required (use standard STRATA DK16 programming procedures).

**4.44** For all cases of Remote/Local Maintenance with a PC or ASCII terminal for either STRATA DK8 or STRATA DK16 program the security codes for Levels 1 and 2 as in the Programming Procedures, Section **200-816-300**. Reference **Program 00**.

**NOTE:**

*The security codes are initialized as "0000". These codes may also be changed via a local or remote terminal.*

#### 4.50 DK16 IMDU On-site Testing

**4.51** From any working station, test the functioning of the IMDU for DK16.

- 1) Press the **Intercom** button.
  - Receive intercom dial tone.
- 2) Dial **6 1 9**.
  - Receive modem tone from the IMDU after a two-second delay.
- 3) Press the **Speaker** button to release.
- 4) Make an incoming call over each CO line that is programmed to ring the IMDU (station 619).
  - Receive-modem tone from the IMDU after a two-second delay with each call.

**NOTE:**

*This test checks basic programming and IMDU operation, and should be completed before*

**REMOTE ADMINISTRATION AND MAINTENANCE PROCEDURES**  
**SECTION 100-816-600**  
**MARCH 1993**

*continuing with Remote Administration and Maintenance installation.*

- 5) If a terminal is to be utilized on-site, refer to Paragraph 5. For off-site programming refer to Paragraph 6.

## **5 LOCAL TERMINAL OPERATION**

### **5.00 Requirements**

**5.01** For DK16, the optional Expansion Unit must have a PIOU or PIOUS PCB installed to perform on-site Remote Administration from a local terminal. For DK8, a QSMU PCB is required. Paragraph 4 and **Figure 5** provide installation details on local terminal installation.

**5.02** The local terminal for either the STRATA DK16 or the DK8 must have an EIA RS-232 interface, communicate in ASCII code at 300 or 1200 bps (1200 bps only for DK8), have a standard typewriter-type keyboard, and display data via a CRT display or printer. A personal computer (PC) capable of emulating the described terminal with a communications software package (such as PROCOMM) may also be used (Figure 5).

**5.03** Operating the PC or terminals, local or remote, is identical. The only difference is the physical connection and the method used to establish initial communications.

### **5.10 Set-up**

**5.11** Refer to Figure 2 and verify that the local terminal is connected and set-up as follows:

- 1) Connect the RS-232 cable to the terminal connector and the PIOU(S) or QSMU TTY connector.

**NOTE:**

*If a personal computer is being used, connect the cable to the serial "COM" port.*

- 2) Set the PC or terminal baud rate to match the DK16 SW2 PIOU(S) setting (300 or 1200 bps) or the DK8 QSMU setting (1200 bps).
- 3) Set the terminal for "Full Duplex" operation.

- 4) Set the keyboard for "Caps Lock" on.
- 5) Set the parameters of the terminal (or modem) connected to the TTY to:  
Word length: Seven bits  
Stop bits: One  
Parity: Even

### **5.20 Local Operation**

**5.21** Use the procedure below to establish communications between the local terminal and the PIOU(S) or the QSMU so that programming may be accomplished via the terminal.

**NOTE:**

*Hereafter, whenever the term **CR** is used, it means the return or enter key, depending on the keyboard being used. **SPACE** means the space bar. An empty square indicates one of several characters will appear in that location (either on the terminal screen or in a printout).*

- 1) Set-up the terminal as described in Paragraph 5.10.
- 2) Set the terminal to on-line.
- 3) Set "Caps Lock" on (upper case).
- 4) Press **CR** key.
  - The system responds, and the terminal displays:  
DK CONNECT  
> CODE
- 5) Type the four-digit security code, and press **CR**. (Default code = 0000.)
  - The system responds, and the terminal displays:  
OK  
MODE

**NOTE:**

*The security code can be entered any time the CODE prompt appears.*

- 6) To continue, go to Paragraph 7.

## **6 REMOTE TERMINAL OPERATION**

### **6.00 Requirements**

**6.01 Terminal:** For the STRATA DK8 or the STRATA DK16, the terminal must interface with an

asynchronous modem, communicate in ASCII code at 300 or 1200 bps (1200 only for DK8), have a standard typewriter-type keyboard, and display data via a CRT display or printer. A personal computer capable of emulating the described terminal with a communications software package (such as PROCOMM) may also be used. (See Paragraph 15 for compatible personal computers).

**6.02 Modem:** For either system, the modem must be full-duplex asynchronous, operate at 300 or 1200 bps (1200 only for DK8) and have an RS-232 interface to connect with a terminal or PC (as described in Paragraph 6.01). It must interface with the public telephone network and be compatible with Bell 103 or 212 modem specifications.

### 6.10 Set-up

**6.11** Refer to Figures 2, 3, and 4, and verify that the remote terminal is connected and set-up as follows:

- 1) Connect the terminal and modem together with the RS-232 cable.

**NOTE:**

*If a personal computer is being used, connect the cable to the serial "COM" port.*

- 2) Connect the modem line input to a CO/PBX line for access to the public telephone network.
- 3) Set the terminal and modem baud rate to match the DK16 PIOU(S) setting (300 or 1200 bps) or DK8 QSMU setting (1200 bps).
- 4) Set the terminal and modem for "Full Duplex" operation.
- 5) Set the terminal parameters to:  
Word length: Seven bits  
Stop bits: One  
Parity: Even

### 6.20 Remote Operation

**6.21** Automatic connection via ringing assignments:  
To establish communication between the remote

terminal and the IMDU or an external modem connected to a dedicated CO line, call the number of the system CO line assigned to ring the IMDU or the external modem via the remote terminal/modem set-up:

- 1) Observe the following:
  - When the CO line rings-in, it will connect to the IMDU or the external modem and the IMDU or external modem will respond by returning modem answer tone to the remote modem.
  - The remote modem will return modem tone to the IMDU or external modem and communication will be established.
  - When communication is established, the terminal will display: CONNECTED or COMMUNICATIONS (see Note in Paragraph 6.22).
- 2) To continue, Press **CR** and enter the security code per Paragraph 6.30.

### 6.22 Manual connection via call transfer:

- 1) Using a telephone (at the remote location) that can switch to the terminal/modem, dial the number of a system CO line.
- 2) When the call is answered, request that it be transferred to station 619 if an IMDU is being used. For applications where an external modem is connected to a dedicated standard telephone port, ask to be transferred to the intercom number assigned to the modem.
- 3) After the call is transferred and you hear modem tone from the IMDU or external modem, switch the call from the telephone to the terminal/modem.
- 4) Observe the following:
  - When the CO line is transferred, it will connect to the IMDU or external modem.
  - The IMDU or the external modem and the remote modem will respond to each other with modem tone and communication is established.

**REMOTE ADMINISTRATION AND MAINTENANCE PROCEDURES**  
**SECTION 100-816-600**  
**MARCH 1993**

*included above. use Program Mode procedures.*

**9.04 Speed Dialing Dump:** While in the dump mode (see Paragraph 7), enter "REP" and two or three characters and press **CR**. The characters represent the speed dialing codes for either an individual station, **A L L** (all stations and system data) **S Y S** (system data only).

**9.05 LCD Messages Dump:** While in the dump mode (see Paragraph 7), enter "MSG" and two or three characters and press **CR**. The characters represent stored messages for either an individual station, **A L L** (all stations and system data) or **S Y S** (system data only). For a printout example, see Figure 7.

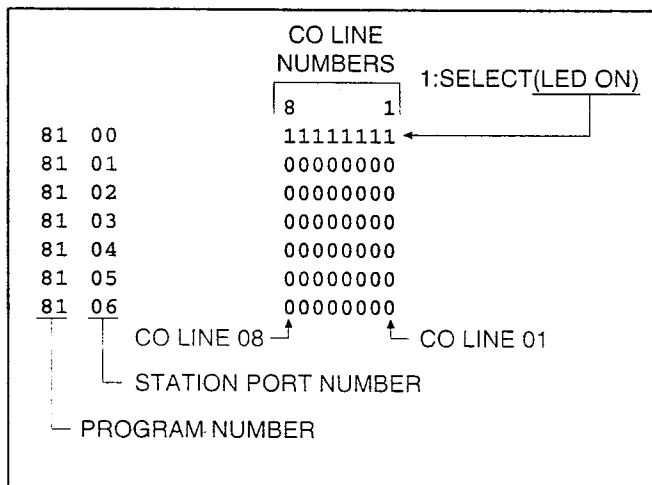
**9.06** Tables provide a quick reference to the step-by-step procedures to output the appropriate data.

**10 TEST MODE**

**10.00 General**

**10.01** The remote test mode (see paragraph 7) can be used to test STRATA DK8 or DK16 stations and CO line circuits from an off-site location.

**10.02** This testing function is accomplished by accessing stations from the remote terminal, and activating various buttons on digital and electronic telephones to make telephone calls, set function buttons, change the system time and date, etc. (see Figure 8 and Tables RM-BS ~ BV).



**FIGURE 6**  
**DATA DUMP PRINTOUT EXAMPLE**

**IMPORTANT!**

*Any digital or electronic telephone button can be activated from the remote terminal at any time while in the Test Mode (even while the end user is using the telephone). Therefore, caution must be used to prevent service interruption or interference. The Test Mode provides status tests to check whether or not a station or CO line is in use. The status checks should always be made before performing other tests (see Table RM-BS).*

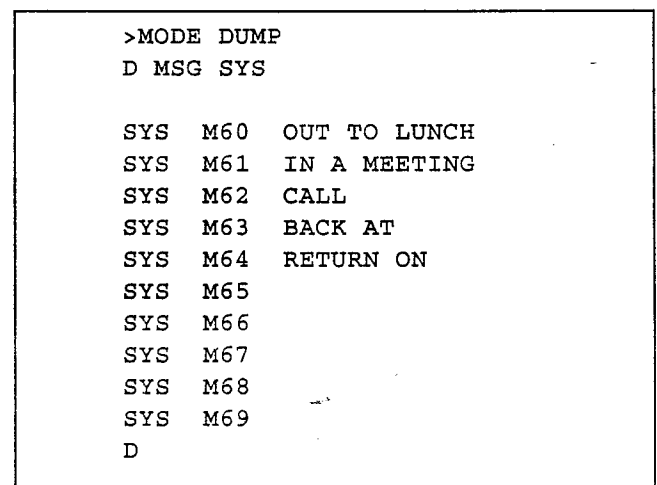
**10.10 CO Line Testing**

**10.11** To test CO line transmission, two or three CO lines must be available at the remote site (see Figure 8 and Table RM-BU).

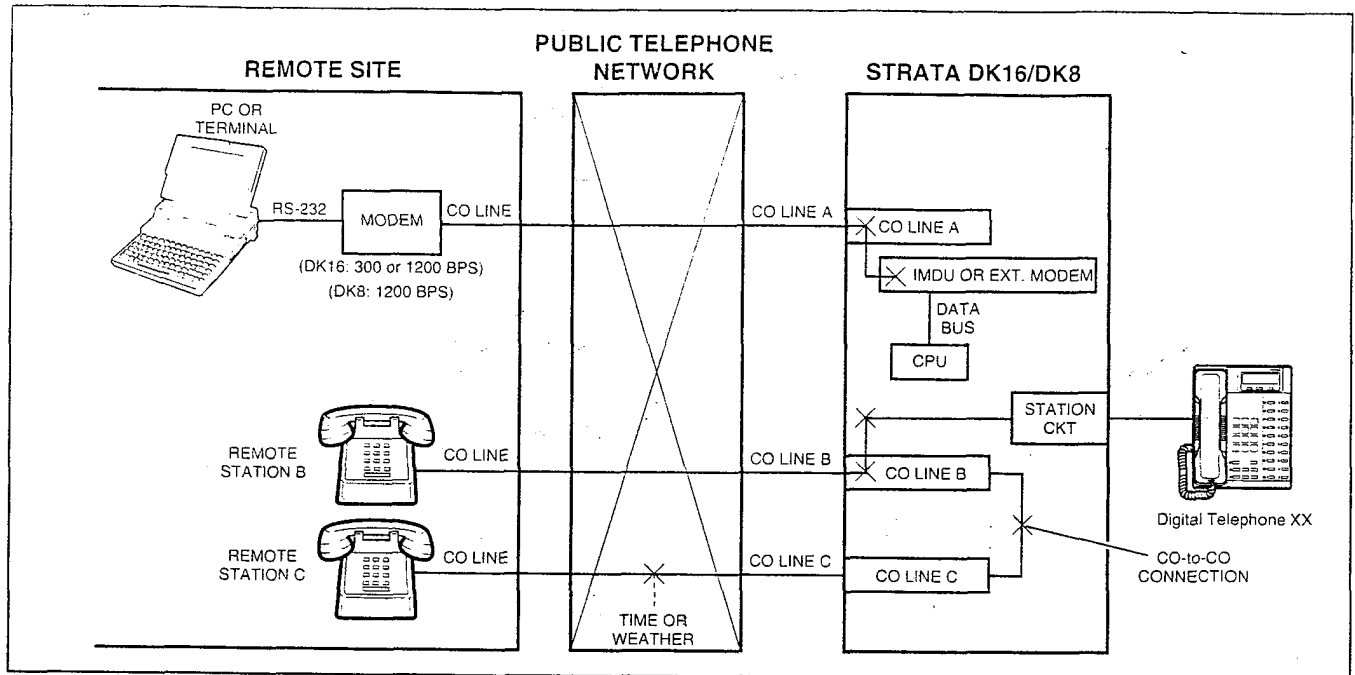
**10.12** CO line testing is accomplished by using all of the following two methods:

- 1) Establish a talk path between the two remote stations (B & C) via a CO-to-CO connection through STRATA DK8 or DK16.
- 2) Establish a talk path between a remote station and the time or weather service via a CO-to-CO connection through STRATA DK8 or DK16.

**10.13** The procedures in the tables provide examples of the types of tests and functions that can be accomplished with the Test Mode. These proce-



**FIGURE 7**  
**SAMPLE PRINTOUT OF SYSTEM MESSAGES**



**FIGURE 8**  
**TEST MODE FUNCTION DIAGRAM**

dures do not cover all the possible tests that can be performed remotely; however, by using the principles given, other tests are possible.

## 11 LCD MESSAGE MODE

### 11.00 General

**11.01** This mode allows a local or remote terminal to set Called and Calling Station LCD messages for station users (see Table RM-BO ~ BR). The messages may be system or station type and are stored in their respective memory locations when set.

### 11.10 Remote Called Station Message Mode

**11.11** Allows the terminal to set a Called Station Message for an originating station with the destination of the message being a station or group of stations.

**11.12** When the message is set, the Msg LED(s) on the destination station(s) flash.

**11.13** When a destination station calls the originating station, the message is displayed on the destination station's LCD.

**Mode 94:** To edit and/or review a Called Station Message before setting it, use this mode. It will print out the existing message and allow additions to it (such as a time or a date) before it is set. (The message cannot be changed with this mode—just added to.)

**Mode 96:** To add or change a Called Station Message before setting it, use this mode. It does not display the existing message, but allows a completely new message to be entered before it is set.

### 11.20 Remote Calling Station Message Mode

**11.21** Allows the terminal to set a Calling Station Message for a station. The message will be set on the station's LCD and is automatically displayed on other stations' LCDs whenever they call that station.

**Mode 95:** To edit and/or review a Calling Station Message before setting it, use this mode. It will display the existing message and allow additions



**REMOTE ADMINISTRATION AND MAINTENANCE PROCEDURES**  
**SECTION 100-816-600**  
**MARCH 1993**

to it (such as a time or a date) before it is set. (The message cannot be changed with this mode—just added to.)

**Mode 97:** To add or change a Calling Station Message before setting it, use this mode. It does not display the existing message, but allows a completely new message to be entered before it is set.

**11.22** Use the procedures in the tables to set messages via Modes 94/96 and 95/97.

## **12 SPEED DIAL MODE**

### **12.00 General**

**12.01** The Speed Dial Mode (see Table RM-BW) can be used to add or change speed dial numbers to any of the System Speed Dial memory locations (60 ~ 99) and Station Speed Dial memory locations (10 ~ 49).

**12.02** Chain Speed Dial numbers can also be programmed using the Speed Dial Mode. See the Digital or Electronic Telephone User Guide for more information regarding chain Speed Dialing.

**12.03** To program Speed Dial numbers, enter the REPT mode per Paragraph 7 of this section. Then use the Speed Dial Mode Procedure at the end of this section.

## **13 MODE EXIT**

**13.01** Exit the current mode per Paragraph 13.02 and select the desired mode via Paragraph 7.

**13.02** To exit the Program (PROG), Data Dump (DUMP), Test (TEST) or Speed Dial (REPT) mode:

- At the P, D, T or R prompt, enter QUITCR and observe:  
>MODE

**13.03** To exit the LCD Message (MESG) mode:

- At anytime while in the message mode, enter: m 0 q and observe:  
>MODE

### *NOTE:*

*To exit the Message Mode, the terminal keyboard must be in lower case.*

## **14 DISCONTINUE OPERATION**

### **14.00 Local Terminal**

**14.01** Exit current operating mode via Paragraph 13 and observe that the MODE prompt is displayed on the terminal.

### **14.10 Remote Terminal**

**14.11** Exit current operating mode via Paragraph 13 and observe that the MODE prompt is displayed on the terminal.

**14.12** To discontinue remote operation:

- 1) Take the terminal off-line.
- 2) Verify that the modem drops the line.

## **15 EQUIPMENT COMPATIBILITY**

**15.01** Equipment that is known to be compatible with STRATA DK8 and DK16 Remote Administration and Maintenance is listed as follows. This list does not show all of the equipment that will work, only the equipment that has been proven compatible in the field or lab.

### **Terminals**

- Texas Instruments: Silent 700
- Panasonic: KXD-4920
- Personal Computers with the PROCOMM communications software package.

### **Modems**

- Hayes compatible

TABLE RM-D  
PROGRAM 90  
INITIALIZING PROGRAMS 00 ~ 97

STEP	ACTION	DISPLAY/PRINTOUT
1	Enter the Program Mode At the >MODE prompt enter <b>P R O G CR.</b>	>MODE PROG
2	Enter Program Number 90 Press <b>CR.</b>	P 90 P90
3	To Initialize All Programs Enter <b>0 0 * 9 7</b> <i>NOTE: Single programs can be initialized by entering a single program number plus #. Group numbers are separated by an *.</i>	P90 00*97
4	Enter button/LED number <b>0 1.</b>	P90 00*97 01 N
5	Change 01 button/LED to "ON" by entering <b>Y.</b>	P90 00*97 01 N Y
6	Press <b>SPACE.</b>	P90 00*97 01 N Y 02 N
7	Change LED 02 to "ON" by entering <b>Y.</b>	P90 00*97 01 N Y 02 N Y
8	Press <b>CR.</b> Initialization complete. <i>NOTE: If program data is not entered correctly, then CR will not respond. To retry, press DELETE CR.</i>	P90 00*97 01 N 02 N Y P90
9	Exit Program 90 Press # # <b>CR.</b>	P90 # P
10	For DK16, Enter Program 77 Press <b>7 7 CR.</b>	P77
11	Press <b>1 1 4.</b> then: <b>Y CR.</b>	P77 1 14 N P77 1 14 N Y P77
12	To Exit this Program: Press # # <b>CR.</b>	

**IMPORTANT NOTE:**

*For DK16 only: If all programs are initialized, the "IMDU enabled" has also been turned off in Program 77-1, LED 14. If using the IMDU for remote programming, go into Program 77-1 and turn button/LED 14 on as shown in steps 9, 10, and 11. If this is not completed, remote programming must be reactivated locally from the programming digital or electronic telephone.*

TABLE RM-E  
PROGRAM 92  
STATION SPEED DIAL, SPEED DIAL MEMO, VM ID CODES INITIALIZATION

STEP	ACTION	DISPLAY/PRINTOUT
1	Enter Program Mode At the >MODE prompt, enter <b>P R O G CR</b> .	>MODE PROG
2	Enter Program Number 92 Press <b>CR</b> .	P 92 P92
3	Enter <b>1</b> .	P92 P92 1
4	Enter button/LED number: <b>0 1</b> .	P92 P92 1 01 N
5	Change LED 01 to "ON" by entering <b>Y</b> .	P92 P92 1 01 N Y
6	Press <b>SPACE</b> two times.	P92 P92 1 01 N Y 02 N 03 N
7	Change LED 03 to "ON" by entering <b>Y</b> .	P92 P92 1 01 N Y 02 N 03 N Y
8	Press <b>CR</b> . Initialization complete. <i>NOTE: If program data is not entered correctly, <b>CR</b> will not respond. To retry, press <b>DELETE CR</b> at the same time.</i>	P92 P92 1 01 N Y 02 N 03 N Y P92
9	Clear system speed dial using the procedure on the next page.	

TABLE RM-F  
PROGRAM 92 (continued)  
SYSTEM SPEED DIAL, SPEED DIAL MEMO INITIALIZATION

STEP	ACTION	DISPLAY/PRINTOUT
1	Enter Program Mode At the >MODE prompt, enter <b>P R O G CR</b> .	>MODE PROG
2	Enter Program Number 92 Press <b>CR</b> .	P 92 P92
3	Enter <b>2</b> .	P92 P92 2
4	Enter button/LED number <b>0 1</b> .	P92 P92 2 01 N
5	Change LED 01 to "ON" by entering <b>Y</b> .	P92 P92 2 01 N Y
6	Press <b>SPACE</b> three times.	P92 P92 2 01 N Y 02 N 03 N 04 N
7	Change LED 04 to "ON" by entering <b>Y</b> .	P92 P92 2 01 N Y 02 N 03 N 04 N Y
8	Press <b>CR</b> . Initialization complete. <i>NOTE: If program data is not entered correctly, CR will not respond. To retry, press DELETE CR at the same time.</i>	P92 P92 2 01 N Y 02 N 03 N 04 N Y P92
9	Clear LCD message memory, using the procedure on the next page.	

REMOTE ADMINISTRATION AND MAINTENANCE PROCEDURES  
SECTION 100-816-600  
MARCH 1993

TABLE RM-G  
PROGRAM 92 (continued)  
LCD CHARACTER MESSAGE MEMORY INITIALIZATION

STEP	ACTION	DISPLAY/PRINTOUT
1	Enter Program Mode At the >MODE prompt, enter <b>P R O G CR</b> .	>MODE PROG
2	Enter Program Number 92 Press <b>CR</b> .	P 92 P92
3	Enter <b>3</b> .	P92 P92 3
4	Enter button/LED number <b>0 2</b> .	P92 P92 3 02 N
5	Change LED 02 to "ON" by entering <b>Y</b> .	P92 P92 3 02 N Y
6	Press <b>SPACE</b> .	P92 P92 3 02 N Y 03 N
7	Change LED 03 to "ON" by entering <b>Y</b> .	P92 P92 3 02 N Y 03 N Y
8	Press <b>CR</b> . Initialization complete. <i>NOTE: If program data is not entered correctly, CR will not respond. To retry, press <b>DELETE CR</b> at the same time.</i>	P92 P92 3 02 N Y 03 N Y P92
9	Clear the timed reminders using the procedure on the next page.	

TABLE RM-H  
PROGRAM 92 (continued)  
TIMED REMINDERS INITIALIZATION

STEP	ACTION	DISPLAY/PRINTOUT
1	Enter Program Mode At the >MODE prompt, enter <b>P R O G CR</b> .	>MODE PROG
2	Enter Program Number 92 Press <b>CR</b> .	P 92 P92
3	Enter <b>4</b> .	P92 P92 4
4	Enter button/LED number <b>0 2</b> .	P92 P92 4 02 N
5	Change LED 02 to "ON" by entering <b>Y</b> .	P92 P92 4 02 N Y
6	Press <b>SPACE</b> two times.	P92 P92 4 02 N Y 03 N 04 N
7	Change key 04 to "ON" by entering <b>Y</b> .	P92 P92 4 02 N Y 03 N 04 N Y
8	Press <b>CR</b> . Initialization complete.  <i>NOTE: If program data is not entered correctly, <b>CR</b> will not respond. To retry, press <b>DELETE CR</b> at the same time.</i>	P92 P92 4 02 N Y 03 N 04 N Y P92
9	To exit this program, press <b># # CR</b> .	

TABLE RM-1  
PROGRAM 92 (continued)  
DIGITAL TELEPHONE VOLUME LEVEL INITIALIZATION

STEP	ACTION	DISPLAY/PRINTOUT
1	Enter Program Mode At the >MODE prompt, enter <b>P R O G CR.</b>	>MODE PROG P
2	Enter Program Number 92 Press <b>CR.</b>	P 92 P92
3	Enter <b>5.</b>	P92 5
4	Enter <b>0 1</b> ; change button/LED 01 to "ON" by entering <b>Y.</b>	P92 5 01 N Y
5	Press <b>SPACE</b> four times.	P92 5 01 N Y 02 N 03 N 04 N 05 N
6	Change LED 05 to "ON" by entering <b>Y.</b>  <i>NOTE: If program data is not entered correctly, <b>CR</b> will not respond. To retry, press <b>DELETE CR</b> at the same time.</i>	P92 5 01 N Y 02 N 03 N 04 N 05 N Y
7	Press <b>CR.</b> Initialization complete.	P92 5 01 N Y 02 N 03 N 04 N 05 N P92
8	To exit this program, press <b># # CR.</b>	

TABLE RM-J  
PROGRAM 92 (continued)  
CALL FORWARD BACKUP RAM INITIALIZATION

STEP	ACTION	DISPLAY/PRINTOUT
1	Enter Program Mode At the >MODE prompt, enter <b>P R O G CR.</b>	>MODE PROG
2	Enter Program Number 92 Press <b>CR.</b>	P 92 P92
3	Enter <b>9.</b>	P92 P92 9
4	Enter button/LED number <b>0 3.</b>	P92 P92 9 03 N
5	Change LED 03 to "ON" by entering <b>Y.</b>	P92 P92 9 03 N Y
6	Press <b>SPACE.</b>	P92 P92 9 03 N Y 04 N
7	Change LED 04 to "ON" by entering <b>Y.</b>	P92 P92 9 03 N Y 04 N Y
8	Press <b>CR.</b> Initialization complete.  <i>NOTE: If program data is not entered correctly, <b>CR</b> will not respond. To retry, press <b>DELETE CR</b> at the same time.</i>	P92 P92 9 03 N Y 04 N Y P92
9	To exit this program, press <b># # CR.</b>	

**IMPORTANT NOTE:**

*This program clears Call Forward memory for all stations, but does not reset the Call Forward indication on the station (Call Forward LCD information and/or Call Forward button/LED). To clear station Call Forward indications, system power must be turned OFF for five seconds, then ON. Fixed Call Forward is not cleared by this program.*



TABLE RM-K  
PROGRAM 03  
SLOT ASSIGNMENTS

STEP	ACTION	DISPLAY/PRINTOUT
1	<b>Enter the Program Mode</b> At the >MODE prompt, enter <b>P R O G C R</b> .	>MODE PROG P
2	<b>Enter Program Number 03</b> Press <b>CR</b> .	P 03 P03
3	<b>Enter the Slot Number</b> Refer to the System Record Sheet and enter the desired slot number. Example: Slot number 00, enter <b>0 0</b> .	P03 P03 00 91
4	<b>Enter the PCB Code Number</b> Refer to the System Record Sheet and enter the desired PCB code number. Example: PCB code 92, enter <b>9 2</b> .	P03 P03 00 91 92
5	<b>To Exit Program/Store Data</b> A) To store data, press <b>CR</b> . B) Continue returning to Step 3 until all <b>Program 03</b> data is entered. C) To exit this program, press <b># #</b> , press <b>CR</b> .	P03 P03 00 91 92 P03 ## P
6	Turn system power "OFF" for 5 seconds and then turn power "ON" to store data in working memory (see Notes).	Remote maintenance is disconnected.

**IMPORTANT NOTES:**

- 1. This program only applies to DK16 and must be completed with on-site assistance (after installing PCBs, if any) because the system must be powered down momentarily after PCB code entry.*
- 2. Even though PCB codes display as being changed, they are not entered into working memory until the system DC power is cycled OFF and ON.*
- 3. If PCB codes are not entered into working memory by cycling DC power, PCB options will not function.*
- 4. Only Program 03 requires the system power to be turned OFF and ON to store data into working memory.*

**TABLE RM-L  
PROGRAM 00  
SOFTWARE CHECK/REMOTE MAINTENANCE—SECURITY CODE**

STEP	ACTION	DISPLAY/PRINTOUT
1	Enter Program Mode At the >MODE prompt, enter <b>P R O G CR.</b>	>MODE PROG P
2	Enter Program Number 00 Press <b>CR.</b>	P 00 P00
3	<b>To Check Software Version</b> Enter Action Code 0. System will display the system's software version. Press <b>CR.</b>	P00 0 Version = PSSA <input type="checkbox"/> · <input type="checkbox"/> P00 or Version = QMA <input type="checkbox"/> <input type="checkbox"/> Software version For DK16, PSSA. For DK8, QMA
4	<b>To Change Level 1 Security Code</b> Enter Action Code 1. The system will display the present level 1, four-digit code. Refer to the System Record Sheet and change if required. Press <b>CR.</b>	P00 1 0000 P00
5	<b>To Change Level 2 Security Code</b> Enter Action Code 2. The system will display the present level 2, four-digit code. Refer to the System Record Sheet and change if required. Press <b>CR.</b>	P00 2 0000 P00
6	<b>To Exit This Program</b> Press # # <b>CR.</b>	P00 ## P

TABLE RM-M  
PROGRAM 01  
LOGICAL PORT DISPLAY

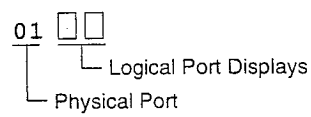
STEP	ACTION	DISPLAY/PRINTOUT
1	Enter the Program Mode At the >MODE prompt, enter <b>P R O G CR</b> .	>MODE PROG P
2	Enter Program Number 01 Press <b>CR</b> .	P 01 P01
3	Enter the Physical Port Number Enter the desired physical port number. Example: Port number 01, enter <b>0 1</b> .	P01 P01 01 <input type="checkbox"/> <input type="checkbox"/> 
4	Verify Physical Port's Associated Logical Port	P01 01 <input type="checkbox"/> <input type="checkbox"/> ( <input type="checkbox"/> <input type="checkbox"/> = Logical Port)
5	To Display More Ports/Exit Program A) To display more logical ports, press <b>CR</b> and go to Step 3. B) To exit this program, enter <b># # CR</b> (twice).	P01 01 <input type="checkbox"/> <input type="checkbox"/> ## P01 ## P (after exit)

TABLE RM-N  
PROGRAM 02  
PHYSICAL PORT DISPLAY

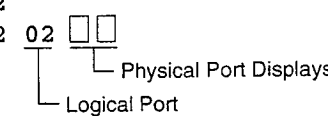
STEP	ACTION	DISPLAY/PRINTOUT
1	Enter the Program Mode At the >MODE prompt, enter <b>P R O G CR</b> .	>MODE PROG P
2	Enter Program Number 02 Press <b>CR</b> .	P 02 P02
3	Enter the Logical Port Number Enter the desired logical port number. Example: Port number 02, enter <b>0 2</b> .	P02 P02 02 <input type="checkbox"/> <input type="checkbox"/> 
4	Verify Logical Ports Associated Physical Port	P02 02 <input type="checkbox"/> <input type="checkbox"/> ( <input type="checkbox"/> <input type="checkbox"/> = Physical Port)
5	To Display More Ports/Exit Program A) To display more physical ports, press <b>CR</b> and go to Step 3. B) To exit this program, enter <b># # CR</b> (twice).	P02 02 <input type="checkbox"/> <input type="checkbox"/> ## P02 ## P (after exit)

TABLE RM-0  
PROGRAM 04  
PORT/STATION NUMBER ASSIGNMENT

STEP	ACTION	DISPLAY/PRINTOUT
1	Enter the Program Mode At the >MODE prompt enter <b>P R O G CR.</b>	>MODE PROG P
2	Enter Program Number 04 Press <b>CR.</b>	P 04 P04
3	Enter the Logical Port Number Refer to the System Record Sheet and enter the desired logical port number. Example: Port number 01, enter <b>0 1.</b>	P04 P04 01
4	Press <b>#</b> button. System displays present station number. Refer to the System Record Sheet and enter the desired station number. Example: Station number 16, enter <b>1 6.</b>	P04 P04 01# 11 06
5	To Exit Program/Store Data A) To store data; press <b>CR.</b> B) Continue returning to Step 3 until all Program 04 data is entered. C) To exit this program, press <b># # CR.</b>	P04 P04 01# 11 06 P04 ## P

NOTE:  
A blank is displayed by "N".

TABLE RM-P  
PROGRAM 05  
FLEXIBLE ACCESS CODE NUMBERING

STEP	ACTION	DISPLAY/PRINTOUT
1	Enter the Program Mode At the >MODE prompt, enter <b>P R O G CR.</b>	>MODE PROG
2	Enter Program Number 05 Press <b>CR.</b>	P 05 P05
3	Enter Access Code number that you wish to change (0 ~ 9) Example: 4 (if it was not previously changed, the system will print another 4. If it has been previously changed, the system will print the number to which it was changed).	P05 4 4
4	Change the number if required (one or two digits) Example: Change to 6, press <b>CR.</b>	P05 4 4 6
5	Continue returning to Step 3 until all required access codes have been changed.	
6	To Exit this Program Press <b># # CR.</b>	P

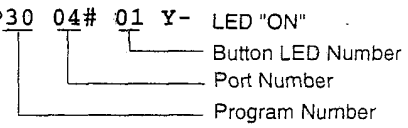
NOTE:  
Programs 10-1, 10-2, and 10-3 use Type 1 procedure.

TABLE RM-Q  
TYPE 1 PROGRAM PROCEDURE EXAMPLE  
(PROGRAMS: 10-1, 10-2, 10-3, 15, 16, 42-0, 77-1, 77-2)

STEP	ACTION	DISPLAY/PRINTOUT
1	Enter Program Mode At the >MODE prompt, enter <b>P R O G CR</b> .	>MODE PROG P
2	Enter Program Number Refer to the record sheet and enter the desired program number. Example: Program 10-1, enter <b>1 0</b> , press <b>CR</b> .	P 10 P10
3	Enter Program Code or Digit(s) Per Record Sheet <b>1</b> or other digit required. <i>NOTE: Most programs do not require a second digit.</i>	P10 1
4	Enter Button/LED Number Enter the desired button/LED number. Example: Button/LED 01, enter <b>0 1</b> .	P10 1 01 N (see note)
5	To Change Button/LED Status Refer to the System Record Sheet and change the button/LED status, if required (Y or N). Example: Enter <b>Y</b> .	P10 1 01 N Y
6	To Advance to Next Button/LED Press <b>SPACE</b> . Repeat step 5 if necessary.	P10 1 01 Y 02 N
7	To Review Button/LED Status Change Enter <b>CR</b> . Re-enter Steps 3 and 4. <i>NOTE: This step is optional and not required to save data.</i>	P10 1 01 Y- Button LED "ON" Button LED Number Program Code Program Number
8	To Exit Program/Store Data A) To store data, press <b>CR</b> . B) To exit this program, press <b># #</b> , then press <b>CR</b> . C) Continue returning to step 2 until all Type 1 programs are completed.	P10 P10 ## P
9	To Exit the Program Mode Press <b># # CR</b> .	> MODE
10	To Enter Another Mode Press <b>D U M P CR</b> (data dump) <b>T E S T CR</b> (test) <b>M E S G CR</b> (LCD messages) <b>R E P T CR</b> (speed dial)	D T (no prompt) R

NOTE:  
Y = button/LED "ON", N = button/LED "OFF"

TABLE RM-R  
TYPE 2 PROGRAM PROCEDURE EXAMPLE  
(PROGRAMS: 20, 30, 31, 35, 40, 41, 43, 79, 81 ~ 89)

STEP	ACTION	DISPLAY/PRINTOUT
1	<b>Enter Program Mode</b> At the >MODE prompt, enter <b>P R O G CR.</b>	>MODE PROG P
2	<b>Enter Program Number</b> Refer to the record sheet and enter the desired program number. Example: <b>Program 30</b> , enter <b>3 0</b> , press <b>CR.</b>	P 30
3	<b>Enter Port Number</b> <input type="checkbox"/> <input type="checkbox"/> or <b>Port Range</b> <input type="checkbox"/> <input type="checkbox"/> * <input type="checkbox"/> <input type="checkbox"/> Refer to the System Record Sheet and enter the desired port number(s). Example: <b>0 4.</b>	P30 P30 04
4	Press <b>#</b> button.	P30 04#
5	<b>Enter the Desired Button/LED Number</b> Example: Button/LED 01, enter: <b>0 1.</b>	P30 04# 01 N (Note)
6	<b>To Change Button/LED Status</b> Refer to the System Record Sheet and change the button/LED status, if required (Y or N). Example: Enter <b>Y.</b>	P30 04# 01 N Y
7	<b>To Advance to Next Button/LED</b> Press <b>SPACE</b> (repeat Step 6 if necessary).	
8	<b>To Review Button/LED Status Change</b> Press <b>CR.</b> Re-enter Steps 3, 4, and 5.	P30 04# 01 Y- LED "ON" 
9	<b>To Exit Program/Store Data</b> A) To store data, press <b>CR.</b> B) To exit this program, press <b># #</b> , then press <b>CR.</b> C) Continue returning to Step 2 until all Type 2 programs are completed.	P10 P10 ## P
10	<b>To Exit the Program Mode</b> Press <b># # CR.</b>	>MODE
11	<b>To Enter Another Mode,</b> Press  <b>D U M P CR</b> (data dump) <b>T E S T CR</b> (test) <b>M E S G CR</b> (LCD messages) <b>R E P T CR</b> (speed dial)	D T (no prompt) R

**NOTE:**

Y = button/LED(s) "ON", N = button/LED(s) "OFF"; U = button/LED(s) "ON" some ports and "OFF" other ports.

TABLE RM-S  
PROGRAM 12  
SYSTEM ASSIGNMENTS – BASIC TIMING

STEP	ACTION	DISPLAY/PRINTOUT
1	<b>Enter the Program Mode</b> At the >MODE prompt, enter <b>P R O G CR.</b>	>MODE PROG P
2	<b>Enter Program Number 12</b> Press <b>CR.</b>	P 12 P12
3	Check the record sheet and enter the program code that is required. As an example, feature 3, enter <b>3.</b> The present selection will be displayed.	P12 3 1
4	Refer to the record sheet and change if required. As an example, change it to 2. Enter <b>2.</b>	P12 3 1 2
5	<b>To Exit Program/Store Data</b> A) To store data, press <b>CR.</b> B) Continue returning to Step 3 until all <b>Program 12</b> data is entered. C) To exit this program, press <b># # CR.</b>	P12 3 1 2 P12 ## P

TABLE RM-T  
PROGRAM 13  
DEFINING THE MESSAGE CENTER

STEP	ACTION	DISPLAY/PRINTOUT
1	<b>Enter the Program Mode</b> At the >MODE prompt, enter <b>P R O G CR.</b>	>MODE PROG P
2	<b>Enter Program Number 13</b> Press <b>CR.</b>	P 13 P13
3	Enter the number <b>1.</b> The present port number will be displayed.	P13 P13 1 NN
4	Refer to the record sheet and enter the required port number. Example: Port 00, enter <b>0 0 CR.</b>	P13 1 NN 00 P13
5	<b>To Exit this Program</b> Press <b># # CR.</b>	P13 1 NN 00 P13 ## P

**NOTES:**

1. A blank is displayed by "N".
2. **Programs 15 and 16** use Type 1 procedure.

TABLE RM-U  
PROGRAM 19  
BACKGROUND MUSIC SLOT IDENTIFICATION

STEP	ACTION	DISPLAY/PRINTOUT
1	Enter the Program Mode At the >MODE prompt, enter <b>P R O G CR.</b>	>MODE PROG P
2	Enter Program Number 19 Press <b>CR.</b>	P 19 P19
3	Enter the number <b>1.</b> The present slot number will be displayed.	P19 P19 1 NN
4	Refer to the record sheet and enter the required slot number. Example: Slot 04, enter <b>0 4 CR.</b>	P19 1 NN 04 P19
5	To Exit this Program Press <b># # CR.</b>	P1 19 ## P

NOTE:

Program 20 uses Type 2 procedure.

TABLE RM-V  
PROGRAM 21  
MODEM POOLING

STEP	ACTION	DISPLAY/PRINTOUT
1	Enter Program Mode At the >MODE prompt, enter <b>P R O G CR.</b>	>MODE PROG P
2	Enter Program Number 21 Press <b>CR.</b>	P 21 P21
3	Refer to the System Record Sheet, and enter the required port number for the PDIU-DS. Example: port 04; Enter: <b>0 4.</b>	P21 04
4	Press <b>#.</b> The system will display the presently selected standard telephone port number.	P21 04 # NN
5	Refer to the System Record Sheet, and enter the required standard telephone port number. Example: Port 08; Enter: <b>0 8.</b>	P21 04 # NN 08
6	To Exit Program/Store Data A) To store data, press <b>CR.</b> B) Continue returning to Step 3 until all Program 21 data is entered. C) To exit this program, press <b># # CR.</b>	P21 04 # NN 08 P21 ## P



REMOTE ADMINISTRATION AND MAINTENANCE PROCEDURES  
SECTION 100-816-600  
MARCH 1993

TABLE RM-W  
PROGRAM 22  
DATA STATION HUNTING (DATA CALL ONLY)

STEP	ACTION	DISPLAY/PRINTOUT
1	Enter the Program Mode At the >MODE prompt, enter <b>P R O G CR.</b>	>MODE PROG P
2	Enter Program Number 22 Press <b>CR.</b>	P 22 P22
3	Refer to the record sheet and enter the required port number. Example: Port 03, enter <b>0 3.</b>	P22 03
4	Enter <b>#</b> . The present data will be displayed.	P22 03# NN
5	Refer to the record sheet and enter the port number that will be the hunt point. Example: Port 00, enter <b>0 0.</b>	P22 03# NN 00
6	<b>To Exit Program/Store Data</b> A) To store data, press <b>CR.</b> B) Continue returning to step 3 until all Program 22 data is entered. C) To exit this program, press <b># # CR.</b>	P22 03# NN 00 P22 ## P

TABLE RM-X  
PROGRAM 28  
DSS CONSOLE/ATTENDANT TELEPHONE ASSIGNMENTS

STEP	ACTION	DISPLAY/PRINTOUT
1	Enter Program Mode At the >MODE prompt, enter <b>P R O G CR.</b>	>MODE PROG P
2	Enter Program Number 28 Press <b>CR.</b>	P 28 P28
3	Refer to the System Record Sheet and enter the required DSS console number (1 ~ 2). The system will display the telephone to which the DSS console is assigned. Example: DSS console number 1 is assigned to telephone number 1. Refer to the System Record Sheet and change if required. Example: Assign DSS console 1 to electronic telephone 2. Enter: <b>2.</b>	P28 1 1 2
4	<b>To Exit Program/Store Data</b> A) To store data, press <b>CR.</b> B) Continue returning to Step 3 until all data has been entered for this program. C) To exit this program, press <b># # CR.</b>	P28-1 1 2 P28 ## P

NOTE:

This program applies to digital and electronic DSS consoles and digital and electronic telephones.

TABLE RM-Y  
PROGRAM 29  
DSS CONSOLE BUTTON ASSIGNMENTS

STEP	ACTION	DISPLAY/PRINTOUT
1	Enter Program Mode At the >MODE prompt, enter <b>P R O G CR</b> .	>MODE PROG P
2	Enter Program Number Press <b>2 9 CR</b> .	P 29 P29
3	Enter Console Number and Buttonstrip Group Number Press <input type="text"/> <input type="text"/> <div style="margin-left: 40px;"> <input type="text"/> Button Group Number (1 ~ 3)  <input type="text"/> Console Number (1 ~ 2) </div>	P29 <input type="text"/> <input type="text"/>
4	Enter the 2-digit Button Number to be Programmed (01 ~ 20): <input type="text"/> <input type="text"/> (current feature code displays <input type="text"/> <input type="text"/> <input type="text"/> after button entry).	P29 <input type="text"/> <input type="text"/> <input type="text"/> <input type="text"/> <input type="text"/> <input type="text"/> Key code
5	Enter New (2- or 3-digit) Feature Code Press <input type="text"/> <input type="text"/> or <input type="text"/> <input type="text"/> <input type="text"/> <div style="margin-left: 40px;"> <input type="text"/> 3-digit code  <input type="text"/> 2-digit code </div>	P29 <input type="text"/> <input type="text"/> <input type="text"/> <input type="text"/> <input type="text"/> <input type="text"/> <input type="text"/> <input type="text"/> <div style="margin-left: 20px;"> <input type="text"/> Console Button Old New  <input type="text"/> No. code code code  <input type="text"/> Button group </div>
6	Press <b>SPACE</b> to go to next button. or Press <b>CR</b> to store data.	P29
7	Continue with Step 3 until all <b>Program 29</b> data is entered.	
8	To Exit this Program Press <b># # CR</b> .	

NOTE:  
Programs 30 and 31, use Type 1 procedure.

REMOTE ADMINISTRATION AND MAINTENANCE PROCEDURES  
SECTION 100-816-600  
MARCH 1993

TABLE RM-Z  
PROGRAM 32  
AUTOMATIC PREFERENCE

STEP	ACTION	DISPLAY/PRINTOUT
1	<b>Enter the Program Mode</b> At the >MODE prompt, enter <b>P R O G CR.</b>	>MODE PROG P
2	<b>Enter the Program Number 32</b> Press <b>CR.</b>	P 32 P32
3	Refer to the record sheet and enter the required port number. Example: Port 01, enter <b>0 1.</b>	P32 01
4	Enter <b>#.</b> The present status for this port will be displayed.	P32 01# 100
5	Refer to the record sheet and enter the required ringing code. Example: Code 0, enter <b>0.</b>	P32 01 # 100 0
6	Refer to the record sheet and enter the required automatic off-hook code. Example: Code 11, enter <b>1 1.</b>	P32 01# 100 011
7	<b>To Exit Program/Store Data</b> A) To store data, press <b>CR.</b> B) Continue returning to step 3 until all <b>Program 32</b> data is entered. C) To exit this program, press <b># # CR.</b>	P32 01# 100 011 P32 ## P

TABLE RM-AA  
PROGRAM 33  
STATION HUNTING

STEP	ACTION	DISPLAY/PRINTOUT
1	<b>Enter the Program Mode</b> At the >MODE prompt, enter <b>P R O G CR.</b>	>MODE PROG P
2	<b>Enter Program Number 33</b> Press <b>CR.</b>	P 33 P33
3	Refer to the record sheet and enter the required port number. Example: Port 03, enter <b>0 3.</b>	P33 03
4	Enter <b>#.</b> The present data will be displayed.	P33 03# NN
5	Refer to the record sheet and enter the port number that will be the hunt point. Example: Port 00, enter <b>0 0.</b>	P33 03# NN 00
6	<b>To Exit Program/Store Data</b> A) To store data, press <b>CR.</b> B) Continue returning to step 3 until all <b>Program 33</b> data is entered. C) To exit this program, press <b># # CR.</b>	P33 03# NN 00 P33 ## P

**TABLE RM-AB  
PROGRAM 34  
HOLD RECALL TIMING**

STEP	ACTION	DISPLAY/PRINTOUT
1	Enter the Program Mode At the >MODE prompt, enter <b>P R O G C R.</b>	>MODE PROG P
2	Enter Program Number 34 Press <b>CR.</b>	P 34 P34
3	Refer to the record sheet and enter the required port number. Example: Port 05, enter <b>0 5.</b>	P34 05
4	Press <b>#.</b> The present data will be displayed.	P34 05# 032
5	Refer to the record sheet and enter the required timing. Example: 160 seconds, enter <b>1 6 0.</b>	P34 05# 032 160
6	<b>To Exit Program/Store Data</b> A) To store data, press <b>CR.</b> B) Continue returning to step 3 until all <b>Program 34</b> data has been entered. C) To exit this program, press <b># # CR.</b>	P34 05# 032 160 P34 ## P

**NOTE:**

*Program 35, use Type 2 procedure.*

**TABLE RM-AC  
PROGRAM 36  
FIXED CALL FORWARD**

STEP	ACTION	DISPLAY/PRINTOUT
1	Enter the Program Mode At the >MODE prompt, enter <b>P R O G C R.</b>	>MODE PROG P
2	Enter Program Number 36 Press <b>CR.</b>	P 36 P36
3	Refer to the System Record Sheet and enter the port number for the station that will have a Fixed Call Forward button. Example: Port 00, enter <b>0 0.</b>	P36 00
4	Press <b>#.</b> The present data will be displayed.	P36 00# NN
5	Refer to the System Record Sheet and enter the port to be forwarded to when the Fixed Call Forward button is pressed. Example: Port 04, enter <b>0 4.</b>	P36 00# NN 04
6	<b>To Exit Program/Store Data</b> A) To store data, press <b>CR.</b> B) Continue returning to step 3 until all <b>Program 36</b> data is entered. C) To exit this program, press <b># # CR.</b>	P36 00# NN 04 P36 ## P

TABLE RM-AD  
PROGRAM 37  
RING TRANSFER (CAMP-ON) RECALL TIME

STEP	ACTION	DISPLAY/PRINTOUT
1	<b>Enter the Program Mode</b> At the >MODE prompt, enter <b>P R O G CR.</b>	>MODE PROG P
2	<b>Enter the Program Number 37</b> Press <b>CR.</b>	P 37 P37
3	Refer to the System Record Sheet and enter the required port number. Example: Port 01, enter <b>0 1.</b>	P37 .01
4	Press <b>#.</b> System will display the present ring transfer recall time.	P37 01# 064
5	Refer to the System Record Sheet and enter the required ring transfer timeout. Example: 70 seconds. Enter <b>0 7 0.</b>	P37 01# 064 070
6	<b>To Exit Program/Store Data</b> A) To store data, press <b>CR.</b> B) Continue returning to step 3 until all <b>Program 37</b> data is entered. C) To exit this program, press <b># # CR.</b>	P37 01# 064 070 P37 ## P

TABLE RM-AE  
PROGRAM 38  
DIGITAL AND ELECTRONIC TELEPHONE BUTTONSTRIP TYPE

STEP	ACTION	DISPLAY/PRINTOUT
1	<b>Enter the Program Mode</b> At the >MODE prompt, enter <b>P R O G CR</b> .	>MODE PROG P
2	<b>Enter the Program Number 38</b> Press <b>CR</b> .	P 38 P38
3	Refer to the System Record Sheet and enter the required port number. Example: Port 00, enter <b>0 0</b> .	P38 00
4	Press <b>#</b> . The system will display the present telephone code.	P38 00# 31
5	Refer to the System Record Sheet and enter the required telephone code number. Example: Code 21, enter <b>2 1</b> .	P38 00# 31 21
6	<b>To Exit Program/Store Data</b> A) To store data, press <b>CR</b> . B) Continue returning to step 3 until all Program 38 data is entered. C) To exit this program, press <b># # CR</b> .	P38 00# 31 21 P38 ## P

TABLE RM-AF  
PROGRAM 39  
FLEXIBLE BUTTON ASSIGNMENT

STEP	ACTION	DISPLAY/PRINTOUT
1	Enter the Program Mode At the >MODE prompt, enter <b>P R O G CR</b> .	>MODE PROG P
2	Enter the Program Number 39 Press <b>CR</b> .	P 39 P39
3	Refer to the System Record Sheet and enter the required port number. Example: Port 00, enter <b>0 0</b> .	P39 00
4	Press <b>#</b> .	P39 00#
5	Refer to the System Record Sheet and enter the button number. Example: Button 01, enter <b>0 1</b> . The system will display the feature code presently assigned to this button.	P39 00# 01 00
6	Refer to the System Record Sheet and enter the required feature code (2 or 3 digits). Example: Code 01, enter <b>0 1</b> .	P39 00# 01 00 01
7	To select the next button number, press <b>SPACE</b> . Continue returning to step 6 until all port 00 features are programmed.	P39 00# 01 00 01 02 02
8	Press <b>CR</b> to store data.	P39
9	A) Continue returning to step 3 until all <b>Program 39</b> data has been entered. B) To exit this program and store data, press <b># # CR</b> .	P39 00# 01 00 01 02 02 P39 ## P

NOTES:

1. **Program 40, 41:** use Type 2 procedure.
2. **Program 42-0:** use Type 1 procedure.

TABLE RM-AG  
PROGRAM 42-1 ~ 8  
PBX ACCESS CODE

STEP	ACTION	DISPLAY/PRINTOUT
1	<b>Enter Program Mode</b> At the >MODE prompt, enter <b>P R O G CR.</b>	>MODE PROG P
2	<b>Enter Program Number 42</b> Press <b>CR.</b>	P 42 P42
3	Refer to the System Record Sheet and enter the required PBX group number (1 ~ 8). System will display present PBX access code.	P42 1 NN
4	Refer to the System Record Sheet and enter the required access code. N = Space # = Don't care Example: 9, enter <b>9 N.</b>	P42 1 NN 9N
5	<b>To Exit Program/Store Data</b> A) To store data press <b>CR.</b> B) Return to step 3 to continue in this program. C) To exit this program, press <b># # CR.</b>	P42 1 NN 9N P42 ## P



REMOTE ADMINISTRATION AND MAINTENANCE PROCEDURES  
SECTION 100-816-600  
MARCH 1993

TABLE RM-AH  
PROGRAM 60  
SMDR OUTPUT/ACCOUNT CODE DIGIT LENGTH

STEP	ACTION	DISPLAY/PRINTOUT
1	Enter Program Mode At the >MODE prompt, enter <b>P R O G CR</b> .	>MODE PROG P
2	Enter Program Number 60 Press <b>CR</b> .	P 60 P60
3A	<b>SMDR Threshold Time</b> <b>Enter: Item code 2.</b> The system will display either "0" or "1". "0" indicates that the threshold time is set at 0.1 seconds. "1" indicates 10 seconds. The default is "1". Refer to the System Record Sheet, and enter the correct digit—if it is not already being displayed—and then <b>CR</b> . If you wish to change another parameter within this program, enter its associated item code. To exit this program, go to step 4.	P60 21
3B	<b>Allow SMDR printout.</b> <b>Enter: Action code 3.</b> System will print out "1" if incoming and outgoing calls will be printed on SMDR. A "0" will be printed out if only outgoing calls will be printed. Refer to the System Record Sheet and change (to 1 or 0), if required, and press <b>CR</b> . If you wish to change another parameter within this program, enter its associated item code. To exit this program, go to step 4.	P60 3 1 P60
3C	<b>Set Account Code Digit Length</b> <b>Enter: Item code 4.</b> The system will display the number of digits allowed in the account code. The default is 06. Refer to the System Record Sheet and enter the required number of digits (04 ~ 15) and press <b>CR</b> . If you wish to change another parameter within this program, enter its associated item code. To exit this program, go to step 4.	P60 4 06
3D	<b>SMDR Toll Calls Only</b> <b>Enter: Action code 5.</b> The system will display the presently selected feature (0 ~ 5). The default is 0. Refer to the System Record Sheet and enter the required feature code and press <b>CR</b> . If you wish to change another parameter within this program, enter its associated item code. To exit this program, go to step 4.	P60 5 0
3E	<b>Enter DISA ID Code</b> <b>Enter: Item code 6.</b> System will display last entered ID code number. Default = Blank. Refer to the System Record Sheets, and enter a new code if desired, and then press <b>CR</b> . If you wish to change another parameter within this program, enter its associated item code. To exit this program, go to step 4.	P60 6 NNNN
3F	<b>Credit Card Call Digit Length</b> <b>Enter: Item code 7.</b> The system will display the current digit length. Refer to the System Record Sheet, and enter the desired length, 01 ~ 30 digits, and then <b>CR</b> . Example: 13 digits: enter <b>1 3 CR</b> . If you wish to change another parameter within this program, enter its associated item code. To exit this program, go to step 4.	P60 7 13
4	<b>To Exit Program/Store Data</b> Press <b># # CR</b> .	P60 6 NNNN P60 ## P

TABLE RM-AI  
PROGRAM 69  
VERIFIABLE ACCOUNT CODE ENTRY

STEP	ACTION	DISPLAY/PRINTOUT
1	<b>Enter Program Mode</b> At the >MODE prompt, enter <b>P R O G C R</b> .	>MODE PROG P
2	<b>Enter Program Number 69</b> Press <b>CR</b> .	P 69 P69
3	Refer to the System Record Sheet, and enter the required code number (000 ~ 299). Example: code number 001; Enter: <b>0 0 1</b> . The system will display the present account code number assigned to 001. <i>Note:</i> <i>The number of digits will be as defined in Program 60-4.</i>	P69 001 NNNNNNNNNNNNNNNN
4	A) Refer to the System Record Sheets, and enter the required account code number. Example: number 987654; Enter: <b>9 8 7 6 5 4</b> . B) To clear and erase all data enter (all caps) <b>NNNNNNNNNNNNNNNN</b> .	P69 001 NNNNNN 987654
5	<b>To Exit Program/Store Data</b> A) To store data, press <b>CR</b> . B) Continue returning to step 3 until all <b>Program 69</b> data is entered. C) To exit this program, press <b># # CR</b> .	P69 001 NNNNNN 987654 P69 ## P

TABLE RM-AJ  
PROGRAM 70  
VERIFY ACCOUNT CODE/TOLL RESTRICTION ASSIGNMENT

STEP	ACTION	DISPLAY/PRINTOUT
1	<b>Enter Program Mode</b> At the >MODE prompt, enter <b>P R O G CR</b> .	>MODE PROG P
2	<b>Enter Program Number 70</b> Press <b>CR</b> .	P 70 P70
3	Refer to the System Record Sheet, and enter the required code number (000 ~ 299). Example: code number 002; Enter: <b>0 0 2</b> . The system will display the present digit Restrict (Y) and Toll Restriction Status (Z) for entered code number.	P70 002 YZ
4	Refer to the System Record Sheet, and enter the required digit Restrict and Toll Restriction data. Example: digit Restrict (1) and Toll Restriction (3); Enter: <b>1 3</b> .	P70 002 YZ 13
5	<b>To Exit Program/Store Data</b> A) To store data, press <b>CR</b> . B) Continue returning to step 3 until all <b>Program 70</b> data is entered. C) To exit this program, press <b># # CR</b> .	P70 002 YZ 13 P70 ## P

**NOTE:**

*Programs 77-1 and 77-2, use Type 1 procedure.*

**TABLE RM-AK  
PROGRAM 78  
CO LINE SPECIAL RINGING ASSIGNMENTS-DISA/IMDU/  
NIGHT RINGING OVER EXTERNAL PAGE**

STEP	ACTION	DISPLAY/PRINTOUT
1	Enter Program Mode At the >MODE prompt, enter <b>P R O G CR.</b>	>MODE PROG P
2	Enter Program Number 78 Press <b>CR.</b>	P 78 P78
3	Refer to the System Record Sheet and enter the feature number for the feature to be programmed. Example: Feature code 1, enter <b>1.</b>	P78 1
4	Refer to the System Record Sheet and enter the code number for the area of the feature being programmed. Example: Code 3, enter <b>3.</b>	P78 13
5	Refer to the System Record Sheet and enter the CO line buttons that will be associated with this feature. Example: CO button 01, enter <b>0 1.</b> The system will designate whether the CO button/LED is on/off. Refer to the System Record Sheet and change if required. Press <b>SPACE</b> to display next CO button/LED.	P78 13 01 N 02 N Y
6	<b>To Exit Program/Store Data</b> A) To store data, press <b>CR.</b> B) Continue returning to step 3 until all data has been entered for this program. C) To exit this program, press <b># # CR.</b>	P78 13 01 N 02 N Y P78 ## P

*NOTE:*  
*Program 79 uses Type 2 procedure.*

TABLE RM-AL  
PROGRAM 80  
DIGITAL AND ELECTRONIC TELEPHONE RINGING TONES

STEP	ACTION	DISPLAY/PRINTOUT
1	Enter Program Mode. At the >MODE prompt, enter <b>P R O G CR</b> .	>MODE PROG P
2	Enter Program Number 80 Press <b>CR</b> .	P 80 P80
3	Refer to the System Record Sheet and enter the required port number. Example: Port 01, enter <b>0 1</b> .	P80 01
4	Press <b>#</b> key. The system will display 1 or 2 corresponding to tone 1 or tone 2.	P80 01# 1
5	Refer to the System Record Sheet and change if required. Example: Tone 2, enter <b>2</b> .	P80 01# 1 2
6	<b>To Exit Program/Store Data</b> A) To store data, press <b>CR</b> . B) Continue returning to step 3 until all data has been entered for this program. C) To exit this program, press <b># # CR</b> .	P80 01# 1 2 P80 ## P

*NOTE:*

*Programs 81 ~ 89 use Type 2 procedure.*

**TABLE RM-AM  
PROGRAM 93  
CO LINE IDENTIFICATION**

STEP	ACTION	DISPLAY/PRINTOUT
1	<b>Enter Program Mode</b> At the >MODE prompt, enter <b>P R O G CR</b> .	>MODE PROG P
2	<b>Enter Program Number 93</b> Press <b>CR</b> .	P 93 P93
3	<b>Enter Action Code 1</b> Refer to the System Record Sheet and enter the appropriate CO line number. Example: CO line 2, enter <b>0 2</b> . The system will display previously entered identification characters (up to 16 characters).	P93 1 02 <span style="border: 1px solid black; padding: 2px;">  </span> (up to 16) └─ Current I.D.
4	Refer to the System Record Sheet and change identification if required: <span style="border: 1px solid black; padding: 2px;">  </span> ..... <span style="border: 1px solid black; padding: 2px;">  </span> (16 characters maximum). Example: OVERSEAS.	P93 1 02 <span style="border: 1px solid black; padding: 2px;">  </span> (up to 16) OVERSEAS
5	<b>To Exit Program/Store Data</b> A) To store data, press <b>CR</b> . B) Continue returning to step 3 until all data has been entered for this program. C) To exit this program, press <b># # CR</b> .	P93 1 02 <span style="border: 1px solid black; padding: 2px;">  </span> (up to 16) OVERSEAS P93 ## P

*NOTE:*  
Use **SPACE** to clear characters.

TABLE RM-AN  
PROGRAM 44 (A OR B)  
TOLL RESTRICTION TRAVELING CLASS OVERRIDE CODE ENTRY

STEP	ACTION	DISPLAY/PRINTOUT
1	Enter Program Mode At the >MODE prompt, enter <b>P R O G CR.</b>	>MODE PROG P
2	Enter Program Number 44 (Do not enter A or B) Press <b>CR.</b>	P 44 P44
3	Refer to the System Record Sheet and enter the required Toll Restriction Class number (1 ~ 4). Example: Class 1; Enter: <b>1.</b> The system will display the present override code assigned to that class number.	P44 1 NNNN
4	Refer to the System Record Sheet and enter the required override code number. Example: 3456; Enter <b>3 4 5 6.</b>	P44 1 NNNN 3456
5	To Exit Program/Store Data A) To store data, press <b>CR.</b> B) Continue returning to step 3 until all Program 44 data is entered. C) To exit this program, press <b># # CR.</b>	P44 1 NNNN 3456 P44 ## P

TABLE RM-AO  
PROGRAM 45-1  
TOLL RESTRICTION DIAL PLAN

STEP	ACTION	DISPLAY/PRINTOUT
1	Enter the Program Mode At the >MODE prompt, enter <b>P R O G CR.</b>	>MODE PROG P
2	Enter Program Number 45 Press <b>CR.</b>	P 45 P45
3	Enter the number 1. The system will display the present dial plan code number (1 ~ 5).	P45 1 1
4	Refer to the record sheet and enter the required code number. Example: Code 2, enter <b>2.</b>	P45 1 1 2
5	To Exit Program/Store Data A) To store data, press <b>CR.</b> B) To exit this program, press <b># # CR.</b>	P45 1 1 2 P45 _## P

TABLE RM-AP  
PROGRAM 45-2  
TOLL RESTRICTION DISABLE

STEP	ACTION	DISPLAY/PRINTOUT
1	Enter the Program Mode At the >MODE prompt, enter <b>P R O G CR.</b>	>MODE PROG P
2	Enter Program Number 45 Press <b>CR.</b>	P 45 P45
3	Enter the number <b>2.</b>	P45 2
4	Refer to the record sheet and enter the required CO line number. Example: CO line 01, enter <b>0 1.</b> The system will display N or Y to define if the LED is on or off.	P45 2 01 N
5	Refer to the System Record Sheet and change the CO line status as required (Y or N). Press <b>SPACE</b> to step to next CO line number.	P45 2 01 N Y 02 N
6	<b>To Exit Program/Store Data</b> A) To store data, press <b>CR.</b> B) To exit this program, press <b># # CR.</b>	P45 2 01 N Y 02 N P45 ## P

TABLE RM-AQ  
PROGRAM 45-3 ~ 6  
EQUAL ACCESS, SPECIAL COMMON CARRIER NUMBERS, and AUTHORIZATION CODE DIGIT LENGTH

STEP	ACTION	DISPLAY/PRINTOUT
1	Enter Program Mode At the >MODE prompt, enter <b>P R O G CR.</b>	>MODE PROG P
2	Enter Program Number 45 Press <b>CR.</b>	P 45 P45
3	Refer to the record sheet and enter the item number (3 ~ 6). Example: Item 3, enter <b>3.</b> The system will display the present equal access number or EA1 Code.	P45 3 NNNNN
4	Refer to the System Record Sheet and enter the required number. Example: 12345, enter <b>1 2 3 4 5 CR.</b>	P45 3 NNNNN 12345 P45
5	Enter code number 4. The system will display present authorization code digit length. Refer to the System Record Sheet and enter the required authorization code number digit length. Example: 12, enter: <b>1 2 CR.</b>	P45 4 00 12 P45
6	To exit this program, press <b># # CR.</b>	P45 ## P

NOTE:

Items 5 and 6 are entered the same way as 3 and 4, respectively.



TABLE RM-AR  
PROGRAM 45-8 ~ 9  
TOLL RESTRICTION OVERRIDE CODE

STEP	ACTION	DISPLAY/PRINTOUT
1	Enter the Program Mode At the >MODE prompt, enter <b>P R O G CR</b> .	>MODE PROG P
2	Enter the Program Number 45 Press <b>CR</b> .	P 45 P45
3	Refer to the System Record Sheet and enter <b>8</b> or <b>9</b> for the desired code number. The system will display the present override code number.	P45 8 NNNN
4	Refer to the record sheet and enter a new number if required. Example: 1234. Enter: <b>1 2 3 4</b> .	P45 8 NNNN 1234
5	To Exit Program/Store Data A) To store data, press <b>CR</b> . B) To exit this program, press <b># # CR</b> .	P45 8 NNNN 1234 P45 ## P

TABLE RM-AS  
PROGRAM 46-2 ~ 4  
TOLL RESTRICTION ALLOWED/DENIED AREA CODES ASSIGNED BY CLASS

STEP	ACTION	DISPLAY/PRINTOUT
1	Enter Program Mode At the >MODE prompt, enter <b>P R O G CR</b> .	>MODE PROG P
2	Enter Program Number 46 Press <b>CR</b> .	P 46 P46
3	Enter class number (1 ~ 4).	P46 <input type="text"/> └─ Class Number
4	Enter <b>2, 3</b> , or <b>4 SPACE</b> • <b>2</b> — to add codes to memory (allow). • <b>3</b> — to delete codes from memory (deny). • <b>4 SPACE</b> — to display codes in memory (allowed codes).	P46 <input type="text"/> <input type="text"/> └─ 2, 3 or 4  ALLOW? or DENY?
5	Refer to the System Record Sheet and enter the area code or area code group. Single <input type="text"/> <input type="text"/> <input type="text"/> <input type="text"/> . Group <input type="text"/> <input type="text"/> <input type="text"/> * <input type="text"/> <input type="text"/> <input type="text"/> <input type="text"/> . Press <b>SPACE</b> to enter more codes.	P46 X Y ALLOW <input type="text"/> <input type="text"/> <input type="text"/> <input type="text"/> - <input type="text"/> <input type="text"/> <input type="text"/> <input type="text"/> or DENY
6	Press <b>SPACE</b> to temporarily store data. Press <b>CR</b> when completed.	P46
7	Continue returning to step 3 until all data input is completed for this program.	
8	To Exit this Program Press <b># # CR</b> .	P46 ## P

TABLE RM-AT  
PROGRAM 46-6 ~ 8  
TOLL RESTRICTION ALLOWED/DENIED OFFICE CODES ASSIGNED BY CLASS

STEP	ACTION	DISPLAY/PRINTOUT
1	Enter Program Mode At the >MODE prompt, enter <b>P R O G CR.</b>	>MODE PROG P
2	Enter Program Number 46 Press <b>CR.</b>	P 46 P46
3	Enter class number (1 ~ 4).	P46 <input type="checkbox"/> └─ Class Number (X)
4	Enter <b>6, 7, or 8 SPACE.</b> • <b>6</b> — to add codes to memory (allowed). • <b>7</b> — to delete codes from memory (deny). • <b>8 SPACE</b> — to display codes in memory (allowed codes).	P46 <input type="checkbox"/> <input type="checkbox"/> └─ 6, 7, or 8 (Y)
5	Refer to the System Record Sheet and enter the office code or office code group. Single <input type="checkbox"/> <input type="checkbox"/> <input type="checkbox"/> . Group <input type="checkbox"/> <input type="checkbox"/> * <input type="checkbox"/> <input type="checkbox"/> . Press <b>SPACE</b> to enter more codes.	P46 X Y ALLOW <input type="checkbox"/> <input type="checkbox"/> <input type="checkbox"/> - <input type="checkbox"/> <input type="checkbox"/> <input type="checkbox"/> or DENY
6	Press <b>SPACE</b> to temporarily store data. Press <b>SPACE</b> when completed.	P46
7	Continue returning to step 3 until all data input is completed for this program.	
8	<b>To Exit this Program</b> Press <b># # CR.</b>	P46 ## P

REMOTE ADMINISTRATION AND MAINTENANCE PROCEDURES  
SECTION 100-816-600  
MARCH 1993

TABLE RM-AU  
PROGRAM 46-10 ~ 40  
TOLL RESTRICTION CLASS PARAMETERS

STEP	ACTION	DISPLAY/PRINTOUT
1	Enter Program Mode At the >MODE prompt, enter <b>P R O G CR.</b>	>MODE PROG P
2	Enter Program Number 46 Press <b>CR.</b>	P 46 P46
3	Refer to the System Record Sheet and enter the Toll Restriction class number (1 ~ 4). Then enter the number <b>0.</b> Example: Class 1, enter <b>1 0.</b>	P46 10
4	Refer to the System Record Sheet and enter the required button/LED number. Example: Button number 11, enter <b>1 1.</b> The system will display the status of the button/LED.	P46 10 11 TABLE 1N
5	Refer to the System Record Sheet and change if required (Y or N). To access next button number, press <b>SPACE.</b>	P46 10 11 TABLE1 N Y 12 TABLE2 N
6	To Exit Program/Store Data A) To store data, press <b>CR.</b> B) To exit this program, press <b># # CR.</b>	P46 10 11 TABLE1 N Y 12 TABLE2 N P46 ## P

**TABLE RM-AV  
PROGRAM 47  
TOLL RESTRICTION EXCEPTION OFFICE CODES ASSIGNED BY AREA CODE**

STEP	ACTION	DISPLAY/PRINTOUT
1	<b>Enter Program Mode</b> At the >MODE prompt, enter <b>P R O G CR</b> .	>MODE PROG P
2	<b>Enter Program Number 47</b> Press <b>CR</b> .	P 47 P47
3	Enter exception table (1 ~ 8) and press <b>1</b> .	P47 Y 1 AREA CODE NNN
4	Refer to the System Record Sheet and enter the required area code and press <b>CR</b> . Example: AC 714, enter <b>7 1 4 CR</b> .	P47 Y 1 AREA CODE NNN 714 P47
5a	<b>To Add Exception Office Codes to Table</b> <ul style="list-style-type: none"> <li>• Enter exception table (1 ~ 8) and press <b>2</b>.</li> <li>• Enter exception codes <input type="text"/> <input type="text"/> <input type="text"/> or <input type="text"/> <input type="text"/> * <input type="text"/> <input type="text"/> .</li> <li>• Press <b>SPACE</b> to add more codes.</li> <li>• Press <b>SPACE CR</b> to store codes.</li> </ul>	P47 <input type="text"/> <b>2</b>  Except  Except <input type="text"/> <input type="text"/> <input type="text"/>
5b	<b>To Delete Exception Office Codes from Table</b> <ul style="list-style-type: none"> <li>• Enter exception table (1 ~ 8) and press <b>3</b>.</li> <li>• Enter exception codes <input type="text"/> <input type="text"/> <input type="text"/> or <input type="text"/> <input type="text"/> * <input type="text"/> <input type="text"/> .</li> <li>• Press <b>SPACE</b> to delete more codes.</li> <li>• Press <b>SPACE CR</b> to store codes.</li> </ul>	P47 <input type="text"/> <b>3</b>  Delete  Delete <input type="text"/> <input type="text"/> <input type="text"/>
5c	<b>To Display Exception Office Codes in Table</b> <ul style="list-style-type: none"> <li>• Enter exception table (1 ~ 8) and press <b>4 SPACE</b>.</li> <li>• Press <b>SPACE</b> to display more codes.</li> <li>• Press <b>CR</b> to exit display.</li> </ul>	P47 <input type="text"/> <b>4</b>  Except <input type="text"/> <input type="text"/> <input type="text"/>
6	<b>To Exit Program/Store Data: # # CR</b> .	P47 Y 2 Except <input type="text"/> <input type="text"/> <input type="text"/> P47 ## P

TABLE RM-AW  
PROGRAM 48  
STATION TOLL RESTRICTION CLASSIFICATION

STEP	ACTION	DISPLAY/PRINTOUT
1	<b>Enter the Program Mode</b> At the >MODE prompt, enter <b>P R O G CR.</b>	>MODE PROG P
2	<b>Enter Program Number 48</b> Press <b>CR.</b>	P 48 P48
3	Refer to the System Record Sheet and enter the required port number. Example: Port 00, enter <b>0 0.</b>	P48 00
4	Press <b>#</b> key. The system will display the present data as a two-digit code: The first digit designates digit free or digit restrict. The second digit is the station restriction code. Refer to the System Record Sheet and change if required.	P48 00# 13
5	<b>To Exit Program/Store Data</b> A) To store data, press <b>CR.</b> B) Continue returning to step 3 until all data is recorded for this program. C) To exit this program, press <b># # CR.</b>	P48 00# 13 P48 ## P

TABLE RM-AX  
PROGRAM 50-1  
LCR PARAMETERS

STEP	ACTION	DISPLAY/PRINTOUT
1	<b>Enter Program Mode</b> At the >MODE prompt, enter <b>P R O G CR.</b>	>MODE PROG P
2	<b>Enter Program Number 50.</b> Press <b>CR.</b>	P 50 P50
3	Enter <b>1.</b> Refer to the System Record Sheet and enter the required button/LED number. Example: Button 01, enter <b>0 1.</b>	P50 1 01 N
4	Refer to the System Record Sheet and change button/LED status, if required. Press <b>SPACE</b> to move to next button/LED.	P50 1 01 N 02 N
5	<b>To Exit Program/Store Data</b> A) To store data, press <b>CR.</b> B) To exit this program, press <b># # CR.</b>	P50 1 01 N 02 N P50 ## P

**TABLE RM-AY  
PROGRAM 50-2  
LCR HOME AREA CODE**

STEP	ACTION	DISPLAY/PRINTOUT
1	<b>Enter Program Mode</b> At the >MODE prompt, enter <b>P R O G CR.</b>	>MODE PROG P
2	<b>Enter Program Number 50</b> Press <b>CR.</b>	P 50 P50
3	Enter the number <b>2</b> . The system will display the last area code programmed. Refer to the System Record Sheet and change if required.	P50 2 NNN
4	<b>To Exit Program/Store Data</b> A) To store data, press <b>CR.</b> B) To exit this program, press <b># # CR.</b>	P50 2 NNN P50 ## P

**TABLE RM-AZ  
PROGRAM 50-31 ~ 35  
LCR SPECIAL CODES**

STEP	ACTION	DISPLAY/PRINTOUT
1	<b>Enter Program Mode</b> At the >MODE prompt, enter <b>P R O G CR.</b>	>MODE PROG P
2	<b>Enter Program Number 50</b> Press <b>CR.</b>	P 50 P50
3	Refer to the System Record Sheet and enter 31 ~ 35 as required. Example: 31, enter <b>3 1</b> . System will display previously programmed number. Refer to the System Record Sheet and change if required.	P50 31 NNNN
4	<b>To Exit Program/Store Data</b> A) To store data, press <b>CR.</b> B) Continue returning to step 3 until all data for this program has been entered. C) To exit this program, press <b># # CR.</b>	P50 31 NNNN P50 ## P

REMOTE ADMINISTRATION AND MAINTENANCE PROCEDURES  
SECTION 100-816-600  
MARCH 1993

TABLE RM-BA  
PROGRAM 50-4  
LCR LDI PLAN NUMBER

STEP	ACTION	DISPLAY/PRINTOUT
1	<b>Enter Program Mode</b> At the >MODE prompt, enter <b>P R O G CR.</b>	>MODE PROG P
2	<b>Enter Program Number 50</b> Press <b>CR.</b>	P 50 P50
3	<b>Enter the number 4</b> The system will display the present LDI route number. Refer to the System Record Sheet and change if required.	P50 4 1
4	<b>Exit Program/Store Data</b> A) To store data, press <b>CR.</b> B) To exit this program, press <b># # CR.</b>	P50 4 1 P50 ## P

TABLE RM-BB  
PROGRAM 50-5  
LCR LOCAL CALL PLAN NUMBER

STEP	ACTION	DISPLAY/PRINTOUT
1	<b>Enter Program Mode</b> At the >MODE prompt, enter <b>P R O G CR.</b>	>MODE PROG P
2	<b>Enter Program Number 50</b> Press <b>CR.</b>	P 50 P50
3	<b>Enter the number 5</b> The system will display the present local route plan number. Refer to the System Record Sheet and change if required. Example: 2, enter <b>2.</b>	P50 5 1 2
4	<b>Exit Program/Store Data</b> A) To store data, press <b>CR.</b> B) To exit this program, press <b># # CR.</b>	P50 5 1 2 P50 ## P

**TABLE RM-BC  
PROGRAM 50-6  
LCR DIAL ZERO TIMEOUT**

STEP	ACTION	DISPLAY/PRINTOUT
1	<b>Enter Program Mode</b> At the >MODE prompt, enter <b>P R O G CR.</b>	>MODE PROG P
2	<b>Enter Program Number 50</b> Press <b>CR.</b>	P 50 P50
3	<b>Enter the number 6</b> The system will display the present dial zero timeout. Refer to the System Record Sheet and change if required. Example: 10, enter <b>1 0.</b>	P50 6 06 10
4	<b>Exit Program/Store Data</b> A) To store data, press <b>CR.</b> B) To exit this program, press <b># # CR.</b>	P50 6 06 10 P50 ## P

**TABLE RM-BD  
PROGRAM 51  
LCR AREA CODES**

STEP	ACTION	DISPLAY/PRINTOUT
1	<b>Enter Program Mode</b> At the >MODE prompt, enter <b>P R O G CR.</b>	>MODE PROG P
2	<b>Enter Program Number 51</b> Press <b>CR.</b>	P 51 P51
3	Refer to the System Record Sheet and enter the required route plan number (1 ~ 8). Example: Route plan 1, enter <b>1.</b>	P51 1
4	Enter <b>2, 3, or 4 SPACE</b> • <b>2</b> — To add area codes to table. • <b>3</b> — To delete area codes from table. • <b>4 SPACE</b> — to display area codes in table, continue to press <b>SPACE</b> to display more codes. Press <b>CR</b> to exit display.	P51 <input type="text"/> <input type="text"/> — 2, 3 or 4 └── Plan No.  P51 <input type="text"/> <input type="text"/>  <input type="text"/> <input type="text"/> ← CODES
5	Enter codes <input type="text"/> <input type="text"/> <input type="text"/> or <input type="text"/> <input type="text"/> <input type="text"/> * <input type="text"/> <input type="text"/> <input type="text"/> and press <b>SPACE</b> after each code entry.	P51 <input type="text"/> <input type="text"/> <input type="text"/> <input type="text"/> <input type="text"/> <input type="text"/>
6	<b>Exit Program/Store Data</b> A) To store data, press <b>CR.</b> B) Continue returning to step 3 until all data has been entered for this program. C) To exit this program, press <b># # CR.</b>	P51 12 212 or <input type="text"/> <input type="text"/> <input type="text"/> - <input type="text"/> <input type="text"/> P51 ## P





TABLE RM-BF  
PROGRAM 53  
LCR SCHEDULE ASSIGNMENT

STEP	ACTION	DISPLAY/PRINTOUT
1	<b>Enter Program Mode</b> At the >MODE prompt, enter <b>P R O G C R</b> .	>MODE PROG P
2	<b>Enter Program Number 53</b> Press <b>CR</b> .	P 53 P53
3	<b>Define Route Plan Number</b> Refer to the System Record Sheet and enter the route plan number (1 ~ 8). Example: Route Plan 1, enter <b>1</b> .	P53 1
4	<b>Define Schedule Number</b> Refer to the System Record Sheet and enter the required schedule number (1 ~ 3). Example: Schedule 1, enter <b>1</b> .	P53 11
5	<b>Enter Code Number 0</b> The system will display the previously selected time for the route plan number (step 3) and the schedule number (step 4). Refer to the System Record Sheet and change the time if required. Example: Change to 0800. Enter <b>0 8 0 0</b> . Press <b>CR</b> and repeat steps 3, 4, and 5 for all plans/schedules. <i>NOTE: Enter time using 24-hour format: H H M M.</i>	P53 110 0000 0800 P53
6	<b>Priority Class Assignment</b> Enter the route plan number as defined in step 3. Enter the schedule number as defined in step 4. Refer to the System Record Sheet and enter the required station group number (1 ~ 4). Example: Group 1, enter <b>1</b> . The system will display the previously entered route definition numbers (reference <b>Program 54</b> ). Refer to the System Record Sheet and enter required route definition numbers (1 ~ 4) and press <b>CR</b> . Example: Enter <b>1</b> and <b>2 CR</b> . Continue to repeat steps 3, 4, and 6 until all plans/schedules are entered.	P53 111 NNNN 12 P53
7	<b>To Exit Program/Store Data</b> A) Data was stored when pressing <b>CR</b> in step 6. B) Continue returning to step 3 until all data is entered for this program. C) To exit this program. Press <b># # CR</b> .	P53 ## P

TABLE RM-BG  
PROGRAM 54  
LCR ROUTE DEFINITION

STEP	ACTION	DISPLAY/PRINTOUT
1	<p><b>Enter Program Mode</b>  At the &gt;MODE prompt, enter <b>PROG CR</b>.</p>	<p>&gt;MODE PROG  P</p>
2	<p><b>Enter Program Number 54</b>  Press <b>CR</b>.</p>	<p>P 54  P54</p>
3	<p><b>Enter Route Plan Number</b>  Refer to the System Record Sheet and enter the required route plan number (1 ~ 8).  Example: Route plan 1, enter <b>1</b>.</p>	<p>P54 1</p>
4	<p><b>Enter Route Definition Number</b>  Refer to the System Record Sheet and enter the required route definition number (1 ~ 4).  Example: Enter route definition number 2, enter <b>2</b>.  The system will display the previously entered CO line group number (1 ~ 8) and the modified digits table number (1 ~ 6).  Refer to the System Record Sheet and enter the CO line group and modified digit numbers as required, then press <b>CR</b>.  Example: Change the CO line group number to 3 and the modified digits table to 2. Enter: <b>3 2 CR</b>.</p>	<p>P54 12 11 32</p> <p>Modified Digit Table No.  CO Line Group No.  Route Definition No.  Plan No.</p>
5	<p><b>To Exit Program/Store Data</b>  A) To store data, press <b>CR</b>.  B) Continue returning to step 3 until all data has been entered for this program.  C) To exit this program, press <b>## CR</b>.</p>	<p>P54 12 11 32  P54 ##  P</p>

TABLE RM-BH  
PROGRAM 55-0  
LCR MODIFIED DIGITS-DELETE

STEP	ACTION	DISPLAY/PRINTOUT
1	<b>Enter Program Mode</b> At the >MODE prompt, enter <b>P R O G CR.</b>	>MODE PROG P
2	<b>Enter Program Number 55</b> Press <b>CR.</b>	P 55 P55
3	<b>Enter Modified Digits Table Number</b> Refer to the System Record Sheet and enter the modified digits table number (1 ~ 6). Example: Enter modified digits table number 1, enter <b>1.</b>	P55 1
4	<b>Enter Code 0</b> The system will display any previously entered number of digits to be deleted (01 ~ 10). Refer to the System Record Sheet and change number if required. Example: Change to 10, enter: <b>1 0.</b>	P55 10 05 10
5	<b>To Exit Program/Store Data</b> A) To store data, press <b>CR.</b> B) Continue returning to step 3 until all data has been entered for this program. C) To exit this program, press <b># # CR.</b>	P55 10 05 10 P55 ## P

TABLE RM-BI  
PROGRAM 55-1  
LCR MODIFIED DIGITS-ADD

STEP	ACTION	DISPLAY/PRINTOUT
1	<p><b>Enter Program Mode</b>  At the &gt;MODE prompt, enter <b>P R O G CR.</b></p>	<p>&gt;MODE PROG  P</p>
2	<p><b>Enter Program Number 55</b>  Press <b>CR.</b></p>	<p>P 55  P55</p>
3	<p><b>Enter Modified Digits Table Number</b>  Refer to the System Record Sheet and enter the required modified digits table number (1 ~ 6).  Example: Enter table number 1, enter <b>1.</b></p>	<p>P55 1</p>
4	<p><b>Enter Code 1</b>  The system will display any previously entered digits (up to 22). Refer to the System Record Sheet and enter new numbers, if required.  Example: Enter <b>1 2 3 4 P 3.</b>  NOTE: <i>Pause codes may also be entered. To enter pauses, press "P" plus the pause number (1 ~ 8).</i>  Special Code Input  Pause = <b>P 1 ~ P 8.</b>  Tone = <b>T</b> at beginning of digits to convert.  Clear = <b>C</b> as first digit, then <b>CR.</b></p>	<p>P55 11 <input type="text"/> <input type="text"/> <input type="text"/> (up to 22 digits)  1 2 3 4 P3</p>
5	<p><b>To Exit Program/Store Data</b>  A) To store data, press <b>CR.</b>  B) Continue returning to step 3 until all data has been entered for this program.  C) To exit this program, press <b># # CR.</b></p>	<p>P55 11 <input type="text"/> <input type="text"/> <input type="text"/>  1 2 3 4 P3  P55 ##  P</p>

**TABLE RM-BJ  
PROGRAM 55-2  
LCR MODIFIED DIGITS-END**

STEP	ACTION	DISPLAY/PRINTOUT
1	<b>Enter Program Mode</b> At the >MODE prompt, enter <b>P R O G CR</b> .	>MODE PROG P
2	<b>Enter Program Number 55</b> Press <b>CR</b> .	P 55 P55
3	<b>Enter Modified Digits Table Number</b> Refer to the System Record Sheet and enter the required modified digits table number (1 ~ 6). Example: Enter table number 1, enter <b>1</b> .	P55 1
4	<b>Enter Code 2</b> The system will display any previously entered digits (up to 22). Refer to the System Record Sheet and enter new numbers, if required. Example: Enter <b>1 2 3 4 P 3</b> . <i>NOTE: Pause codes may also be entered. To enter pauses, press "P" plus the pause number (1 ~ 8).</i> Special Code Input Pause = <b>P 1 ~ P 8</b> . Tone = <b>T</b> at beginning of digits to convert. Clear = <b>C</b> as first digit, then <b>CR</b> .	P55 12 <input type="text"/> <input type="text"/> <input type="text"/> <input type="text"/> (up to 22 digits) 1 2 3 4 P3
5	<b>To Exit Program/Store Data</b> A) To store data, press <b>CR</b> . B) Continue returning to step 3 until all data has been entered for this program. C) To exit this program, press <b># # CR</b> .	P55 12 <input type="text"/> <input type="text"/> <input type="text"/> <input type="text"/> (up to 22 digits) 1 2 3 4 P3 P55 ## P

REMOTE ADMINISTRATION AND MAINTENANCE PROCEDURES  
SECTION 100-816-600  
MARCH 1993

TABLE RM-BK  
PROGRAM 56  
LCR STATION GROUP ASSIGNMENT

STEP	ACTION	DISPLAY/PRINTOUT
1	<b>Enter Program Mode</b> At the >MODE prompt, enter <b>P R O G CR.</b>	>MODE PROG P
2	<b>Enter Program Number 56</b> Press <b>CR.</b>	P 56 P56
3	<b>Enter Port Number</b> Refer to the System Record Sheet and enter the required port number, <input type="checkbox"/> <input type="checkbox"/> or <input type="checkbox"/> <input type="checkbox"/> * <input type="checkbox"/> <input type="checkbox"/> . Example: Port 01, enter <b>0 1.</b>	P56 01
4	<b>Press # Key</b> (if single port <input type="checkbox"/> <input type="checkbox"/> entry in step 3). The system will display any previously entered group number (1 ~ 4). Refer to the System Record Sheet and change as required. Example: Change to 4, enter <b>4.</b>	P56 01# 1 4
5	<b>To Exit Program/Store Data</b> A) To store data, press <b>CR.</b> B) Continue returning to step 3 until all data has been entered for this program. C) To exit this program, press <b># # CR.</b>	P56 01# 1 4 P56 ## P

TABLE RM-BL  
PROGRAM DATA DUMP

STEP	ACTION	DISPLAY/PRINTOUT
1	<b>Enter the Data Dump Mode</b> At the >MODE prompt, enter <b>D U M P CR.</b>	>MODE DUMP D
2	<b>To Output Program Data</b> Enter <b>P R G <input type="checkbox"/><input type="checkbox"/> CR</b> <input type="checkbox"/> <input type="checkbox"/> = Program number or <b>A L L</b> for all programs.	D PROG <input type="checkbox"/> <input type="checkbox"/>
3	<b>To Stop Printout at Any Time</b> Enter <b>DELETE CR</b> at the same time.	D
4	<b>To Exit the Dump Mode</b> Enter <b>Q U I T CR.</b>	>MODE

**TABLE RM-BM  
SPEED DIALING DATA DUMP**

STEP	ACTION	DISPLAY/PRINTOUT
1	Enter the Data Dump Mode At the >MODE prompt, enter <b>D U M P CR.</b>	>MODE DUMP D
2	To Output Speed Dialing Data Enter <b>REP [ ][ ] CR</b> ---or--- <b>REP [ ] CR</b> [ ][ ] = <b>A L L</b> or <b>S Y S</b> [ ] = Port number for individual station speed dial.	
3	To Stop Printout at Any Time Enter <b>DELETE CR</b> at the same time.	D
4	To Exit the Dump Mode Enter <b>Q U I T CR.</b>	

**TABLE RM-BN  
LCD MESSAGING DATA DUMP**

STEP	ACTION	DISPLAY/PRINTOUT
1	Enter the Data Dump Mode At the >MODE prompt, enter <b>D U M P CR.</b>	>MODE DUMP
2	To Output Message Data Enter <b>MSG [ ][ ] CR</b> ---or--- <b>MSG [ ] CR</b> [ ][ ] = <b>A L L</b> or <b>S Y S</b> [ ] = Port number of individual station.	D MSG [ ][ ]
3	To Stop Printout at Any Time Enter <b>DELETE CR</b> at the same time.	D
4	To Exit the Dump Mode Enter <b>Q U I T CR.</b>	>MODE



TABLE RM-B0  
MODE 95  
REMOTE CALLING STATION MESSAGING (ADD/REVIEW/CHANGE)

STEP	ACTION	DISPLAY/PRINTOUT
1	<b>Enter the Message Mode</b> At the >MODE prompt, enter <b>M E S G C R</b> .	>MODE MSG
2	<b>To Add Or Review a Calling Station Message</b> Set the terminal keyboard to the lower case (cap lock off) and enter <b>m 9 5</b> .  <i>NOTE:</i> Enter "m" anytime it is desired to start over in this procedure.	m 95
3	Enter <b>X X X</b> (XXX = station number where the message will be set and stored).	m95 XXX
4	Enter <b>p</b> <input type="text"/> <input type="text"/> (p = page command and <input type="text"/> <input type="text"/> = 2-digit message memory location: 10 ~ 19 personal messages and 60 ~ 99 = system message).  <i>NOTES:</i> 1. To store system messages permanently, DKT or EKT XXX must be the station at port 00. 2. After <b>p</b> <input type="text"/> <input type="text"/> is entered, the previously stored message is displayed. If there is no stored message, nothing is displayed.	m95 XXX p <input type="text"/> <input type="text"/> [M]
5	<b>To Change Previous Message</b> Set the terminal keyboard to upper case and change message (alphanumeric, 32 characters max.).	m95 XXX p <input type="text"/> <input type="text"/> [M+]
6	<b>To Set the Message on DKT or EKT XXX's LCD</b> Set the terminal keyboard to lower case and enter <b>p m 0</b> .	m95 XXX p <input type="text"/> <input type="text"/> [M+] p m 0 └ Zero
7	<b>To Exit the Message Mode</b> At any time, enter <b>m 0 q</b> (lower case).	m 0 q > MODE

*NOTES:*

1. To cancel a message set via Mode 95, use Mode 97 procedure.
2. [M] represents the message entered.
3. DKT = digital telephone; EKT = electronic telephone.

**TABLE RM-BP  
MODE 97  
REMOTE CALLING STATION MESSAGING (ADD/CHANGE)**

STEP	ACTION	DISPLAY/PRINTOUT
1	<b>Enter the Message Mode</b> At the >MODE prompt, enter <b>M E S G CR.</b>	>MODE MESSG
2	<b>To Add a Message</b> (or change a previously stored message) Set the terminal keyboard to lower case (caps lock off) and enter <b>m 9 7.</b>  <i>NOTE:</i> <i>Enter "m" at anytime it is desired to start over in this procedure.</i>	m 97
3	Enter <b>X X X</b> (XXX = station number for which the message will be set and stored).	m97 XXX
4	Enter: <b>p</b> <input type="checkbox"/> <input type="checkbox"/> (p = page command and <input type="checkbox"/> <input type="checkbox"/> = 2-digit message memory location: 10 ~ 19 personal messages and 60 ~ 99 = system messages).  <i>NOTE:</i> <i>To store system message change permanently, DKT or EKT XXX must be station assigned to port 00.</i>	m97 XXX p <input type="checkbox"/> <input type="checkbox"/>
5	<b>To Add a Message</b> Set the terminal keyboard to upper case and enter message (alphanumeric, 32 characters max.). New message displays as it is entered.	m97 XXX p <input type="checkbox"/> <input type="checkbox"/> [M]
6	<b>To Set the Message on the DKT/EKT LCD</b> Set the terminal keyboard to lower case and enter <b>p m 0.</b>	m97 XXX p <input type="checkbox"/> <input type="checkbox"/> [M] p m <u>0</u> Zero
7	<b>To Exit the Message Mode</b> At any time, enter <b>m 0 q</b> (lower case).	m 0 q >MODE

**NOTES:**

1. To cancel a message set via Mode 95, use Mode 97 with any message number in step 4 and skip step 5.
2. [M] represents the message entered.
3. DKT = digital telephone; EKT = electronic telephone.

REMOTE ADMINISTRATION AND MAINTENANCE PROCEDURES  
SECTION 100-816-600  
MARCH 1993

TABLE RM-BQ  
MODE 94  
REMOTE CALLED STATION MESSAGING (ADD/REVIEW/CHANGE)

STEP	ACTION	DISPLAY/PRINTOUT
1	<b>Enter the Message Mode</b> At the >MODE prompt, enter <b>M E S G CR</b> .	>MODE MESSG
2	<b>To Add Or Review a Called Station Message</b> Set the terminal keyboard to the lower case (cap lock off) and enter <b>m 9 4</b> .	m 94
3	Enter <b>X X X</b> (XXX = Destination station number or destination group number [30 = all stations, 31-34 per system, <b>Program 31</b> ]).	m94 XXX
4	Enter <b>p Y Y Y</b> (p = page command [lower case] and <b>Y Y Y</b> = originating station number).	m94 XXX p YYY
5	Enter <b>p □□</b> (p = page command [lower case] and □□ = 2-digit message memory location: 10 ~ 19 personal messages and 60 ~ 99 = system messages). After <b>p □□</b> is entered, the previously stored message (M) is displayed. (If there is no stored message, nothing is displayed.)	m94 XXX p YYY p □□ [M]
6	<b>To Change the Message (M+)</b> Set the terminal keyboard to upper case and change message as required (alphanumeric, 32 characters max. for total message).	m94 XXX p YYY p □□ [M+]
7	<b>To Set Message</b> Set the terminal keyboard to lower case and enter <b>p m 0</b> . Destination station: Msg LED flashes, "CALL YYYYM" is displayed. Origination station: "SENT XXXM" is displayed.	m94 XXX p YYY p □□ [M+] p m 0 Zero
8	<b>To Exit the Message Mode</b> At any time, enter <b>m 0 q</b> (lower case).	m 0 q >MODE

NOTES:

1. Press **m** at any time to start over.
2. [M] represents the message entered.

**TABLE RM-BR  
MODE 96  
REMOTE CALLED STATION MESSAGING (ADD/CHANGE)**

STEP	ACTION	DISPLAY/PRINTOUT
1	<b>Enter the Message Mode</b> At the >MODE prompt, enter <b>M E S G CR</b> .	>MODE MESSG
2	<b>To Change or Add a New Called Station Message</b> Set the terminal keyboard to the lower case (cap lock off) and enter <b>m 9 6</b> .  <i>NOTE:</i> <i>Enter "m" (lower case) anytime it is desired to start over in this procedure.</i>	m 96
3	Enter <b>X X X</b> (XXX = destination station number or destination station group number – 30 = all DKTs/EKTs, 31 ~ 34 per system, <b>Program 31</b> ).	m96 XXX
4	Enter <b>p Y Y Y</b> (p = page command and YYY = originating station number).	m96 XXX p YYY
5	Enter <b>p □ □</b> (p = page command and □ □ = 2-digit message memory location: 10 ~ 19 personal messages and 60 ~ 99 = system messages).	m96 XXX p YYY p □ □
6	<b>To Add the New Message [M]</b> Set the terminal keyboard to upper case and enter message as required (alphanumeric, 32 characters max.). New message displays as it is entered.	m96 XXX p YYY p □ □ [M]
7	<b>To Set the Message</b> Set the terminal keyboard to lower case and enter <b>p m 0</b> . Destination station: Msg LED flashes, "CALL YYYYM" is displayed on LCD. Origination station: "SENT XXXM" is displayed on LCD.	m96 XXX p YYY p □ □ [M] p m 0 └ Zero
8	<b>To Exit the Message Mode</b> At any time, enter <b>m 0 p</b> (lower case).	m 0 q >MODE

**NOTES:**

1. [M] represents the message entered.
2. DKT = digital telephone; EKT = electronic telephone.

TABLE RM-BS  
STATION/CO LINE STATUS CHECK

STEP	ACTION	DISPLAY/PRINTOUT
1	Enter the Test Mode At the >MODE prompt, enter <b>T E S T CR.</b>	>MODE TEST
2	To Check Station Line Status Enter <b>S E K T X X</b> (X X = port number). Possible status: Idle on-hook, idle off-hook, busy on-hook, busy off-hook.  <b>IMPORTANT!</b> <i>To prevent service interference, station line status must be idle on-hook before initiating a test from that station.</i>	T SEKT XX IDLE ON-HOOK T
3	To Check CO Line Status Enter <b>S C O Y Y</b> (Y Y = CO line number). Possible status: Idle, busy.	T SCOYY - BUSY T
4	To Exit the Test Mode At the T prompt, enter <b>Q U I T CR.</b>	T QUIT > MODE

TABLE RM-BT  
GENERAL STATION ACCESS AND BUTTON ACTIVATION

STEP	ACTION	DISPLAY/PRINTOUT								
1	Enter the Test Mode At the >MODE prompt, enter <b>T E S T CR.</b>	>MODE TEST T								
2	To Activate A Button Enter <b>T K X X K Y Y CR.</b> XX = Port number and YY = button number. <i>NOTE: Button numbers begin at 01.</i>	T TKXX KYY T								
3	To Activate A Function Button Enter <b>T K X X F CR</b> F = function button designator <table border="1" style="display: inline-table; vertical-align: middle;"> <tr><td>SPKR</td><td>S</td></tr> <tr><td>HOLD</td><td>H</td></tr> <tr><td>CONF</td><td>C</td></tr> <tr><td>MIC</td><td>M</td></tr> </table> } F = S, H, C, M	SPKR	S	HOLD	H	CONF	C	MIC	M	TTKXX F T
SPKR	S									
HOLD	H									
CONF	C									
MIC	M									
4	To Access A CO Line (via CO Access Code) and Dial Out Enter <b>T K X X K 0 1 A A A</b> <input type="text"/> <input type="text"/> <input type="text"/> <input type="text"/> <input type="text"/> <input type="text"/> <b>CR.</b> AAA = 1, 2, or 3-digit CO line access code and = telephone number.	TTKXX K01 AAA <input type="text"/> <input type="text"/> <input type="text"/> <input type="text"/> <input type="text"/> <input type="text"/> T								
5	To Access A CO Line (via CO Line Button) and Dial Out Enter <b>T K X X K Y Y</b> <input type="text"/> <input type="text"/> <input type="text"/> <input type="text"/> <input type="text"/> <input type="text"/> <b>CR.</b> YY = CO line number. Telephone Number	TTKXX KYY <input type="text"/> <input type="text"/> <input type="text"/> <input type="text"/> <input type="text"/> <input type="text"/> T								
6	To Exit the Test Mode At T prompt, enter <b>Q U I T CR.</b>									

**TABLE RM-BU  
CO LINE TEST**

STEP	ACTION	DISPLAY/PRINTOUT
1	Enter the Test Mode At the >MODE prompt, enter <b>T E S T C R.</b>	>MODE TEST
2	<b>To Verify Station/CO Line Status</b> Station line status, enter <b>S E K T X X</b> (X X = station port). CO line status, enter <b>S C O Y Y</b> (Y Y = CO line number).	T SEKT XX IDLE ON-HOOK T T SCO YY IDLE
3	<b>Call Remote Station B</b> (from SEKT XX and CO line YY) Enter <b>T K X X K Y Y</b> □□□□□□ <b>C R.</b> (□ = station B's telephone number) Answer station B.  <i>NOTE:</i> <i>If the system is equipped with Music-on-hold, go to step 4. If the line must be tested via a CO-to-CO connection, go to step 6.</i>	T TK XX KY Y □□□□□□ T
4	A) Press the <b>Hold</b> button on TK XX (station B on hold). Enter <b>T K X X H C R.</b> B) Listen at station B and check that the transmission from the music source is acceptable. C) Press the <b>Spkr</b> button on TKXX (to release the call). Enter <b>T K X X S C R.</b>	T TKXX H T  T TKXX S T
5	Continue returning to step 2 until all CO lines are tested.	
6	<b>To Set Up A CO-to-CO Connection</b> Press the <b>Cnf/Trn</b> button on <b>T K X X</b> . Enter <b>T K X X C C R.</b>  <i>NOTES:</i> <i>1. Station B is connected via step 3.</i> <i>2. Verify that <b>Program 15-5</b> allows CO-to-CO connections.</i> <i>3. The next step must be completed immediately to avoid dial tone timeout.</i>	T TKXX C T
7	Call station C (or local time/weather) via CO line C. Enter: <b>T K X X K Y Y</b> □□□□□□ <b>C R.</b> <b>X X</b> = CO line C's button number and □ = telephone number of station C. Answer station C (or verify time/weather connection) and go to next step.	T TKXX KY Y □□□□□□ T
8	Press the <b>Cnf/Trn</b> button on STXX to establish a conference between all parties.	T TKXX C T
9	If you wish to tie the two CO lines together and hang up: Enter <b>T K X X C C R.</b> Enter <b>T K X X S C R.</b>	T TKXX C TTKXX S T
10	Continue returning to step 2 until all CO lines are tested.	
11	<b>To Exit the Test Mode,</b> At the T prompt, enter <b>Q U I T C R.</b>	

TABLE RM-BV  
SYSTEM DATE/DAY/TIME SETTING PROCEDURE

STEP	ACTION	DISPLAY/PRINTOUT
1	<b>Enter the Test Mode</b> At the >MODE prompt, enter <b>TEST CR.</b>	>MODE TEST T
2	<b>To Set Date</b> Enter <b>TK00K01651YYMMDD# CR.</b>	T TK00 K01 651YYMMDD# T
3	<b>To Set Time Of Day</b> Enter <b>TK00K01652HHMMSS# CR.</b>	TTK00 K01 652HHMMSS#
4	<b>To Set Day Of The Week</b> Enter <b>TK00K01653D# CR.</b> (D = day of week with Sunday = 1 ~ Saturday = 7)	TTK00 K01 653D# T
5	<b>To Exit the Test Mode</b> At T prompt, enter <b>QUIT CR.</b>	

TABLE RM-BW  
SPEED DIAL MODE (CHANGE/REVIEW)

STEP	ACTION	DISPLAY/PRINTOUT
1	<p><b>Enter the Speed Dial Mode</b> At the &gt;MODE prompt, enter <b>R E P T CR</b>.</p>	>MODE REPT
2	<p><b>Enter the station port number for which the speed dial number will be programmed</b> Press <input type="text"/> <input type="text"/>           └── (00 ~ 19)</p> <p><i>NOTE: If programming system speed dial, enter port number 00.</i></p>	<p>R <input type="text"/> <input type="text"/>     └── Station Port Number</p>
3	<p><b>Enter Speed Dial Memory Location to be Programmed</b> A) Press <input type="text"/> <input type="text"/> (current memory will display)           └── 10 ~ 49 Station               60 ~ 99 System</p> <p>B) Press <b>SPACE</b> to review each memory location or go to Step 4.</p>	<p>R <input type="text"/> <input type="text"/> <input type="text"/> N           └── Memory location   └── Nothing in memory</p>
4	<p><b>1) To enter speed dial number (20 digits max)</b> Press <input type="text"/> <input type="text"/> ..... <input type="text"/> <input type="text"/>           └── 20-digit number</p> <p><b>2) To enter chain dial number</b> Press <b>A</b> <input type="text"/> <input type="text"/> <input type="text"/> ..... <input type="text"/> <input type="text"/>           └── 17-digit number               └── System speed dial location (90 ~ 99)</p> <p>(Refer to Digital or Electronic Telephone User Guide for information regarding chain dialing.)</p> <p>Special Entries: F=Flash; P=1.5 or 3-sec Pause (Prog. 12);                   L=10-sec Pause; N=Clear Memory.</p> <p>Special code entry: I = Intercom                       H = Hold                       C = Conference</p>	<p>R <input type="text"/> <input type="text"/> <input type="text"/> N                           <input type="text"/> <input type="text"/> ..... <input type="text"/> <input type="text"/>                                   └── New speed dial number</p>
5	<p><b>To store data, press CR</b></p> <p><i>NOTE: If program entry is not correct, CR will not respond. To try again, press DELETE CR at the same time.</i></p>	R
6	<p><b>To Exit the Speed Dial Mode</b> Press <b>Q U I T CR</b>.</p>	>MODE







TB8-0001  
July 12, 1993

Page 1 of 12

## STRATA DK8 BUILT-IN AUTO ATTENDANT INSTALLATION INSTRUCTIONS

### DESCRIPTION

Auto Attendant\* operates like an automatic station attendant or switchboard operator that quickly and efficiently distributes calls to stations selected by callers. Incoming calls are greeted by an external announcement device that offers callers a menu of station locations associated with a number, such as 3 for Sales, 4 for Customer Service, etc. Callers pick the destination just by dialing the single number associated with it. The call is then transferred to the assigned station or hunt group.

*\*Licensed by Dytel under United States Patent No. 4,975,941*

### IMPORTANT NOTE!

***For Built-in Auto Attendant to work properly with Strata DK, Automatic Release (AR) must be sent by the calling Central Office. The existence of AR should be checked before selling to the end user. Check that the CO lines have AR enabled in Programs 15-0 and 15-3. Have an outside caller ring into the Strata system, then put the call on hold, and have the outside caller hang up. The line on hold should automatically hang up the line in a few seconds (typically, 3 ~ 15 seconds).***

### INSTALLATION REQUIREMENTS:

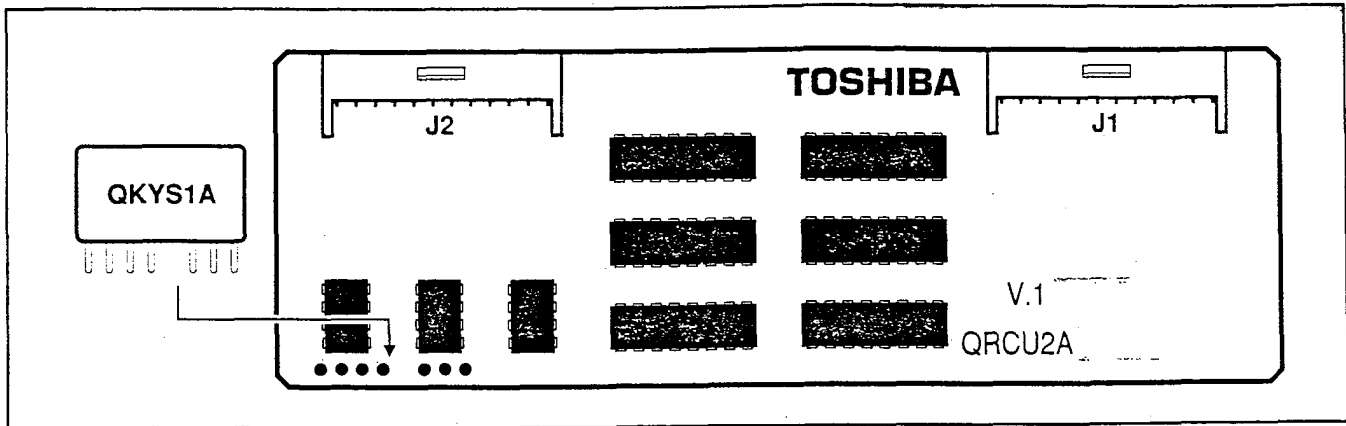
To enable the DK8 built-in Auto Attendant the system must be equipped with a QRCU2 (not QRCU1) PCB, QKYS1 feature key, and QSTU standard telephone interface PCB. The QCRU2 PCB accommodates Dual-tone Multi-Frequency (DTMF) and AutoBusy Redial (ABR) tone detection.

### IMPORTANT NOTE!

*The DK8 system Power switch must be OFF when installing QSTU1 and QRCU2.*

1. Install the QSTU per the instructions in Chapter 4 of the DK8 & DK16 *Installation and Maintenance Manual*. Connect Digital announcers to QSTU per Figure 3 of this Bulletin, and Chapter 8 of the DK8 & DK16 *Installation and Maintenance Manual*.

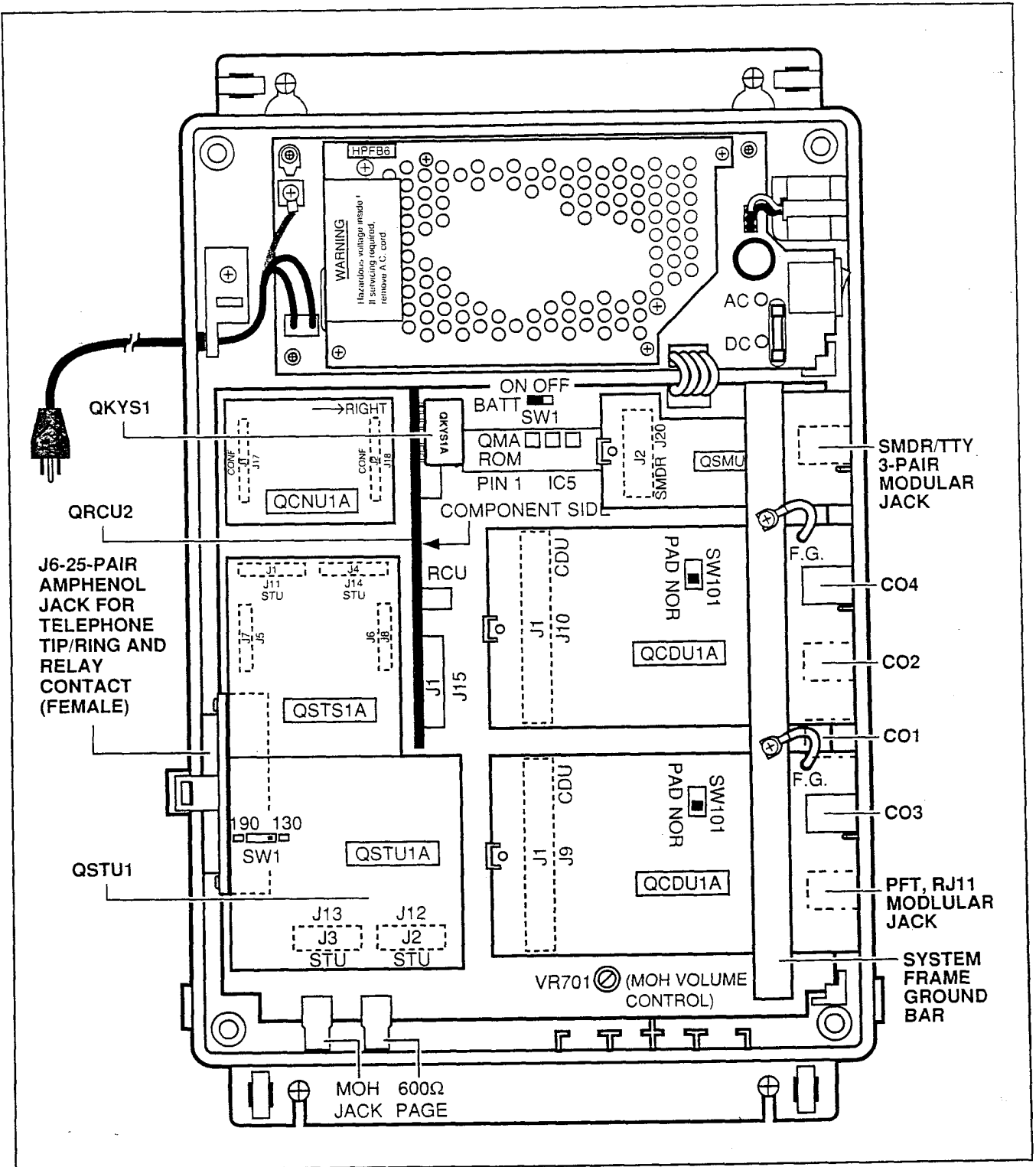
## STRATA DK8 BUILT-IN AUTO ATTENDANT INSTALLATION INSTRUCTIONS



**Figure 1**  
**QKYS1 INTERFACE CONNECTORS**

2. Install QRCU2 and QKYS1 per the following instructions:
  - a. Remove the QRCU2 and QKYS1 from packaging.
  - b. Install QKYS1 on QRCU2 per Figure 1.
  - c. Make sure that the DKSU8 power supply switch is OFF.
  - d. Align and insert QRCU2 connectors J1 and J2 into DKSU8 connectors J15 and J16 respectively (note the component side placement in Figure 2), and apply firm, even pressure to ensure proper mating of connectors. Push down until connectors lock together.
3. QRCU2/QKYS1 CONFIGURATION : DK8 QRCU2/QKYS1 does not require Program 03 assignments. The default settings for QRCU2 release time (Program 12) and After Flash operation (Program 15) are adequate for the built-in Auto Attendant application.
4. Program DK8 built-in Auto Attendant per the instructions that follow in this bulletin.

**STRATA DK8 BUILT-IN AUTO ATTENDANT INSTALLATION INSTRUCTIONS**



**Figure 2  
 DK8 PRINTED CIRCUIT BOARD INSTALLATION**

## STRATA DK8 BUILT-IN AUTO ATTENDANT INSTALLATION INSTRUCTIONS

### DIGITAL ANNOUNCERS

There are in general two types of digital announcers. The first type is like a home answering machine. Typically, it answers on the second or forth ring and plays the entire length of the announcement, regardless of whether the caller has hung up or not. This type will hereafter be referred to as Type I. An example of Type I is the AT&T Digital System 1337.

A professional digital announcer is another type. Typically, it answers on the first or third ring and plays only until the key system no longer needs announcements. Therefore, it recognizes that the built-in Auto Attendant no longer needs service when the loop is opened. This requires the announcer to disconnect when the QSTU opens the loop connected to the announcer for 100 milliseconds after the digits are dialed. Type II usually has better quality audio and an adjustment for playback volume. Type II digital announcers with improved performance typically cost two to three times as much as Type I. An example of Type II is the Interalia Voice series.

The number of digital announcers required relates to the length of the announcement message and the level of service required. Two digital announcers may be required to accommodate incoming calls if the announcement is particularly long. In most cases, one digital announcer for the primary announcement will suffice. Another one may be desired for secondary answering.\* In some instances, if the announcement is over 16 to 20 seconds long, Auto Attendant may be bypassed and the calling party will ring to preassigned CO ringing assignments. For this case, another Type I digital announcer on another port will reduce the ring-in time and the probability of not being serviced by Auto Attendant; or, a Type II announcer will reduce the ring time, particularly in a low traffic system.

*\*If using a secondary announcer, only one primary announcer can be used.*

### STRATA DK8 BUILT-IN AUTO ATTENDANT (AA) OVERVIEW

- A built-in Auto Attendant feature is included in the STRATA DK8 system software.
- To enable the built-in Auto Attendant to function, a QRCU2 (not QRCU1) DTMF tone receiver PCB and the QKRS1 Feature Key must be installed on the DK8 per Figures 1 and 2.
- The customer needs to provide digital announcement device(s) on which the greeting and menu that the callers hear are recorded.
- The digital announcement devices must connect to STRATA DK8 QSTU standard telephone circuits (maximum 2). Callers must use a DTMF (tone) telephone to select Auto Attendant dialing options.

The built-in Auto Attendant feature is very flexible. Calls to the built-in Auto Attendant follow the basic sequences described below and illustrated in Figure 4.

- **Sequence A.** The call is answered directly after being transferred from the Auto Attendant. The caller calls in on CO lines assigned for built-in Auto Attendant, receives a greeting along with a menu of dialing options, and then dials an option or the intercom number. The call is then transferred to a station, which answers the call.
- **Sequence B.** The call is not answered after being transferred from the Auto Attendant and is routed to an optional secondary announcement, where it will receive a new announcement and the same or additional dialing options. Some customers may not configure their Auto Attendant system with a secondary announcement; if so, their unanswered calls would follow sequence C or D.
- **Sequence C.** The call is not answered after being transferred from the Auto Attendant and is routed to an alternate station(s) assigned in system programming, ringing assignments.
- **Sequence D.** The call is not answered after being transferred from the Auto Attendant and is routed back to the primary announcement. This is probably the least desirable of the four sequences, since the caller hears a repeat of the announcement he just received seconds earlier.

DK8 built-in Auto Attendant does not support the following features which exist in DK280: Ringing Station(s) with Auto Attendant delayed answer, if ringing station(s) does not answer; or, Music-On-Hold to the caller when the Auto Attendant transfers a call. Also, flexible disconnect timer is not provided in DK8. The disconnect timer is fixed at 40 seconds for Ring No Answer if the outside caller does not dial digits.

### BUILT-IN AUTO ATTENDANT FLOW CHART

A detailed flow chart which includes call flow patterns and associated programs is provided in Figure 5.

## STRATA DK8 BUILT-IN AUTO ATTENDANT INSTALLATION INSTRUCTIONS

### INITIALIZATION PROGRAMMING (READ ALL STEPS BEFORE BEGINNING):

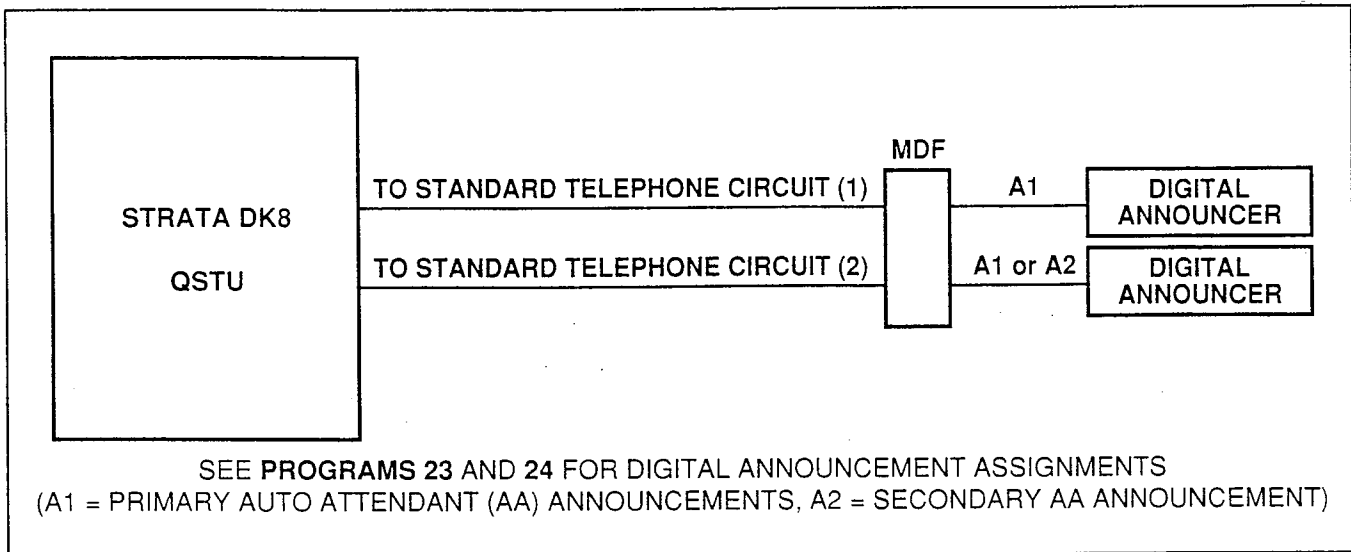
1. Existing installations do not require re-initialization after installing QCRU2, QKYS1, and QSTU.
2. All new DK8 installations require full initialization per the DK8 & DK16 *Installation & Maintenance Manual* prior to built-in Auto Attendant programming.

### BUILT-IN AUTO ATTENDANT PROGRAMMING

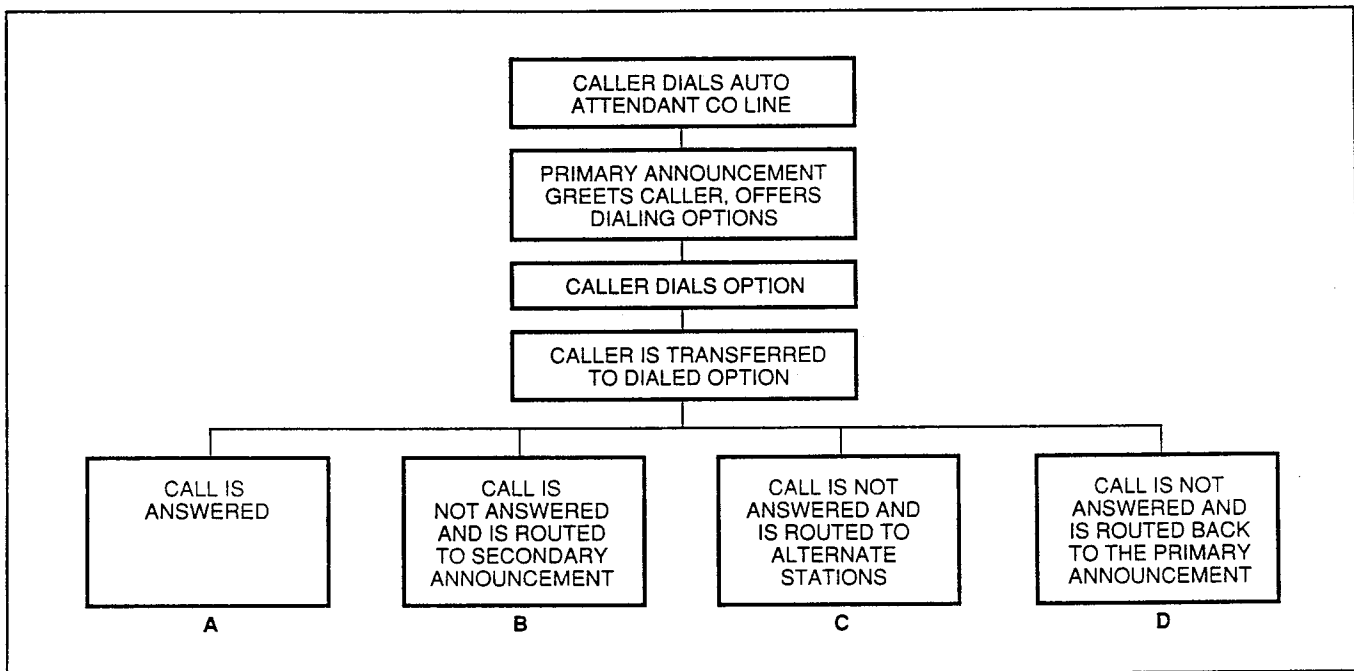
The following describes each of the programs required for the built-in Auto Attendant feature. These descriptions used along with Figures 3, 4, and 5, provide a comprehensive overview of built-in Auto Attendant. Record sheets for each program are attached at the end of this document.

- **Program 78 (61, 62, and 63):** CO lines are assigned for built-in Auto Attendant with this program. There is a limit to the number of lines that can be assigned for Auto Attendant, and each line can be set for any or all of the ringing modes (DAY, DAY2, and NIGHT). See Programs 81 ~ 89 record sheets.
- **Programs 81, 84, and 87:** Used to assign stations to ring if Auto Attendant (AA) callers do not dial or if calls are not answered. Programs 82, 83, etc., delayed ringing options, are not available for this case.
- **Program 03:** Not required on DK8.
- **Program 25-1:** If there are no QRCU2 circuits or announcement devices available for an incoming CO line built-in Auto Attendant call, the call will transfer to alternative station(s) (Programs 81 ~ 89) after a time duration assigned with this program.
- **Program 23:** As many as two digital announcement devices for primary announcements, each requiring a standard telephone station port (Figure 3), can be assigned (only one primary announcement device if using secondary announcement device). Callers receive primary announcements—which consist of the greeting along with the delivery of menu prompts—when they first call (they may also be rerouted back to the primary announcement after reaching a busy or ring no answer station).
- **Program 24:** Transferred calls that are unanswered at stations can be routed to a secondary announcement device, which typically first informs the caller that the option they dialed was unavailable and then presents them with either the same options offered by the primary announcement device or some additional or different options (Figure 3).
- **Program 09:** This program tells the system where to direct calls after incoming Auto Attendant callers dial a digit or digits in response to the menu of dialing prompts offered them by one of the Auto Attendant's digital announcers. The exact dialing prompts along with their associated station numbers are assigned with this program—the actual announcements that are delivered to callers are recorded on customer-supplied digital announcers. The dialing prompts can either be all one-digit or all two-digit. If two-digit is used, the first digit must be dialed before intercom number.
  - As many as nine one-digit dialing prompts (0, or 2-9) can be assigned. Digit 1 is not used, because it conflicts with the system's default intercom numbers. To program one-digit dialing prompts, enter the digit prompt and then its associated intercom number (10 ~ 17).
  - Two-digit dialing prompts are only used when it is necessary to stop the announcement to prevent error in digit translation. Sometimes when line transmission is low or the announcement voice frequencies are the same as a DTMF digit, the system QRCU2 circuit will not dial or it will misdial. The first of the two digits must be either 0, or 2 ~ 9 and must always be the same number for each of the prompts. Therefore, if the leading digit is assigned as 5, callers could be offered all of the following two-digit dialing prompts: 50, 53, 54, 56, 57, 58, and 59; or 5xx where xx is the station intercom number 10 ~ 17. See the Record Sheet for Program 09 for detailed one-digit and two-digit prompt assignment instructions.
  - **Program 26:** There will be times when transferred Auto Attendant calls will not be answered after camp-on to a busy station. This program tells the system when to end the camp-on and to route the call to another destination (it could be a secondary announcement device or alternative stations per Program 23, LED 18). If a station has Call Forward set, the call will forward to the proper destination instead of routing per AA Program 10-3, LED 18.
- **Program 10-3:**
  - **LED 18—**Some customers may opt to configure their Auto Attendant without a secondary announcement device. In these arrangements, transferred calls that are unanswered can be routed for normal ringing to some alternative stations set in Programs 81, 84, and 87, or back to the primary announcement device. LED 18 should be "on" if the calls should be routed to stations assigned

### STRATA DK8 BUILT-IN AUTO ATTENDANT INSTALLATION INSTRUCTIONS



**Figure 3**  
**ANNOUNCEMENT DEVICE BLOCK DIAGRAM**



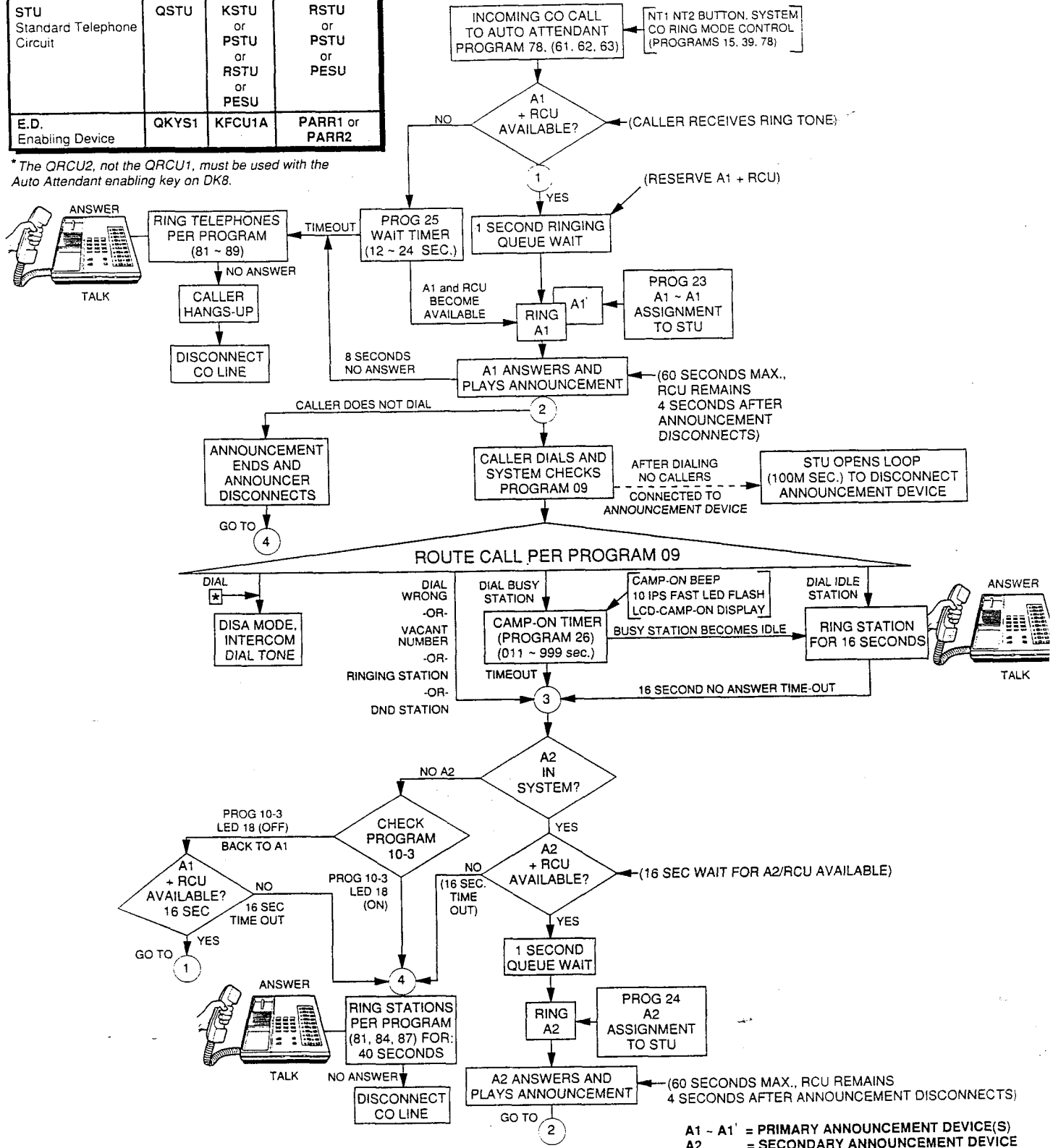
**Figure 4**  
**BUILT-IN AUTO ATTENDANT BASIC CALL SEQUENCES**



## STRATA DK8 BUILT-IN AUTO ATTENDANT INSTALLATION INSTRUCTIONS

RCU / STU / ED	DK8	DK16	DK24/56/96
RCU (DTMF Receiver)	QRCU2*	K4RCU	CRCU or RRCS (4 or 8)
STU Standard Telephone Circuit	QSTU	KSTU or PSTU or RSTU or PESU	RSTU or PSTU or PESU
E.D. Enabling Device	QKYS1	KFCU1A	PARR1 or PARR2

\* The QRCU2, not the QRCU1, must be used with the Auto Attendant enabling key on DK8.



**Figure 5**

**BUILT-IN AUTO ATTENDANT FLOW CHART**

NOTE:  
If two primary announcers are used (A1 and A1') A2 can not be used because there are only 2 QSTU ports.

## STRATA DK8 BUILT-IN AUTO ATTENDANT INSTALLATION INSTRUCTIONS

### PROGRAM 09 — AUTO ATTENDANT PROMPT/STATION ASSIGNMENTS

\*#\*#1\*2\*3 - Spkr - 09 Hold - Spkr   -         - Hold - Spkr ## Hold - Spkr ## Hold

SELECT = PROMPT  
 Select prompt offered to caller.  
 First or second digit.  
 (See Notes 1 and 2).

AUTO ATT DIAL = (1 ~ 4 DIGITS)  
 Select the station intercom numbers which  
 will receive Auto Attendant calls.  
 Could be \* if establishing the leading digit.  
 (See Notes 1, 2 and 5).

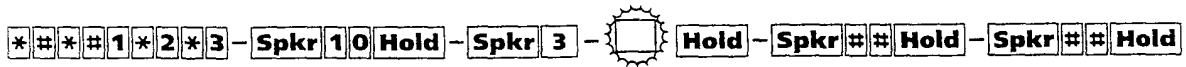
Dialed Digit (Menu Prompts)	Station (Intercom) Number	Department, Division, Etc.
0		
1 (Note 5)		
2		
3		
4		
5		
6		
7		
8		
9		

**NOTES:**

1. To enter one-digit dialing prompts along with their destination station numbers:
  - 1) Enter **Program 09**, and then see "SELECT" on the LCD.
  - 2) Press the desired digit (prompt), and then see "AUTO ATT DIAL" on the LCD.
  - 3) Enter the destination station Intercom (not Port number) number associated with the prompts and then the **Hold (HOLD)** button.
  - 4) Repeat Steps 2 and 3 for more prompt-station entries.
2. To enter two digit dialing prompts along with their destination station numbers:
  - 1) Enter **Program 09**, and then see "SELECT" on the LCD.
  - 2) Press the desired leading digit, and then see "AUTO ATT DIAL" on the LCD.
  - 3) Press \* and then the **Hold (HOLD)** button. The first digit will now be set, and "DATA PROGRAMED" will again appear on the LCD.
  - 4) Press **Spkr** and then press a second digit, "AUTO ATT DIAL" displays on the LCD.
  - 5) Enter the destination station Intercom number assigned to the two-digit prompt and then the **Hold (HOLD)** button.
  - 6) To complete more prompt-station entries, repeat Steps 4 and 5.
3. When transmission and DTMF levels are lower than normal or when the digital announcement voice frequencies match DTMF digital frequencies (talk-off), Auto Attendant efficiency may be improved with two-digit dialing options, instead of one-digit dialing options.
4. Press key LED 01 to delete data.
5. Do not use digit 1 because this number conflicts with the default station (intercom) numbers of the system (10 ~ 17).

## STRATA DK8 BUILT-IN AUTO ATTENDANT INSTALLATION INSTRUCTIONS

### PROGRAM 10-3 — SYSTEM ASSIGNMENTS



SELECT = 3

Buttons/LEDs

Light LEDs as defined by the table below.

ALL LEDs with an "X" should be lit when you finish.

Button/ LED	X	LED ON	LED OFF
20		LCD BLF Displays Port Numbers (00 ~ 09)	LCD BLF Displays Station Numbers (10 ~ 19)
19		Speed Dial Entry Timeout—3 Minutes	Speed Dial Entry Timeout—1 Minute
18		Auto Attd: Normal Ringing Pattern After Camp-on	Auto Attd: Back to Announcement After Camp-on
17			
16			
15			
14			
13			
12			
11			
10			
09			
08			
07			
06			
05			
04			
03			
02			
01			

**NOTES:**

1. Initialized data: all LEDs OFF.

## STRATA DK8 BUILT-IN AUTO ATTENDANT INSTALLATION INSTRUCTIONS

### PROGRAM 23 — PRIMARY AUTO ATTENDANT ANNOUNCEMENT DEVICE ASSIGNMENTS

\*#\*#1\*2\*3 - Spkr 23 Hold - Spkr  -  - Hold - Spkr ## Hold

SELECT = 1 ~ 2  
 Select the Auto  
 Attendant Device  
 (Digital Announcer).

AUTO ATT 1 NO. = Port  
 Enter the port number that  
 the device will be assigned to.

Device	Port Number
1	
2	

### PROGRAM 24 — SECONDARY AUTO ATTENDANT ANNOUNCEMENT DEVICE ASSIGNMENTS

\*#\*#1\*2\*3 - Spkr 24 Hold - Spkr  -  - Hold - Spkr ## Hold

SELECT = 1 ~ 2  
 Select the Auto  
 Attendant Device  
 (Digital Announcer).

AUTO ATT 2 NO. = Port  
 Enter the port number that  
 the device will be assigned to.

Device	Port Number
1	

### PROGRAM 25-1 — INCOMING AUTO ATTENDANT CALL OVERFLOW TIME

\*#\*#1\*2\*3 - Spkr 25 Hold - Spkr 1 -  -  - Hold - Spkr ## Hold - Spkr ## Hold

SELECT = 1

AATT TIME = Seconds Before Overflowing  
 Enter the number of seconds,  
 12 ~ 24.

**NOTES:**

1. For more information, see the instructions preceding the record sheets.
2. Overflow stations are assigned in **Programs 81 ~ 89.**
3. Default overflow time is 20 seconds.
4. This overflow time applies to the overflow of incoming Auto Attendant calls to normal CO line ringing if either a primary announcement device or QRCU2 (DTMF) circuit is not available.

## STRATA DK8 BUILT-IN AUTO ATTENDANT INSTALLATION INSTRUCTIONS

### PROGRAM 26 — BUILT-IN AUTO ATTENDANT CAMP-ON-BUSY TIME

\*#\*#1\*2\*3 - Spkr 26 Hold - Spkr   #   Hold - Spkr ## Hold - Spkr ## Hold

SELECT = Port Number (00~09)  
Enter the number of the called port that needs a Camp-on-Busy time assigned.  
See Note 2 for entering a range of ports.

HOLD TIME = Auto Attendant (AA) Camp-on-Busy Time  
Enter the Time (in seconds).  
The acceptable range is 011 ~ 999 seconds.  
Use three digits. See Note 3.

Port	00	01	02	03	04	05	06	07	08	09
Camp-on Time										

**NOTES:**

1. Initialized data assigns a AA Camp-on-Busy Time of 016 seconds to all ports.
2. To enter a range of ports, key in the sequence:   \*    

Low port 
High port
3. The time period, 999 seconds equals 16.65 minutes.
4. This timer sets the time that Auto Attendant calls to a busy station will camp-on before routing back to a primary announcement or to the calling CO line's normal ring pattern. (See **Program 10-3**, LED 18 for routing option after Camp-on-Busy). The time set in this program applies to the called station.
5. This program only applies to Auto Attendant (Built-in) calls; it does not apply to ring transfer camp-on time from stations or customer-supplied Auto Attendant devices. See **Program 37** Ring Transfer (Camp-on) recall time.

### PROGRAM 78 — CO LINE SPECIAL RINGING ASSIGNMENTS DISA/IMDU/NIGHT RINGING OVER EXTERNAL PAGE/AUTO ATTENDANT

\*#\*#1\*2\*3 - Spkr 78 Hold - Spkr   - Hold - Spkr ## Hold - Spkr ## Hold

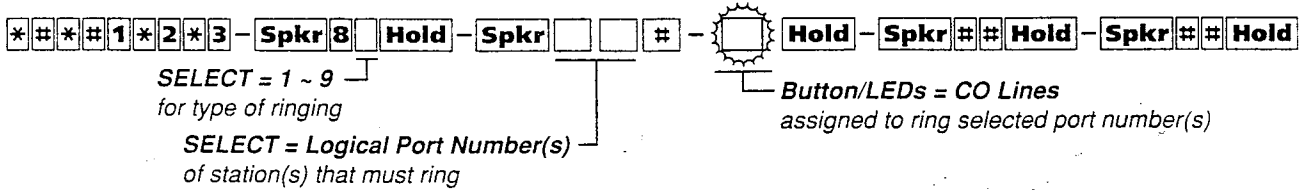
SELECT = Feature Number  
Enter Feature Number 1, 2, or 6.  
  
Code   
Enter Code Number 1 ~ 3.

CO Line  
Specify CO lines by setting LED/Buttons as defined by the table below. All LEDs with an "X" should be lit when finished.

Feature Number	Code	Feature Description	Line No.			
			Key / LED	1 01	2 02	3 03
1	3	Ring Over External Page during NIGHT mode				
2	1	DISA CO Line during DAY Mode				
	2	DISA CO Line during DAY2 Mode				
	3	DISA CO Line during NIGHT Mode				
6	1	Auto Attendant during DAY Mode				
	2	Auto Attendant during DAY2 Mode				
	3	Auto Attendant during NIGHT Mode				

## STRATA DK8 BUILT-IN AUTO ATTENDANT INSTALLATION INSTRUCTIONS

### PROGRAM 8 (1 ~ 9) — CO LINE/STATION RINGING ASSIGNMENTS



Selected CO lines ring selected station ports per Ringing Program options as follows:

- |  |  |  |
|--|--|--|
| <p><input type="checkbox"/> DAY</p> <p>8 <input type="checkbox"/>1 Immediate</p> <p>8 <input type="checkbox"/>2 12 second delay</p> <p>8 <input type="checkbox"/>3 24 second delay</p> | <p><input type="checkbox"/> DAY 2</p> <p>8 <input type="checkbox"/>4 Immediate</p> <p>8 <input type="checkbox"/>5 12 second delay</p> <p>8 <input type="checkbox"/>6 24 second delay</p> | <p><input type="checkbox"/> NIGHT</p> <p>8 <input type="checkbox"/>7 Immediate</p> <p>8 <input type="checkbox"/>8 12 second delay</p> <p>8 <input type="checkbox"/>9 24 second delay</p> |
|--|--|--|

CO	Key / LED	Logical Port Numbers									
		00	01	02	03	04	05	06	07	08	09
04	04										
03	03										
02	02										
01	01										

**NOTES:**

1. For more information, see the instructions preceding the record sheets.
2. Initialized data reads all LEDs ON for Port 00 in **Program 81** and Port 01 in **Program 87**; all other LEDs are OFF.
3. If a CO line must Call Forward or Hunt from a station, the line must be assigned to ring at that station only.
4. A range of ports may be selected.

# **Strata**<sup>®</sup> DK8 & DK16

## **OPERATING PROCEDURES**

**TABLE OF CONTENTS**

**SUBJECT**

OPERATING PROCEDURES:

LIQUID CRYSTAL DISPLAY FEATURES DIGITAL TELEPHONE

DIGITAL TELEPHONE

STANDARD TELEPHONE

ADD-ON MODULE / DIRECT STATION SELECTION CONSOLE

SYSTEM ADMINISTRATOR



**TOSHIBA**

LIQUID CRYSTAL  
DISPLAY FEATURES  
DIGITAL  
TELEPHONE  
USER GUIDE

U S I N E S S  
E L E P H O N E S  
O L U T I O N S



**STRATA® DK**

DIGITAL KEY  
TELEPHONE SYSTEMS  
STRATA DK8 & DK16



## Table of Contents

STRATA DK DIGITAL LCD TELEPHONE

TABLE OF CONTENTS

	SUBJECT
<b>INTRODUCTION</b>	
General Description .....	
Purpose .....	
Organization .....	
How to Use This Guide .....	
<b>CHAPTER 1</b>	
LIQUID CRYSTAL DISPLAY .....	
Liquid Crystal Display .....	
Summary of LCD Functions .....	
<b>CHAPTER 2</b>	
FEATURE OPERATION .....	
Date/Time/Day Adjustment .....	
Call Forward Display .....	
To Set Call Forward .....	
Station-to-Station Message Waiting .....	
Voice Mail (VM) .....	
Busy Field Display .....	
Mode Exit .....	
DISA Security Code: Add/Delete/Change .....	
Toll Restriction Override/Traveling Class Code Change .....	
Verified Account Code Change .....	
<b>CHAPTER 3</b>	
SOFT KEY OPERATION .....	
General Description .....	
How to Use Soft Keys .....	
Using Soft Keys to Make a Conference Call .....	
Soft Key Prompt Definitions .....	
Soft Key Activation .....	
Soft Key Deactivation .....	
<b>CHAPTER 4</b>	
MESSAGES AND MEMOS .....	
LCD AlphaNumeric Messages, Names, Memos .....	
Storing a Message In Memory .....	
Recording a Message .....	
Recording a Message, Name, or Memo .....	
Preprogramming System Messages .....	
Adding to Preprogrammed Messages .....	
Messaging .....	
Calling Station Messaging .....	
Cancelling a Calling Station Message .....	

SUBJECT	PAGE
Setting/Changing Calling Station Messages .....	4-5
Storing LCD Name/Number Display .....	4-5
Speed Dial Memo .....	4-7
Timed Reminders With Memo .....	4-9
Message Sending .....	4-10
Called Station Messaging .....	4-10
Group Called Station Messaging .....	4-11
Remote Calling Station Messaging .....	4-12
Busy Station Messaging .....	4-12
INDEX .....	Index-1

**FIGURE LIST**

FIGURE	TITLE	PAGE
I-1	Sample Page .....	v
I-2	20-button Digital Speakerphone with Liquid Crystal Display .....	vi
4-1	Dialpad Information .....	4-2

## Introduction

### GENERAL DESCRIPTION

The STRATA™ DK 2000-series Digital Liquid Crystal Display telephone provides you with display information and features that make call handling more efficient.

The LCD Feature Prompting with Soft Keys provides a simple way to access frequently-used features. If this feature is active at the station, abbreviated feature prompts help guide you through performing specific tasks.

In addition, the LCD telephones provide you with features such as Call Forwarding, Call Transfer, Call Waiting, Call Transfer with Message, Call Transfer with Message, Busy Lamp Field (BLF) Identification, Central Line Identification, Timed Reminders with Messaging, Speed Dial, Directory Dialing, Intercom User Name/Number Display, Call Display, and Date/Time of Day Display.

### PURPOSE

This document is designed as a feature operating guide for the 2000-series LCD telephones, as well as the 1000-series telephones (models DKT2010-SD, DKT2020-SD, and DKT1020-SD). It covers the LCD functions of the digital telephone. It should be used in conjunction with the *STRATA DK8 & DK16 Digital Telephone* user guide.

An overview of this user guide will acquaint you with the features that are available to your telephone, and will provide you with necessary instructions to perform each feature.

### ORGANIZATION

This user guide is divided into four main chapters. The first chapter explains the Liquid Crystal Display (LCD), including a summary of functions and sample screens. The second chapter explains the operation of each specific calling feature. Operating instructions are provided in an easy-to-follow, step-by-step method. The third chapter explains the operation and use of the Soft Key feature, including Soft Key prompt definitions. The fourth chapter details the call memo features. An index is also included at the back of the book, allowing you to reference material quickly and easily.

### HOW TO USE THIS GUIDE

Your telephone's specific calling allowances are determined by its Class of Service, as determined by system programming. Your system administrator can inform you which features are actually accessible from your specific telephone. Once you are aware of the features that are available to your telephone, review each feature's description and operational procedure contained in this guide.

To assist you in achieving greater performance efficiency, the information in this user guide is divided into distinct areas of content. Instructions for various procedures are referred to as Action Text and appear in the left-hand column of the page. Instructions appear in numerical sequence, enabling you to quickly perform a specific task. More detailed descriptions of these procedures, or explanations of their effects, are located in the right-hand column. The following illustration shows you the structure followed in each Feature Operation section.

**ACTION TEXT**  
 SPECIFIC INSTRUCTIONS ON HOW TO PERFORM A  
 PROCEDURE ARE NUMBERED AND ENTERED IN  
 THE LEFT-HAND COLUMN.

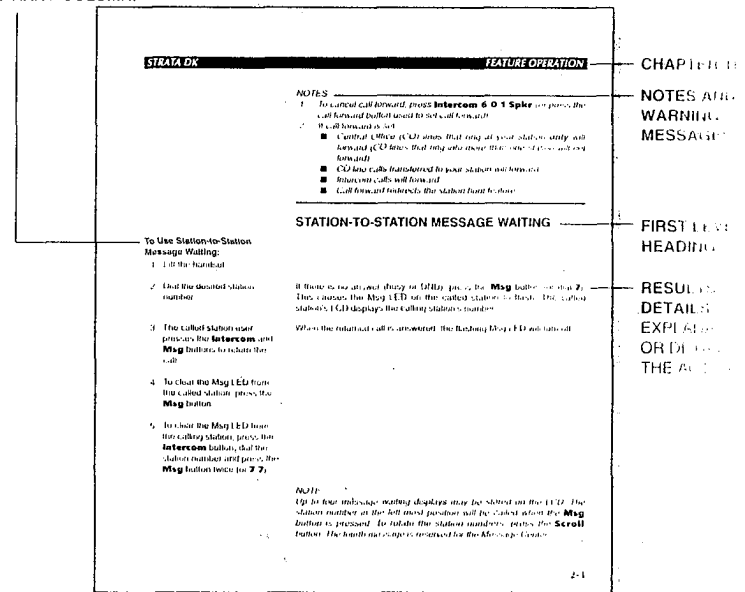


Figure I-1  
 Sample Page

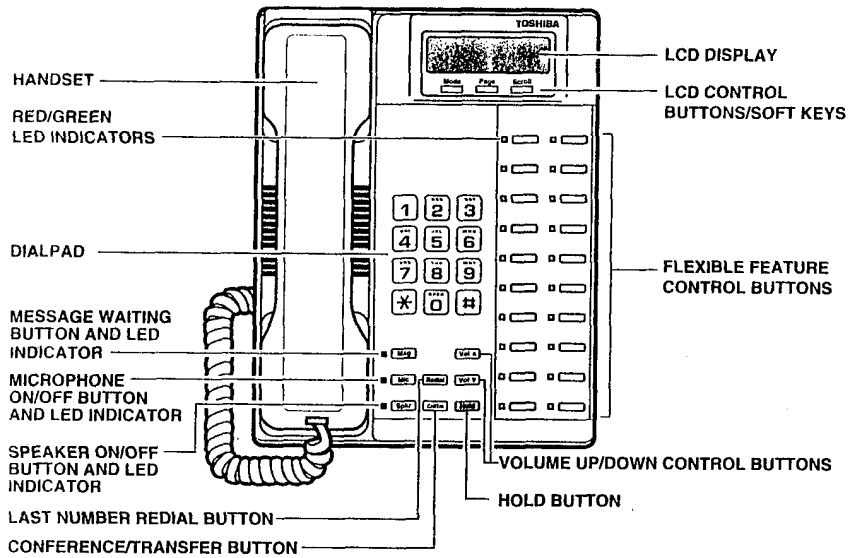
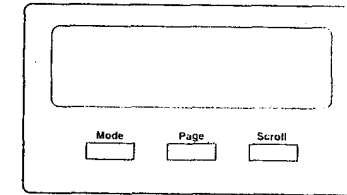


Figure I-2  
20-button Digital Speakerphone with Liquid Crystal Display

## Chapter 1

### LIQUID CRYSTAL DISPLAY

In its idle state, the 32-character Liquid Crystal Display (LCD) on your digital telephone gives you an accurate desk clock and a variety of information displays and feature prompting making handling more efficient. Alphanumeric messaging capabilities are provided. All display functions occur automatically as call processing proceeds. When the Soft Key mode is on, the three buttons on the display are used for LCD feature prompting. Button functions are determined by the label above them on the LCD.



The uses of the three buttons (with Soft Keys off) shown above are:

- Mode:**
1. To enter/exit various mode functions (see "Modes" later in this chapter).
  2. To cancel the beeping tone when using timed reminders.
- Page:**
1. Used to send live messages.
  2. Used by station 10 to record a user NAME/NUMBER to another station. Station 10 must be an LCD digital phone to record a NAME/NUMBER display for any other type.
  3. Changes displays (date/time, elapsed time, time forward, dialed number).
  4. Scrolls through speed dial numbers when using speed dial.

**STRATA DK DIGITAL LCD TELEPHONE**

**LIQUID CRYSTAL DISPLAY**

**CO Line Number:**

1. Incoming Call or Transferred Call

NO. NN  
LINE 3 RINGING

Incoming Central Office (CO) call—if your station is programmed for incoming ringing on that CO line.

NO. NN  
CAMP-ON X

Transferred CO call—CO line is transferred to your station in the ringing state by another station.

Camped-on CO call—CO line was camped-on to your busy station and rings your station when you hang up (X = camped-on line number 1 - 8).

2. When Call Is Answered

NO. NN  
ANSWERED LINE 3

The display changes to indicate calling status.

3. Hold

HOLD LINE X  
JAN 01 SUN 12:19

You have put a CO line call on hold at your station by pressing **Cnf/Trn** or **Hold** button.

4. Hold Recall

HOLD LINE X  
LINE X RECALL

Held call automatically recalls your station after a programmed period of time.

5. Outgoing

NO. NN  
USING LINE X

When you manually select a CO line, it is displayed. This display is replaced by the dialed number as you dial.

6. CO Line Queuing (Callback)

NO. NN  
LINE X ACB

When the CO line queuing feature rings back to your station with an available CO line, that line number will be displayed.

**Date/Time:**

NO. NN  
MAY 24 MON 12:05

1. Press the **Page** button to display date/time when talking on a Central Office (CO) line (Soft Keys must be off before the call is started).
2. The date/time is **adjusted** on a system-wide basis by the station located in port 00 (usually station 10).

**STRATA DK DIGITAL LCD TELEPHONE**

**Dialed Number:**

1. CO Line

NO. NN  
5551374

The digits are displayed for the intercom user:  
 Manual dialing  
 Automatic dialing  
 Repeat last number  
 Saved number

**NOTE:**  
If you are calling a number, the dialed number is displayed.

2. Intercom

NO. NN  
YY

When you call an intercom user, the intercom user's number is displayed.

**Door Phone/Monitor:**

NO. NN  
DOOR PHONE 1A

When you are calling a door phone, the door phone number is displayed.

NO. NN  
DOOR PHONE 1A

When you call a door phone, the door phone number is displayed.

**NOTE:**  
The door phone number is displayed when you call a door phone.

**Elapsed Time:**

NO. NN  
00:13:23

While you are on a call, the elapsed time of the call is displayed. (Timing begins when you answer the call.)

- NOTES:**
1. On a CO line, the elapsed time is displayed when you answer the call (Soft Keys must be off before the call is started).
  2. Elapsed time is displayed when you answer the call.

**STRATA DK DIGITAL LCD TELEPHONE**

**LIQUID CRYSTAL DISPLAY**

**Intercom Number Display:**

NO. NN  
INT = NN

To find out what your intercom or extension number is if does not appear on your display, press **Intercom 4 0 1** or **CONF 4 0 1** and the intercom number will be displayed.

**LCD Name/Number Display:**

1. Idle Station

NAME/NUMBER  
DATE DAY TIME

A name or title may be set in memory for each station. When an LCD station is idle, the name displays on the top line of the LCD. When a station calls an LCD station, the name of the calling station displays on the bottom line of the called station's LCD. If your station has Soft Keys turned on, the NAME/NUMBER of the telephone you call will display.

2. Called Station

NO. NN  
NAME/NUMBER

**Least Cost Routing (LCR):**

NO. NN  
DIAL TEL NUMBER

When you are making a call via Least Cost Routing (LCR), your display will prompt you to dial a number by displaying "DIAL TEL NUMBER".

NO. NN  
5833700

As you dial the number, it is shown on your display.

**Message Waiting:**

NO. NN  
INT NN MW SET

When you set message waiting at another station, the number of that station is displayed.

SENT NN  
JAN 01 SUN 12:19

When you hang up after setting message waiting at another station, a reminder is shown on the top row of your display. If you want to remove the SENT NN display, press the **Page** key twice.

NO. NN  
CALL WW YY ZZ

Your display will show the numbers of up to three stations that have left messages for you (WW YY ZZ). Four numbers may be stored in message memory (see Recalling Station).

**STRATA DK DIGITAL LCD TELEPHONE**

**LIQUID CRYSTAL DISPLAY**

**Message Waiting/Voice Mail:**

NO. NN  
CALL WW YY V+

When a message waiting voice mail is displayed, a "V" and the station number. A "+" indicates that there is a station in memory. Press the **Scroll** button to rotate through more numbers.

**Off-hook Call Announce:**

NO. NN  
WW

When you off-hook call announce to a busy station, your LCD displays the number of that station.

NO. NN  
YY BUSY OVR

When another station off-hook call announces to your station, your LCD displays the number of that station (YY).

**Overrides:**

1. Busy Override

NO. NN  
YY BUSY OVR

When you activate the override feature after calling a busy station, the station number (YY) and the feature are displayed.

NO. NN  
YY BUSY OVR

Your LCD telephone displays the number of a station that has overridden when you are on the telephone. The number is displayed until override is disconnected.

2. Executive Override

NO. NN  
YY EXEC OVRD

When you initiate executive override, your LCD telephone displays the number of the station (YY) that is overridden. The station that the override displays your station number. The number is displayed until the call is ended.

3. Do Not Disturb (DND) Override

NO. NN  
INT YY DND

The station you have called is in the Do Not Disturb (DND) mode.

NO. NN  
YY DND OVR

When you initiate Do Not Disturb override, the station number that has overridden is displayed.

NO. NN  
YY DND OVR

When another station overrides Do Not Disturb at your station, the station number (YY) is displayed. (The display remains until the call ends.)

**STRATA DK DIGITAL LCD TELEPHONE**

**LIQUID CRYSTAL DISPLAY**

- Scroll:** 1. Scrolls through message waiting numbers.  
 2. Scrolls through the speed dial digits (if more than 16 digits) when in Mode 8.

**NOTE:**  
 If your telephone has the Soft Key feature turned on (Mode 71), the Mode, Page, and Scroll functions are not active when the telephone is busy on a CO line or Intercom call. Mode, Page, and Scroll are only used when the telephone is idle.

**MODE DEFINITIONS**

- MODE 0:** Used to exit another mode and return to clock/calendar display.  
**MODE 1:** Busy Field display.  
**MODE 2:** Busy station messaging.  
**MODE 4:** Called station messaging.  
**MODE 8:** Speed dial number check and memo dialing.  
**MODE 71:** Soft key ON.  
**MODE 70:** Soft key OFF.  
**MODE 94:** Remote called station messaging.  
**MODE 95:** Remote calling station messaging.

**STRATA DK DIGITAL LCD TELEPHONE**

**LIQUID CRYSTAL DISPLAY**

**SUMMARY OF LCD FUNCTIONS**

**IMPORTANT NOTE!**  
 All Liquid Crystal Display (LCD) examples in this user manual are shown with soft keys turned OFF. If your telephone has soft keys turned ON, the displays may be different, but they will still follow the steps in this guide. Generally, the information on line 2 will display on line 1.

**NOTE:**  
 "NN" on the top row of the LCD indicates the station intercom number when a station is idle. Intercom numbers are normally 1-99. If an Intercom Name is set, it will replace the intercom number display.

When you press a Central Office (CO) line that requires a verified or nonverified) account code; or dial \* 5 0, or press the **Account Code** button to enter a voluntary (verified or nonverified) account code.

When you dial a verified voluntary account code that is not valid.

When you correctly dial a verified voluntary account code that is not in the system account code memory.

When you dial a verified forced account code that is not valid.

After you dial a verified forced account code that is valid.

After setting auto busy redial, your display prompts you that it is set. ("X" indicates the CO line number (1 - 4 for DK8, 1 - 8 for DK9).

When the system dials the call, your display shows the dialed number. The system inserts a pause (P) before redialing the number.

When the called telephone is ringing, your station's Central Office LED (or Intercom LED) and Spkr LED will flash, and a warning tone will sound 30 seconds after the call is completed.

**Account Codes:**

NO. NN  
 ENTER ACCT CODE

NO. NN  
 CODE NOT VALID

NO. NN  
 CODE VERIFIED

NO. NN  
 DIAL RESTRICTED

NO. NN  
 DIAL TEL NUMBER

**Auto Busy Redial (ABR):**

HOLD LINE X  
 ABR SET

NO. NN  
 P 5 8 3 3 7 0 0

**STRATA DK DIGITAL LCD TELEPHONE**

**LIQUID CRYSTAL DISPLAY**

NO. NN  
LINE X ACB

Your station will display the called number, followed by "LINE X ACB", 30 seconds later.

**Automatic Callback (ACB):**

NO. NN  
INT NN ACB SET

When you set automatic callback at a busy station, its number is displayed.

NO. NN  
NN ACB

When you receive an automatic callback, the station number you called is displayed.

NO. NN  
LINE X ACB

When you receive an automatic callback for a Central Office (CO) line, the seized line's number is displayed.

**Automatic Line Selection:**

**1. Intercom Line**

NO. NN  
INT

If your station automatically accesses an intercom line when you go off-hook, INT is displayed.

**2. CO Line**

NO. NN  
USING LINE X

If your station automatically accesses a Central Office (CO) line when you go off-hook, the number of the seized CO line is displayed.

**3. Dial Access Code**

NO. NN  
USING LINE X

When you access a Central Office (CO) line by dialing a CO line group access code, the accessed CO line number is displayed.

**Alphanumeric Messages:**

BACK AT 2PM-CALL  
MEETING FOR 3PM

Messages of up to 32 characters may be used in alphanumeric messaging. Messages may either be programmed or set as one-time messages. (Messages may also be used with a timed reminder.)

**Busy Field:**

10 0 .....5.....  
20 .....7.....

The Busy Field display indicates the last two digits of the station numbers that are busy or set for Do Not Disturb (DND). This sample display indicates that stations 10, 15, and 27 are either in use or in DND mode. If your system follows the default 2-digit station intercom number plan, the Busy Lamp Field (BLF) display indicates the station number. When turned on, the BLF display has first priority; it will block out all other LCD displays. In the case of station relocation, the BLF will display the number assigned to the station's logical port.

**STRATA DK DIGITAL LCD TELEPHONE**

**LIQUID CRYSTAL DISPLAY**

**Call Forward:**

CALL FORWARD TO

When you initiate any type of call forward, the LCD displays "CALL FORWARD TO".

After you set call forward, the station number to which your call forwarded is displayed, along with one of the following abbreviations:  
 "CF-AC" (Call Forward-All Calls)  
 "CF-BUSY" (Call Forward-Busy)  
 "CF-NA" (Call Forward-No Answer)  
 "CF-B/NA" (Call Forward-Busy/No Answer)  
 "CF-FIXED TO STNN" (Call Forward-Fixed)

NO. NN  
ZZ

When your call is forwarded to another station, the station number shown first. It then changes to the station to which your call is forwarded (ZZ).

NO. NN  
YY CALL ZZ

When a call is forwarded to your station, the calling station number is displayed on the left and the station called (ZZ) is displayed on the right.

**Call Pickup:**

NO. NN  
YY CALL ZZ

When you pick up an intercom call, the calling station's number is displayed on the left and the station number called (ZZ) is displayed on the right.

NO. NN  
YY PICKUP ZZ

Your LCD telephone displays information noting that your call (YY) was picked up by station ZZ.

**Calling Number-Intercom:**

NO. NN  
NN CALLING

When you receive an intercom call, the calling station number is displayed. If user name is set on the calling station, the user name is displayed instead of "NN CALLING".

**CO Line Identification:**

TOSHIBA TELECOM

The Central Office (CO) lines can be programmed to display an identifying name of up to 16 characters. The name will be displayed on outgoing and incoming calls.

WATS LINE 3



## Index

### STRATA DK DIGITAL LCD TELEPHONE

#### A

Account Code  
 Calls 1-3  
 Changes 2-7  
 Alphanumeric Messages 1-4, 4-1  
 Auto Busy Redial Display 1-3  
 Automatic Callback Display 1-4  
 Automatic Line Selection Display 1-4

#### B

Busy Field Display 1-4, 2-5  
 Busy Override Display. *See* Override Displays  
 Busy Station Messaging 4-12

#### C

Call Forward  
 Display 1-5  
 Setting 2-2  
 Call Number-Intercom Display 1-5  
 Call Pickup Display 1-5  
 Called/Calling Station Messaging. *See* Messages and Memos  
 Conference Calls 3-1  
 CO Line Identification Display 1-5  
 CO Line Number Display 1-6

#### D

Date/Time/Day  
 Adjustment 2-1  
 Display 1-6  
 Dialed Number Display 1-7  
 Dialpad Information 4-2  
 Direct Inward System Access (DISA) Security Code 2-5  
 Do Not Disturb Override Display. *See* Override Displays  
 Door Phone/Monitor Display 1-7

#### E

Elapsed Time Display 1-7

Executive Override Display. *See* Override Displays

#### G

Group Called Station Messaging. *See* Messages and Memos

#### I

Intercom Number Display 1-7

#### L

Liquid Crystal Display  
 Feature Buttons 1-1  
 Functions 1-1, 1-3  
 Name/Number 1-8, 4-5  
 Least Cost Routing Display 1-8

#### M

Message Waiting  
 Display 1-8  
 Use of 2-3  
 Messages and Memos 4-1  
 Called Station Messaging 4-10  
 Calling Station Messaging 4-4  
 Group Called Station Messaging 4-11  
 Preprogrammed 4-3  
 Recording 4-1  
 Remote Calling Station Messaging 4-12  
 Sending 4-10  
 Storing 4-1  
 System Messages 4-3  
 Mode  
 Button 1-1  
 Definitions 1-2  
 Exit 2-5

#### O

Off-hook Call Announce Display 1-9  
 Override Displays 1-9

#### P

Page Button 1-1  
 Privacy Override Display  
 Override Displays  
 Preprogrammed Messages and Memos

#### R

Recalling Station Display  
 Recording a Message  
 Messages and Memos  
 Remote Calling Station Messaging. *See* Messages and Memos

#### S

Scroll Button 1-2  
 Soft Keys 3-1  
 Prompt Definitions  
 Activation/Deactivation  
 Speed Dial  
 Display 1-10  
 Use of 4-7  
 Station to Station Messaging  
 Waiting. *See* Messages and Memos  
 Store a Message. *See* Messages and Memos  
 System Messages  
 and Memos

#### T

Timed Reminders 4  
 Toll Restriction Override  
 Traveling Class Code  
 Display 1-10  
 Setting 2-6  
 Two-CO Line Call Display

#### V

Verified Account Code  
 Voice Mail (VM)  
 Display 1-9  
 Use of 2-4

**TOSHIBA**

D I G I T A L  
T E L E P H O N E  
U S E R G U I D E

B U S I N E S S  
T E L E P H O N E  
S O L U T I O N S

▶ **STRATA® DK**

D I G I T A L K E Y  
T E L E P H O N E S Y S T E M S  
S T R A T A D K 8 & D K 1 6



## Table of Contents

**STRATA DK DIGITAL TELEPHONE**

**TABLE OF CONTENTS**

### SUBJECT

#### INTRODUCTION

General Description .....	
Purpose .....	
Organization .....	
How to Use This Guide .....	

#### CHAPTER 1

GENERAL INFORMATION .....	
Purpose .....	
Feature Buttons .....	
LED Indications .....	
Line Button LED Indications .....	
Feature Button LED Indications .....	
Volume Controls .....	
Ring Tone Volume (Incoming Handsfree Answerback) .....	
Incoming Handsfree Answerback Volume (Ring Tone) .....	
Handset Receiver Volume .....	
Speaker Volume .....	
Muted Tone Burst Volume .....	
Microphone Sensitivity Control .....	
High-noise Sensitivity .....	
Normal Sensitivity .....	
Handset/Headset Call Waiting Tone Option .....	
On-hook/Off-hook .....	

#### CHAPTER 2

FEATURE OPERATION .....	
Outside Calls .....	
On-hook Dialing .....	
Outside Calls .....	
Intercom Calls .....	
Group Listening .....	
Automatic Off-hook Selection .....	
Repeat Last Number Dialed .....	
Automatic Busy Redial .....	
Speed Dial .....	
Station Speed Dial Storage .....	
System Speed Dial Storage .....	
Speed Dial Pause and Flash Storage .....	
Speed Dial Number Linking .....	

SUBJECT	PAGE
Calling System or Station Speed Dial Numbers	2-10
Chain Dialing Speed Dial Numbers	2-11
Saved Number Redial	2-11
DTMF Tone Dialing With * and #	2-12
Tone/Pulse Dialing	2-12
Privacy Override	2-13
Privacy Button	2-14
Privacy Release	2-14
Intercom Calls	2-15
Tone/Voice First Signaling	2-16
Handsfree Answerback	2-17
Handsfree Answerback Volume Control	2-17
Microphone Cut-off	2-17
Off-hook Call Announcement (OCA)	2-18
Forced Disconnect	2-18
OCA Volume Control	2-19
Call Transfer with Camp-on	2-19
Answering a Transferred Call	2-20
Conference Calls	2-22
Conference with Stations and CO Lines	2-22
Conference with Stations Only	2-23
Call Forward	2-23
Call Forward-All Calls	2-24
Call Forward-Busy	2-25
Call Forward-No Answer	2-25
Call Forward-Busy/No Answer	2-26
Call Forward-Fixed	2-27
Call Hold	2-28
Call Park	2-28
Exclusive Hold	2-29
Call Pickup	2-30
Directed Call Pickup	2-30
Do Not Disturb	2-31
Automatic Callback	2-32
CO Line Queuing with Automatic Callback	2-33
Account Code Calls	2-34
Forced Account Codes	2-34
Emergency Override of Forced Account Codes	2-34
Voluntary Account Codes	2-34
Verified Account Code Changes	2-35
Paging	2-36
All Call Page Button	2-37

SUBJECT	PAGE
Door Phone	2-38
Handsfree Monitoring	2-38
Alarm Reset	2-38
Background Music (BGM) Over Telephone Speakers	2-38
Background Music (BGM) Over External Speakers	2-38
Direct Inward System Access (DISA)	2-38
DISA Security Code Entry/Change/Cancel	2-38
Direct Station Selection Buttons (Hotline)	2-38
Door Lock	2-38
Message Waiting	2-38
Night Transfer	2-38
Override Calls	2-38
Speakerphone	2-38
Outside Calls	2-38
Intercom Calls	2-38
Microphone Control	2-38
Two (Tandem) CO Line Connection	2-38
Supervision	2-38
Timed Reminders	2-38
Toll Restriction Override	2-38
Toll Restriction Override Code Revision	2-38
Automatic Hold	2-38
User Programmable Feature Buttons	2-38

**CHAPTER 3**

**TOSHIBA VP INTEGRATION**

Using The Toshiba VP Voice Mail System

Call Forward

Voice Mail Identification Code

Call Forward to Toshiba VP Voice Systems

Voice Mail Message Retrieval

**CHAPTER 4**

**CENTREX APPLICATION**

General

Flexible Intercom Numbering

Centrex Feature Buttons

Ringing Repeat

Delayed Ringing

# Introduction

SUBJECT	PAGE
APPENDIX A 1000-series Button Designations .....	A-1
GLOSSARY .....	G-1
INDEX .....	Index-1

## FIGURE LIST

FIGURE	TITLE	PAGE
I-1	Sample Page .....	vii
I-2	2000-Series Telephones .....	viii

## TABLE LIST

TABLE	TITLE	PAGE
2-A	Feature Access Code List .....	2-55

## GENERAL DESCRIPTION

Toshiba digital telephones incorporate state-of-the-art telecommunications technology and provide a vast array of features. They are easy to operate, and all features are accessed by a feature button or a brief access code.

## PURPOSE

This document is designed as a guide to using the 2000-series and older 1000-series digital telephones for a STRATA DK8 or DK9 series model. Feature operations in this guide use the button designations for the 2000-series models. Refer to Appendix A for 1000-series designations.

The following telephone models belong to the 2000-series and are depicted in Figure I-2:

- DKT2010-H (10-button model that allows users to answer calls without lifting the handset)
- DKT2010-SD (10-button model equipped with a Liquid Crystal Display (LCD) and a speakerphone which allows users to answer calls outside and intercom calls without lifting the handset)
- DKT2020-S (20-button speakerphone model which allows users to make and receive outside and intercom calls without lifting the handset)
- DKT2020-SD (20-button model equipped with an LCD, a speakerphone which allows users to make and receive outside and intercom calls without lifting the handset)

The following telephones comprise the 1000-series:

- DKT1020-H (20-button speakerphone model that allows users to answer intercom calls without lifting the handset)
- DKT1020-SD (20-button model equipped with an LCD and a speakerphone which allows users to make and receive outside and intercom calls without lifting the handset)

This user guide covers all of the voice calling features, including Hold, Hold and Call Forward, available with each of the phones.

Your digital telephone may have an LCD for message and/or a data interface unit for data calling. Refer to the Digital Telephone LCD User Guide and the Data Interface Unit User Guide for details on how to operate these options.

## ORGANIZATION

This user guide is divided into the following sections.

The Introduction consists of a general description of the digital telephones as well as the purpose and organization of this document. Suggestions on how to use the user guide also appear in this section.

Chapter 1, "General Information," provides descriptions of the functions of all the feature buttons along with their associated Light Emitting Diodes (LEDs) available to the telephones.

Chapter 2, "Feature Operation," contains descriptions and operating procedures for all of the voice calling features offered by the telephones.

Chapter 3, "Toshiba VP Integration," explains how to set up your telephone to forward calls to a Toshiba Voice Processing System and to retrieve recorded messages left by callers.

Chapter 4, "Centrex Application," describes the Centrex features which may be available with your STRATA DK system.

Appendix A provides a list of the feature button designations of the 1000-series Digital Telephone models.

A glossary and an index are located at the end of the user guide.

## HOW TO USE THIS GUIDE

Most of the features in this guide are available with your telephone. Your system administrator can tell you which features you can access.

The information in this user guide is divided into distinct areas of content. Instructions for various procedures are referred to as Action Text and appear in the left-hand column of the page. Instructions appear in numerical sequence, enabling you to quickly perform a specific task. More detailed descriptions of these procedures, or explanations of their effects, are located in the right-hand column. Figure 1-1 shows you the structure followed for each feature operation.

**ACTION TEXT**  
SPECIFIC INSTRUCTIONS ON HOW TO PERFORM A PROCEDURE ARE NUMBERED AND ENTERED IN THE LEFT-HAND COLUMN.

**NOTES AND WARNING MESSAGES**

STRATA DK	FEATURE OPERATION	CHAPTER
	<p><b>HANDSFREE ANSWERBACK</b></p> <p>You can answer intercom calls without lifting the handset.</p> <p><b>To Receive a Handsfree Intercom Call:</b></p> <ol style="list-style-type: none"> <li>1. You will hear a single ring tone followed by the caller's name.</li> <li>2. Don't lift the handset; speak toward the telephone in a normal voice level.</li> </ol> <p>The Intercom LED will flash green at the incoming call tone. The Mic LED will light steadily, indicating your intercom call tone. The Speaker LED will flash red.</p> <p>If you have a speakerphone, you will have better performance if you press the Intercom button.</p> <p><b>NOTE:</b> The Intercom button must be pressed or the handset must be taken off hook before placing an intercom call or first.</p> <p><b>HANDSFREE ANSWERBACK VOLUME CONTROL</b></p> <p>You can control the volume of the Handsfree Answerback feature.</p> <p><b>To Change the Volume while on the Call:</b></p> <ol style="list-style-type: none"> <li>1. Press the up or down Vol button until the desired level is set.</li> </ol> <p>You can also control this volume while in the state. In the state, press the up or down Vol button and hear ring tone. Continue pressing the button until the desired volume is set. Adjusting this volume will also change ring tone volume.</p> <p><b>MICROPHONE CUT-OFF</b></p> <p>Microphone Cut-off prevents callers from monitoring the sounds near your telephone. Your system may be equipped with the Microphone Cut-off button in system programming to activate this feature.</p> <p><b>To Turn Off the Microphone:</b></p> <ol style="list-style-type: none"> <li>1. Press the Microphone Cut-off button.</li> </ol> <p>After you press the button, the Microphone Cut-off LED will light steadily, and the Mic and Speaker LEDs will not turn on when your telephone is being called.</p>	<p>CHAPTER</p> <p>FIRST LEVEL HEADING</p> <p>SECOND LEVEL HEADING</p> <p>EXPLANATION</p>
	<p>2-17</p>	

Figure 1-1 Sample Page

# Chapter 1

## PURPOSE

This chapter is designed to familiarize you with the controls and indicators located on your telephone. Understanding the function of the feature buttons and their associated LEDs will improve your ability to use the telephone and will help you to take advantage of all of the benefits offered by your telephone.

## FEATURE BUTTONS

Some of the feature buttons described below appear on your telephone, depending on just how it is programmed. The button label designations for 2000-series telephones are provided here. The designations for the 1000-series models are in Appendix A.

### 2000-SERIES BUTTONS

#### Account Code

#### ACCOUNT CODE BUTTON

Press to enter a Voluntary Account Code anytime during a CO line interrupting the conversation.

#### Alarm Reset

#### ALARM RESET BUTTON

Press to turn off a telephone alarm connected to a facility alarm mechanism.

#### All Call Page

#### ALL CALL VOICE PAGE BUTTON

Press to page all of the digital and electronic telephones in the All Call Page.

#### Auto Busy Redial

#### AUTOMATIC BUSY REDIAL BUTTON

Press to set up Automatic Busy Redial after receiving busy tone on a station call.

#### Auto Callback

#### AUTOMATIC CALLBACK BUTTON

Press to recall a busy station or station in the Do Not Disturb Mode (DND) that station becomes idle or deactivates DND. Also used for CO line queuing.

#### Call Frwd All Calls

#### CALL FORWARD-ALL CALLS BUTTON

Press to forward all calls to another station or voice mail device.

#### Call Frwd Busy

#### CALL FORWARD-BUSY BUTTON

Press to forward calls immediately to another station or voice mail device when station is busy or in the Do Not Disturb mode.

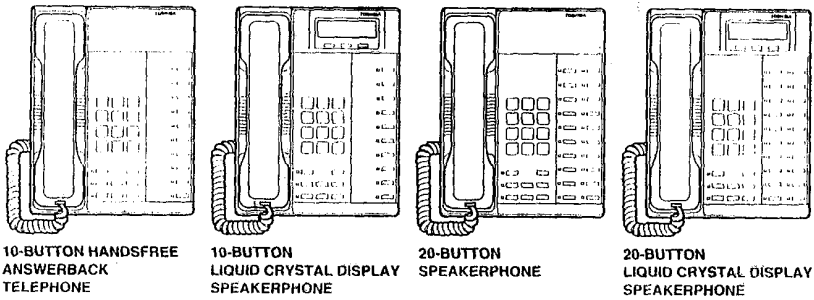
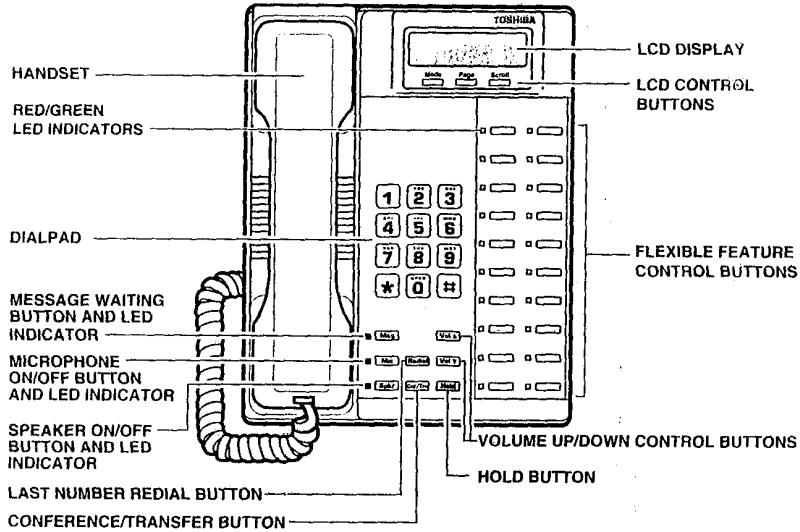


Figure 1-2  
2000-Series Telephones

**STRATA DK DIGITAL TELEPHONE**

**GENERAL INFORMATION**

**2000-SERIES  
BUTTONS**

**Call Frwd  
Busy NAns**

**CALL FORWARD-BUSY/NO ANSWER BUTTON**  
Press to forward calls immediately to another station or voice mail device when your station is busy or in the Do Not Disturb (DND) mode. Also forwards calls when your station is not answered after three rings or 12 seconds.

**Call Frwd  
No Answer**

**CALL FORWARD-NO ANSWER BUTTON**  
Press to forward calls to another station or voice mail device when your station is not answered after three rings or 12 seconds.

**Call Frwd  
to: \_\_\_\_\_**

**CALL FORWARD-FIXED BUTTON**  
Press to forward all calls to a station or voice mail device assigned in system programming.

**Conf/Tm**

**CONFERENCE/TRANSFER BUTTON (FIXED)**  
Press to set up conference and transfer calls.

**Data  
Call**

**DATA BUTTON**  
Press to enable manual dialing of internal data calls. See the *STRATA DK Data Interface User Guide*.

**Data  
Release**

**DATA RELEASE BUTTON**  
Press to release data calls. See the *STRATA DK Data Interface User Guide*.

**Directed  
Pickup**

**CALL PICKUP BUTTON**  
Press to initiate a Directed Call Pickup of CO line, intercom, and page calls.

**Directed  
Pickup1  
or  
Directed  
Pickup2**

**TENANT CALL PICKUP BUTTONS**  
If the system is shared by two tenants, the **Directed Pickup1** button is used to pick up Tenant 1 ringing CO line calls, and the **Directed Pickup2** button is used to pick up Tenant 2 ringing CO line calls.

**Do Not  
Disturb**

**DO NOT DISTURB BUTTON**  
Press to lock your station in or out of the Do Not Disturb (DND) mode.

**DSS: \_\_\_\_\_  
or  
Customized Button**

**DIRECT STATION SELECTION BUTTON(S)**  
Press to ring a preselected station. The LED associated with each **DSS** button provides the status (idle/busy) of the station assigned to the button.

**STRATA DK DIGITAL TELEPHONE**

**GENERAL INFORMATION**

**2000-SERIES  
BUTTONS**

**Flash**

**FLASH BUTTON**  
Press to perform the following functions: Disconnect and recall dial tone to access Centrex or PBX features; enter a pause or flash signal when pressing Speed Dial numbers.

**Hold**

**HOLD BUTTON (FIXED)**  
Press to hold internal or outside calls.

**Intercom**

**INTERCOM BUTTON**  
Press to access the intercom.

**LCD Msg  
Select**

**MESSAGE SELECT BUTTON**  
Press to allow system and personal messages to be displayed on the 16-character Liquid Crystal Display (LCD).

**Line**

**LINE BUTTON**  
Press to access an outside line.

**Mic**

**MICROPHONE BUTTON (FIXED)**  
Press to turn the microphone off/on while telephone is in use.

**Microphn  
Cut-off**

**MICROPHONE CUTOFF BUTTON**  
Press to turn the microphone off/on while idle, providing privacy when using handsfree intercom calls. Also functional when your station receives call pickup; button controls the microphone when you originate calls.

**Modem**

**MODEM BUTTON**  
Press to reserve a modem from a pool. The LED of the button indicates when the modem pool. See the *STRATA DK Data Interface User Guide*.

**Msg**

**MESSAGE WAITING BUTTON (FIXED)**  
The Msg LED flashes to indicate that a message is waiting. After using intercom, press the **Msg** button to call back the station or voice mail device; activated the LED.

**Night  
Transfer**

**NIGHT TRANSFER BUTTON**  
Press to control the system's CO line ringing pattern for after hours incoming calls.

**STRATA DK DIGITAL TELEPHONE**

**GENERAL INFORMATION**

**2000-SERIES  
BUTTONS**

- Night Transfer1**  
or  
**Night Transfer2**      **TENANT NIGHT TRANSFER BUTTONS**  
Press the appropriate button to control the system's CO line ringing patterns for after hours incoming calls for either of the tenants that share a single STRATA DK system.
- Pooled Line Grp**      **POOLED LINE BUTTON**  
Press to access an available CO line from a group of lines appearing under one button.
- Privacy on Line**      **PRIVACY BUTTON**  
Press to block Privacy Override on common CO line buttons. This button does not block Busy Override or Executive Override.
- Privacy Release**      **PRIVACY RELEASE BUTTON**  
Press to release privacy on common CO line buttons, enabling other station users to enter your conversations on those buttons.
- Redial**      **REDIAL BUTTON (FIXED)**  
Press to have the system redial the last telephone number you dialed.
- Release Call**      **RELEASE BUTTON**  
Press to disconnect a call and to place your station in the idle condition.
- Save Last Number**      **SAVE BUTTON**  
After dialing an outside or intercom number, press to "save" the number so that later you can have the system automatically redial the number for you when you press the button after accessing an outside line or the intercom.
- SD**  
or  
**Customized Button**      **SPEED DIAL BUTTON**  
Press to Speed Dial a telephone number or feature access codes.
- Speed Dial**      **SPEED DIAL SELECT**  
Press to store and to access Speed Dial numbers.
- Spd Dial Lng Pause**      **PAUSE (LONG) BUTTON**  
Press to insert a 10-second pause when programming Speed Dial numbers.

**STRATA DK DIGITAL TELEPHONE**

**GENERAL INFORMATION**

**2000-SERIES  
BUTTONS**

- Spd Dial Pause**      **PAUSE BUTTON**  
Press to set either a one-half or two-second pause when programming Speed Dial numbers. (The pause time is set in system programming.)
- Spkr**      **SPEAKER BUTTON (FIXED)**  
Press to turn the speaker on/off. The **Spkr** button will also select a line or feature if programmed for auto preference in system programming. Also, used to turn on-hook speakerphone calls.
- Tel Set Music**      **BACKGROUND MUSIC BUTTON**  
Press to turn Background Music on or off over your station speaker.
- Tone Dial Select**      **STONE BUTTON**  
Press to change the outgoing dialing of the CO line in use from dial pulse to tone signaling.
- Unlock Door**      **DOOR LOCK BUTTON**  
Press to unlock a door lock mechanism.
- Vol Δ**  
**Vol ▽**      **VOLUME BUTTON (FIXED)**  
Press to adjust volume levels. See "VOLUME CONTROLS" later in this chapter.

**LED INDICATIONS**

Each line and feature button has a Light Emitting Diode (LED) which indicates the status of the line or feature associated with the button.

**LINE BUTTON LED INDICATIONS**

Line LEDs light as red or green and flash at varying rates to indicate status.

**Line In-use**--When you access an outside line, the LED will indicate your station as follows:

- Flash rate: 2 seconds on—1/8 second off—1/8 second on—1/8 second off
- Color: Green
- Other stations with the Line: Steady, red



**Incoming Call**—While an incoming call is ringing your station, the Line LED will appear at your station as follows:

- Flash rate: 1/2 second on—1/2 second off
- Color: Red for direct calls, green for transferred calls
- Other stations with the Line: Steady, red

**On Hold**—When you place an outside line on hold, the Line LED will appear at your station as follows:

- Flash rate: 4 impulses per second for 1/8 second—1/8 second off
- Color: Green
- Other stations with the Line: 3/4 second on—1/8 second off, red

*NOTE: If using a pooled line button, the hold indication is only at the station that places the call on hold.*

**Consultation Hold**—During a consultation or during transfer to another station, the Line LED will appear at your station as follows:

- Flash rate: 10 impulses per second
- Color: Green
- Other stations with the Line: 1/2 second on—1/2 second off, red

**Exclusive Hold**—When you place an outside call on Exclusive Hold, the Line LED will appear at your station as follows:

- Flash rate: 10 impulses per second
- Color: Green
- Other stations with the Line: Steady, red

**Hold Recall**—When a held call is recalling your station and your station is idle, the Line LED will appear at your station as follows:

- Flash rate: 2 impulses per second for 1 second—10 impulses per second for 1 second
- Color: Green
- Other stations with the Line: Steady, red

**Intercom Call**—While another station is ringing your station, your Intercom LED will appear as follows:

- Flash rate: 10 impulses per second for 1 second—1 second off
- Color: Green

**Busy Station Transfer**—When an outside call is transferred to your station (from a designated station or Auto Attendant) when you are on another call, the Line LED will appear at your station as follows:

- Flash rate: 10 impulses per second
- Color: Green
- Other stations with the Line: Steady, red

#### FEATURE BUTTON LED INDICATIONS

Most of the feature buttons have LEDs, and most of these LEDs flash when activated. Some of these LEDs will also flash when the button is not activated.

#### VOLUME CONTROLS

Your telephone has two **Vol** buttons for controlling speaker and handset volume levels. One of these buttons has a symbol that points up and the other has a symbol that points down. To increase any of the volume levels, press the upward pointing arrow; to decrease any of the volume levels, press the downward pointing arrow.

#### IMPORTANT!

*Either button must be held down for at least 1/8 of a second for a volume change to occur. If either button is continually held down, the volume will continually change about every 1/2 second until a level limit is reached or the button is released.*

#### RING TONE VOLUME (INCOMING HANDSFREE ANSWERBACK)

Adjust the ring tone volume with the procedure in the left-hand column, which also changes the volume level of incoming Handsfree Answerback calls before they are answered by pressing the Intercom button.

#### To Adjust Ring Tone:

1. Ensure that the handset is on the hook.
2. Press and hold down the **Vol** button.

You can adjust the ring tone only if the handset is on the hook and the telephone is in the idle state.

You will hear ring tone as long as you press the button. Press the upward arrow volume button to decrease the volume, or press the downward arrow button to increase the volume.

**STRATA DK DIGITAL TELEPHONE**

**GENERAL INFORMATION**

3. Release the button when the desired ring volume is set.

This procedure will also change the volume level of a caller's voice on Handsfree Answerback calls to your telephone.

1. Ensure that the handset is on-hook.

2. Press the **Intercom** button and dial **6 1 0 2**.

After you press the Intercom button and dial 6 1 0 2, your phone will ring for 15 seconds or until disconnected by pressing the Spkr button.

3. Hold down the **Vol** button until the desired volume is set.

Press the down arrow volume button to decrease the volume, or press the up arrow button to increase the volume. This procedure will also change the volume level of a caller's voice on Handsfree Answerback calls to your telephone.

**INCOMING HANDSFREE ANSWERBACK VOLUME (RING TONE)**

Adjust the volume level of incoming Handsfree Answerback calls before they are answered by pressing the **Vol** button with the procedure in the left-hand column. This procedure will also change the ring tone volume.

**To Adjust Handsfree Incoming Call:**

1. While receiving a handsfree intercom call, press and hold down the **Vol** button.
2. Release the button when the desired volume is set.

Press the down arrow volume button to decrease the volume, or press the up arrow button to increase the volume.

**HANDSET RECEIVER VOLUME**

The procedure in the left-hand column describes how to adjust the volume level of your handset receiver.

**To Adjust Handset Receiver:**

1. While on an off-hook call, press and hold down the **Vol** button.

Press the down arrow volume button to decrease the volume, or press the up arrow button to increase the volume.

**STRATA DK DIGITAL TELEPHONE**

**GENERAL INFORMATION**

2. Release the button when the desired volume is set.

*NOTE: After a call is terminated and the handset is placed on-hook, the handset receiver volume level will return to the original preset level for the next call.*

**SPEAKER VOLUME**

The procedure in the left-hand column explains how to adjust the speaker volume level for calls originated on-hook from the handset, intercom and CO dial tone, Background Music, and Other Announce.

**To Adjust Speaker While Idle:**

1. Press the **Intercom** button.
2. Press and hold down the **Vol** button.
3. Release the button when the desired volume is set.

After you press the Intercom button, you will hear dial tone.

Press the down arrow volume button to decrease the volume, or press the up arrow button to increase the volume.

You can stop the dial tone by pressing the Spkr button.

**To Adjust Speaker While on an On-hook Call:**

1. Press and hold down the **Vol** button.
2. Release the button when the desired volume is set.

Press the down arrow volume button to decrease the volume, or press the up arrow button to increase the volume.

**MUTED TONE BURST VOLUME**

The procedure in the left-hand column describes how to adjust the volume of the muted tone burst sent to your telephone with features, including Busy Override, Do Not Disturb Override, and Transfer with Camp-on.

**STRATA DK DIGITAL TELEPHONE**

**GENERAL INFORMATION**

**To Adjust Muted Tone Burst:**

1. Press the **Intercom** button and dial **6 1 0 1**.
2. Press and hold down the **Vol** button.
3. Release the button when the desired volume is set.

After you dial 6 1 0 1, you will hear the muted tone for 15 seconds or until disconnected by pressing the Spkr button.

Press the down arrow volume button to decrease the volume, or press the up arrow button to increase the volume.

---

**MICROPHONE SENSITIVITY CONTROL**

You can set the sensitivity of the microphone on 2000-series speakerphone models to adjust for the level of room noise.

**HIGH-NOISE SENSITIVITY**

If it is noisy around your station and people are cutting off while talking to you on your speakerphone, set your microphone for high-noise sensitivity.

**To Set for High-noise Sensitivity:**

1. While holding down the **Mic** button, press the up **Vol** button for three seconds.

The Mic LED should flash about six times while setting the sensitivity.

Confirm that the LED flash conforms to the desired mode of operation (Note 2).

**NOTES:**

1. *This procedure can be performed while idle or on a speakerphone call.*
2. *When the microphone is set for high-noise sensitivity, the Mic LED will flash at the in-use rate when the telephone is busy on a speakerphone call.*

**NORMAL SENSITIVITY**

The microphone should be set for normal sensitivity operation when the station is located in a normal office (low-noise level) environment.

**STRATA DK DIGITAL TELEPHONE**

**GENERAL INFORMATION**

**To Set for Normal Sensitivity:**

1. While holding down the **Mic** button, press the down **Vol** button for three seconds.

The Mic LED should flash about six times while setting the sensitivity.

Confirm that the LED flash conforms to the desired mode of operation (Note 2).

**NOTES:**

1. *This procedure can be performed while idle or on a speakerphone call.*
2. *When the microphone is set for normal sensitivity, the Mic LED will be lit steady when the telephone is busy on a speakerphone call.*

---

**HANDSET/HEADSET CALL WAITING TONE OPTION**

Your station will receive one or more call waiting tones when you or is camped-on to your telephone while you are busy on a call. These tones are always sent over the speaker of 2000-series Digital Telephones; however, on 2000-series Speakerphone models, the tones can also be sent to the handset and the headset.

**To Have Tones Sent over the Handset, Headset, and Speaker:**

1. While holding down the **Redial** button, press the up **Vol** button for one second.

This procedure can be performed while either idle or busy on a call.

**To Have Tones Sent over the Speaker Only:**

1. While holding down the **Redial** button, press the down **Vol** button for one second.

This procedure can be performed while either idle or busy on a call.

## ON-HOOK/OFF-HOOK

Some procedures in this user guide instruct you to perform a step while "on-hook" or "off-hook." These terms refer to the position of the handset. "Off-hook" indicates that the handset should be lifted off of the telephone cradle. "On-hook" indicates that the handset should remain in the cradle and should not be lifted.

## Chapter 2

## OUTSIDE CALLS

You can make calls to or receive calls from telephones outside the STRATA DK system.

### To Make an Outgoing Call by Direct Access:

1. Lift the handset.
2. Press any available **Line** button.  
... or ...  
Press any available **Pooled Line Grp** button.
3. Dial a telephone number.
4. Hang up when the call is completed.

If programmed for Automatic Off-hook Selection, your station will go off-hook on a CO or intercom line when you lift the handset.

After you press the Line button, you should hear CO line dial tone. The Line LED will flash green at the in-use rate.

You will hear CO dial tone, and the Pooled Line Grp LED will flash green at the in-use rate.

You will no longer hear dial tone after dialing the first digit of the number, but the LED will continue to flash at the in-use rate.

The LED should turn off.

### To Make an Outgoing Call by Dial Access:

1. Lift the handset.
2. Press the **Intercom** button.
3. Dial a CO line access code.
4. Dial a telephone number.

If programmed for Automatic Off-hook Selection, your station will go off-hook on a CO or intercom line when you lift the handset. If so, skip to Step 3.

After you press the Intercom button, you will hear intercom dial tone. The Intercom LED will flash green at the in-use rate.

CO line access codes are 7 0 1 ~ 7 0 4 (for DK8) and 7 0 1 ~ 7 0 4 (for DK16). With some systems, you may have to dial either the group code (9), Least Cost Routing (LCR) code (9), or a line group code (8 1 ~ 8 8 for DK8, 8 1 ~ 8 8 for DK16), instead of a CO line access code.

The LED will continue to flash at the in-use rate.

**STRATA DK DIGITAL TELEPHONE**

**FEATURE OPERATION**

**To Answer a Call on a CO Line Button:**

1. When your telephone rings, press the **Line** button and lift the handset.

The status of the Line LED will change from the red incoming call rate to the green in-use rate when you press the button. (If the line is transferred to you, the Line LED will flash green—instead of red—while your station is ringing.)

**To Receive a Call on a Pooled Line Button:**

1. When your telephone rings, press the **Pooled Line Grp** button or lift the handset.

The status of the LED associated with the Pooled Line Grp button will change from the red incoming call rate to the green in-use rate when you press the button or lift the handset.

**ON-HOOK DIALING**

You can dial calls without lifting the handset. You must lift the handset to converse, unless your telephone is a full speakerphone.

**OUTSIDE CALLS**

You can dial an outside telephone number without lifting the handset.

**To Dial an Outside Call While On-hook:**

1. Press any available **Line** button or **Pooled Line Grp** button.  
... or ...  
Press the **Intercom** button, then dial a CO line or a line group access code.
2. Dial a telephone number.
3. Lift the handset when the called party answers.
4. Hang up when the call is completed.

You will hear CO line dial tone when you press the button, and the Line or Pooled Line Grp LED will flash green at the in-use rate.

CO line access codes are 7 0 1 ~ 7 0 4 (for DK8) and 7 0 1 ~ 7 0 8 (for DK16) and line group codes are 8 1 ~ 8 4 (for DK8) and 8 1 ~ 8 8 (for DK16). Some systems may require that you dial either the general group code (9) or Least Cost Routing code (9), instead.

The LED will continue to flash green.

The LED will continue to flash green. You do not have to lift the handset if you have a full speakerphone.

The LED will turn off. Press the Spkr button to disconnect the call if you did not lift the handset.

**STRATA DK DIGITAL TELEPHONE**

**INTERCOM CALL:**

You can dial a station

**To Dial an Intercom Call While On-hook:**

1. Press the **Intercom** button.
2. Dial a station number.

You will hear dial tone and the Line LED will flash green at the in-use rate.

If the called station is busy, you will hear busy tone and should dial a station number using the method, Tone 9.

- If the system is programmed for busy tones and you dial a station number using the method, Voice 9.
- To leave a Message.

If you receive busy tone, you can:

- To set Automatic Answer.
- To activate Busy Hook Call Answer.
- To activate OC (Outgoing Call) if the system is equipped for OC.
- Dial 3 to enter the programmable menu.
- To leave a Message.

3. Lift the handset when the called station is answered.
4. Hang up when the call is completed.

The LED will continue to flash green while the telephone is in the on-hook state because the character is not yet dialed.

The LED will turn off if you did not lift the handset.

**STRATA DK DIGITAL TELEPHONE**

**FEATURE OPERATION**

**GROUP LISTENING**

This feature enables you to set your telephone so that you and people near your telephone can hear the distant party over the speaker, but the distant party will not be able to hear you.

**To Activate Group Listening:**

1. Establish an off-hook call with a distant party.
2. Hold down the **Spkr** button.
3. When you want to talk to the distant party, release the **Spkr** button.

The Spkr LED will light red and you will be able to hear the distant party on the telephone speaker. The distant party will not be able to hear you.

The handset is activated. Continue to operate in an alternate fashion as desired.

**AUTOMATIC OFF-HOOK SELECTION**

Automatic Off-hook Selection allows you to access intercom or a specific line or line group just by lifting the handset or pressing the Spkr button. This is an optional feature enabled in system programming.

**To Make a Call:**

1. Lift the handset or press the **Spkr** button.
2. Dial a telephone number, and proceed with your call.

You will be connected to the option programmed.

If you hear silence, you must press the Intercom button or a Line or Pooled Line Grp button before dialing the telephone number.

*NOTE: If your station is programmed with Ringing Line Preference, you can answer a line ringing your station by lifting the handset or pressing the Spkr button.*

**STRATA DK DIGITAL TELEPHONE**

**FEATURE OPERATION**

**REPEAT LAST NUMBER DIALED**

This feature enables you to automatically redial the last number (line or intercom) called by pressing the Redial button.

**To Redial the Last Number Dialed:**

1. Lift the handset.
2. Press any available **Line** button or **Intercom** button.
3. Press the **Redial** button, and proceed with your call.

You will hear dial tone after you press the button.

The last telephone number you dialed will be automatically redialed.

**AUTOMATIC BUSY REDIAL**

After reaching a busy outside number, you can activate Automatic Busy Redial (ABR) so that the STRATA DK system will automatically redial that number for you at regular intervals. ABR is an optional feature that you may not have.

**To Activate Automatic Busy (ABR) Redial:**

1. While listening to busy tone, press the **Auto Busy Redial** button.  
... or ...  
While listening to busy tone, press the **Cnf/Trn** button and dial **4 4**.
2. Hang up or press the **Spkr** button.
3. The system will redial the number.

The Auto Busy Redial LED will flash red when you press the button.

You will hear confirmation tone after you press the button.

Hang up if the call was established off-hook; press the Spkr button if the call was established on-hook.

The system will redial every 30 or 60 seconds (based on system programming), up to 15 times (See Notes 1 and 2).

**STRATA DK DIGITAL TELEPHONE**

**FEATURE OPERATION**

- Your telephone will receive ring tone when ABR dials the number and it is available.
- Lift the handset or press the **Spkr** button and wait for the party to answer.

The Line—or Intercom—and Spkr LEDs will flash green. The called telephone number will ring.

If you fail to pick up the handset or press the Spkr button within 30 seconds after a connection is made, you will hear a muted ring for another 30 seconds, then the call will disconnect.

**NOTES:**

- ABR will not be attempted while your station is busy, but will continue to time-out.*
- With each attempt:*
  - *The Line—or Intercom—and Spkr LEDs blink when the line is seized.*
  - *Dial tone is heard via the speaker.*
  - *The telephone number is redialed.*
  - *If busy, ABR will reset and try again.*

**To Cancel Automatic Busy (ABR) Redial:**

- Press the **Auto Busy Redial** button.  
... or ...  
Press the **Intercom** button and dial **4 4**.

**SPEED DIAL**

Speed Dial enables you to call a telephone number with a brief access code or an optional feature button. There are two types of Speed Dial numbers. Station Speed Dial numbers are assigned by individual station users to their own station, and can only be dialed at their station. System Speed Dial numbers can only be assigned from Station 10 (typically the operator's or system administrator's telephone), but can be used by other stations.

Your station will time out to the idle mode if the following storage procedures are not completed within one or three minutes. The time is set in system programming.

**STRATA DK DIGITAL TELEPHONE**

**FEATURE OPERATION**

**STATION SPEED DIAL STORAGE**

You can store personal telephone numbers on either the Speed Dial buttons or access codes. You can call the telephone number by pressing the button or dialing the access code.

**To Store a Station Speed Dial Number:**

- Do Not Lift the handset.
- Press the **Redial** button.
- Press the **SD** button you wish to store the telephone number on.  
... or ...  
Press the **Speed Dial** button and enter the code (1 0 - 4 9) that you want to store the telephone number in.

SD buttons are assigned in system programming. If your telephone does not have SD buttons, use access codes, instead.

The \* button can be used if your telephone does not have a Speed Dial button.

Station Speed Dial number access codes are 1 0 - 4 9, as provided in Appendix B to record Speed Dial codes and numbers.

- Enter the telephone number.

You can enter up to 20 digits. See "Speed Dial Numbers" in this section for instructions on storing additional digits.

It may be necessary to insert a pause or flash signal in dialing. See "Speed Dial Pause and Flash Storage" later in this section for details.

- Press the **Redial** button.

The number will be stored and will be dialed when it is called by pressing or the Speed Dial access code is dialed.

Repeat this procedure to replace the stored telephone number with new ones. To clear a Speed Dial entry, repeat the preceding procedure, skipping Step 4.

**SYSTEM SPEED DIAL STORAGE**

Only Station 10 (typically the operator's or system administrator's telephone) can store System Speed Dial numbers, although they are available at all stations for dialing. System Speed Dial buttons can be assigned by stations in system programming.

**STRATA DK DIGITAL TELEPHONE**

**FEATURE OPERATION**

**To Store a System Speed Dial Number at Station 10:**

1. Do Not Lift the handset.
2. Press the **Redial** button, then the **Speed Dial** button.
3. Enter the Speed Dial code (6 0 ~ 9 9) where you want to store the telephone number.
4. Enter the telephone number.
5. Press the **Redial** button.

The \* button can be used if your telephone does not have the Speed Dial button.

System Speed Dial number access codes are 6 0 ~ 9 9. (Space is provided in Appendix B to record Speed Dial codes and their numbers.) System Speed Dial buttons associated with the codes are assigned to stations in system programming.

You can store up to 20 digits. See "Speed Dial Number Linking" later in this section for instructions on storing additional digits.

It may be necessary to insert a pause or flash signal in the number. See "Speed Dial Pause and Flash Storage" later in this section for more details.

The number will be stored and will be dialed when the Speed Dial access code is dialed at a station, or when an SD button associated with the code is pressed.

Repeat this procedure to replace the stored telephone numbers with new ones. To clear a Speed Dial entry, repeat the preceding procedure, skipping Step 4.

**SPEED DIAL PAUSE AND FLASH STORAGE**

Some Speed Dial numbers may require that a pause (long or regular) or hookflash be included in the number. For example, you may have to enter a pause at the beginning of a Speed Dial number to allow for dial tone delay.

**To Store a Hookflash:**

1. Press the **Flash** button.

If your telephone does not have a Flash button, enter the hookflash dial code, "Cnt/Trn 4 5," where upon the flash should be stored in the Speed Dial number string.

**STRATA DK DIGITAL TELEPHONE**

**FEATURE OPERATION**

**To Store a Regular Pause:**

1. Press the **Spd Dial Pause** button.

This pause—which will be one-and-a-half or three seconds, depending on system programming—can be entered anywhere in the Speed Dial number. The Spd Dial Pause button must be programmed in the system programming to allow the telephone to store pauses.

**To Store a Long Pause:**

1. Press the **Spd Dial Long Pause** button.

This pause, which is 10 seconds, can be entered anywhere in the Speed Dial number.

*NOTE: The Flash button will store a pause if the Spd Dial Pause button is not programmed on a flexible button. The Flash button will not store a flash signal only if the Spd Dial Pause button is on the telephone.*

**SPEED DIAL NUMBER LINKING**

You can link any of your personally assigned Speed Dial numbers (1 0 ~ 4 9) to System Speed Dial codes 9 0 ~ 9 9 or to any of the Speed Dial buttons associated with these 10 codes. Station 10 can be used to link System Speed Dial codes 6 0 ~ 8 9 to codes 9 0 ~ 9 9. This allows up to 37 digits to be stored under one System Speed Dial button or code.

The number stored in location 9 0 ~ 9 9 will dial out first, followed by the number linked to 9 0 ~ 9 9. Typically, a company's special care telephone numbers are stored in locations 9 0 ~ 9 9.

**To Link a Number:**

1. Press the **Redial** button.
2. Press a **SD** button.  
... or ...  
Press the **Speed Dial** button and enter a two-digit Speed Dial access code.
3. Press the **Speed Dial** button.

The \* button can be used if your telephone does not have the Speed Dial button.

Station users may enter Station Speed Dial codes (1 0 ~ 4 9) and the SD button can be used to enter System Speed Dial codes 6 0 ~ 8 9.

The \* button can be used if your telephone does not have the Speed Dial button.



**STRATA DK DIGITAL TELEPHONE**

**FEATURE OPERATION**

4. Enter the two-digit code to which the number will be linked (**9 0 ~ 9 9**).
5. Enter the number to be linked. You may enter up to 17 digits. (There is space provided in Appendix B to record Speed Dial codes and their numbers.)
6. Press the **Redial** button. The number will be stored and will be dialed out when the optional linked System SD button is pressed or the linked System Speed Dial access code is dialed.

**CALLING SYSTEM OR STATION SPEED DIAL NUMBERS**

You can call Speed Dial numbers with the touch of a button or by dialing a brief access code. Speed Dial buttons are assigned to stations in system programming.

**To Call with a Speed Dial button:**

1. Access a CO line. You can access a CO line by pressing a Line or Pooled Line Grp button, or by dialing an access code (7 0 1 ~ 7 0 4 for DK8, 7 0 1 ~ 7 0 8 for DK16 for a line number; 8 1 ~ 8 4 for DK8, 8 1 ~ 8 8 for DK16 for a line group; and 9 for the general group or Least Cost Routing).
2. Press a **SD** button. The system will dial the telephone number assigned to the button.

**To Call with a Speed Dial Access Code:**

1. Access a CO line. You can access a CO line by pressing a Line or Pooled Line Grp button, or by dialing an access code (7 0 1 ~ 7 0 4 for DK8, 7 0 1 ~ 7 0 8 for DK16 for a line number; 8 1 ~ 8 4 for DK8, 8 1 ~ 8 8 for DK16 for a line group; and 9 for the general group or Least Cost Routing).
2. Press the **Speed Dial** button. The \* button can be used if your telephone does not have the Speed Dial button.
3. Dial the 2-digit Speed Dial access code. Station Speed Dial codes are 1 0 ~ 4 9, and System Speed Dial codes are 6 0 ~ 9 9.  
  
The system will automatically dial the telephone number assigned to the dialed code.

**STRATA DK DIGITAL TELEPHONE**

**FEATURE OPERATION**

**CHAIN DIALING SPEED DIAL NUMBERS**

You can call two or more Speed Dial numbers during one call. This feature enables you, for example, to add additional parties (conference calling) to your conversation with Speed Dialing.

**To Chain Dial Speed Dial Numbers:**

1. Access a CO line.
2. Press the **SD** button of the telephone number to be dialed.  
... or ...  
Press the **Speed Dial** button and dial the Speed Dial code for the telephone number to be dialed.
3. Repeat Step 2 to dial another telephone number.

You can access a CO line by pressing a Line or Pooled Line Grp button, or by dialing an access code (7 0 1 ~ 7 0 4 for DK8, 7 0 1 ~ 7 0 8 for DK16 for a line number; 8 1 ~ 8 4 for DK8, 8 1 ~ 8 8 for DK16 for a line group; and 9 for the general group or Least Cost Routing).

The \* button can be used if your telephone does not have a Speed Dial button.

Station Speed Dial codes are 1 0 ~ 4 9, and System Speed Dial codes are 6 0 ~ 9 9.

**SAVED NUMBER REDIAL**

This feature enables you to store a dialed telephone or station number, then redial that number with the touch of a button. Your telephone must be assigned with the Save Last Number button in system programming.

**To Save a Telephone Number:**

1. While on a call that you dialed, press the **Save Last Number** button. You can press the button anytime after you have dialed the telephone number, but you must do it before you press the disconnect the call.

**STRATA DK DIGITAL TELEPHONE**

**FEATURE OPERATION**

**To Call a Saved Telephone Number:**

1. Access a CO line.
2. Press the **Save Last Number** button.

You can access a CO line by pressing a Line or Pooled Line Grp button, or by dialing an access code (7 0 1 - 7 0 4 for DK8, 7 0 1 - 7 0 8 for DK16 for a line number; 8 1 - 8 4 for DK8, 8 1 - 8 8 for DK16 for a line group; and 9 for the general group or Least Cost Routing).

The system will automatically dial the "saved" number.

**DTMF TONE DIALING WITH \* AND #**

You may have to send \* and # Dual-tone Multi-frequency (DTMF) tones to some devices or services, such as a voice mail device or computer output service. If you do not have the Speed Dial button on your telephone, you must first dial an access code to enable these tones to be transmitted. DTMF tones are automatically enabled on stations with the Speed Dial button.

**To Output \* and # DTMF Tones:**

1. While on an outside call, press the \* button, then the # button, if you do not have the **Speed Dial** button.

You will now be able to output \* and # DTMF tones, as well as digits 0 - 9.

This feature disables the Speed Dial feature. Speed Dial will be restored when you complete the call or place it on hold.

**TONE/PULSE DIALING**

With some older Central Offices, you may have to make calls using rotary dial pulses on CO lines. To access remote equipment (such as an answering machine) requiring Dual-tone Multi-frequency (DTMF) tones while on these lines, you must set your phone for tone dialing after you have dialed the telephone number. Your telephone must have a Tone Dial Select button assigned in system programming to access this feature.

**STRATA DK DIGITAL TELEPHONE**

**FEATURE OPERATION**

**To Change to Tone Dialing:**

1. Dial a telephone number on a CO line programmed for rotary dial pulses.
2. While the call is in progress, press the **Tone Dial Select** button.

Although the CO line is programmed for rotary dial pulses, you can dial a CO line and dial the telephone number like any other call. See this user guide.

After you press the button, the Tone Dial Select LED will light up, and you will be able to send DTMF tones with your dialpad.

If the LED is off, tone dialing is not selected and you will not be able to send DTMF tones.

*NOTE: When originating or receiving a new CO line call, the system will automatically place the line in the dial pulse mode.*

**PRIVACY OVERRIDE**

This optional feature allows you to enter an established call on a common CO line button. Up to two station users may enter an established CO line-to-station call (allowing up to three stations to be connected to the CO line). To access this feature, your station must be assigned to Privacy Override in system programming, or the station that is currently connected to the CO line must be in the Privacy Release mode.

**To Override a Call:**

1. Press a busy **Line** button.

You will now be connected to the CO line, and will be able to participate in the conversation.

An optional tone signal may be heard by the connected party when you enter the conversation.

*NOTE: Station users with a Privacy Release button can allow stations to enter their conversations on common Line buttons, even if the station entering the conversation is not programmed for Privacy Override.*

## PRIVACY BUTTON

This option blocks a user at a station programmed with Privacy Override from entering a CO line conversation by pressing a common CO line button. Your station must be assigned with the Privacy on Line button in system programming to activate this feature, which will not block Busy Override or Executive Override. Busy and Executive Override are described later in this guide.

### To Make All CO Lines on Your Station Private:

1. Press the **Privacy on Line** button. After you press the button, the Privacy on Line LED will light steady red, and station users will not be able to enter CO line calls on your station with Privacy Override.

### To Cancel Privacy:

1. Press the **Privacy on Line** button again. The Privacy on Line LED will turn off, and station users will now be able to enter CO line calls on your station with Privacy Override.

## PRIVACY RELEASE

If you press the optional Privacy Release button, any other station user can enter your call on a private common CO line button just by pressing the Line button on their telephone. Your station must be assigned with the Privacy Release button in system programming to activate this feature.

### To Activate Privacy Release:

1. While on a CO line call, press the **Privacy Release** button. After you press the button, the Privacy Release LED will light steady red, and station users should be able to enter your calls by pressing a common CO line button.

You must be on a CO line call to activate this feature.

### To Deactivate Privacy Release while on a CO Line Call:

1. Press the **Privacy Release** button again. The Privacy Release LED will turn off, and station users without Privacy Override will not be able to enter your calls by pressing a common CO line button.

If you do not deactivate Privacy Release while on the call, it will deactivate when you hang up.

*NOTE: Private CO lines deny station users access to busy override on CO line buttons.*

## INTERCOM CALLS

You can make calls to and receive calls from other stations in the system.

### To Make an Intercom Call:

1. Lift the handset.
2. Press the **Intercom** button.
3. Dial a station number.

You will hear silence after you lift the handset, unless your system has been programmed for Automatic Off-hook Selection.

If Automatic Off-hook Selection provides CO line dial tone when you lift the handset, continue with Step 2; if you hear intercom dial tone, continue with Step 3.

After you press the button, you will hear intercom dial tone and the Intercom LED will flash green at the In-use rate. Skip Step 2 if the system provides intercom dial tone when you lift the handset.

If the called station is idle:

- If the system is set for Voice First Signaling, you will hear a single tone and should then make a voice announcement. (After dialing the station number, you can dial 1 to change to the other signaling method, Tone Signaling.)
- If the system is set for Tone Signaling, you will hear repeated ring tones and you should wait for the call to be answered. (After dialing the station number, you can dial 1 to change to the other signaling method, Voice First Signaling.)
- To leave a Message Waiting Indication at the called station, press the **Message Waiting** button.

If you receive busy tone:

- To set Automatic Call Back (ACB), dial 4 .
- To activate Busy Override if the called station is not equipped for Off-hook Call Announce (OCA), dial 2.
- To activate OCA: With Voice First Signaling and the called station is equipped for OCA, dial 2. With Tone Signaling and the called station is equipped for OCA, dial 21.
- Dial 3 to enter the station's conversation (Executive Override, system programmable option).
- To leave a Message Waiting Indication at the called station, dial 7.

**To Receive an Intercom Call (Voice First Signaling):**

1. You will hear a single long tone, followed by the caller's voice.
2. Lift the handset.

The Intercom LED will flash green at the incoming call rate.

If the call was made with Tone signaling instead of Voice First Signaling, your phone would ring.

The Intercom LED will flash green at the in-use rate after you lift the handset.

**STONE/VOICE FIRST SIGNALING**

Your STRATA DK system may be set for Tone Signaling or Voice First Signaling as the standard intercom call signaling method. The Tone Signal consists of successive ring tones, while the Voice First Signal consists of a tone burst followed by the caller's voice. You can change to the alternate signaling method on a call-by-call basis.

**To Change the Signaling Method:**

1. Call another station via intercom.
2. Dial **1**.
3. Speak to the party when the call is answered.

Depending on the system signaling method, the following will happen:

- If Tone Signaling, you will hear a ring tone (one second) every four seconds.
- If set for Voice First Signaling, you will hear a tone burst and then you will be able to converse.

After you dial 1, the other method will be activated.

**HANDSFREE ANSWERBACK**

You can answer intercom calls without lifting the handset

**To Receive a Handsfree Intercom Call:**

1. You will hear a single long tone, followed by the caller's voice.
2. Don't lift the handset; speak toward the telephone in a normal voice level.

The Intercom LED will flash green at the incoming call rate. The Mic LED will light steady red, indicating your microphone is active. The Spkr LED will flash red.

If you have a speakerphone, you will have better performance. Press the Intercom button.

*NOTE: The Intercom button must be pressed (or the handset taken off-hook) before placing an intercom call on hold.*

**HANDSFREE ANSWERBACK VOLUME CONTROL**

You can control the volume of the Handsfree Answerback call.

**To Change the Volume while on the Call:**

1. Press the up or down **Vol** button until the desired level is set.

You can also control this volume while in the idle state. Press the up or down Vol button and hear ring tone. Continue pressing the button until the desired volume is set. Adjusting this volume will not change ring tone volume.

**MICROPHONE CUT-OFF**

Microphone Cut-off prevents callers from monitoring the operation of your telephone. Your station must be assigned with the Microphone Cut-off button in system programming to activate this feature.

**To Turn Off the Microphone:**

1. Press the **Microphn Cut-off** button.

After you press the button, the Microphn Cut-off LED will light steady red and the Mic and Spkr LEDs will not turn on when your telephone is called.

**STRATA DK DIGITAL TELEPHONE**

**FEATURE OPERATION**

**To Turn the Microphone On:**

1. Press the **Microphn Cut-off** button again.

The Microphn Cut-off LED will turn off.

**OFF-HOOK CALL ANNOUNCE (OCA)**

This feature allows you to call and speak through the speaker of an off-hook, busy digital or electronic telephone. The called telephone must be equipped for OCA capability.

**To Make an OCA Call with Voice First Signaling:**

1. Lift the handset.
2. Call the desired station.
3. Speak to the called party or dial **2** if busy.

You will hear a single tone and will be able to talk to the station if your station is programmed for automatic OCA operation.

If your station is not programmed for automatic OCA operation and if you hear busy tone, you must dial 2 to speak to the called station.

**To Make an OCA Call with Tone Signaling:**

1. Lift the handset and call the desired station.
2. If you receive busy tone, dial **2 1**.

Speak to the called station after dialing 2 1.

**FORCED DISCONNECT**

You can disconnect an OCA call made to your station.

**To Force a Disconnect:**

1. Press the **Spkr** button.

The OCA call will be disconnected after you press the button.

**STRATA DK DIGITAL TELEPHONE**

**FEATURE OPERATION**

**OCA VOLUME CONTROL**

You can control the volume of OCA calls to your station when the station is idle. It is not possible to change the OCA volume when the telephone is in use off-hook.

**To Change the Volume while Idle:**

1. Press the **Intercom** button and then the up or down **Vol** button until the desired volume is set.

You will hear intercom tone. The volume level of OCA calls to your station will be the same as the intercom tone level that you set in this procedure. The intercom tone will stop after 15 seconds if the **Spkr** button is pressed.

**NOTES:**

1. Stations in the Do Not Disturb mode cannot receive OCA calls.
2. The Mic and Microphn Cut-off buttons can prevent intercom tone from listening to your conversation.
3. This procedure also sets the volume level for station to receive music and speaker intercom tone.

**CALL TRANSFER WITH CAMP-ON**

You can transfer calls to idle or busy stations.

*NOTE: You cannot transfer (or camp-on) to stations that are in Do Not Disturb (DND) mode.*

**To Transfer a Call (Voice First Signaling):**

1. While on an outside call, press the **Cnf/Trn** button.
2. Dial the station number to which the call will be transferred.
3. Announce the call if the called station is idle, then hang up.

After you press the button, the Line LED will flash green at the conference rate, and the Intercom LED will flash green at the conference rate. You will hear intercom dial tone.

You will hear a single tone. (If the call was made with tone signaling instead of Voice First Signaling, you would hear ringing tone.)

**STRATA DK DIGITAL TELEPHONE**

**FEATURE OPERATION**

The Intercom LED will turn off, the Line LED will begin to flash green at the on-hold rate, and the CO line will ring the called station. (See the Note that follows.)

The Line LED will change to steady red when the called station connects with the transferred call.

If the called station user fails to answer the call, you will receive a recall ring (when your station is idle) after a time set in system programming.

... or ...  
Hang up if the called station is busy.

The Intercom LED will turn off, and the Line LED will begin to flash green at the on-hold rate. The CO line will camp on to the called station (see the Note that follows), and the called station will receive a warning tone.

The Line LED will change to steady red when the called station connects with the transferred call.

You will receive a recall ring when your station is idle and camp-on will be cancelled if the called station user fails to answer within a predetermined time. Answer the recall and inform the caller of the situation, and repeat the procedure if necessary.

*NOTE: You may reconnect to a transferred line (anytime before it is answered) by pressing the appropriate Line button, or by dialing Intercom 4 2 if the Line button does not appear on your telephone.*

**ANSWERING A TRANSFERRED CALL**

You can answer a call that is transferred to your station, whether you are idle or busy on another call.

**To Answer While Idle (Voice First Signaling):**

1. You will hear a single long tone, followed by an announcement.
2. Acknowledge the announcement.
3. When the transferring station hangs up, you will hear a ringing tone.

The Intercom LED will flash green at the incoming call rate.

The Line LED will flash at the incoming call rate.

**STRATA DK DIGITAL TELEPHONE**

**FEATURE OPERATION**

4. Press the appropriate **Line** button.

After you press the button, the Line LED will flash green at the on-hold rate, and you will be connected to the call.

*NOTE: If your telephone has been assigned with the Auto Hold feature, you may press the **Spkr** button on the handset instead of pressing the Line button.*

**To Answer While Idle (Tone Signaling):**

1. You will hear intercom ringing.
2. Lift the handset or press the **Spkr** button.
3. Speak to the transferring station.
4. You will be connected to the outside call when the transferring station hangs up.

The Intercom LED will flash green at the incoming call rate.

After you press the button, the Intercom LED will flash at the incoming call rate.

The Intercom LED will turn off, and the Line LED will flash green at the in-use rate when the station hangs up.

**To Answer While Busy:**

1. You will hear a one-second warning tone.
2. You have several choices:  
Press the **Line** button.

The outside call is camped on to your station, and the Line LED will flash green at the on-hold rate.

... or ...

After you press the button, the existing call will be terminated and you will be connected to the transferred call. The Line LED will flash green at the in-use rate.

Hang up.

The existing call will be terminated. The camped-on line will ring your telephone, and the Line LED will flash red at the incoming call rate.

... then ...

Press the **Line** button or lift the handset.

After you press the button, you will be connected to the transferred call and the Line LED will flash green at the in-use rate.

... or ...

Press the **Hold** button.

The existing call will be put on hold. The camped-on line will ring your station, and the Line LED will flash red at the incoming call rate.

... then ...

Press the **Line** button.

You will be connected to the transferred call, and the Line LED will flash green at the in-use rate.

## CONFERENCE CALLS

This feature enables you to add other parties to an existing call. (If you have an LCD telephone, you can use *Soft Keys* to make a conference call. See the LCD user guide for details.)

### CONFERENCE WITH STATIONS AND CO LINES

Conference Calls can be up to two stations and two CO lines, up to three stations and one CO line or up to four stations.

*NOTE: The STRATA DK8 supports two simultaneous conferences. If a four-party conference is in progress, the second conference may contain three parties maximum.*

#### To Add a Second CO Line:

1. While on a CO line call, press the **Cnf/Trn** button.
2. Access a second CO line and dial the next telephone number.
3. Press the **Cnf/Trn** button after the party answers.

After you press the button, you will hear intercom dial tone.

The Line LED will flash green at the conference rate if the call is on a Line button, and the Intercom LED will flash green at the in-use rate.

You can access a CO line by pressing a Line or Pooled Line Grp button, or by dialing an access code (7 0 1 ~ 7 0 4 for DK8, 7 0 1 ~ 7 0 8 for DK16 for a line number; 8 1 ~ 8 4 for DK8, 8 1 ~ 8 8 for DK16 for a line group; and 9 for the general group or Least Cost Routing).

If you receive a busy tone or no answer, return to the original connection by pressing the original Line button, or hang up and the original connection will recall you immediately.

Both Line LEDs will flash green at the in-use rate.

All parties will be conferenced. You may add one more station to a two-CO line conference.

#### To Add a Station to a CO Line Call:

1. Press the **Cnf/Trn** button.

After you press the button, you will hear intercom dial tone.

The Intercom LED will flash green at the in-use rate; and the Line LED will flash green at the conference rate, if the CO line call was established on a Line button.

2. Dial the number of the station to be added.
3. Press the **Cnf/Trn** button after the party answers.
4. Repeat to add another party.

If you receive a busy tone or no answer, return to the original connection by pressing the **Cnf/Trn** button.

All parties will be conferenced.

The Line LED will flash green at the in-use rate if the CO line call was established on a Line button.

Up to three stations (including your own) may conference with one CO line.

### CONFERENCE WITH STATIONS ONLY

As many as four stations may be conferenced on one intercom line.

#### To Conference with Stations Only:

1. While on a station call, press the **Cnf/Trn** button.
2. Dial a station number.
3. Press the **Cnf/Trn** button after the party answers.
4. To add another station, repeat Steps 1 ~ 3.

After you press the button, you will hear intercom dial tone. The Intercom LED will flash green at the conference rate.

Wait for the called station to answer.

The Intercom LED will flash green at the in-use rate, and all parties will be conferenced.

## CALL FORWARD

You can set your station with a variety of Call Forward modes.

**STRATA DK DIGITAL TELEPHONE**

**FEATURE OPERATION**

*NOTE: If Call Forward is set:*

- *CO lines that ring your station only will forward—CO lines that ring more than one station will not forward.*
- *CO line calls transferred to your station will forward.*
- *Intercom calls will forward (handsfree calls optionally may or may not).*
- *Call Forward has priority over the Station Hunt feature.*
- *Call Forward must be set before the call is received.*
- *Call Forward can be set with the touch of one button. See "User Programmable Feature Buttons" later in this chapter.*

**CALL FORWARD-ALL CALLS**

If your station is idle or busy and has this feature activated, all calls to it will forward immediately. The station will not ring.

**To Set Call Forward-All Calls:**

1. Press the **Call Frwd All Calls** button.  
... or ...  
Press the **Intercom** button, then dial **6 0 1**.  
The Call Frwd All Calls LED will flash red.  
You will hear confirmation tone.
2. Enter the station number to which calls will forward.  
You will hear confirmation tone if 6 0 1 was dialed in Step 1.
3. Press the **Call Frwd All Calls** button or the **Spkr** button.  
The Call Frwd All Calls LED will become steady red, and calls will forward to the stored station number.

**To Cancel:**

1. Press the **Call Frwd All Calls** button.  
... or ...  
Press the **Intercom** button, dial **6 0 1**, then press the **Spkr** button.  
The Call Frwd All Calls LED will turn off.  
You will hear confirmation tone.

**STRATA DK DIGITAL TELEPHONE**

**FEATURE OPERATION**

**CALL FORWARD-BUSY**

Calls to your telephone while you are busy on another call will ring. Not Disturb mode will forward immediately if this feature is set. Calls will ring as normal if your telephone is idle.

**To Set Call Forward-Busy:**

1. Press the **Call Frwd Busy** button.  
... or ...  
Press the **Intercom** button, then dial **6 0 2**.  
The Call Frwd Busy LED will flash red.  
You will hear confirmation tone.
2. Enter the station number to which calls will forward.  
You will hear confirmation tone if 6 0 2 was dialed in Step 1.
3. Press the **Call Frwd Busy** button or the **Spkr** button.  
The Call Frwd Busy LED will become steady red, and calls will ring to the stored station number.

**To Cancel:**

1. Press the **Call Frwd Busy** button.  
... or ...  
Press the **Intercom** button, dial **6 0 2**, then press the **Spkr** button.  
The Call Frwd Busy LED will turn off.  
You will hear confirmation tone.

**CALL FORWARD-NO ANSWER**

All calls to your station when set with this feature will forward to the selected station if you fail to answer within 12 seconds or time-out, whichever occurs first.

*NOTE: Your station can be assigned in system programming not to forward Forward-No Answer when receiving Voice First (handsfree) calls. Callers can activate Call Forward-No Answer by dialing 1 during their wait announcement.*



**STRATA DK DIGITAL TELEPHONE**

**FEATURE OPERATION**

**To Set Call Forward-No Answer:**

1. Press the **Call Frwd No Answer** button.  
... or ...  
Press the **Intercom** button, then dial **6 0 3**.  
The Call Frwd No Answer LED will flash red.  
You will hear confirmation tone.
2. Enter the station number to which calls will forward.  
You will hear confirmation tone if 6 0 3 was dialed in Step 1.
3. Press the **Call Frwd No Answer** button, or the **Spkr** button.  
The Call Frwd No Answer LED will become steady red, and calls will forward to the stored station number.

**To Cancel:**

1. Press the **Call Frwd No Answer** button.  
... or ...  
Press the **Intercom** button, dial **6 0 3**, then press the **Intercom** button.  
The Call Frwd No Answer LED will turn off.  
You will hear confirmation tone.

**CALL FORWARD-BUSY/NO ANSWER**

All calls to your station set with this feature will forward immediately to a selected station whenever you are busy on another call or in the Do Not Disturb mode. Calls will also forward if you do not answer the call within 12 seconds or three rings, whichever occurs first.

*NOTE: Your station can be assigned in system programming not to Call Forward-No Answer when receiving Voice First (handsfree) calls. Callers can activate Call Forward-No Answer by dialing 1 during their voice announcement.*

**STRATA DK DIGITAL TELEPHONE**

**FEATURE OPERATION**

**To Set Call Forward-Busy/No Answer:**

1. Press the **Call Frwd Busy/NAns** button.  
... or ...  
Press the **Intercom** button, then dial **6 0 4**.  
The Call Frwd Busy/NAns LED will flash red.  
You will hear confirmation tone.
2. Enter the station number to which calls will forward.  
You will hear confirmation tone if 6 0 4 was dialed in Step 1.
3. Press the **Call Frwd Busy/NAns** button, or press the **Spkr** button.  
The Call Frwd Busy/NAns LED will become steady red, and calls will forward to the stored station number.

**To Cancel:**

1. Press the **Call Frwd Busy/NAns** button.  
... or ...  
Press the **Intercom** button, dial **6 0 4**, then press the **Spkr** button.  
The Call Frwd Busy/NAns LED will turn off.  
You will hear confirmation tone.

**CALL FORWARD-FIXED**

All intercom and CO line calls to your station will forward immediately to a station set in system programming if you activate this feature. Your station must be assigned with the "Call Forward to \_\_\_\_" button in system programming to activate this feature.

**To Activate Call Forward-Fixed:**

1. Press the **Call Frwd to: \_\_\_\_** button.  
After you press this button, the "Call Frwd to: \_\_\_\_" LED will begin to flash red, and all calls will forward to a station or voice mail device set in system programming.

**STRATA DK DIGITAL TELEPHONE**

**FEATURE OPERATION**

**To Cancel:**

1. Press the **Call Frwd to:** button.

The "Call Frwd to:\_\_\_\_" LED will turn off.

**CALL HOLD**

You can place intercom and CO line calls on hold.

**To Hold a Call that Appears on a CO or Intercom Button:**

1. While on a CO line or intercom call, press the **Hold** button.

After you press the button, the Line or Intercom LED will flash green at the on-hold rate.

You will hear a recall tone (when your station is idle) if you do not retrieve the held call before a time set in system programming.

The call may be released automatically if the held party hangs up and the CO provides a hold-release signal.

To place a Handsfree Answerback call on hold you must first lift the handset or press the Intercom button.

*NOTE: If your station is programmed with Automatic Hold, an existing call will automatically be placed on hold if you answer or make another call. You will not have to press the Hold button. (See Automatic Hold later in this guide.)*

**To Retrieve the Call:**

1. Press the **Line** button or the **Intercom** button which is on hold.

The Line or Intercom LED will flash green at the in-use rate.

**CALL PARK**

When your telephone does not have a Line button for a particular CO line, you can dial an access code to place a call on that line on hold (park) so that you can place a second call. You can also park an intercom call.

**STRATA DK DIGITAL TELEPHONE**

**FEATURE OPERATION**

**To Park a Call and Place another Call:**

1. While on a call, press the **Cnf/Trn** button, then dial **4 1**.
2. Press the **Intercom** button or a **Line** button; then dial the desired number.
3. Hang up or press the **Spkr** button when the call is completed.

The call will be placed on hold/park after you dial 4 1. You will have one call parked at your station.

The Line or Intercom LED will flash green at the in-use rate.

The Line or Intercom LED will turn off.

**To Retrieve the Parked Call on Your Telephone:**

1. Press the **Intercom** button, then dial **4 2**.

You will be reconnected to the call.

*NOTE: When a CO line is placed on hold or parked, it may be retrieved from any station:*

- By pressing a CO line button.
- Pressing the Intercom button and dialing 5 + the hold intercom number.
- Pressing the Intercom button and dialing 5 7 + the hold intercom number.

**EXCLUSIVE HOLD**

Exclusive Hold allows you to place a call on hold so that you (or somebody using a Call Pickup code at another station) can retrieve it.

**To Place a Call on Exclusive Hold:**

1. While on an outside call, press the **Hold** button twice.

After you press the button the second time, the Line LED will flash green at the exclusive hold rate.

**STRATA DK DIGITAL TELEPHONE**

**FEATURE OPERATION**

**To Retrieve the Call:**

1. Press the **Line** button that is on Exclusive Hold.

Another station user can pick up the call by dialing 5 plus your station number, or by dialing 5 7 plus the CO line number (0 1 ~ 0 4 for DK8, 0 1 ~ 0 8 for DK16) that the call is held on.

**CALL PICKUP**

You can pick up a call that is ringing another station, a call placed on hold at another station, and other types of calls.

**To Pick Up a Ringing CO Line in a Tenant System (Tenants 1 and 2):**

1. Press the **Directed Pickup1** or **Directed Pickup2** button.  
... or ...  
Press the **Intercom** button and dial **5 9**.

After you press the button, you will be connected to an incoming CO line call.

You will be connected to an incoming ringing CO line call after you dial 5 9.

**NOTES:**

1. In non-tenant systems, *Directed Pickup1* will pick up any ringing CO line.
2. This feature does not pick up transferred CO lines that are ringing; see "Directed Call Pickup" that follows for instructions on how to pick up transferred CO lines.

**DIRECTED CALL PICKUP**

Directed Call Pickup provides you with several ways to pick up calls ringing in, or calls held at other stations. You can also pick up a ringing door phone, an intercom page, and an external page with Directed Call Pickup.

**To Use Directed Pickup:**

1. Press the **Directed Pickup** button

If you do not have a Directed Call Pickup button, press the Intercom button, then dial 5, instead.

**STRATA DK DIGITAL TELEPHONE**

**FEATURE OPERATION**

2. Station—Dial a Station number to pick up a call that is ringing in at or held at the station.  
... or ...  
Intercom Page—Dial **3 0**.  
... or ...  
External Page—Dial **3 5**.  
... or ...  
CO line on hold (selective)—Dial the CO line access code (7 0 1 ~ 7 0 4 for DK8, 7 0 1 ~ 7 0 8 for DK16).  
... or ...  
Any ringing CO line—Dial **9**.  
... or ...  
Ringing door phone—Dial **3 0**.

You will be connected to the call ringing in or the held call.

You will be connected to the station from which the page is coming.

You will be connected to the station from which the page is coming.

You will be connected to the CO line that is on hold.

You will be connected to the CO line that is ringing in.

You will be connected to the door phone that is ringing.

**DO NOT DISTURB**

If your station is in the Do Not Disturb mode, intercom calls will not ring your station, calls can't be transferred to it, and Off-hook Call Answering calls to it will be denied. Incoming CO line calls, though, will transfer to your station. You can continue to make calls as normal while in the Do Not Disturb mode.

**To Activate Do Not Disturb:**

1. Press the **Do Not Disturb** button.

After you press the button, the Do Not Disturb LED will light, and the Do Not Disturb mode will be activated.

**To Deactivate Do Not Disturb:**

1. Press the **Do Not Disturb** button.

The Do Not Disturb LED will turn off, and the Do Not Disturb mode will be deactivated.

**NOTES:**

1. Calls will forward from your station if it is set for Call Forward Busy or Call Forward-Busy/No Answer while in the Do Not Disturb mode.
2. Some stations may be programmed to override Do Not Disturb.

**STRATA DK DIGITAL TELEPHONE**

**FEATURE OPERATION**

**AUTOMATIC CALLBACK**

After reaching a busy or Do Not Disturb (DND) station, you may set Automatic Callback to have the system call you back when the called station becomes available.

**To Set Automatic Callback (to busy or DND station):**

- |  |  |
|--|--|
| 1. After reaching a busy station, press the <b>Auto Callback</b> button or dial <b>4</b> . | After you press the button or dial 4, the busy tone will stop. You will hear dial tone for two seconds, then the busy tone should resume.  |
| 2. Place the handset on-hook.  | You may make other calls while waiting for the station to become available.  |
| 3. Your telephone will ring at a fast rate when the called station becomes idle.           | The Intercom LED will flash green at the incoming call rate.   |
| 4. Answer the call immediately.  | Answer within three rings to prevent the callback from being cancelled.<br><br>You will hear a single tone, and the Intercom LED will flash green at the in-use rate. The called station will have voice announce activated. (With Tone Signaling, you would hear ringback tone and the called station would ring.)<br><br>If you hear a busy tone after answering a callback, the called party has already received or originated another call. Your request is not cancelled. You will be called again when the station becomes available. |
| 5. Make a voice announce and converse.   |  |

**To Cancel Automatic Callback (to busy or DND station):**

- |   |  |
|---|--|
| 1. Press the <b>Auto Callback</b> button.<br>... or ...<br>Press the <b>Intercom</b> button, then dial <b>4 3</b> . | Automatic Callback will be cancelled.<br><br>Automatic Callback will be cancelled. |
|---|--|

**STRATA DK DIGITAL TELEPHONE**

**FEATURE OPERATION**

**CO LINE QUEUING WITH AUTOMATIC CALLBACK**

Automatic Callback enables you to be placed in a waiting queue for an available CO line after attempting access to a line group in which all lines are busy. The system will call you back when a line becomes available.

**To Set CO Line Queuing:**

- |  |  |
|--|--|
| 1. If all outgoing lines are busy, you will hear busy tone after dialing a line access code. |  |
| 2. Press the <b>Auto Callback</b> button or dial <b>4</b> .                                  | After you press the button or dial 4, the busy tone will stop, you will hear dial tone for two seconds, then busy tone will resume.  |
| 3. Place the handset on-hook.  | You may make other calls while waiting for a line to become available.   |
| 4. Your telephone will ring at a fast rate when a CO line becomes idle.                      | The Line LED will flash green at the incoming call rate.   |
| 5. Lift the handset immediately.   | Answer within three rings to prevent the callback from being cancelled.<br><br>You will hear CO dial tone. (If you hear a busy tone, the line has either been seized or has received an incoming call. Your request is cancelled. You will be called again the next time a line becomes available.)<br><br>The Line LED will flash green at the in-use rate. |
| 6. Dial a telephone number.  | If the original call was made using Least Cost Routing (LCR), the telephone number would have been automatically dialed in Step 4.   |

**To Cancel Automatic Callback (CO Line Queuing):**

- |   |  |
|---|--|
| 1. Press the <b>Auto Callback</b> button.<br>... or ...<br>Press the <b>Intercom</b> button, then dial <b>4 3</b> . | Automatic Callback will be cancelled.<br><br>Automatic Callback will be cancelled. |
|---|--|

### ACCOUNT CODE CALLS

Entered before, during, or after a call, Account Codes can be used for a variety of reasons including billing, tracking, and line restriction applications. Account Codes are recorded by the system and can, along with the details of the calls they are associated with, be printed out on a Station Message Detail Recording (SMDR) report.

#### FORCED ACCOUNT CODES

Some applications may require that you enter an Account Code, called a Forced Account Code, before dialing a telephone number.

#### To Record a Forced Account Code:

1. Access a CO line.

You can access a CO line by pressing a Line or Pooled Line Grp button, or by dialing an access code (7 0 1 ~ 7 0 4 for DK8, 7 0 1 ~ 7 0 8 for DK16 for a line number; 8 1 ~ 8 4 for DK8, 8 1 ~ 8 8 for DK16 for a line group; and 9 for the general group or Least Cost Routing).

You will hear dial tone after accessing a line. (If you dialed with Least Cost Routing you will not hear dial tone.)

2. Enter the Forced Account Code.

Dial tone stops after you dial the first digit. You will hear dial tone after you press the last digit of a valid account code, or busy tone if you dial an invalid code. (If you dialed with Least Cost Routing, you will not hear dial tone.)

3. Dial a telephone number.

Any digits dialed after the code is entered in Step 2 will be treated as part of a telephone number.

#### EMERGENCY OVERRIDE OF FORCED ACCOUNT CODES

You can bypass Forced Account Code requirements with three emergency numbers, including 911. See your system administrator for these numbers:

1) 911      2) \_\_\_\_\_      3) \_\_\_\_\_

#### VOLUNTARY ACCOUNT CODES

Voluntary Account Codes are optional and can be entered after seizing a CO line or during a call that you originated or received.

#### To Record a Voluntary Account Code:

1. After seizing a CO line or during the call, press the **Account Code** button.

Your conversation will not be interrupted.

... or ...

- Press the **Speed Dial** (or **\***) button and dial **5 0**.

Your conversation will not be interrupted.

2. Enter the Account Code.

When your station is set for Verified Account Codes, you will hear a confirmation tone (one-half second duration) if the code is valid. If the code is invalid, you will hear two short tones. Repeat Steps 1 and 2 to dial another account code; the last code entered will be recorded.

Any digits dialed after the code has been entered will be treated as part of the outside telephone number.

#### NOTES:

1. Voluntary Account Codes can be set in system programming to change the Toll Restriction classification of your station. See your system administrator for more information.
2. If your station is programmed not to verify Account Codes, you will not hear a confirmation tone.
3. The outside party will not be able to hear tones when the Account Code digits are being entered or any confirmation tones.
4. Voluntary Account Codes must be entered before the station is disconnected.

#### VERIFIED ACCOUNT CODE CHANGES

If the system is set for Verified Account Codes, station users may dial specific codes when entering Forced or Voluntary Account Codes. Verified Account Codes are established in system programming by designated stations.

#### To Add, Delete, or Change Verified Account Codes From a Designated Station:

1. Press the **Intercom** button, then dial the Verified Account Code Change Access Code.

You will hear confirmation tone.

For security reasons the Account Code Change Access Code is not provided in this guide. Contact your system administrator for the access code.

**STRATA DK DIGITAL TELEPHONE**

**FEATURE OPERATION**

2. Dial the Verified Account Code Number (0 0 0 ~ 0 9 9 for DK8, 0 0 0 ~ 2 9 9 for DK16).
3. Enter the Verified Account Code.
4. Press the **Redial** button.
5. Repeat Steps 1 ~ 4 to enter more Verified Account Codes.

Verified Account Codes can be one to 15 digits.

The newly entered code will overwrite any Verified Account Code that may have previously been stored with the Verified Account Code Number (0 0 0 ~ 0 9 9 for DK8, 0 0 0 ~ 2 9 9 for DK16).

You will hear confirmation tone, and the code will be stored in memory.

To erase an Account Code from memory, repeat the procedure, skipping Step 3.

**PAGING**

Station users can make page announcements to telephones and external speakers.

**To Page:**

1. Lift the handset.
2. Press the **Intercom** button and dial one of the following access codes:  
**3 0** = All Call  
**3 1** = Station Group A  
**3 2** = Station Group B  
**3 3** = Station Group C  
**3 4** = Station Group D  
**3 9** = All Call (External Page Zones optional)  
**3 5 - 3 8** = External Page Zones (A - D)
3. Make your announcement in a normal voice level and repeat it.

These codes will allow a page to the speakers of telephones in Station Page groups A, B, C, D or the All Call Page group.

Dial 35 for Zone A, 36 for Zone B, 37 for Zone C, and 38 for Zone D.

**STRATA DK DIGITAL TELEPHONE**

**FEATURE OPERATION**

4. Hang up when you complete your announcement.

*NOTE: Each of the page access codes (including the Intercom code) can be stored on a Speed Dial button. See "User Programming - Speed Dial Buttons" later in this chapter.*

**ALL CALL PAGE BUTTON**

You can make an All Call Page to digital and electronic telephones assigned to the "All Call Page group" with the touch of a button. The button assigned in system programming. Stations are assigned to the "All Call Page Group" in system programming.

**To Make an All Call Page:**

1. Lift the handset.
2. Press the **All Call Page** button.
3. Make your announcement in a normal voice level and repeat it.
4. Hang up when you finish your announcement.

The All Call Page button does not access external page speakers.

If you are talking on a CO line, always place the CO line on hold by the Hold button before pressing the All Call Page button.

**DOOR PHONE**

Door phones can be used to call digital and electronic telephones selected in system programming. You can call a door phone and hear the area surrounding the door phone.

**To Answer a Door Phone Call:**

1. You will hear a distinctive ringing tone.
2. Lift the handset.

Your phone will ring five times or only once, depending on system programming.

After you lift the handset, if the door phone is still ringing, the in-use LED will flash green at the in-use rate, and you will be connected to the door phone.

**STRATA DK DIGITAL TELEPHONE**

**FEATURE OPERATION**

3. Dial the door phone intercom number if not connected yet.
4. Hang up when the call is completed.

*NOTE: To pick up door phone calls that are ringing at a station other than yours, press the Intercom button and dial 5 3 0.*

**To Call/Monitor a Door Phone:**

1. Lift the handset.
2. Press the **Intercom** button.
3. Dial the intercom number for the desired door location.
4. Hang up when the call is completed or when you are finished monitoring.

You will hear intercom dial tone, and the Intercom LED will flash green at the in-use rate.

551	Location	_____
552	Location	_____
553	Location	_____
554	Location	_____
555	Location	_____
556	Location	_____

*NOTE: Door phone numbers can be stored on Speed Dial buttons. See "User Programmable Feature Buttons" later in this chapter.*

**To Make a Call from a Door Phone:**

1. Press the button and then release it.
2. When answered, speak at a normal voice level in the direction of the door phone.

You will hear a distinctive ringing tone—five times or once, depending on system programming.

**STRATA DK DIGITAL TELEPHONE**

**FEATURE OPERATION**

**HANDSFREE MONITORING**

Calls placed on hold by an outside party may be monitored handsfree. This feature frees you from having to hold the handset to your ear until the outside party returns to the call, enabling you to take care of other tasks in the meantime.

**To Use Handsfree Monitoring:**

1. While on a call, press and hold down the **Spkr** button.
2. Place the handset on-hook.
3. Release the **Spkr** button.
4. Lift the handset when the distant party returns.

The Spkr LED will light red.

The Spkr LED will remain on.

The Spkr LED will remain on, and sounds from the distant party heard over your telephone speaker.

**ALARM RESET**

Your STRATA DK system may be connected to a facility alarm system. Telephones will produce a startling tone whenever this alarm is activated. Stations with an Alarm Reset button can reset the alarm by pressing the button.

**BACKGROUND MUSIC (BGM) OVER TELEPHONE SPEAKERS**

You may listen to optional Background Music over your station speaker.

**To Listen to BGM on Your Telephone Speaker:**

1. Press the **Tel Set Music** button.  
... or ...  
Press the **Intercom** button, dial **4 8 1**, then press the **Spkr** button.

You will hear BGM over your telephone speaker.

You will hear BGM over your telephone speaker.

**STRATA DK DIGITAL TELEPHONE**

**FEATURE OPERATION**

**To Answer a Message Waiting Indication on Your Telephone:**

1. The **Msg** LED will flash red.
2. Lift the handset, press the **Intercom** button, then the **Msg** button.
3. After receiving the message, place the handset on hook.

Your phone will ring the station or voice mail device that set the indication. Wait for an answer to receive the message.

If there is no answer, hang up and try at a later time. (The LED will continue to flash red.)

If the **Msg** LED continues to flash, you have more messages—repeat Steps 1 – 3 to retrieve them.

Voice mail devices may cancel the indication after a short delay.

**To Cancel the Indication Set on your Telephone:**

1. Answer the Indication, as detailed in the preceding procedure.  
... or ...  
Press the **Msg** button.

The called party must answer—by either going off-hook or by pressing the Spkr button—for the indication to be cancelled automatically.

Do not press the Intercom button.

**To Set a Message Light on another Telephone:**

1. Press the **Intercom** button and dial a station.
2. While listening to the ringback or busy tone, press the **Msg** button or dial **7**.
3. Press the **Spkr** button.

You will hear ringback tone or busy tone.

The **Msg** LED will flash red at the called telephone. The **Msg** LED will light steady red at your telephone.

The **Msg** LED will continue to flash at the called telephone, until the called party retrieves the message by pressing their Intercom and **Msg** button. The **Msg** LED will turn off at your station after you press the **Spkr** button.

**STRATA DK DIGITAL TELEPHONE**

**FEATURE OPERATION**

**To Cancel the Indication that You Set at another Telephone:**

1. Dial the station number on which you left the indication.
2. Press the **Msg** button twice.

**NIGHT TRANSFER**

Your system can operate with two or three ringing patterns. Three-pattern systems feature the DAY, DAY 2, and NIGHT modes. Two-pattern ringing pattern systems consist of the DAY and NIGHT modes. The ringing patterns are chosen by pressing the optional Night Transfer button, assigned in system programming.

The Night Transfer LED indicates the active pattern, as follows:

	Three-pattern	Two pattern
DAY	OFF	OFF
DAY 2	FLASH	N/A
NIGHT	ON	ON

**OVERRIDE CALLS**

Busy Override allows you to send a tone to a busy station to indicate that a call is waiting, and Do Not Disturb Override lets you send a tone to an idle station in the Do Not Disturb mode to indicate that a call is pending. You can enter an established conversation with Executive Override.

**To Initiate a Busy Override Signal:**

1. After reaching a busy station, dial **2**.

After dialing **2**, a tone will be heard at the busy station, indicating that a call is waiting.



**STRATA DK DIGITAL TELEPHONE**

**FEATURE OPERATION**

*For Off-hook Call Announce activation:*

- If the busy station is equipped with Automatic Off-hook Call Announce, you will not receive a busy tone and you may converse with the called party after dialing the station number.
- If the called station is equipped for manual Off-hook Call Announce, dialing 2 (with Voice First Signaling) or 2 1 (with Tone Signaling) will make an Off-hook Call Announce call to that station.

**To Initiate a Do Not Disturb Override Signal:**

1. After reaching a Do Not Disturb station, dial **2**.

After dialing 2, a tone signal will be heard at the Do Not Disturb station, indicating that a call is coming in.

Your station must be enabled in system programming to send a Do Not Disturb Override signal.

*NOTE: Privacy Override and Off-hook-Call Announce are described in separate sections of this guide and are listed in the index.*

**To Initiate Executive Override:**

1. After reaching a busy station, dial **3**.

After dialing 3, you will enter the conversation. An optional tone signal may be heard by the called parties prior to your entrance.

Your station must be enabled in system programming for Executive Override.

**SPEAKERPHONE**

Digital telephones with speakerphones can make and receive calls without lifting the handset. Any digital telephone model with an "S" in the model name is equipped with a speakerphone.

**OUTSIDE CALLS**

You can make and receive outside calls without lifting your handset.

**STRATA DK DIGITAL TELEPHONE**

**FEATURE OPERATION**

**To Make an Outside Call (On-hook Dialing)**

1. Leave the handset on-hook.
2. Press any available **Line** or **Pooled Line Grp** button.  
... or ...  
Press the **Intercom** button, then dial a CO line or line group access code.

After you press the button, the Line or Pooled Line Group LED will flash green at the in-use rate, and you should hear dial tone.

The Intercom LED will flash green at the in-use rate, and you will hear dial tone.

CO line access codes are 7 0 1 ~ 7 0 4 (for DK8) and 7 0 1 ~ 7 0 4 (for DK16); line group codes are 8 1 ~ 8 4 (for DK8) and 8 1 ~ 8 4 (for DK16) and the general group and Least Cost Routing code is 9

3. Dial a telephone number.
4. Speak at a normal voice level toward the telephone.
5. Press the **Spkr** button to disconnect the call.

You will hear ringback tone (or busy tone, if busy).

**To Receive an Incoming Call:**

1. You will hear a ringing tone.
2. Leave the handset on-hook.
3. Press the **Line** button or the **Pooled Line Grp** button next to the flashing LED.
4. Speak at a normal voice level towards the telephone.
5. Press the **Spkr** button to disconnect the call.

The Line LED will flash red at the incoming call rate.

After you press the button, the Line or Pooled Line Group LED will flash green at the in-use rate, and you will be connected to the call.

**INTERCOM CALLS**

You can make and receive intercom calls without lifting your handset.

**STRATA DK DIGITAL TELEPHONE**

**FEATURE OPERATION**

**To Cancel BGM on Your Telephone Speaker:**

- 1. Press the **Tel Set Music** button. The BGM will quit playing over your telephone speaker.
- ... or ...
- Press the **Intercom** button, dial **4 8 0**, then press the **Spkr** button. The BGM will quit playing over your telephone speaker.

**To Control BGM Volume:**

- 1. Press the **Intercom** button. You will hear intercom dial tone after pressing the button.
- 2. Press the **Vol** button and adjust while listening to the dial tone. The relative volume level of the BGM will be the same as the dial tone.
- 3. Press the **Spkr** button after setting the volume level.

*NOTE: The Off-hook Call Announce volume level corresponds with the intercom and BGM levels.*

**BACKGROUND MUSIC (BGM) OVER EXTERNAL SPEAKERS**

Station 10 (typically the system administrator's station) can turn BGM over external speakers on and off. Other stations can only control BGM being played over their telephone speakers.

**To Turn On BGM over External Speakers from Station 10:**

- 1. Press the **Intercom** button and dial **4 9 1**. You will hear busy tone when you dial 4 9 1.
- 2. Press the **Spkr** button. The busy tone will stop and BGM will play over the external speakers after your press the Spkr button.

**STRATA DK DIGITAL TELEPHONE**

**FEATURE OPERATION**

**To Turn Off BGM over External Speakers from Station 10:**

- 1. Press the **Intercom** button and dial **4 9 0**. You will hear busy tone when you dial 4 9 0.
- 2. Press the **Spkr** button. The busy tone will stop and BGM will stop playing over the external speakers after you press the Spkr button.

**DIRECT INWARD SYSTEM ACCESS (DISA)**

Outside callers with telephones that send Dual-tone Multi-Frequency (DTMF) tones can call in on CO lines programmed for DISA and use stations or outgoing CO lines without going through an attendant or operator.

**To Make a Direct Inward Station Call with DISA:**

- 1. From outside the system, call the DISA CO line telephone number: \_\_\_\_\_ See the system administrator for this number.
- 2. Listen for the ringback tone signal, then listen for intercom dial tone. Try again if you hear busy tone.
- 3. Dial a station number. You will be connected when the station answers.

Dial tone will be present for 10 seconds to allow direct dialing of a station intercom number or CO line access code. If a number is dialed, the system automatically causes the DISA CO line to treat telephones as a normal incoming call. Then, if the call is not answered within 15 seconds after the ringing starts, it will disconnect.

If you receive busy tone or wish to dial another number while making a station, press the **\*** button to receive dial tone, allowing another number to be dialed.

If the call is not answered after six rings or 24 seconds, whichever comes first, busy tone will be sent. Dial **\*** to access dial tone and dial the station or another number. To call another station after completing a DISA station call, the internal party must transfer you. Station and System Page cannot be accessed on DISA calls.

**STRATA DK DIGITAL TELEPHONE**

**FEATURE OPERATION**

**To Make an Outgoing Call with DISA:**

1. From outside the system, call the DISA CO line telephone number: \_\_\_\_\_.
2. Listen for the ringback tone signal, then listen for intercom dial tone.
3. Dial a CO line or line group access code.
4. If a DISA security code is required, dial the code, then listen for CO dial tone.  
... or ...  
If a DISA security code is not required, you should hear CO dial tone.
5. Dial a telephone number.

See the system administrator for this number.

Try again if you hear busy tone.

Dial tone will be present for 10 seconds to allow direct dialing of a station intercom number or CO line access code. If a number is not dialed, the system automatically causes the DISA CO line to ring at telephones as a normal incoming call. Then, if the call is not answered within 15 seconds after the ringing starts, it will disconnect.

CO line number access codes are 7 0 1 ~ 7 0 4 (for DK8) and 7 0 1 ~ 7 0 8 (for DK16), and line group access codes are 8 1 ~ 8 4 (for DK8) and 8 1 ~ 8 8 (for DK16). The Least Cost Routing code (9) is not allowed.

If required, see the system administrator for this number. If the correct code is not entered, the call will be disconnected.

A timer tone that is audible to both parties will sound approximately four minutes after the call was made. Dial 0 to reset the timer each time the tone sounds for an additional four minutes. If you fail to dial 0, the call will disconnect approximately one minute after the tone.

**DISA SECURITY CODE ENTRY/CHANGE/CANCEL**

Only stations selected in system programming can enter, change, and cancel the DISA security code.

**To Enter, Change, or Cancel the Code from a Selected Station:**

1. Press the **Intercom** button, then dial the three-digit access code.

After you dial the access code, you will hear confirmation tone.

For security purposes, the access code is not published here, but it is available from your system administrator.

**STRATA DK DIGITAL TELEPHONE**

**FEATURE OPERATION**

2. Enter the new DISA security code (1 ~ 15 digits).
3. Press the **Redial** button.

If a DISA security code is not entered, the security code will be canceled and outgoing line access via DISA will not require a security code.

You should hear confirmation tone.

**DIRECT STATION SELECTION BUTTONS (HOTLINE)**

This optional feature allows you to connect directly to another station by pressing a Direct Station Selection (DSS) button. The LED of the button shows the status (idle/busy) of the station associated with it. If connected to a CO line, pressing this button will put the party on hold, making a call as you would normally, by voice announcing or comparing to a hanging up.

**DOOR LOCK**

Your telephone may have an Unlock Door button(s), which will unlock the door lock when pressed.

Door Lock Button	Location
Unlock Door 0	_____
Unlock Door 1	_____
Unlock Door 2	_____

The door lock will unlock for three or six seconds when you press the button, depending on system programming. The Unlock Door LED will turn on for however long the door is unlocked.

**MESSAGE WAITING**

If you call a station and its user does not answer, you can leave a message waiting indication by pressing the Msg button. The Message Waiting LED at the called station will flash after you press the button. The user can call you back by pushing the Msg button with the flashing LED. Other call devices, as well as people, can leave message waiting indications.

Up to four message waiting indications may be left at a station at one time. One of the indications is reserved for the Message Center, per system programming.

**STRATA DK DIGITAL TELEPHONE**

**FEATURE OPERATION**

**To Make an Intercom Call (On-hook Dialing) with Voice First Signaling:**

1. Leave the handset on-hook.
2. Press the **Intercom** button.
3. Dial the desired station number.
4. Speak toward the telephone at a normal voice level.
5. Press the **Spkr** button to disconnect the call.

After pressing the button, the Intercom LED will flash green at the in-use rate, and you will hear intercom dial tone.

You will hear a single ring tone if the called station is idle. (If the call was made with Tone Signaling, you would hear ringback or busy tone.) Dialing 1 after the station number will change the signaling method; see "Tone/Voice First Signaling" for more information.

**If you dial a busy station:**

- Dial 2 or 2 1 to activate Busy Override or, if the called station is properly equipped, Off-hook Call Announce.
- Dial 3 to Executive Override (system programmable option) the called station.
- Dial 4 to set Automatic Callback.

If the called station is busy or unanswered, you can dial 7 to set a Message Waiting Indication.

*NOTE: See "Handsfree Answerback" to receive on-hook intercom calls.*

**MICROPHONE CONTROL**

If you have a speakerphone, press the Mic button to switch the microphone on and off while your telephone is in use (see Microphone Cut-off). The Mic LED indicates the status of the microphone:

LED	MICROPHONE
ON	ON
OFF	OFF

**STRATA DK DIGITAL TELEPHONE**

**FEATURE OPERATION**

All digital telephone users can answer intercom calls (handset on-hook), but only users with a speakerphone can talk handsfree while originating calls while on-hook.

The microphone and accompanying LED are always on when making intercom calls to allow Handsfree Answerback, and (only on CO lines) when placing an on-hook CO line or intercom call.

- Each station's microphone may be set in system programming to be either on or off at the start of handsfree dialing.
- Each station's Mic button may be set in system programming to switch on/off with one touch or to switch off only while programming.

**NOTES:**

1. To change from speakerphone to handset, lift handset.
2. To change from handset to speakerphone:
  - Press and hold down the Spkr button.
  - Return handset on-hook.
  - Release the Spkr button.
3. The Mic and Microphn Cut-off buttons function on all lines. Announce calls for privacy.

**TWO (TANDEM) CO LINE CONNECTION**

You can connect two CO lines and then drop out of the conversation. Your telephone must have Line or Pooled Line Grp buttons for both lines and must be allowed to operate this feature in system programming.

**To Establish a Tandem CO Line Connection (Line to Line):**

1. While on a CO line call, press the **Cnf/Trn** button.
2. Press another **Line** or **Pooled Line Grp** button and dial a telephone number.
3. Press the **Cnf/Trn** button after the party answers.

After you press the button, you will hear intercom dial tone. The Line or Pooled Line Grp LED will flash green at the conference rate. The Intercom LED will flash green at the in-use rate.

The new Line or Pooled Line Grp LED will flash green at the in-use rate.

The Line or Pooled Line Grp LEDs will flash green at the in-use rate. All parties will be conferenced.

If you receive a busy tone or no answer, return to the original call by pressing the original Line or Pooled Line Grp button.

**STRATA DK DIGITAL TELEPHONE**

**FEATURE OPERATION**

4. Press the **Cnf/Trn** button. You will hear intercom dial tone.  
  
The Line or Pooled Line Grp LEDs will both flash green at the exclusive hold rate, and the Intercom LED will flash green at the in-use rate.
5. Hang up. Both Line or Pooled Line Grp LEDs will continue to flash at the exclusive hold rate, and the lines will be connected. The Intercom LED will turn off.  
  
If the public telephone company provides auto disconnect, the connection may release automatically when the parties hang up. If not, the lines must be supervised to be disconnected (See "Supervision" following this procedure).

**SUPERVISION**

You may have to monitor the Tandem call and disconnect the CO lines when the call is completed.

**To Supervise a Tandem Call and Release It:**

1. Press either **Line** or **Pooled Line Grp** button. After you press the button, you will be connected to both CO lines, and both Line or Pooled Line Grp LEDs will flash green at the in-use rate.
2. If the parties have hung up, go back on-hook. Both Line or Pooled Line Grp LEDs will turn off, and the connection will be released.  
... or ...  
If the parties are still talking, return to Step 4 in the preceding procedure.

**TIMED REMINDERS**

You can set five separate reminders at your station. Your telephone will sound a distinct beeping at the exact minute and hour you set for any of these reminders, either one time or daily.

**To Enter a Timed Reminder:**

1. Press the **Intercom** button and dial **6 0 5 - 6 0 9**. You have a choice of five different reminders.

**STRATA DK DIGITAL TELEPHONE**

**FEATURE OPERATION**

2. Enter the desired time. Set the time by entering two digits for the hour of the day (hh) and two digits for the minute (mm). To enter a reminder for 8:30 a.m., enter 8 for the hour, then 3 0 for the minute. To enter a reminder for 8:20 p.m., enter 2 0 for the hour (8 p.m. is the 20th hour of the day), then 2 for the minute.  
  
You will hear a confirmation tone, and the time will be stored in memory.  
  
You will hear a beeping tone for 30 seconds (or until cancelled by going off-hook) when the hour and minute occur.
3. Dial **0** for the reminder to be repeated every day, or **1** for a one-time reminder only.
4. Press the **Redial** button.

**To Cancel a Timed Reminder:**

1. Press the **Intercom** button, then dial **6 0 5 - 6 0 9**. Dial 6 0 5 to cancel the reminder set for 6 0 5; or dial 6 0 6 to cancel the reminder set for 6 0 6, etc. You can only cancel one reminder at a time.
2. Press the **Redial** button. The reminder will be cancelled.

**TOLL RESTRICTION OVERRIDE**

You can completely override Toll Restriction at selected stations. You can change the station's Toll Restriction class. The station will return to normal class at the conclusion of the call.

**To Override/Change Toll Restriction:**

1. Lift the handset.
2. Press a Toll Restricted **Line** button. After pressing the button, you will hear dial tone, and the Line LED will flash green at the in-use rate.  
  
You can also press the Intercom button, then dial a line number, a time group access code to seize a CO line.
3. Press the **Cnf/Trn** button and enter **4 7**. You will no longer hear dial tone.

**STRATA DK DIGITAL TELEPHONE**

**FEATURE OPERATION**

4. Enter the Toll Restriction Override Code (four digits).
5. Dial a telephone number.

You will hear dial tone.

For security reasons, the override codes are only available on a selected basis. See your system administrator.

**TOLL RESTRICTION OVERRIDE CODE REVISION**

Stations selected in system programming can add, delete, and change the Toll Restriction Override codes.

**To Add, Delete, or Change Override/ Traveling Class Codes from a Selected Station:**

1. Press the **Intercom** button, then enter the three-digit Toll Restriction Override Change Access Code.
2. Enter the four-digit override code.
3. Press the **Redial** button.

After entering the code, you will hear confirmation tone.

For security reasons, the change access code is not in this guide. It is available from your telephone system administrator.

You will hear confirmation tone, and the code will be stored in memory.

Repeat Steps 1 - 3 to enter more Toll Restriction Override Class codes.

**AUTOMATIC HOLD**

Automatic Hold enables you to process calls more quickly. You can automatically place a call on a CO line button (or Intercom) on hold by just pressing another outside line or Intercom button—there is no need to push the Hold button. You can also switch between the new call and the original call without having to press the Hold button. Automatic Hold is assigned on a station-by-station basis in system programming.

**STRATA DK DIGITAL TELEPHONE**

**FEATURE OPERATION**

**To Use Automatic Hold:**

1. While on a call, press another **Line** button or the **Intercom** button to receive or originate a new call.

After you press the button, the original Line LED will flash at the in-use rate, and the original call will be placed on hold.

The LED of the new call will flash at the in-use rate, and the new call will be accessed.

**To Switch between Calls:**

1. Press the **Line** or **Intercom** button of the held call.

The LED of the line just automatically placed on-hold will flash at the hold rate, and the LED of the line just accessed will flash at the in-use rate.

**USER PROGRAMMABLE FEATURE BUTTONS**

You can program Speed Dial buttons or codes to access features, such as Call Park and Page, as telephone numbers. You can store up to 20 digits, enabling you to access a sequence of features, such as Call Park and Page, with a single press in a Speed Dial button. A list of feature access codes in Table 2-A shows the storage instructions for this feature.

**To Store on a Button:**

1. Do not lift the handset.
2. Press the **Redial** button.
3. Press one of the **SD** buttons.
4. Enter a feature access code or sequence of codes.
5. Press the **Redial** button.

If you lifted the handset in Step 1, the system would answer the call with the number that you most recently dialed.

Refer to the Feature Access Code List in Table 2-A.

You can only enter 20 digits maximum. Dialpad digits 0-9, \*, and # are used, while the Cnl/Trn, Intercom, and Hold feature buttons each have a unique code.

The feature access code or codes should be stored in memory.

*NOTE: If the preceding sequence is not completed within 30 seconds (system programmable time), the operation will time out and your telephone will be placed in the idle condition.*

**STRATA DK DIGITAL TELEPHONE**

**FEATURE OPERATION**

**To Store in a System or Station Speed Dial Location:**

1. Do not lift the handset.
2. Press the **Redial** button, then the **Speed Dial** button.
3. Dial a 2-digit Speed Dial location.
4. Enter a feature access code or sequence of codes.
5. Press the **Redial** button.

If you lifted the handset in Step 1, the system would automatically dial the number that you most recently dialed after you press the Redial button.

If your station does not have the Speed Dial button, dial \* instead.

Station Speed Dial locations are 1 0 ~ 4 9. System Speed Dial locations are 6 0 ~ 9 9 and can only be stored at Station 10.

Refer to the feature access code list in Table 2-A.

You can only enter 20 digits maximum. Dial pad digits count as 1 digit, while the Cnf/Trn, Intercom, and Hold feature buttons each count as two.

The feature access code or codes are stored in memory.

*NOTE: To exit the entry mode to answer or make a call, press the Redial button.*

**STRATA DK DIGITAL TELEPHONE**

**FEATURE OPERATION**

FEATURES	2000-SERIES TELEPHONE FEATURE ACCESS CODES
Account Codes <sup>7</sup> (Frequently used codes) .....	<b>Cnf/Trn + 4 6</b> + Account code digits
Automatic Callback .....	<b>4</b>
Background Music <sup>6</sup> (External Speakers On).....	<b>Intercom + 4 9 1</b>
Background Music <sup>6</sup> (External Speakers Off).....	<b>Intercom + 4 9 0</b>
Call Forward — All Calls (To Station).....	<b>Intercom + 6 0 1</b> + station number
Call Forward — Busy (To Station).....	<b>Intercom + 6 0 2</b> + station number
Call Forward — Busy/No answer (To Station).....	<b>Intercom + 6 0 4</b> + station number
Call Forward — No Answer (To Station).....	<b>Intercom + 6 0 3</b> + station number
Call Forward Cancel.....	<b>Intercom + 6 0 1</b>
Call Park.....	<b>Cnf/Trn + 4 1</b>
Call Park Retrieve (Pickup at your own station).....	<b>Intercom + 4 2</b>
Door Phone Calling.....	<b>Intercom</b> + door phone intercom number
Hookflash Signal <sup>7</sup> .....	<b>Cnf/Trn + 4 5</b>
Off-hook Call Announce .....	<b>2</b>
Overrides (Busy, DND).....	<b>2</b>
Overrides (Executive).....	<b>3</b>
Paging (CO line Auto Hold <sup>4</sup> ) (All Call, Digital and Electronic telephones).....	<b>Hold + Intercom + 3 0</b>
Paging <sup>4</sup> (Station Group A).....	<b>Hold + Intercom + 3 1</b>
Paging <sup>4</sup> (Station Group B).....	<b>Hold + Intercom + 3 2</b>
Paging <sup>4</sup> (Station Group C).....	<b>Hold + Intercom + 3 3</b>
Paging <sup>4</sup> (Station Group D).....	<b>Hold + Intercom + 3 4</b>
Paging <sup>4</sup> (External Page Zone A).....	<b>Hold + Intercom + 3 5</b>
Paging <sup>4</sup> (External Page Zone B).....	<b>Hold + Intercom + 3 6</b>
Paging <sup>4</sup> (External Page Zone C).....	<b>Hold + Intercom + 3 7</b>
Paging <sup>4</sup> (External Page Zone D).....	<b>Hold + Intercom + 3 8</b>
Paging <sup>4</sup> (All Call, External Page Zone).....	<b>Hold + Intercom + 3 9</b>
Pickup <sup>4</sup> (Directed to station, new, or transferred call).....	<b>Hold + Intercom + 5</b> + station number
Pickup <sup>4</sup> Any ringing CO line (new call only).....	<b>Hold + Intercom + 5 9</b>
Pickup Station Page or Ringing Door Phone <sup>4</sup> .....	<b>Hold + Intercom + 5 3 0</b>
Pickup <sup>4</sup> External Page.....	<b>Hold + Intercom + 5 3 5</b>
One-touch Voice Mail Access.....	<b>Intercom</b> + VM intercom number
Outgoing Calls.....	<b>Intercom</b> + CO line access code <sup>5</sup> + telephone number

**NOTES:**

1. The feature access starting sequence and the actual feature access codes are shown in bold letters in the above table.
2. This table uses 2000-series telephone button labels. 1000-series label equivalents are as follows:

**HNT for Intercom**  
**HOLD for Hold**  
**CONF/TRNS for Cnf/Trn**

3. The storage sequence for User Programmable Feature Buttons is as follows:  
**Redial + SD + Feature Access Code(s) + Redial**
4. This feature will place an existing call on hold when the button is pressed. If the button is pressed when not on a call, the call will still be accessed (These buttons are not available on incoming calls to Toll Restricted stations).
5. CO line access codes: 701 - 704 maximum for DKB individual lines, 701 - 708 maximum for 1K16, 81 - 88 for line groups, 709 - 712 for general group of LCR.
6. Background music speakers can be turned on or off from Station 200 only.
7. These codes can be used during a CO line call.

**Table 2-A**  
**Feature Access Code List**

## Chapter 3

STRATA DK DIGITAL TELEPHONE

TOSHIBA VP INTEGRATION

### USING THE TOSHIBA VP VOICE MAIL SYSTEM

This chapter explains how to program your telephone for Call Forward and message retrieval when using the Toshiba Voice Processing (VP) System (i.e., the VP 100, the VP 200, or the VP 300) with your STRATA DK system.

Refer to the *Toshiba Voice Processing User Guide* for more user information about the Toshiba VP system. Other related documents include: the *Toshiba Voice Processing Quick Reference Guide*, the *Toshiba Voice Processing Product and Feature Description Manual*, and the *Toshiba Voice Processing Configuration Manual*.

---

### CALL FORWARD

You can program your telephone to forward to the Toshiba VP system to answer your calls when you are busy or not available.

#### VOICE MAIL IDENTIFICATION CODE

To direct forwarded calls to your mailbox—your personal storage space for voice messages—and to ensure that callers receive your personal greeting, you must store a Voice Mail (VM) Identification (I.D.) code from your telephone.

#### To Store the Voice Mail I.D. Code:

1. Press the **Intercom** button. After you press the button, you will hear intercom dial tone.
2. Dial **6 5 6**. You will hear confirmation tone. "656" is the VP System Identification code when Call Forward is set. This code does not forward calls to the VP system.
3. Dial **9 1**.
4. Enter your mailbox number.
5. Press the **Redial** button, then the **Spkr** button. You will hear confirmation tone. The VM I.D. code will be automatically sent to the VP system whenever calls are forwarded to it.



**STRATA DK DIGITAL TELEPHONE**

**TOSHIBA VP INTEGRATION**

*NOTE: Steps 1 - 5 are required for the initial storage of the VM I.D. code to the VP system. Once programmed, these digits remain in memory until changed. Repeat Steps 1 - 5 to change the code.*

**To Cancel the Voice Mail I.D. Code:**

1. Press the **Intercom** button. You will hear intercom dial tone after you press the button.
2. Dial **6 5 6**.
3. Press the **Redial** button. You will hear confirmation tone.
4. Press the **Spkr** button. The I.D. code will be cancelled.

**CALL FORWARD TO TOSHIBA VP VOICE SYSTEMS**

By registering Call Forward to the Toshiba VP System on your telephone, information about the call will automatically be provided to the VP system, so that the caller does not have to re-enter the last few digits of the extension number that they have initially dialed.

**To Forward Calls to the Toshiba VP System:**

1. Press the desired Call Forward button. The LED associated with the button will flash after you press the button.  
... or ...  
Press the **Intercom** button, You will hear confirmation tone after entering the access code, then enter a Call Forward access code.

*NOTE: Following is a list of Call Forward access codes:*

- Call Forward-All Calls: 601
- Call Forward-Busy: 602
- Call Forward-No Answer: 603
- Call Forward-Busy/No Answer: 604

2. Dial the VP System number. See your system administrator for the correct voice mail intercom number. After dialing, you will hear confirmation tone if you dialed an access code.
3. Press the Call Forward button or the **Spkr** button. The Call Forward LED will light steady red if you have the Call Forward button.

**STRATA DK DIGITAL TELEPHONE**

**TOSHIBA VP INTEGRATION**

**To Cancel Call Forward to the Toshiba VP System:**

1. Press the appropriate Call Forward button.  
... or ...  
Press the **Intercom** button, enter **6 0 1**, then press the **Spkr** button.

The Call Forward LED will turn off, and Call Forward will be cancelled.

You will hear confirmation tone, and Call Forward will be cancelled.

**VOICE MAIL MESSAGE RETRIEVAL**

You can program your Msg button to automatically retrieve your voice mail messages when you press it.

**To Program your Msg Button to Retrieve Messages:**

1. Press the **Intercom** button.
2. Dial **6 5 7**.
3. Dial **9 2**.
4. Enter your mailbox number, then **# #**.
5. Enter your security code.
6. Press the **Redial** button.
7. Press the **Spkr** button.

You will hear confirmation tone after you press the button.

You will hear confirmation tone. "657" is the VP System Identification code for message retrieval from voice mail.

Your telephone must have the Speed Dial button for the # button to function properly with the VP system.

Storing your security code will save you from having to enter your security code every time you access your mailbox; however, this will not allow anyone to retrieve your messages from your phone. If a security code is not desired, do not include it.

You will hear confirmation tone.

**To Retrieve Messages with the Msg button:**

1. When the Msg LED flashes, press the **Intercom** button.
2. Press the **Msg** button.

The VP System will be called and you should be able to listen to your messages.

## Chapter 4

STRATA DK DIGITAL TELEPHONE

CENTREX APPLICATION

### GENERAL

Your system may be equipped with the Centrex Application, which enhances its feature capability when installed behind a Centrex or PABX system. Your telephone may have access to one or more of the enhanced Centrex features listed below:

#### FLEXIBLE INTERCOM NUMBERING

A station intercom number can be three or four digits. It is, therefore, possible to match a station's intercom and Centrex line extension number. Dial the entire station number when indicated.

*NOTE: Some access code numbers may have been changed to avoid system numbering plan conflicts.*

#### CENTREX FEATURE BUTTONS

You may access some Centrex features by pressing a preprogrammed flexible button on your telephone, instead of dialing a Centrex access code. The Centrex access code, including the necessary flash and/or pause sequence, is activated when the button is pressed. See your Centrex or PBX operations manual for specific details.

#### RINGING REPEAT

The distinctive ring patterns available in your Centrex system are automatically repeated with your digital telephone, allowing you to answer appropriately for either outside, inside, or callback calls.

#### DELAYED RINGING

CO or Centrex line(s) may be programmed for a 12-second and/or 24-second ring delay at stations to permit alternate answering conditions. Answer the line when your telephone is ringing.

## Appendix A

STRATA DK DIGITAL TELEPHONE

1000-SERIES BUTTON DESIGNATIONS

### 1000-SERIES TELEPHONE BUTTON DESIGNATIONS

The feature operation procedures in this user guide use the button designations for the 2000-series models. This appendix provides the equivalent designations for the 1000-series models.

1000-SERIES TELEPHONE	2000-SERIES TELEPHONE	BUTTON FUNCTION
<b>ABR</b>	<b>Auto Busy Redial</b>	AUTOMATIC BUSY REDIAL
<b>AC</b>	<b>All Call Page</b>	ALL CALL VOICE PAGE
<b>ACB</b>	<b>Auto Callback</b>	AUTOMATIC CALLBACK
<b>ACCNT</b>	<b>Account Code</b>	ACCOUNT CODE
<b>ALRM</b>	<b>Alarm Reset</b>	ALARM RESET
<b>BGM</b>	<b>Tel Set Music</b>	BACKGROUND MUSIC
<b>CFAC</b>	<b>Call Frwd All Calls</b>	CALL FORWARD-ALL CALLS
<b>CFB</b>	<b>Call Frwd Busy</b>	CALL FORWARD-BUSY
<b>CFB/NA</b>	<b>Call Frwd Busy NAns</b>	CALL FORWARD-BUSY/NO ANSWER
<b>CFNA</b>	<b>Call Frwd No Answer</b>	CALL FORWARD-NO ANSWER
<b>CFF</b>	<b>Call Frwd to: _____</b>	CALL FORWARD-FIXED
<b>CO</b>	<b>Line</b>	LINE

**STRATA DK DIGITAL TELEPHONE**

**1000-SERIES BUTTON DESIGNATIONS**

1000-SERIES TELEPHONE	2000-SERIES TELEPHONE	BUTTON FUNCTION
<b>CONF/TRNS</b>	<b>Cnf/Trn</b>	CONFERENCE/TRANSFER (FIXED)
<b>DATA</b>	<b>Data Call</b>	DATA
<b>DND</b>	<b>Do Not Disturb</b>	DO NOT DISTURB
<b>DRLK</b>	<b>Unlock Door</b>	DOOR LOCK
<b>DRLS</b>	<b>Data Release</b>	DATA RELEASE
<b>DSS</b>	<b>DSS</b>	DIRECT STATION SELECTION (S)
<b>FLASH</b>	<b>Flash</b>	FLASH
<b>HOLD</b>	<b>Hold</b>	HOLD (FIXED)
<b>INT</b>	<b>Intercom</b>	INTERCOM
<b>MCO</b>	<b>Microphn Cut-off</b>	MICROPHONE CUTOFF
<b>MESSAGE</b>	<b>Msg</b>	MESSAGE WAITING (FIXED)
<b>MIC</b>	<b>Mic</b>	MICROPHONE (FIXED)
<b>MODEM</b>	<b>Modem</b>	MODEM
<b>MSG</b>	<b>LCD Msg Select</b>	MESSAGE SELECT
<b>NT</b>	<b>Night Transfer</b>	NIGHT TRANSFER

**STRATA DK DIGITAL TELEPHONE**

**1000-SERIES BUTTON DESIGNATIONS**

1000-SERIES TELEPHONE	2000-SERIES TELEPHONE	BUTTON FUNCTION
<b>NT1</b>	<b>Night Transfer1</b>	TENANT NIGHT TRANSFER
<b>NT2</b>	<b>Night Transfer2</b>	
<b>PAU</b>	<b>Spd Dial Pause</b>	PAUSE
<b>PAU/L</b>	<b>Spd Dial Lng Pause</b>	PAUSE (LONG)
<b>PKUP</b>	<b>Directed Pickup</b>	CALL PICKUP
<b>PKUP1</b>	<b>Directed Pickup1</b>	TENANT CALL PICKUP
<b>PKUP2</b>	<b>Directed Pickup2</b>	
<b>PL</b>	<b>Pooled Line Grp</b>	POOLED LINE
<b>PRIVACY</b>	<b>Privacy on Line</b>	PRIVACY
<b>PRV RLS</b>	<b>Privacy Release</b>	PRIVACY RELEASE
<b>REDIAL</b>	<b>Redial</b>	REDIAL (FIXED)
<b>RLS</b>	<b>Release Call</b>	RELEASE
<b>SAVE</b>	<b>Save Last Number</b>	SAVE

**STRATA DK DIGITAL TELEPHONE**

**1000-SERIES BUTTON DESIGNATIONS**

1000-SERIES TELEPHONE	2000-SERIES TELEPHONE	BUTTON FUNCTION
<b>SD</b>	<b>SD</b>	SPEED DIAL
<b>SDS</b>	<b>Speed Dial</b>	SPEED DIAL SELECT
<b>SPEAKER</b>	<b>Spkr</b>	SPEAKER (FIXED)
<b>TONE</b>	<b>Tone Dial Select</b>	TONE
<b>VOLUME</b>	<b>Vol</b>	VOLUME (FIXED)

## Index

**STRATA DK DIGITAL TELEPHONE**

<b>A</b>	Account Code Calls 2-34	Delayed Ring
	Emergency Override of Forced Account Codes 2-34	Flexible Int 4-1
	Forced Account Codes 2-34	Ringin Re Conference C
	Verified Account Codes 2-35	Conference C
	Voluntary Account Codes 2-34	CO Lines 2
	Alarm Reset 2-39	Confereñce 2-23
	Automatic Busy Redial 2-5	
	Automatic Callback 2-32	<b>D</b>
	CO Line Queuing with Automatic Callback 2-33	Direct Inwar (DISA) 2-41
	Automatic Hold 2-52	DISA Secu Entry/Chan
	Automatic Off-hook Selection 2-4	Direct Station (Hotline) 2-43
<b>B</b>	Background Music (BGM) Over External Speakers 2-40	Do Not Disturb
	Background Music (BGM) Over Telephone Speakers 1-9, 2-39	Door Lock 2-4
<b>C</b>	Call Forward 2-23, 3-1	Door Phone 2
	Call Forward-All Calls 2-24	DTMF Tone D 2-12
	Call Forward-Busy 2-25	<b>E</b>
	Call Forward-Busy/No Answer 2-26	Exclusive Hold
	Call Forward-Fixed 2-27	<b>F</b>
	Call Forward-No Answer 2-25	Feature Buttor 1000-series Designator
	Call Hold 2-28	<b>G</b>
	Call Park 2-28	Glossary G-1
	Call Pickup 2-30	Group Listenir
	Directed Call Pickup 2-30	<b>H</b>
	Call Transfer with Camp-on 2-19	Handset/He: Tone Option 1
	Answering a Transferred Call 2-20	
	Centrex Application 4-1	
	Centrex Feature Buttons 4-1	

**P**

- Paging 2-36
  - All Call Page Button 2-37
- Privacy Button 2-14
- Privacy Override 2-13
- Privacy Release 2-14

**R**

- Repeat Last Number Dialed 2-5

**S**

- Saved Number Redial 2-11
- Speakerphone 2-46
  - Intercom Calls 2-47
  - Outside Calls 2-46
- Speed Dial 2-6
  - Calling System or Station
  - Speed Dial Numbers 2-10
  - Chain Dialing Speed Dial Numbers 2-11
  - Speed Dial Number Linking 2-9
  - Speed Dial Pause and Flash Storage 2-8
  - Station Speed Dial Storage 2-7
  - System Speed Dial Storage 2-7

**T**

- Timed Reminders 2-50
- Toll Restriction Override 2-51
- Toll Restriction Override Code Revision 2-52
- Tone/Pulse Dialing 2-12
- Toshiba VP Integration 3-1
  - Call Forward to Toshiba VP Systems 3-2
  - Message Retrieval 3-3
  - Voice Mail Identification Code 3-1
- Two (Tandem) CO Line Connection 2-49
  - Supervision 2-50

**U**

- User Programmable Feature Buttons 2-53

**V**

- Voice Mail Message Retrieval 3-3
- Volume Controls 1-7
  - Handset Receiver Volume 1-8
  - Incoming Handsfree Answerback Volume (Ring Tone) 1-8
  - Muted Tone Burst Volume 1-9
  - Off-hook Call Announce Volume -*See Speaker Volume*
  - Ring Tone Volume (Incoming Handsfree Answerback) 1-7
  - Speaker Volume 1-9
  - Station Background Music Volume (Tel Sel Music) -*See Speaker Volume*

**TOSHIBA**

**STANDARD  
TELEPHONE  
USER GUIDE**

**B U S I N E S S  
T E L E P H O N E S  
S O L U T I O N S**



**STRATA® DK**

**DIGITAL KEY  
TELEPHONE SYSTEMS  
STRATA DK8 & DK16**

## Table of Contents

**STRATA DK STANDARD TELEPHONE**

**TABLE OF CONTENTS**

SUBJECT	PAGE
<b>INTRODUCTION</b>	
General Description .....	iii
Purpose .....	iii
Organization .....	iii
How to Use This Guide .....	iv
<b>FEATURE OPERATION</b>	
Outside Calls .....	1-1
Intercom Calls .....	1-1
Automatic Callback .....	1-2
Call Forward .....	1-3
Call Hold/Park .....	1-4
Call Transfer with Camp-on .....	1-5
Conference Calls .....	1-6
Door Phone .....	1-8
Flash CO Line .....	1-9
Account Code Calls .....	1-9
Forced Account Codes .....	1-9
Emergency Override of Forced Account Code Dialing .....	1-10
Voluntary Account Codes .....	1-10
Verified Account Codes .....	1-11
Message Waiting Indication .....	1-11
Override Calls .....	1-12
Paging .....	1-12
Repeat Last Number Dialed .....	1-13
Speed Dial .....	1-14
Tone/Voice First Signaling .....	1-15
CO Line Queuing .....	1-15
Call Pickup .....	1-16
Direct Inward System Access .....	1-17
Toll Restriction Override/Traveling Class .....	1-18
<b>INDEX</b> .....	<b>Index-1</b>

### FIGURE LIST

FIGURE	TITLE	PAGE
1-1	Sample Page .....	v

## Introduction

### GENERAL DESCRIPTION

The STRATA DK8 and DK16 systems provide your standard telephone with a variety of useful calling features, including Call Forward, Call Hold, Conference, and more.

---

### PURPOSE

This document is designed as a feature operating guide for the user of a standard telephone, either rotary dial or push-button tone type. An overview of this user guide will acquaint you with the various features that are available to your telephone and will provide you with the necessary instructions to perform each feature.

---

### ORGANIZATION

This user guide is divided into the following sections:

The Introduction provides an explanation of the purpose and organization of this document. Suggestions on how to use this user guide also appear in the Introduction.

Chapter 1, "Feature Operation," provides descriptions and operating procedures for all of the features available with standard telephones.

The Index provides a way to quickly find all of the features addressed in this guide.



**HOW TO USE THIS GUIDE**

Your telephone's specific calling allowances are determined by assignments made in system programming. Your system administrator can inform you as to which features are actually accessible from your specific telephone. Once you are aware of the features that are available to your telephone, review each feature's description and operational procedure contained in this guide.

To assist you in achieving greater performance efficiency, the information in this user guide is divided into distinct areas of content. Instructions for various procedures are referred to as Action Text and appear in the left-hand column of the page. Instructions appear in numerical sequence, enabling you to quickly perform a specific task. More detailed descriptions of these procedures, or explanations of their effects, are located in the right-hand column. Figure I-1 shows you the structure followed for each feature.

**ACTION TEXT**  
 SPECIFIC INSTRUCTIONS ON HOW TO PERFORM A  
 PROCEDURE ARE NUMBERED AND ENTERED IN  
 THE LEFT-HAND COLUMN.

STRATA DK	FEATURE OPERATION
<p><b>NOTES</b></p> <ul style="list-style-type: none"> <li>1 If you do not return to the call within a designated time period, your telephone will ring to recall you.</li> <li>2 Any color station can pick up the hold call by                     <ul style="list-style-type: none"> <li>■ Obtaining intercom dial tone and dialing 5 + the intercom number of the station that placed the call on hold.</li> <li>■ Entering station dial tone and dialing 5 / + the number 01 .06 of the hold CO line with systems using Release 2 and Intercom Station.</li> </ul> </li> </ul>	
<p><b>CALL TRANSFER WITH CAMP-ON</b></p> <p>This feature allows you to transfer an outside call to a station that is either idle or busy.</p>	
<p><b>To Transfer a Call (Voice First Signaling):</b></p> <ol style="list-style-type: none"> <li>1 While on an outside call, flash the hookswitch.</li> <li>2 Dial the station number to which the call will be transferred.</li> <li>3 If the called station is idle, announce the call after the single ring tone and then hang up.                      or                      If the called station is busy, hang up.</li> </ol>	<p>"Flash the hookswitch" by depressing the hookswitch (labeled in the handset cradle for about 1/2 second. (Some telephones may have a special button which flashes the hookswitch when pressed.)</p> <p>You will hear intercom dial tone after flashing the hookswitch.</p> <p>You can flash the hookswitch again to reconnect to the outside line before it is transferred. If the called station rings the handset for several times, intercom dial tone and electrical busy tones will follow you back the hookswitch again, you will enter a conference call.</p> <p>If this call was made with Tone Signaling status of Voice First Signaling, you would hear registers ringing after dialing the station number and would have to wait for the called party to answer.</p> <p>The call will camp on to the busy station.</p> <p><b>NOTE:</b> The call will recall you by ringing your station and camp on will be cancelled if the station does not answer within a predetermined time interval. Call the station and follow the procedure if necessary.</p>
<p>1-6</p>	

NOTES AND  
 WARNING  
 MESSAGES

CHAPTER TITLES

FIRST LEVEL  
 HEADINGS

RESULTS OR  
 DETAILS  
 EXPLANATIONS  
 OR DETAILS OF  
 THE ACTION TEXT

Figure I-1  
 Sample Page

# Chapter 1

STRATA DK STANDARD TELEPHONE

FEATURE OPERATION

## OUTSIDE CALLS

You can make calls to or receive calls from telephones outside of the STRATA DK system.

### To Make an Outside Call:

1. Lift the handset.
2. Dial a CO line number access code.
3. Dial the desired telephone number.

You will hear intercom dial tone.

CO line number access codes are 7 0 1 ~ 7 0 4 (for DK8) and 7 0 1 ~ 7 0 8 (for DK16). With some systems you may have to dial either the general group code (9), Least Cost Routing code (9), or a Line Group code (8 1 ~ 8 4 for DK8; 8 1 ~ 8 8 for DK16), instead of a CO line number access code.

### To Receive an Incoming Call:

1. You will hear ringing.
2. Lift the handset and speak.

The ringing pattern depends on parameters set in system programming. A distinct outside call ring pattern—0.2 seconds on, 0.4 seconds off, 0.2 seconds on, 3.4 seconds off—is optionally available. Some systems may use the intercom ring pattern—one second on, 3 seconds off—for incoming outside calls.

---

## INTERCOM CALLS

You can make calls to and receive calls from other stations in the STRATA DK system.

### To Make an Intercom Call (Voice First Signaling):

1. Lift the handset.
2. Dial the desired station number.

You will hear intercom dial tone.

If the called station is idle:

- You will hear a single tone if you are calling a digital or electronic telephone station. Speak after you hear the tone.
- If the system was set for Tone Signaling, instead of Voice First Signaling, you would hear repetitive tone ringing for all calls. (You

**STRATA DK STANDARD TELEPHONE**

**FEATURE OPERATION**

can change the signaling mode by pressing 1 after dialing the digital or electronic station number. See Tone/Voice First Signaling later in this guide.)

- If you are calling another standard telephone, you will hear repetitive ringing. Wait for the called station user to answer.
- To leave a Message Waiting Indication at the called station, dial 7.

If you receive busy tone:

- To set Automatic Call Back (ACB), dial 4.
- To activate Busy Override if the called digital or electronic telephone station is not equipped for Off-hook Call Announce (OCA), dial 2. (Standard telephones cannot be equipped to receive OCA.)
- To activate OCA at digital or electronic telephones: With Voice First Signaling and if the called station is equipped for OCA, dial 2. With Tone Signaling and the called station is equipped for OCA, dial 21.
- To leave a Message Waiting Indication at the called station, dial 7.
- Hang up and try again later.

**To Receive an Intercom Call:**

1. You will hear ringing.
2. Lift the handset and speak.

The intercom ring pattern is one second ringing, three seconds silence.

You will be connected to the calling party.

**AUTOMATIC CALLBACK**

After reaching a busy station or a telephone in the Do Not Disturb (DND) mode, you may set Automatic Callback to have the system call you back when the called station is no longer busy or in the DND mode. Automatic Callback does not apply to outside calls.

**To Set Automatic Callback (Voice First Signaling):**

1. After reaching a busy station, dial 4.
2. Hang up.
3. Your telephone will ring at a fast rate when the called station becomes idle.

The busy tone will stop. You will hear dial tone for two seconds, then the busy tone will resume.

You may make other calls while waiting for the called station to become available.

**STRATA DK STANDARD TELEPHONE**

**FEATURE OPERATION**

4. Answer the call immediately.
5. Make voice announcement and then converse.

Answer within three rings to prevent the callback from being cancelled.

You will hear a single tone, as if making a regular intercom call (if using Tone Signaling instead of Voice First Signaling, you would hear repetitive ringing.)

If you hear busy tone after answering, it means the called party has already received or originated another call. Your request is not cancelled. You will be called again when the station becomes idle.

*NOTE: You may cancel the request anytime prior to the callback by lifting the handset and dialing 4 3.*

**CALL FORWARD**

You can set your station to call forward to another station or voice mail under a variety of conditions.

- **Call Forward-All Calls**—If your station is idle or busy and has this feature activated, all calls to it will forward immediately to another station that you preselect. Your station will not ring.
- **Call Forward-Busy**—Calls to your telephone while you are busy on another call will forward immediately to another station that you preselect if this feature is set. Calls will ring as normal if your telephone is idle.
- **Call Forward-No Answer**—Calls to your station when set with this feature will forward to another station that you preselect if you fail to answer within 12 seconds or three rings.
- **Call Forward-Busy/No Answer**—Calls to your station when set with this feature will forward immediately to a station that you preselect whenever you are busy on another call. Calls will also forward if you do not answer within 12 seconds or three rings.

**To Set Call Forward:**

1. Lift the handset.

You will hear intercom dial tone.

**STRATA DK STANDARD TELEPHONE**

**FEATURE OPERATION**

2. Dial one of the following Call Forward access codes:  
**6 0 1** = Call Forward-All Calls  
**6 0 2** = Call Forward-Busy  
**6 0 3** = Call Forward-No Answer  
**6 0 4** = Call Forward-Busy/No Answer
3. Enter the station or voice mail intercom number to which calls will forward.
4. Hang up.

You will hear confirmation tone.

You will hear confirmation tone again and then busy tone.

Calls will forward as applicable.

**NOTES:**

1. You may continue using your phone in the usual manner while Call Forward is in effect.
2. If Call Forward is set:
  - CO lines that ring your station **only** will forward—CO lines that ring more than one station will not forward.
  - CO line calls transferred to your station will forward.
  - Intercom calls will forward.
  - Call Forward has priority over the hunt feature set in system programming.

**To Cancel Any Call Forward Mode:**

1. Lift the handset.
2. Dial **6 0 1**.
3. Hang up.

You will hear intercom dial tone.

This code will cancel any of the Call Forward modes.

You will hear confirmation tone again, then busy tone.

**CALL HOLD/PARK**

You can place a call on hold and then make another call.

**STRATA DK STANDARD TELEPHONE**

**FEATURE OPERATION**

**To Place a Call On Hold/Park:**

1. While on a call, flash the hookswitch.
2. Dial **4 1** and hang up.

"Flash the hookswitch" by depressing the hookswitch (plunger) located in the handset cradle for about 1/2 second. (Some telephones may have a special button which flashes the hookswitch when pressed.)

You must hang up for at least two seconds for the call to be placed on hold.

You may now originate or receive other calls.

**To Return to the Held/Parked Call:**

1. Lift the handset.
2. Dial **4 2**.

You will hear intercom dial tone.

You will be reconnected with the held/parked call.

**NOTES:**

1. If you do not return to the call within a designated time period, your telephone will ring to recall you.
2. Any other station can pick up the held call by:
  - Obtaining intercom dial tone and dialing 5 + your intercom number.
  - Obtaining intercom dial tone and dialing 5 7 + the number of the held CO line, 0 1 ~ 0 4 (for DK8) or 0 1 ~ 0 8 (for DK16).

**CALL TRANSFER WITH CAMP-ON**

This feature allows you to transfer an outside call to a station that is either idle or busy.

**To Transfer a Call (Voice First Signaling):**

1. While on an outside call, flash the hookswitch.

"Flash the hookswitch" by depressing the hookswitch (plunger) located in the handset cradle for about 1/2 second. (Some telephones may have a special button which flashes the hookswitch when pressed.)

You will hear intercom dial tone after flashing the hookswitch.

**STRATA DK STANDARD TELEPHONE**

**FEATURE OPERATION**

2. Dial the station number to which the call will be transferred.
3. If the called station is idle, announce the call after the single ring tone and then hang up.  
... or ...  
If the called station is busy, hang up.

You can flash the hookswitch again to reconnect to the outside line before it is transferred. If the called station lifts the handset (or presses their intercom button on digital and electronic telephones) just before you flash the hookswitch again, you will enter a conference call.

If the call was made with Tone Signaling instead of Voice First Signaling, you would hear repetitive ringing after dialing the station number and you could wait for the called party to answer.

The call will camp-on to the busy station. The called station will receive a call waiting tone to know that a call has been transferred.

*NOTE: The call will recall you by ringing your station (and camp-on will be cancelled) if the station does not answer within a predetermined time. Inform the caller of the situation, and repeat the procedure if necessary.*

**CONFERENCE CALLS**

STRATA DK enables you to participate in a variety of Conference calls of up to four parties:

- Up to four stations (including your own) may be conferenced on intercom.
- Up to three stations (including your own) may be conferenced with one CO line.
- Up to two stations (including your own) may be conferenced with two CO lines.

*NOTE: The STRATA DK8 supports two simultaneous conferences. If a four party conference is in progress, the second conference may contain three parties maximum.*

**To Add a Station to an Existing Call:**

1. While on either an outside call or intercom call, flash the hookswitch.

"Flash the hookswitch" by depressing the hookswitch (plunger) located in the handset cradle for about 1/2 second. (Some telephones may have a special button which flashes the hookswitch when pressed.)

You will hear intercom dial tone after flashing the hookswitch and the call will be placed on hold. You will not hear the held party again until Step 4.

**STRATA DK STANDARD TELEPHONE**

**FEATURE OPERATION**

2. Dial the number of the station you want to add to the call.
3. If you hear a single tone, voice announce the call and ask the party to pick up.
4. Flash the hookswitch when the party answers.
5. Repeat Steps 1 - 4 to add another station to the conference.

The new party must pick up the handset or press their intercom button to participate in a Conference call.

All parties will be conferenced.

If the called station was busy, you could flash the hookswitch to return to the existing call, or you could hang up and receive immediate recall ringing to answer the existing call.

**To Conference By Adding a CO Line to a Call:**

1. While on a CO line or intercom call, flash the hookswitch.
2. Dial a CO line number access code.
3. Dial the desired telephone number you wish to add to the call.
4. Flash the hookswitch when the party answers.
5. Repeat Steps 1 - 4 to add another CO line to the conference.

"Flash the hookswitch" by depressing the hookswitch (plunger) located in the handset cradle for about 1/2 second. (Some telephones may have a special button which flashes the hookswitch when pressed.)

You will hear intercom dial tone, and the existing call will be placed on hold. You will not hear the held party again until Step 4.

CO line number access codes are 7 0 1 - 7 0 4 (for DK8) and 7 0 1 - 7 0 8 (for DK16). With some systems, you may have to dial either the general group code (9), Least Cost Routing code (9), or a Line Group code (8 1 - 8 4 for DK8; 8 1 - 8 8 for DK16), instead of a CO line number access code.

If the party is busy or does not answer, hang up to receive an immediate recall to return to the existing call.

All parties will be conferenced.

Two CO lines maximum can be conferenced. Depending on circumstances, the outside parties may experience difficulty hearing each other.

**NOTES:**

1. While a conference is being set up, all outside parties are held separately and cannot converse with each other.
2. If a four-party conference is set, either inside station will maintain the conference if the other hangs up. But one station must remain in the conference to maintain the outside connections.

**DOOR PHONE**

You can call a door phone and monitor the immediate area surrounding the door phone. Only digital and electronic telephone stations can be called by door phone users, but you can pick up these calls when they are incoming by lifting your handset and dialing a pick up access code.

**To Call/Monitor a Door Phone:**

1. Lift the handset.
2. Dial the intercom number for the desired door location.
3. Hang up when the call is completed or when you no longer wish to monitor the door phone.

You will hear intercom dial tone.

551	Location	_____
552	Location	_____
553	Location	_____
554	Location	_____
555	Location	_____
556	Location	_____

**To Pick Up a Door Phone Call That Is Ringing Another Station:**

1. You will hear a distinct ringing tone at a digital or electronic telephone, or on the paging speaker.
2. Lift the handset.
3. Dial **5 3 0**.

The phone will ring a maximum of once or five times, depending on system programming.

You will hear intercom dial tone.

You will be connected to the door phone.

**FLASH CO LINE**

Some CO line features like conferencing, Centrex features, or behind PBX operation require "flashing" the CO (or Centrex) line.

**To Flash a CO Line:**

1. Momentarily press (for about 1/2 second) the hookswitch.
2. Dial **4 5**.

The hookswitch is located in the handset cradle of your telephone. After you press the hookswitch, you will hear intercom dial tone. (Some telephones may have a special button which flashes the hookswitch when pressed.)

You will hear Centrex or PBX dial tone.

**ACCOUNT CODE CALLS**

Account Codes can be used for a variety of reasons, including billing, call tracking, and line restriction applications. The system records the Account Codes and can print them out along with other call details on a Station Message Detail Recording (SMDR) report.

**FORCED ACCOUNT CODES**

Some applications may require that you enter an Account Code, called a Forced Account Code, before dialing a telephone number. Forced Account Codes can be recorded for outgoing calls only.

**To Record a Forced Account Code:**

1. Lift the handset.
2. Dial a CO line number access code.
3. Enter the Forced Account Code.

You will hear intercom dial tone.

CO line number access codes are 7 0 1 ~ 7 0 4 (for DK8) and 7 0 1 ~ 7 0 8 (for DK16). With some systems, you may have to dial either the general group code (9), Least Cost Routing code (9), or a Line Group code (8 1 ~ 8 4 for DK8; 8 1 ~ 8 8 for DK16), instead of a CO line number access code:

If you dialed a CO line access code, you will hear dial tone after you press the last digit of a valid account code or busy tone after you press the last digit of an invalid code.

**STRATA DK STANDARD TELEPHONE**

**FEATURE OPERATION**

4. Dial the telephone number.

If you dialed 9, you may not hear dial tone. Continue dialing the telephone number after you dial the account code.

**EMERGENCY OVERRIDE OF FORCED ACCOUNT CODE DIALING**

Forced Account Code requirements can be bypassed by three emergency numbers, including 911. See your system administrator for these numbers:

- 1) 911      2) \_\_\_\_\_      3) \_\_\_\_\_

**VOLUNTARY ACCOUNT CODES**

Voluntary Account Codes are optional and can be entered anytime after accessing a CO line or during a call.

**To Record a Voluntary Account Code:**

1. After accessing a CO line or while talking on a line, flash the hookswitch.
2. Dial **4 6**.
3. Enter the Voluntary Account Code.

"Flash the hookswitch" by depressing the hookswitch (plunger) located in the handset cradle for about 1/2 second. (Some telephones may have a special button which flashes the hookswitch when pressed.)

You will hear intercom dial tone; the CO line will be on Hold.

You will hear CO dial tone after dialing 46, or if you were talking, the speech path to you is reconnected in one direction only so that the outside caller cannot hear you or the account code entry but you can still hear the outside caller.

If dialing a Verified Account Code, you will hear one confirmation burst tone if you dial a valid number. If you dial an invalid code, you will hear two burst tones. (Repeat Steps 1 - 3 to try again.)

If you enter the code after accessing a CO line, you will hear CO line dial tone after entering the code. If you enter the code while talking, the speech path will be restored in both directions after you enter the code.

**STRATA DK STANDARD TELEPHONE**

**FEATURE OPERATION**

4. Dial a telephone number if you entered the code after accessing the CO line.  
... or ...  
Resume talking or hang up if you entered the code while talking.

CO dial tone will stop after you dial the first digit of the telephone number. Voluntary account codes must be entered before the call is disconnected.

**VERIFIED ACCOUNT CODES**

Some STRATA DK systems require that specific codes (called Verified Account Codes) set in system memory must be entered when inputting Forced or Voluntary Account Codes. If the system does not require Verified Account Codes, any sequence of numbers can be entered when inputting Account Codes, as long as the number of digits matches a length established in system programming.

**MESSAGE WAITING INDICATION**

After reaching a busy or unanswered digital or electronic telephone, you can set a Message Waiting Indication on the called telephone. A flashing LED at the called telephone will indicate that a call is waiting. The station user can press the button associated with the flashing LED to call you back.

**To Set a Message Waiting Indication:**

1. If a called digital or electronic telephone station is busy or unanswered, dial **7**.
2. Hang up.

The Message Waiting Indication will be set at the station.

**To Cancel the Message Waiting Indication:**

1. Lift the handset and dial the station number on which you left the indication.
2. Dial **7 7**.

You will hear busy tone if the called station is busy, or you will hear repetitive ringing or a single tone if the called station is idle.

The Message Waiting Indication on the station will be turned off.

## VERRIDE CALLS

Busy Override allows you to send a tone to a busy station to indicate that a call is waiting, and Do Not Disturb Override lets you send a tone to an idle station in the Do Not Disturb mode to indicate that a call is coming in. Executive Override enables you to enter an established conversation. Executive Override and Do Not Disturb Override are optional features enabled in system programming. Any station can initiate Busy Override.

### To Initiate a Busy Override

#### Signal:

1. After reaching a busy station, dial **2**.

After you dial 2, a tone signal will be heard at the busy station, indicating that a call is waiting.

If the Off-hook Call Announce option is installed on the busy station, then you may talk.

### To Initiate a Do Not Disturb Override Signal:

1. After reaching a Do Not Disturb station, dial **2**.

After you dial 2, a tone signal will be heard at the Do Not Disturb station, indicating that a call is coming in.

Your station must be enabled in system programming to initiate a Do Not Disturb Override signal.

### To Initiate Executive Override:

1. After reaching a busy station, dial **3**.

After you dial 3, you will enter the conversation. An optional tone signal may be heard by the called parties prior to your entrance.

Your station must be enabled in system programming to initiate Executive Override.

## PAGING

You can make page announcements to digital and electronic telephone speakers and external speakers.

### To Page:

1. Lift the handset and access the intercom.
2. Dial one of the following page access codes:  
**3 0** = All Call  
**3 1** = Station Group A  
**3 2** = Station Group B  
**3 3** = Station Group C  
**3 4** = Station Group D  
**3 9** = All Call  
**3 5 ~ 3 8** = External Page Zones (A ~ D)
3. Make your announcement in a normal voice level and then repeat the announcement.
4. Hang up when you have completed your announcement.

You will hear intercom dial tone.

These codes will allow a page to the speakers of telephones in Station Page groups A, B, C, D or the All Call Page group.

Dial 3 5 for Zone A, 3 6 for Zone B, 3 7 for Zone C, and 3 8 for Zone D.

## REPEAT LAST NUMBER DIALED

This feature enables you to automatically redial the last number called with the touch of a button.

### To Redial the Last Number Dialed:

1. Lift the handset.
2. Dial the # button.

You will hear intercom dial tone.

The system will automatically dial the last telephone number you dialed.



**STRATA DK STANDARD TELEPHONE**

**FEATURE OPERATION**

**SPEED DIAL**

Speed Dial enables you to call telephone numbers by dialing a brief access code, instead of having to dial the entire telephone number. There are two types of Speed Dial numbers. Station Speed Dial numbers are assigned by individual station users to their own station and can only be dialed at their station. System Speed Dial numbers are assigned only by Station 10 (typically the system administrator's or operator's station), but can be used by other stations.

**To Store a Station Speed Dial Number:**

- |  |  |
|--|--|
| 1. Lift the handset.   | You will hear intercom dial tone after you lift the handset.   |
| 2. Dial <b>6 6</b> .   | You will hear a short tone after you dial <b>6 6</b> .   |
| 3. Dial <b># *</b> .   |  |
| 4. Enter the access code (1 0 ~ 4 9) where you wish to store the telephone number. | Station Speed Dial number access codes are 1 0 ~ 4 9.  |
| 5. Dial the CO line number access code to be stored.                               | CO line number access codes are 7 0 1 ~ 7 0 4 (for DK8) and 7 0 1 ~ 7 0 8 (for DK16). With some systems, you may have to dial either the general group code (9), Least Cost Routing (LCR) code (9), or a Line Group code (8 1 ~ 8 4 for DK8; 8 1 ~ 8 8 for DK16), instead of a CO line number access code. |
| 6. Enter the telephone number.   | The number can be up to 20 digits, including the CO line access code.  |
| 7. Dial <b>#</b> .   | You will hear confirmation tone. The CO line access code and the telephone number will be stored and will be dialed when you dial the Speed Dial access code.  |

Repeat this procedure to replace the stored telephone number with a new one.

**To Make a Call with a Station or System Speed Dial Code:**

- |                      |  |
|----------------------|--|
| 1. Lift the handset. | You will hear intercom dial tone after you lift the handset. |
|                      | You will continue to hear intercom dial tone.                |

**STRATA DK STANDARD TELEPHONE**

**FEATURE OPERATION**

2. Dial **\***.
3. Dial the 2-digit Speed Dial access code.

Station Speed Dial codes are 1 0 ~ 4 9, and System Speed Dial codes are 6 0 ~ 9 9. (Dial tone continues as you dial the access code.)

The system will automatically dial the telephone number assigned to the access code.

**TONE/VOICE FIRST SIGNALING**

Your STRATA DK system may be set for Tone Signaling or Voice First Signaling as the standard intercom call signaling method for calls to digital and electronic telephones. The Tone Signal consists of repetitive ring tones, while the Voice First Signal consists of a tone burst followed by the caller's voice. When you initiate a call, you can change to the alternate signaling method. Standard telephones always ring with Tone Signaling, no matter what the system signaling method.

**To Change the Signaling Mode:**

1. Call a digital or electronic telephone via intercom.
2. To change the mode, dial **1**.

If the signaling mode is set for Voice First Signaling, you will hear a single tone burst. If the signaling mode is set for Tone Signaling, you will hear repetitive ringback tone.

The call will begin to ring at the station, if you changed from Voice First Signaling to Tone Signaling.

If you changed from Tone Signaling to Voice First Signaling, the call will stop ringing and you will hear a tone burst. You can converse after the tone burst.

**CO LINE QUEUING**

CO Line Queuing enables you to be placed in a waiting queue for a CO line after dialing a line group in which all lines are busy. You will be called back when a line in the group becomes available.

**STRATA DK STANDARD TELEPHONE**

**FEATURE OPERATION**

**To Set CO Line Queuing:**

1. If all outgoing lines are busy, you will hear busy tone after dialing a CO line access code.
2. Dial **4**.
3. Hang up.
4. Your telephone will ring at a fast rate when a CO line becomes idle.
5. Lift the handset immediately.

The busy tone will stop when you dial 4. You will hear dial tone for two seconds, then the busy tone will resume.

You may make other calls while waiting for a line to become available.

Answer within two rings to prevent the callback from being cancelled.

You will hear CO dial tone. (If you hear busy tone, it means the line has already been seized or has received an incoming call. Your request is not cancelled. You will be called again the next time a line becomes idle.)

If the original call was made using Least Cost Routing (LCR) by dialing 9, the telephone number will be automatically dialed in Step 4.

**To Cancel CO Line Queuing:**

1. Lift the handset and dial **4 3**.

CO Line queuing will be cancelled.

**CALL PICKUP**

You can pick up a call that is ringing another station, a call placed on hold at another station, and other types of calls.

**To Use Call Pickup:**

1. Lift the handset and dial **5**.
2. Station—Dial a Station number to pick up a call that is ringing in at or on hold at the station.

You will be connected to the call ringing in or the held call.

**STRATA DK STANDARD TELEPHONE**

**FEATURE OPERATION**

Intercom page or ringing door phone—Dial **3 0**.  
... or ...

External page—Dial **3 5**.  
... or ...

While the CO line is on hold, dial the CO line access code (7 0 1 – 7 0 4 for DK8; 7 0 1 – 7 0 8 for DK16).  
... or ...

Any ringing CO line—Dial **9**.

You will be connected to the station where the page is coming from, or the door phone that is ringing.

You will be connected to the station where the page is coming from.

You will be connected to the CO line that is on hold.

You will be connected to the CO line that is ringing in.

**DIRECT INWARD SYSTEM ACCESS (DISA)**

Outside callers with telephones that send Dual-tone Multi-frequency (DTMF) tones (push-button dialing) can call in on CO lines programmed for DISA and dial stations or outgoing CO lines, without going through an attendant or operator.

**To Make a Direct Inward Station Call with DISA:**

1. From outside the system, call a DISA CO line telephone number: \_\_\_\_\_
2. Listen for the repetitive ringback tone signal, then listen for the intercom dial tone.
3. Dial the intercom number of the desired station.

See the system administrator for this number.

Try again if you hear busy tone.

Dial tone will be present for 10 seconds to allow direct dialing of a station intercom number or CO line access code. If a number is not dialed, the system automatically causes the DISA CO line to ring at telephones as a normal incoming call. Then, if the call is not answered within 15 seconds after the ringing starts it will disconnect.

You will be connected when the station answers.

If you receive busy tone or wish to dial another number while ringing the station, press the \* button to receive dial tone.

If the call is not answered after six rings or 24 seconds, whichever occurs first, busy tone will be sent. Dial \* to access dial tone, then dial the same or another number. To call another station after completing a DISA

**STRATA DK STANDARD TELEPHONE**

**FEATURE OPERATION**

station call, the internal party must transfer you. Station and System Page cannot be accessed on DISA calls.

**To Make an Outgoing Call with DISA:**

1. From outside the system, call a DISA CO line telephone number: \_\_\_\_\_
2. Listen for repetitive ringback tone, then listen for intercom dial tone.
3. Dial a CO line number or line group access code.
4. If a DISA security code is required, dial the code and listen for CO dial tone.  
... or ...  
If a DISA security code is not required, you will hear CO dial tone.
5. Dial a telephone number.

See the system administrator for this number.

Try again if you hear busy tone.

Dial tone will be present for 10 seconds to allow direct dialing of a station intercom number or CO line access code. If a number is not dialed, the system automatically causes the DISA CO line to ring at telephones as a normal incoming call. Then, if the call is not answered within 15 seconds after the ringing starts it will disconnect.

CO line number access codes are 7 0 1 ~ 7 0 4 (for DK8) and 7 0 1 ~ 7 0 8 (for DK16), and line group access codes are 8 1 ~ 8 4 (for DK8) and 8 1 ~ 8 8 (for DK16). The Least Cost Routing code (9) is not allowed.

If required, see the system administrator for this number. If the entered code is not correct, the call will be disconnected.

A timer tone that is audible to both parties will sound approximately four minutes after the call was made. Dial 0 to reset the timer each time the tone sounds for an additional four minutes. If you fail to dial 0, the call will disconnect approximately one minute after the tone.

**TOLL RESTRICTION OVERRIDE/TRAVELING CLASS**

You can completely override Toll Restriction at a station or change the station's Toll Restriction class to another level. The station will resume its normal class at the conclusion of the call. Use the following procedure to completely override or to change a station's Toll Restriction class.

**STRATA DK STANDARD TELEPHONE**

**FEATURE OPERATION**

**To Override/Change Toll Restriction:**

1. Dial a CO line number access code.
2. Flash the hookswitch and dial **4 7**.
3. Enter the Toll Restriction Override Code.
4. Dial a telephone number.

CO line number access codes are 7 0 1 ~ 7 0 4 (for DK8) and 7 0 1 ~ 7 0 8 (for DK16). Some systems may require instead that you dial 8 1 ~ 8 4 (for DK8) or 8 1 ~ 8 8 (for DK16) to access a CO line group or 9 to access a general CO line group or Least Cost Routing.

You will hear CO dial tone, unless you dial 9 with Least Cost Routing.

"Flash the hookswitch" by depressing the hookswitch (plunger) located in the handset cradle for about 1/2 second. (Some telephones may have a special button which flashes the hookswitch when pressed.)

You will no longer hear dial tone.

You will hear dial tone after you dial the last digit of a valid code.

For security reasons, the override codes are only available on a selected basis. See your system administrator.

The call will be allowed if the code entered in step 3 changes your telephone's Toll Restriction Class to allow the dialed number.

## Index

**STRATA DK STANDARD TELEPHONE**

**INDEX**

### A

Account Code Calls 1-9  
  Emergency Override of Forced  
  Account Code Dialing 1-10  
  Forced Account Codes 1-9  
  Verified Account Codes 1-11  
  Voluntary Account Codes 1-10  
Automatic Callback 1-2

### C

Call Forward 1-3  
Call Hold/Park 1-4  
Call Pickup 1-16  
Call Transfer with Camp-on 1-5  
CO Line Queuing 1-15  
Conference Calls 1-6

### D

Direct Inward System Access  
  (DISA) 1-17  
Door Phone 1-8

### F

Flash CO Line 1-9

### I

Intercom Calls 1-1

### M

Message Waiting Indication 1-11

### O

Outside Calls 1-1  
Override Calls 1-12

### P

Paging 1-12

### R

Repeat Last Number Dialed 1-13

### S

Speed Dial 1-14

### T

Toll Restriction Override/ Traveling  
Class 1-18  
Tone/Voice First Signaling 1-15

**TOSHIBA**

ADD-ON MODULE AND  
DIRECT STATION  
SELECTION CONSOLE  
USER GUIDE

BUSINESS  
TELEPHONE  
SOLUTIONS



STRATA® DK

DIGITAL KEY  
TELEPHONE SYSTEMS  
STRATA DK8 & DK16



## Table of Contents

STRATA DK ADD-ON MODULE / DSS CONSOLE

TABLE OF CONTENTS

SUBJECT	PAGE
<b>INTRODUCTION</b>	
General Description .....	iii
Add-on Module (ADM)—Strata DK8 and DK16 .....	iii
Direct Station Selection (DSS) Button—Strata DK16 Only .....	iii
Organization .....	iii
How to Use This Guide .....	iv
<b>CHAPTER 1</b>	
ADD-ON MODULE .....	
Feature Buttons .....	1-1
Button LED Indications .....	1-2
Calling a Station .....	1-2
Transfer To An Idle Station .....	1-3
Call Transfer With Camp-on .....	1-3
Speed Dial .....	1-4
All Call Page and Night Transfer .....	1-4
<b>CHAPTER 2</b>	
DSS CONSOLE .....	
Feature Buttons .....	2-1
DSS Console LED Indications .....	2-2
DSS Button Operation .....	2-2
All Call Page .....	2-3
Call Answering (CO Line or Intercom) .....	2-4
DSS Console Call Forward Override .....	2-4
Night Transfer .....	2-4
Date/Time/Day Adjustment .....	2-5
Date Setting .....	2-5
Time Setting .....	2-6
Day of the Week Setting .....	2-6

### FIGURE LIST

FIGURE	TITLE	PAGE
I-1	Sample Page .....	v
1-1	STRATA DK8 and DK16 Add-on Module Button Assignments .....	1-1
2-1	STRATA DK16 Initialized DSS Console Button Assignments .....	2-1

*This page intentionally left blank.*

## Introduction

### GENERAL DESCRIPTION

The Add-on Module (ADM) for Strata DK8 and DK16, and the Direct Station Selection (DSS) console for Strata DK16 enable you to process a heavy load of calls quickly and efficiently.

#### ADD-ON MODULE (ADM)—STRATA DK8 AND DK16

The ADM attaches to a 2000-series Digital Telephone to provide the following: For Strata DK8, it provides 10 DSS buttons, eight Speed Dial buttons, a Night Transfer button, and an All Call Page button. For Strata DK16, it provides 20 Direct Station Selection (DSS) buttons. With a DSS button, you can call a station or transfer outside calls to stations with just the push of a button. Each DSS button is associated with a particular station and has an LED which indicates whether the station is busy or idle.

#### DIRECT STATION SELECTION (DSS) CONSOLE—STRATA DK16 ONLY

The DSS console operates alongside a digital telephone (2000 or 1000 series), or an electronic telephone for a dedicated answering position. The DSS console has 60 buttons which allow immediate access to features frequently used by an attendant. In addition to having DSS buttons (like the ADM does), the DSS console may have CO line buttons, Speed Dial buttons, an All Call Page button, and a Night Transfer button.

### ORGANIZATION

This user guide is divided into the following sections:

The Introduction provides a general description of the Strata DK8 and DK16 ADM, and the DK16 DSS console. It also describes the organization of this user guide and offers suggestions on how to use it.

Chapter 1, "Add-on Module," contains a description and operating instructions for the ADM. The instructions explain how to access stations with the DSS buttons that appear on the ADM (as well as on the DSS console for Strata DK16). This chapter also provides an explanation of the DSS button LEDs/indications.

Chapter 2, "DSS Console," applies only to the Strata DK16 and contains operating procedures and an explanation of the LEDs/indications for the DSS console. (The DSS buttons on the DSS console operate like the DSS buttons on the ADM; so refer to Chapter 1 for DSS button operating

### HOW TO USE THIS GUIDE

Your DSS console's features are determined by assignments made in system programming. Your system administrator can provide details on DSS console button function assignments. Once you are aware of the features that are available to you, review each feature's description and operational procedure contained in this guide.

To assist you in achieving greater performance efficiency, the information in this user guide is divided into distinct areas of content. Instructions for various procedures are referred to as Action Text and appear in the left-hand column of the page. Instructions appear in numerical sequence, enabling you to quickly perform a specific task. More detailed descriptions of these procedures, or explanations of their effects, are located in the right-hand column. Figure I-1 shows you the structure followed for each feature.

It is recommended that you first read the user guide for your particular type of telephone. Once you understand the telephone operation, the terms in this user guide will be more clearly understood.

**ACTION TEXT**  
SPECIFIC INSTRUCTIONS ON HOW TO PERFORM A  
PROCEDURE ARE NUMBERED AND ENTERED IN  
THE LEFT-HAND COLUMN.

**NOTES AND  
WARNING  
MESSAGES**

STRATA DK ADD-ON MODULE / DSS CONSOLE		ADD-ON MODULE
		<b>TRANSFER TO AN IDLE STATION</b>
		<i>Transfer transfer outside calls to an idle station</i>
1 Press the <b>DSS</b> button corresponding to the station to be called.	The outside line is placed on hold automatically. The Low LED will flash upon activation of the on-hold tone, and the DSS LED will flash green.	
2 Answer the call. You do not have to press any other buttons.	You will hear a single ring tone (this procedure is written for the Voice First signaling mode; if using the Tone signaling mode instead, you would hear six consecutive ring tones).	
3 Hang up to transfer the call.	Wait. Later signaling, you would have to wait for the called station to answer before answering the call.	
	The outside line will ring the called station when you hang up. While the call is being ringing, the DSS LED will become steady red, and the Low LED will flash green at the on-hold rate.	
	When the called station answers the call, the DSS LED will stay steady red, and the Low LED will become steady red.	
	<b>NOTE</b> If the called station does not answer your call or busy, you can still transfer the call by hanging up. If the status does not answer before a period set in system programming, the outside line will recall you.	
		<b>CALL TRANSFER WITH CAMP-ON</b>
		<i>You can transfer an outside call to a busy station even though the LED of the <b>DSS</b> button associated with the busy station will be red before you try to transfer the call, via the <b>DSS</b> button to transfer the call.</i>
To transfer an outside call to a busy station:		
1 Press the <b>DSS</b> button corresponding to the busy station to be called.	You will hear a busy tone. The outside line will be placed on hold automatically. The Low LED will flash green at double the on-hold rate, and the DSS LED will remain steady red.	
	1-2	

CHAPTER TITLES

FIRST LEVEL HEADINGS

RESULTS OR DETAILS OR EXPLANATIONS OR DETAILS OF THE ACTION TEXT

Figure I-1  
Sample Page

# Chapter 1

## ADD-ON MODULE

This chapter provides operating procedures and information for the Add-on Module (ADM), model DADM2020, when it is attached to a digital 2000-series telephone operating with a Strata DK8 or DK16 system.

Figure 1-1 shows an illustration of the Strata DK8 and DK16 ADM button assignments. The Strata DK16 DSS button assignments are fixed and cannot be changed. The Strata DK8 button assignments for the following are also fixed and cannot be changed: DSS (10-19), Speed Dial (SD10-17), All Call Page, and Night Transfer button.

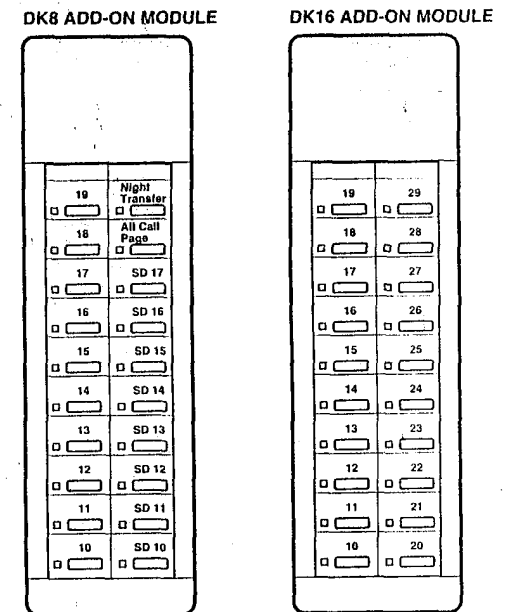


Figure 1-1  
Strata DK8 and DK16 Add-on Module Button Assignments



## FEATURE BUTTONS

For the Strata DK8 ADM, the Night Transfer button places the system in the Night mode, the All Call Page button accesses All Call Page, and the eight personal Speed Dial buttons provide one touch dialing of frequently used telephone numbers or feature access codes.

DSS buttons are used to call a station or transfer an outside call to a station. A label identifies the station associated with each DSS button.

The ADM for Strata DK16 is equipped with 20 Direct Station Selection (DSS) buttons. Each button has a label that identifies the station that is associated with the button. Only DSS buttons can appear on the Strata DK16 ADM.

## BUTTON LED INDICATIONS

A DSS button LED on the ADM will be green and flashing when calling or transferring an outside call to a station. (If calling a station, the LED will turn red and steady when the called station answers; if transferring to a station, the LED will turn red and steady when you hang up to complete the transfer.)

## CALLING A STATION

To call a station with a DSS button, only press the button associated with the station—Do not press the Intercom button on your telephone. A station call with a DSS button can be made on-hook or off-hook, and with Voice First signaling or Tone signaling. After pressing the button, treat the call like any other station call made with a digital or electronic telephone.

Each DSS button has an LED which indicates whether the associated station is idle or busy. The LED will be lit and red if the station is busy and not lit if idle.

## TRANSFER TO AN IDLE STATION

You can transfer outside calls to an idle station.

### To Transfer an outside call to an idle station:

1. Press the **DSS** button corresponding to the station to be called.
2. Announce the call. You do not have to press any other button.
3. Hang up to transfer the call.

The outside line is placed on hold automatically. The Line LED will flash green at double the on-hold rate, and the DSS LED will flash green.

You will hear a single ring tone. (If using the Tone signaling mode, you will hear successive ring tones.)

With Tone signaling, you would have to wait for the called station to answer before announcing the call.

The outside line will ring the called station when you hang up. While the called station is ringing, the DSS LED will become steady red, and the Line LED will flash green at the on-hold rate.

When the called station answers the call, the DSS LED will stay steady red, and the Line LED will become steady red.

### NOTE:

*If the called station does not answer your call in Step 2, you can still transfer the call by hanging up. If the station does not answer before a period set in system programming, the outside line will recall you.*

## CALL TRANSFER WITH CAMP-ON

You can transfer an outside call to a busy station. Even though the LED of the DSS button associated with the busy station will be red before you try to transfer the call, use the DSS button to transfer the call.

### To transfer an outside call to a busy station:

1. Press the **DSS** button corresponding to the busy station to be called.

You will hear a busy tone. The outside line will be placed on hold automatically. The Line LED will flash green at double the on-hold rate and the DSS LED will remain steady red.

2. Hang up.

The outside line will ring the called station once with the camp-on tone after you hang up. While the called station is receiving this tone, the Line LED will flash green at the on-hold rate, and the DSS LED will remain steady red.

When the called station answers the transferred call, the Line LED will become steady red. The DSS LED will remain steady red.

**NOTES:**

1. The call will recall you and camp-on is cancelled if the station does not pick it up within a pre-determined time. Repeat the procedure (if necessary).
2. You may reconnect to a transferred line (anytime before it is answered) by pressing the appropriate Line button.
3. You can use The Busy Override feature instead of Call Transfer with Camp-on. See the Digital or Electronic Telephone User Guide for details.

**SPEED DIAL**

(STRATA DK8 ONLY)

Refer to the *Strata DK8 & DK16 Digital Telephone User Guide* for instructions on using Speed Dial feature, as well as assigning numbers to the Speed Dial buttons. Only the ADM speed dial buttons (SD) are assigned personal speed dial numbers, from 10 - 17 only.

**ALL CALL PAGE AND NIGHT TRANSFER**

(STRATA DK8 ONLY)

Refer to the "Feature Buttons" section at the beginning of Chapter 2 in this guide for information on the All Call Page and Night Transfer feature buttons. Also see the "All Call Page" and "Night Transfer" sections in Chapter 2 of this guide for instructions on performing these functions.

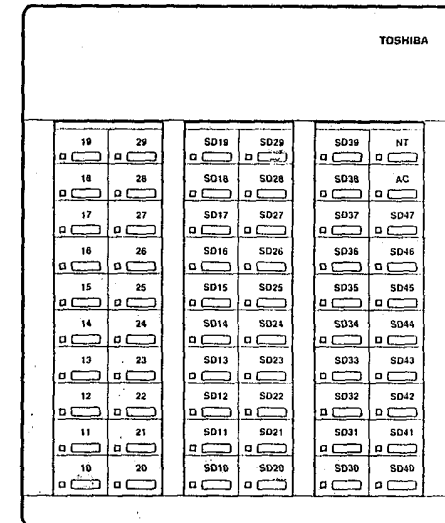
**Chapter 2**

**DSS CONSOLE**

(STRATA DK16 ONLY)

This chapter includes operating procedures and information for the following types of Direct Station Selection (DSS) console models: DDSS2060, DDSS1060, and HDSS6560.

These DSS console models look slightly different from each other, but the only operational difference between the consoles is the LED color indications, as noted in the "DSS Console LED Indications" section later in this chapter. Figure 2-1 shows an illustration of a DSS console.



Console button assignments for the DK16 are flexible and may be changed by service personnel.

**Figure 2-1**  
Strata DK16 Initialized DDSS Console Button Assignments (DDSS2060 shown)

## FEATURE BUTTONS

The DSS console has 60 buttons which can be assigned with any of the following features:

### All Call Page

Press the **All Call** (or **AC**) button to page a group of telephone speakers assigned in system programming.

### Night Transfer

Press the **Night 1** (or **NT**) button to change the ringing pattern of incoming calls.

### CO Line Access

Press a **Line** (or **CO**) button to answer an incoming call or to seize a CO line to make an outgoing call.

### Direct Station Selection (DSS)

Press a **DSS** button to transfer an outside call to a station or to make a call to a station. The label of each **DSS** button is designated by the intercom number of the station to which it is assigned. (See Chapter 1 for **DSS** button operation with the DSS console, as well as with the Add-on Module.)

### Speed Dial

Press a **SD** button to speed dial a telephone number or feature access code(s) assigned to the button. **SD** buttons can be either for System Speed Dial numbers or Station Speed Dial numbers. Refer to the *Strata DK8 & DK16 Digital Telephone User Guide* for instructions on assigning Speed Dial numbers and for feature access codes.

## DSS CONSOLE LED INDICATIONS

The button LEDs on the DDSS2060 and the DDSS1060 DSS console models light as red or green. The LEDs will light green during the following conditions:

- A Line (CO) button LED will be green and winking when the CO line is in-use by the console user.
- A DSS button LED will be green and flashing when calling or transferring an outside call to a station. (If calling a station, the LED will turn red and steady as soon as the called station answers; if transferring to a station, the LED will turn red and steady as soon as the DSS console attendant hangs up to complete the transfer.)

The LEDs will light red during all other conditions. The LEDs of the HDSS6560 model DSS console are always red when lit, no matter what the condition. Status distinctions are indicated by different flash rates.

### NOTE:

*The LED color indications described in this chapter apply specifically to the DDSS2060 and DDSS1060 models. Flash conditions described in this chapter apply to all three DSS console models.*

## DSS BUTTON OPERATION

The DSS buttons on the DSS console operate the same way as they do on the Add-on Module. See Chapter 1 for DSS button operating instructions for the following features:

- Calling a Station
- Transfer to an Idle Station
- Call Transfer with Camp-on

## ALL CALL PAGE

You can deliver a page to a group of station telephone speakers selected in system programming with the touch of a button on the DSS console.

### To deliver an All Call Page announcement:

1. Lift the telephone handset.
2. If on a CO line, press the **Hold** button on the telephone.
3. Press the **All Call** button on the DSS console.
4. Make your announcement in a normal voice level.
5. Hang up when you have completed your announcement.

The All Call LED will light steadily and be red.

The LED will turn off.

### CALL ANSWERING (CO LINE OR INTERCOM)

Use the same procedures as with a digital or electronic telephone. See the *Digital or Electronic Telephone User Guides* for more details.

### DSS CONSOLE CALL FORWARD OVERRIDE

Either your telephone or your DSS console can be set in system programming to ring stations that are in the Call Forward mode, instead of being forwarded. Typically, manually dialing from the telephone overrides the call forward feature. Among other applications, this feature can be used to notify a person who forgets to deactivate the Call Forward feature after returning to the office.

To override Call Forward with your telephone dialpad (typical program setting):

1. Call the station set for Call Forward by dialing from your telephone.

or, if system programming allows:

To override Call Forward with your DSS console:

1. Call the station set for Call Forward by pressing the associated **DSS** button on your DSS console.

Make this call like you would any other station call.

Your call will forward if you attempt to call the station by pressing a DSS button on the DSS console.

Your call will forward if you attempt to call the station by dialing from your telephone.

### NIGHT TRANSFER

At night, or at different times of the day, you can make the system ring different telephones for incoming calls. The set of telephones ringing is referred to as a ringing pattern.

Different ringing patterns are chosen by pressing the Night button (or the Night 1 or Night 2 button; see notes that follow). Each ringing pattern has distinct CO line-to-station ringing assignments.

Depending upon system programming, either two or three ringing patterns are available. The active pattern is shown by the state of the Night button LED:

	Two-pattern	Three-pattern
DAY	OFF	OFF
DAY 2	N/A	FLASH
NIGHT	ON	ON

#### NOTES:

1. For Non-tenant Service: The ringing state can be changed by any DSS console(s).
2. For Tenant Service: CO lines are assigned and controlled independently:  
**Night 1, TENANT 1 CO Lines**  
**Night 2, TENANT 2 CO Lines**
3. In Tenant Service, one system is split so two businesses can use their telephones independently of each other.

### DATE/TIME/DAY ADJUSTMENT

This operation is possible from Station 10 (usually), which must always be a Digital telephone for Strata DK8 or DK16. Station 10 is typically an attendant station with an Add-on Module (ADM) or DSS console (DK 16 only).

#### DATE SETTING

#### To set the Date:

1. Make sure the handset is on-hook.
2. Press the **Intercom** button and dial **6 5 1**.
3. Enter the date in the "YYMMDD" format.
4. Press the **Redial** button.

Listen for confirmation tone.

YYMMDD = Year/Month/Day. Enter a leading 0 for any single digit entered. Example: To enter January 2, 1993, enter "930102".

**TIME SETTING**

**To set the Time:**

1. Make sure the handset is on-hook.
2. Press the **Intercom** button and dial **6 5 2**.
3. Enter the time in the 24-hour clock format (HHMMSS).
4. Press the **Redial** button.

Listen for confirmation tone.

HHMMSS = Hour/Minutes/Seconds. Enter a leading 0 for any single digit entered. Example: To enter 1:30 p.m and 07 seconds, enter "133007".

**DAY OF THE WEEK SETTING**

**To set the Day of the Week:**

1. Make sure the handset is on-hook.
2. Press the **Intercom** button and dial **6 5 3**.
3. Enter the code representing the day that you wish to set:
4. Press the **Redial** button.

Listen for confirmation tone.

Use the following codes in Step 3 for setting the day of the week.

- 1 = Sunday
- 2 = Monday
- 3 = Tuesday
- 4 = Wednesday
- 5 = Thursday
- 6 = Friday
- 7 = Saturday

4. Privacy Override

```
NO. NN
YY PRV OVRD
```

When a station presses a busy line button to enter an existing conversation, the station number (YY) that initiates the override displays the Central Office (CO) line identification on the LCD. The overridden station's LCD displays the initiating station's number. (The display remains until the end of the call.)

Recalling Station:

```
HOLD LINE 2
LN 2 RECALL NN
```

When a transferred call goes unanswered, it will recall to the station that transferred it. The display shows the Central Office (CO) line number and the station number to which it was originally transferred.

Speed Dial Memo:

```
*11 TOSHIBA
7145833700
```

When using Speed Dial Memo (Mode 8), the name and number are displayed.

TOSHIBA is the memo (up to 12 characters).  
714 583 3700 is the number (up to 16 digits).

Toll Restriction Override Codes:

```
NO. NN
OVERRIDE CODE
```

After you access a Central Office (CO) line and press **Cnf/Trn 4 7** to dial a complete toll restriction override or traveling class code, your LCD display will prompt you to dial a code.

Two-CO Line Calls:

1. Tandem

```
TRK-TRK X1 X2
JAN 10 THU 11:57
```

After you establish a two-Central Office (CO) line conference call and then release, X<sub>1</sub> and X<sub>2</sub> identify the connected CO lines.

2. Conference

```
NO. NN
CONF LINE X1 X2
```

When you are talking with two external parties on two CO lines, X<sub>1</sub> and X<sub>2</sub> identify the connected CO lines.

## Chapter 2

### DATE/TIME/DAY ADJUSTMENT

This operation is possible from port 00 only (usually station 10), and allows you to set the date, time, and day.

**To Set the Date:**

1. Place handset on-hook.
2. Dial **Intercom 6 5 1**.
3. Dial the date
4. Press the **Redial** button.
5. Press the **Spkr** button.

Dial year/month/day in the format YYMMDD. Enter a leading 0 for any single-digit month or day.

You will hear a confirmation tone.

**To Set the Time:**

1. Place handset on-hook.
2. Dial **Intercom 6 5 2**.
3. Dial the time
4. Press the **Redial** button.
5. Press the **Spkr** button.

Dial hour/minute/second in the 24-hour clock format HHMMSS. Enter a leading 0 for any single digit entered.

You will hear a confirmation tone.

**To Set the Day:**

1. Place handset on-hook.
2. Dial **Intercom 6 5 3**.
3. Dial the day.

- 1** = Sunday
- 2** = Monday
- 3** = Tuesday
- 4** = Wednesday
- 5** = Thursday
- 6** = Friday
- 7** = Saturday

4. Press the **Redial** button.
5. Press the **Spkr** button.

You will hear a confirmation tone.

## CALL FORWARD DISPLAY

### TO SET CALL FORWARD

When any type of call forward is initiated, the "CALL FORWARD TO" prompt displays on the lower row of the LCD.

When your station has call forward set, the LCD displays as shown (NN = the forward-to number).

1. Call Forward-All Calls

```
CF-AC TO: STNN
JAN 26 TUE 01:43
```

Press **Intercom 6 0 1 + NN + Spkr**  
(or **Call Frwd All Calls + NN + Call Frwd All Calls**).

2. Call Forward-Busy

```
CF-BUSY TO: STNN
JAN 26 TUE 01:43
```

Press **Intercom 6 0 2 + NN + Spkr**  
(or **Call Frwd Busy + NN + Call Frwd Busy**).

3. Call Forward-No Answer

```
CF-NA TO: STNN
JAN 26 TUE 01:43
```

Press **Intercom 6 0 3 + NN + Spkr**  
(or **Call Frwd No Answer + NN + Call Frwd No Answer**).

4. Call Forward-Busy/No Answer

```
CF-B/NA TO: STNN
JAN 26 TUE 01:43
```

Press **Intercom 6 0 4 + NN + Spkr**  
(or **Call Frwd Busy NAns + NN + Call Frwd Busy NAns**).

5. Call Forward-Fixed

```
CF-FIXED TO: STNN
JAN 26 TUE 01:43
```

Press the **Call Frwd to:** button.

### NOTES:

1. To cancel call forward, press **Intercom 6 0 1 Spkr** (or press the call forward button used to set call forward).
2. If call forward is set:
  - Central Office (CO) lines that ring at your station only will forward (CO lines that ring into more than one station will not forward).
  - CO line calls transferred to your station will forward.
  - Intercom calls will forward.
  - Call forward redirects the station hunt feature.

## STATION-TO-STATION MESSAGE WAITING

### To Use Station-to-Station Message Waiting:

1. Lift the handset.
2. Dial the desired station number.
3. The called station user presses the **Intercom** and **Msg** buttons to return the call.
4. To clear the Msg LED from the called station, press the **Msg** button.
5. To clear the Msg LED from the calling station, press the **Intercom** button, dial the station number and press the **Msg** button twice (or **7 7**).

If there is no answer (busy or DND), press the **Msg** button (or dial **7**). This causes the Msg LED on the called station to flash. The called station's LCD displays the calling station's number.

When the returned call is answered, the flashing Msg LED will turn off.

### NOTE:

Up to four message waiting displays may be stored on the LCD. The station number in the left-most position will be called when the **Msg** button is pressed. To rotate the station numbers, press the **Scroll** button. The fourth message is reserved for the Message Center.

### VOICE MAIL (VM)

Whenever your station is call forwarded to voice mail, certain digits will automatically be sent to the voice mail unit to direct the call to your mailbox. These codes must only be stored one time; they remain in memory until changed. They do not have to be stored each time you Call Forward your telephone.

#### Assigning a mailbox to store messages:

1. Press the **Intercom** button.

Setting your mailbox number (where calls will go when you forward to the Toshiba VP voice mail system).

2. Dial **6 5 6**.

6 5 6 ID CODE SET

The LCD displays "6 5 6 ID CODE SET".

3. Dial the digits (up to 16) and pauses to be sent.

The LCD displays the digits and pauses. These digits include special voice mail codes and your mail box number. For example, for Toshiba VP Systems dial 91NN, where NN is your mail box number.

4. Press the **Redial** button to store data.

DATA PROGRAMED

You will hear a confirmation tone—the LCD displays "DATA PROGRAMED".

#### Assigning a mailbox for message retrieval:

1. Press the **Intercom** button.

When you want to retrieve your messages from voice mail, certain digits will automatically be sent to the voice mail unit to play back your messages.

2. Dial **6 5 7**.

The LCD displays "6 5 7 ID CODE SET".

3. Dial the required digits and pauses to be sent.

The LCD displays the data as it is entered. These digits include special voice mail codes and your mail box number. For example, for Toshiba VP Systems dial 92NN##, where NN is your mail box number.

4. Press the **Redial** button to store data.

You will hear a confirmation tone—the LCD displays "DATA PROGRAMED".

#### To Retrieve Messages:

Press the **Intercom** and **Msg** buttons.

The Msg LED must be flashing to allow message retrieval.

#### To Clear All VM ID Digits:

1. Press the **Intercom** button.
2. Dial **6 5 6** or **6 5 7**.
3. Press the **Redial** button.

#### To Display Busy Field Status:

1. Press the **Mode** button.

MODE NO. ?

### BUSY FIELD DISPLAY

The LCD displays "MODE NO.?" Your telephone must be idle to use the **Mode** button when Soft Keys are turned ON.

#### NOTE:

The Busy Field mode will stop all other displays from appearing on your telephone LCD.

2. Dial **1**. Refer to the figure in *Summary of LCD Functions*.

### MODE EXIT

#### To Exit Any Mode:

1. Press the **Mode** button.
2. Dial **0**.

The LCD displays "MODE NO.?" Your telephone must be idle to use the **Mode** button when Soft Keys are turned ON.

The LCD displays date/day/time.

### DISA SECURITY CODE: ADD/DELETE/CHANGE

Direct Inward System Access (DISA) security codes can be added, deleted, and changed from designated station(s) only. For security purposes, the 3-digit access code is not given in this guide. It is available from your telephone system administrator.



**STRATA DK DIGITAL LCD TELEPHONE**

**FEATURE OPERATION**

**To Change/Delete the DISA Security Code:**

1. Press the **Intercom** button and dial the 3-digit access code.

NO. NN  
 000 ID CODE SET

2. Dial the new DISA security code.

3. Press the **Redial** button.

NO. NN  
 DATA PROGRAMMED

4. To cancel the DISA code, complete Steps 1 and 3, skipping Step 2.

You will hear a confirmation tone.

The DISA security code can be 1 ~ 15 digits. The LCD displays the new code as it is dialed.

You will hear a confirmation tone.

If the DISA code is canceled, outgoing access of CO lines on DISA calls will not require a security code.

**TOLL RESTRICTION OVERRIDE/TRAVELING CLASS CODE CHANGE**

**To Add, Delete, or Change Override/Traveling Class Codes:**

1. Press **Intercom** and dial the three-digit toll restriction override change access code.

NO. NN  
 ENTER OVR. CODE

To add, delete, or change override for Traveling Class Code, these steps must be performed from a station that was selected in system programming.

You will hear a confirmation tone.

You should hear a dial tone. For security reasons, the change access code is not provided in this guide. It is available from your telephone system administrator.

**STRATA DK DIGITAL LCD TELEPHONE**

**FEATURE OPERATION**

2. Dial the four-digit override code.

NO. NN  
 ENTER OVR CODE 0000

3. Press the **Redial** button to store the code.

NO. NN  
 DATA PROGRAMMED

4. Repeat steps 1 ~ 4 to enter up to four traveling class codes or two toll restriction override codes.

5. To delete a code, complete steps 1 and 3, skipping step 2.

**VERIFIED ACCOUNT CODE CHANGE**

**To Add, Delete, or Change Verified Account Codes:**

1. Press **Intercom** and dial the verified account code change access code.

NO. NN  
 VERIFY ACC SET

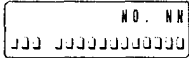
2. Dial the three-digit verified account code number (000 ~ 099 for DK8, 000 ~ 299 for DK16).

NO. NN  
 VERIFY ACC SET 000

To add, delete, or change a verified account code, these steps must be performed from a station that was selected in system programming.

For security reasons, the change access code is not provided in this guide. It is available from your telephone system maintenance provider.

3. Dial the verified account code (4 - 15 digits).



The account code digit length is set in system programming.

The new verified account code displays as the digits are dialed.

4. Press the **Redial** button to store code.



You will hear a confirmation tone.

5. Repeat steps 1 - 4 to enter more verified account codes.
6. To delete a code, complete steps 1, 2, and 4, skipping step 3.

## Chapter 3

### GENERAL DESCRIPTION

The Soft Key feature provides a quick and easy way to access frequently-used features. If the Soft Key feature is activated at your station, abbreviated feature prompts will appear on the LCD above the **Mode**, **Page**, and **Scroll** keys while you are on a call (or you are ringing another station or outside telephone number). You can access the feature represented by the feature prompt just by pressing the **Mode**, **Page**, or **Scroll** key beneath the prompt.

If the Soft Key feature is activated at your station, you can still access features with feature buttons (fixed or flexible) or with access codes.

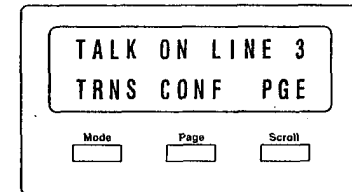
When your telephone is idle, Soft Keys do not display and the **Mode**, **Page**, and **Scroll** keys function as normal. If your telephone is in use, Soft Key functions replace the **Mode**, **Page**, and **Scroll** functions.

### HOW TO USE SOFT KEYS

This section provides an example of how to use Soft Keys to make a Conference call by adding a station to an outside call. Other features that can be accessed with Soft Keys include Transfer, Paging, and more.

#### USING SOFT KEYS TO MAKE A CONFERENCE CALL

1. While on an outside call with CO line (line 3 for this example) your LCD will display the following prompts:



**NOTE:**

Once the Soft Key prompts appear (in this case, the Soft Keys are TRNS, CONF, and PGE for Transfer, Conference, and Page), the buttons below them now stand for Transfer, Conference, and Page instead of **Mode**, **Page**, and **Scroll**. In the following steps of this example, only the Soft

**STRATA DK DIGITAL LCD TELEPHONE**

**SOFT KEY OPERATION**

Key displays will be shown since **Mode**, **Page**, and **Scroll** no longer apply while Soft Keys are active.

- If you initiated the call, the "TRNS" prompt will appear 30 seconds after the first digit of the telephone number is dialed—the "ABR" prompt for Automatic Busy Redial (ABR) will appear during this first 30 seconds (if it does not appear, then ABR was not assigned to your station in system programming). If the call is an incoming call, the "TRNS" prompt will appear immediately when you answer the call.

2. Press the **CONF** Soft Key to initiate the Conference.

TALK ON LINE 3  
TRNS CONF PGE

- The outside call will be placed on hold and the LCD will appear as follows in step 3 after you press the **CONF** Soft Key in Step 2.

3. To conference with a station, press the **STA.** Soft Key.

LINE OR STATION?  
LINE STA. RTRN

- Whenever the **RTRN** Soft Key appears, you can terminate the operation and return to the outside call by pressing the **RTRN** Soft Key.

4. Dial a station number when the following LCD appears:

DIAL STATION NO.  
RTRN

**STRATA DK DIGITAL LCD TELEPHONE**

5. After you dial one of the displays, then change to

CALLING  
ST 12

Called station (1 name) turned off.

6. After three seconds following display

- You could stop 12 ring by pressing
- Instead of proceeding by pressing
- You could terminate by pressing the R

7. The LCD will appear when the station is on hold. Press the

- Instead of proceeding by pressing
- You could terminate by pressing the R

8. The LCD will appear as follows after you press the JOIN Soft Key in Step 7 and all parties will be conferenced.

LN3+ST12  
EXIT CONF

- "LN 3 + ST12" indicates that you are in a Conference with CO line 3 and Station 12.
- You can exit the Conference and the other parties will remain connected if you press the EXIT Soft Key.
- You can add another station or CO line by pressing the CONF Soft Key.

**NOTE:**

*If the Soft Key feature is activated at your station, incoming call information will not display on your LCD while your station is busy. To display this information, you must either disconnect the existing call or place it on hold.*

**SOFT KEY PROMPT DEFINITIONS**

The following list provides definitions of all of the Soft Key prompts that could appear on your LCD.

**TRNS**—Press this Soft Key to initiate or complete a Transfer while on an outside call. TRNS can cause an immediate or announced transfer, depending on how the feature is set in system programming.

**CONF**—Press this Soft Key to initiate or complete a Conference.

**PGE**—Press this Soft Key to park an outside call and to gain access to a menu of Page options.

**RING**—Press this Soft Key to make a called station ring when making a voice announce call to the station.

**TALK**—Press this Soft Key to make a voice announcement to a called station that is ringing.

**MESG**—Press this Soft Key to set a message waiting indication at a busy or unanswered station.

**OVRD**—Press this Soft Key to gain access to override options or to override a station that is busy or in the Do Not Disturb mode.

**BUSY**—(Busy Override) Press this Soft Key to send a call-waiting tone to a busy station. If the called busy station is equipped with Off-hook Call Announce (OCA), that station will receive OCA warning tone and your announcement.

**EXEC**—(Executive Override) Press this Soft Key to break into the conversation of a busy called station.

**ACB**—Press this Soft Key to activate Automatic Callback after reaching a busy or DND station, CO line, or CO Line group.

**ABR**—Press this Soft Key to activate Automatic Busy Redial after dialing a busy outside telephone number.

**RLS**—Press this Soft Key to disconnect a call and to return to the idle state.

**RTRN**—Press this Soft Key to terminate a feature operation and to return to a previously displayed state.

**LINE**—Press this Soft Key to add a CO line to an existing call while in the Conference mode. The LCD will prompt you to access a CO line after you press this key.

**STA**—Press this Soft Key to add a station to an existing call while in the Conference mode. The LCD will prompt you to dial a station number after you press this key.

**JOIN**—Press this Soft Key while on a conference call to join all parties to a Conference.

**EXIT**—Press this Soft Key to exit from a Conference and to leave the remaining parties connected.

### SOFT KEY ACTIVATION

To activate Soft Keys at your station:

1. Make sure your telephone is idle. Do not lift the handset.
2. Press the **Mode** key below the LCD.
3. Dial **7 1**.

Your telephone must be idle before you follow the steps on the left to activate or deactivate the Soft Key feature at your station.

Soft keys are now activated and the appropriate feature prompts will display when your phone is in use. The Soft Key feature will remain on until you turn it off. In other words, you can perform numerous telephone functions and the Soft Keys will not be cancelled unless you deactivate them.

### SOFT KEY DEACTIVATION

To deactivate Soft Keys at your station:

1. Make sure your telephone is idle. Do not lift the handset.
2. Press the **Mode** key below the LCD.
3. Dial **7 0**.

Your telephone must be idle before you follow the steps on the left to activate or deactivate the Soft Key feature at your station.

Once you deactivate the Soft Keys, the feature prompts will no longer appear on the telephone display.

## Chapter 4

### LCD ALPHANUMERIC MESSAGES, NAMES, MEMOS

The LCD on your telephone can be used to send or receive messages to or from other LCD telephone users. The LCD can also display the names/numbers of the person calling your telephone or the name of the person you are calling. Names and memos can also be set to display with speed dial numbers and timed reminders.

### STORING A MESSAGE IN MEMORY

To Store a Message in Memory:

1. Press the **LCD Msg Select** (or **Intercom 6 B**) button.

MSG NO. ?

The LCD Msg Select LED flashes.

2. Dial the 2-digit message number to be stored.
3. Use the Recording a Message procedure to enter the message characters.
4. Press the **LCD Msg Select** (or **Spkr**) button.
5. Press the **LCD Msg Select** (or **Intercom 6 B Spkr**) button.

Personal message (10 ~ 19); system message (60 ~ 99). System messages can be set from only one station, usually station 10. The current message, if any, will be displayed.

Refer to the Record a Message procedure following this procedure.

The LCD Msg Select LED lights steadily, and the LCD displays the message. The message will now be stored in system memory.

The LCD Msg Select LED goes out, and the message will no longer appear on the LCD, but it will remain in memory. It can be recalled by steps 1 and 2 of this procedure.

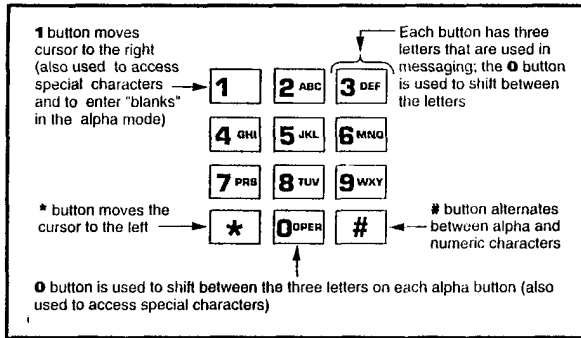
### RECORDING A MESSAGE

#### RECORDING A MESSAGE, NAME, OR MEMO

Use this procedure to enter the characters of user name, speed dial memo, timed reminder memo, or a personal message (10 ~ 19) or system message (60 ~ 99), to add to a preprogrammed message, or to edit and set a new message. After calling up a message on your display (see Storing a Message in Memory, Steps 1 and 2 above), perform one of the following procedures:

**To Record a Message:**

1. Press the # button to access alpha characters. Refer to Figure 4-1 for an explanation of the dialpad buttons.
2. Press \* or 1 to move the cursor (-) to the desired position (the left edge of the display for a new message, or two spaces to the right of the preprogrammed message to add information).



**Figure 4-1**  
**Dialpad Information**

3. Press the button that has the letter you want to enter. Use the 0 button to shift from letter to letter on the button.
4. If you want to enter a number, press the # button to change to numeric characters. Numbers are also entered on the dialpad. Press the # button again to return to alpha characters.
5. The following special characters are set by pressing 1 and then pressing 0 to step through the available characters:

Q, Z, :, -, +, /.

Example: If you press 3, a "D" will be displayed. By pressing 0, the "D" is changed to "E". By pressing 0 again, the "E" is changed to "F". Press 0 again and the "F" changes to "D".

To enter a space, press 1 when in the alpha mode.

**PREPROGRAMMING SYSTEM MESSAGES**

System messages can only be programmed or permanently changed at station number \_\_\_\_\_ (usually 10). Five preprogrammed messages are automatically stored in memory when the Alphanumeric Messaging with LCD feature is initialized.

- 60) OUT TO LUNCH
- 61) IN A MEETING
- 62) CALL \_\_\_\_\_
- 63) BACK AT \_\_\_\_\_
- 64) RETURN ON \_\_\_\_\_

You can use these messages and add 35 more messages designed specifically for your system, or you can overwrite the initialized messages and program up to 10 of your own. Any messages programmed will remain in memory until canceled or until the system is reinitialized. After reinitialization, only the original five messages will be in memory. System messages are written and stored in memory as explained in Storing a Message.

**ADDING TO PREPROGRAMMED MESSAGES**

When you select a message, it appears on your station display. A cursor (-) also appears immediately to the right of the last letter in the message. You can now input additional information (up to a total of 32 digits for each message). Some system messages may expect you to add more information. For example:

1. CALL \_\_\_\_\_  
  - Add a station or outside telephone number.
2. BACK AT \_\_\_\_\_  
  - Add the time you will return.
3. RETURN AT \_\_\_\_\_  
  - Add the date you will return.

**NOTE:**

Refer to Recording a Message for adding to a preprogrammed message.

**MESSAGING**

**CALLING STATION MESSAGING**

You can set a message that will appear on the LCD of telephones that call your telephone by following the instructions on the left.

**To Create an LCD Message for Phones that Call Yours:**

1. Press the **LCD Msg Select** button (or **Intercom 6 8**).

MSG NO. ?

2. Dial the number of the message you want.

3. Press the **LCD Msg Select** (or **Spkr**) button.

The LCD Msg Select LED flashes, and the LCD displays "MSG NO.?"

Personal message (10 ~ 19) and system message (60 ~ 99). The selected message is displayed. (To add to this message, use the procedure for "Recording A Message," found earlier in this chapter.)

The LCD Msg Select LED lights steadily, and the selected message will be set. The message will be sent to LCD telephones that call your telephone.

**CANCELLING A CALLING STATION MESSAGE**

**To Cancel a Message that Has Been Set at Your Station:**

Press the **LCD Msg Select** button.

The LCD Msg Select LED goes out.

**To Cancel a Message if You Do Not Have a LCD Msg Select Button:**

1. Press the **Intercom** button.
2. Dial **6 8**.
3. Press the **Spkr** button.

The Intercom LED lights.

The Intercom LED goes out. A personal message (10 ~ 19) will remain stored in memory. Preprogrammed messages (60 ~ 99) are never erased; only user-added messages are erased.

**SETTING/CHANGING CALLING STATION MESSAGES**

You can set a completely new, personalized message by overwriting any of the existing preprogrammed messages. To do this, simply call up one of the messages as explained previously. When the cursor appears to the right of the message, shift it to the left margin and write your new message over the preprogrammed one. The new message will remain on your station until canceled. It will then be erased and the original preprogrammed message will be restored.

**NOTES:**

1. Refer to Recording a Message for leaving a new message at your station.
2. Messages 10 ~ 19 will remain in memory until changed. The preprogrammed messages (60 ~ 99) are never erased; only the user-added messages are erased.

**STORING LCD NAME/NUMBER DISPLAY**

This feature allows you to use your telephone to store a title (such as your name, telephone number, location, etc.) in system memory. This title (e.g., LOBBY) will display on your station's LCD while it is idle, and it will appear at other stations' LCDs when they are called from your station. Your NAME will display on other telephone LCDs when they are used to call your telephone (Soft Keys must be turned on). Name display information for non-LCD telephones or voice mail/auto attendant devices may be stored from only one station, usually station 10. When NAME/NUMBER is recorded for non-LCD telephones or other devices, their NAME/NUMBER is displayed on LCD telephones when called.

**To Enter Name/Number Information:**

1. Press the **Intercom** button and dial **6 2 1**.

USER NAME ?

2. Enter the new information via the dialpad (refer to Recording a Message for method).

"USER NAME?" will appear on the upper line of the LCD.

Current information will appear on the lower line of the LCD.

Up to 16 characters can be recorded. It is recommended that you enter the station number along with the user's name (such as shown in Step 3).

**STRATA DK DIGITAL LCD TELEPHONE**

**MESSAGES AND MEMOS**

3. Press the **Spkr** button.

```
TOSHIBA EXT. 10
DATE DAY TIME
```

The new information is stored and will appear on the top line of the display. For example, if you entered "TOSHIBA EXT. 10," that will appear above the date/day/time on the display.

**To Clear Name/Number Display:**

Press the **Intercom** button, dial **6 2 0** and press the **Spkr** button.

During clear:

```
NO. NN
USER NAME RESET
```

After clear:

```
NO. NN
DATE DAY TIME
```

You will hear a confirmation tone, then a busy tone.

**NOTES:**

1. Your title will appear on the LCD during direct intercom, forwarded, and hunted calls. On override or OCA calls, the LCD will not display the title.
2. After a name is cleared, it may be redisplayed at any time by dialing **Intercom 6 2 1**.
3. A name is displaced by message and call forward settings if they are set.
4. To erase NAME/NUMBER information from memory, repeat Steps 1 ~ 3 above and enter blanks in Step 2. Blanks are entered by pressing **1** in the alpha mode.

**To Enter Name/Number Information for Other Stations/Devices:**

1. Turn off Soft Keys by pressing **Mode 7 0**, when telephone is idle.
2. Press the **Intercom** button and dial **6 2 1**.

```
USER NAME?
```

Entering Name/Number information for other stations or devices is only allowed from one station, usually station 10.

"USER NAME?" will appear on the upper line of the LCD. Current information will appear on the lower line of the LCD.

3. Press the **Page** button.

```
DEST EKT NO.?
```

The LCD displays "DEST. EKT NO.?" In this case, EKT stands for the intercom number of the digital, electronic or standard telephone.

**STRATA DK DIGITAL LCD TELEPHONE**

**MESSAGES AND MEMOS**

4. Dial the intercom number (N N) of the station for which the NAME/NUMBER information is to be recorded.

```
DEST EKT NO. NN
```

5. Press the **Page** button.

```
USER NAME?
```

"USER NAME?" will appear on the upper line of the LCD, and current information for station NN will appear on the lower line of the LCD.

6. Enter the new information via the dialpad (refer to Recording a Message for method).

Up to 16 characters can be recorded. It is recommended that you enter the station number along with the user's name.

7. Press the **Spkr** button.

The new information is stored and appears on the top line of station NN's LCD. Station 10's LCD returns to the normal idle display.

8. Repeat steps 2 ~ 7 to enter more names/numbers.

9. To turn Soft Keys on, press **Mode 7 1** when your telephone is idle.

**NOTES:**

1. To erase the NAME/NUMBER information of another station, repeat Steps 1 ~ 6 above and enter blanks in Step 5. Blanks are entered by pressing **1** in the alpha mode.
2. Station NN may set and clear the NAME/NUMBER feature anytime:
  - Set: **Intercom 6 2 1**.
  - Clear: **Intercom 6 2 0**. "Clear" eliminates the display when calling, but does not erase it from memory.

**SPEED DIAL MEMO**

This feature allows an LCD user to program a 12-character name for each of his/her 40 personal speed dial numbers. The memo pad of names may be stepped through to select the appropriate party. Memos may also be added to the 40 system speed dial codes via station number \_\_\_\_\_ (usually 10).



**STRATA DK DIGITAL LCD TELEPHONE**

**MESSAGES AND MEMOS**

**To Program Speed Dial Names and Numbers:**

1. Press the **Redial** button, then the **Speed Dial** button.
2. Dial the desired speed dial code.

# NN SPEED DIAL

Press **SDS** or **\*** if your telephone is not equipped with a **Speed Dial** button.

NN = Speed Dial Code. (10-49 station) or (60-99 system station 10 only)

**NOTE:**  
A station must be enabled via system programming for LCD message memory.

3. Press the **Mode** button.

\* 10 NAME  
SPEED DIAL

If a name was previously stored on this code, it will display on the top line of the LCD.

4. Enter the name or memo (12 character maximum - refer to Recording a Message for method).
5. Press the **Mode** button.
6. Enter the desired telephone number (20 digits maximum).
7. Press the **Redial** button to record data in memory.
8. Repeat steps 2-7 to enter more memos.

The name will appear on the top line of the LCD as you enter it.

The number will appear on the bottom line of the LCD as you enter it.

**To Dial a Speed Dial Number:**

1. Press the **Mode** button when telephone is idle.
2. Dial **8 NN** (**NN = 10 ~ 49** or **60 ~ 69**).

The LCD displays "MODE NO.?"

The speed dial number appears with name or memo. Personal speed dial code numbers are 10 ~ 49, and system numbers, stored from station 10 only, are 60 ~ 99.

**STRATA DK DIGITAL LCD TELEPHONE**

**MESSAGES AND MEMOS**

3. Press the **Page** button to scan the directory for the appropriate number/memo.
4. Press any available **CO** button.
5. The number is dialed.

**To Check a Speed Dial Number:**

1. Press **Mode 8** when telephone is idle.
2. Dial a 2-digit speed dial number.
3. Press the **Page** button to scan the directory for the appropriate number/memo.

Personal speed dial number (10 ~ 49) or system number (60 ~ 99).

If the number is longer than 16 digits, a "+" will appear in the far right corner of the display. Press the **Scroll** button to display the remaining digits.

**TIMED REMINDERS WITH MEMO**

This feature allows five separate messages (memos) to be set at each LCD station. These messages will be displayed at the times (hour and minute) set by the station user. They can either be displayed just once or repeated on a daily basis.

**To Set a Timed Reminder with Memo:**

1. Press the **Intercom** button.
2. Dial a 3-digit reminder number (**605 ~ 609**).
3. Enter the desired time for the message to be displayed.
4. Dial **0** if the message is to be repeated every day, or **1** if it is a one-time message only.

The 3-digit reminder number may be 605 ~ 609.

The message time must be in 24-hour clock format (i.e., HHMM).

**STRATA DK DIGITAL LCD TELEPHONE**

**MESSAGES AND MEMOS**

5. If desired, enter a message number.
6. Press the **Redial** button to record the data in memory.

Personal message (10 ~ 19) and system (60 ~ 99). The message does not display when setting a timed reminder—it displays when the reminder activates. Messages are set using the Record a Message method.

The LCD displays "DATA PROGRAMED". You will hear a confirmation tone. The message will be displayed at the specified time, and a beeping tone will be heard for 30 seconds (or until it is canceled by pressing the **Mode** button and then dialing 0 or lifting your handset).

**MESSAGE SENDING**

The Alphanumeric Messaging feature on your LCD digital telephone enables you to set short text (up to 32 characters) at your station to ensure that you do not miss important calls. Any station may record a message; however, only stations with the LCD are able to display messages. Stations that do not use Soft Keys (Soft Keys Off: Mode 7 0) may send messages "live" to other LCD station users. To record messages, see the Recording a Message section in this guide.

Your system has up to 40 preprogrammed messages that may be sent to other LCD digital or electronic telephones. You can temporarily add to or change any of these messages, in order to leave a personalized message at your station.

All stations may record and save up to 10 personal messages to be used for all types of station messaging. This is a station option that is enabled in system programming.

**CALLED STATION MESSAGING**

Your station number and a message indication may be sent to another LCD station. When that station responds, it will receive the message.

**IMPORTANT NOTE!**

*Soft Keys must be off (MODE 70) at the sending station for this feature to operate.*

**To Set a Called Station Message:**

1. Dial the station number (station rings but does not answer or is busy).

**STRATA DK DIGITAL LCD TELEPHONE**

**MESSAGES AND MEMOS**

2. Press the **Mode** button.
3. Dial **4**.
4. Enter the desired message number.
5. Press the **Msg** button.
6. Press the **Spkr** button to release.

The LCD displays "MODE?"

The LCD displays "MW TO STNN MSG NO?"

Personal message (10 ~ 19), system message (60 ~ 99). The LCD displays the message.

"CALL NNM" is displayed at the called station and the Msg LED flashes; "SENT NNM" is displayed at your station. NN = Station Number, M indicates that a message has been sent.

**To Receive a Called Station Message:**

Press the **Intercom** and **Msg** buttons.

Press these buttons when your telephone Msg LED is flashing; the message will display on your station.

**GROUP CALLED STATION MESSAGING**

This feature allows a station to set a Called Station Message for a group of stations.

**To Set a "Called Station" Message for Other Stations:**

1. Press the **Mode** button when your telephone is idle.
2. Dial **9 4**.
3. Dial the "destination" station's number.
4. Press the **Page** button.
5. Dial the "originating" station's number.
6. Press the **Page** button.
7. Enter the desired message's number.
8. Press the **Page** button.

The LCD displays "MODE?"

The LCD displays "MODE 94 DEST EKT NO.?"

The LCD displays "MODE 94 DEST EKT NO.NN". Enter 30 for the All Call station group, or 31 ~ 34 for page groups.

The LCD displays "MODE 94 ORG EKT NO.?"

Your number or another station number. The LCD displays "MODE 94 ORG EKT NO.NN".

The LCD displays "MSG NO.?"

The LCD displays the message.

The LCD displays "MSG NO.?"

**STRATA DK DIGITAL LCD TELEPHONE**

**MESSAGES AND MEMOS**

- 9. Press the **Mode** button. The LCD displays "MODE NO.?"
- 10. Dial **0**. The LCD displays date/day/time. The LCD then displays "SENT NNM" at originating station, and the originating station number and a message indication are displayed on the destination station LCD.

**To Receive a Called Station Message:**

- 1. Press the **Intercom** and **Msg** button. The message will display on the destination station LCD.

**REMOTE CALLING STATION MESSAGING**

**To Set a Calling Station Message for Another Station:**

- 1. Press the **Mode** button when your telephone is idle. The LCD displays "MODE?"
  - 2. Dial **9 5**. The LCD displays "MODE 95 DEST EKT NO.?"
  - 3. Dial the "destination" station number. The LCD displays "MODE 95 DEST EKT NO.NN".
  - 4. Press the **Page** button. The LCD displays "MSG NO.?"
  - 5. Enter the desired message number. The LCD displays the message.
  - 6. Press the **Page** button. The LCD displays "MSG NO.?"
- NOTE:  
Remote calling station messaging allows you to set a calling station message for only one station at a time.*
- 7. Press the **Mode** button. The LCD displays "MODE NO.?"
  - 8. Dial **0**. Your LCD shows the time and date. The message is displayed at the "destination" station. Any station calling the "destination" station receives the message.

**BUSY STATION MESSAGING**

When reaching a busy or DND LCD station, a message can be sent to that station (an audible tone will be heard). The busy or DND station may also return a message to the calling station's LCD. The two stations may continue this procedure to carry on a "silent" conversation.

**STRATA DK DIGITAL LCD TELEPHONE**

**MESSAGES AND MEMOS**

**IMPORTANT NOTE!**

*Soft Keys must be off (MODE 70) at the sending and receiving stations for this feature to operate.*

**To Send a Message to a Busy or DND Station:**

- 1. Call the desired station. Listen for a busy tone.
- 2. Press the **Mode** button. The LCD displays "MODE NO.?"
- 3. Dial **2**. The LCD displays "OVER TO STNN MSG NO?"
- 4. Enter the desired message number. Personal message (10 ~ 19) and system message (60 ~ 99). The LCD displays the message.
- 5. Press the **Page** button. The LCD displays "MSG SEND". The destination station beeps four times and the message is displayed for 30 seconds, or until the originating station hangs up.

**To Return a Message (within 30 Seconds) from the Busy Station After Receiving a "Busy Station" Message:**

- 1. Press the **Mode** button. The LCD displays "MODE NO?"
- 2. Dial **2**. The LCD displays "OVER TO STNN MSG NO?"
- 3. Enter the desired message number. Personal message (10 ~ 19) and system message (60 ~ 99). The LCD displays the message.
- 4. Press the **Page** button. The LCD displays "MSG SEND".

**TOSHIBA**

**S Y S T E M  
ADMINISTRATOR'S  
G U I D E**

**B U S I N E S S  
T E L E P H O N E S  
S O L U T I O N S**



**STRATA<sup>TM</sup> DK**

**D I G I T A L K E Y  
T E L E P H O N E S Y S T E M S  
STRATA DK8 & DK16**

## Table of Contents

**STRATA DK SYSTEM ADMINISTRATOR'S GUIDE**

**TABLE OF CONTENTS**

	SUBJECT	PAGE
<b>INTRODUCTION</b>		
	General Description .....	iii
	Purpose .....	iii
	Organization .....	iii
	Reference Documents .....	iv
	How to Use This Guide .....	iv
<b>CHAPTER 1</b>		
	<b>SETTING SYSTEM PARAMETERS</b> .....	1-1
	Changing Codes .....	1-1
	Direct Inward System Access (DISA) Codes .....	1-1
	Toll Restriction Override/Traveling Class Codes .....	1-2
	Verified Account Codes .....	1-3
	Date/Time/Day Adjustment .....	1-5
	User Name/Number Display .....	1-6
	System Speed Dial Numbers .....	1-9
	Programmable Feature Buttons .....	1-10
	Speed Dial Memo .....	1-11
<b>CHAPTER 2</b>		
	<b>STATION RELOCATION</b> .....	2-1
	Automatic Relocation .....	2-1
	Relocation by Special Dial .....	2-2
<b>APPENDIX</b>		
	User Name/Number Directory .....	A-1
	Speed Dial Memo Directory .....	A-2
	Feature Access Code List .....	A-3
<b>FIGURE LIST</b>		
FIGURE	SUBJECT	PAGE
I-1	Sample Page .....	v
1-1	Dialpad Information .....	1-8

*This page left blank intentionally.*

## Introduction

### GENERAL DESCRIPTION

This System Administrator's Guide contains information and procedures that are not available to the average telephone user. These procedures are meant to be performed by the System Administrator or by someone designated to have access to a designated System Administrator's phone. The System Administrator has the responsibility of using certain proprietary codes for providing or restricting features to telephones within the Strata DK8 and DK16 systems. *This document is not intended for general use and should be kept in a secure place.*

---

### PURPOSE

This document is designed for the telephone system administrator of the STRATA DK8 and DK16 systems. The telephone system administrator is generally the individual responsible for assigning the user names that appear on the station display, managing station relocation, assigning direct inward system access (DISA) security codes, toll restriction override access codes, and verified account codes.

### EQUIPMENT NOTES

1. Most of the operations in this guide require a Liquid Crystal Display (LCD) digital telephone at the System Administrator's position for information display.
2. Typically, station 10 is used to perform the functions in this guide. However, a different digital station may have been assigned by the system installer.

---

### ORGANIZATION

This administrator's guide is divided into three chapters. The Introduction consists of a general description of the digital telephones as well as the purpose and organization of this document. Suggestions on how to use this guide also appear in this section.

Chapter 1, "Setting System Parameters," contains descriptions and procedures for Changing Codes, Date/Time/Day Adjustment, Speed Dial and Button Programming.

Chapter 2, "Station Relocation" describes how to reassign a station's features to another location through Automatic Relocation (which generally involves physically moving a telephone to its new location, or through Special Dial Relocation, which allows you to reassign telephone features through programming.

The Appendix contains several directories for recording Speed Dial Memo Numbers, User Names/Numbers, and Telephone Locations.

REFERENCE DOCUMENTS

Other Strata DK8 and DK16 documentation which may be helpful is listed below: *General Description*, *Digital Telephone User Guide*, *Digital LCD Telephone User Guide*, *Standard Telephone User Guide*, *Add-On Module/DSS Console User Guide*, and *Data Interface User Guide*. Both the *Electrical Telephone User Guide* and the *Electrical LCD Telephone User Guide* are for DK16 only.

HOW TO USE THIS GUIDE

Most of the features in this guide are available with your telephone. The information in this guide is divided into distinct areas of content. Instructions for various procedures are referred to as Action Text and appear in the left-hand column of the page. Instructions appear in numerical sequence, enabling you to quickly perform a specific task. More detailed descriptions of these procedures, or explanations of their effects, are located in the right-hand column. Figure I-1 shows you the structure followed for each feature operation.

ACTION TEXT  
SPECIFIC INSTRUCTIONS ON HOW TO PERFORM A  
PROCEDURE ARE NUMBERED AND ENTERED IN  
THE LEFT-HAND COLUMN.

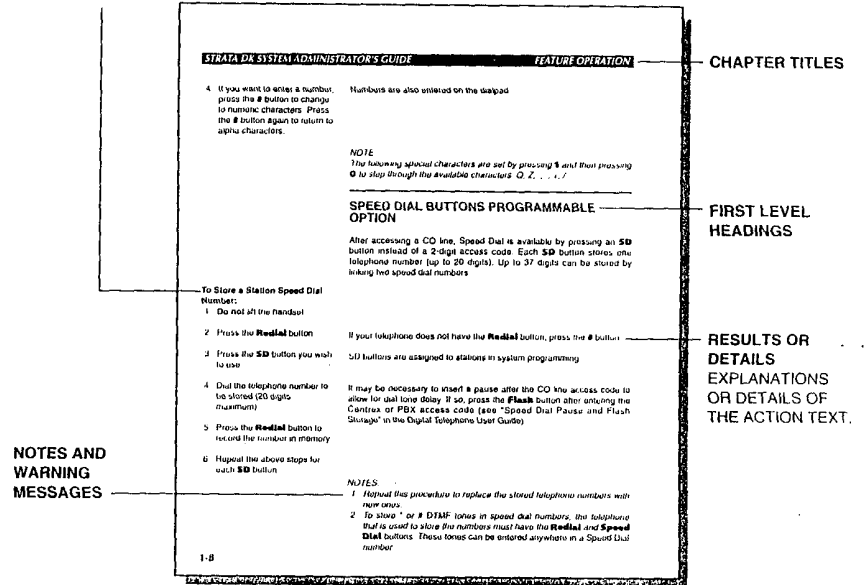


Figure I-1  
Sample Page

# Chapter 1

## CHANGING CODES

For security reasons, some codes can be added, deleted, or changed **only by the administrator**. The system administrator's telephone must be enabled in system programming to change each of the following codes. The following codes fall under the above mentioned category:

- Direct Inward System Access (DISA) Codes
- Toll Restriction Override/Traveling Class Codes
- Verified Account Codes

### IMPORTANT NOTE!

*The Liquid Crystal Display (LCD) examples in this guide are shown with soft keys turned OFF. If your telephone has soft keys turned ON, the displays may be different, but they will still allow you to follow the steps in this guide. Generally, the information shown on line 2 will display on line 1.*

### DIRECT INWARD SYSTEM ACCESS (DISA) CODES

The Direct Inward System Access feature is used when calling into your system from the outside. This feature is available on certain CO lines or designated stations, and is assigned by the system programmer. CO lines can be DISA lines in the Day, Day 2, or Night mode, or any combination of these modes.

#### To Enter or Change the DISA Security Code:

1. Press the **Intercom** button and dial **6 5 8**.
  
2. Dial the new DISA security code (1 - 15 digits).
  
3. Press the **Redial** button. If your telephone does not have the **Redial** button, press the **#** button.

You will hear a confirmation tone.

```

NO. NN
CODE ID CODE SET
    
```

The DISA security code digit length is a system program option. The code will appear on the LCD as you enter it.

You will hear a confirmation tone.

```

NO. NN
DATA PROGRAMMED
    
```

**STRATA DK SYSTEM ADMINISTRATOR'S GUIDE**

**SETTING SYSTEM PARAMETERS**

4. Press the **Spkr** button.

The telephone will return to the idle mode after you press the button.

**To Cancel the DISA Security Code:**

1. Press the **Intercom** button and dial **6 5 8**.
2. Press the **Redial** button. If your telephone does not have the **Redial** button, press the **#** button.
3. Press the **Spkr** button.

You will hear a confirmation tone.

You will hear a confirmation tone.

If the DISA code is canceled, outgoing access of CO lines on DISA calls will not require a security code.

The telephone will return to the idle mode after you press the button.

**TOLL RESTRICTION OVERRIDE/TRAVELING CLASS CODES**

Toll restriction at a station can be completely overridden, or the station's normal class can be changed to another class (Traveling Class).

**To Add/ Change Toll Restriction Override or Traveling Class Codes:**

1. Press the **Intercom** button and dial the assigned 3-digit Toll Restriction Override change access code.

You will hear a confirmation tone.



The 3-digit access codes are as follows:

- For Traveling Class 1, dial **6 2 2**.
- For Traveling Class 2, dial **6 2 3**.
- For Traveling Class 3, dial **6 2 4**.
- For Traveling Class 4, dial **6 2 5**.
- For "Override All" Code 1, dial **6 5 4**.
- For "Override All" Code 2, dial **6 5 5**.

2. Dial a desired 4-digit override code.

The code will appear on the LCD as you enter it.

3. Press the **Redial** button to store the code. If your telephone does not have the **Redial** button, press the **#** button.

You will hear a confirmation tone.



**STRATA DK SYSTEM ADMINISTRATOR'S GUIDE**

**SETTING SYSTEM PARAMETERS**

4. Press the **Spkr** button.

The telephone will return to the idle mode after you press the button.

5. Repeat steps 1 ~ 3 to enter up to four Traveling Class codes and two Toll Restriction Override codes.

**NOTE:**

The LCD responses shown in this procedure are the ones that are displayed when the Soft Key feature is deactivated.

**To Delete Toll Restriction Override or Traveling Class Code:**

1. Press the **Intercom** button and dial the assigned 3-digit Toll Restriction Override change access code.
2. Press the **Redial** button.
3. Press the **Spkr** button.

You will hear a confirmation tone.

You will hear confirmation tone.

The telephone will return to the idle mode after you press the button.

**VERIFIED ACCOUNT CODES**

Adding, deleting, or changing Verified Account Codes can be done at designated stations only. The privileged stations are assigned by the system programmer.

**To Add or Change Verified Account Codes:**

1. Press the **Intercom** button and dial the access code **6 5 9**.
2. Dial the desired 3-digit verified account code number (000 - 099 for DK8, 000 - 299 for DK16).

You will hear a confirmation tone.



The system memory can store a total of 100 account code numbers for DK8, and 300 for DK16. They are sequentially numbered from 000 through 099 for DK8, 000 through 299 for DK16. The account code number will appear on the LCD as you enter it. As you enter the account code, the words "VERIFY ACC SET" scroll to the left as the numbers appear on the display.



3. Dial the verified account code (4 ~ 15 digits).

```

NO. NN
RIFY ACC SET □□□
    
```

The account code digit length is assigned in the system programming. Each can be 4 ~ 15 digits long. The code will appear on the LCD as you enter it.

4. Press the **Redial** button to store the code. If your telephone does not have a **Redial** button, press the # button to store the code.

```

NO. NN
□□□□□□□□□□ . . . □□□
    
```

You will hear a confirmation tone.

5. Press the **Spkr** button.
6. Repeat steps 1 ~ 4 to enter more verified account codes.

```

NO. NN
DATA PROGRAMMED
    
```

The telephone will return to the idle mode after you press the button.

**To Delete Verified Account Codes:**

1. Press the **Intercom** button and dial the access code **6 5 9**.
2. Dial the 3-digit verified account code number (000 ~ 099 for DK8, 000 ~ 299 for DK16) to be deleted.
3. Press the **Redial** button. If your telephone does not have a **Redial** button, press the # button.
4. Press the **Spkr** button.

*NOTE:*  
The LCD responses shown in this procedure are the ones that are displayed when the Soft Key feature is deactivated.

You will hear a confirmation tone.

You will hear a confirmation tone.

The telephone will return to the idle mode after you press the button.

**DATE/TIME/DAY ADJUSTMENT**

The Date/Time/Day Adjustment feature operation is possible from only one station, station 10.

**To Set Date:**

1. Place the handset on-hook.
2. Press the **Intercom** button and dial **6 5 1**.
3. Dial the date (YYMMDD).
4. Press the **Redial** button. If your telephone does not have a **Redial** button, press the # button.
5. Press the **Spkr** button.

Dial year/month/day in the format YYMMDD. Enter a leading 0 for any single-digit month or day.

You will hear a confirmation tone.

The telephone will return to the idle mode after you press the button.

**To Set Time:**

1. Place the handset on-hook.
2. Press the **Intercom** button and dial **6 5 2**.
3. Dial the time (HHMMSS).
4. Press the **Redial** button. If your telephone does not have a **Redial** button, press the # button.
5. Press the **Spkr** button.

Dial hour/minute/ second in the 24-hour clock format HHMMSS. Enter a leading 0 for any single digit entered.

You will hear a confirmation tone.

The telephone will return to the idle mode after you press the button.

**To Set Day of the Week:**

1. Place handset on-hook.
2. Press the **Intercom** button and dial **6 5 3**.

**STRATA DK SYSTEM ADMINISTRATOR'S GUIDE**

**SETTING SYSTEM PARAMETERS**

3. Enter the number which corresponds to the appropriate day of the week.

- 1 = Sunday
- 2 = Monday
- 3 = Tuesday
- 4 = Wednesday
- 5 = Thursday
- 6 = Friday
- 7 = Saturday

4. Press the **Redial** button. If your telephone does not have a **Redial** button, press the # button.

You will hear a confirmation tone.

5. Press the **Spkr** button.

The telephone will return to the idle mode after you press the button.

**USER NAME/NUMBER DISPLAY**

This feature allows you to store a name (such as your name, telephone number, location, etc.) in the system memory for each station or device. This name (e.g., LOBBY) will display on the station's LCD while it is idle, and it will appear at other stations' LCDs when they are called. The name will also appear on the LCD during direct intercom, forwarded, and hunted calls. However, on override or Off-hook Call Announce (OCA) calls, the LCD will not display the name.

Name display information for non-LCD telephones or voice mail/auto attendant devices may be stored from the administrator's digital station (station 10). When NAME/NUMBER is recorded for non-LCD telephones or other devices, their NAME/NUMBER is displayed on LCD telephones when called. The name of a called telephone displays on the calling telephone's LCD when the calling telephone is using soft keys displays.

**NOTE:**

*Before entering names for other users, the Soft Key feature must be turned off by pressing the **Mode** button and dialing **7 0** when your telephone is idle. After the names have been entered, turn the feature back on by pressing the **Mode** button and dialing **7 1** when your telephone is idle.*

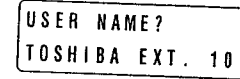
**STRATA DK SYSTEM ADMINISTRATOR'S GUIDE**

**SETTING SYSTEM PARAMETERS**

**To Enter Name/Number Information for Another Station/Voice Mail from Station 10:**

1. Press the **Intercom** button and dial **6 2 1**.

"USER NAME?" will appear on the upper line of the LCD. Current information for station 10 will appear on the lower line of the LCD.



Station NN may set and clear the NAME/NUMBER feature anytime:

- Set: **Intercom 6 2 1**.
- Clear: **Intercom 6 2 0**. "Clear" eliminates the display when calling, but does not erase it from memory; only station 10 can erase the NAME/NUMBER of a non-LCD station.

The LCD displays "DEST. EKT NO.?"

The LCD displays "DEST EKT NO. NN."

2. Press the **Page** button.

3. Dial the intercom number (**NN**) of the telephone or device for which NAME/NUMBER information will be recorded.

4. Press the **Page** button.

"USER NAME?" will appear on the upper line of the LCD. Current information for station NN will appear on the lower line of the LCD. The cursor will appear to the right of the last character of the current information.

5. Enter the new information via the dialpad.

Up to 16 characters can be recorded. See the following "Recording a NAME/NUMBER" procedure. It is recommended to record the station intercom number of the telephone along with the NAME.

6. Press the **Spkr** button.

The new information is stored and appears on the top line of station NN's LCD. Station 10's LCD returns to the normal idle display.

NOTES:

- To erase the NAME/NUMBER information of another station from station 10, repeat steps 1 ~ 6 above and enter blanks in step 5. Blanks are entered by pressing **1** in the alpha mode.
- If the system power is removed, the NAME/NUMBER information will not display when the system power is returned. To restore the NAME/NUMBER of another telephone or device after power interruption, repeat steps 1, 2, 3, 4, and 6, or dial **6 2 1** from that station.

Refer to Figure 1-1 for an explanation of the dialpad buttons.

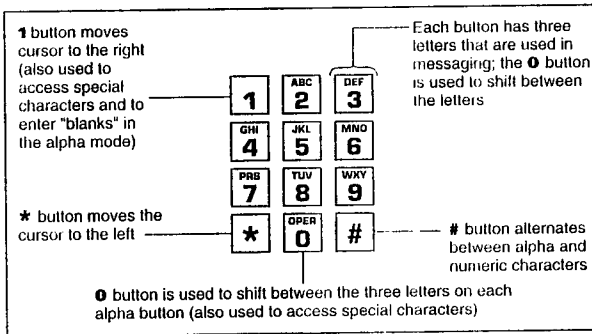


Figure 1-1  
Dialpad Information

To Record a NAME/NUMBER:

- Press the **#** button to access alpha characters.
- Move the cursor (-) to the desired position.
- Press the button that has the letter you want to enter.

For a new NAME move the cursor to the left edge of the display, or two spaces to the right of the preprogrammed NAME to add information.

- Use the **0** button to shift from letter to letter on the button. For example:
- If you press **3**, a D will be displayed. By pressing **0**, the D is changed to E. By pressing **0** again, the E is changed to F. Press **0** again and the F changes to D.
  - To enter a space, press **1**.

- If you want to enter a number, press the **#** button to change to numeric characters. Press the **#** button again to return to alpha characters.

Numbers are also entered on the dialpad.

NOTE:

When in the alpha character mode, the following special characters are set by pressing **1** and then pressing **0** to step through the available characters: **Q, Z, :, -, +, /**.

SYSTEM SPEED DIAL NUMBERS

System Speed Dial telephone numbers can be stored in the system memory by station 10 only.

To Store a System Speed Dial Number:

- Do not lift the handset.
- Press the **Redial** button and then the **Speed Dial** button.
- Dial a 2-digit System Speed Dial code.
- Dial the telephone number to be stored.
- Press the **Redial** button to record the telephone number in memory.
- Repeat steps 1 ~ 5 above for every telephone number to be stored.
- Write down the Speed Dial codes and telephone numbers for future reference.

If your telephone does not have the **Redial** button, press the **#** button. If your telephone does not have the **Speed Dial** button, press the **\*** button.

System Speed Dial codes run consecutively from 60 ~ 99.

A maximum of 20 digits can be stored.

A maximum of 40 (60 ~ 99) telephone numbers can be stored in the system memory.

**STRATA DK SYSTEM ADMINISTRATOR'S GUIDE**

**SETTING SYSTEM PARAMETERS**

**To Store Pauses and Flashes Along With Speed Dial Numbers:**

1. Press the **Spd Dial Pause** (or **Spd Dial Lng Pause**) button to store a pause.
2. Press the **Flash** button to store a flash.

**NOTE:**

Repeat steps 1 – 5 to replace the stored telephone numbers with new ones.

Pause timing is set by the telephone installer and can either be a 1/2 second, or 2 seconds/10 seconds long. Flashes referred to here are hookflashes.

If the **Spd Dial Pause** button is not available, the **Flash** button will store pauses only, not flashes.

The **Spd Dial Pause** button is used to program a 1/2-second or 2-second pause per system program assignment. A 10-second pause is programmed using the **Spd Dial Pause** button.

The telephone must have a **Spd Dial Pause** button and a Flash button to allow the Flash button to store Flashes.

**PROGRAMMABLE FEATURE BUTTONS**

In addition to station Speed Dial buttons for personal user programmable features, System Speed Dial buttons and codes can be assigned by the System Administrator. These Speed Dial buttons can store fixed button functions—**Conf/Trns**, **Intercom**, and **Hold**—enabling users to program feature buttons as Park and Page. A button can have just one feature or a sequence of features assigned to it. A maximum of 20 digits can be stored for each button. Fixed buttons count as two digits.

**To Store a Feature on a Button from the Administrator's Telephone (Station 10):**

1. Do **not** lift the handset.
2. Press the **Redial** button.
3. Press the **SD** button you wish to use.
4. Enter the desired code or sequence of codes (20 digits maximum).
5. Press the **Redial** button to record the code or codes in memory.

You have to exit this mode to make and answer a call. To exit the mode, press the **Redial** or **#** button.

Codes must be assigned to **SD** buttons associated with Speed Dial codes 60 – 99.

Refer to the Appendix for a list of feature access codes.

**STRATA DK SYSTEM ADMINISTRATOR'S GUIDE**

**SETTING SYSTEM PARAMETERS**

**To Store a Feature with a System Speed Dial Code:**

1. Do **not** lift the handset.
2. Press the **Redial** and **Speed Dial** buttons.
3. Dial a 2-digit System Speed Dial code (any of the codes 60 – 99).
4. Enter the desired code or sequence of codes (20 digits maximum).
5. Press the **Redial** button to record the code or codes in memory.
6. Write down the Speed Dial codes and associated assignments feature for future reference.

You have to exit this mode to make and answer a call. To exit the mode, press the **Redial** or **#** button.

If the Redial button does not appear on your telephone, use the **#** button. If the Speed Dial button does not appear on your telephone, use the **\*** button.

Refer to the Appendix for a list of feature access codes.

**SPEED DIAL MEMO**

This feature allows the administrator (usually station 10) to program a 12-character name for each of the 40 system Speed Dial numbers (60 – 99). The memo pad of names may be stepped through to select the appropriate party.

**NOTE:**

Before entering names for other users, the Soft Key feature must be turned off by pressing the **Mode** button and dialing **7 0** when the telephone is idle. After the names have been entered, turn the feature back on by pressing the **Mode** button and dialing **7 1** when the telephone is idle.

**Program Names and Numbers:**

Press the **Redial** button then the **Speed Dial** button.

The LCD will display "# \* NN SPEED DIAL". NN represents the entered Speed Dial number.

1. Dial the desired Speed Dial number.

If a name/memo is currently stored with its code, it will be displayed.

2. Press the **Mode** button.

The name/memo will appear on the LCD as you enter it.

3. Enter the name or memo.

See Figure 1-1, Dialpad Information.

4. Press the **Mode** button.

5. Enter the desired telephone number (20 digits maximum).

The number will appear on the LCD as you enter it. Speed Dial numbers and memos and their corresponding 2-digit codes may be recorded on the Speed Dial Memo Directory at the back of this guide.

7. Press the **Redial** button to record the data in memory.

8. Repeat steps 2 - 7 to enter more names/memos.

**To Dial a Speed Dial Number:**

1. Press the **Mode** button.

The LCD displays "MODE NO.?"

2. Dial **8** ( = **60 - 99**).

The Speed Dial number appears with a name or memo. Speed Dial numbers and memos and their corresponding 2-digit codes may be recorded on the Speed Dial Memo Directory at the back of this guide.

3. Press the **Page** button to scan the directory for the appropriate number/memo.

4. Press any available **Line** button.

5. The number will be dialed.

**To Check a Speed Dial Number:**

1. Press **Mode 8**.

2. Dial a 2-digit speed dial number (**60 - 99**).

3. If the number is longer than 16 digits, press the **Scroll** button to display the remaining digits.

4. To see the next number, press the **Page** button.

## Chapter 2

STRATA DK SYSTEM ADMINISTRATOR'S GUIDE

STATION RELOCATION

### STATION RELOCATION

The Station Relocation feature allows you to relocate an electronic, digital, or standard telephone without requiring reprogramming the station's features. When relocated, the telephone keeps its station number and all the features programmed in it, including personal messages, feature buttons and Speed Dial numbers.

One station at a time can be easily relocated. If two stations are unplugged at the same time, the telephone that was unplugged **last** will relocate. Station Relocation works only with the **same type** of station; for example, moving electronic telephone to electronic telephone, digital telephone to digital telephone, and standard telephone to standard telephone. If a 10-button telephone is replaced with a 20-button type, the left column of buttons will retain the 10 button assignments. With Liquid Crystal Display (LCD) telephones, you can look at the LCD of the calling or called intercom numbers, after relocation, to confirm the desired location.

#### CAUTION

**Always turn this feature OFF promptly after relocation is finished to avoid accidental relocation.**

#### AUTOMATIC RELOCATION

This function allows the System Administrator to physically move a telephone from one location to another location while maintaining all of the telephone's features. A "Telephone Location Record Sheet" is provided to at the back of this guide so that you can record telephone location information.

After you turn on Auto Station Relocation, you will hear a confirmation tone which indicates that the Station Relocation Feature is on. If you hear a busy tone instead of confirmation tone after dialing **6 2 8 2**, it's for one of two reasons: (1) Station Relocation was already turned on; or, you did not dial from station 10.

#### IMPORTANT NOTE:

*If relocating a telephone (Station A) to a location (Location 2) that already has a telephone (Station B), first disconnect Station B from its telephone jack before you disconnect Station A. In other words, you must make the location that you're moving to "vacant" before you unplug the phone that is being moved.*

#### To Automatically Relocate a Station:

1. From station 10, press the **Intercom** button and dial **6 2 8 2** to turn on the Auto Station Relocation feature, then press the **Spkr** button.
2. Make sure that the phone jack that the phone is moving to (Location 2) is already vacant. See "IMPORTANT NOTE" before proceeding to step 3.

3. Unplug Station A's modular cord from the wall jack of Location 1.
4. Plug in Station A's modular cord to the wall jack of its new location (Location 2).
5. If there is a second station (Station B) that you want to relocate, then plug in Station B to Location 1.
6. From station 10, press the **Intercom** button and dial **6 2 8 1** to turn off Auto Station Relocation, then press the **Spkr** button.

Station A is now relocated to its new location while retaining its original features.

After you turn off Auto Station Relocation, you will hear confirmation tone. If you hear a busy tone instead of confirmation tone after dialing **6 2 8 1**, it's for one of two reasons: (1) Station Relocation was already turned off; or, you did not dial from logical port 00 (usually station 10.)

**RELOCATION BY SPECIAL DIAL**

This feature allows two station numbers and the features programmed in them to be exchanged with or without physically relocating the telephones. The exchange takes place through the use of special dial codes.

**To Relocate by Special Dial:**

1. From station 10, press the **Intercom** button and dial **6 2 8 3** to turn on the Special Dial Station Relocation feature, then press **Spkr**.
2. Prepare Station A (in location 1) for relocation by pressing the **Intercom** button and dialing **6 2 6** from Station A.
3. Relocate Station A to Location 2 and Station B (if connected) to Location 1 by pressing the **Intercom** button and dialing **6 2 7** from the Station in Location 2.

After you turn on Relocation by Special Dial, you will hear confirmation tone which indicates that the Station Relocation Feature is on. If you hear a busy tone instead of confirmation tone after dialing **6 2 8 3**, it's for one of two reasons: (1) Station Relocation was already turned on; or, you did not dial from station 10.

You will hear confirmation tone.

After pressing **Intercom 6 2 7**, Station A will operate in location 2, with the same features that it had in location 1, and Station B will operate in Location 1 as it did in Location 2.

4. From Station 10, press the **Intercom** button and dial **6 2 8 1** to turn off Special Dial Station Relocation, then press the **Spkr** button.

After Station Relocation is turned off, you will hear confirmation tone. If you hear a busy tone instead of confirmation tone after dialing **6 2 8 1**, it's for one of two reasons: (1) Station Relocation was already turned off; or, you did not dial from station 10.

**NOTE:**

*After completion, the keystrips of the two telephones should be exchanged if they are different from each other. If a 10-button telephone is replaced with a 20-button type, the left column of buttons will retain the 10 button assignments; therefore, the telephones should be physically exchanged instead of just the keystrips.*

After you turn off Auto Station Relocation, you will hear confirmation tone. If you hear a busy tone instead of confirmation tone after dialing **6 2 8 1**, it's for one of two reasons: (1) Station Relocation was already turned off; or, you did not dial from Station 10.

# Appendix

## USER NAME/NUMBER DIRECTORY

NAME/NUMBERS are limited to 16 alphanumeric characters and are displayed on the top row of idle LCD stations and the bottom row of called LCD stations.

This directory is provided for station 10, the administrator's station, reference and recording of other station NAME/NUMBERS.

Station # \_\_\_\_\_

D	A	T	E	D	A	Y	T	I	M	E					

Station # \_\_\_\_\_

D	A	T	E	D	A	Y	T	I	M	E					

Station # \_\_\_\_\_

D	A	T	E	D	A	Y	T	I	M	E					

Station # \_\_\_\_\_

D	A	T	E	D	A	Y	T	I	M	E					

Station # \_\_\_\_\_

D	A	T	E	D	A	Y	T	I	M	E					

Station # \_\_\_\_\_

D	A	T	E	D	A	Y	T	I	M	E					



