

**INSTALLER / CONSUMER
SAFETY INFORMATION**

**PLEASE READ THIS MANUAL
BEFORE INSTALLING AND
USING APPLIANCE**

WARNING!

**IF THE INFORMATION IN THIS
MANUAL IS NOT FOLLOWED
EXACTLY, A FIRE OR EXPLO-
SION MAY RESULT CAUSING
PROPERTY DAMAGE, PERSON-
AL INJURY OR LOSS OF LIFE.**

FOR YOUR SAFETY

**Installation and service must
be performed by a qualified
installer, service agency or the
gas supplier.**

WHAT TO DO IF YOU SMELL GAS:

- Do not try to light any appliance.
- Do not touch any electric switch; do not use any phone in your building.
- Immediately call your gas supplier from your neighbor's phone. Follow the gas suppliers instructions.
- If you cannot reach your gas supplier call the fire department.

**DO NOT STORE OR USE GASO-
LINE OR OTHER FLAMMABLE
VAPORS AND LIQUIDS IN THE
VICINITY OF THIS OR ANY OTH-
ER APPLIANCE.**

**WARNING: Improper installation, ad-
justment, alteration, service or main-
tenance can cause injury or property
damage. Refer to this manual. For
assistance or additional information,
consult a qualified installer, service
agency or the gas supplier.**

U.S. Patents: 5,669,374; 5,562,088; 6,138,667;
Can. Patent: 2,139,684

TEMCO

FIREPLACE PRODUCTS

Direct Vent Zero Clearance Gas Fireplace Heater

Models:

DV1000N/P, DV1200N/P, DV1400N/P

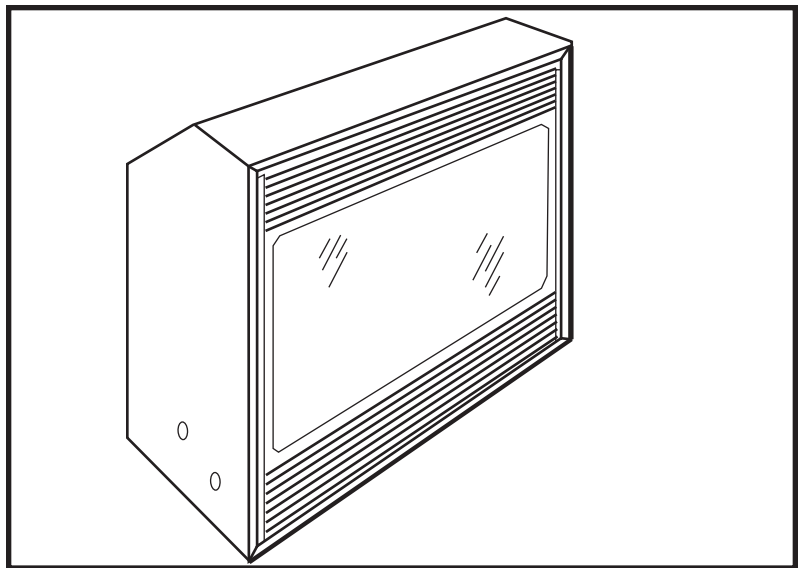

Homeowner's Installation and Operating Manual



C US

**INSTALLER: Leave this manual with the appliance.
CONSUMER: Retain this manual for future reference.**

Table of Contents

PLEASE READ THE INSTALLATION & OPERATING INSTRUCTIONS BEFORE USING APPLIANCE.

Thank you and congratulations on your purchase of a Temco Fireplace Products fireplace.

While we have written these instructions as accurately and thoroughly as possible, they may not cover every system, variation or contingency. Also, questions of interpretation may arise. For more information, solutions to particular problems or clarifications, contact your local distributor or the manufacturer. See the unit rating plate for whom to contact.

IMPORTANT: Read all instructions and warnings carefully before starting installation. Failure to follow these instructions may result in a possible fire hazard and will void the warranty.

Installation & Operating Instructions	
General Information, Warnings, Cautions	3
Requirements for the Commonwealth of Massachusetts	4
Fireplace Dimensions	4
Locating Your Fireplace	6
Framing & Finishing	6
Clearance to Combustibles	7
Combustible Sidewall Clearance	7
Mantels	7
Surround Material	7
Gas Specifications	8
Gas Inlet and Manifold Pressures	8
Gas Line Installation	8
General Venting Information	
General Venting	9
General Venting Information - Termination Location	10
Termination Clearances	11
Sidewall (General) Venting Information	12
Flex Venting	12
Sidewall (Horizontal) Venting	13
Flex Vent Offsets	13
Flex Vent Through the Roof (Vertical) Applications	15
VSK7 Vertical Flex Vent Kit Installation	15
TDV Series Direct Vent System Installation	16
Sidewall (Horizontal) Venting, General	16
Through the Roof (Vertical) Venting	17
Elbows & Offsets - General	17
Sidewall (Horizontal) Venting Information	17
Venting Components	20
Operating Instructions	
Glass Door Removal Procedure	24
Glass Cleaning	24
Louvre Installation	24
Log Installation	25
Thermostatic Fan Kit - Optional	26
Electrical Services	26
Speed Control Switch	26
Millivolt System	26
Burner ON/OFF	26
Managing Heat Output	27
Fan Operation	27
Flame Characteristics	27
Lighting & Operating Instructions	28
Troubleshooting	29
Maintenance	
Unit Adjustment	32
Maintenance	32
Replacement Parts	35
Servicing	35
Warranty	36
Installation and Startup Checklist	37
Warranty Registration	39

Installation & Operating Instructions

This gas appliance should be installed by a qualified installer in accordance with local building codes and with current **CSA-B149.1** Installation codes for Gas Burning Appliances and Equipment. For U.S.A Installations follow local codes and/or the current **National Fuel Gas Code, ANSI Z223.1/NFPA 54.**

FOR SAFE INSTALLATION AND OPERATION PLEASE NOTE THE FOLLOWING:

1. This fireplace gives off high temperatures and should be located out of high traffic areas and away from furniture and draperies.
2. Children and adults should be alerted to the hazards of the high surface temperatures of this fireplace and should stay away to avoid burns or ignition of clothing.
3. **CAUTION: Due to high glass surface temperature children should be carefully supervised when in the same room as fireplace.**



4. Under no circumstances should this fireplace be modified. Parts removed for servicing should be replaced prior to operating this fireplace again.
5. Installation and any repairs to this fireplace must be performed by a qualified installer, service agency or gas supplier. A professional service person should be contacted to inspect this fireplace annually. Make it a practice to have all of your gas fireplaces checked annually. More frequent cleaning may be required due to excess lint and dust from carpeting, bedding material, etc.
6. Control compartments, burners and air passages in this fireplace should be kept clean and free of dust and lint. Make sure the gas valve and pilot light are turned off before you attempt to clean this fireplace.
7. The venting system (chimney) of this fireplace should be checked at least once a year and if needed your venting system should be cleaned.
8. Keep the area around your fireplace clear of combustible materials, gasoline and other flammable vapor and liquids. This fireplace should not be used as a drying rack for clothing, nor should Christmas stocking or decorations be hung in the area of it.
9. Under no circumstances should any solid fuels (wood, coal, paper or cardboard etc.) be used in this fireplace.
10. For safe operation, the glass door must be closed.
11. Do not use this heater if any part has been under water. Immediately call a qualified service technician to inspect the heater and to replace any part of the control system and any gas control which has been under water.

12. Do not operate appliance unless completely installed as per installation instructions.
13. This appliance may be used in a bedroom installation. Install in accordance with local building codes and regulations.
14. Never use your fireplace as a cooking device.

DV1000 / DV1200 / DV1400

Certified To

ANSI Z21.88-2005 / CSA 2.33-2005 / UL 307B

Vented Gas Fireplace Heater

WARNING: Check with your electronics manufacturer before installing a television or other electronic device above this fireplace.

This appliance may be installed in an aftermarket permanently located, manufactured home or mobile home, where not prohibited by local codes.

This appliance is only for use with the type of gas indicated on the rating plate. This appliance is not convertible for use with other gases, unless a certified kit is used.

IMPORTANT:

PLEASE READ THE FOLLOWING CAREFULLY

Remove any plastic from trim parts before turning the fireplace ON.

It is normal for fireplaces fabricated of steel to give off some expansion and/or contraction noises during the start up or cool down cycle. Similar noises are found with your furnace heat exchanger or car engine. It is not unusual for your gas fireplace to give off some odor the first time it is burned. This is due to the manufacturing process.

Please ensure that your room is well ventilated -open all windows.

It is recommended that you burn your fireplace for at least four (4) hours the first time you use it. If the optional fan kit has been installed, place the fan switch in the "OFF" position during this time.

The embers supplied with your fireplace are made from a high grade rock wool and should be handled carefully. Wash your hands immediately after touching to avoid irritation. The embers must be placed correctly in order to function properly.

WARNING: When purging the gas line, the glass front must be removed.

Installation & Operating Instructions

Requirements for the Commonwealth of Massachusetts

All gas fitting and installation of this heater shall only be done by a licensed gas fitter or licensed plumber.

For all side wall horizontally vented gas fueled equipment installed in every dwelling, building or structure used in whole or in part for residential purposes, including those owned or operated by the Commonwealth and where the side wall exhaust vent termination is less than seven (7) feet above finished grade in the area of the venting, including but not limited to decks and porches, the following requirements shall be satisfied:

Installation of Carbon Monoxide Detectors

At the time of installation of the side wall horizontal vented gas fueled equipment, the installing plumber or gas fitter shall observe that a hard wired carbon monoxide detector with an alarm is installed on each additional level of the dwelling, building or structure served by the side wall horizontally vented gas fueled equipment. It shall be the responsibility of the property owner to secure the services of qualified licensed professionals for the installation of hard wired carbon monoxide detectors.

In the event that the side wall horizontally vented gas fueled equipment is installed in a crawl space or an attic, the hard wired carbon monoxide detector with alarm and battery back-up may be installed on the next adjacent floor level.

In the event that the requirements of this subdivision can not be met at the time of completion of installation, the owner shall have a period of thirty (30) days to comply with the above requirements; provided, however, that during said thirty (30) day period, a battery operated carbon monoxide detector with an alarm shall be installed.

Approved Carbon Monoxide Detectors

Each carbon monoxide detector as required in accordance with the above provisions shall comply with NFPA 720 and ANSI/UL 2034 listed and IAS certified.

Signage

A metal or plastic identification plate shall be permanently mounted to the exterior of the building at a minimum height of eight (8) feet above grade directly in line with the exhaust vent terminal for the horizontally vented gas fueled heating appliance or equipment. The sign shall read, in print size no less than one-half (1/2) inch in size, "**GAS VENT DIRECTLY BELOW, KEEP CLEAR OF ALL OBSTRUCTIONS**".

Inspection

The state or local gas inspector of the side wall horizontally vented gas fueled equipment shall not approve the installation unless, upon inspection, the inspector observes carbon monoxide detectors and signage installed in accordance with the provisions of 248 CMR 5.08(2)(a)1 through 4.

Exemptions

The following equipment is exempt from 248 CMR 5.08(2)(a)1 through 4:

- The equipment listed in Chapter 10 entitled "Equipment Not Required To Be Vented" in the most current edition of NFPA 54 as adopted by the Board; and
- Product Approved side wall horizontally vented gas fueled equipment installed in a room or structure separate from the dwelling, building or structure used in whole or in part for residential purposes.

MANUFACTURER REQUIREMENTS

Gas Equipment Venting System Provided

When the manufacturer of Product Approved side wall horizontally vented gas equipment provides a venting system design or venting system components with the equipment, the instructions provided by the manufacturer for installation of the equipment and the venting system shall include:

- Detailed instructions for the installation of the venting system design or the venting system components; and
- A complete parts list for the venting system design or venting system.

Gas Equipment Venting System NOT Provided

When the manufacturer of a Product Approved side wall horizontally vented gas fueled equipment does not provide the parts for venting the flue gases, but identifies "special venting systems", the following requirements shall be satisfied by the manufacturer:

- The referenced "special venting system" instructions shall be included with the appliance or equipment installation instructions; and
- The "special venting systems" shall be Product Approved by the Board, and the instructions for that system shall include a parts list and detailed installation instructions.

A copy of all installation instructions for all Product Approved side wall horizontally vented gas fueled equipment, all venting instructions, all parts lists for venting instructions, and/or all venting design instructions shall remain with the appliance or equipment at the completion of the installation.

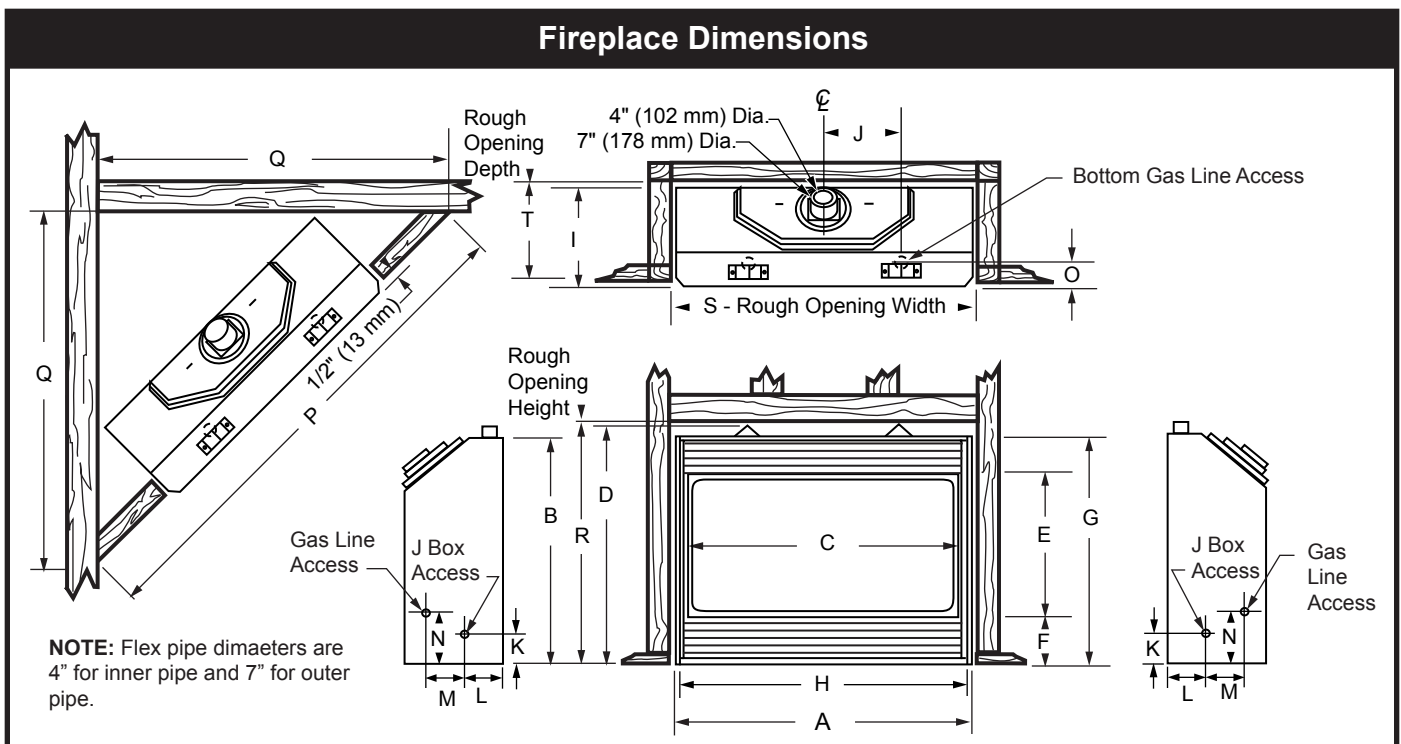

Fig. 1 Fireplace specifications and framing dimensions.

Ref.	DV1000	DV1200	DV1400
A	34 ¹ / ₄ " (870mm)	35 ¹³ / ₁₆ " (190mm)	41 ³ / ₄ " (1061mm)
B	28 ³ / ₈ " (721mm)	33" (838mm)	33" (838mm)
C	31 ¹ / ₈ " (791mm)	32 ⁹ / ₁₆ " (827mm)	38 ³ / ₄ " (984mm)
D	29 ⁷ / ₈ " (759mm)	34 ¹ / ₂ " (876mm)	34 ¹ / ₂ " (876mm)
E	16 ³ / ₄ " (426mm)	21 ³ / ₈ " (543mm)	21 ³ / ₈ " (543mm)
F	5 ³ / ₄ " (146mm)	6 ¹ / ₄ " (159mm)	6 ¹ / ₄ " (159mm)
G	27 ¹ / ₂ " (699mm)	32" (813mm)	32" (813mm)
H	32 ³ / ₄ " (832mm)	34 ¹ / ₄ " (870mm)	40 ¹ / ₄ " (1022mm)
I	13 ¹ / ₈ " (333mm)	14 ¹ / ₄ " (362mm)	14 ¹ / ₄ " (362mm)
J	13 ³ / ₈ " (340mm)	13 ³ / ₈ " (340mm)	13 ³ / ₈ " (340mm)
K	1 ⁵ / ₈ " (41mm)	1 ⁵ / ₈ " (41mm)	1 ⁵ / ₈ " (41mm)
L	5 ¹ / ₈ " (130mm)	5 ⁵ / ₈ " (143mm)	5 ⁵ / ₈ " (143mm)
M	3 ³ / ₄ " (95mm)	4 ¹ / ₂ " (114mm)	4 ¹ / ₂ " (114mm)
N	3 ³ / ₄ " (95mm)	4 ¹ / ₂ " (114mm)	4 ¹ / ₂ " (114mm)
O	3" (76mm)	3" (76mm)	3" (76mm)
Framing Dimensions			
P	63 ⁵ / ₃₂ " (1604mm)	64 ²⁹ / ₃₂ " (1633mm)	71 ¹ / ₁₆ " (1808mm)
Q	44 ¹¹ / ₁₆ " (1135mm)	45 ⁷ / ₈ " (1165mm)	50 ⁵ / ₁₆ " (1295mm)
R	30 ¹ / ₈ " (765mm)	34 ³ / ₄ " (883mm)	34 ³ / ₄ " (883mm)
S	34 ¹ / ₂ " (876mm)	36" (914mm)	42" (1067mm)
T	Refer to Figure 3 or 4 for Rough Opening Depth		

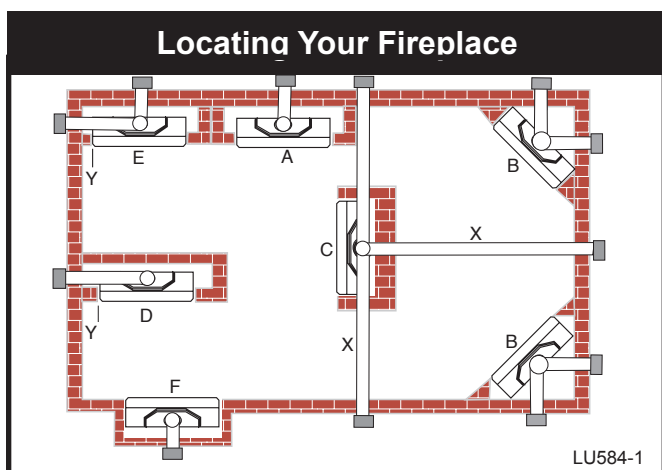
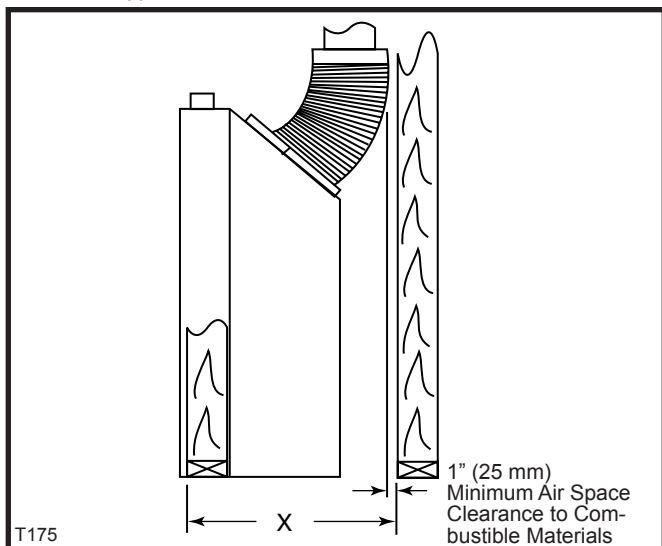

Fig. 2 Locate gas fireplace.
 A) Flat on wall B) Cross Corner C) As an Island
 D) As a room divider E) Flat on wall corner F) Exterior wall

Island installation is possible as long as the horizontal portion of the vent system does not exceed maximum recommended horizontal run as outlined in the venting chart on Page 10. When you install your fireplace as in position 'B', 'D' or 'E', (Fig. 2) a minimum of 1" (25mm) clearance must be maintained from the perpendicular wall and the front of the appliance.



Vent System Used	"X"		
	DV1000	DV1200	DV1400
TEMCO 4/7 Flex	17½" (445 mm)	18½" (470 mm)	19½" (495 mm)
TEMCO 4/7 Rigid	18½" (470 mm)	19½" (495 mm)	19½" (495 mm)
Duravent 4/6-5/8 GS	17½" (445 mm)	18½" (470 mm)	18½" (470 mm)

Fig. 3 Minimum framing depths with vertical takeoff.

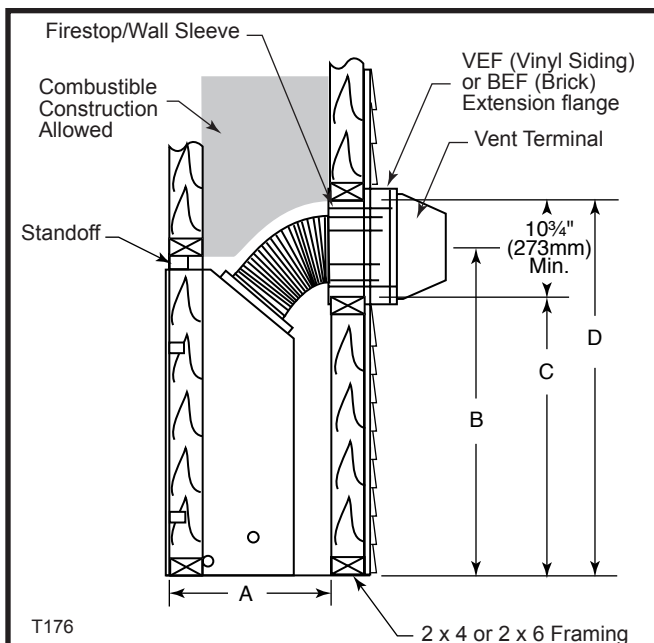

Model	A	B	C	D
DV1000	15¾" Min. (391mm)	30⅛" (765mm)	25⅜" (645mm)	36⅛" (918mm)
DV1200	16½" Min. (419mm)	34¾" (883mm)	30" (762mm)	40¾" (1035mm)
DV1400	16½" Min. (419mm)	40¾" (1035mm)	36" (914mm)	46¾" (1188mm)

Fig. 4 Minimum framing dimensions with horizontal venting.

Framing and Finishing

1. Choose a fireplace location and frame in accordance with the fireplace dimensions specified on Page 3 of this manual. When using a surround, the fireplace must be flush to the wall. Also, allowances must be made for drywall, tile or any other facing used around the unit.
2. When the appliance is installed directly on carpeting, tile or other combustible material other than wood flooring, the appliance shall be installed on a metal or wood platform.
3. Pull out the nail tabs which are located on each side of the fireplace. Move the fireplace into position and secure to the floor with screws or nails through the holes provided in the bottom flanges of the side casing. After checking unit for squareness, secure top of fireplace to the framing with screws or nails using the nailing tabs provided.
4. Cold climate installation recommendation: when installing this fireplace against a non-insulated exterior wall or chase, it is recommended that the outer walls be insulated to conform to applicable insulation codes. Drywall should be installed around the unit to prevent insulation from contacting the body.

Note: Never let vapor barrier contact the outer case of this fireplace or venting.

- Drywall can be extended flush on the bottom, top and to the outermost part of the sides of the fireplace.
- Noncombustible materials such as brick and tile can be extended across the face of the fireplace. If brass trim kit is going to be installed, brick and tile will have to be installed flush with the front of this appliance.

Clearance to Combustibles

Top of unit to ceiling*36" (914 mm)
 Front of unit to combustibles36" (914 mm)

Appliance

Top (from standoffs)0" (0mm)
 Bottom0" (0mm)
 Side (from standoffs).....0" (0mm)
 Back (from standoffs).....0" (0mm)
 Top of Elbow2" (51mm)

* Ceiling height is the minimum height of the room ceiling in front of the fireplace measured from the top front edge of the fireplace.

Combustible Sidewall Clearance

The perpendicular combustible sidewall or mantel support leg (surround) clearance is 1¾" (45mm) from the edge of the recessed door opening.

Mantels

The height that a combustible mantel is fitted above the fireplace is dependent on the depth of the mantel. For the correct mounting height and widths, refer to Figure 5.

Noncombustible mantels and legs may be installed at any height and width around the appliance. When using paint or lacquer, it must be heat resistant to prevent discoloration.

WARNING: Combustible objects must not be placed on a noncombustible mantel unless the noncombustible mantel meets the minimum height and width requirements for a combustible mantel.

Surround Material

When using materials around the face of the fireplace, these materials must be suitable to withstand the temperatures which they will encounter. Also these materials must not extend out in front of the face of the unit, in effect recessing the unit.

If the material used for surround is not flush with the face of the unit, then the optional surround kits will not fit properly.

It is recommended that any material used to surround the face of the fireplace be noncombustible (i.e. ceramic tile, brick, natural stone, etc.). Combustible materials such as drywall, are permissible.

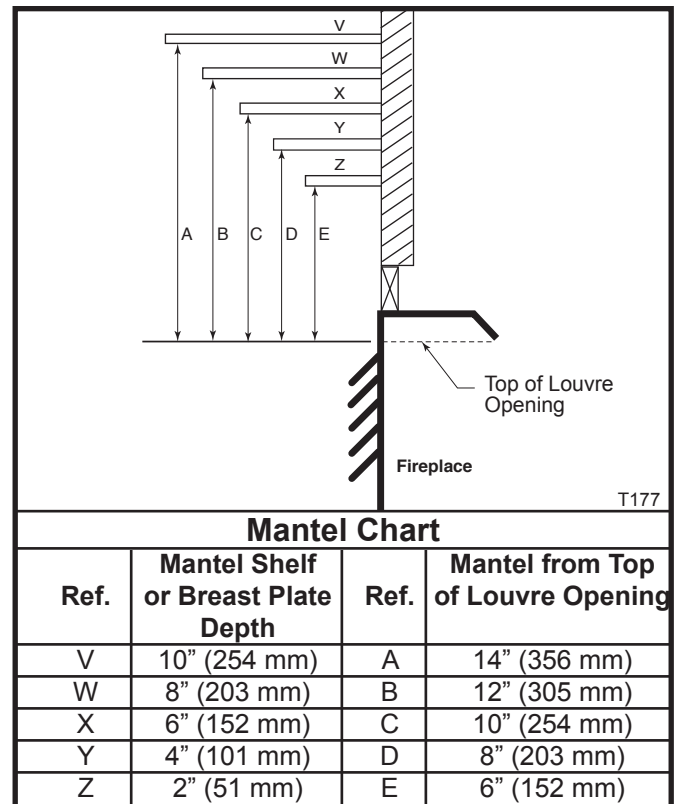

Fig. 5 combustible mantel minimum installation.

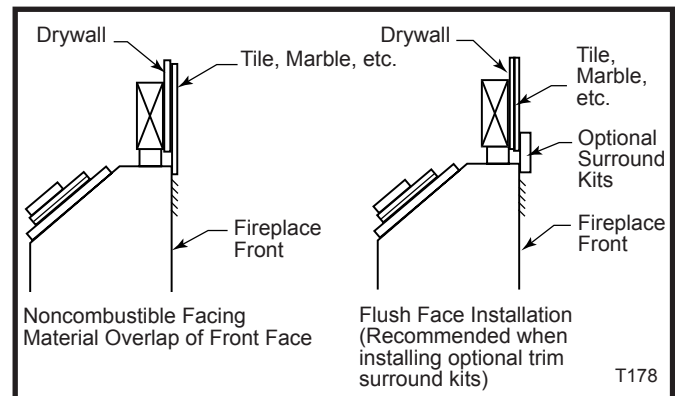

Fig. 6 Surround material options.

Materials such as cultured marble or other synthetic materials are not recommended as they may discolor, warp or create odor as a result of exposure to the temperatures of the front of the fireplace.

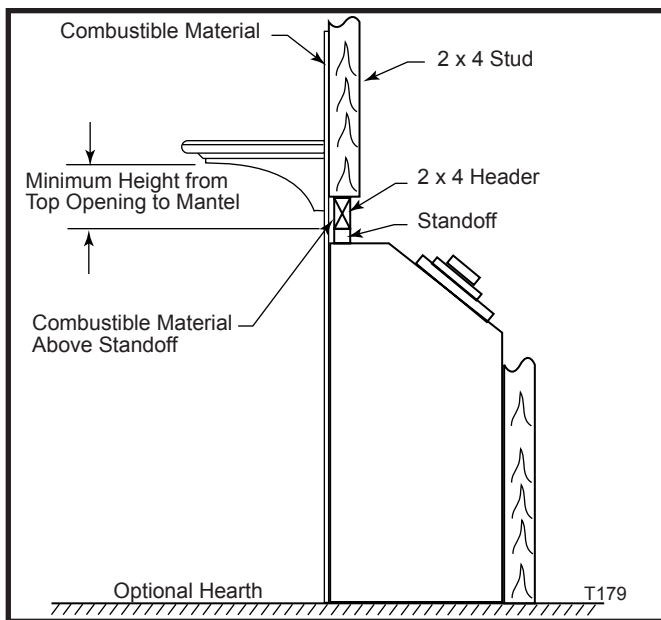

Fig. 7 Gas fireplace installation.

Gas Specifications				
Model	Fuel	Gas Control	Max. Input BTU/h	Min. Input BTU/h
DV1000N	Natural	Hi/Lo	18,500	12,500
DV1000P	Propane	Hi/Lo	18,500	12,500
DV1200N	Natural	Hi/Lo	20,000	13,000
DV1200P	Propane	Hi/Lo	20,000	13,000
DV1400N	Natural	Hi/Lo	22,000	15,000
DV1400P	Propane	Hi/Lo	22,000	15,000

Gas Inlet and Manifold Pressures		
	Natural	LP (Propane)
Minimum Inlet Pressure	4.5" w.c.	10.8" w.c.
Maximum Inlet Pressure	14.0" w.c.	14.0" w.c.
Manifold Pressure	3.5" w.c.	10.0" w.c.

Gas Line Installation

This gas appliance should be installed by a qualified installer in accordance with local building codes and with current CSA-B149.1 installation codes for Gas Burning Appliances and Equipment in Canada and the National Fuel Gas Code ANSI Z223.1/NFPA 54 in the U.S.A.*

1. The gas pipeline can be brought in through the bottom or the right or the left side of the appliance. A hole is provided at all locations to allow for the gas pipe installation and testing of any gas connection.
2. The gas control inlet is 3/8" NPT. Typical installation layout for rigid pipe is shown on Page 8.

NOTE: All models are equipped with a flex tube with a shut off valve having a 1/2" NPT inlet. The flex line with shut off is shipped in the control valve compartment. Using two wrenches,

tighten the flexible tube at the shut off valve and at the gas control.

3. When using a flex connector,* use only approved fittings. When a union is installed, provide easy access in it's placement for servicing. Refer to gas specification for pressure details and ratings.
4. When a vertical section of gas pipe is required for the installation, a condensation trap is needed. In Canada see CSA - B149.1 for code details. See the National Fuel Gas Code ANSI Z223.1/NFPA 54 in the USA.

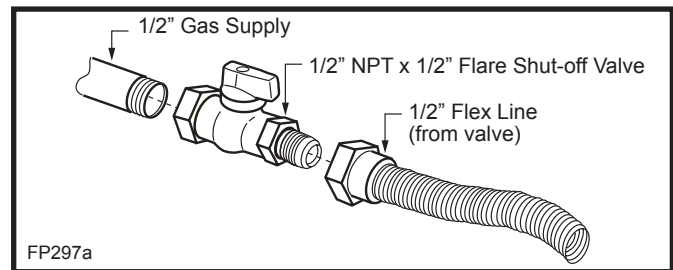

Fig. 8 Typical gas supply installation.

5. For natural gas, a minimum of 3/8" iron pipe with a gas supply pressure of 4.5" w.c. (from the gas meter). Consult with local gas utility and ANSI Z223.1/NFPA 54 if any questions arise concerning pipe sizes.
6. Turn the gas supply to 'ON' and check for leaks. **DO NOT USE OPEN FLAME FOR THIS PURPOSE.** Use an approved leak testing solution.
7. The appliance and its appliance main gas valve must be disconnected from the gas supply piping system during any pressure testing of that system at test pressures in excess of 1/2psig (3.5 KPa).
8. The appliance must be isolated from the gas supply piping system by closing its equipment shut off valve during any pressure testing of the gas supply piping system at test pressures equal to or less than 1/2psig (3.5KPa).

NOTE: The gas line connection may be made of 3/8" minimum rigid pipe, 3/8" minimum copper pipe or an approved flex connector. Since some municipalities have additional local codes, it is always best to consult your local authorities and the current CSA-B149.1 installation code in Canada or National Fuel Gas Code ANSI Z223.1/NFPA 54 in the U.S.A.

*Adhere to the following installation requirements in the State of Massachusetts:

- The installer must be a licensed plumber or gas fitter.
- Flex connectors must be Massachusetts approved, cannot exceed 36" (914 mm) in length, must be a minimum 1/2" dia., and may not penetrate a wall.

IMPORTANT: Always check for gas leaks with a soap and water solution. Do not use open flame for leak testing.

General Venting

When locating the vent termination, the minimum vent clearances must be observed. (Page 10, Fig. 9)

NOTE: Local codes may require different clearances.

It is recommended that the termination not be located within 24" (305mm) of garden sheds, fences, decks, utility buildings or other obstructions.

Do not locate termination cap where excessive snow or ice build up may occur. Be sure to check vent termination area after snow falls and clear to prevent accidental blockage of venting system. When using snow blowers, make sure snow is not directed towards vent termination area.

This appliance has a "special vent system". Check with local codes or in the absence of same, with CSA B149.1 installation codes in Canada, or the current National Fuel Gas Code ANSI Z223.1/NFPA 54 in the USA, regarding special vent termination clearances.

These fireplaces are certified for use with four types of venting systems

1. Temco 4" x 7" dia. flex vent.
2. Temco TDV series 4" x 7" dia. rigid vent.
3. Simpson Dura-Vent GS series 4" x 6⁵/₈" dia. vent.
4. Security Secure Vent series 4" x 6⁵/₈" dia. vent.

Review general venting information in this manual, and information packed with the venting prior to starting the installation of the fireplace.

- Termination shall not be recessed into a wall or siding.
- Horizontal sections must maintain a minimum 1/4" rise per linear foot of horizontal run.
- Combustible clearances from any horizontal vent pipe area must be 2" (51 mm) from top of vent, and 1" (25 mm) from sides and bottom.
- Clearance to combustibles from vertical pipe surface is 1" (25 mm).

General Venting Information - Termination Location

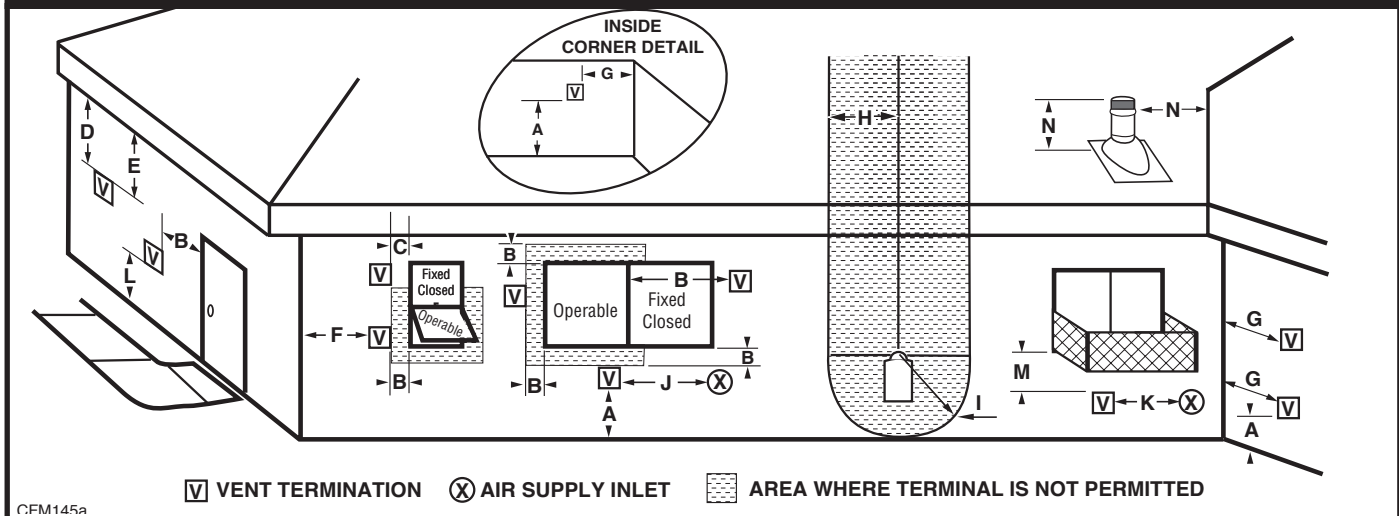

CFM145a

	Canadian Installations ¹	US Installations ²
A = Clearance above grade, veranda, porch, deck, or balcony	12" (30 cm)	12" (30 cm)
B = Clearance to window or door that may be opened	6" (15 cm) for appliances < 10,000 Btuh (3kW), 12" (30 cm) for appliances > 10,000 Btuh (3kW) and < 100,000 Btuh (30kW), 36" (91 cm) for appliances > 100,000 Btuh (30kW)	6" (15 cm) for appliances < 10,000 Btuh (3kW), 9" (23 cm) for appliances > 10,000 Btuh (3kW) and < 50,000 Btuh (15kW), 12" (30 cm) for appliances > 50,000 Btuh (15kW)
C = Clearance to permanently closed window	12" (305 mm) recommended to prevent window condensation	12" (305 mm) recommended to prevent window condensation
D = Vertical clearance to ventilated soffit located above the terminal within a horizontal distance of 2 feet (610mm) from the center line of the terminal	18" (458 mm)	18" (458 mm)
E = Clearance to unventilated soffit	12" (305 mm)	12" (305 mm)
F = Clearance to outside corner	see next page	see next page
G = Clearance to inside corner (see next page)	see next page	see next page
H = Clearance to each inside of center line extended above meter/regulator assembly	3' (91 cm) within a height of 15' above the meter/regulator assembly	3' (91 cm) within a height of 15' above the meter/regulator assy
I = Clearance to service regulator vent outlet	3' (91 cm)	3' (91 cm)
J = Clearance to nonmechanical air supply inlet to building or the combustion air inlet to any other appliances	6" (15 cm) for appliances < 10,000 Btuh (3kW), 12" (30 cm) for appliances > 10,000 Btuh (3kW) and < 100,000 Btuh (30kW), 36" (91 cm) for appliances > 100,000 Btuh (30kW)	6" (15 cm) for appliances < 10,000 Btuh (3kW), 9" (23 cm) for appliances > 10,000 Btuh (3kW) and < 50,000 Btuh (15kW), 12" (30 cm) for appliances > 50,000 Btuh (15kW)
K = Clearance to a mechanical air supply inlet	6' (1.83 m)	3' (91 cm) above if within 10' (3 m) horizontally
L = Clearance above paved sidewalk or paved driveway located on public property	7' (2.13 m)†	7' (2.13 m)†
M = Clearance under veranda, porch, deck or balcony	12" (30 cm)‡	12" (30 cm)‡
N = Clearance above a roof shall extend a minimum of 24" (610 mm) above the highest point when it passes through the roof surface, and any other obstruction within a horizontal distance of 18" (450 mm).		

1 In accordance with the current CSA-B149 Installation Codes

2 In accordance with the current ANSI Z223.1/NFPA 54 National Fuel Gas Codes

† A vent shall not terminate directly above a sidewalk or paved driveway which is located between two single family dwellings and serves both dwellings

‡ only permitted if veranda, porch, deck or balcony is fully open on a minimum 2 sides beneath the floor:

NOTE: 1. Local codes or regulations may require different clearances.
 2. The special venting system used on Direct Vent Fireplaces are certified as part of the appliance, with clearances tested and approved by the listing agency.
 3. CFM Corporation assumes no responsibility for the improper performance of the appliance when the venting system does not meet these requirements.

Fig. 9 Vent termination clearances.

Termination Clearances

Termination clearances for buildings with combustible and noncombustible exteriors.

Inside Corner

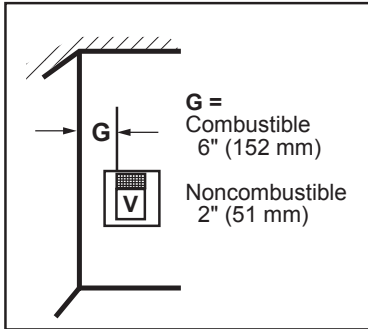

Outside Corner

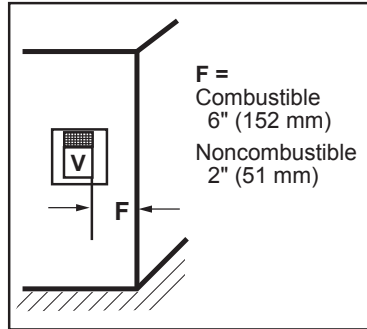

Alcove Applications*

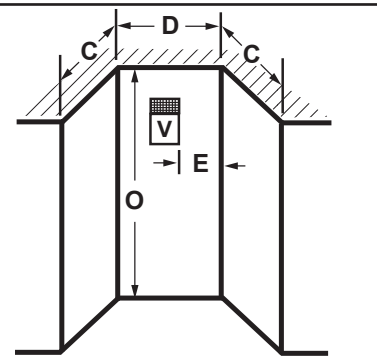

E = Min. 6" (152 mm) for non-vinyl sidewalls
Min. 12" (305 mm) for vinyl sidewalls
O = 8' (2.4 m) Min.

Balcony - with no side wall

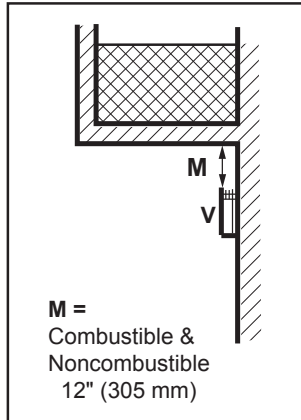

M = Combustible & Noncombustible 12" (305 mm)

Balcony - with perpendicular side wall

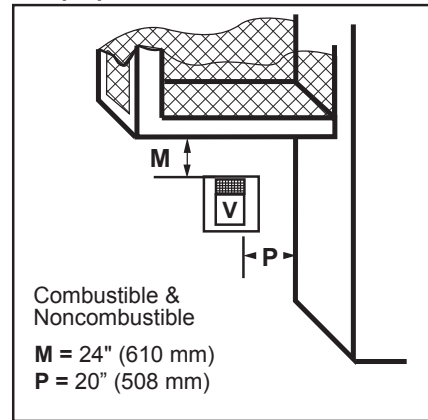

Combustible & Noncombustible
M = 24" (610 mm)
P = 20" (508 mm)

No. of Caps	D _{Min.}	C _{Max.}
1	3' (914 mm)	2 x D _{Actual}
2	6' (1.8 m)	1 x D _{Actual}
3	9' (2.7 m)	2/3 x D _{Actual}
4	12' (3.7 m)	1/2 x D _{Actual}

D_{Min.} = # of Termination caps x 3
C_{Max.} = (2 / # termination caps) x D_{Actual}

584-15

***NOTE:** Termination in an alcove space (spaces open only on one side and with an overhang) is permitted with the dimensions specified for vinyl or non-vinyl siding and soffits. 1. There must be a 3' (914 mm) minimum between termination caps. 2. All mechanical air intakes within 10' (1 m) of a termination cap must be a minimum of 3' (914 mm) below the termination cap. 3. All gravity air intakes within 3' (914 mm) of a termination cap must be a minimum of 1' (305 mm) below the termination cap.

Fig. 10 Termination clearances.

NOTE: Use only venting systems and components as certified with the appliance. Use of uncertified vent systems or components will void the warranty and may compromise the operation of the fireplace, its systems, and components as certified with the appliance.

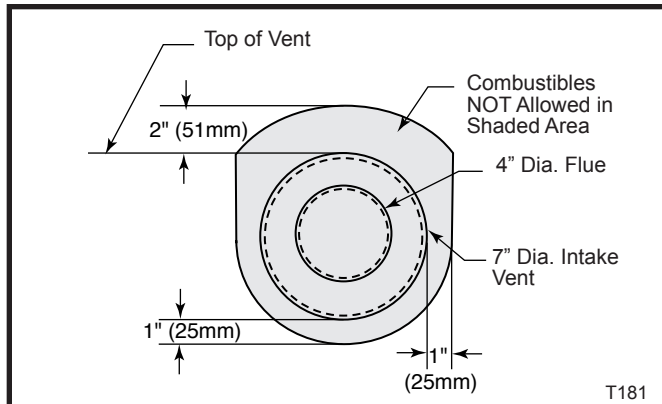

Fig. 11 Vent clearances.

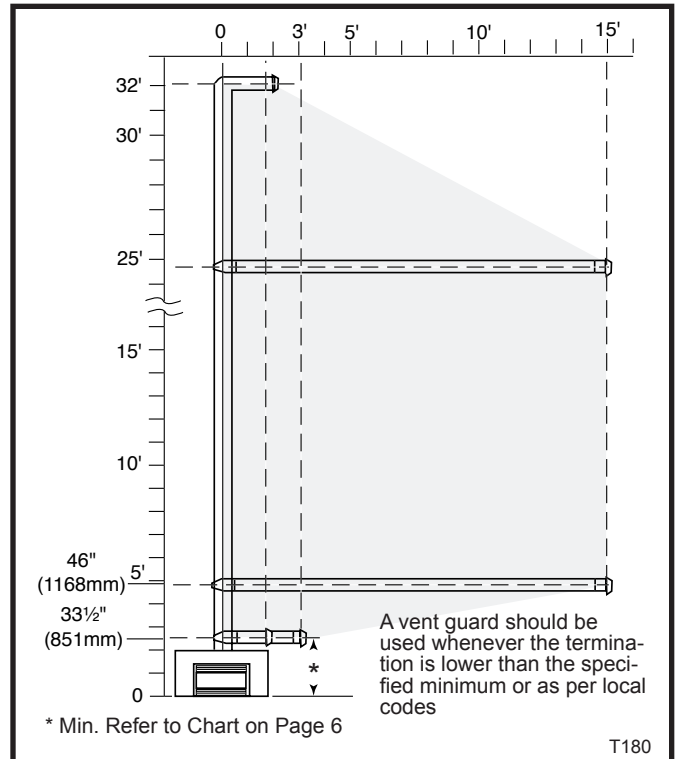

Fig. 12 Venting graph.

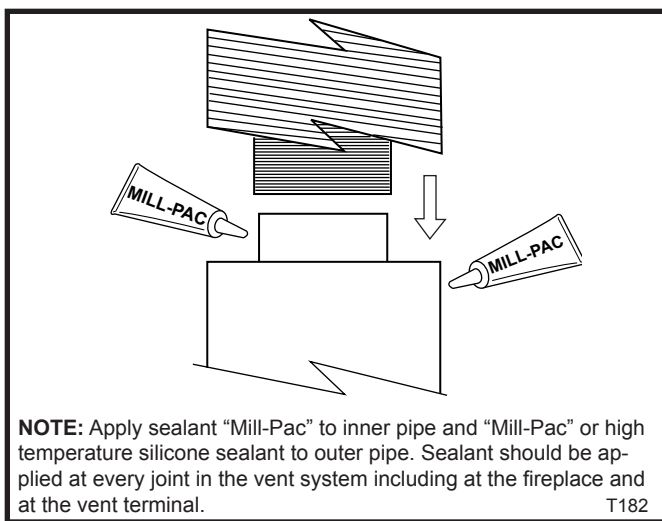
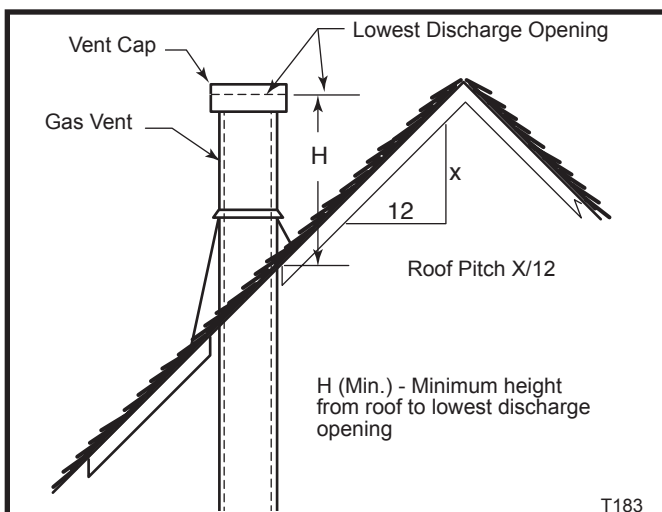

Fig. 13 Apply sealant at every joint in vent system.



Roof Pitch	H (Min.)
Flat to 6/12	12" (305 mm)
6/12 to 7/12	15" (381 mm)
Over 7/12 to 8/12	18" (457 mm)
Over 8/12 to 16/12	24" (610 mm)
Over 16/12 to 21/12	36" (914 mm)

Fig. 14 Vertical termination location.

Sidewall (General) Venting Information

Figures 15 and 16 show examples of horizontal termination arrangements using two 90° elbows (Rigid Vent).

NOTE:

1. A maximum of two 90° elbows are permitted.
2. A minimum of 10' (3 m) vertical from base of unit is required if two 90° elbows are used.
3. Minimum distance between elbows is 2' (610 mm).
4. Determine the permitted range of horizontal termination arrangement by using chart above and deducting 3' (914 mm) from the maximum horizontal distance for the second 90° elbow.

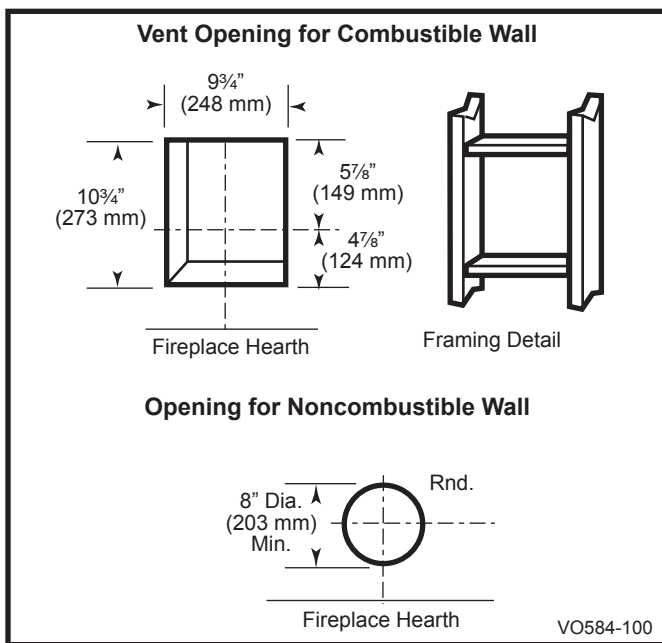

Fig. 15 Locate vent opening on wall.

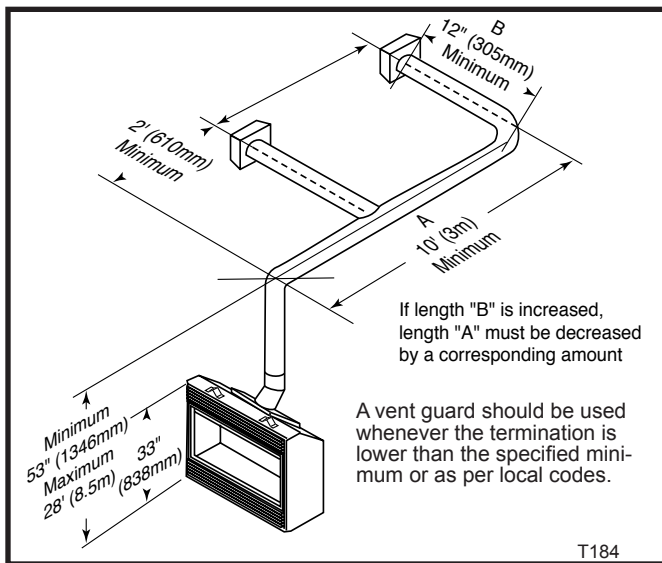

Fig. 16 Horizontal vent run.

Flex Venting

- Flex vent shall use the spacer springs as included every foot to ensure proper vent operation.
- The 4" x 7" flex system may be used for all sidewall applications and vertical venting up to 35' (10.7 m).
- Flex shall be properly supported so there are no sags in the system. Supports must be used at least every 24" (610 mm) on horizontal section and every 36" (914 mm) on vertical. Wire or metal stripping may be used to support the venting.
- For 4" x 7" flex, the 7" flex has an outside diameter of 7 1/2" (191 mm) and if installed in a chase the inside diameter of the chase should be 9 1/2" (241 mm) minimum.

- Lengths of co-axial flex may be joined together using a flex connector kit (GFPVCK) only, maximum 1 kit per installation.

An extension collar is included with side wall cap kits to simplify the connection of the flex pipe to the fireplace. Refer to Page 14, Figure 22.

ATTENTION: Spacer springs must be installed when installing flexible venting systems.

Wrap spacer spring around flex flue pipe and overlap spring ends approximately 2" (610 mm). Tie one end over the other like a shoelace tie, then reverse direction of spring ends. Lift up hooped spring and slide both spring ends underneath hooped spring. Spring spacers should be spaced at approximately 12" (305 mm) intervals for the length of pipe system. Once the springs are placed around the flue pipe, slide the flue section with spacer springs into the outer flex pipe.

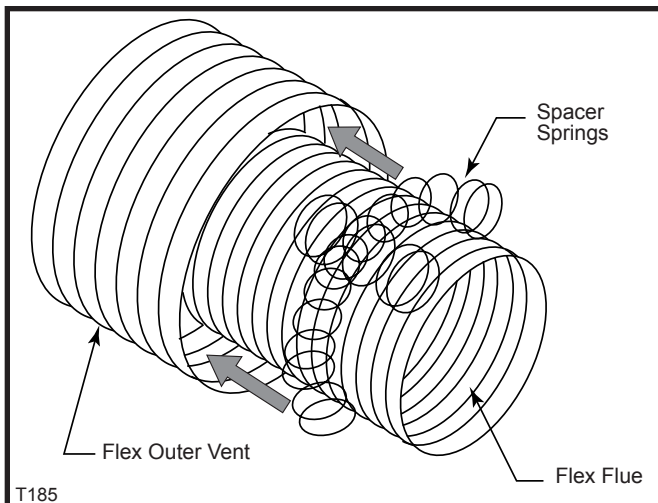

Fig. 17 Wrap spacer spring around flex flue pipe, overlapping ends.



CAUTION: Care must be taken when tightening clamps so the flex does not tear at clamp location.

Sidewall (Horizontal) Venting

For side wall (Horizontal) venting, this appliance is approved for use with a 7" x 4" flexible venting system with spacers.

Clearance to combustible material from the pipe is 1" (25 mm). Sides and bottom, 2" clearance from the top.

NOTE: O.D. of pipe is 7½" (191 mm).

Horizontal Vent Kits

◆ CDV-HSK (Round Termination Cap)

The vent starter kit contains the following:

- Horizontal termination
- Wall thimble
- 36" of 7" x 4" flex with spacers and clamps.
- Extension collar

◆ HFTK (Trapezoid Termination Cap)

The vent starter kit contains the following:

- Horizontal termination
- Wall thimble
- Extension collar

NOTE: HIGH WIND AREAS All termination caps are tested and certified for wind conditions up to 40 mph (64 k/h).

A Vinyl Extension Frame Kit No. VEF is required for all installations where vinyl siding is used with the HFTK Kit or HSQ47 Horizontal Vent Termination. If a Vinyl Extension Frame Kit No. VEF is used, measure to outside surface of wall without siding and add 2 additional inches (51 mm) to the venting length.

A brick extension kit No. BEF is available to extend the horizontal vent terminal HSQ47 or HFTK kit terminal beyond the brick surface. If the BEF extension is used, measure to the outside surface of the framed wall and add 4 additional inches to the venting length.

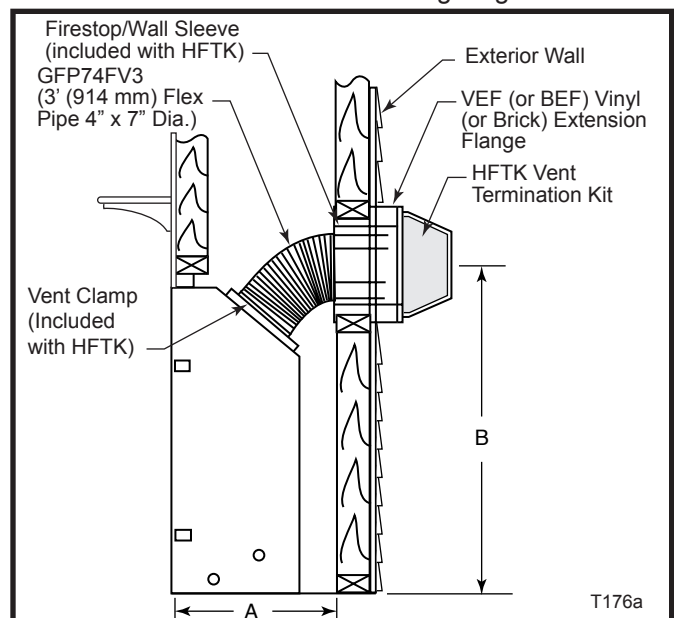

NOTE: Typical terminal height "B" is 48" for model DV1000, 60" for models DV1200 and DV1400 with dimension "A" up to 36". Please refer to minimum framing dimensions with horizontal venting chart on Page 5.

Fig. 18 Typical direct vent gas fireplace with horizontal venting.

Flex Vent Offsets

Each installation assumes the use of (1) 45° (bend) starting off top of unit.

To determine the amount or length of flex vent you need for a given installation, add the total offset dimension to the total rise needed. Then add 1 ft. (305 mm) for every 45° bend and/or 2' (610 mm) for each 90° bend.

No more than (4) 90° and (2) 45° offsets are to be used per installation. Vent terminal cap location should be in accordance with the Venting Graph chart and the Vertical Termination Location information.

1. Measure the total wall thickness. Determine whether or not the thimble extension is needed. If the combustible wall depth is over 5" (127 mm), the extension should be used. (Fig. 19)
2. Assemble wall thimble with thimble extension flange to top. Mate thimble to wall plate with the four tabs provided. Bend tabs over to secure. (Fig. 19)

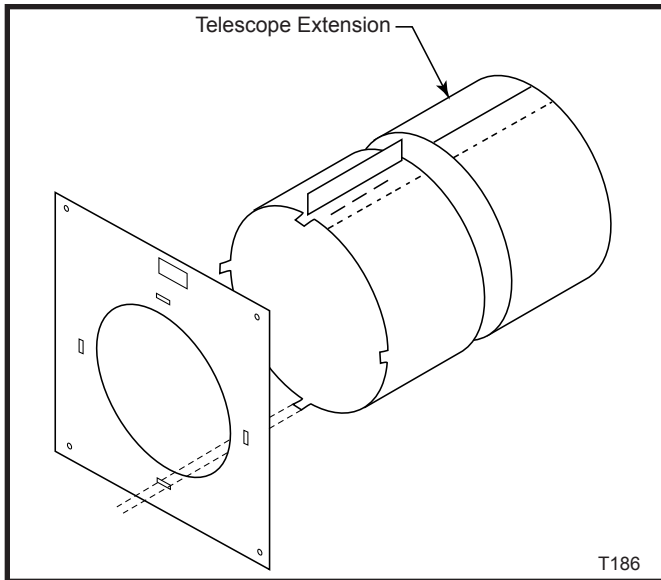

Fig. 19 The telescope extension must be used if wall thickness is over 5" (127 mm).

3. Install the wall thimble assembly through the framed opening so the firestop plate is on the interior wall. (Fig. 20) Telescope section should extend all the way through wall.
4. Step 1: Apply Mill-Pac to 4" flue inner pipe on cap.
Step 2: Connect 4" flex flue to flue on cap with band clamp.
Step 3: Apply silicone sealant to 7" outer pipe on cap.
Step 4: Slide 7" outer flex over inlet and secure with band clamp.
5. Secure vent cap terminal to exterior wall with screw type fasteners as needed. (Fig. 21)
6. Connect corrugated side of the extension collar (7" dia.) into the 7" dia. flex pipe. (Fig. 22) Place a small bead of silicone around the collar approximately 1/4" from the leading edge of the corrugation. Insert the collar firmly into the flex pipe and secure with the provided (7" dia.) band clamp.
7. Place a small mill-pac bead around the top edge of the fireplace flue collar. Then, attach the flex tube over the flue collar with a 4" dia. band clamp.

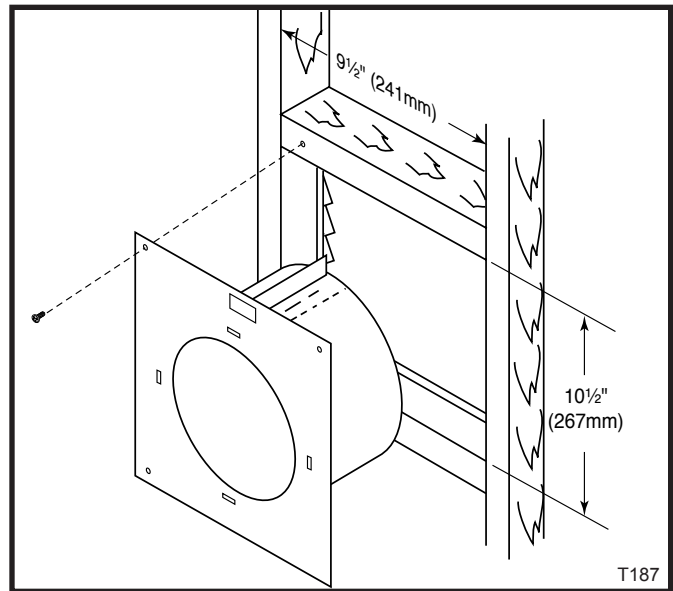

Fig. 20 Install wall thimble with firestop on interior wall.

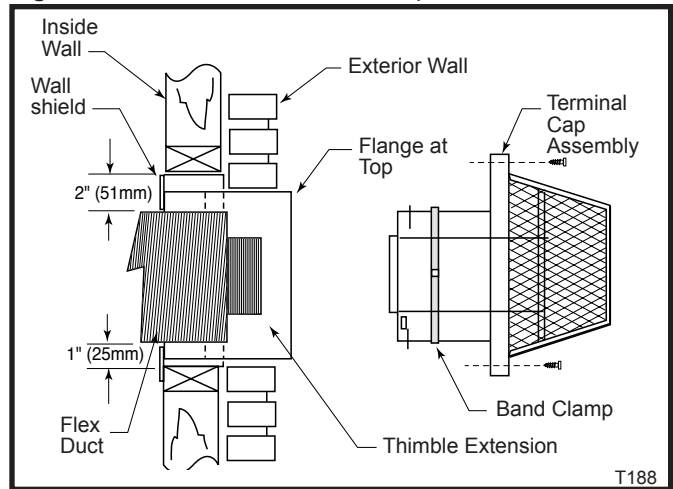

Fig. 21 Secure vent cap terminal to exterior wall.

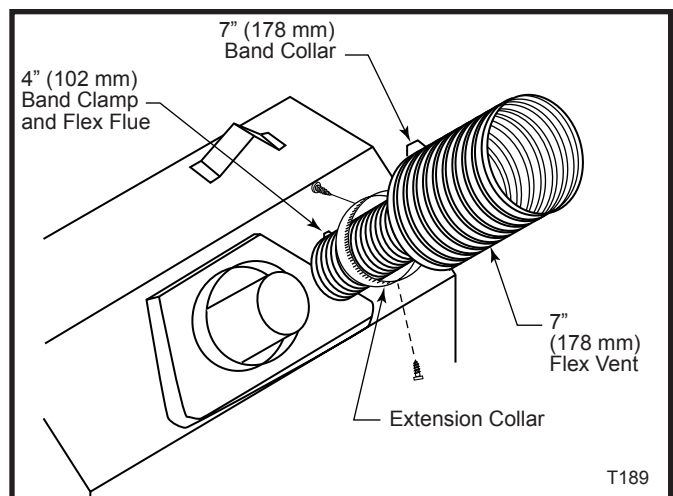

Fig. 22 Insert collar into flex pipe and secure with band clamp.

ATTENTION: Spacer springs must be installed when installing flexible venting system.

- To finish connections, place a small bead of silicone to the outside of the fireplace inlet flange. Then, slide the extension collar over the inlet flange and secure with the three (3) screws provided.

NOTE: We recommend driving in two (2) sheet metal screws at 180° adjacent to the gear clamp at each joint.

Flex Vent Through the Roof (Vertical) Applications

All models are approved for:

- Vertical venting up to 35' (10.7 m) with 7" x 4" flex.
- Multiple bends allowed. See section on General Venting.
- With each vertical installation, a VSK7MH-2 kit may be used.

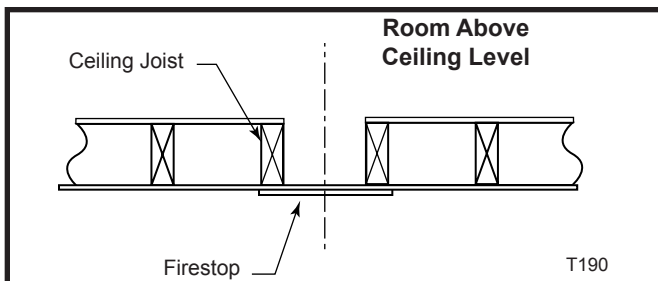

Fig. 23 Firestop at ceiling level.

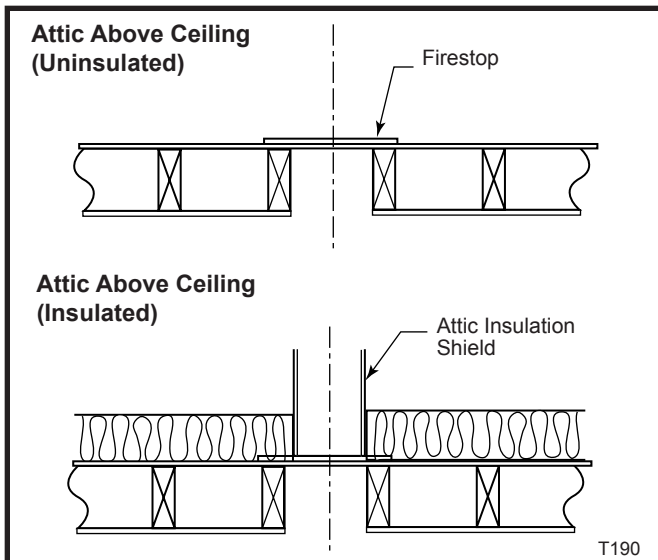

Fig. 24 Attic insulation shield.

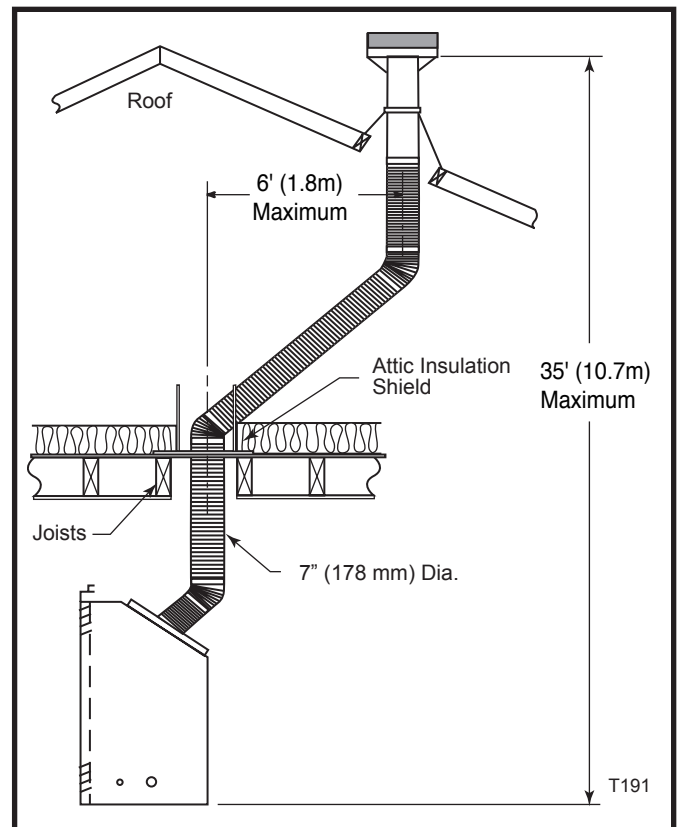

Fig. 25 Typical through-the-roof installation.

The VSK7 Kit contains:

- Vertical Termination Cap and Storm Collar
- 4" / 7" dia. x 24" Rigid Pipe (united)
- 7" dia. Roof Support Components
- 0/12-5/12 Flashing with Storm Collar
- Tube High Temp Sealant
- 7" dia. Inlet Ext. Collar
- Firestop
- Hardware Pack
- Instruction

VSK7 Vertical Flex Vent Kit Installation

1. Locate the fireplace.
 2. Mark ceiling above unit where flex will come through.
- *-REFER TO VERTICAL TERMINATION LOCATION CHART**
3. Ceiling opening should be a minimum of 9½" x 9½" (241 x 241 mm) and framed to that size.
 4. Mark opening in roof and cut a hole minimum 9½" x 9½" (241 x 241 mm) and frame to that size.
 5. Place fireplace in proper location and secure to the floor.
 6. Install the firestop at the ceiling level.
 7. If an attic space (insulated or not) is located above the ceiling, the firestop should be installed to the underside of the ceiling. The firestop maintains the proper air-space clearance from the vent to insula-

tion and building materials. An attic insulation shield (AS7-8) may be used above the firestop to keep attic insulation spaced away from the vent system.

8. Rigid pipe section included with vertical termination must be used in conjunction with the roof support so that the termination is secure in winds. All vent kit components can be assembled on the ground first, then lift complete assembly onto the roof and feed flex vent down thru the roof opening and firestop thimble assembly. Then trim off unneeded flex at unit and make the connection at the fireplace flue and inlet collars. Make sure vent cap will be in accordance with the vertical termination location chart. Install the roof flashing below the shingles across the top half, and above the shingles on the lower half.
9. Install storm collar and caulk around the pipe.

TDV Series Direct Vent System Installation

- The TDV series vent system is specifically approved only for Temco Direct-Vent fireplace models with a 4" (102 mm) diameter flue and a 7" (178 mm) diameter inlet vent system. The use of uncertified venting will void warranties and may compromise the operation and safety of the appliance.
- Termination shall not be recessed into a wall or siding.
- The vent system shall be properly supported so there are no sags in the system. Supports must be used at least every 3' (914mm) on horizontal section and every 6' (1.8m) on vertical.
- Horizontal sections must maintain a minimum 1/4" rise per linear foot of horizontal run.
- Combustible clearances from any horizontal vent pipe area must be 2" (51mm) from top of vent, and 1" (25mm) from sides and bottom.
- Clearance to combustibles from vertical pipe surface is 1" (25mm).
- Prior to securing each vent component, make sure the sections are pushed together firmly to maintain vent integrity.

Sidewall (Horizontal) Venting, General

When locating the vent termination, the minimum vent clearances must be observed.

NOTE: Local codes may require different clearances.

It is recommended that the termination not be located within 24" (610 mm) of garden sheds, fences, decks, utility buildings or other obstructions.

Review the "vent termination" section in the appliance installation instructions.

Do not locate vent terminal where excessive snow or ice build up may occur. Be sure to check vent termination area after snow falls and clear to prevent accidental

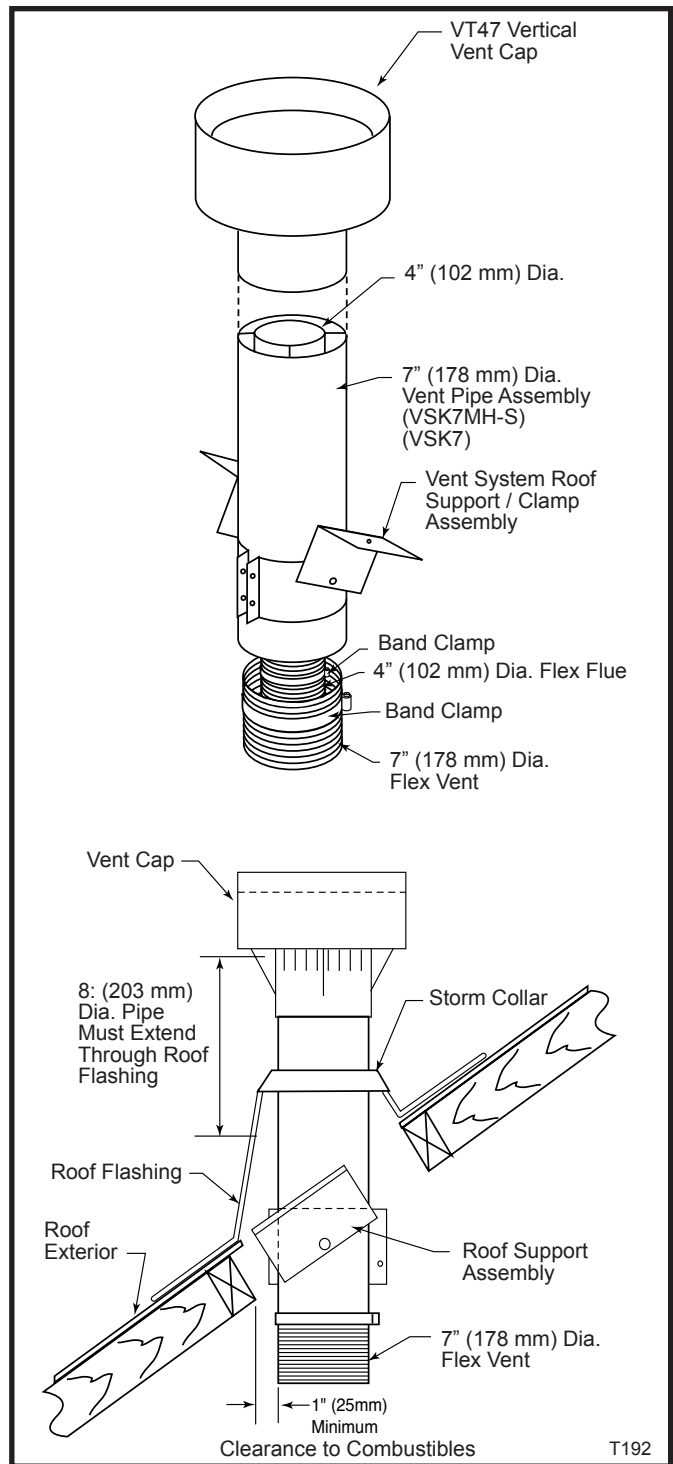

Fig. 26 Through the roof installation.

NOTE: If offset is required, the upper 45° bend (elbow) must be supported with an offset support. Support flex every 3' (914 mm) when vertical venting.

blockage of venting system. When using snow blowers, make sure snow is not directed towards vent termination area.

The TDV series is considered a “special vent system”. Check with local codes or in the absence of same, with CSA B149.1 installation codes regarding special vent termination clearances.

NOTICE: Flexible and rigid vent system components are not interchangeable unless otherwise specified in the venting instructions.

NOTICE: Additional venting information regarding clearances, terminal locations, and safety information is contained in the installation and operating instructions packaged with the appliance.

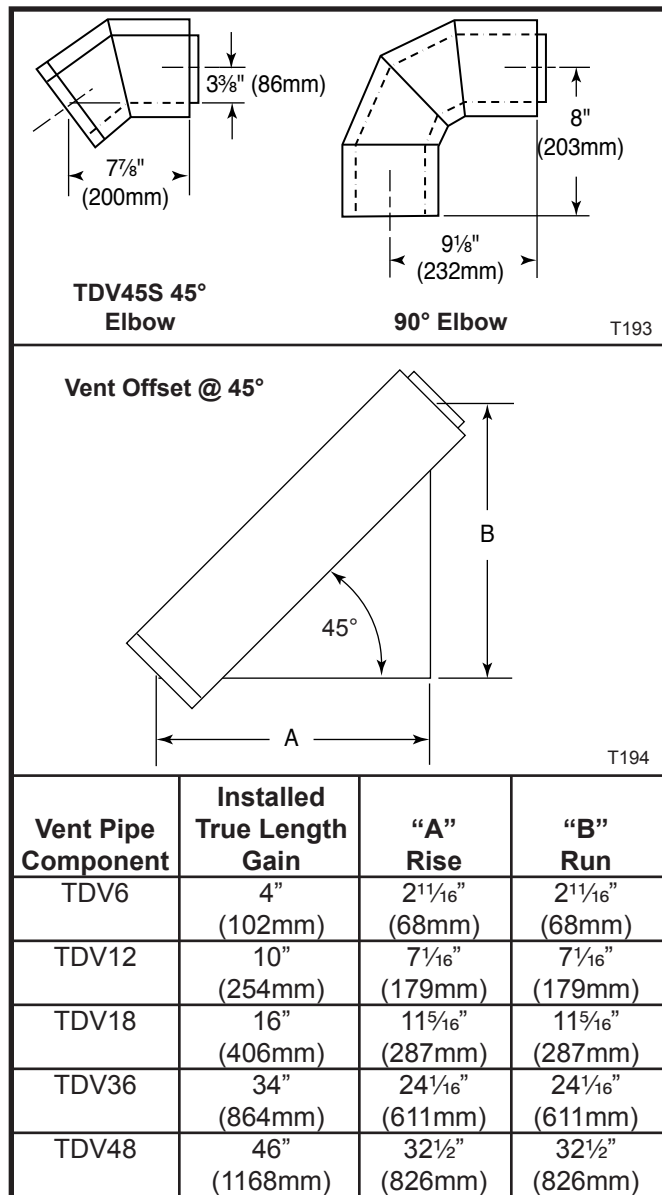

IMPORTANT: Do not mix vent system components with components for other vent systems.

NOTE: Use only venting systems and components as certified with the appliance. Use of uncertified vent systems or components will void the warranty and may compromise the operation of the fireplace, its systems, and components as certified with the appliance. Use of uncertified vent systems or components will void the warranty and may compromise the operation of the fireplace.

Through the Roof (Vertical) Venting

When the venting penetrates a roof the system must be installed in accordance with the current CSA B149.1 installation code (in Canada) or the current National Fuel Gas Code, ANSI Z223.1/NFPA 54 (in U.S.A.). SEE CHART FOR VERTICAL TERMINATION LOCATION.

Elbows & Offsets - General

Each installation assures the use of one 45° elbow horizontal or vertical (off top of unit).

Sidewall (Horizontal) Venting Information

1. Make sure fireplace location and termination location are consistent with requirements for terminations and vent runs.
2. Secure unit to the floor.
3. Locate vent opening in wall. Maintain 2” (51 mm) clearance to top of vent from combustibles. Install wall thimble per instructions supplied with Horizontal Vent Kit. Refer to Page 14, Figures 19 and 20 for wall thimble installation.
4. Attach vent components beginning with a TDV45S elbow. Apply high temperature sealant to the outside leading edge of the fireplace flue pipe, then install the TDV45S starter elbow and secure it to the fireplace with the three (3) screws (provided) through the outer pipe flange and into the fireplace 7” (178 mm) dia. starter flange.

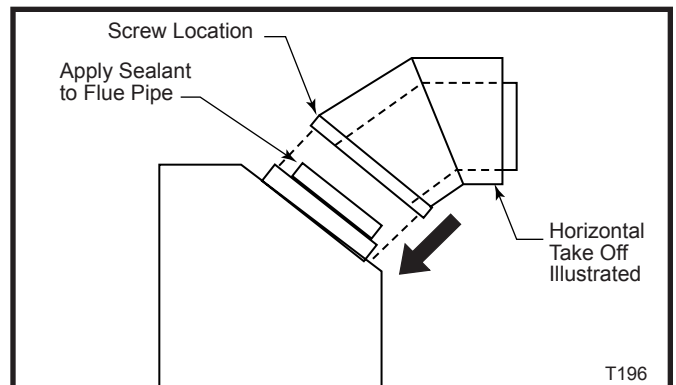

Fig. 27 Apply high temperature sealant to outside of the flue pipe.

5. Align the flue and inlet pipes of each vent section to the mating component, then slide the sections together. Before a joint in the system is secured, push the vent components together using moderate force to ensure joint overlap of approximately 1½" (38 mm).
6. Secure vent components with a minimum of three (3) screws at each joint (pipe joint to pipe, joint sealants are not required). Never use screws in vent systems longer than 1" (25 mm).
7. Vent sections and elbows may be rotated 360° prior to securement to obtain the desired direction of vent run, and provide flexibility.
8. Make sure all horizontal sections have no sags and maintain a minimum 1/4" (6 mm) rise per linear foot.
9. Using the high temperature sealant provided, apply a small bead of sealant to both the flue and inlet pipe extensions on the vent terminal (cap) and install the horizontal vent terminal to side of building with four (4) screws provided.
10. If the last section of vent pipe does not allow the vent terminal to seat against the outside wall, it will be necessary to replace the last vent section with a shorter vent section. In addition, you may also measure the distance between the wall and back flanges of the terminal base plate. Next, trim off the terminal flue and inlet pipes to the dimension measured and reinstall the vent terminal.

ATTENTION: Vent terminal flue and inlet pipes must overlap last vent section a minimum of 1" (25 mm).

If the horizontal termination is located in an accessible area below 7" (178 mm), an HTG guard is to be installed over terminal.

A Vinyl Extension Frame Kit No. VEF is required for all installations where vinyl siding is used with the HFTK Kit or HSQ47 Horizontal Vent Termination. If a Vinyl Extension Frame Kit No. VEF is used, measure to outside surface of wall without siding and add an additional 2" (51 mm) to the venting length.

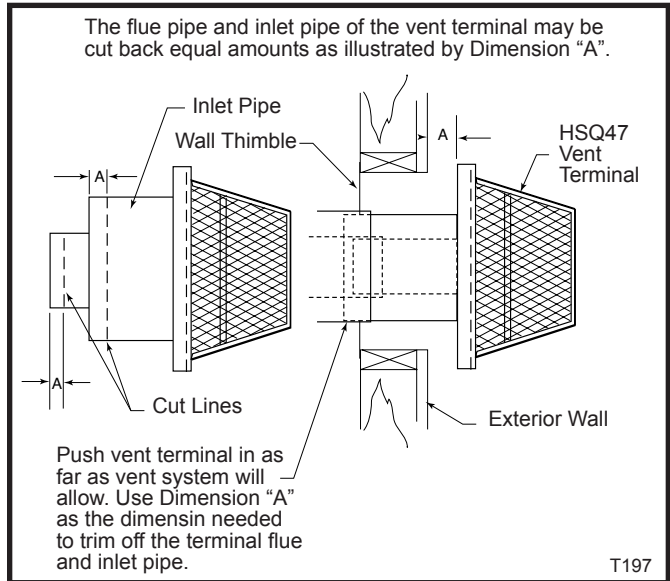
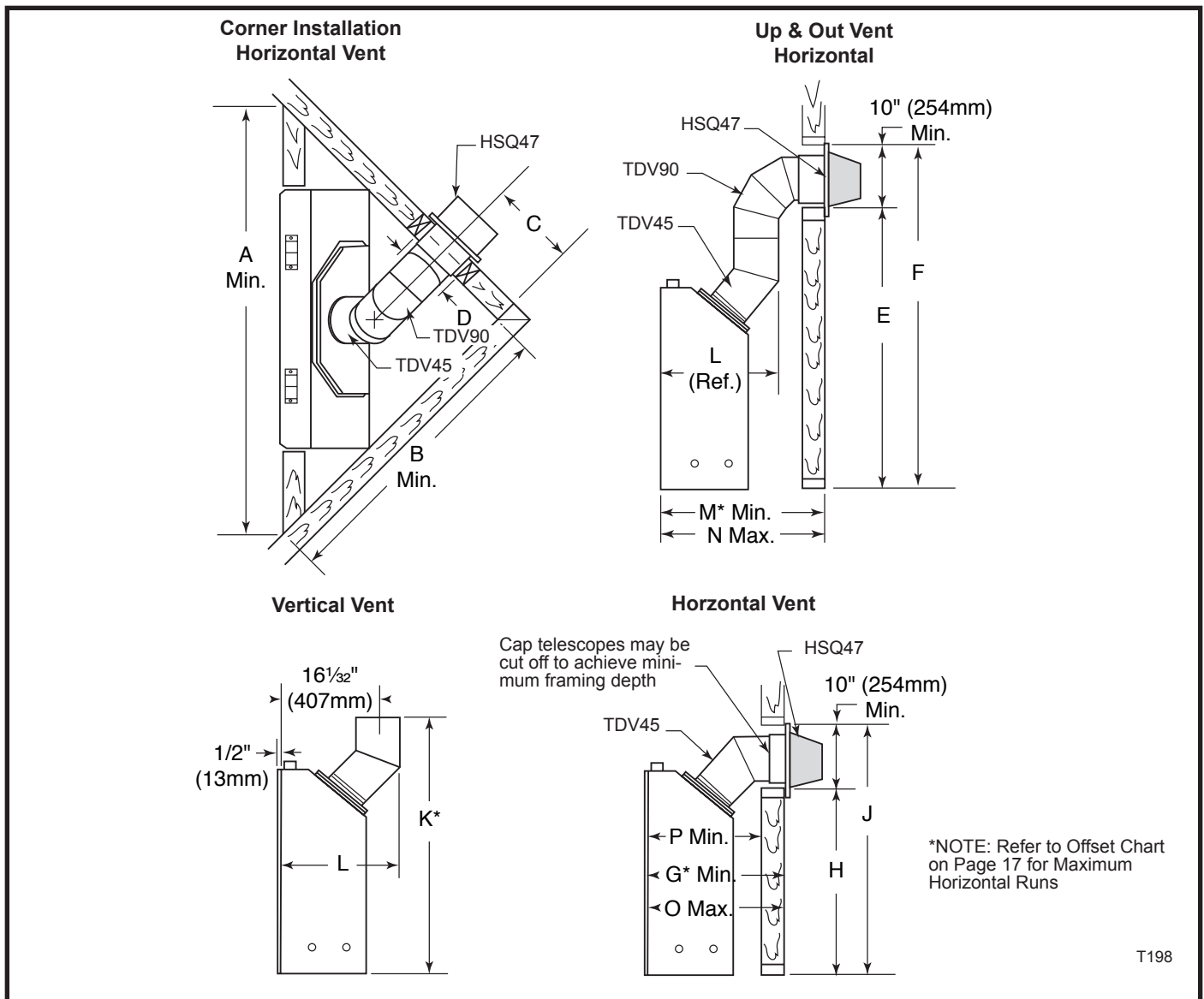

Fig. 28 Cut the terminal flue and inlet pipes to shorten the vent section.



T198

Fig. 29 Typical TDV Series vent applications.

Ref.	DV1000	DV1200	DV1400
A	63 ⁵ / ₃₂ " (1604 mm)	64 ²⁹ / ₃₂ " (1633 mm)	71 ³ / ₁₆ " (1808 mm)
B	44 ¹¹ / ₁₆ " (1135 mm)	45 ⁷ / ₈ " (1165 mm)	50 ⁵ / ₁₆ " (1295 mm)
C	9 ¹ / ₃₂ " (237 mm)	12" (305 mm)	14 ¹ / ₈ " (359 mm)
D	9 ⁷ / ₁₆ " (240 mm)	9 ⁷ / ₁₆ " (240 mm)	9 ⁷ / ₁₆ " (240 mm)
E	37 ¹ / ₂ " (953 mm)	42 ¹ / ₂ " (1080 mm)	42 ¹ / ₂ " (1080 mm)
F	48 ¹ / ₄ " (1226 mm)	53 ¹ / ₄ " (1353 mm)	53 ¹ / ₄ " (1353 mm)
G	18 ³ / ₄ " (476 mm)	20" (508 mm)	20" (508 mm)
H	25 ¹ / ₂ " (648 mm)	30 ⁹ / ₈ " (778 mm)	30 ⁹ / ₈ " (778 mm)
J	36 ¹ / ₄ " (921 mm)	41 ³ / ₈ " (1051 mm)	41 ³ / ₈ " (1051 mm)
K	34 ¹ / ₄ " (870 mm)	39 ³ / ₈ " (1000 mm)	39 ³ / ₈ " (1000 mm)
L	17 ⁷ / ₈ " (454 mm)	19 ¹ / ₂ " (495 mm)	19 ¹ / ₂ " (495 mm)
M	24" (610 mm)	25 ¹ / ₄ " (641 mm)	25 ¹ / ₄ " (641 mm)
N	28 ³ / ₈ " (721 mm)	30" (762 mm)	30" (762 mm)
O	23 ¹ / ₄ " (591 mm)	24 ¹ / ₂ " (622 mm)	24 ¹ / ₂ " (622 mm)
P	15 ¹ / ₄ " (387 mm)	16 ¹ / ₂ " (419 mm)	16 ¹ / ₂ " (419 mm)

Simpson Dura-Vent Venting Horizontal or Vertical Terminations

The Simpson Dura-Vent Direct Vent System (GS 4" x 6⁵/₈") offers a complete line of component parts for installation of both horizontal and vertical installations. Many items are offered in decorative black, as well as galvanized finish. The galvanized finish may be used for installation with your Temco gas fireplace.

The minimum components required for a basic horizontal termination are:

- 1 Horizontal Termination Cap
- 1 Flue Adapter (45° Elbow)
- 1 Wall Penetration Heat Shield
- 1 Length of pipe to suit wall thickness (see chart)

Wall thickness is measured from the back of the fireplace to the inside mounting surface of termination cap. For siding (other than vinyl) furring strips may be used, instead of the vinyl siding standoff, to create a level surface to mount the vent terminal. The Terminal must not be recessed into siding. Measure the wall thickness including furring strips.

If a Vinyl Siding Standoff is required (it must be used with vinyl siding), measure to outside surface of wall without siding and add 2" (51 mm).

Flat Wall Installation (All Units)	
Wall Thickness	Vent Length
inches (mm)	Required (inches(mm))
5½" - 7" (140 - 178 mm)	- -
9½" - 11" (241 - 279 mm)	6" (152 mm)
12½" - 14" (318 - 356 mm)	9" (229 mm)
15½" - 17" (394 - 432 mm)	12" (305 mm)
14½" - 19 ⁵ / ₈ " (368 - 499 mm)	11" - 14 ⁵ / ₈ " Adj. Pipe (279 - 372 mm)
20½" - 29" (520 - 737 mm)	17" - 24" Adj. Pipe (432 - 610 mm)
Corner Installation (DV1000)	
2¾" - 4¼" (70 - 108 mm)	6" (152 mm)
5¾" - 7¼" (146 - 184 mm)	9" (229 mm)
9¾" - 11¼" (248 - 286 mm)	6" + 9" (152 mm + 229 mm)
12¾" - 14¼" (324 - 362 mm)	6" + 12" / 9" + 9" (152 + 305 mm) (229 + 229 mm)
13¾" - 22¼" (349 - 565 mm)	17" - 24" Adj. Pipe (432 - 610 mm)
7¾" - 12 ⁷ / ₈ " (197 - 327 mm)	11" - 14 ⁵ / ₈ " Adj. Pipe (279 - 372 mm)
Corner Installation (DV1200)	
2 ³ / ₁₆ " - 3 ¹ / ₁₆ " (56 - 94 mm)	6" (152 mm)
5 ³ / ₁₆ " - 6 ¹ / ₁₆ " (132 - 170 mm)	9" (229 mm)
8 ³ / ₁₆ " - 9 ¹ / ₁₆ " (208 - 246 mm)	12" (305 mm)
9 ³ / ₁₆ " - 10 ¹ / ₁₆ " (233 - 272 mm)	6" + 9" (152 + 229 mm)
12 ³ / ₁₆ " - 13 ¹ / ₁₆ " (310 - 347 mm)	6" + 12" / 9" + 9" (152 + 229 mm) / (229 + 229 mm)
13 ³ / ₁₆ " - 21 ¹ / ₁₆ " (335 - 551 mm)	17" - 24" Adj. Pipe (432 - 610 mm)
7 ³ / ₁₆ " - 12 ⁵ / ₁₆ " (183 - 313 mm)	11" - 14 ⁵ / ₈ " Adj. Pipe (279 - 372 mm)
Corner Installation (DV1400)	
7 ¹ / ₈ " - 8 ⁵ / ₈ " (181 - 219 mm)	6" + 9" (152 + 229 mm)
10 ¹ / ₈ " - 11 ⁵ / ₈ " (257 - 295 mm)	6" + 12" / 9" + 9" (152 + 229 mm) / (229 + 229 mm)
11 ¹ / ₈ " - 19 ⁵ / ₈ " (283 - 499 mm)	17" - 24" Adj. Pipe (432 - 610 mm)
5 ¹ / ₈ " - 10¼" (130 - 260 mm)	11" - 14 ⁵ / ₈ " Adj. Pipe (279 - 372 mm)

Flexible Venting Individual System Components

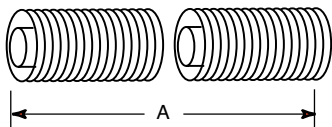

Vent Kit	A
GFP74FV3	3' (914 mm)
GFP74FV10	10' (3 m)
GFP74FV20	20' (6 m)
GFP74FV30	30' (9 m)

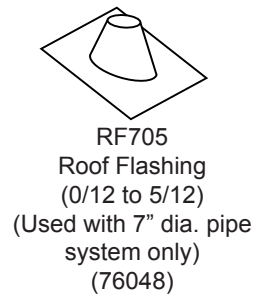
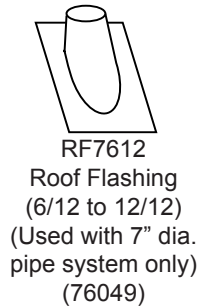
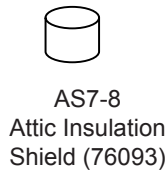
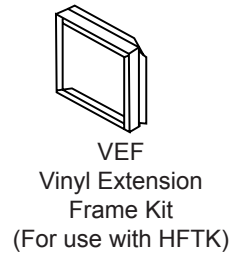
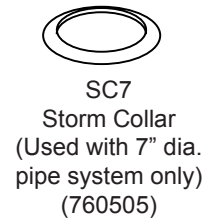

T199

Temco Flex Vent Termination Kits Available

Square Horizontal Cap (uses 7/4 Flex)	HFTK
Round Hor. Term. Cap (High Wind) (Includes 7/4 Flex x 3 ft. long)	CDV-HSK
Round Hor. Term. Cap (uses 7/4 Flex)	RN47
Vertical Vent Kit (Includes 7/4 flex x 10 ft. long, Firestop Thimble Assy)	VSK7MH-2
Vertical Vent Kit (uses 7/4 Flex)	VSK7

TDV Series Direct-Vent System Installation

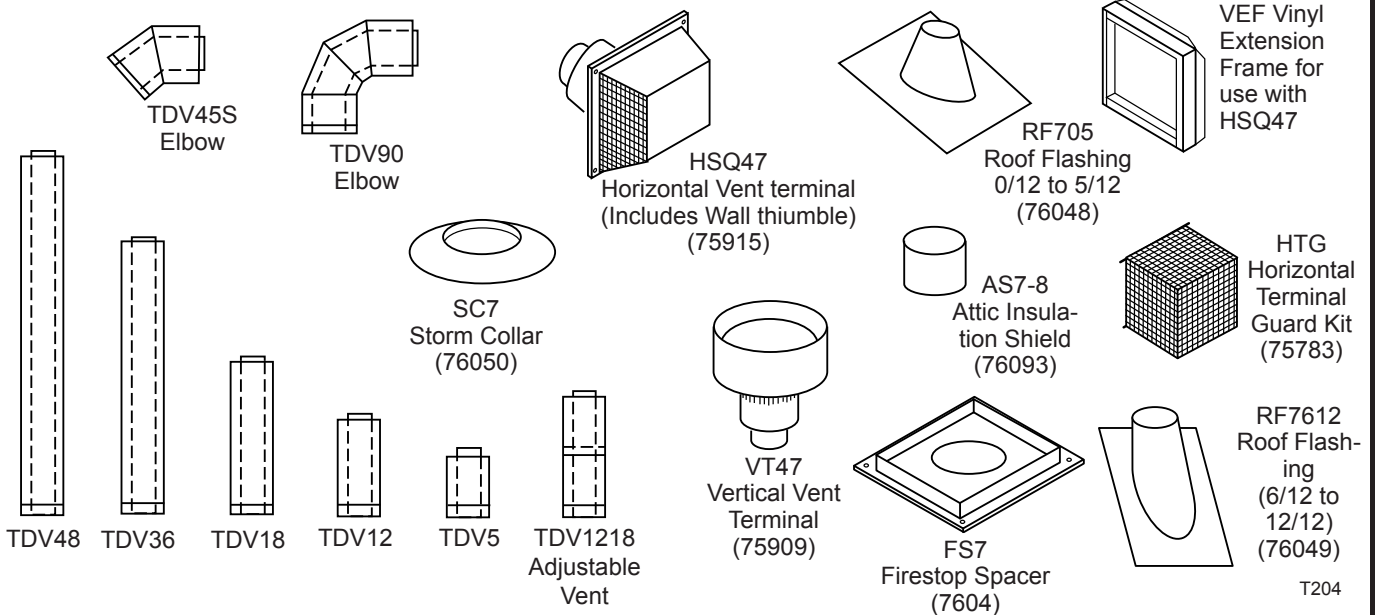

NOTE: Flexible and rigid vent system components are NOT interchangeable unless otherwise specified in the venting instructions.

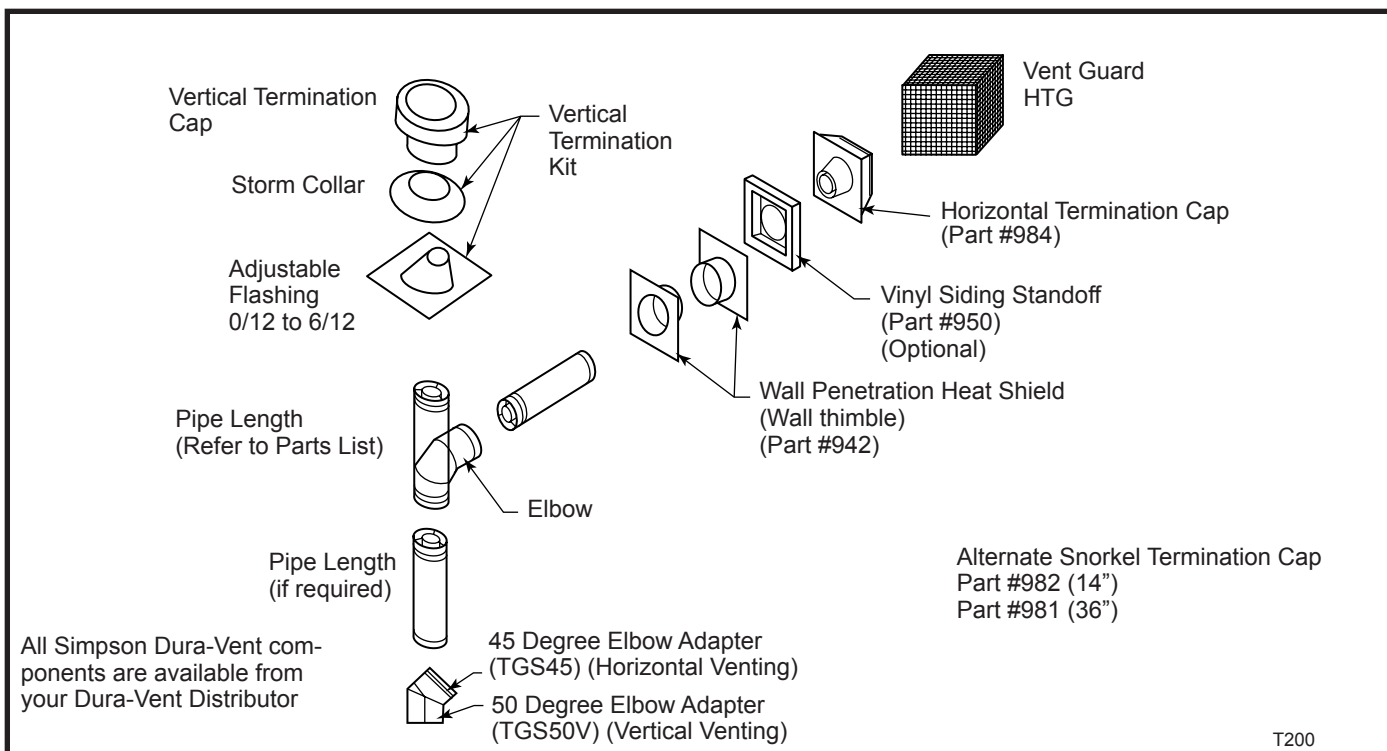

All Simpson Dura-Vent components are available from your Dura-Vent Distributor

T200

Horizontal Termination Kit	971	45° Elbow, Swivel - Galvanized	945G
Includes: 90° Black Elbow		45° Elbow, Swivel - Black	945BG
Wall Thimble Cover		90° Elbow - Galvanized	990
Horizontal Square Termination Cap		90° Elbow, Swivel - Galvanized	990G
24" Black Pipe		90° Elbow, Swivel - Black	990BG
11" - 14 ⁵ / ₈ " Adjustable Black Pipe		High Wind Termination Cap (Vertical)	991
Basic Horizontal Termination Kit	970	Vertical Termination Cap	980
Includes: 90° Black Elbow		Horizontal Square Termination Cap	984
Wall Thimble Cover		Horizontal Square Termination Cap w/1" return	984L
Horizontal Square Termination Cap		Horizontal Square High Wind Termination Cap	985
Vertical Termination Kit	978	Snorkel - 14" Rise Termination Cap	982
Includes:		Snorkel - 36" Rise Termination Cap	981
0-12 - 6/12 Pitch Adjustable Flashing		Wall Thimble - Support/Box	940
Storm Collar		Cathedral Ceiling - Support/Box	941
Low Profile Termination Cap		Brass Trim for Cathedral	3951
6" Pipe Length - Black	908B	Firestop Spacer	963
9" Pipe Length - Black	907B	Flashing 0/12 - 6/12 Roof Pitch	943
12" Pipe Length - Galvanized	906	Flashing 7/12 - 12/12 Roof Pitch	943S
12" Pipe Length - Black	906B	Storm Collar	953
24" Pipe Length - Galvanized	904	Vinyl Siding Standoff	950
24" Pipe Length - Black	904B	Wall Strap	988
36" Pipe Length - Galvanized	903	Wall Penetration Heat Shield (Wall Thimble)	942
36" Pipe Length - Black	903B	Parts Available from TEMCO (Not supplied by Dura-Vent)	
48" Pipe Length - Galvanized	902	Vent Guard	HTG
48" Pipe Length - Black	902B	45° Adapter Elbow (Horizontal Venting)	TGS45
11" - 14⁵/₈" Adjustable Pipe - Black	911B	50° Adapter Elbow (Vertical Venting)	TGS50V
17" - 24" Adjustable Pipe - Black	917B		
45° Elbow - Galvanized	945		
45° Elbow - Black	945B		

Secure Vent Venting Components

Standard Horizontal Kit	SV0SHK	1½" - 6" Adjustable Pipe - Black	SV4LBA
Includes: 90° Swivel Black Elbow		1½" - 6" Adjustable Pipe - Galvanized	SV4LA
Decorative Black Plate		1½" - 12" Adjustable Pipe - Black	SV4LBA12
Horizontal Termination Cap		1½" - 12" Adjustable Pipe - Galvanized	SV4LA12
Horizontal Kit	SV0HK	1½" - 24" Adjustable Pipe - Black	SV4LBA24
Includes: 90° Swivel Black Elbow		1½" - 24" Adjustable Pipe - Galvanized	SV4LA24
Decorative black Plate		45° Elbow, Swivel - Black	SV4EB45
Horizontal Termination Cap		45° Elbow, Swivel - Galvanized	SV4E45
Adjustable Length 12"		45° Elbow - Black	SV4EBR45
Black Length 24"		90° Elbow, Swivel - Black	SV4EB90
Horizontal Kit	SV0HK2	90° Elbow - Galvanized	SV4E90
Includes: 90° Swivel Black Elbow		90° Elbow - Black	SV4EBR90
Decorative black Plate		Vinyl Shield	SV4VS
Horizontal Termination Cap		Snorkel Cap 14"	SV4STC14
Adjustable Length 12"		Snorkel Cap 36"	SV4STC36
Black Length 24"		Adjustable Decorative Square	
Wall Radiation Shield		Cathedral Support	SV4CSB
Vertical Flat Roof Kit	SV0FK	Wall Radiation Shield	SV4RSM
Flat Roof Flashing		Collar for Decorative Square	
Storm Collar		Cathedral Support	SV4AC
Vertical Termination Cap		Attic Radiation Shield	SV4RSA
Vertical Adjustable Roof Kit	SV0FAK	Adjustable Wall Band	SV4BM
1/12 - 7/12 Includes:		Roof Support	SV4ST
Adjustable Roof Flashing		Floor Support	SV4SD
(1/12 - 7/12)		Roof Brace	SV4BS
Storm Collar		Universal Support	SV4SU
Vertical Termination Cap		Flat Roof Flashing	SV4F
Vertical Adjustable Roof Kit	SV0FBK	1/12 - 7/12 Adjustable Roof Flashing	SV4FA
8/12 - 12/12 Includes:		8/12 - 12/12 Adjustable Roof Flashing	SV4FB
Adjustable Roof Flashing		Storm Collar	SV4FC
(8/12 - 12/120)		Decorative Black Plate	SV4PF
Storm Collar		Firestop	SV4BF
Vertical Termination Cap		Horizontal Termination Cap	SV4CHC
6" Pipe Length - Black	SV4LB6	Vertical Termination Cap	SV4CGV
6" Pipe Length - Galvanized	SV4L6	Restrictor Disc	SV4RD
12" Pipe Length - Black	SV4LB12	45° Adapter Elbow	
12" Pipe Length - Galvanized	SV4L12	(Horizontal Venting)	SV4E40AT*
24" Pipe Length - Black	SV4LB24		
24" Pipe Length - Galvanized	SV4L24		
36" Pipe Length - Black	SV4LB36		
36" Pipe Length - Galvanized	SV4L36		
48" Pipe Length - Black	SV4LB48		
48" Pipe Length - Galvanized	SV4L48		

*NOTE: This adapter elbow is required on all TEMCO Direct Vent Fireplaces for installation of Secure Vent Systems.

Operating Instructions

WARNING: Do not operate appliance with the glass front removed, cracked or broken.

- The use of substitute glass will void all product warranties.
- Care must be taken to avoid breakage of the glass.
- Do not operate this fireplace without the glass front or with a broken glass front.
- **Replacement of the glass should be done by a licensed or qualified service person.**
- **Do not remove the glass door when unit is hot to the touch.**
- **NOTE:** Inspect the door gasket. The braided door seal gasket has a small overlap area near corner of the top black extrusion. Identify this area and install the door with this area at the top.

Glass Door Removal Procedure

1. Remove upper and lower louvre assemblies and set aside. Refer to louvre installation instructions.
2. Using gloves, carefully unlatch the latches (3) along the bottom edge of the glass door. Then as the top latches are unlatched, continue to place gentle pressure to the glass door to reduce the chances of the door being dropped accidentally.
3. Once all latches have been secured, pull the door (4) outward from the face of the fire chamber.
4. Take care during handling and cleaning of the glass door so that it is not dropped or accidentally broken.
5. Cleaning of the glass should only be done when the glass door is cool. Refer to Glass Cleaning section.
6. To reinstall glass door, carefully center the door onto the face of the fireplace (left to right), second, shift the door assembly upwards slightly, then secure door with the throw-over latches above and below the firechamber. By shifting the door upwards before latching, the upper door latches will be less visible once the upper louvre is installed.
7. Reinstall the upper and lower louvre assemblies. Refer to louvre installation.

Glass Cleaning

It will be necessary to clean the glass periodically. During start-up, condensation - which is normal - forms on the inside of the glass and causes dust, lint, etc. to cling to the glass surface. Also, initial paint curing can deposit a slight film on the glass. In some geographic areas, a white film may be deposited on the glass due to combustion of some of the constituents of natural gas. It is therefore recommended that initially the glass be cleaned two or three times with non-abrasive common

household cleansers and warm water. After that, the glass should be cleaned two or three times a season depending on the amount that the fireplace is used.

To remove, simply unlatch the top and bottom door latches and carefully pull door forward. Use of gloves recommended.



Do not clean when the glass is hot.

Do not strike or abuse glass.

Do not place glass door on edge after removal.

Louvre Installation

The fireplace is shipped without the louvre assemblies installed. Various styles and finishes are available as options. Contact your nearest Temco dealer/distributor for information on the Louvre Kits available.

Model DV1000:

1. To install the upper louvre assembly, the first louvre blade from the top on each louvre assembly will hook onto the top tabs of the louvre brackets. (Fig. 30)
2. Once the first louvre blade has engaged the top tab of the end brackets, swing the bottom of the louvre assembly inward so the louvre hangs flush with the fireplace face.

Models DV1200 and DV1400:

1. To install the upper louvre assembly, the second louvre blade from the top on each louvre assembly will hook onto the top tabs of the louvre bracket. (Fig. 30)
2. Once the second louvre blade has engaged the top tab of the end brackets, swing the bottom of the louvre assembly inward so the louvre hangs flush with the fireplace face.

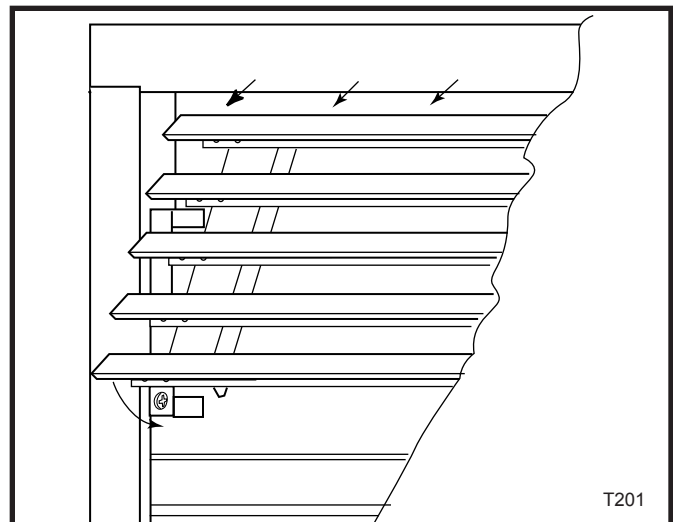

Fig. 30 Hook first or second louvre blade (depending on fireplace model) onto top tabs of louvre brackets.

After completing Steps 1 and 2, the louvre assembly should look like the illustration shown in Figure 31.

Models DV1000, DV1200 and DV1400: To install the bottom louvre assembly, hook the top louvre blade ends over the top hang tabs located at the left and right ends of the panel opening.

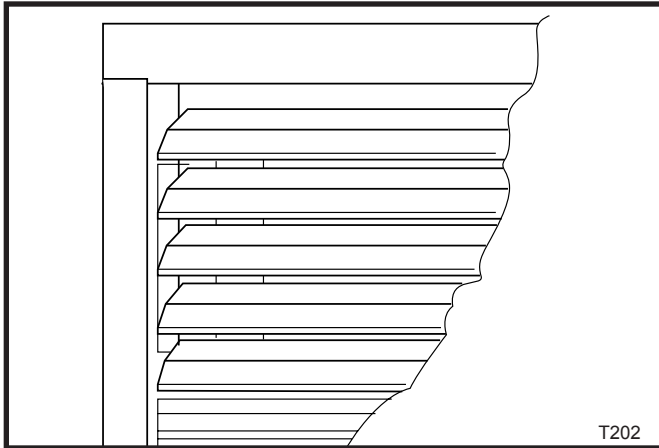

Fig. 31 Louvre in place.

Log Installation

Attention: Glass door should be removed when installing logset and prior to lighting the unit.

1. Remove glass door (Refer to "Glass Door Removal Procedure")
2. Remove logs from carton and inspect. Refer to Figures 32 and 33.
3. Rear log should be installed onto rear log supports. Match up slots on rear of log with the vertical log bracket tabs. Push log back as far as it will go.
4. The center log should be placed on the center log supports, slots aligned with tabs, and log placed rearward.
5. Top twigs can then be placed in their designated positions provided with pins on back logs, and grooves on the center log. The two outside twigs provided on the DV1400 models rest on top of the ends of the grate. They are located and supported by the wire formed brackets extending up from the firebox base. (Fig. 35)
6. Place rock wool loosely along top edge of ember retainer along entire length of ported area of front burner. Use individual pieces of rock wool about the size of a quarter. Rock wool should be fluffed up and not compressed. Rock wool must be held up by ember retainer tray. Do not allow embers to fall on burner and cover burner ports.
7. Ember tray ends beyond burner port area and area in front of grate may be covered with lava rock to suit individual appearance preferences.
8. Purge lines and test pilot operation.

9. Replace glass door. The door must be installed before operating the fireplace. (Refer to Page 24)
10. Flame should not impinge (touch) on logs.



WARNING: Do not place rock wool, lava rock or any other materials on the burner. Use only certified material supplied with this fireplace. Using uncertified materials will void the warranty.

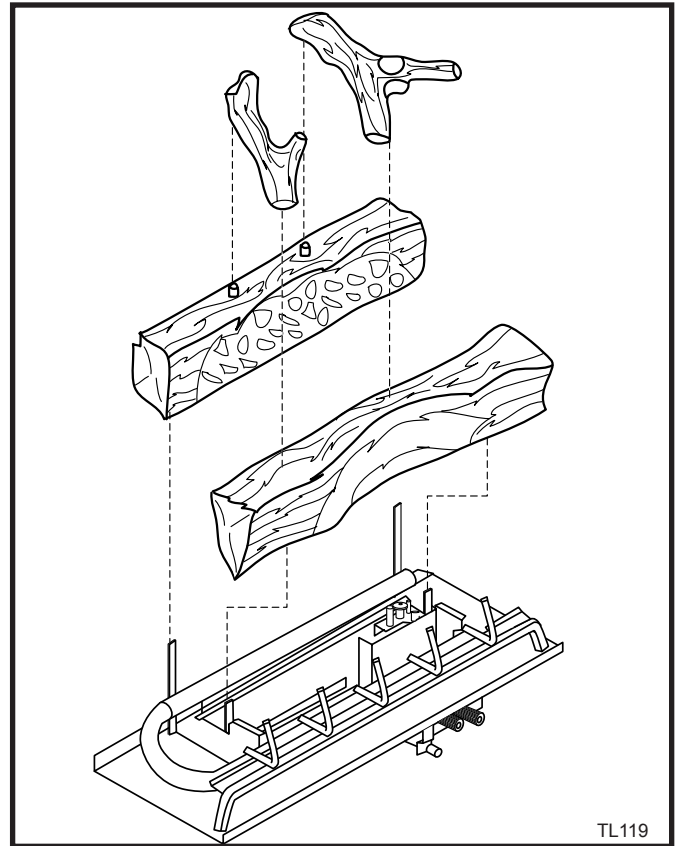

Fig. 32 Correct log placement for DV1000 and DV1200.



Fig. 33 Correct log placement for DV1400.

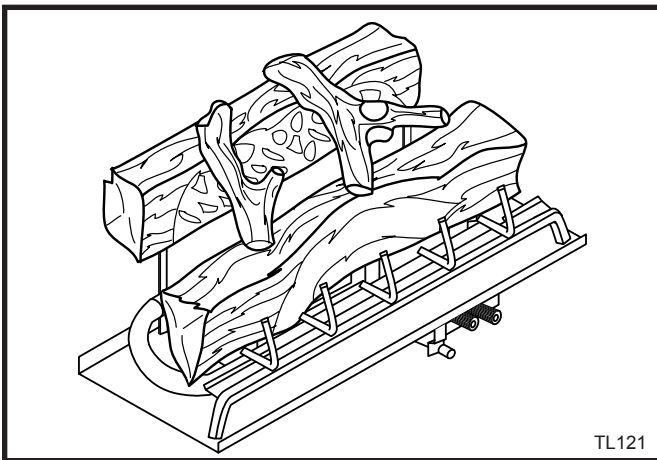

Fig. 34 DV1000 and DV1200 logs in final position.

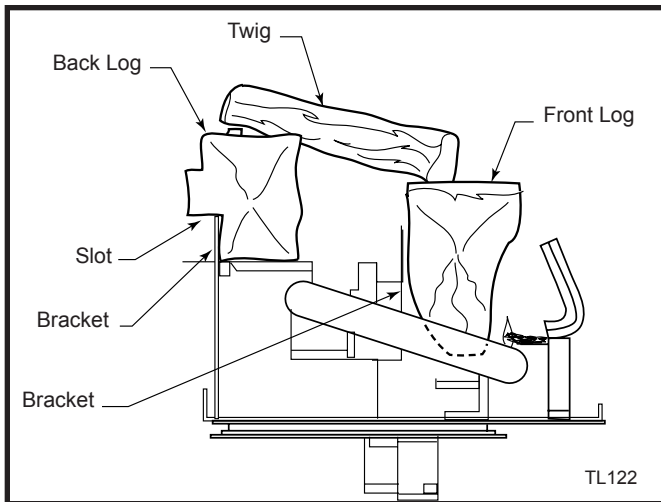

Fig. 35 Side view of logset. (NOTE: The side logs for the DV1400 are not shown.)

Thermostatic Fan Kit - Optional

(Part # GDVTFK)

For installation of the optional fan, please refer to the instructions included in the fan kit.

Electrical Services

Optional fan kits are equipped with a 120V, 60Hz blower, less than 12 amps.

If electrical supply 120V is being roughed in to provide for future installation of an optional blower kit, an approved surface mount, steel electrical box, cover and strain relief bushing must be installed in the fireplace (supplied by others).

NOTE: All electric connections are to be made in accordance with CSA Standard C22.1 - Canadian Electrical Code part 1 or with the National Electrical Code, ANSI/NFPA 70 (latest addition) and/or in accordance with local codes.

Speed Control Switch

1. The blower combination on/off switch and electronic speed control is supplied loose to allow mounting in a conveniently located wall mounted electrical box.
2. Wire speed control into black (hot) side of 120V, 60Hz line as shown in blower wiring diagram.

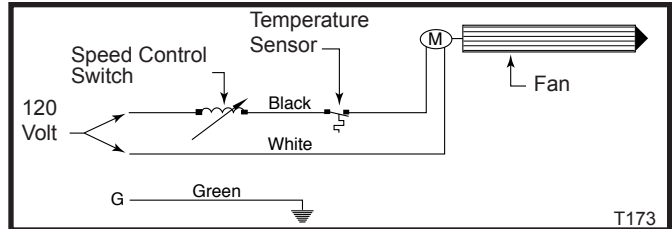

Fig. 36 Fan wiring diagram.



CAUTION: Should this fan require servicing, the power supply must be disconnected.

Millivolt System



CAUTION: At installation and/or after any service work or repairs glass door must be removed before proceeding to lighting instructions.



CAUTION: At installation and/or after any service work or repairs glass door must be removed before proceeding to lighting instructions.

Burner On/Off Control

All models may be used with an optional wall switch that turns the main burner on or off. Optional millivolt thermostats (GFPMT) and remote control may be substituted for the wall switch (For installation of these options, detail instructions are provided with optional kits).

CAUTION: If the remote receiver is located in the gas control area (under the firebox), clearance should be below the firebox at least 2" (51 mm) to avoid high temperatures (receiver should not be exposed to temperatures exceeding 130°F).

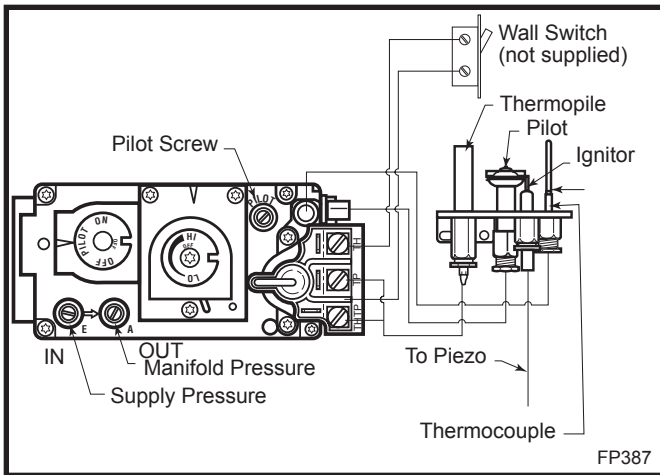

Fig. 37 Pilot and valve wiring.

Recommended Maximum Lead Length (Double Wire) When Using Wall Switch or Thermostat	
Wire Size	Max. Length
14 ga.	50' (15.2 m)
16 ga.	32' (9.8 m)
18 ga.	20' (6 m)
20 ga.	15' (4.6 m)
22 ga.	10' (3 m)

NOTE: All Models are supplied with 15' (4.6 m) of double wire for use with a wall switch.



CAUTION: Do not wire 120V power to millivolt switches or thermostats.

Managing Heat Output

The heat output from the appliance may be controlled by adjusting the main gas valve. Reference lighting instructions on Page 28 and chart on Page 34 showing inputs at all the settings.

The main gas valve may be adjusted anywhere between high and low to give the desired combination of flame aesthetics and heat output.

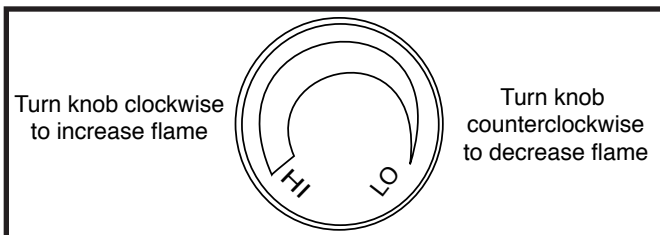

Fig. 38 Flame adjustment knob.

Fan Operation

The fan operates automatically - turn the knob on the speed control to adjust to the desired speed. The fan will turn on as the fireplace comes up to operating temperature. After the unit has been turned off and the unit cooled to below a useful heat output range the fan will shut off automatically.

Flame Characteristics

It is important to periodically perform a visual check of the pilot and burner flames. Compare them to Figure 39.

If the flame patterns appear abnormal, contact a qualified service provider for service and adjustment.

Pilot Burner Adjustment

1. Adjust pilot screw to provide proper sized flame.
2. Leak test.

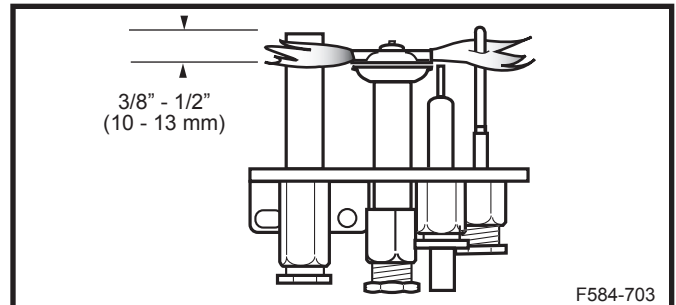

Fig. 39 Correct flame appearance.

Lighting And Operating Instructions

FOR YOUR SAFETY READ BEFORE LIGHTING

WARNING: If you do not follow these instructions exactly, a fire or explosion may result causing property damage, personal injury or loss of life.

- A. This appliance has a pilot which must be lit manually. When lighting the pilot follow these instructions exactly.
- B. BEFORE LIGHTING smell all around the heater area for gas. Be sure to smell next to the floor because some gas is heavier than air and will settle on the floor.

WHAT TO DO IF YOU SMELL GAS

- Do not try to light any appliance
- Do not touch any electric switch
- Do not use any phone in your building
- Immediately call your gas supplier from a neighbor's phone. Follow the gas supplier's

instructions.

- If you cannot reach your gas supplier, call the Fire Department
- C. Use only your hand to push in or turn the gas control knob. Never use tools. If the knob will not push in or turn by hand, do not try to repair it, call a qualified service technician. Force or attempted repair may result in a fire or explosion.
- D. Do not use this appliance if any part has been under water. Immediately call a qualified service technician to inspect the heater and to replace any part of the control system and any gas control which has been under water.

Lighting Instructions

1. **STOP!** Read the "For Your Safety" information first and locate the control panel before lighting.
2. Turn off all electrical power to the fireplace.
3. For MN/MP/TN/TP appliances ONLY, go on to Step 4. For other appliances turn the On/Off switch to "OFF" position or set thermostat to lowest level.
4. Open control access panel.
5. Push in gas control knob slightly and turn clockwise  to "OFF".



Euro SIT

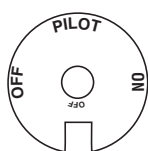

SIT NOVA

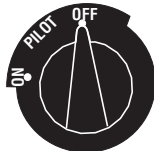

Honeywell

6. Wait five (5) Minutes to clear out any gas. Then smell for gas, including near the floor. If you smell gas, STOP! Follow "B" in the safety information above. If you do not smell gas, go to the next step.
7. Remove glass door before lighting pilot. (Refer to Glass Frame Removal Section)
8. Visibly locate pilot by the main burner.

9. Turn knob on gas control counterclockwise  to "PILOT".
10. Push the control knob all the way in and hold. Immediately light the pilot by repeatedly depressing the piezo spark ignitor until a flame appears. Continue to hold the control knob in for about one (1) minute after the pilot is lit. Release knob and it will pop back up. Pilot should remain lit. If it goes out, repeat steps 5 through 8.

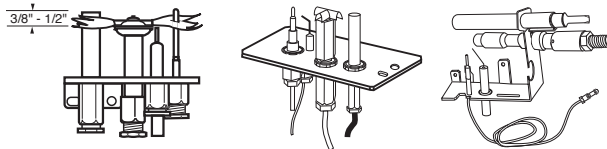

- If knob does not pop up when released, stop and immediately call your service technician or gas supplier.
 - If after several tries, the pilot will not stay lit, turn the gas control knob to "OFF" and call your service technician or gas supplier.
11. Replace glass door.
 12. Turn gas control knob to "ON" position.
 13. For RN/RP appliances turn the On/Off switch to "ON" position or set thermostat to desired setting.
 14. Turn on all electrical power to the fireplace.

To Turn Off Gas To Heater

1. Turn the On/Off switch to Off position or set the thermostat to lowest setting.
2. Turn off all electric power to the fireplace if service is to be performed.
3. Open control access panel.
4. Push in gas control knob slightly and turn clockwise  to "OFF". Do not force.
5. Close control access panel.

Troubleshooting

SIT Millivolt Valve

NOTE: Before troubleshooting the gas control system, be sure external shut off is in the "ON" position.



WARNING: Before doing any gas control service work, remove glass front!

Table 1

Valve Type	Main Operator		Safety Magnet	
NOVA MV Plus	Minimum Voltage	145mV	Hold-in Current	Less than 285mA
	Coil Resistance	2.25Ω ± 0.5Ω	Drop-out Current Coil Resistance	Greater than 125mA 0.108Ω ± 0.003Ω

System Checks

Problem	Possible Cause	Solution
Pilot will not light.	Air in gas lines.	Bleed all air from gas lines.
	Wrong inlet pressure.	With the main burner functioning, adjust the inlet pressure regulator to supply gas to the appliance within the design parameters of the appliance manufacturer. (Typically 7"NG, 11"LPG).
	Defective spark electrode.	Replace piezo wire if insulation is cracked or the tip is corroded. Verify that the spark gap between the pilot and the electrode is correct.
	Defective piezo wire.	Replace piezo wire if insulation is damaged, or the wire is broken or corroded.
	Safety interlock function engaged.	Allow thermocouple to cool until the mv drops below the hold-in requirements of the safety magnet, (30 seconds or less). Re-light pilot.
Pilot will not hold.	Wrong inlet pressure.	With the main burner functioning, adjust the inlet pressure regulator to supply gas to the appliance within design parameters of the appliance manufacturer. (Typically 7"NG, 11"LPG)
	Pilot adjustment screw not properly adjusted.	After the pilot has been lit for approximately three minutes, and only the thermo-generator wire connected to the main operator head, measure the voltage across TPTH and TP. This open circuit voltage should be between 500mv and 750mv. Tune the pilot adjustment screw until the mv reading falls within these parameters. (Counter-clockwise increases mv reading, clockwise decreases).
	Thermocouple or thermo-generator not properly inserted into the pilot housing	Make certain that the thermocouple and thermo-generator are fully inserted and tightened into their receptacles in the pilot head. The thermocouple should be threaded into the valve hand-tight, plus 1/4 turn with wrench.
	Thermocouple or thermo-generator has film build-up on tip.	With the thermocouple and thermo-generator tips cool, clean the upper 3/8" with a very fine emery cloth.
	Electrical resistance too high.	Using a very fine emery cloth, clean thermo-generator and thermocouple connections at valve. Tighten thermocouple into valve hand-tight, plus 1/4 turn with a wrench.

System Checks (continued)

Problem	Possible Cause	Solution
	Defective thermocouple. (mv Plus systems)	Verify that thermocouple is not kinked or damaged. Check open circuit voltage of thermocouple. Voltage should be between 18mv and 28mv. If voltage is less than 14mv, replace thermocouple.
	Defective thermo-generator. (Millivolt system)	After the pilot has been lit for approximately three minutes, and only the thermo-generator wire connected to the main operator head, measure the voltage across TPTH and TP. This open circuit voltage should be between 500mv and 750mv. Tune the pilot adjustment screw until the mv reading falls within these parameters. (Counter-clockwise increases mv reading, clockwise decreases)
	Defective safety magnet. (mv Plus systems)	Verify operation of safety magnet in the following manner. (A) Depress and hold pilot button. (B) Verify open-circuit thermocouple voltage as described in previous step. (C) Reconnect thermocouple to valve. (D) Measure the Millivoltage between the solder button on the base of the safety magnet, and the valve body. If the mv reading is above 6mv for vented appliances, or 8.5 mv for un-vented appliances, and the safety magnet does not hold, replace the valve. (E) If closed circuit mv reading is the same as the open circuit reading, the coil is electrically open. Replace the valve.
	Defective Safety Magnet (Millivolt system)	Verify operation of safety magnet in the following manner. (A) Remove all wires from the terminals of the main operator. (B) Measure the electrical voltage between the terminals TPTH and TP. If the voltage is above 110mV and the safety magnet does not hold, replace the valve.
	Pilot orifice blocked.	Replace orifice with a new orifice of the exact size and type.
Pilot drops out.	Wrong pilot orifice.	Replace the orifice with a new orifice supplied specifically for the appliance and gas type in question.
No gas to main burner	Low gas pressure to appliance.	With the main burner functioning, adjust the inlet pressure regulator to supply gas to the appliance within the design parameters of the appliance manufacturer. (Typically 7"NG, 11"LPG).
	Pilot not lit.	Light pilot and wait for thermo-generator to heat up sufficiently to power the main operator. If pilot fails to light, or hold, refer to above sections.
	Control knob not in ON position.	Rotate OFF/PILOT/ON control knob to the ON position.
Thermostat/wall switch will not cycle main burner.	Thermostat not in ON position.	Turn thermostat ON, and adjust temperature control to call for heat.

System Checks (continued)

Problem	Possible Cause	Solution
	Thermo-generator output voltage not within design parameters.	After the pilot has been lit for approximately three minutes, and only the thermo-generator wire connected to the main operator head, measure the voltage across TPTH and TP. This open circuit voltage should be between 500mv and 750mv. Tune the pilot adjustment screw until the mv reading falls within these parameters. (Counterclockwise increases mv reading, clockwise decreases) If unable to meet minimum requirements, replace thermo-generator.
	Defective thermostat or thermostat wiring	(A) With the pilot adjusted properly, (After the pilot has been lit for approximately three minutes, and only the thermo-generator wire connected to the main operator head, measure the voltage across TPTH and TP. This open circuit voltage should be between 500mv and 750mv. Tune the pilot adjustment screw until the mv reading falls within these parameters. Counterclockwise increases mv reading, clockwise decreases), place a jumper wire between TPTH and TH. Take a mv reading across the TPTH and TP terminals on the valve. This closed circuit voltage should not fall below 300mv. Record reading. (B) Remove jumper wire from the TPTH and TH connections, and reconnect the thermostat wires to the same terminals. Take the closed circuit voltage as described in the previous step. If the mv reading drops below 150mv, excessive resistance exists in the thermostat circuit, and must be isolated and eliminated.
Thermostat/wall switch will not cycle main burner.	Defective wall switch.	Repeat the above troubleshooting items covered under "Defective thermostat or thermostat wiring", except substitute the words "wall switch" where the word "thermostat" appears in the instructions.
	Excessive wire resistance.	Make certain that all mv connections are made using wire of the proper size. (Reference Page 26).
	Valve wired wrong.	Thermo-generator leads must be connected to the TPTH and TP connections of the main operator. Thermostat wires must be connected to the TPTH , and TH terminals of the valve.
Main burner lights in the PILOT position.	Main operator coil defective.	Verify electrical resistance of main operator coil in the following manner. (A) Remove all wires from operator head. With an Ohm meter, measure electrical resistance between TP and TH terminals. If the resistance does not fall within specification, replace valve. (See table 1).
	Debris on seat of main valve.	Replace valve.
	Main seat blown out as a result of exposing LPG gas valve to unregulated line pressure in excess of 15 PSI.	Replace valve.

Maintenance

Once installed, the unit should be operated at least three (3) times to ensure that all is in working order.
NOTE: Manufacturing oils will smoke during initial firing of appliance. Open windows for ventilation.

Unit Adjustment

Before leaving, the installer should make the following checks:

Btu Input/Gas Pressure

The fireplace input is marked on the Rating Plate. The gas inlet pressure specified in Table 1 is the pressure where the field-installed gas line connects to the gas control. This is measured at the inlet test port on the gas valve in the appliance. Ensure that pressure is as shown in Table 1.

The manifold pressure is controlled by a regulator built into the gas control and should be checked at the pressure outlet test port located on the body of the gas valve.

The pressure should be checked with the appliance burning on high (highest setting) and all other gas appliances turned on. One must then read the manometer and if pressures are not as specified in Table 1, then the inlet pressure must be adjusted.

The appliance and its individual shut-off valve must be disconnected from the gas supply piping system during any pressure testing of the system at test pressures in excess of 1/2 psig (3.5 KPa).

Manifold pressure can be measured by using a 5/16" I.D. hose or tubing. Using a small blade screwdriver, back out the pressure screw for one full turn. Next, slip the tubing over the pressure tap extension to check the pressure with a manometer. Inlet and outlet pressure taps are located on the front (lower left side) of the valve body.

1. Tap on the left side of the valve will give inlet supply pressure.
2. Tap on the right side of the valve will give manifold pressure.

Pressure ranges are as listed below:

Table 1

	Gas Supply Pressure (inches w.c.)		
	Minimum	Normal	Maximum
Natural Gas	4.5"	7.0"	14.0"
LP (Propane)	10.8"	11.0"	14.0"
	Manifold Pressure (inches w.c.)		
	Normal (HI)	Normal (Low)	
Natural Gas	3.5"	1.6"	
LP (Propane)	10.0"	6.3"	

High Altitude

When installing this fireplace at an elevation between 0 and 2000 feet (0 - 610m) in the USA and 0 and 4500 feet (0 - 1370m) in Canada the input rating does not need to be reduced.

When installing this fireplace at an elevation above 2,000 feet (in the United States), it may be necessary to decrease the input rating by changing the existing burner orifice to a smaller size. Input should be reduced four percent (4%) for each 1,000 feet above sea level, unless the heating value of the gas has been reduced, in which case this general rule will not apply. To identify the proper orifice size, check with the local gas utility.

When installing this fireplace at an elevation above 4,500 feet (in Canada), check with local authorities. Consult your local gas utility for assistance in determining the proper orifice for your location.

Main Burner/Pilot

The pilot flame size is factory set. The pilot flame should be at least 1½" (38 mm) long. The flame should be impinging on the pilot generator. Pilot size can be adjusted through the pilot adjust screw. If the pilot flame is too small and can not be adjusted through the pilot adjust screw then there is the possibility of dirt in the pilot orifice in which case the pilot orifice should be cleaned or replaced.

The main burner should be allowed to operate for 15 to 20 minutes before making any adjustment to the burner. The air shutter on the right front of the main burner should be adjusted so that there are no orange/red flames with dark sooty looking tips. A luminous yellow flame with blue base is what is acceptable.

For burner air shutter settings see Air Shutter Settings chart. (Page 34)

If there is too much primary air then the flame will be very blue with yellow tips and smaller flame height. If there is too little primary air then the flame will be yellow with orange/red tips on the back flames with dark sooty elongated tips. In this condition the glass and logs could show signs of soot accumulation within 10 to 20 minutes.

Maintenance

Motor and Blower for Fan Kit (optional)

This motor has been factory oiled and under normal operating conditions should not require oiling.



WARNING: Ensure the power is turned off to the fireplace before servicing.

Cleaning

This unit should be cleaned and serviced by a Qualified Gas Technician at least annually. More frequent cleaning may be necessary if pet hair accumulates, dust and lint are present, or if the unit is located in a high traffic area. A Qualified Agency is defined in the Gas Code.

Cleaning should include burner tubes, orifice/injectors (refer to section B.3 National Fuel Gas Code), logs, ceramic base, and pilot assembly. It is recommended that the sediment trap in the gas line be emptied and cleaned at this time. (Refer to Section 3.7.2 National Fuel Gas Code)

Burner, Pilot, Firebox and Logs



CAUTION: Before cleaning or moving logs or other parts of the unit, be sure to read the section on important safeguards.

Cleaning should be done before the logs are used each year and after long periods of non-use. All cleaning should be carried out when the appliance is cold.

Cleaning will be required under normal use. Dusting the front grate or the control knob panel may be required occasionally. Do not use any cleaning fluids to clean the logs or any other part of the appliance.

If the flames show any unusual shapes or behavior, or if the burners fail to ignite properly, then the burner holes may require cleaning. If this occurs, contact your nearest dealer to get the appliance serviced.

Alternatively, the appliance can be cleaned by removing all the logs. Handle the logs gently so as not to damage them. Always lift each log by holding it carefully at each end.

After the logs are removed allowing access to the burner area, use a vacuum cleaner to carefully remove dust and loose particles from the base, logs and from around the burners. Gloves are recommended to prevent the ceramic fibers that compose the logs from pricking your skin. If the skin is pricked, wash gently with soap and water. Use extreme caution in cleaning around the pilot. The pilot should not be moved or altered from the original factory setting (Pilot to burner preset location). The burner should be placed back into its original locked and secure position after cleaning and servicing (proper location of burners are critical). **NOTE:** All replacements and repairs should be performed by a qualified technician (contact your nearest dealer). After cleaning and/or repairs, follow instructions for positioning of logs as illustrated on Page 25.

Glass

It will be necessary to clean the glass periodically. During startup it is normal for condensation to form on the glass and cause dirt, lint, etc., to adhere to the inner surface of the glass. There also will be a film deposited on the glass during the initial use of the fireplace due to initial curing of the paint. It is recommended that the glass be cleaned with a non-abrasive household cleaner and warm water. Be sure to rinse and dry the glass well as not to leave any marks. It will be necessary to clean the glass up to 3 times a season depending on use of the fireplace.

Louvers/Trim/Surround

All gold, platinum, black anodized and painted surfaces should only be wiped off with a soft non-abrasive damp cloth (a mild dish soap can be used if necessary).

DO NOT use brass or other metal polishes, glass cleaners or any abrasive cleaners as this will mark and damage brass or painted surfaces.

Normal and High Direct Vent Units - Inputs - Orifice Size - Altitude				
Model	BTU/Hr Min. Input	BTU/Hr Max. Input	Manifold Pressure @ Max.	Orifice 0 - 2000ft. Altitude in USA Orifice 0-4500ft Altitude in Canada
DV1000N	12,500	18,500	3.5" w.c.	#46 DMS
DV1000P	12,500	18,500	10.0" w.c.	#56 DMS
DV1200N	13,000	20,000	3.5" w.c.	#45 DMS
DV1200P	13,000	20,000	10.0" w.c.	#55 DMS
DV1400N	15,000	22,000	3.5" w.c.	#43 DMS
DV1400P	15,000	22,000	10.0" w.c.	#54 DMS

Conversion Kits		
Model	Change Natural to Propane	Change Propane to Natural
DV1000N	B32ACLP	--
DV1000P	--	B32ACNG
DV1200N	B36ACLP	--
DV1200P	--	B32ACNG
DV1400N	B42ACLP	--
DV1400P	--	B42ACNG

IMPORTANT: Always check for gas leaks with a soap and water solution. Do not use open flame for leak testing.

Air Shutter Settings		
Model	Opening "A" (inches)	Opening "A" (mm)
DV1000N	1/8"	3.2 mm
DV1000P	1/8"	3.2 mm
DV1200N	1/8"	3.2 mm
DV1200P	3/16"	4.7mm
DV1400N	1/8"	3.2mm
DV1400P	1/4"	6.3mm

NOTE: These are minimum settings. Air shutter openings may be increased to prevent flame sooting.

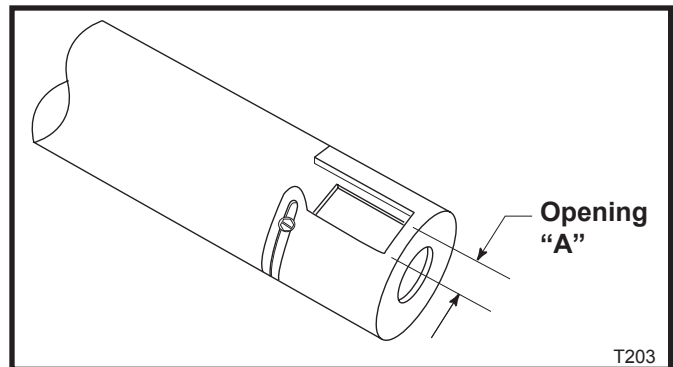

Fig. 40 Air shutter opening.

DV1000 / DV1200 / DV1400 Replacement Parts

Ref.	Description	DV1000	DV1200	DV1400
1.	Burner	75470	75470	75470
2.	Gasket Tape 5/8" Wide	75449	75448	75447
3.	Gas Valve LP (SIT)	76448	76448	76448
4.	Gas Valve NG (SIT)	76449	76449	76449
5.	Glass Door Assembly	75374	75373	75372
6.	Log Set	77282	77282	76761
6a.	Log, Front	76895	76895	76893
6b.	Log, Back	75317	75317	75317
6c.	Log, Right Twig	75318	75318	75318
6d.	Log, Left Twig	75319	75319	75319
6e.	Log, Twig (Top)	--	--	76398
7a.	LP/Propane Burner Orifice	PCOA070H21	PCOA070H19	76759
7b.	Natural Gas Burner Orifice	PCOA070H08	PCOA070H07	PCOA070H05
8.	Piezo Ignitor	65180	65180	65180
9.	Pilot, Natural (SIT)	76261	76261	76261
10a.	Pilot, Orifice, Natural	76262	76262	76262
10b.	Pilot, Orifice, LP	76263	76263	76263
11a.	Rep. Reg. Assembly LP Hi/Lo 82979	PCOB068	PCOB068	PCOB068
11b.	Rep. Reg. Assembly NG Hi/Lo 86354	PCOB069	PCOB069	PCOB069
12.	Thermocouple	PCOA075	PCOA075	PCOA075
13.	Thermopile (Pilot Generator)	PCOB021	PCOB021	PCOB021
14.	Grate Assembly	76485	76485	76760
15.	Rock Wool (Bag)	76675	76675	76675
16.	Black Anodized Aluminum Grille Panels	GBL1000	GBL5200	GBL7400
17.	Gold Colored Anodized Aluminum Grille Panels	GPB1000	GPB5200	GPB7400
18.	Platinum Colored Anodized Aluminum Grille Panels	PGT1000	GPT5200	GPT7400
19.	Black Painted Steel Grille Panels	GST1000	GST5200	GST74000

Always include correct name, part number, valve manufacturer, model number and serial number of the appliance when ordering service parts.

If you desire to communicate with the factory, write to Customer Service at:

CFM Specialty Home Products
2695 Meadowvale Blvd.
Mississauga, Ontario
Canada L5N 8A3

Servicing

Repair and replacement work should only be done by a qualified service person.

Always shut off the gas supply and make sure the appliance is cool before beginning any service operation.

Always check for gas leaks after servicing.

Limited Warranty

TEMCO Fireplace Products Direct Vent Gas Fireplaces

This warranty is limited to **TEMCO Fireplace Products** Direct Vent Gas Fireplaces (henceforth, Product) manufactured by **CFM Specialty Home Products** (henceforth, CFM).

ONE YEAR WARRANTY

CFM warrants all components of the Product to be free of defects in materials and workmanship for a period of one year from the date of installation, with the exception of the warranty on logs and ember base. If, by the sole determination of **CFM**, any component covered under this warranty is found to be defective, **CFM** will, at its option, repair or replace the defective component at no charge and will pay labor cost incurred as specified in the current **CFM** Labor Allowance Schedule, 71313. If **CFM** determines replacement or repair is not economically practical, **CFM** will, at its option, refund the purchase price of the Product. Date of installation and purchase price must be verified by acceptable proof of purchase.

This warranty covers only parts and labor as provided above. In no case shall **CFM** be responsible for materials, components or construction which are not manufactured or supplied by **CFM**, or the labor necessary to install, repair or remove such materials, components or construction.

NOTE: If allegedly defective components need to be returned by CFM in connection with the above warranties, freight or postage charges must be prepaid.

QUALIFICATIONS

For the above warranties to apply:

The Product must be installed by a qualified installer; strictly in accordance with CFM installation instructions, and in compliance with local codes and ordinances. The logs must be placed strictly in accordance with the arrangement described in the installation instructions.

The Product must be operated and maintained according to the instructions furnished. **Alteration of the Product in any way is prohibited and voids any and all warranties. Removal of the data plate alters the Product and voids the warranty.**

The installer must have completed the installation and Startup Checklist, a copy of which must be submitted along with proof of purchase, to obtain prior approval for warranty repair or replacement and to affect a warranty claim. The Checklist is found on Pages 20 and 21 of this manual.

The limited warranty applies only to the original owner of the Product or the original owner of the dwelling in which the Product was installed. Use of any parts other than genuine factory provided replacement parts shall void this warranty.

Limitations

CFM is not responsible for any incidental or consequential damages caused by possible defects in the Product. The duration of any implied warranty with respect to the Product is limited to the duration of the foregoing warranties.

CFM is not responsible for any warranty repair (material or labor) for defects created by improper field conversions.

Some states and provinces do not allow exclusion of incidental or consequential damages or limits on the duration of implied warranties, so these limitations may not apply to you.

Warranty Fulfillment

Claims require specific agreement and consent from CFM Technical Services prior to performing any warranty repair or replacement. CFM reserves the right to investigate any and all warranty claims. The appliance must not be removed prior to such investigation other than on direction from **CFM**.

Please provide the following information when communicating with **CFM** Technical Services, its Dealers or Distributors regarding service under this warranty.

CFM reserves the right to decide on the method of settlement (if any). This limited warranty is given in lieu of any other expressed or implied warranty, and supercedes all other **CFM** Product warranties.

Model Number: _____

Serial Number: _____

Date of Installation: ____/____/____

Purchased From: _____

TEMCO FIREPLACE PRODUCTS DIRECT VENT FIREPLACES INSTALLATION AND STARTUP CHECKLIST

Customer Copy

NOTE: TEMCO Fireplace Products gas logs and fireplaces require installation by a qualified gas appliance installer. A copy of this checklist must be submitted, along with proof of purchase, when applying to Technical Services for prior written approval of warranty repair or replacement.

- Read and understand installation instructions before attempting installation.

Verify CORRECT FUEL TYPE

- Check carton model number.
- Check fireplace label. Models ending in N are for natural gas; those ending in P are for propane (LP gas).

WARNING: Using the incorrect fuel can create a serious fire hazard and will void the warranties. Install in accordance with local and/or national codes and ordinances. Follow the TEMCO installation instructions.

- Supply service shutoff valve upstream of gas fireplace.
- Gas line size adequate for input rating (BTU's per hour) of fireplace, per National Fuel Gas Code (NFPA54) in the case of USA installations or Installation Code CAN 1-149 in the case of Canadian installations.

Make following checks:

- Gas line integrity at supply line connection.
- Glass front panel position.
- Correct gas pressure. Inlet Pressure _____(inches w.c.) Manifold Pressure _____(inchesw.c.)
- Piezo ignitor function (millivolt control models only).
- Pilot ignition.
- Main burner ignition.
- Proper flame pattern and color.
- Positioning of logs (in accordance with instructions).
- Clearances to combustibles (vent, framing, mantels, etc.).
- Vent system in compliance with instructions. All joints and connections sealed.
- Wall switch operation. Do not connect millivolt wiring, wall switch or valve to 120v line voltage unless units is specifically DSI equipped.
- Demonstrated proper operating procedure to homeowner.
- Explained the need for proper cleaning and maintenance.
- Check all fittings and connections for gas leaks, correct if necessary.

Please sign below that checklist has been completed and understood. DATE INSTALLED ____/____/____

Installer

Phone

Consumer

Phone

TEMCO FIREPLACE PRODUCTS DIRECT VENT FIREPLACES INSTALLATION AND STARTUP CHECKLIST

Installer's Copy

NOTE: TEMCO Fireplace Products gas logs and fireplaces require installation by a qualified gas appliance installer. A copy of this checklist must be submitted, along with proof of purchase, when applying to Technical Services for prior written approval of warranty repair or replacement.

- Read and understand installation instructions before installing.

Verify CORRECT FUEL TYPE

- Check carton model number.
- Check fireplace label. Models ending in N are for natural gas; those ending in P are for propane (LP gas).

WARNING: Using the incorrect fuel can create a serious fire hazard and will void the warranties. Install in accordance with local and/or national codes and ordinances. Follow the TEMCO installation instructions.

- Supply service shutoff valve upstream of gas fireplace.
- Gas line size adequate for input rating (BTU's per hour) of fireplace, per National Fuel Gas Code (NFPA54) in the case of USA installations or Installation Code CAN 1-149 in the case of Canadian installations.

Make following checks:

- Gas line integrity at supply line connection.
- Glass front panel position.
- Correct gas pressure. Inlet Pressure _____(inches WC) Manifold Pressure _____(inchesWC)
- Piezo ignitor function (millivolt control models only).
- Pilot ignition.
- Main burner ignition.
- Proper flame pattern and color.
- Positioning of logs (in accordance with instructions).
- Clearances to combustibles (vent, framing, mantels, etc.).
- Vent system in compliance with instructions. All joints and connections sealed.
- Wall switch operation. Do not connect millivolt wiring, wall switch or valve to 120v line voltage unless units is specifically DSI equipped.
- Demonstrated proper operating procedure to homeowner.
- Explained the need for proper cleaning and maintenance.
- Check all fittings and connections for gas leaks, correct if necessary.

Please sign below that checklist has been completed and understood. DATE INSTALLED ___/___/___

Installer

Phone

Consumer

Phone

Customer Copy

Model # _____ Serial # _____

I certify that I have followed all codes and regulations and adhered to the TEMCO Fireplace Products installation instructions. I have completed the proper installation and startup checklist.

Installer's Signature

Purchaser _____
Address _____

Phone _____
Retailer _____
Address _____

Phone _____
Date of Purchase _____

Print Installer's Name

WARRANTY REGISTRATION

Please answer the following questions (Check Box):

1. Type of Home Single Family Duplex Apt.
 Mobile Home Cabin/Vacation
2. Installed in(Room) Living Family Great Rec Bedroom Other
3. Other Choices Considered Vented Decorative Gas Log/Fireplace Woodburning Fireplace Gas Insert Woodburning Insert Direct-Vent Gas Fireplace/Logs
4. Why did you choose Direct Vent? (Rank in order of importance: 1-6)
___ Appearance ___ Location Flexibility
___ Builder Decided ___ Other

Please cut along dotted line

To register your warranty, please provide the information indicated on this form and mail it to:

TEMCO Fireplace Products
Attn: Warranty Registration
2695 Meadowvale Blvd.
Mississauga, Ontario Canada L5N 8A3

Model # _____ Serial # _____

I certify that I have followed all codes and regulations and adhered to the TEMCO installation instructions. I have completed the proper installation and startup checklist.

Installer's Signature

Purchaser _____
Address _____

Phone _____
Retailer _____
Address _____

Phone _____
Date of Purchase _____

Print Installer's Name

WARRANTY REGISTRATION

Please answer the following questions (Check Box):

1. Type of Home Single Family Duplex Apt.
 Mobile Home Cabin/Vacation
2. Installed in(Room) Living Family Great Rec Bedroom Other
3. Other Choices Considered Vented Decorative Gas Log/Fireplace Woodburning Fireplace Gas Insert Woodburning Insert Direct-Vent Gas Fireplace/Logs
4. Why did you choose Vent-free? (Rank in order of importance: 1-6)
___ Appearance ___ Location Flexibility
___ Builder Decided ___ Other

NATIONAL
FIREPLACE
INSTITUTE



CERTIFIED
www.nficertified.org

We recommend that our gas hearth products be installed and serviced by professionals who are certified in the U.S. by the National Fireplace Institute® (NFI) as NFI Gas Specialists.

CFM Corporation

2695 Meadowvale Blvd. • Mississauga, Ontario, Canada L5N 8A3
800-668-5323 • www.cfmcorp.com