

LIFEBREATH[®]

CLEAN AIR FURNACE

“ELECTRIC” CLEAN AIR FURNACE MANUAL

Introduction

Congratulations on your selection of the Lifebreath Clean Air Furnace. This is a very advanced unit that combines an electric furnace with the tremendous health benefits of year-round fresh air ventilation in every room of your house.

With the addition of Lifebreath T.F.P. Air Cleaner (optional) you will have the ultimate in comfort and healthy indoor air quality. (See back cover of this manual)

Once it is correctly installed, safety will never be an issue with your Lifebreath furnace. No flames, fumes or flue gases to be concerned about.

This Operating and Installation Guide will help you learn about your Lifebreath Clean Air Furnace quickly and easily. The table of contents will show you where to find information on every feature of this unit along with easy to understand operating instructions. If, however, you do encounter a question that is not covered in this Guide you should call the Lifebreath dealer who installed your furnace. Chances are that he will be able to give you a satisfactory answer but if he is unable to do so then we invite you to contact us directly.

General

The purpose of this manual is to act as an installation guide only for the Lifebreath Clean Air Furnace.

All national and local code requirements must be met when installing a Lifebreath Clean Air Furnace. Be sure to consult the proper authorities.

Table of Contents

Introduction	1
Table of Contents.....	1
General	1
Specifications.....	2-4
Installation.....	5-10
Wiring Diagram	11
Start-up Procedure.....	12
Operation	13
Troubleshooting	14
Maintenance and Service Record	15



Core

Ventilation system has patented aluminum heat recovery core for energy-efficient ventilation.

Filters

Washable air filters in exhaust and supply air streams of ventilation section, 1" Pleated in return plenum side.

Case

Prepainted galvanized steel for superior corrosion resistance.

Specifications	18kw = (60,000 BTUH)
Voltage	240 VAC 60 Hz
Hp	1/3
Amps (total)	85
Stages	Single (4 sequence)
Ventilation Ducts	6"
Return Plenum	14" x 22"
Supply Airflow	17.25" x 16" 1350 CFM @ .25 ESP 1180 CFM @ .5 ESP
Ventilation Airflow	140 CFM
Effectiveness (HRV)	70%

*Note: All connections to be made by qualified contractors.
Net Weight 150 lbs. Shipping Weight 165lbs.*

Dimensions & Clearances

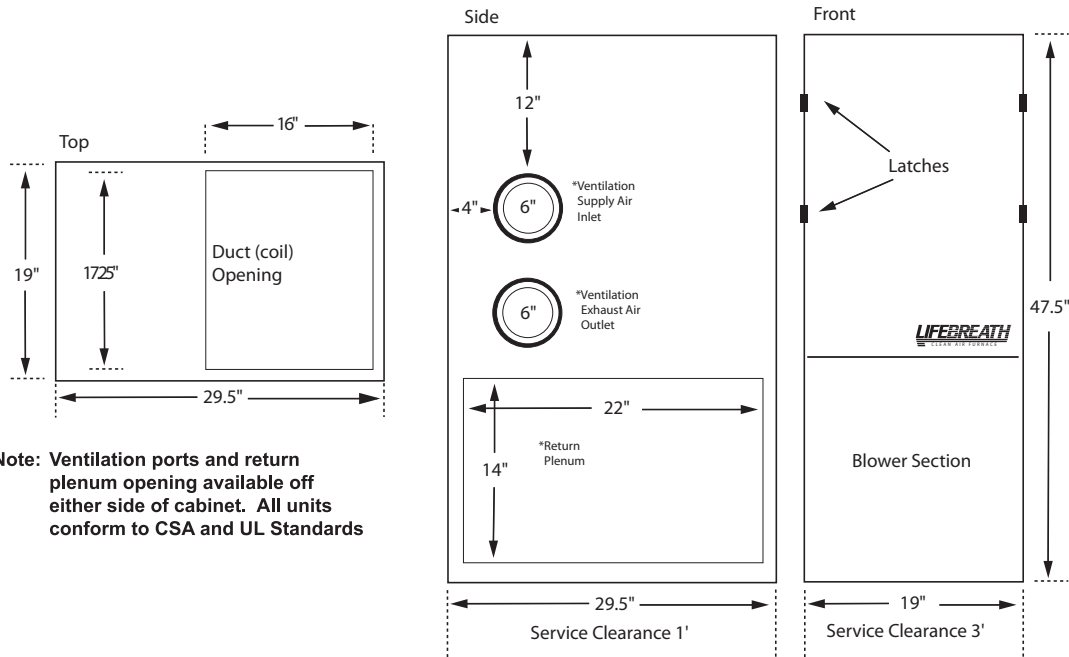

Note: Ventilation ports and return plenum opening available off either side of cabinet. All units conform to CSA and UL Standards

Options

- 99-186** Weatherhoods, Two - 6" c/w 1/4" mesh screen
- 99-130W** Remote Wall Mount Dehumidistat Control 24 VAC only,
- 99-122** 6" Balancing Damper
- 99-RSK6** 6" Backdraft Damper

Warranty

Units carry a lifetime warranty on the heat recovery core and a five year replacement parts warranty on all other components.



511 McCormick Blvd.
London, Ontario N5W 4C8
T (519) 457-1904
F (519) 457-1676
Email: nutech@lifebreath.com

270 Regency Ridge, Suite 210
Dayton, Ohio 45459
T (937) 439-6676
F (937) 439-6685
Website: www.lifebreath.com



Core

Ventilation system has patented aluminum heat recovery core for energy-efficient ventilation.

Filters

Washable air filters in exhaust and supply air streams of ventilation section, 1" Pleated in return plenum side.

Case

Prepainted galvanized steel for superior corrosion resistance.

Specifications 18kw = (60,000 BTUH)	
Voltage	240 VAC 60 Hz
Hp	1/3
Amps (total)	85
Stages	Single (4 sequence)
Ventilation Ducts	6"
Return Plenum	14" x 22"
Supply Airflow	17.25" x 16" 1350 CFM @ .25 ESP 1180 CFM @ .5 ESP
Ventilation Airflow	140 CFM
Effectiveness (HRV)	70%

Note: All connections to be made by qualified contractors. Net Weight 150 lbs. Shipping Weight 165lbs.

Dimensions & Clearances

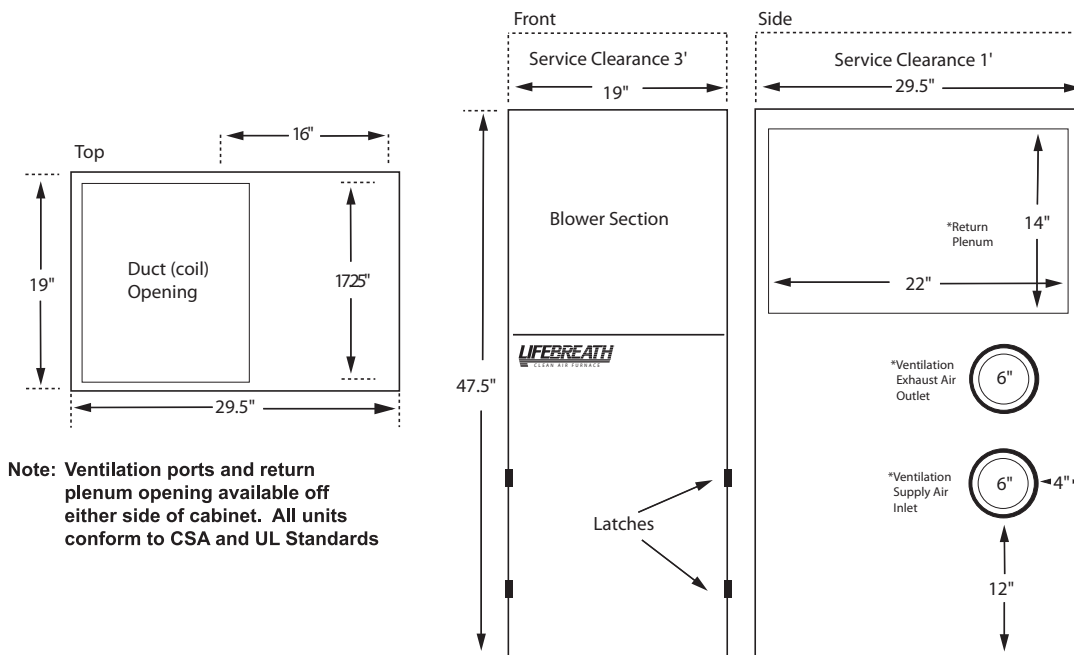

Options

- 99-186 Weatherhoods, Two - 6" c/w 1/4" mesh screen
- 99-130W Remote Wall Mount Dehumidistat Control 24 VAC only,
- 99-122 6" Balancing Damper
- 99-RSK6 6" Backdraft Damper

Warranty

Units carry a lifetime warranty on the heat recovery core and a five year replacement parts warranty on all other components.



511 McCormick Blvd.
London, Ontario N5W 4C8
T (519) 457-1904
F (519) 457-1676

Email: nutech@lifebreath.com

270 Regency Ridge, Suite 210
Dayton, Ohio 45459
T (937) 439-6676
F (937) 439-6685

Website: www.lifebreath.com



Figure 1
Blower Performance Curve

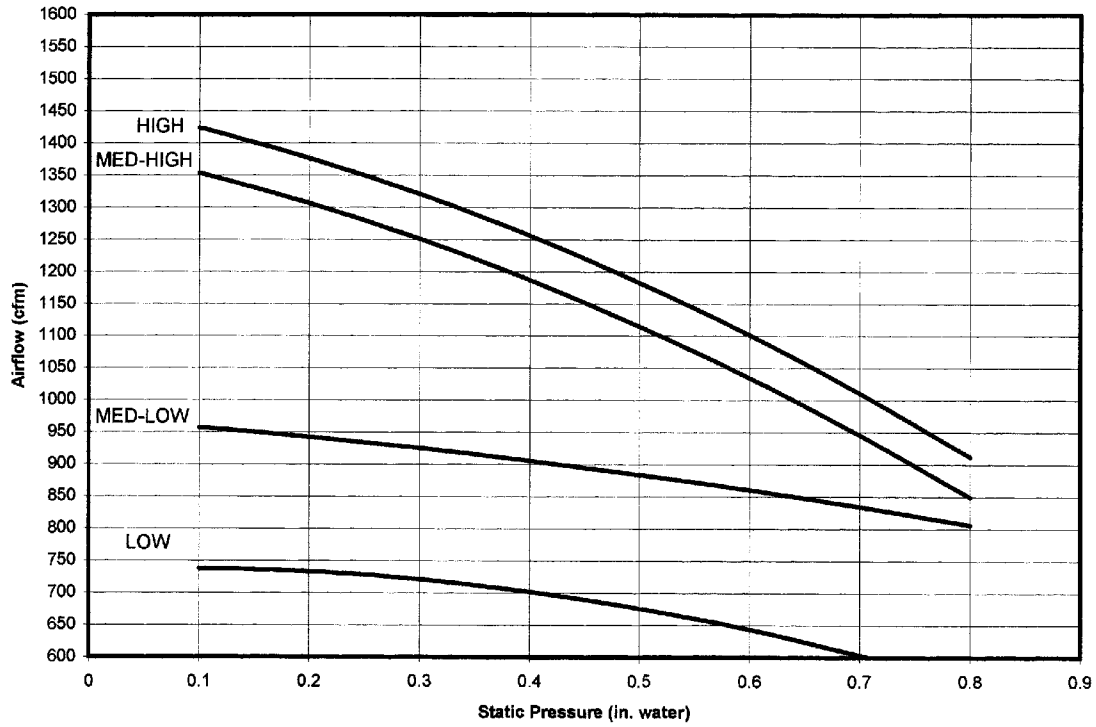

Installation

The purpose of this manual is to give the contractor guidelines for installing the Lifebreath Clean Air Furnace. All national and local codes relating to this type of equipment must be followed.

Locating The Unit

The Clean Air Furnace is designed to be installed vertically, in a conditioned space, where the surrounding temperature does not fall below 50°F (10°C). Attic installations are not recommended. Typically the unit is installed in a mechanical area of the basement, or other partitioned mechanical room, elsewhere in the home.

A location close to an outside wall is recommended, as the ventilation supply and exhaust portion will need to be ducted to the outside air.

Sufficient clearance around the unit is required for service of the filter, heat recovery core and components.

Duct Connections

To accommodate various installations, the Clean Air Furnace has knockouts for the return air plenum and ventilation ducts, on both sides of the cabinet. Special care and attention should be given to determining which knockouts are to be removed. (See Fig. 2 & Fig. 3).

Slide Heat Recovery Core out to remove ventilation knockouts. Never install ductwork directly to the cabinet that is smaller than the opening provided.

Figure 2
Option 1 - Ventilation Ports Off Left Side

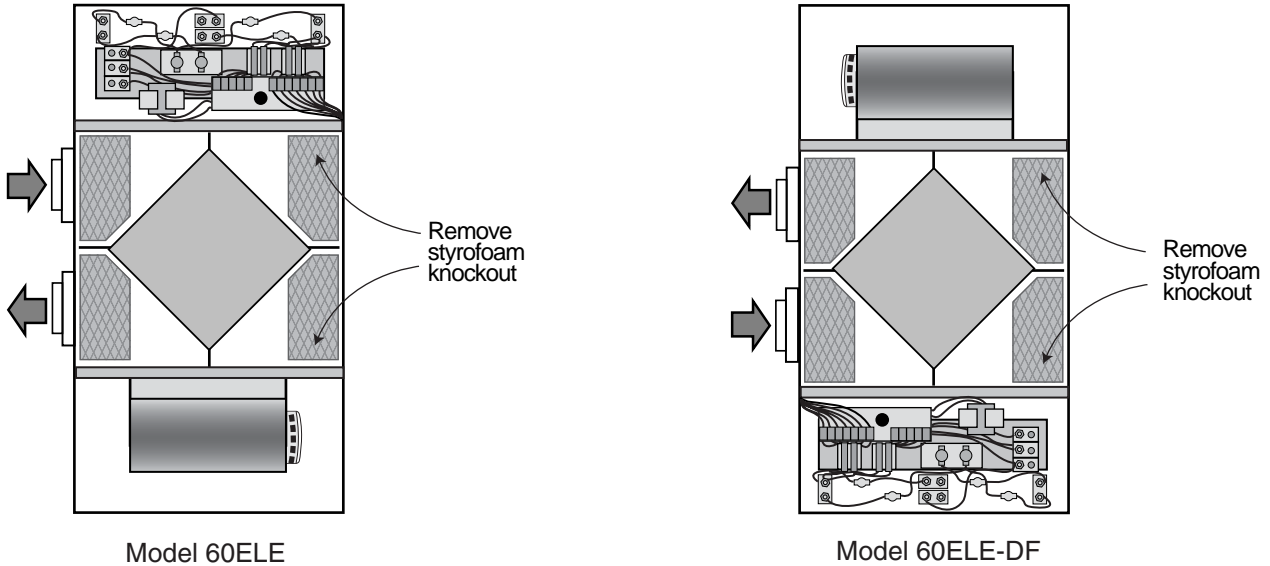

NOTE: Return plenum opening can be on either side of cabinet and is not dependent on which side the ventilation ports are on.

Figure 3
Option 2 - Ventilation Ports Off Right Side

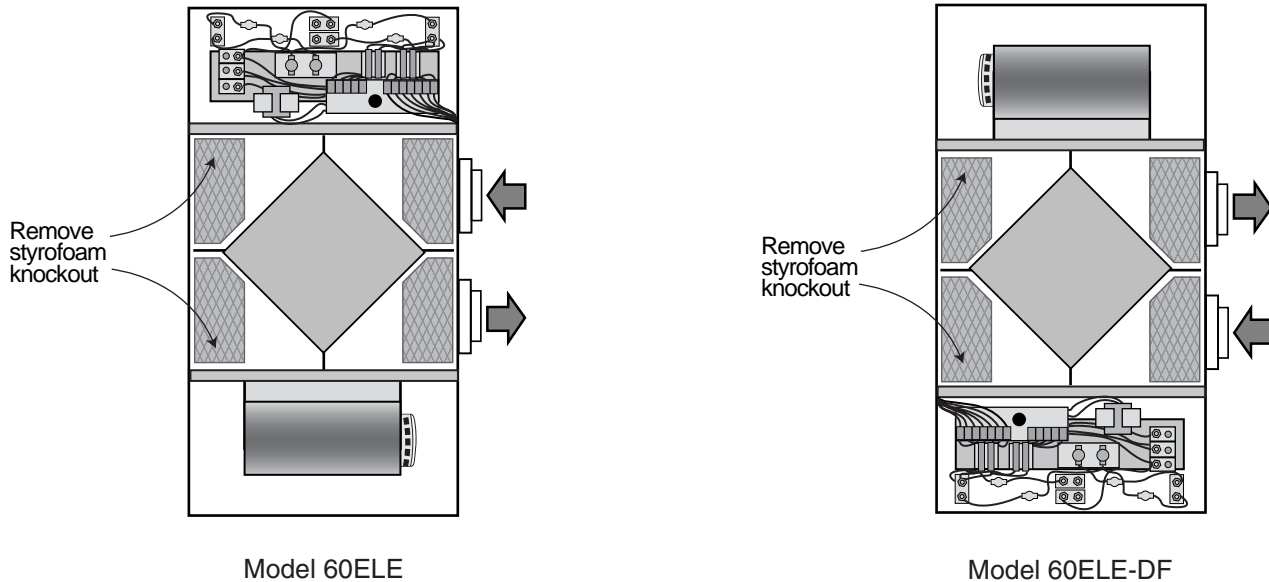

Penetrations from sheet metal screws used to fasten the ductwork to the cabinet of the unit should only be placed into the duct flange provided. This is to avoid contact and damage of the heating/air conditioning coils and internal wiring.

Ducting

The duct sizing for the furnace section can be determined using HRAI Residential Air System Design Manual, SMACNA, or any other industry-recognized manuals.

Any ductwork running through unconditioned space must be sealed properly and insulated to prevent heat loss. All local codes must be followed in determining the amount of insulation needed.

The ventilation section consists of two 6" (15.2cm) round ports located on the side of the cabinet, which vent to the outside. Insulated ducting with a vapour barrier such as flex-ducting, or ridged pipe wrapped in pipe sleeve, is required to prevent condensation from occurring on the pipe. Also the airflow in these lines is designed to be balanced. (See "Balancing Airflows" in this manual, for damper location and procedure.)

Warning: A backdraft damper is required in the exhaust air duct to prevent cold air from entering the unit when the Clean Air Furnace is not running. Fig. D Page 9.

Locating Intake Weatherhood

The intake weatherhood should be located as follows:

- * 4-6' from ventilation exhaust hood, and upstream of prevailing winds, if possible.
- * At least 6' from a dryer vent, oil fill pipes, combustion outlets, gas meters, garbage containers or anything else, which may contaminate the air.
- * Do not locate fresh air intake in garages, crawl spaces or attics.
- * Install 18" above grade, or above expected snow accumulation.

Installation

Locating the Exhaust Weatherhoods

The Exhaust Weatherhood should be located as follows:

- * At least 4-6' from the supply inlet.
- * At least 18" above grade or expected snow accumulation.
- * At least 3' from gas meters, combustion vents, or dryer vents.
- * Do not install in garages, crawl spaces or attics.

Outside Ducting the Weatherhoods

The ventilation portion of the Clean Air Furnace can be vented off either side of the unit by removing knockouts provided. Once the knockouts in Fig. 2 / Fig. 3 are removed, a bead of silicone can be placed on the plastic thermo-collars (provided), to form a seal between the collars and the cabinet. The collars can then be fastened into place with screws. Note the exhaust outlet is always the port on the bottom, and the supply inlet is always the port on the top, both ports should be labeled from the factory as such.

A small piece of rigid duct (1-2') can be fabricated for joining the outside ducting to the port collars. (Fig. D, page 12). This section of pipe is needed to accommodate the balancing damper, as required in the "Balancing Procedure" in this manual. After installing the dampers, the small section of pipe can be fastened to the port collars. The ductwork from the outside weatherhoods to the unit, is usually flexible ducting, although rigid pipe may be needed if the runs are greater than 20 feet. In either case the pipes (both exhaust and supply and the added fittings) must be insulated, with a complete vapor barrier Fig. 4. To minimize restriction in airflows the ducting should be short, with as few bends as possible. See diagram below for recommended connection of insulated ducting to outside weatherhoods and the Clean Air Furnace port collars.

Figure 4
Locating Weatherhood

WEATHERHOOD INSTALLATION

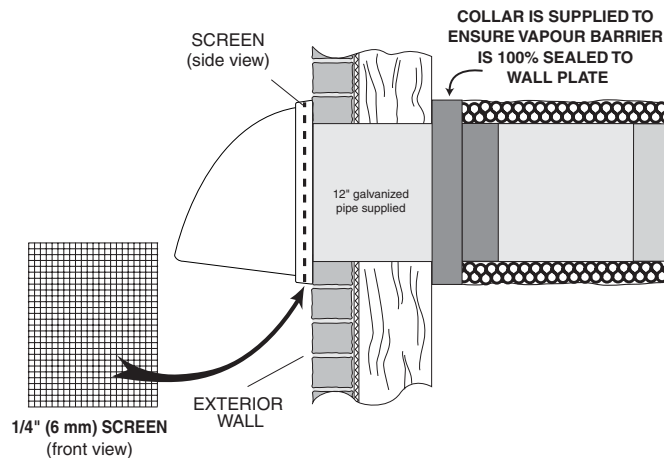

1. Thermal Collar slides over galvanized sleeve of Weatherhood.
2. Fasten Thermal Collar to Belt.
3. Slide the Insulated Flexible Ducting over the Weatherhood's galvanized sleeve and fasten it to the Thermal Collar.
4. Hood is hinged to allow for easy access for cleaning of bird screen.

Installation

Pitot Tube Air Flow Balancing

It is necessary to have balanced air flows in an HRV. The volume of air brought in from the outside must equal the volume of air exhausted by the unit. If the air flows are not properly balanced then:

- * The HRV may not operate at its maximum efficiency
- * A negative or positive air pressure may occur in the house
- * The unit may not defrost properly
- * Failure to balance the HRV may void warranty

Prior to balancing, ensure that:

1. All sealing of the ductwork system has been completed.
2. All of the HRV's components are in place and functioning properly.
3. Balancing dampers are fully open.
4. Unit is on high speed.
5. After taking readings of both the stale air to the HRV duct and fresh air to the house duct, the duct with the lower CFM ([L/s] velocity) reading should be left alone, while the duct with the higher reading should be dampered back to match the lower reading.
6. Return unit to appropriate fan speed for normal operation.

Balancing Procedure

The following is a method of field balancing an HRV using a Pitot tube, advantageous in situations when flow stations are not installed in the ductwork. Procedure should be performed with the HRV on high speed.

Choose the straightest section of duct between the HRV and the weatherhoods. This will be used for both the supply and return ducts.

Drill a small hole in the duct (about 3/16"), three feet downstream of any elbows or bends, and one foot upstream of any elbows or bends. These are recommended distances but the actual installation may limit the amount of straight duct.

The Pitot tube should be connected to a magnehelic gauge or other manometer capable of reading from 0 to 0.25 in. (0 - 62 Pa) of water, preferably to 3 digits of resolution. The tube coming out of the top of the Pitot is connected to the high pressure side of the gauge. The tube coming out of the side of the Pitot is connected to the low pressure or reference side of the gauge.

Insert the Pitot tube into the duct, pointing the tip into the airflow.

Installation

For general balancing it is sufficient to move the Pitot tube around in the duct and take an average or typical reading. Repeat this procedure in the other (supply or return) duct. (Fig. B.). Determine which duct has the highest airflow (highest reading on the gauge). Then damper that airflow back to match the lower reading from the duct. The flows should now be balanced.

Actual airflow can be determined from the gauge reading. The value read on the gauge is called velocity pressure.

The 6" duct has a cross sectional area of:

$$= (3.14 \times [6" \div 12]^2) \div 4$$

$$= 0.2 \text{ square feet}$$

The airflow is then 640 ft./min x 0.2 square feet = 128cfm

For your convenience, the cross sectional area of some common round duct is listed below:

DUCT DIAM. (inches)	CROSS SECTION AREA (sq. ft.)
5.0	.14
6.0	.20
7.0	.27

The accuracy of the airflow reading will be affected by how close to any elbows or bends the readings are taken. Accuracy can be increased by taking an average of multiple readings as outlined in the literature supplied with the Pitot tube.

The Pitot tube comes with a chart that will give the air flow velocity based on the velocity pressure indicated by the gauge. This velocity will be either feet per minute or metres per second. To determine the actual airflow, the velocity is multiplied by the cross sectional area of the duct being measured.

This is an example for determining the airflow in a 6" duct. The Pitot tube reading was 0.025 inches of water. From the chart, this is 640 feet per minute.

Figure D

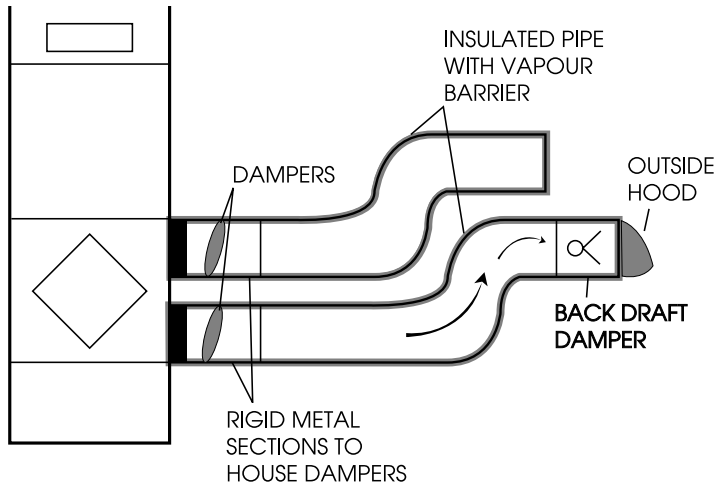

***Note: All dampers & fittings must be covered with insulation and sealed with tape**

**Figure A:
Pitot Tube Air Flow Balancing Kit**

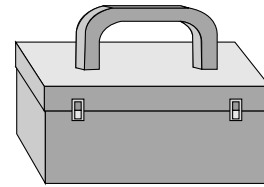

c/w magnetic gauge, Pitot tube, hose and carry case.
PART NO. 99-167

**Figure B:
Pitot Tube and Gauge**

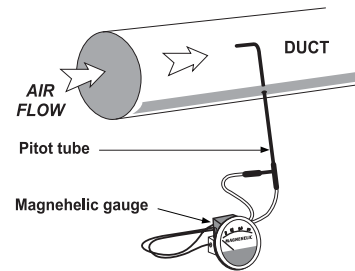

Note: For best results, keep Pitot tube well away from dampers and motor turbulence.

**Figure C:
Placement of the Pitot Tube**

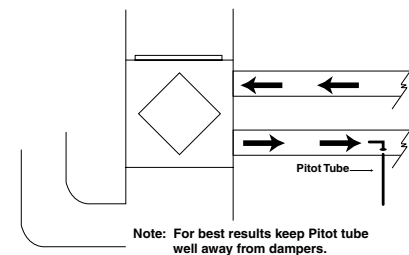

Note: For best results keep Pitot tube well away from dampers.

Installation

Drain Line

The ventilation portion of the Clean Air Furnace has two drain pans for removing condensation, which may occur on the heat recovery core during cold weather. See Fig. 5, for connection.

Figure 5
Drain Line Diagram

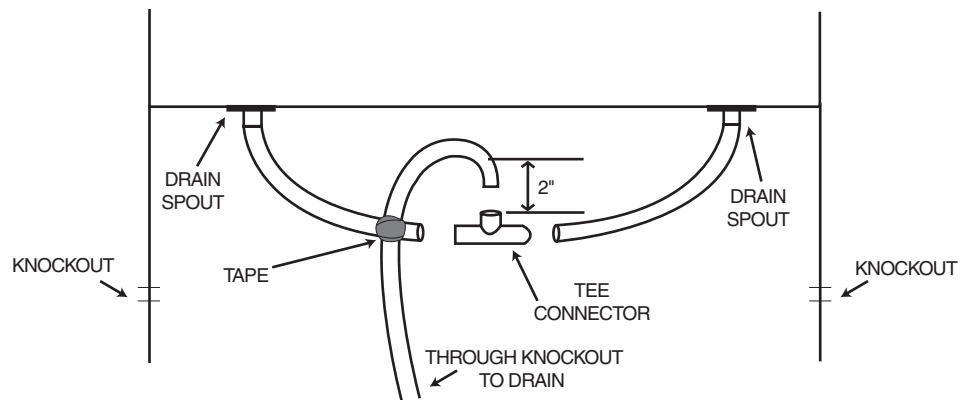

Wiring Diagram

R - W = Heat
 R - G = Fan Only (optional dehumidistat)
 G - R - Y - C = A/C

Electrical

The Clean Air Furnace operates at 240V, single phase and requires a maximum 100amp fused circuit or breaker.

The low voltage thermostat (not provided) connects to the R & W terminals for heating and the R & Y & C terminals when calling for cooling.

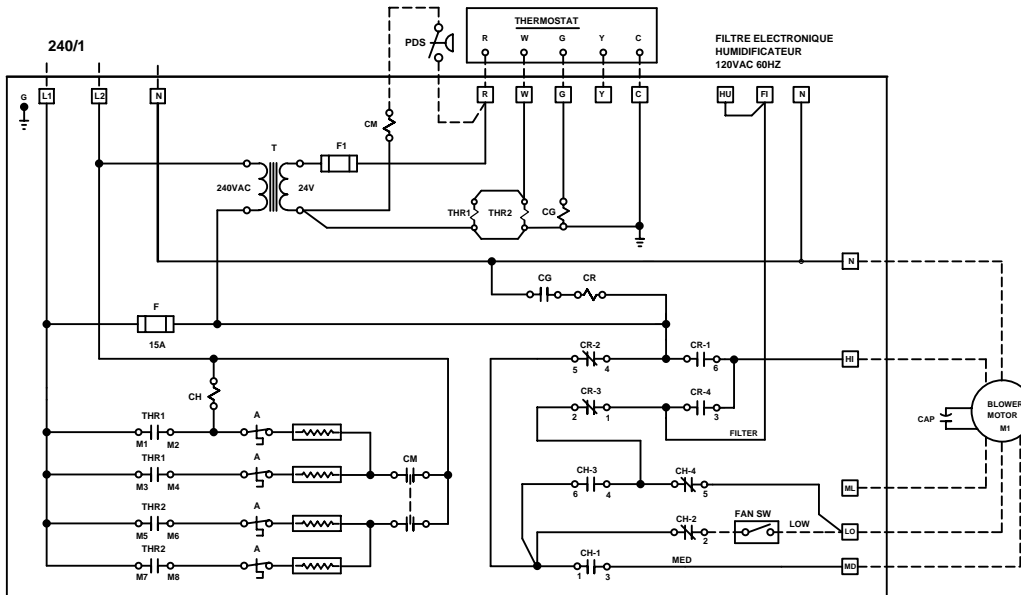

IMPORTANT
 WIRE IN ACCORDANCE WITH LOCAL AND CANADIAN ELECTRICAL CODES. READ CAREFULLY INSTALLATION INSTRUCTION BEFORE WIRING AND OPERATING.

LEGEND
 A AUTOMATIC RESET CUT-OUT
 THR THERMAL RELAY
 T CONTROL CIRCUIT TRANSFORMER
 E1..E4 HEATING ELEMENTS
 CH BLOWER RELAY 2 SPEEDS
 F FUSE 15 AMPS 250 V
 PDS PRESSURE DIFFERENTIAL SWITCH
 CM BACK-UP CONTACTOR
 CR COOLING CONTACTOR
 HU HUMIDIFIER
 EF ELECTRONIC AIR FILTER
 M1 BLOWER MOTOR 120VAC
 CAP CAPACITOR
 CG COOLING RELAY

IMPORTANT
 SUIVRE LES CODES ELECTRIQUE NATIONAUX ET LOCAUX ANSI QUE LES INSTRUCTIONS CONTENUES DANS L'APPAREIL.

LÉGENDE
 A SONDE THERMIQUE À RESET AUTOMATIQUE
 THR RELAIS THERMIQUE
 T TRANSFORMATEUR
 E1..E4 ÉLÉMENTS DE CHAUFFAGE ELECTRIQUE
 CH RELAIS DE MOTEUR, 2 VITESSES
 HU HUMIDIFICATEUR
 EF FILTRE À AIR ELECTRONIQUE
 M1 MOTEUR DE VENTILATEUR
 PDS INTERRUPTEUR À PRESSION DIFFERENTIELLE
 CM CONTACTEUR SECONDAIRE
 CR CONTACTEUR DE CLIMATISATION
 CAP CONDENSATEUR
 F FUSIBLE 15 AMP, 250V
 CG RELAIS DE CLIMATISATION

SUPPLY CIRCUIT	FOR MINIMUM SUPPLY CONNECTION USE 75°C COPPER. AWG SIZE
240V/1 18 KW	#3

CODE	DESCRIPTION	MAKE	MODEL	RATING	PART #	QTY.
A	AUTOMATIC RESET CUT-OUT	THERMO DISC	60TX11-312373	25 AMP 277V	CC0 010	4
F	FAN MOTOR, ELECT. FILTER & HUM. SUPPLY FUSEHOLDER	BUSS	HKP-HH	15 AMP 240V	CFH 015	1
F	FAN MOTOR, ELECT. FILTER & HUM. SUPPLY FUSE	BUSS	MDL 15	15 AMP 240V	CFU 035	1
THR	4 POLE SEQUENCER	THERMODISC	15S24	25 AMP 240V	CCT 130	1
CR	COOLING FAN RELAY COIL 120V 50/60HZ	HONEYWELL	R4222D1039	15A 277V	DEC 010	1
CH	HEATING FAN RELAY COIL 208/240V 50/60HZ	PRODUCTS UNLIMITED	9100-233U999	15A 277V	CCT 145	1
FAN SW	LOW SPEED CONTINUOUS	CARLINGSWITCH	115A13-2XA	16A 120V	PMC 012	1
T	CONTROL TRANSFORMER	PRODUCT UNLIMITED	4000-09AW18AE887	240V/24V 50VA	CTR 090	1
G	GROUND LUG	ILSCO	TA-6-I	35 AMP	CLG 010	1
R-C	CONTROL TERMINAL BLOCK TO THERMOSTAT	WECO	324-FU-HDS/12	15 AMP 240V	CP1 054	1
HU-MD	BLOWER MOTOR, ELECT. FILTER & HUM. TERMINAL BLOCK	WECO	324-FU-HDS/12	15 AMP 240V	CPI 056	1
L1..3	POWER TERMINAL 3 POLE	THERMOLEC	3P-PWR-BLK	125 AMPS	CP1 070	1
CG	CONTROL RELAY COIL 24V	STEVECO	134-20102101ZZ	25 AMPS	CCT 139	1
PDS	PRESSURE DIFFERENTIAL SWITCH	CLEVELAND	DFS-221-112	15 AMP 240V	CAF 010	1

*120 Volt terminals are provided for connecting an air filtration device/humidifier. These terminals are labeled **HU** **F1** **N** as shown above.

Start Up Procedure

In order for any appliance to work properly it must be set up and tested by a knowledgeable technician.

The following conditions must be met prior to start-up

1. Blower wheel rotates freely inside its housing.
2. Wiring connections are tight.
3. Water is sitting in the "P" trap below the HRV core.
4. All duct and pipe connections are sealed.
5. Front access door is on tight.

Once all of the necessary connections have been made, the Clean Air Furnace Start-Up Procedure is as follows:

1. Turn on power supply to Clean Air Furnace. Caution: The blower will start running at a lower speed.
2. Switch the room thermostat to heat. The thermostat should be set higher than the current room temperature in order to energize the unit and commence the heating cycle. Verify heat cycle starts.
3. Set room thermostat at desired temperature setting.
4. Switch fan to manual at the thermostat so the unit will run at high speed in order to perform the balancing procedure on the ventilation section.

Note: For ECM motors, refer to note located on this page regarding high speed fan operation.

5. After balancing the ventilation according to instructions, set the thermostat fan switch to "auto". On "auto" the fan will run continuously at a low speed if the ventilation switch (fig. 6) is in the continuous mode, until heating or cooling is called for and then will switch to a higher speed. On "manual" the fan will run at high speed continuously.

NOTE: Continuous low speed can be turned ON/OFF with the ventilation switch, (fig. 6).

NOTE: Continuous high speed can be obtained by switching thermostat fan switch to manual/on.

NOTE: For models with the ECM blower motor. Low speed fan is controlled by the thermostat fan switch (R and G terminals).

High speed blower operation is obtained by making a dry contact closure across R and the Orange wire from the ECM motor.

NOTE: Downflow models incorporate a flow switch to verify blower operation and airflow. If airflow is not sensed or the pressure switch is blocked, the electric heating elements will NOT start. NEVER override or disable safety switches. If airflow is blocked or too low, the airflow MUST be diagnosed and corrected.

Operation

Heating/Cooling

When the room thermostat calls for heat, the furnace blower switches on to heating speed and will start circulating air across the coil, which picks up heat and delivers it to the rest of your home.

Once the thermostat's temperature is reached the elements will shut off, and the blower will return to its pre-set speed or off.

Note: When the furnace blower is left running on low speed the air in the home circulates continuously. When the heat is called for the blower will automatically switch to a higher speed. After the required hot air has been delivered the blower will switch back to low speed.

When the thermostat calls for cooling (optional A coil and condensing unit required) the furnace blower activates to high speed and the outdoor condenser unit is energized. After the thermostat temperature is reached the condensing unit will shut off, and the blower will return to its low speed. Continuous low speed is selectable, (fig. 6).

Ventilation

The heat recovery ventilation (HRV) portion of the Clean Air Furnace, is automatic. Once set, a desired amount of fresh air will be drawn into the home while the furnace blower is activated.

To reduce humidity increased ventilation may be required. An optional remote dehumidistat can be installed. The dehumidistat will increase the speed of the furnace blower to high and will return to its original setting when humidity levels decrease. Your dehumidistat must be switched off during warmer months as it is not required for air conditioning operation. To increase humidity a quality humidifier should be added to the system.

Typically the air flow for ventilation will be set to 50 - 70cfm, for low speed furnace operation, and 100 - 150cfm at high speed. The pleated furnace filter should be checked regularly and replaced as needed. The HRV filter should be washed twice a year or more often if needed.

Figure 6

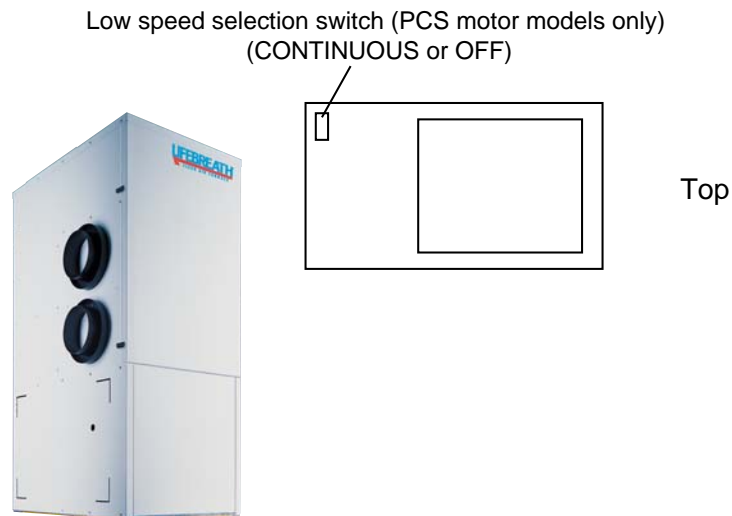

Lack of heat

1. Check that the room thermostat is set to the desired temperature.
2. Ensure there is power to the unit.
3. Verify that the airflow in and out of the system matches designed specs. If airflow is low, check for blockage in the filter or some other obstruction.

HRV core freezes up

1. Make sure that the supply and exhaust lines are balanced according to the "Balancing Procedure" in this manual.
2. If out of balance, ensure that the balancing dampers have not been moved and that there are no obstructions in the outside hoods.
3. If necessary, install optional defrost kit, according to instructions.

Water sits in drain pipes

1. Check drain pans or lines for plugs.
2. Confirm that the HRV core is installed according to manufactures recommendations.
3. Check the drain line for kinks.
4. Make sure that the O-ring in the drain nozzles sit flat.
5. Ensure the drain line has enough "fall" to it.

Condensation/ice forming inside ventilation ducts

A rip in the vapor barrier or poorly sealed joints may cause condensation or ice to form on the ducting. If this occurs, replace the entire line.

Humidity levels are too low

1. If you have installed a dehumidistat ensure that its setting is correct.
2. Check humidifier settings.
3. Change thermostat fan switch from manual to automatic.
4. Change ventilation switch on furnace from continuous (low) to automatic.

Humidity levels are too high

1. If you have installed a dehumidistat ensure its setting is correct.
2. Install a dehumidistat if necessary
3. Change ventilation switch on furnace from automatic to continuous.
4. Change thermostat fan switch from automatic to manual.



nutech
BRANDS INC.

511 McCormick Blvd.
London, Ontario N5W 4C8
T (519) 457-1904
F (519) 457-1676
Email: nutech@lifebreath.com

270 Regency Ridge, Suite 210
Dayton, Ohio 45459
T (937) 439-6676
F (937) 439-6685
Website: www.lifebreath.com

ISO
9001
REGISTERED