

**INSTALLER:** LEAVE THIS MANUAL WITH THE APPLIANCE  
**CONSUMER:** RETAIN THIS MANUAL FOR FUTURE REFERENCE

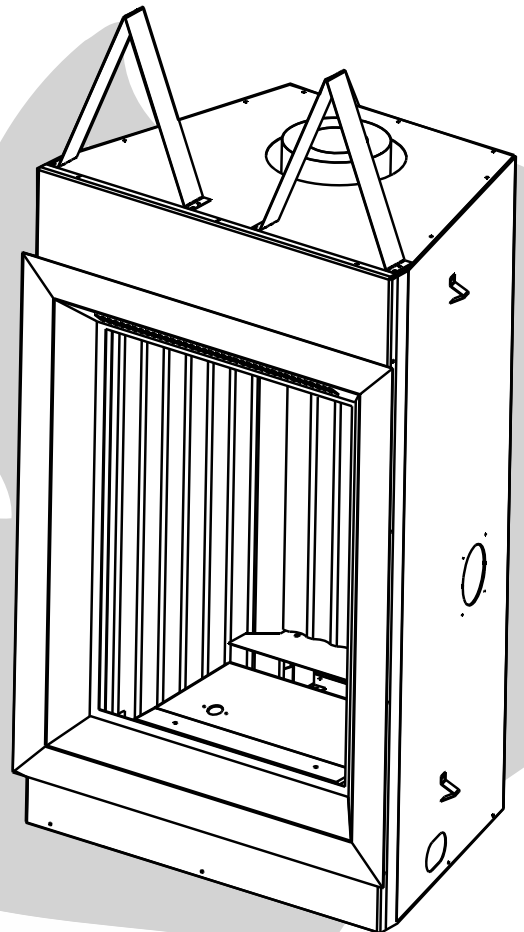


# INSTALLATION AND OPERATION INSTRUCTIONS

CERTIFIED UNDER CANADIAN AND AMERICAN NATIONAL STANDARDS: CSA 2.33, ANSI Z21.88 FOR VENTED GAS FIREPLACE HEATERS.

# Park Avenue™

**GD82NT-PA**  
NATURAL GAS  
**GD82PT-PA**  
PROPANE



CERTIFIED FOR CANADA AND UNITED STATES USING ANSI/CSA METHODS.

## SAFETY INFORMATION

### ⚠ WARNING

If the information in these instructions are not followed exactly, a fire or explosion may result causing property damage, personal injury or loss of life.

- Do not store or use gasoline or other flammable vapors and liquids in the vicinity of this or any other appliance.
- **WHAT TO DO IF YOU SMELL GAS:**
  - Do not try to light any appliance.
  - Do not touch any electrical switch; do not use any phone in your building.
  - Immediately call your gas supplier from a neighbour's phone. Follow the gas supplier's instructions.
  - If you cannot reach your gas supplier, call the fire department.
- Installation and service must be performed by a qualified installer, service agency or the supplier.



Wolf Steel Ltd., 24 Napoleon Rd., Barrie, ON L4M 4Y8 Canada • (705)721-1212 • fax(705)722-6031  
www.napoleonfireplaces.com • ask@napoleon.on.ca

# TABLE of CONTENTS

|              |   |  |
|--------------|---|--|
| <b>PG2-5</b> | <b>INTRODUCTION</b><br>Warranty<br>Fireplace Dimensions<br>Installation Overview<br>General Instructions<br>General Information<br>Care of Glass  | Log Shipping Bracket<br>Decorative Brick Panel Installation<br>Log Placement<br>Glowing Embers<br>AFK / WI FACE KIT Installation   |
| <b>6-11</b>  | <b>VENTING</b><br>Vent lengths<br>Venting Specifications<br>Minimum Air Terminal Location Clearances  | <b>21-22</b> <b>SERVICING / REPLACEMENTS</b><br>Glass / Door Replacement<br>Blower Replacement<br>Burner and Valve Replacement<br>Spark Module Battery Replacement<br>Night Light™ Replacement |
| <b>12-18</b> | <b>INSTALLATION</b><br>Wall & Ceiling Protection<br>Horizontal Installation<br>Vertical Installation<br>Using Flexible Vent Components<br>Horizontal Air Terminal Installation<br>Vertical Air Terminal Installation<br>Fireplace Vent Connection<br>Using Rigid Vent Components<br>Horizontal Air Terminal Installation<br>Extended Horizontal Air Terminal Installation<br>Vertical Air Terminal Installation<br>Mobile Home<br>Gas Installation<br>Restricting Vertical Vents<br>Minimum Framing Clearances<br>Minimum Enclosure Clearances<br>Minimum Mantel and Enclosure Clearances | <b>22-24</b> <b>OPERATION</b><br>Fireplace Operation<br>Hand Held Remote Operation<br>Operating Instructions   |
| <b>18</b>    | <b>ELECTRICAL CONNECTION</b><br>Hard Wiring Connections<br>Electrical Schematic   | <b>25</b> <b>OPERATING INSTRUCTIONS</b><br><b>26</b> <b>ADJUSTMENTS</b><br>Maintenance<br>Pilot Burner Adjustment<br>Flame Characteristics<br>Venturi Adjustment                               |
| <b>19-20</b> | <b>FINISHING</b><br>Door Removal  | <b>27-28</b> <b>REPLACEMENTS</b><br>Ordering Replacement Parts<br>Replacement Parts<br>Flexible Vent Kits<br>Terminal Kits<br>Roof Terminal Kits<br>Accessories                                |
|              |   | <b>29-30</b> <b>TROUBLE SHOOTING GUIDE</b><br><b>31</b> <b>FIREPLACE SERVICE HISTORY</b><br><b>32</b> <b>NOTES</b>   |

**PLEASE RETAIN THIS MANUAL FOR FUTURE REFERENCE**

## WARNING

- Do not burn wood or other materials in this fireplace.
- Adults and especially children should be alerted to the hazards of high surface temperatures and should stay away to avoid burns or clothing ignition. Supervise young children when they are in the same room as the fireplace.
- Clothing or other flammable material should not be placed on or near the fireplace.
- Due to high temperatures, the fireplace should be located out of traffic and away from furniture and draperies.
- Ensure you have incorporated adequate safety measure to protect infants/toddlers from touching hot surfaces.
- Even after the fireplace is out, the glass and/or screen will remain hot for an extended period of time.
- Check with your local hearth specialty dealer for safety screens and hearth guards to protect children from hot surfaces. These screens and guards must be fastened to the floor.
- Any safety screen or guard removed for servicing must be replaced prior to operating the fireplace.
- It is imperative that the control compartments, burners and circulating blower and its passageway in the fireplace and venting system are kept clean. The fireplace and its venting system should be inspected before use and at least annually by a qualified service person. More frequent cleaning may be required due to excessive lint from carpeting, bedding material, etc. The fireplace area must be kept clear and free from combustible materials, gasoline and other flammable vapours and liquids.
- Under no circumstances should this fireplace be modified.
- This fireplace must not be connected to a chimney flue pipe serving a separate solid fuel burning appliance.
- Do not use this fireplace if any part has been under water. Immediately call a qualified service technician to inspect the fireplace and to replace any part of the control system and any gas control which has been under water.
- Do not operate the fireplace with the glass door removed, cracked or broken. Replacement of the glass should be done by a licensed or qualified service person.
- Do not strike or slam shut the fireplace glass door.
- This fireplace uses and requires a fast acting thermocouple. Replace only with a fast acting thermocouple supplied by Wolf Steel Ltd.
- Pressure relief doors must be kept closed while the fireplace is operating to prevent exhaust fumes containing carbon monoxide, from entering into the home. Temperatures of the exhaust escaping through these openings can also cause the surrounding combustible materials to overheat and catch fire.
- Only doors / optional fronts certified with the unit are to be installed on the appliance.

*NAPOLEON® products are manufactured under the strict Standard of the world recognized ISO 9001 : 2000 Quality Assurance Certificate.*

*NAPOLEON® products are designed with superior components and materials, assembled by trained craftsmen who take great pride in their work. The burner and valve assembly are leak and test-fired at a quality test station. The complete fireplace is again thoroughly inspected by a qualified technician before packaging to ensure that you, the customer, receives the quality product that you expect from NAPOLEON®.*

## **NAPOLEON® GAS FIREPLACE PRESIDENT'S LIFETIME LIMITED WARRANTY**

*The following materials and workmanship in your new NAPOLEON® gas fireplace are warranted against defects for as long as you own the fireplace. This covers: combustion chamber, heat exchanger, stainless steel burner, phazer™ logs and embers, gold plated parts against tarnishing, porcelainized enameled components and aluminum extrusion trims.*

*Electrical (110V and millivolt) components and wearable parts such as blowers, gas valves, thermal switch, switches, wiring, remote controls, ignitor, gasketing, and pilot assembly are covered and NAPOLEON® will provide replacement parts free of charge during the first year of the limited warranty.*

*Labour related to warranty repair is covered free of charge during the first year. Repair work, however, requires the prior approval of an authorized company official. Labour costs to the account of NAPOLEON® are based on a predetermined rate schedule and any repair work must be done through an authorized NAPOLEON® dealer.*

## **CONDITIONS AND LIMITATIONS**

NAPOLEON® warrants its products against manufacturing defects to the original purchaser only -- i.e., the individual or legal entity (registered customer) whose name appears on the warranty registration card filed with NAPOLEON®-- provided that the purchase was made through an authorized NAPOLEON dealer and is subject to the following conditions and limitations:

This factory warranty is nontransferable and may not be extended whatsoever by any of our representatives.

The gas fireplace must be installed by a licenced, authorized service technician or contractor. Installation must be done in accordance with the installation instructions included with the product and all local and national building and fire codes.

This limited warranty does not cover damages caused by misuse, lack of maintenance, accident, alterations, abuse or neglect and parts installed from other manufacturers will nullify this warranty.

This limited warranty further does not cover any scratches, dents, corrosion or discolouring caused by excessive heat, abrasive and chemical cleaners nor chipping on porcelain enamel parts, mechanical breakage of PHAZER™ logs and embers, nor any venting components used in the installation of the fireplace.

NAPOLEON® warrants its stainless steel burners against defects in workmanship and material for life, subject to the following conditions: During the first 10 years NAPOLEON® will replace or repair the defective parts at our option free of charge. From 10 years to life, NAPOLEON® will provide replacement burners at 50% of the current retail price.

In the first year only, this warranty extends to the repair or replacement of warranted parts which are defective in material or workmanship provided that the product has been operated in accordance with the operation instructions and under normal conditions.

After the first year, with respect to this President's Limited Lifetime Warranty, NAPOLEON® may, at its discretion, fully discharge all obligations with respect to this warranty by refunding to the original warranted purchaser the wholesale price of any warranted but defective part(s).

After the first year, NAPOLEON® will not be responsible for installation, labour or any other costs or expenses related to the reinstallation of a warranted part, and such expenses are not covered by this warranty.

Notwithstanding any provisions contained in this President's Limited Lifetime Warranty, NAPOLEON'S responsibility under this warranty is defined as above and it shall not in any event extend to any incidental, consequential or indirect damages.

This warranty defines the obligations and liability of NAPOLEON® with respect to the NAPOLEON® gas fireplace and any other warranties expressed or implied with respect to this product its components or accessories are excluded.

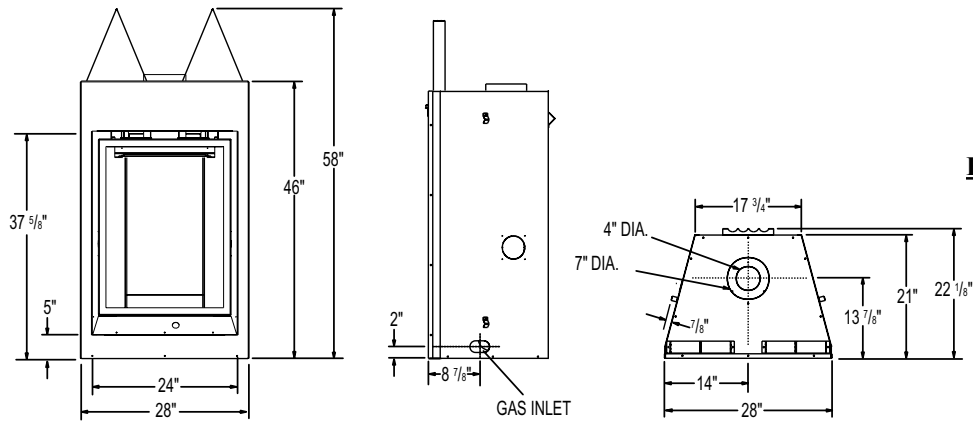
NAPOLEON® neither assumes, nor authorizes any third party to assume, on its behalf, any other liabilities with respect to the sale of this product. NAPOLEON® will not be responsible for: over-firing, downdrafts, spillage caused by environmental conditions such as rooftops, buildings, nearby trees, hills, mountains, inadequate vents or ventilation, excessive venting configurations, insufficient makeup air, or negative air pressures which may or may not be caused by mechanical systems such as exhaust fans, furnaces, clothes dryers, etc.

Any damages to fireplace, combustion chamber, heat exchanger, brass trim or other component due to water, weather damage, long periods of dampness, condensation, damaging chemicals or cleaners will not be the responsibility of NAPOLEON®.

The bill of sale or copy will be required together with a serial number and a model number when making any warranty claims from your authorized dealer. The warranty registration card must be returned within fourteen days to register the warranty.

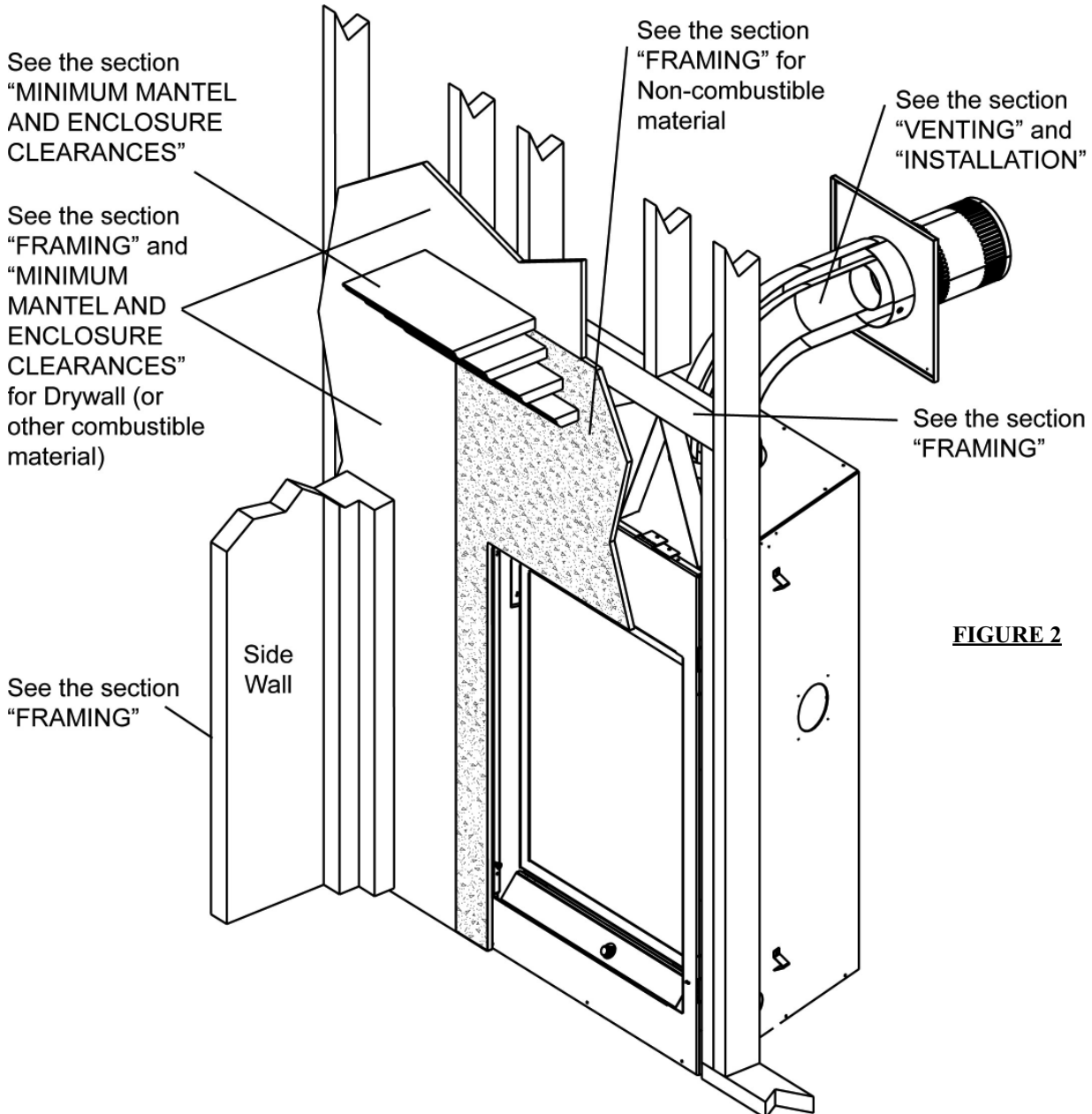
NAPOLEON® reserves the right to have its representative inspect any product or part thereof prior to honouring any warranty claim.

# FIREPLACE DIMENSIONS



**FIGURE 1**

# INSTALLATION OVERVIEW



**FIGURE 2**

## GENERAL INSTRUCTIONS

This gas fireplace should be installed and serviced by a qualified installer to conform with local codes. Installation practices vary from region to region and it is important to know the specifics that apply to your area,

for example: in Massachusetts State:

- The fireplace damper must be removed or welded in the open position prior to installation of a fireplace insert or gas log.
- The appliance off valve must be a "T" handle gas cock.
- The flexible connector must not be longer than 36 ".
- The appliance is not approved for installation in a bedroom or bathroom unless the unit is a direct vent sealed combustion product.
- A carbon monoxide detector is required in all rooms containing gas fired appliances.
- **WARNING:** This product must be installed by a licensed plumber or gas fitter when installed within the commonwealth of Massachusetts.

In absence of local codes, install to the current CAN/CGA -B149 Installation Code in Canada or to the National Fuel Gas Code, ANSI Z223.1, and NFPA 54 in the United States. Suitable for mobile home installation if installed in accordance with the current standard CAN/CSA Z240MH Series, for gas equipped mobile homes, in Canada or ANSI Z223.1 and NFPA 54 in the United States.

The fireplace and its individual shutoff valve must be disconnected from the gas supply piping system during any pressure testing of that system at test pressures in excess of 1/2 psig (3.5 kPa). The fireplace must be isolated from the gas supply piping system by closing its individual manual shutoff valve during any pressure testing of the gas supply piping system at test pressures equal to or less than 1/2 psig (3.5 kPa).

When the fireplace is installed directly on carpeting, vinyl tile or other combustible material other than wood flooring, the fireplace shall be installed on a metal or wood panel extending the full width and depth.

The optional heat circulating blower is supplied with a cord. If installed, the junction box must be electrically connected and grounded in accordance with local codes. In the absence of local codes, use the current CSA C22.1 canadian electrical code in Canada or the ANSI/NFPA 70 national electrical code in the United States.

**Provide adequate ventilation and combustion air.**

**Provide adequate accessibility clearance for servicing and operating the fireplace. Never obstruct the front opening of the fireplace.**

**Objects placed in front of the fireplace must be kept a minimum of 48" from the front face of the unit.**

## GENERAL INFORMATION

**FOR YOUR SATISFACTION, THIS FIREPLACE HAS BEEN TEST-FIRED TO ASSURE ITS OPERATION AND QUALITY!**

Maximum input is 26,000 BTU/hr for both natural gas and propane. When the fireplace is installed at elevations above 4,500ft, and in the absence of specific recommendations from the local authority having jurisdiction, the certified high altitude input rating shall be reduced at the rate of 4% for each additional 1,000ft. Maximum output for natural gas is 16150 BTU/hr at an efficiency of 62%; and 16150 BTU/hr for propane at an efficiency of 62%. Minimum inlet gas supply pressure is 4.5 " water column for natural gas and 11 " water column for propane. Maximum inlet gas pressure is 7 " water column for natural gas and 13 " water column for propane. Manifold pressure under flow conditions is 3.5 " water column for natural gas and 10 " water column for propane.

This fireplace is certified to be installed in an aftermarket permanently located, manufactured (mobile) home, where not prohibited by local codes.

No external electricity (110 volts or 24 volts) is required for the gas system operation.

This fireplace is only for use with the type of gas indicated on the rating plate. This fireplace is not convertible for use with other gases, unless a certified kit is used.

Expansion / contraction noises during heating up and cooling down cycles are normal and are to be expected. Change in flame appearance from "HI" to "LO" is more evident in natural gas than in propane.

**NATIONAL  
FIREPLACE  
INSTITUTE**



**CERTIFIED**  
www.nficertified.org

We Suggest that our gas hearth products be installed and serviced by professionals who are certified in the U.S. by the National Fireplace Institute® (NFI) as NFI Gas Specialists.

## CARE OF GLASS

Do not use abrasive cleaners to clean glass. Buff lightly with a clean dry cloth. The glass is 3/16" ceramic glass available from your Napoleon® / Wolf Steel Ltd. dealer. Do not substitute materials. Clean the glass after the first 10 hours of operation with a recommended gas fireplace glass cleaner. Thereafter clean as required. Do not clean glass when hot! If the glass is not kept clean permanent discoloration and / or blemishes may result.

## ! WARNING



**HOT GLASS WILL  
CAUSE BURNS.  
DO NOT TOUCH GLASS  
UNTIL COOLED.  
NEVER ALLOW CHILDREN  
TO TOUCH GLASS.**

# VENTING

## VENT LENGTHS

For safe and proper operation of the fireplace follow the venting instruction exactly.

Deviation from the minimum vertical vent length can create difficulty in burner start-up and/or carboning.

Provide a means for visually checking the vent connection to the fireplace after the fireplace is installed.

Vent lengths that pass through unheated spaces (attics, garages, crawl spaces) should be insulated with the insulation wrapped in a protective sleeve to minimize condensation.

Use only Wolf Steel, Simpson Dura-Vent, Selkirk Direct Temp or American Metal Amerivent venting components.

Wolf Steel, Simpson Dura-Vent, Selkirk Direct Temp and American Metal Amerivent venting systems must not be combined.

Follow the installation procedure provided with the venting components.

For vent systems that provide seals on the inner exhaust flue, only the outer air intake joints must be sealed using a red high temperature silicone (RTV). This same sealant maybe used on both the inner exhaust and outer intake vent pipe joints of all other approved vent systems except for the exhaust vent pipe connection to the fireplace flue collar which must be sealed using the black high temperature sealant MillPac. A starter adaptor must be used and may be purchased from the corresponding supplier:

| Supplier    | 4 / 7     |
|-------------|-----------|
| Duravent    | W175-0053 |
| Amerivent   | 4DSC-N2   |
| Direct Temp | 4DT-AAN   |

For Simpson Dura-Vent, Selkirk Direct Temp and American Metal Amerivent, follow the installation procedure found on the website for your venting supplier:

| VENTING SUPPLIER         | WEBSITE ADDRESS  |
|--------------------------|--|
| Simpson Dura-Vent        | <a href="http://www.duravent.com">www.duravent.com</a>                           |
| Selkirk Direct Temp      | <a href="http://www.selkirkcorp.com">www.selkirkcorp.com</a>                     |
| American Metal Amerivent | <a href="http://www.americanmetalproducts.com">www.americanmetalproducts.com</a> |

When using Napoleon® venting components, use only approved Wolf Steel Ltd. rigid / flexible vent components with the following termination kits: wall terminal kit GD222 and GD222R, or 1/12 to 7/12 pitch roof terminal kit GD110, 8/12 to 12/12 roof terminal kit GD111, flat roof terminal kit GD112 or periscope kit GD201 (for wall penetration below grade). With flexible venting, in conjunction with the various terminations, use either the 5 foot vent kit GD220 or the 10 foot vent kit GD330. These vent kits allow for either horizontal or vertical venting of the fireplace.

The maximum number of allowable 4" vent connections is three horizontally or vertically (excluding the fireplace and the air terminal connections).

For optimum flame appearance and fireplace performance, keep the vent length and number of elbows to a minimum.

Under extreme vent configurations, allow several minutes (5-15) for the flame to stabilize after ignition.

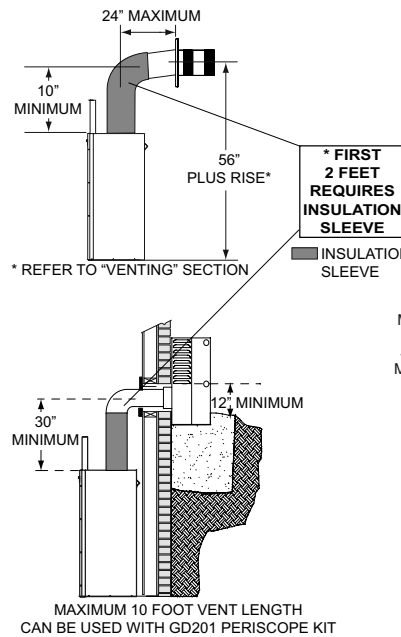
The air terminal must remain unobstructed at all times. Examine the air terminal at least once a year to verify that it is unobstructed and undamaged.

Horizontal runs may have a 0" rise per foot in all cases using Wolf Steel, Simpson Dura-Vent, Selkirk Direct Temp, or American Metal Amerivent rigid vent components and Wolf Steel flexible vent components.

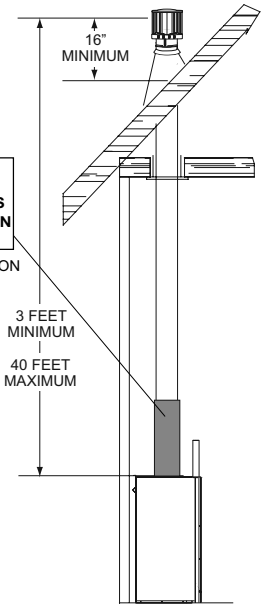
For optimum performance, it is recommended that horizontal runs have a minimum 1/4" rise per foot when using Wolf Steel, Simpson Dura-Vent, Selkirk Direct Temp, or American Metal Amerivent rigid vent components and a minimum of 1" rise per foot when using Wolf Steel flexible vent components.

When venting, the horizontal run must be kept to a maximum of 20 feet. If a 20 foot horizontal run is required, the fireplace must have a minimum vertical rise immediately off the fireplace of 57". When terminating vertically, the vertical rise is a minimum 3 feet and a maximum 40 feet above the fireplace.

**FIGURES 3a-b**



**FIGURE 4**



**HORIZONTAL VENT SECTIONS:** A minimum clearance of 2" all around the vent pipe on all horizontal runs to combustibles is required. Use firestop spacer W010-1799 (supplied).

**VERTICAL VENT SECTIONS:** A minimum of 1" all around the vent pipe on all vertical runs to combustibles is required except for clearances in fireplace enclosures. Use firestop spacer W500-0096 (not supplied).

## ! WARNING

\* The first 2 feet of outer 7" diameter vent pipe from the appliance must be wrapped in the 1" thick insulation sleeve (supplied). Make sure the insulation is pulled down tight to the fireplace when installed. There after, a 2" clearance all around the vent pipe from combustible materials on all horizontal vent sections is required.

**DEFINITIONS**

for the following symbols used in the venting calculations and examples are:

- > - greater than
- ≥ - equal to or greater than
- < - less than
- ≤ - equal to or less than

**H<sub>T</sub>** - total of both horizontal vent lengths (**H<sub>R</sub>**) and offsets (**H<sub>O</sub>**) in feet

**H<sub>R</sub>** - combined horizontal vent lengths in feet

**H<sub>O</sub>** - offset factor: .03 (total degrees of offset - 90°\*) in feet

**V<sub>T</sub>** - combined vertical vent lengths in feet

**ELBOW VENT LENGTH VALUES**

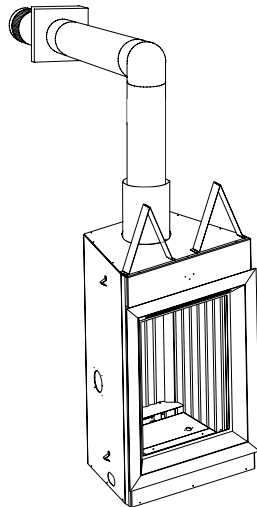
|      | feet | inches |
|------|------|--------|
| 1°   | 0.03 | 0.5    |
| 15°  | 0.45 | 6.0    |
| 30°  | 0.9  | 11.0   |
| 45°  | 1.35 | 16.0   |
| 90°* | 2.7  | 32.0   |

\* the first 90° offset has a zero value and is shown in the formula as -90°

**HORIZONTAL TERMINATION**

when (**H<sub>T</sub>**) ≤ (**V<sub>T</sub>**)

Simple venting configuration (only one 90° elbow)



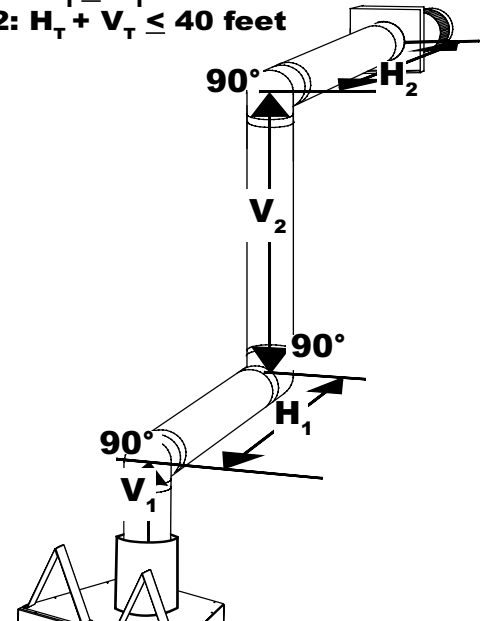
**FIGURE 5**

See graph to determine the required vertical rise **V<sub>T</sub>** for the required horizontal run **H<sub>T</sub>**.

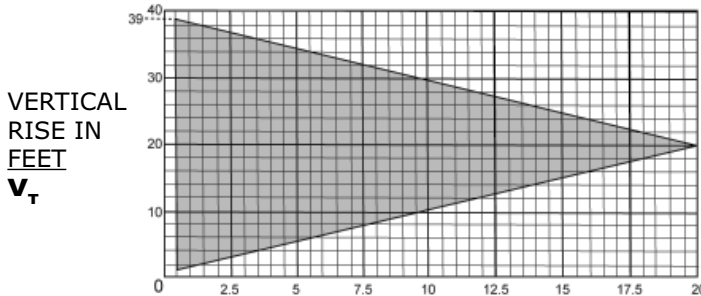
For vent configurations requiring more than one 90° elbow, the following formulas apply:

**Formula 1: H<sub>T</sub> ≤ V<sub>T</sub>**

**Formula 2: H<sub>T</sub> + V<sub>T</sub> ≤ 40 feet**



**FIGURE 6**



HORIZONTAL VENT RUN PLUS OFFSET IN FEET **H<sub>T</sub>**

The shaded area within the lines represents acceptable values for **H<sub>T</sub>** and **V<sub>T</sub>**.

**Example 1:**

**V<sub>1</sub>** = 3 ft

**V<sub>2</sub>** = 8 ft

**V<sub>T</sub>** = **V<sub>1</sub>** + **V<sub>2</sub>** = 3 + 8 = 11 ft

**H<sub>1</sub>** = 2.5 ft

**H<sub>2</sub>** = 2 ft

**H<sub>R</sub>** = **H<sub>1</sub>** + **H<sub>2</sub>** = 2.5 + 2 = 4.5 ft

**H<sub>O</sub>** = .03 (three 90° elbows - 90°) = .03(270° - 90°) = 5.4 ft

**H<sub>T</sub>** = **H<sub>R</sub>** + **H<sub>O</sub>** = 4.5 + 5.4 = 9.9 ft

**H<sub>T</sub> + V<sub>T</sub>** = 9.9 + 11 = 20.9 ft

Formula 1: **H<sub>T</sub> ≤ V<sub>T</sub>**  
9.9 ≤ 11

Formula 2: **H<sub>T</sub> + V<sub>T</sub> ≤ 40 feet**  
20.9 ≤ 40

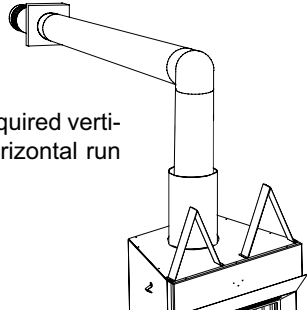
Since both formulas are met, this vent configuration is acceptable.

# HORIZONTAL TERMINATION

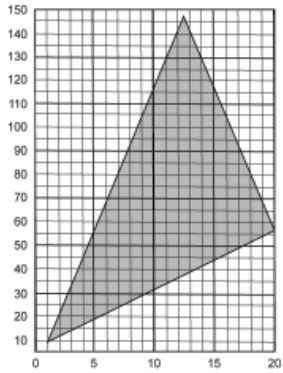
when  $(H_T) > (V_T)$   
 Simple venting configuration (only one 90° elbow)

**FIGURE 7**

See graph to determine the required vertical rise  $V_T$  for the required horizontal run  $H_T$ .



REQUIRED VERTICAL RISE IN INCHES  $V_T$

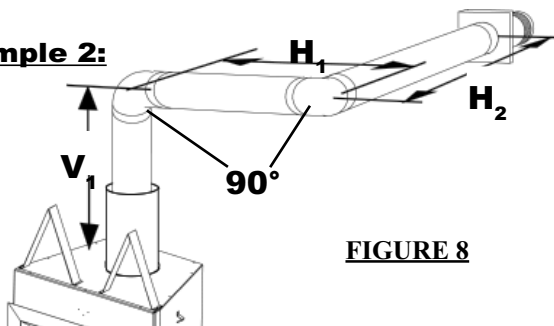


HORIZONTAL VENT RUN PLUS OFFSET IN FEET  $H_T$   
 The shaded area within the lines represents acceptable values for  $H_T$  and  $V_T$ .

For vent configurations requiring more than one 90° elbow the following formulas apply:

Formula 1:  $H_T \leq 4.2 V_T$   
 Formula 2:  $H_T + V_T \leq 24.75$  feet

**Example 2:**



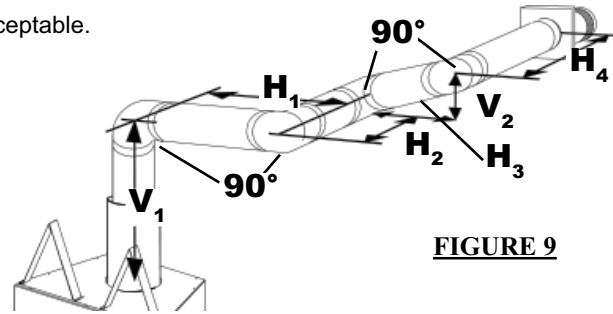
**FIGURE 8**

$$\begin{aligned} V_1 &= V_T = 6 \text{ ft} \\ H_1 &= 3 \text{ ft} \\ H_2 &= 5 \text{ ft} \\ H_R &= H_1 + H_2 = 3 + 5 = 8 \text{ ft} \\ H_0 &= .03 (\text{two } 90^\circ \text{ elbows} - 90^\circ) = .03(180^\circ - 90^\circ) = 2.7 \text{ ft} \\ H_T &= H_R + H_0 = 8 + 2.7 = 10.7 \text{ ft} \\ H_T + V_T &= 10.7 + 6 = 16.7 \end{aligned}$$

Formula 1:  $H_T \leq 4.2 V_T$   
 $4.2 V_T = 4.2 \times 6 = 25.2$   
 $10.7 \leq 25.2$

Formula 2:  $H_T + V_T \leq 24.75$  feet  
 $16.7 \leq 24.75$

Since both formulas are met, this vent configuration is acceptable.



**FIGURE 9**

**Example 3:**

$$\begin{aligned} V_1 &= 4 \text{ ft} \\ V_2 &= 1.5 \text{ ft} \\ V_T &= V_1 + V_2 = 4 + 1.5 = 5.5 \text{ ft} \\ H_1 &= 2 \text{ ft} \\ H_2 &= 1 \text{ ft} \\ H_3 &= 1 \text{ ft} \\ H_4 &= 1.5 \text{ ft} \\ H_R &= H_1 + H_2 + H_3 + H_4 = 2 + 1 + 1 + 1.5 = 5.5 \text{ ft} \\ H_0 &= .03 (\text{four } 90^\circ \text{ elbows} - 90^\circ) = .03(360^\circ - 90^\circ) = 8.1 \text{ ft} \\ H_T &= H_R + H_0 = 5.5 + 8.1 = 13.6 \text{ ft} \\ H_T + V_T &= 13.6 + 5.5 = 19.1 \text{ ft} \end{aligned}$$

Formula 1:  $H_T \leq 4.2 V_T$   
 $4.2 V_T = 4.2 \times 5.5 = 23.1$   
 $13.6 \leq 23.1$

Formula 2:  $H_T + V_T \leq 24.75$  feet  
 $19.1 \leq 24.75$

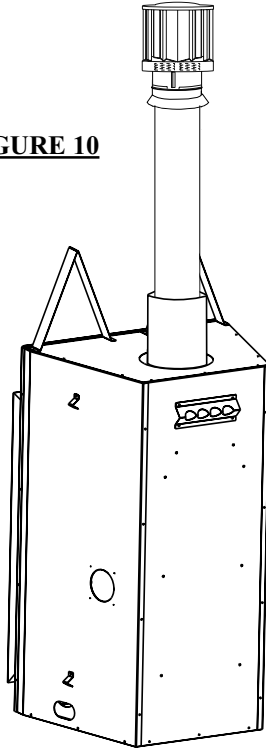
Since both formulas are met, this vent configuration is acceptable.



# VERTICAL TERMINATION

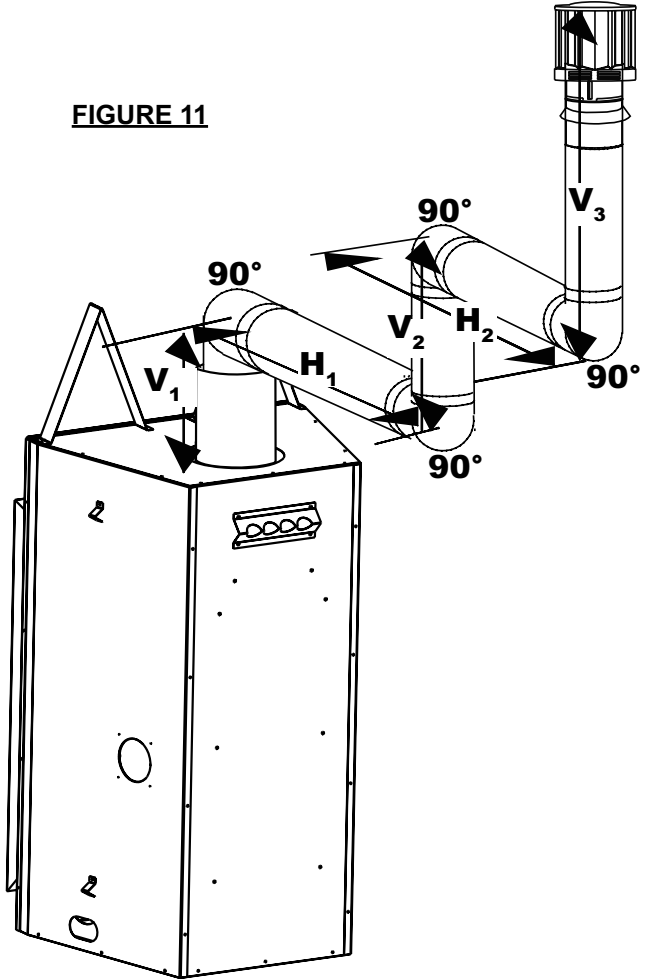
when  $(H_T) \leq (V_T)$

**FIGURE 10**

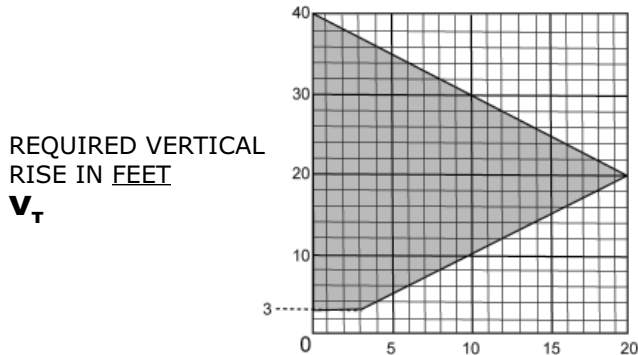


**Example 4:**

**FIGURE 11**



See graph to determine the required vertical rise  $V_T$  for the required horizontal run  $H_T$ .



HORIZONTAL VENT RUN PLUS OFFSET IN FEET  $H_T$

*The shaded area within the lines represents acceptable values for  $H_T$  and  $V_T$ .*

For vent configurations requiring more than zero 90° elbow (top exit) or one 90° elbow (rear exit), the following formulas apply:

- Formula 1:  $H_T \leq V_T$**
- Formula 2:  $H_T + V_T \leq 40$  feet**

- $V_1 = 5$  ft
- $V_2 = 6$  ft
- $V_3 = 10$  ft
- $V_T = V_1 + V_2 + V_3 = 5 + 6 + 10 = 21$  ft
- $H_1 = 8$  ft
- $H_2 = 2.5$  ft
- $H_R = H_1 + H_2 = 8 + 2.5 = 10.5$  ft
- $H_o = .03$  (four 90° elbows - 90°)
- $H_o = .03$  (90 + 90 + 90 + 90 - 90) = 8.1 ft
- $H_T = H_R + H_o = 10.5 + 8.1 = 18.6$  ft
- $H_T + V_T = 18.6 + 21 = 39.6$  ft

Formula 1:  $H_T \leq V_T$   
 $18.6 \leq 21$

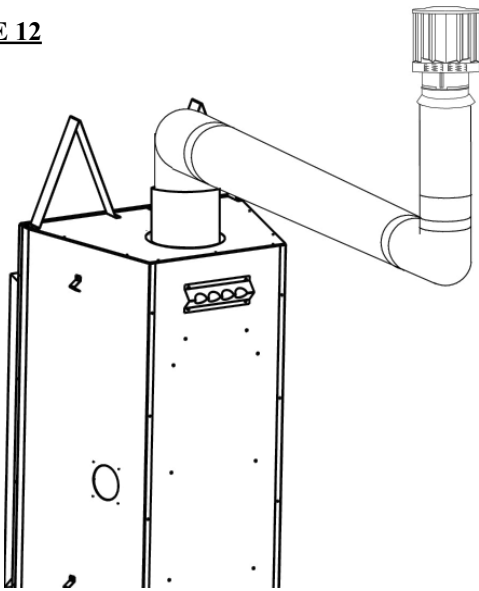
Formula 2:  $H_T + V_T \leq 40$  feet  
 $39.6 \leq 40$

Since both formulas are met, this vent configuration is acceptable.

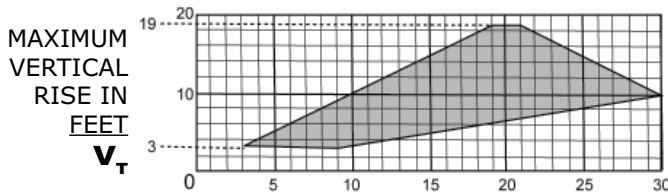
# VERTICAL TERMINATION

when  $(H_T) > (V_T)$

**FIGURE 12**



Simple venting configurations  
See graph to determine the required vertical rise  $V_T$  for the required horizontal run  $H_T$ .

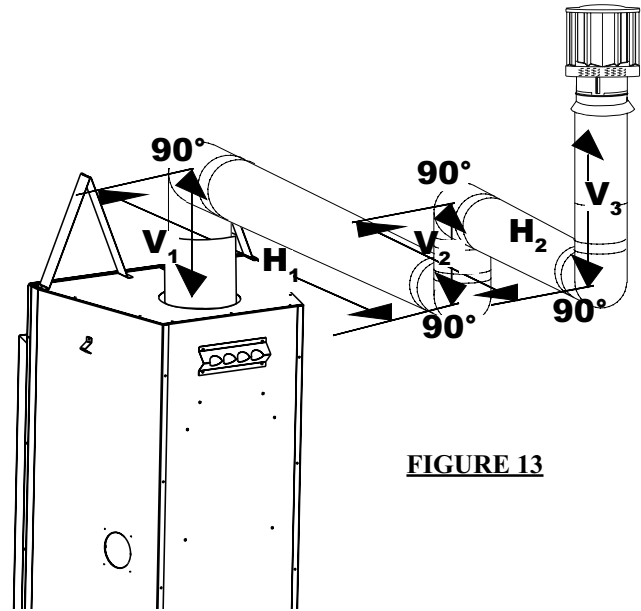


HORIZONTAL VENT RUN PLUS OFFSET IN FEET  $H_T$

*The shaded area within the lines represents acceptable values for  $H_T$  and  $V_T$ .*

For vent configurations requiring more than two 90° elbow (top exit) or one 90° elbow (rear exit), the following formulas apply:

- Formula 1:  $H_T \leq 3V_T$**
- Formula 2:  $H_T + V_T \leq 40$  feet**



**FIGURE 13**

**Example 5:**

- $V_1 = 2$  ft
- $V_2 = 1$  ft
- $V_3 = 1.5$  ft
- $V_T = V_1 + V_2 + V_3 = 2 + 1 + 1.5 = 4.5$  ft
- $H_1 = 6$  ft
- $H_2 = 2$  ft
- $H_R = H_1 + H_2 = 6 + 2 = 8$  ft
- $H_o = .03(\text{four } 90^\circ \text{ elbows} - 90^\circ)$
- $H_o = .03(90 + 90 + 90 + 90 - 90) = 8.1$  ft
- $H_T = H_R + H_o = 8 + 8.1 = 16.1$  ft
- $H_T + V_T = 16.1 + 4.5 = 20.6$  ft

Formula 1:  $H_T \leq 3V_T$   
 $3V_T = 3 \times 4.5 = 13.5$   
 $16.1 > 13.5$

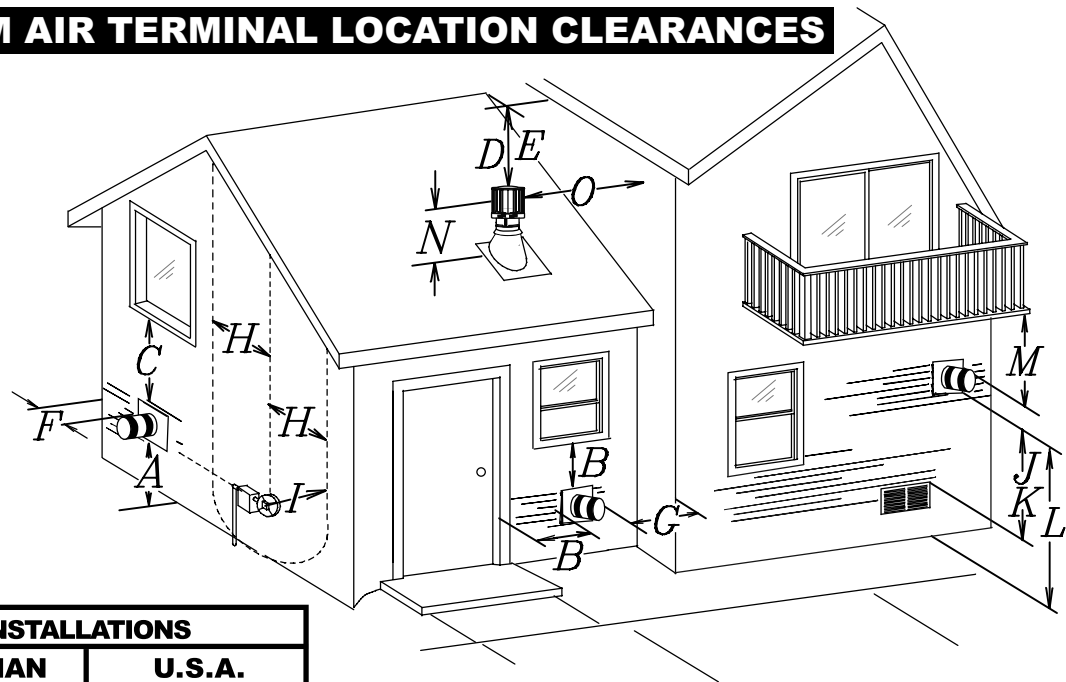
Since this formula is not met, this vent configuration is **unacceptable**.

Formula 2:  $H_T + V_T \leq 40$  feet  
 $20.6 \leq 40$

Since only formula 2 is met, this vent configuration is unacceptable and a new fireplace location or vent configuration will need to be established to satisfy both formulas.

## MINIMUM AIR TERMINAL LOCATION CLEARANCES

FIGURE 14



| INSTALLATIONS |             |               |  |
|---------------|-------------|---------------|--|
|               | CANADIAN    | U.S.A.        |  |
| <b>A</b>      | 12 INCHES   | 12 INCHES     | Clearance above grade, veranda porch, deck or balcony.   |
| <b>B</b>      | 12 INCHES   | 9 INCHES      | Clearance to windows or doors that open.   |
| <b>C</b>      | 12 INCHES*  | 12 INCHES*    | Clearance to permanently closed windows.   |
| <b>D</b>      | 18 INCHES** | 18 INCHES**   | Vertical clearance to ventilated soffit located above the terminal within a horizontal distance of 2 feet from the centerline of the terminal. |
| <b>E</b>      | 12 INCHES** | 12 INCHES**   | Clearance to unventilated soffit.  |
| <b>F</b>      | 0 INCHES    | 0 INCHES      | Clearance to an outside corner wall.   |
| <b>G</b>      | 0 INCHES*** | 0 INCHES***   | Clearance to an inside <i>non</i> -combustible corner wall or protruding <i>non</i> -combustible obstructions (chimney, etc.).                 |
|               | 2 INCHES*** | 2 INCHES***   | Clearance to an inside combustible corner wall or protruding combustible obstructions ( vent chase, etc.).                                     |
| <b>H</b>      | 3 FEET      | 3 FEET****    | Clearance to each side of the centerline extended above the meter / regulator assembly to a maximum vertical distance of 15ft.                 |
| <b>I</b>      | 3 FEET      | 3 FEET****    | Clearance to a service regulator vent outlet.  |
| <b>J</b>      | 12 INCHES   | 9 INCHES      | Clearance to a non-mechanical air supply inlet to the building or a combustion air inlet to any other appliance.                               |
| <b>K</b>      | 6 FEET      | 3 FEET†       | Clearance to a mechanical air supply inlet.  |
| <b>L</b>      | 7 FEET‡     | 7 FEET****    | Clearance above a paved sidewalk or paved driveway located on public property unless fitted with a heat shield kit GD-301.                     |
| <b>M</b>      | 12 INCHES†† | 12 INCHES**** | Clearance under a veranda, porch, deck or balcony.   |
| <b>N</b>      | 16 INCHES   | 16 INCHES     | Clearance above the roof.  |
| <b>O</b>      | 2 FEET†*    | 2 FEET†*      | Clearance from an adjacent wall including neighbouring buildings.  |

\* Recommended to prevent condensation on windows and thermal breakage

\*\* It is recommended to use a heat shield and to maximize the distance to vinyl clad soffits.

\*\*\* The periscope GD-201 requires a minimum 18 inches clearance from an inside corner.

\*\*\*\* This is a recommended distance. For additional requirements check local codes.

† 3 feet above if within 10 feet horizontally.

‡ A vent shall not terminate directly above a sidewalk or paved driveway that is located between two single family dwellings and serves both dwellings.

†† Permitted only if the veranda, porch, or deck is fully open on a minimum of two sides beneath the floor.

†\* Recommended to prevent recirculation of exhaust products. For additional requirements check local codes.

# INSTALLATION

## WALL AND CEILING PROTECTION

**HORIZONTAL VENT SECTIONS:** A minimum clearance of 2" all around the vent pipe on all horizontal runs to combustibles is required. Use firestop spacer W010-1799 (supplied).

**VERTICAL VENT SECTIONS:** A minimum of 1" all around the vent pipe on all vertical runs to combustibles is required except for clearances in fireplace enclosures. Use firestop spacer W500-0096 (not supplied).

### HORIZONTAL INSTALLATION

This application occurs when venting through an exterior wall. Having determined the correct height for the air terminal location, cut and frame a hole in the exterior wall 11 3/4" wide by 11 3/4" high to accommodate the firestop assembly. Dry fit the firestop assembly before proceeding to ensure the brackets on the rear surface fit within the horizontal framing. As an alternative to framing, the vent pipe can be enclosed in the wall using Napoleon® vent sleeve VS47KT.

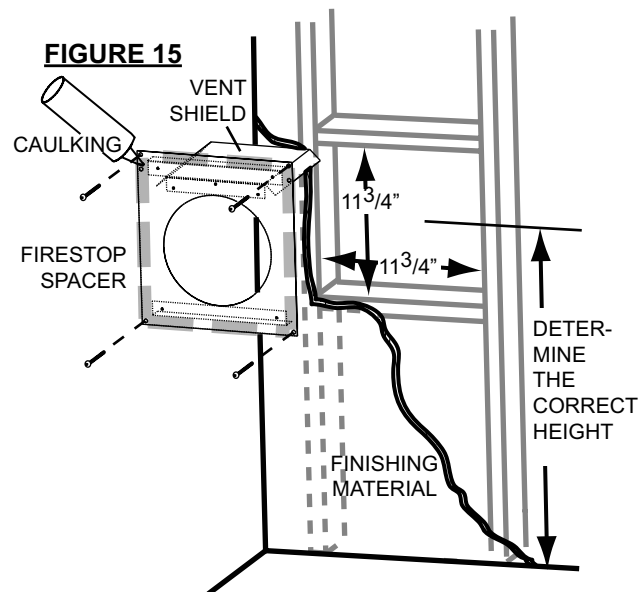
**NOTE: THE FIRESTOP ASSEMBLY MUST BE INSTALLED WITH THE VENT SHIELD TO THE TOP.**

The length of the vent shield may be cut shorter for combustible walls that are less than 8 1/2" thick but the vent shield must extend the full depth of the combustible wall.

1. Apply a bead of caulking (not supplied) around the outer edge of the inside surface of the firestop assembly, fit the firestop assembly to the hole and secure using the 4 screws W415-0026 (supplied in your manual baggie).

2. Once the vent pipe is installed in its final position, apply high temperature sealant W573-0002 (not supplied) between the pipe / liner, and the firestop.

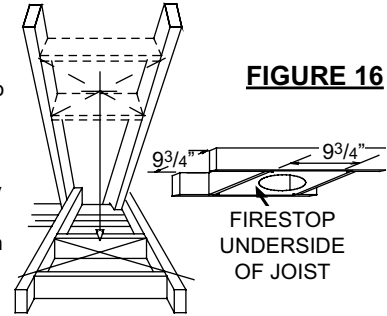
**NOTE: DO NOT FILL THE CAVITY BETWEEN THE PIPE AND THE FIRESTOP SLEEVE WITH ANY TYPE OF MATERIAL.**



**FIGURE 15**

### VERTICAL INSTALLATION

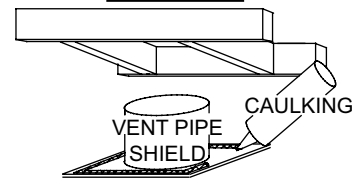
1. Determine the air terminal location, cut and frame 9 3/4" openings in the ceiling and the roof to provide the minimum 1" clearance between the vent pipe and any combustible material. Try to center the vent pipe location midway between two joist to prevent having to cut them. Use a plumb bob to line up the center of the openings. Do not fill this space with any type of material.



**FIGURE 16**

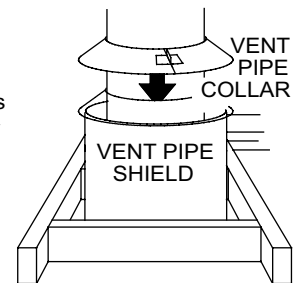
A vent pipe shield will prevent any materials such as insulation, from filling up the 1" air space around the pipe. Nail headers between the joist for extra support.

2. Apply a bead of caulking (not supplied) to the framework or to the Wolf Steel vent pipe shield plate or equivalent (in the case of a finished ceiling), and secure over the opening in the ceiling. A firestop must be placed on the bottom of each framed opening in a roof or ceiling that the venting system passes through. Apply a bead of caulking (not supplied) all around and place a firestop spacer over the vent shield to restrict cold air from being drawn into the room or around the fireplace. Ensure that both spacer and shield maintain the required clearance to combustibles. Once the vent pipe is installed in its final position, apply sealant between the vent pipe and the firestop spacer.



**FIGURE 17**

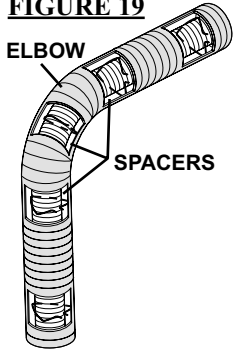
3. In the attic, slide the vent pipe collar down to cover up the open end of the shield and tighten. This will prevent any materials, such as insulation, from filling up the 1" air space around the pipe.



**FIGURE 18**

# USING FLEXIBLE VENT COMPONENTS

**FIGURE 19**



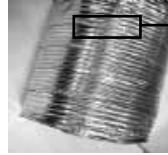
## ! WARNING

Do not allow the inside vent pipe to bunch up on horizontal or vertical runs and elbows. Keep it pulled tight. A 1 1/4" air gap between the liner and the outer liner all around is required for safe operation. A spacer is required at the start, middle and end of each elbow to ensure this gap is maintained. Spacers are attached to the inner flexible vent pipe at predetermined intervals to maintain a 1 1/4" air gap to the outer flexible vent pipe. These spacers must not be removed.

For safe and proper operation of the fireplace, follow the venting instructions exactly.

All inner exhaust and outer intake vent pipe joists may be sealed using either red RTV high temp silicone sealant or black high temp Mill Pac with the exception of the fireplace exhaust flue collar which must be sealed using Mill Pac (not supplied).

Use only approved flexible vent pipe kits marked:



"Wolf Steel Approved Venting" as identified by the stamp only on the 7" outer vent pipe.

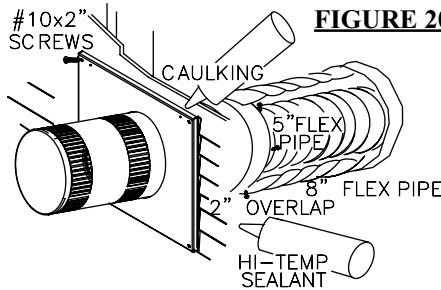
Six inches (6") is the minimum bend radius allowed for the seven inch (7") diameter flexible vent pipe.

For optimum performance it is recommended that all horizontal runs have a minimum 1" rise per foot using flexible venting.

## HORIZONTAL AIR TERMINAL INSTALLATION

Note: Direct vent terminals shall not be recessed into a wall or siding.

1. Stretch the 4" diameter flexible vent pipe to the required length taking into account the additional length needed for the finished wall surface. Slip the liner a minimum of 2" over the inner sleeve of the air terminal and secure with 3 #8 screws. Apply a heavy bead of the high temperature sealant W573-0007 (not supplied).

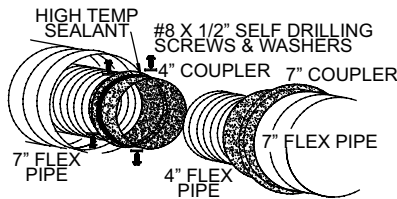


**FIGURE 20**

2. Using the 7" diameter flexible vent pipe, slide over the outer combustion air sleeve of the air terminal and secure with 3 #8 screws. Seal as before.

3. Insert the vent pipe through the firestop maintaining the required clearance to combustibles. Secure to the exterior wall and make weather tight by sealing with caulking W573-0002 (not supplied).

4. If more vent pipe needs to be used to reach the fireplace, couple them together as illustrated in (Fig. 20). The vent system must be supported approximately every 3 feet for both vertical and horizontal runs. Use non-combustible strapping to maintain the minimum 1" clearance to combustibles.



**FIGURE 21**

## VERTICAL AIR TERMINAL INSTALLATION

1. Move the fireplace into position.

2. Fasten the roof support to the roof using the screws provided. The roof support is optional. In this case the venting is to be adequately supported using either an alternate method suitable to the authority having jurisdiction or the optional roof support.

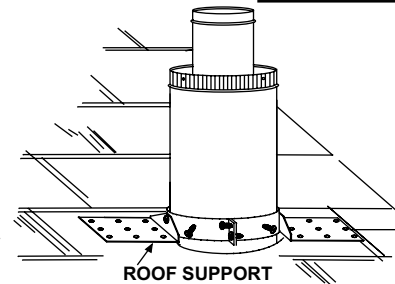
3. Stretch the inner flexible vent pipe to the required length. Slip the liner a minimum of 2" over the inner vent pipe of the air terminal connector and secure with 3 #8 screws. Seal using a heavy bead of the high temperature sealant W573-0007 (not supplied).

4. Repeat using the outer flexible vent pipe.

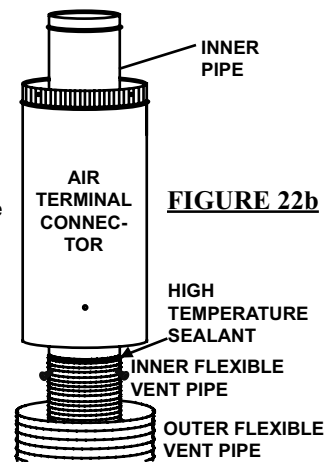
5. Thread the air terminal connector / pipe assembly down through the roof. The air terminal must be located vertically and plumb. Attach the air terminal connector to the roof support, ensuring that the top of the air terminal is 16" above the highest point that it penetrates the roof. **If the attic space is tight, we recommend threading the Wolf Steel vent pipe collar or equivalent loosely onto the air terminal assembly as it is passed through the attic.**

6. Remove nails from the shingles, above and to the sides of the chimney. Place the flashing over the air terminal connector leaving a min. 3/4" of the air terminal connector showing above the top of the flashing. Slide the flashing underneath the sides and upper edge of the shingles. Ensure that the air terminal connector is properly centred within the flashing, giving a 3/4" margin all around. Fasten to the roof. Do not nail through the lower portion of the flashing. Make weather-tight by sealing with caulking. Where possible, cover the sides and top edges of the flashing with roofing material.

**FIGURE 22a**



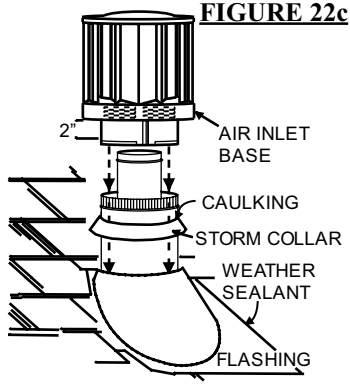
**FIGURE 22b**



**DO NOT CLAMP THE FLEXIBLE VENT PIPE**

7. Aligning the seams of the terminal and air terminal connector, place the terminal over the air terminal connector making sure the liner goes into the hole in the terminal. Secure with the three screws provided.

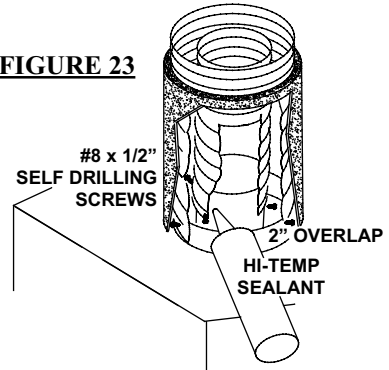
8. Apply a heavy bead of weatherproof caulking 2" above the flashing. **NOTE:** Maintain a minimum 2" space between the air inlet base and the storm collar. Install the storm collar around the air terminal connector and slide down to the caulking. Tighten to ensure that a weather-tight seal between the air terminal connector and collar is achieved.



**FIREPLACE VENT CONNECTION**

1. Install the 4" diameter flexible vent pipe to the fireplace. Secure with 3 screws and flat washers. Seal the joint and screw holes using the high temperature sealant W573-0007 (not supplied).
2. Install the 7" diameter flexible vent pipe to the fireplace. Attach and seal the joints using high temperature sealant W573-0002 (not supplied).

**FIGURE 23**

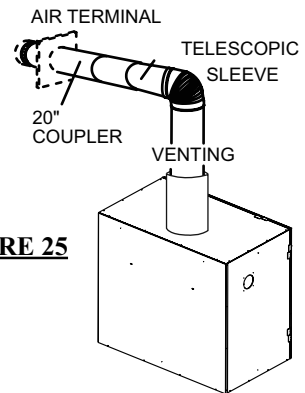


**USING RIGID VENT COMPONENTS**

The vent system must be supported approximately every 3 feet for both vertical and horizontal runs. Use Wolf Steel vent spacers or equivalent every 3 feet and either side of each elbow to maintain the minimum 1 1/4" clearance between the outer and inner vent pipes. Use Wolf Steel support ring assembly or equivalent noncombustible strapping to maintain the minimum clearance to combustibles for both vertical and horizontal runs.

**All inner exhaust and outer intake vent pipe joists may be sealed using either red RTV high temp silicone sealant or black high temp Mill Pac with the exception of the fireplace exhaust flue collar which must be sealed using Mill Pac (not supplied).**

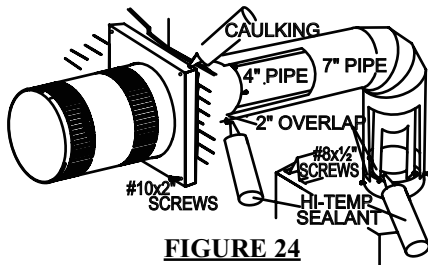
3. Install the air terminal. See item 3 of the Horizontal Air Terminal Installation. Extend the 4" telescopic sleeve; connect to the air terminal assembly. Fasten with self tapping screws and seal. Repeat using the 7" telescopic sleeve.



**FIGURE 25**

**HORIZONTAL AIR TERMINAL INSTALLATION**

1. Move the fireplace into position. Measure the vent length required between terminal and fireplace taking into account the additional length needed for the finished wall surface and any 1 1/4" overlaps between venting components.



**FIGURE 24**

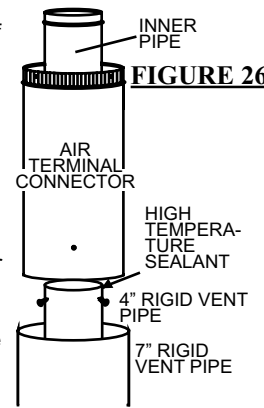
2. Apply high temperature sealant W573-0007 (not supplied) to the outer edge of the 4" inner collar of the fireplace. Attach the first vent component and secure using 3 self tapping screws. Repeat using 7" piping.
3. Holding the air terminal insert the terminal into both vent pipes with a twisting motion to ensure that both the terminal sleeves engage into the vent pipes and sealant. Secure the terminal to the exterior wall and make weather tight by sealing with caulking W573-0002 (not supplied).

**EXTENDED HORIZONTAL AIR TERMINAL INSTALLATION**

1. Follow the instructions for "Horizontal Air Terminal Installations", items 1 to 3.
2. Continue adding components alternating inner and outer venting. Ensure that all 4" venting and elbows have sufficient vent spacers attached and each component is securely fastened to the one prior. Attach the 4" telescopic sleeve to the vent run. Repeat using a 7" telescopic sleeve. Secure and seal as before. To facilitate completion, attach 4" and 7" couplers to the air terminal.

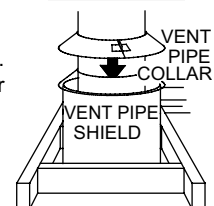
**VERTICAL VENTING INSTALLATION**

1. Move the fireplace into position.
2. Fasten the roof support to the roof using the screws provided. The roof support is optional. In this case the venting is to be adequately supported using either an alternate method suitable to the authority having jurisdiction or the optional roof support.
3. Apply high temperature sealant W573-0007 (not supplied) to the outer edge of the inner pipe of the air terminal connector. Slip a 4" diameter coupler a minimum of 2" over the pipe and secure using 3 screws.
4. Apply high temperature sealant W573-0007 (not supplied) to the outer edge of the of the outside pipe of the air terminal connector. Slip a 7" diameter coupler over the pipe and secure as before. Trim the 7" coupler even with the 4" coupler end.
5. Thread the air terminal pipe assembly down through the roof support and attach, ensuring that a minimum 16" of air terminal will penetrate the roof when fastened. If the attic space is tight, we recommend threading the Wolf Steel vent pipe collar or equivalent loosely onto the air terminal assembly as it is passed through the attic. The air terminal must be located vertically and plumb.



**FIGURE 26**

**FIGURE 27**



6. Remove nails from the shingles, above and to the sides of the chimney. Place the flashing over the air terminal and slide it underneath the sides and upper edge of the shingles. Ensure that the air terminal is properly centered within the flashing, giving a 3/4" margin all around. Fasten to the roof. Do NOT nail through the lower portion of the flashing. Make weather-tight by sealing with caulking. Where possible, cover the sides and top edges of the flashing with roofing material.

7. Aligning the seams of the terminal and air terminal connector, place the terminal over the air terminal connector making sure the liner goes into the hole in the terminal. Secure with the three screws provided. **Figure 22c**

8. Apply a heavy bead of weather-proof caulking 2" above the flashing. NOTE: Maintain a minimum 2" space between the air inlet base and the storm collar. Install the storm collar around the air terminal connector and slide down to the caulking. Tighten to ensure that a weather-tight seal between the air terminal connector and collar is achieved.

9. Continue adding rigid venting sections, sealing and securing as above. Attach a 4" collapsed telescopic sleeve to the last section of rigid piping. Secure with screws and seal. Repeat using a 7" telescopic sleeve.

10. Run a bead of high temperature sealant W573-0007 (not supplied) around the outside of the 4" collar on the fireplace. Pull the telescopic sleeve a minimum of 2" onto the collar. Secure with 3 screws. Repeat with the 7" telescopic sleeve.

11. In the attic, slide the vent pipe collar down to cover up the open end of the shield and tighten. This will prevent any materials, such as insulation, from filling up the 1" air space around the pipe. **Figure 27**

## MOBILE HOME INSTALLATION

This appliance is certified to be installed as an OEM (Original Equipment Manufacturer) installation in a manufactured home or mobile home and must be installed in accordance with the manufacturer's instructions and the Manufactured Home Construction and Safety Standard, Title 24 CFR, Part 3280, in the United States or the Mobile Home Standard, CAN/CSA Z240 MH Series, in Canada. This appliance is only for use with the type(s) of gas indicated on the rating plate. A conversion kit is supplied with the mobile home appliance.

This Mobile/Manufactured Home Listed appliance comes factory equipped with a means to secure the unit. The fireplace is equipped with two 1/4" diameter holes located in the front left and right corners of the base. For mobile home installations, the fireplace must be fastened in place. Use #10 hex head screws, inserted through the holes in the base to secure. Always turn off the pilot and the fuel supply at the source, prior to moving the mobile home.

After moving the mobile home and prior to lighting the fireplace, ensure that the logs are positioned correctly.

This appliance is certified to be installed in an aftermarket permanently located, manufactured (mobile) home, where not prohibited by local codes.

This fireplace is only for use with the type of gas indicated on the rating plate. This fireplace is not convertible for use with other gases, unless a certified kit is used.

### Conversion Kits

The mobile home appliance is field convertible between Natural Gas (NG) and Propane (LP). To convert from one gas to another consult your Napoleon dealer/distributor.

## GAS INSTALLATION

Proceed once the vent installation is complete.

NOTE: All gas connections must be contained within the fireplace when complete.

1. Move the fireplace into position and secure to the floor through the 1/4" holes located at either side of the base.
2. The fireplace is designed to accept 3/8" gas supply line. The fireplace is equipped with a 3/8" manual shut-off valve.
3. Connect the gas supply in accordance to local codes. In the absence thereof, install according to the National Installation Code.

4. When flexing any gas line, support the gas valve so that the lines are not bent or kinked.

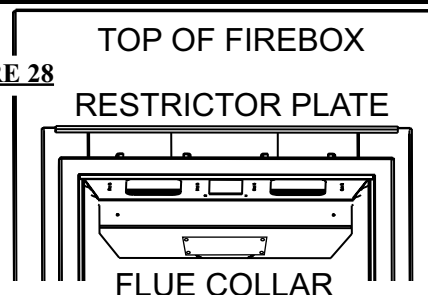
5. Check for gas leaks by brushing on a soap and water solution.

Do not use open flame.

Purge all gas lines with the glass door of the stove removed. Assure that a continuous gas flow is at the burner before re-installing the door.

## RESTRICTING VERTICAL VENTS

FIGURE 28

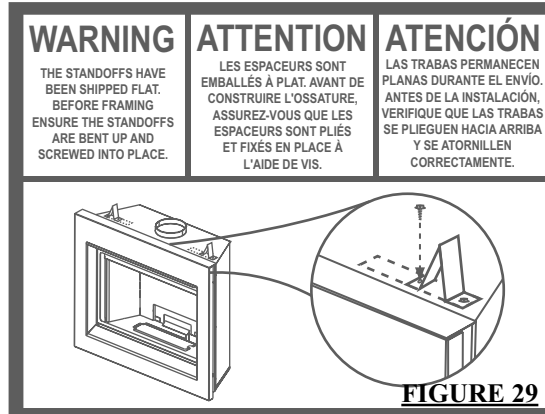


Vertical terminations may display a very active flame. If this appearance is not desirable, the vent exit must be restricted using restrictor plate, W500-0205. This reduces the velocity of the exhaust gases, slowing down the flame pattern and creating a more traditional appearance.

The plate has a series of holes to allow for adjustment. Remove the two screws on either side of the exhaust collar inside the firebox. Install the plate in the desired set of holes, then replace the screws.

It is recommend to secure in the third set of holes which causes the greatest amount of restriction for vent length between 15 and 30 feet.

## MINIMUM FRAMING CLEARANCES



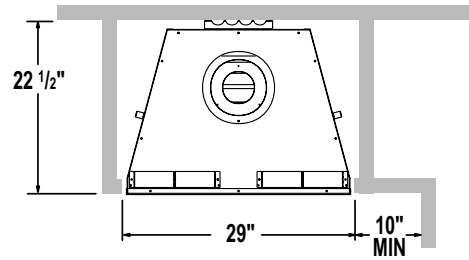
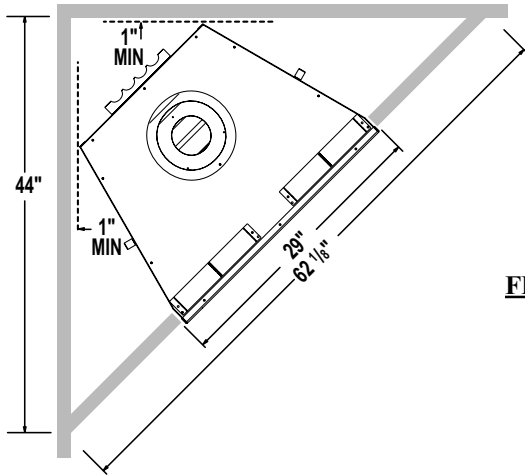
It is best to frame your fireplace after it is positioned and the vent system is installed. Use 2x4's and frame to local building codes.

**NOTE:** In order to avoid the possibility of exposed insulation or vapour barrier coming in contact with the fireplace body, it is recommended that the walls of the fireplace enclosure be "finished" (ie: drywall/sheetrock), as you would finish any other outside wall of a home. This will ensure that clearance to combustibles is maintained within the cavity.

For convenience, the stand-offs have been shipped flat. Before framing, ensure the stand-offs are opened and screwed in place. It is not necessary to install a hearth extension, but the fireplace should be raised to be flush with either the hearth or the finished floor.

When roughing in the fireplace, raise the fireplace to accommodate for the thickness of the finished floor materials, i.e. tile, carpeting, hard wood.

Objects placed in front of the fireplace should be kept a minimum of 48" away from the front face.

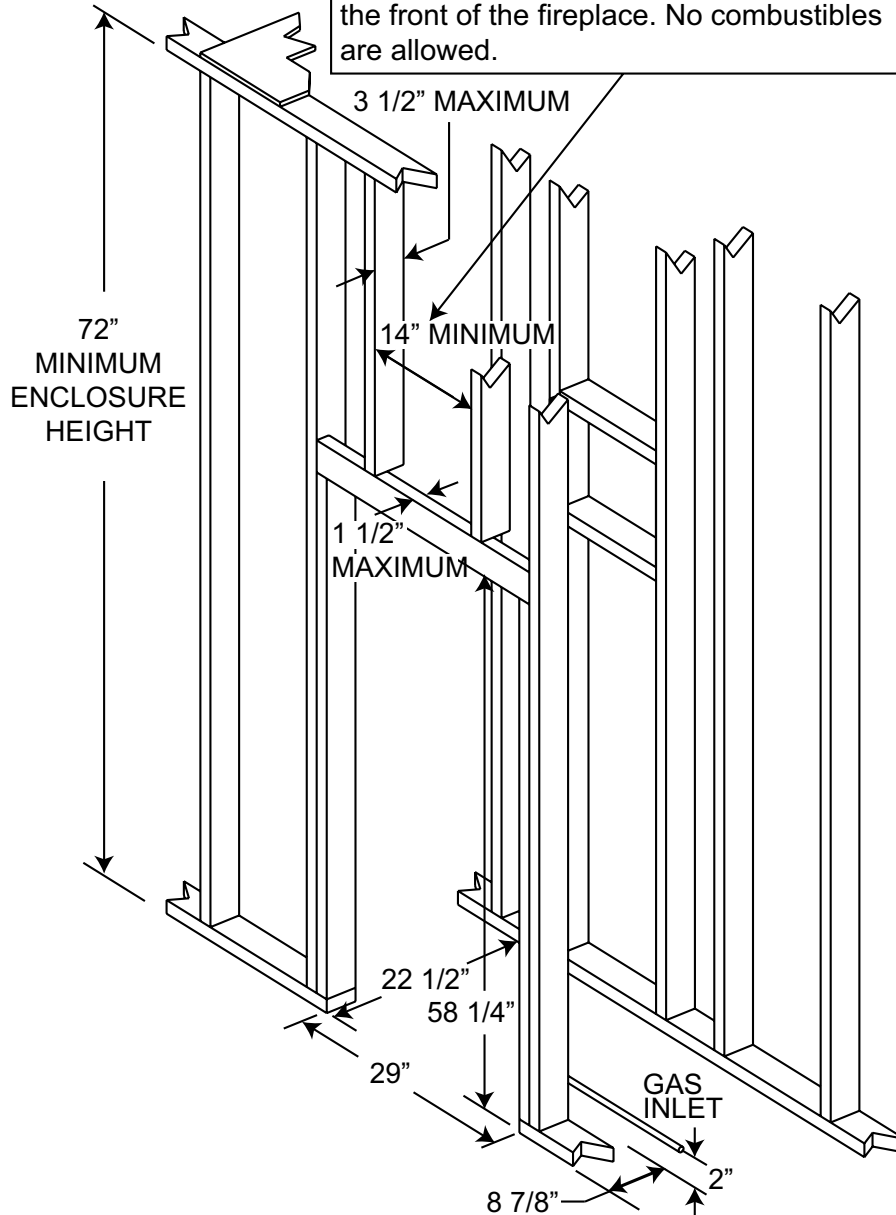


**FIGURE 30a-b**

**! WARNING**

Do not build into this area - it must be left clear to provide adequate clearance for the vent in this 14" wide area centered along the front of the fireplace. No combustibles are allowed.

**FIGURE 31**





## MINIMUM ENCLOSURE CLEARANCES

**Minimum clearance to combustible construction from fireplace and vent surfaces:**

**Combustible framing:**

- 0" to stand-offs

**Non-combustible fireplace finishing:**

- 4" from the sides of fireplace opening
- 22 <sup>3</sup>/<sub>8</sub>" to the top of fireplace opening

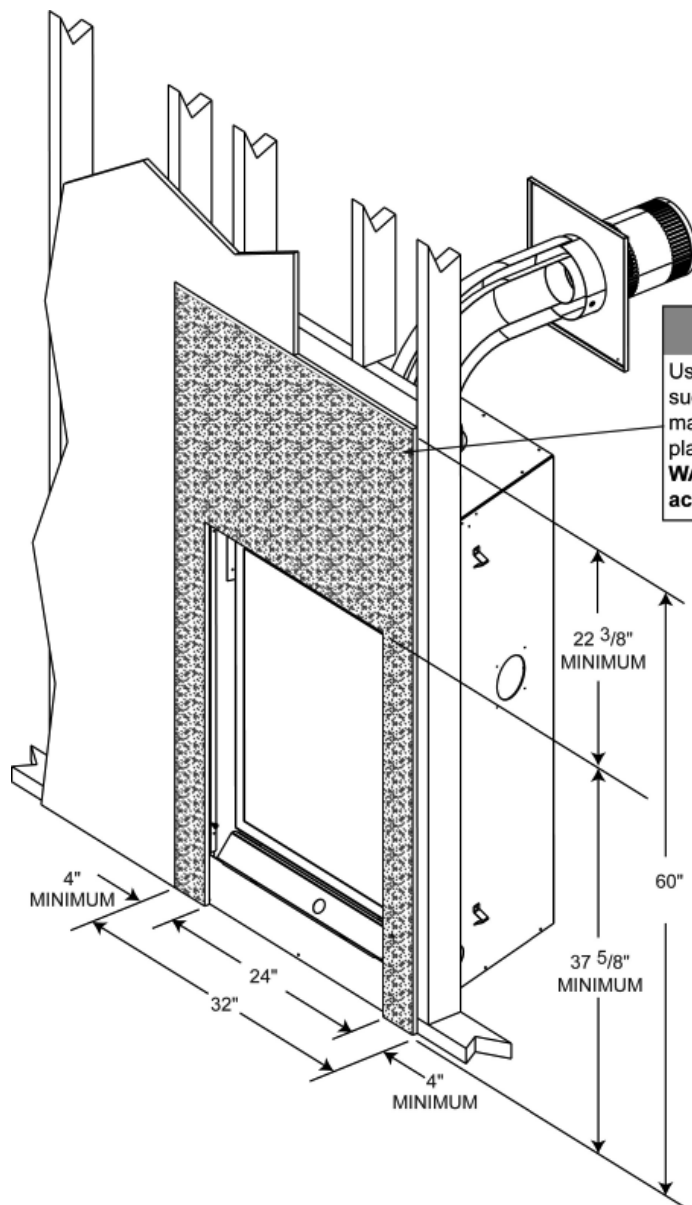
**Combustible fireplace finishing:**

- 0" to rear and sides
- 2" all around the vent pipe
- 22 <sup>1</sup>/<sub>2</sub>" recessed depth
- 72" from bottom of unit to enclosure top
- 72" from bottom of unit to ceiling

**HORIZONTAL VENT SECTIONS:** A minimum clearance of 2" all around the vent pipe on all horizontal runs to combustibles is required. Use firestop spacer W010-1799 (supplied).

**VERTICAL VENT SECTIONS:** A minimum of 1" all around the vent pipe on all vertical runs to combustibles is required except for clearances in fireplace enclosures. Use firestop spacer W500-0096 (not supplied).

**FIGURE 32**



### ! WARNING

Use only non-combustible material such as cement board, ceramic tile, marble, etc. when finishing to the fireplace. **DO NOT USE WOOD OR DRY-WALL.** Any fire rated drywall is not acceptable.

### ! WARNING

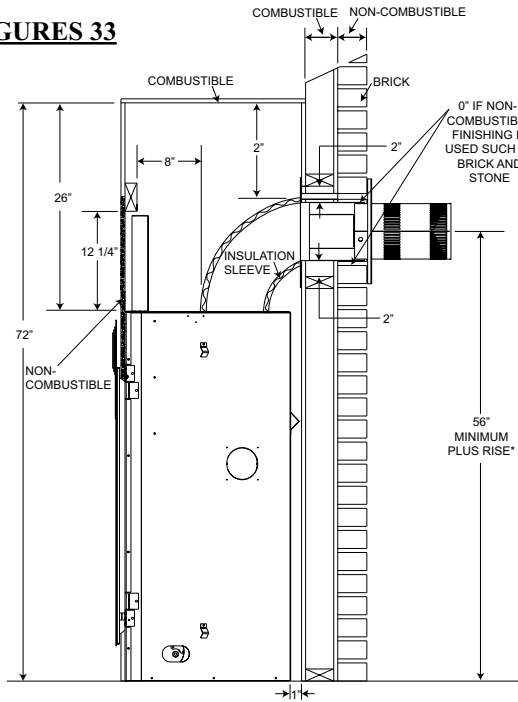
**Facing and/or finishing material must never overhang into the fireplace opening. Do not distort or force the frame kit components.**

**When using a rough finish material (i.e.; stone), maintain a <sup>1</sup>/<sub>4</sub>" - <sup>1</sup>/<sub>2</sub>" border from the framing components.**

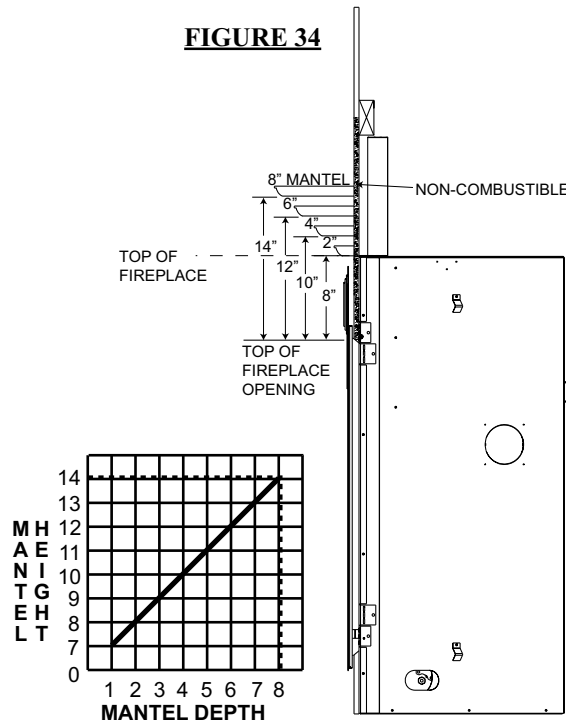
## MINIMUM MANTEL AND ENCLOSURE CLEARANCES

Combustible mantel clearance can vary according to the mantel depth. Use the graph to help evaluate the clearance needed.

**FIGURES 33**



**FIGURE 34**



**FIGURE 35**

**IMPORTANT:**

The *Park Avenue* requires a minimum inside enclosure height of 72".

For temperature requirements, the enclosure space around and above the fireplace must be left unobstructed.

\* See venting section

## ELECTRICAL CONNECTION

Do NOT use the fireplace if any part has been under water. Call a qualified service technician IMMEDIATELY to have the fireplace inspected for damage to the electrical circuit.

If access to the control area is necessary **BEFORE INSTALLATION**, remove the access panel.

The access panel must be re-installed before operating the unit.

### HARD WIRING CONNECTION

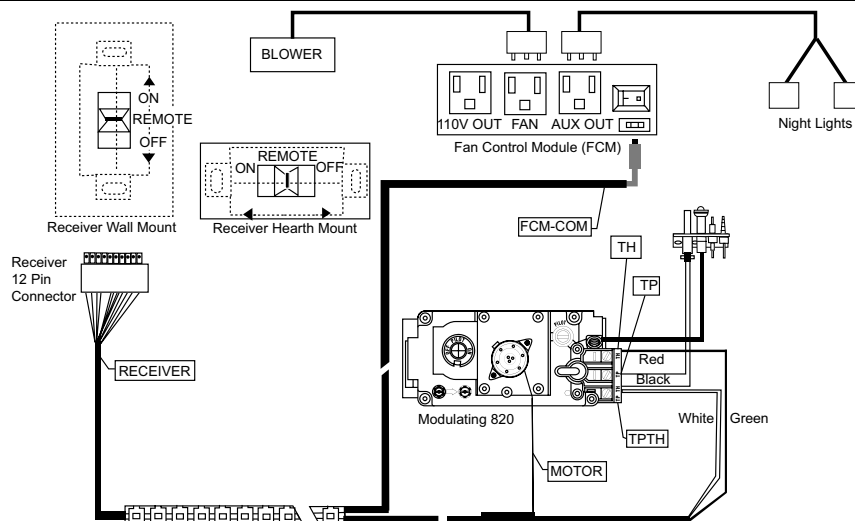
It is necessary to hard wire this fireplace.

Permanently framing the fireplace with an enclosure, requires the fireplace junction box to be hardwired.

This fireplace must be electrically connected and grounded in accordance with local codes. In the absence of local codes, use the current CSA C22.1 CANADIAN ELECTRICAL CODE in Canada or the ANSI/NFPA 70-1996 NATIONAL ELECTRICAL CODE in the United States.

## ELECTRICAL SCHEMATIC

**FIGURE 36**



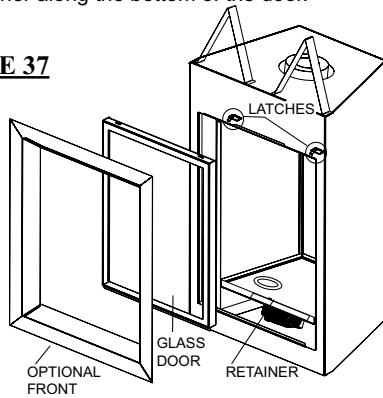
# FINISHING

## DOOR REMOVAL

Before the glass door can be removed, the optional front must be removed.

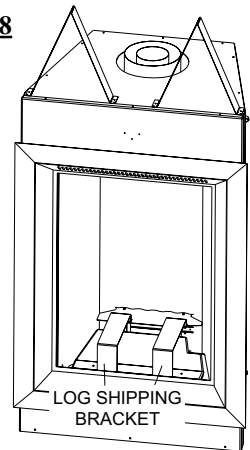
The glass door is secured to the top front edge of the firebox with two latches. Pull the handles of the latches forward, then lift the hooks out from the slots in the door frame to release the top of the door. Next, pivot forward until the top edge of the door clears the front of the fireplace. Next gripping the sides of the door lift the door out from the retainer along the bottom of the door.

**FIGURE 37**



## LOG SHIPPING BRACKET

**FIGURE 38**



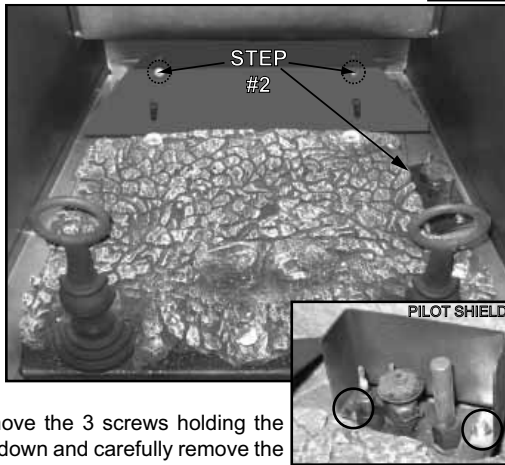
Before installing the logs, you must first remove the log shipping brackets. Lift up to remove.

## DECORATIVE BRICK PANEL INSTALLATION

Decorative panels may discolor after time.

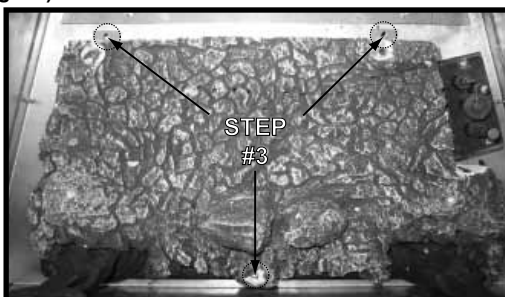
1. Carefully remove the glass door and all logs. (Refer to the "FINISHING" section)

2. Remove the two screws holding the front portion of the rear air deflector. Remove the pilot shield by removing the two screws as illustrated. **(Fig. 40)**



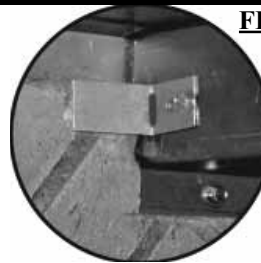
3. Remove the 3 screws holding the burner down and carefully remove the burner. **(Fig. 41)**

4. Install the right brick panel by sliding the bottom edge of the panel down the right firebox side then pivot the top edge of the panel into place against the firebox wall. Hold in place with the brick retainers. **(Fig. 41)**



**FIGURE 41**

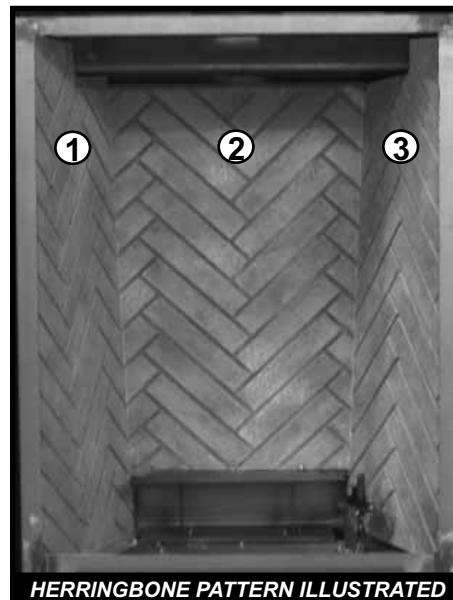
**FIGURE 42**



5. Rest the bottom edge of the rear panel on top of the rear portion of the air deflector at the back of the firebox and push into place. The rear panel is held in place when both side panels are in position.

6. Install the left brick panel using the same method described in step 4.

7. Replace the burner, air deflector, logs and glass door.



**FIGURE 43**

*Note: Due to the brittle material of the bricks, care must be taken not to bend or force them into place.*

*Note: Refractory panels require a 24 hour curing period on a low flame.*

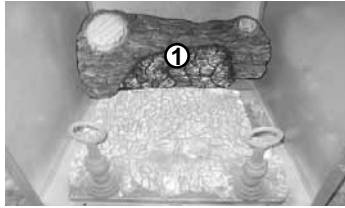
## LOG PLACEMENT

**NOTE:** Decorative brick panels must be installed before the logs.  
See installation instructions supplied with the panel kit.

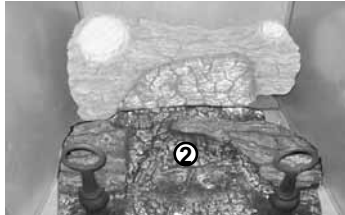
PHAZER™ logs, exclusive to Napoleon® Fireplaces, provide a unique and realistic glowing effect that is different in every installation.

**FIGURE 39 a-f**

1. Place the rear log #1 onto the locating studs along the back edge of the PHAZERAM-IC™ burner.



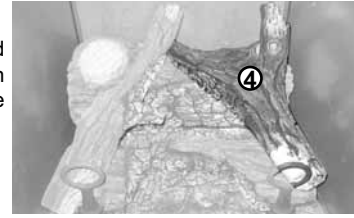
2. Position log #2 in the 2 locating holes behind the andirons.



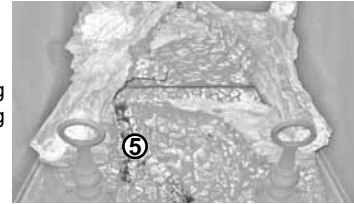
3. Place log #3, with the charred branch facing inward. Position the pin in log #3 into the hole on the left of the log #2.



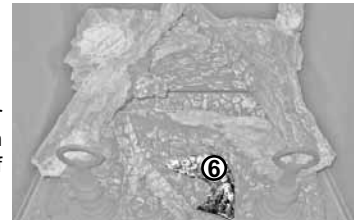
4. Place log #4 with the charred branch facing inward. Position the pin in log #4 into the hole on the right of log #2.



5. Place log #5 so the locating hole on the bottom of the log sits on the screw and spacer.



6. Finally, align the rectangular peg on log #6 with the notch on the front right portion of the burner.



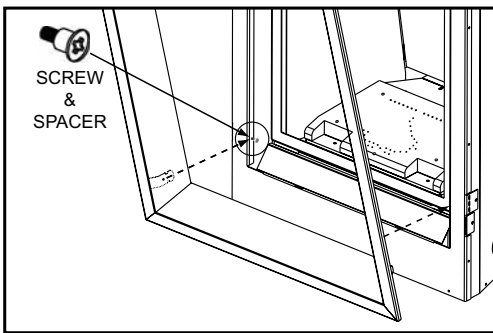
### GLOWING EMBERS

Glowing embers are NOT recommended. The burner has been designed to achieve maximum glow without embers.

## AFK / WI FACE KIT INSTALLATION

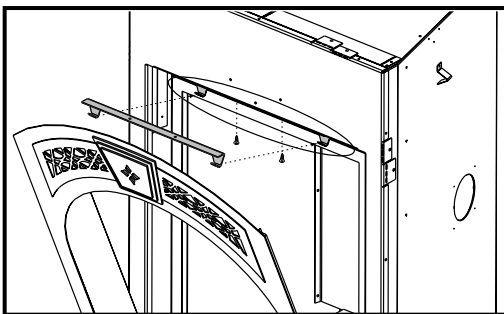
1. Attach screw and spacer as illustrated in (Fig. 44) to the bottom of both sides of the front housing.

**FIGURE 44**



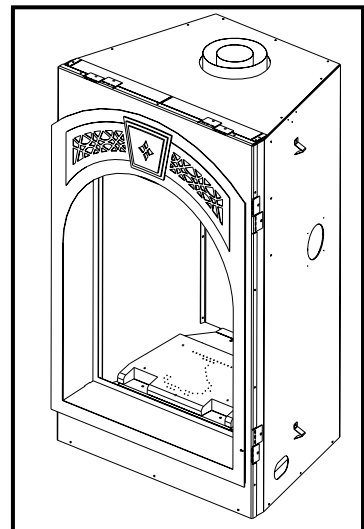
2. Attach the face plate bracket provided to the top edge of the front housing using 2 #8 - 1/2" truss head screws as illustrated in (Fig. 45).

**FIGURE 45**

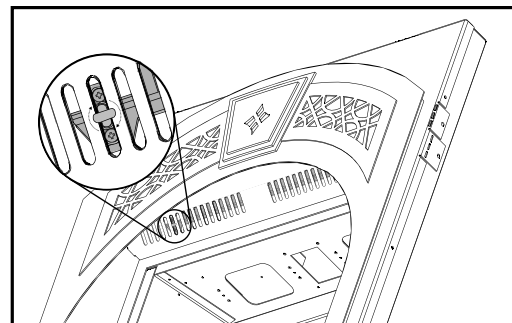


**FIGURE 46**

3. Lift and hook the faceplate over the spacers, and push the top of the faceplate back until it comes in contact with the base of the turn button. To secure the faceplate simply turn the head of the turn button to the horizontal position. (Fig. 47).



**FIGURE 47**



**NOTE:** A 1/4" gap must be maintained between the front and all finishing material due to regular removal.

# SERVICING / REPLACEMENTS

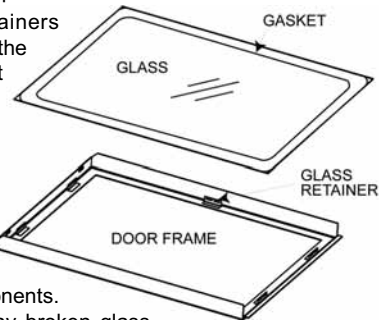
## GLASS/DOOR REPLACEMENT

The glass door is secured at the top front edge of the fireplace. Pull the latch forward then lift hook out from slot in the door. Tilt door forward then lift out from retainer along the bottom edge of the fireplace.

1. Place the door frame face down careful not to scratch the paint.

2. Center the gasketed glass inside the door frame with the thick side of the gasket facing up.

3. Bend the glass retainers located along the edge of the door frame over the gasket holding the glass in place. Careful not to break the glass.



**FIGURE 48**

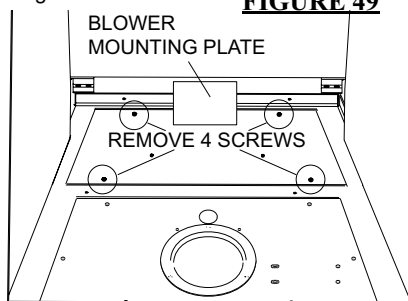
**NOTE:** Care must be taken when removing and disposing of any broken glass or damaged components. Be sure to vacuum up any broken glass from inside the fireplace before operation.

## BLOWER REPLACEMENT

Your *Park Avenue* comes equipped with a heat circulating blower. The blower is pre-wired and is controlled by the remote control supplied with the unit.

**Drywall dust will penetrate into the blower bearings, causing irreparable damage. Care must be taken to prevent drywall dust from coming into contact with the blower or its compartment. Any damage resulting from this condition is not covered by the warranty policy.**

1. Turn off the power to the fireplace.
2. Turn off the gas valve.

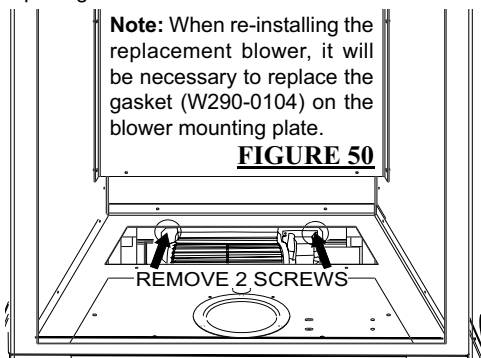


3. Remove the glass door, logs, rear log supports, brick panels, air deflector, burner assy, panel support, panel support bracket.

4. The blower mounting plate can now be removed. Remove the four screws that secure the plate to the firebox base.

5. The blower is secured to the firebox. Disconnect the wire connectors before attempting to remove the blower from the firebox.

6. Remove the two screws securing the blower and lift through blower access opening.



## BURNER AND VALVE REPLACEMENT

### 1a. Rectangular Front Removal

Pull on the top of the optional front away from the fireplace until the male portion of the latch disengages. Tilt forward slightly and lift from the 2 shoulder screws near the bottom.

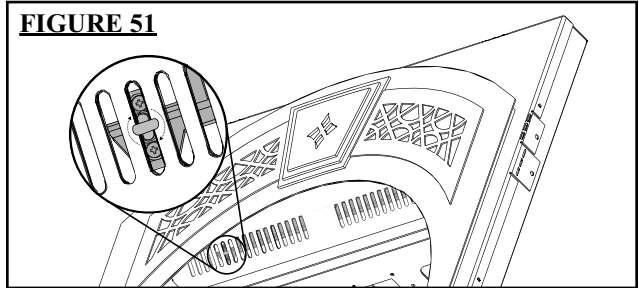
### 1b. Heritage and Wrought Iron Front Removal

Turn the head of each turn button from a horizontal position to vertical. Allow the front to tilt forward slightly and lift from the 2 shoulder screws near the bottom front. **Note: Fronts are heavy so when the second turn button is turned the front will want to fall forward.** See Figure 51.

### 2. Control Panel Removal

Tilt control panel away from the door and lift from slots. See Figure 53.

**FIGURE 51**



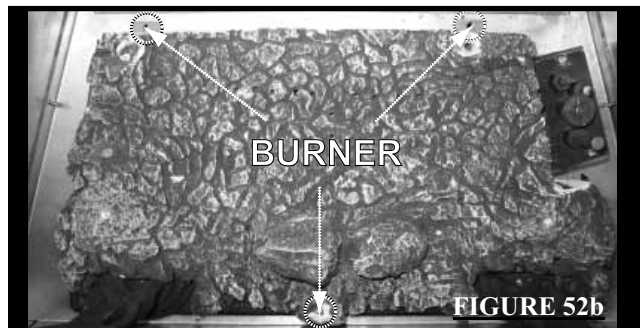
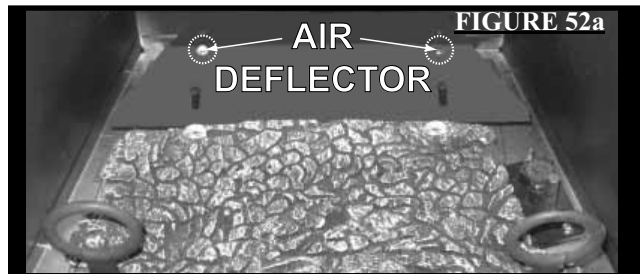
3. Turn Power and Gas off to the unit.

4. Door Removal.

See door removal section.

5. Burner Removal

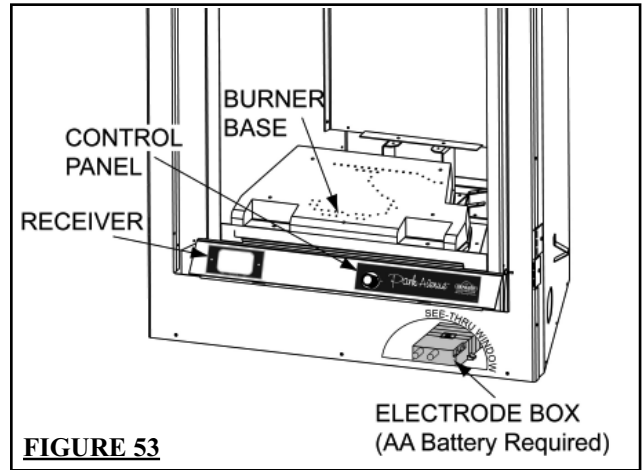
Start by removing the logs being careful since the logs may still be warm. Remove the 2 screws holding the air deflector (Figure 52a) then remove the 3 screws holding the burner (Figure 52b). Lift burner from firebox.



6. Remove the 5 screws securing the burner base. Once the gas has been disconnected, the valve train assembly will lift out. Service components as required.

## SPARK MODULE BATTERY REPLACEMENT

1. Remove optional front. (Instructions on Pg. 19)
2. Tilt the control panel forward and remove allowing access to the electrode box which is screwed to the base of the firebox. (Fig. 53)
3. Pull back on the battery compartment door latch and remove.
4. Replace battery.
5. Reinstall battery compartment and control doors.

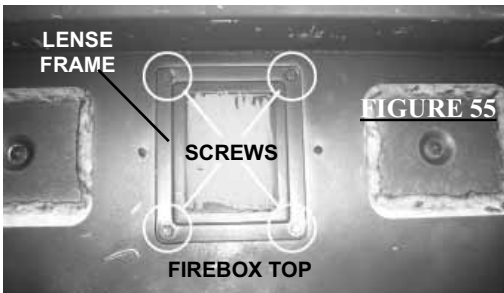


## NIGHT LIGHT™ REPLACEMENT

Your *Park Avenue* comes equipped with our "Night Light™". The light has been pre-wired and is controlled from the remote control. If in the event the lamp or lens needs to be replaced, follow the instructions below.

Unplug the wire harness / transformer from the FCM (Fan Control Module) inside the fireplace.

**FIGURE 54**

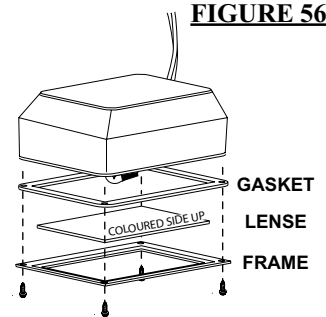


Remove the four screws that secure the lens frame.

This frame retains the glass lens. The lamp can now be accessed.

**Note: Do not handle the lamp (bulb) with bare fingers, protect with a clean dry cloth.** The lamp will pull straight out of the socket. Replace with Wolf Steel parts only, as lamp and lens are special "high temperature" products.

When re-installing, ensure integrity of gasket seal.



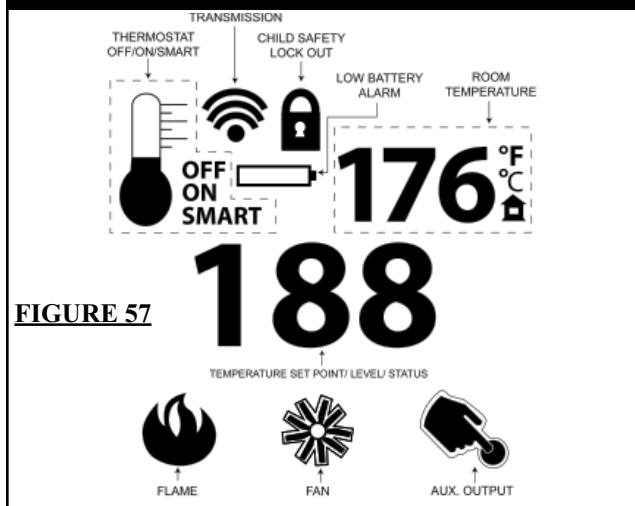
**THE FIREBOX MUST BE SEALED.**

Over tightening the screws could break the lens.

"Light Leakage" from the upper area may be observed. The holes in the lamp housing are necessary for ventilation and must not be covered.

## OPERATION

### GENERAL TRANSMITTER LAYOUT



### FIREPLACE OPERATION

1. Install 4 AA batteries into the receiver battery bay as indicated on the battery cover (+/-).
2. Place the 3 position slider switch in the "Remote" position.
3. Using the end of a paper clip, or other similar object, insert the end of the paper clip into the hole marked "PRG" on the receiver front cover. The receiver will "beep" three (3) times to indicate that it is ready to synchronize with the transmitter.
4. Install the 3 AAA batteries in the transmitter as indicated in the battery bay, located on the base of the transmitter. With the batteries already installed in the transmitter, push the "ON" button. The receiver will "beep" four times to indicate the transmitter's command is accepted and set to the particular code of that transmitter. The system is now initialized.

## HAND HELD REMOTE OPERATIONS

1. Press the ON/OFF key on the transmitter, it controls all functions of the remote. The transmitter display will show all active icons on the screen. At the same time the receiver turns on the main burner and a single “beep” from the receiver will confirm reception of the command.
2. Press the ON/OFF key on the transmitter. The transmitter LCD display will only show the room temperature and icon. At the same time the receiver will turn the burner off and the appliance burner turns off. A single “beep” from the receiver confirms reception of the command.

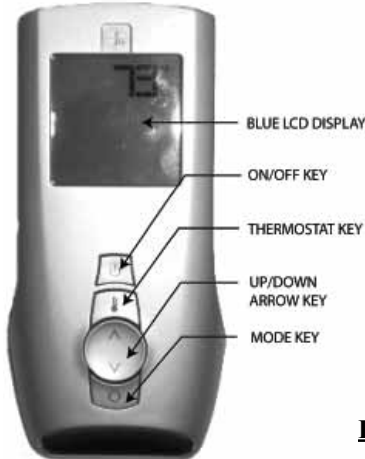


FIGURE 58

## TEMPERATURE DISPLAY

1. With the system in the “OFF” position, press the Thermostat Key and the Mode Key at the same time to change the temperature from Fahrenheit to Celsius.
  2. Check the LCD screen on the Transmitter to verify that a C or F is visible to the right of the Room Temperature display.
- With the thermostat in the off mode, the flame height may be chosen and the main burner left on, regardless of the room temperature. To turn off the flame, either turn off the on/off key or reduce flame height to the off position.

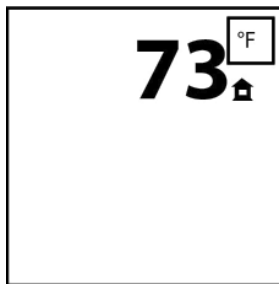


FIGURE 59

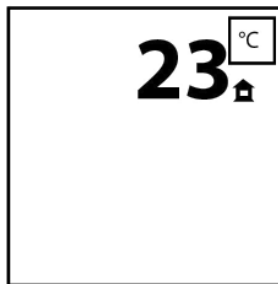


FIGURE 60

## ROOM THERMOSTAT

The remote control can operate as a room thermostat. The thermostat can be set to a desired temperature to control the comfort level in the room.

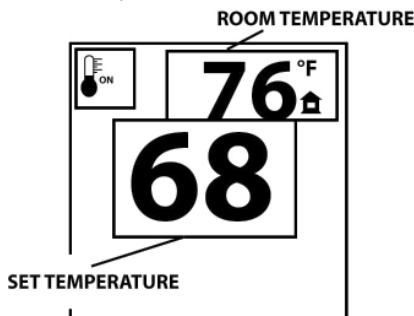


FIGURE 61

1. Press the Thermostat Key. The LCD display on the Transmitter will show that the room is “ON” and the set temperature is now displayed.
2. To adjust the set temperature, press the Up/Down Arrow Keys until the desired set temperature is displayed on the LCD screen of the Transmitter.

## SMART THERMOSTAT

The Smart Thermostat function adjusts the flame height according to the difference between the set temperature and the actual room temperatures. As the room temperature gets closer to the set point the Smart Function will automatically adjust the flame down.



FIGURE 62

1. Press the thermostat key until the word “SMART” appears to the right of the temperature bulb graphic.
2. To adjust the set temperature, press the Up/Down arrow keys until the desired set temperature is displayed on the LCD screen at the Transmitter.

## FLAME HEIGHT

The remote control has six (6) flame levels. With the system on and the flame level at the maximum, press the Down Arrow Key once and it will reduce the flame height by one step until the flame is turned off.

The Up Arrow Key will increase the flame height each time it is pressed. If the Up Arrow Key is pressed while the system is on but the flame is off, the flame will come on the high position. A single “beep” will confirm reception of the command.



FIGURE 63

Flame OFF

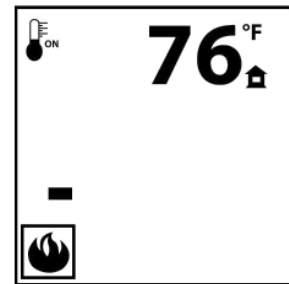


FIGURE 64

Flame at level 1

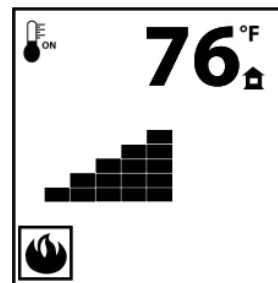


FIGURE 65

Flame at level five

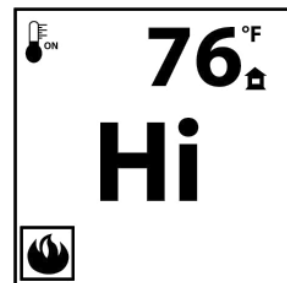


FIGURE 66

Flame at “HI” level six

### FAN SPEED

If the appliance is equipped with a hot air circulating fan, the speed of the fan can be controlled by the remote system. The fan speed can be adjusted through six (6) speeds.

1. Use the Mode key to guide you to the fan control icon.
2. Use the Up/Down Arrow keys to turn ON/OFF or adjust the fan speed.

A single “beep” will confirm reception of the command.



**FIGURE 67**  
Blower off

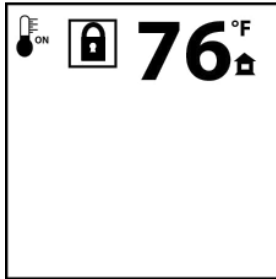


**FIGURE 68**  
Blower “HI” level six

### CHILD PROOF FUNCTION

This function will lock the keys to avoid unsupervised operation.

1. Press the MODE and UP keys at the same time.
2. To de-activate this function, press the MODE and UP keys at the same time.



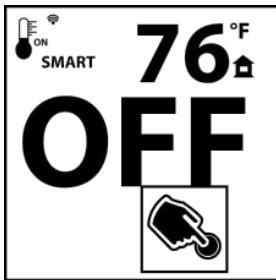
**FIGURE 69**

### REMOTE AUXILIARY OUTLET

The auxiliary function controls the Night Light™.

1. Use the Mode Key to guide you to the AUX icon.
2. Pressing the Up Arrow Key will activate the light.
3. Pressing the Down Arrow Key will turn the light off.

A single “beep” will confirm the reception of the command.



**FIGURE 70**



**FIGURE 71**

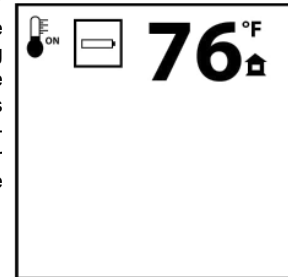
### LOW BATTERY / MANUAL BYPASS

The life span of the remote batteries depends on various factors: quality of the batteries, the number of ignitions, the number of changes to the room thermostat set point, etc.

When the transmitter batteries are low, a Battery Icon will appear on the LCD display before all battery power is lost. When the batteries are replaced this icon will disappear.

When the receiver batteries are low, no “beep” will be emitted from the receiver when it receives an ON/OFF command. This is an alert for the receiver that there’s low battery. When the batteries are replaced the “beep” will be emitted from the receiver when the ON/OFF Key is pressed.

If the batteries of the receiver or transmitter are low, the appliance can be turned on manually by sliding the three position slider switch on the receiver to the “ON” position. This will bypass the remote control feature and the appliance main burner will come on if the gas valve is in the “ON” position.



**FIGURE 72**

To restore button function temporarily, press the Up and Down buttons in the following sequence:

**up-down-down-up-down**

If no button is pressed within 2 minutes, the transmitter will return to the Child-Proof mode.

### IN THE EVENT OF A POWER FAILURE

Refer to remote operation.

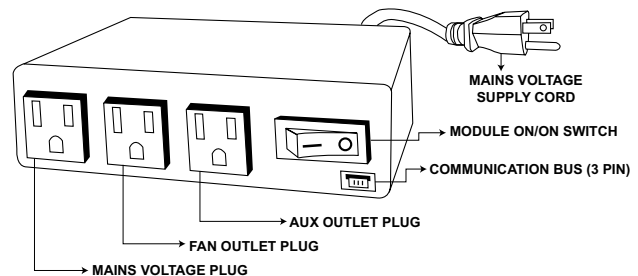
*The receiver will emit a “beep” sound to confirm programming has been successful once power is restored.*

### FAN CONTROL MODULE

Fan Control Module (FCM) offers the added ability to control the fan speed through six (6) speeds, a remotely actuated 120V AUX outlet and a constantly powered 120V outlet. The FCM provides DC power to the receiver allowing the batteries to be used only when line power is interrupted or lost.

**Note:** Control module ON/OFF switch should always be in the “ON” position. If for any reason the module is turned OFF the components plugged into the module won’t have power.

**FIGURE 73**





## OPERATING INSTRUCTIONS

When lit for the first time, the fireplace will emit a slight odor for a few hours. This is a normal temporary condition caused by the curing of paints and lubricants used in the manufacturing process and will not occur again. Simply open a window to sufficiently ventilate the room.

After extended periods of non-operation such as following a vacation

or a warm weather season, the fireplace may emit a slight odor for a few hours. This is caused by dust particles in the heat exchanger burning off. Open a window to sufficiently ventilate the room.

**Purge all gas lines with the glass door of the fireplace open. Assure that a continuous gas flow is at the burner before closing the door.**

### FOR YOUR SAFETY READ BEFORE LIGHTING:

- This fireplace is equipped with a pilot which must be lit by hand while following these instructions exactly.
- Before operating smell all around the fireplace area for gas and next to the floor because some gas is heavier than air and will settle on the floor.
- Use only your hand to turn the gas control knob / manual shut-off knob. Never use tools. If the knob will not turn by hand, do not try to repair it. Call a qualified service technician. Force or attempted repair may result in a fire or explosion.
- Do not use this fireplace if any part has been under water. Immediately call a qualified service technician to inspect the fireplace and replace any part of the control system and any gas control which has been under water.

### WHAT TO DO IF YOU SMELL GAS

- Do not touch any electric switch.
- Do not use any phone in your building.
- If you cannot reach your gas supplier, call the fire department.
- Turn off all gas to the fireplace.
- Do not try to light any appliance.
- Immediately call your gas supplier from a neighbor's phone. Follow the gas supplier's instructions.

**FIGURE 74**






### LIGHTING INSTRUCTIONS

**Warning:** if you do not follow these instructions exactly, a fire or explosion may result causing property damage, personal injury or loss of life. Initial lighting of the pilot and main burners must be done with the glass door off.

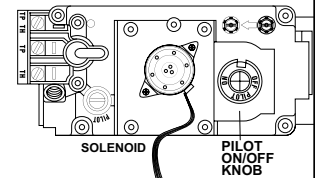
Do not connect valve or wall switch to electricity. See installation instructions.

When lighting and re-lighting, the gas knob cannot be turned from pilot to off unless the knob is depressed slightly.



- STOP!** Read the safety information on the operating label.
- Turn off all electric power to the fireplace.
- Turn the gas knob clockwise  to off.
- Wait 5 minutes to clear out any gas. If you smell gas, including near the floor, **STOP!** Follow "B" on the operating label. If you don't smell gas, go to the next step.
- If the fireplace is equipped with a flame adjustment valve, turn clockwise to off.
- Find pilot located in front of the back log on the right side.

- Turn gas knob counter-clockwise  to pilot.
- This unit is equipped with an auto-spark. Depress and hold gas knob. Keep knob fully depressed for one minute, then release. If pilot does not continue to burn repeat steps 3 through 7.
- With pilot lit, turn gas knob counter-clockwise  to on.
- If equipped with flame adjustment valve, push and turn knob to high.
- If equipped with remote on-off switch, main burner may not come on when you turn the valve to on or high. Remote switch must be in the on position to ignite burner.
- Turn on all electric power to the fireplace.

**FIGURE 75**



### TO TURN OFF GAS

- Turn off all electric power to the fireplace if service is to be performed.
- For a complete shut-down procedure: push in gas control knob slightly and turn  clockwise to off. Do not force.
- For a temporary shut-down procedure: set thermostat to lowest setting or remote switch to off. Press and turn the gas knob clockwise  to pilot.

# ADJUSTMENTS

## PILOT BURNER ADJUSTMENT

Adjust the pilot screw to provide properly sized flame. Turn in a clockwise direction to reduce the gas flow.

### Check Pressure Readings: (Fig. 76)

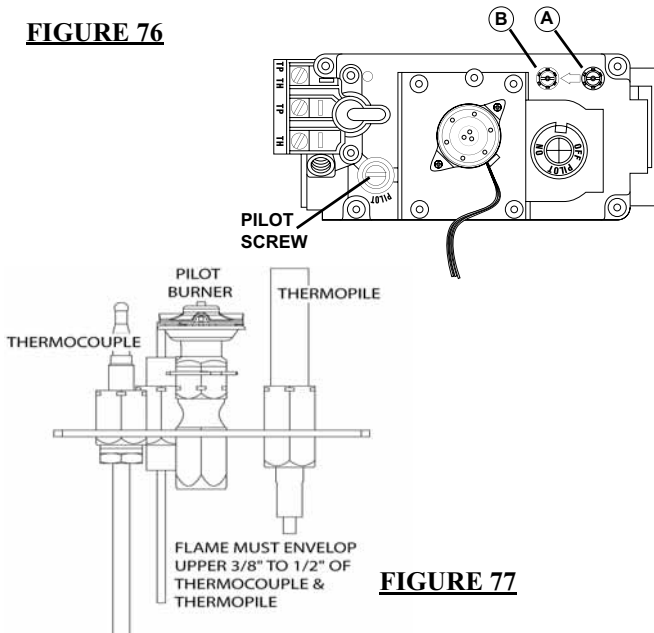
Inlet pressure can be checked by turning screw (A) counter-clockwise 2 or 3 turns and then placing pressure gauge tubing over the test point. Gauge should read 7" (minimum 4.5") water column for natural gas or 13" (11" minimum) water column for propane. Check that main burner is operating on "HI".

Outlet pressure can be checked the same as above using screw (B). Gauge should read 3.5" water column for natural gas or 10" water column for propane. Check that main burner is operating on "HI".

**AFTER TAKING PRESSURE READINGS, BE SURE TO TURN SCREWS CLOCKWISE FIRMLY TO RESEAL. DO NOT OVERTORQUE.**

Leak test with a soap and water solution.

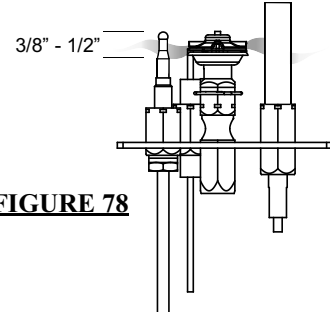
**FIGURE 76**



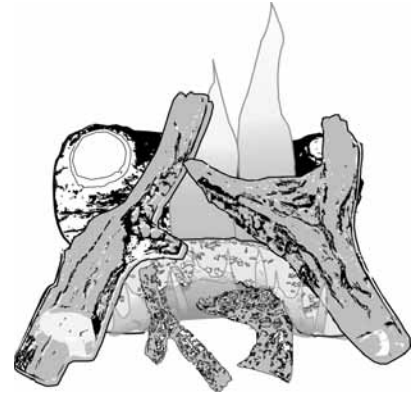
**FIGURE 77**

## FLAME CHARACTERISTICS

It is important to periodically perform a visual check of the pilot and burner flames. Compare them to the illustration below.



**FIGURE 78**



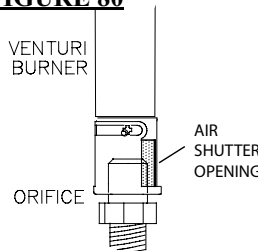
**FIGURE 79**

## VENTURI ADJUSTMENT

Closing the air shutter will cause a more yellow flame, but can lead to carboning. Opening the air shutter will cause a more blue flame, but can cause flame lifting from the burner ports. The flame may not appear yellow immediately; allow 15 to 30 minutes for the final flame color to be established.

| AIR SHUTTER OPENINGS |       |
|----------------------|-------|
| LP                   | 1/2"  |
| NG                   | 1/16" |

**FIGURE 80**



## MAINTENANCE

### TURN OFF THE GAS AND ELECTRICAL POWER BEFORE SERVICING THE FIREPLACE.

**CAUTION:** Label all wires prior to disconnection when servicing controls. Wiring errors can cause improper and dangerous operation. Verify proper operation after servicing. This fireplace and its venting system should be inspected before use and at least annually by a qualified service person. The fireplace area must be kept clear and free of combustible materials, gasoline or other flammable vapors and liquids. The flow of combustion and ventilation air must not be obstructed.

1. In order to properly clean the burner and pilot assembly, remove the log and burner to expose both assemblies.
2. Keep the control compartment, log, burner, air shutter opening and the area surrounding the logs clean by vacuuming or brushing, at least once a year.

3. Check to see that all burner ports are burning. Clean out any of the ports which may not be burning or are not burning properly.
4. Check to see that the pilot flame is large enough to engulf the thermocouple and thermopile and reaches toward the burner with the third jet.
5. Replace the cleaned log and burner.
6. Check to see that the main burner ignites completely on all openings when the gas knob for the burner is turned on. A 5 to 10 second total light-up period is satisfactory. If ignition takes longer, consult your Napoleon® dealer / distributor.
7. Check that the gasketing on the sides, top and bottom of the door is not broken or missing. Replace if necessary.
8. If for any reason the vent air intake system is disassembled, reinstall and re-seal per the instructions provided for the initial installation.

# REPLACEMENTS

Contact your dealer for questions concerning prices and availability of replacement parts. Normally all parts can be ordered through your Napoleon® dealer or distributor.

When ordering replacement parts always give the following information:

1. MODEL & SERIAL NUMBER OF FIREPLACE
2. INSTALLATION DATE OF FIREPLACE
3. PART NUMBER
4. DESCRIPTION OF PART
5. FINISH

FOR WARRANTY REPLACEMENT PARTS, A PHOTOCOPY OF THE ORIGINAL INVOICE WILL BE REQUIRED TO HONOUR THE CLAIM.

\* IDENTIFIES ITEMS WHICH ARE NOT ILLUSTRATED. FOR FURTHER INFORMATION, CONTACT YOUR NAPOLEON® DEALER.

## REPLACEMENT PARTS

| #   | PART NO.   | DESCRIPTION                    |
|-----|------------|--------------------------------|
| 1   | W135-0267  | #1 - REAR LOG                  |
| 2   | W135-0268  | #2 - MIDDLE LOG                |
| 3   | W135-0269  | #3 - RIGHT LOG                 |
| 4   | W135-0270  | #4 - LEFT LOG                  |
| 5   | W135-0273  | #5 - LEFT STICK                |
| 6   | W135-0274  | #6 - RIGHT STICK               |
| 7   | GL-654     | LOG SET ASSEMBLY               |
| 8*  | W390-0002  | DOOR LATCH (EA)                |
| 9   | W725-0047  | NATURAL GAS VALVE - MODULATING |
| 9   | W725-0048  | PROPANE GAS VALVE - MODULATING |
| 10  | W455-0017  | NATURAL GAS ORIFICE #42        |
| 10  | W455-0003  | PROPANE GAS ORIFICE #54        |
| 11  | W680-0005  | THERMOCOUPLE **                |
| 12  | W240-0005  | ELECTRODE c/w LEAD             |
| 13  | W680-0004  | THERMOPILE                     |
| 14  | W010- 1194 | NATURAL GAS PILOT ASSEMBLY     |
| 14  | W010- 1201 | PROPANE GAS PILOT ASSEMBLY     |
| 15  | W455-0070  | NG PILOT INJECTOR              |
| 15  | W455-0068  | LP PILOT INJECTOR              |
| 16* | W385-0245  | NAPOLEON® LOGO                 |
| 17* | W562-0008  | DOOR GASKET (100 INCHES)       |
| 18  | W100-0087  | BURNER                         |
| 19  | GD 552     | BLOWER                         |
| 20  | W660-0041  | SPARK SWITCH                   |
| 21  | W660-0071  | REMOTE TRANSMITTER             |
| 22  | W660-0070  | REMOTE RECEIVER                |
| 23  | W190-0017  | DC SPARK UNIT CONTROL          |
| 24  | W300-0067  | ACCENT LIGHT GLASS             |
| 25  | W387-0006  | ACCENT LAMP                    |
| 26  | W750-0107  | ACCENT LIGHT WIRE              |
| 27  | W290-0080  | ACCENT LENSE GASKET            |
| 28* | W361-0027  | INSULATION SLEEVE              |
| 29* | W475-0401  | PANEL, REAR FIBRE              |
| 30* | W475-0402  | PANEL, RIGHT FIBRE             |
| 31* | W475-0403  | PANEL, LEFT FIBRE              |
| 32  | W225-0171  | DOOR                           |
| 33* | W300-0082  | GLASS                          |
| 34* | W500-0205  | RESTRICTOR                     |
| 35  | W010-1799  | FIRESTOP SPACER                |
| 36  | W660-0069  | FAN CONTROL MODULE             |

## ! WARNING

\*\* **WARNING:** This is a fast acting thermocouple. It is an integral safety component. Replace only with a fast acting thermocouple supplied by Wolf Steel Ltd.

## ! WARNING

Failure to position the parts in accordance with these diagrams or failure to use only parts specifically approved with this appliance may result in property damage or personal injury.

## FLEXIBLE VENT KITS

### GD220 (5 FT)

|     |           |   |
|-----|-----------|---|
| 37* | W010-0397 | 4" FLEXIBLE VENT PIPE<br>- (5 FT) c/w SPACERS |
| 37* | W410-0017 | 7" FLEXIBLE VENT PIPE - (5 FT)                |

### GD330 (10 FT)

|     |           |  |
|-----|-----------|--|
| 38* | W010-0300 | 4" FLEXIBLE VENT PIPE<br>- (10 FT) c/w SPACERS |
| 38* | W410-0018 | 7" FLEXIBLE VENT PIPE - (10 FT)                |
| 39* | W010-0370 | WALL SUPPORT ASSEMBLY                          |

## TERMINAL KITS

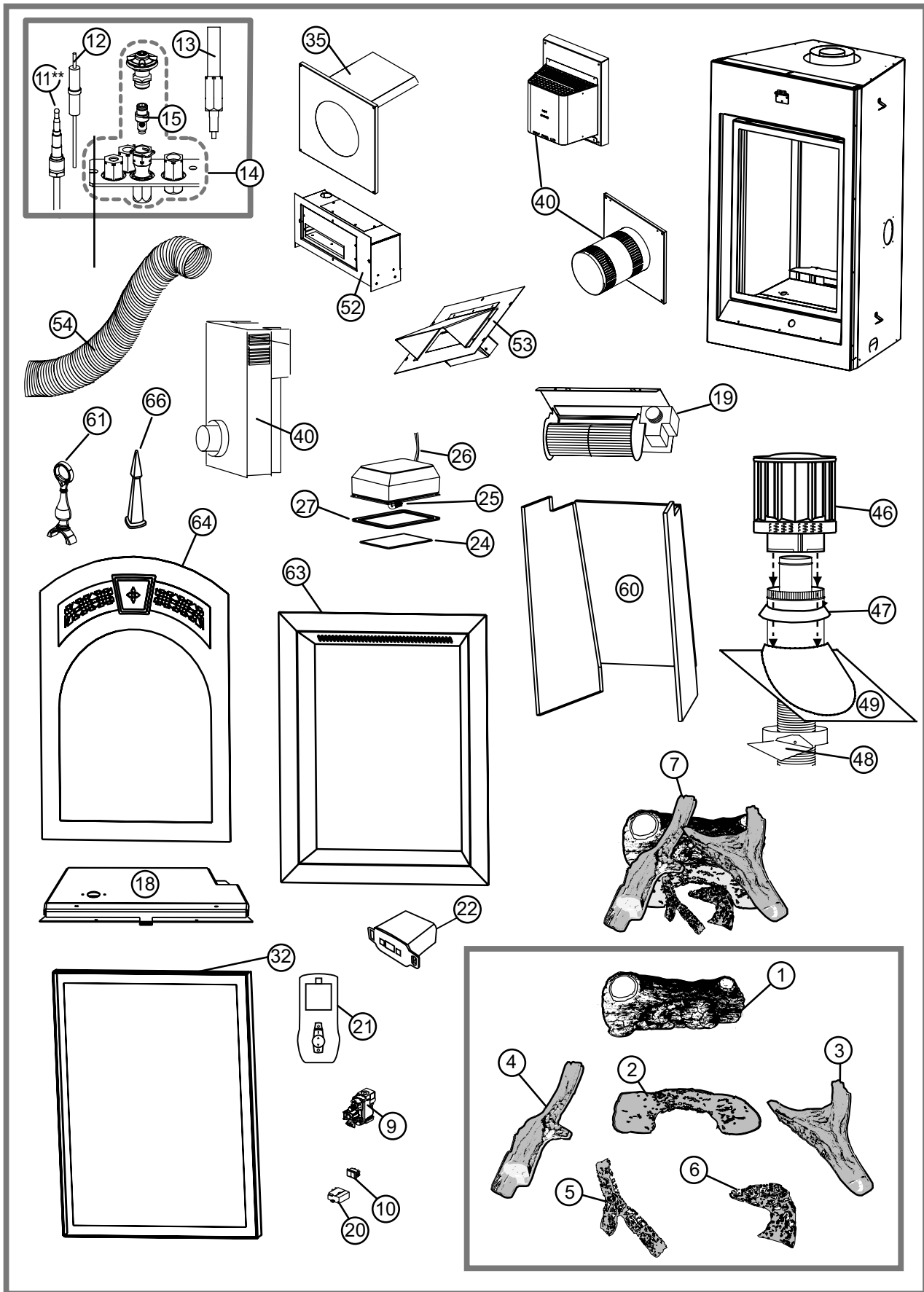
|    |                           |          |
|----|---------------------------|----------|
| 40 | PERISCOPE                 | - GD201  |
| 41 | WALL TERMINAL KIT (ROUND) | - GD222R |
| 41 | WALL TERMINAL KIT         | -GD222   |

## ROOF TERMINAL KITS

|     |                     |                        |
|-----|---------------------|------------------------|
| 42* | 1/12 TO 7/12 PITCH  | - GD110                |
| 43* | 8/12 TO 12/12 PITCH | - GD111                |
| 44* | FLAT ROOF           | - GD112                |
| 45* | W490-0073           | 4/7 INNER/OUTER SLEEVE |
| 46  | W670-0006           | 4/7 TERMINAL           |
| 47  | W170-0086           | STORM COLLAR           |
| 48  | W010-0453           | ROOF SUPPORT           |
| 49  | W263-0065 /         | ROOF FLASHING FLAT     |
|     | W263-0066 /         | 1/12 TO 7/12 FLASHING  |
|     | W263-0067           | 8/12 TO 12/12 FLASHING |

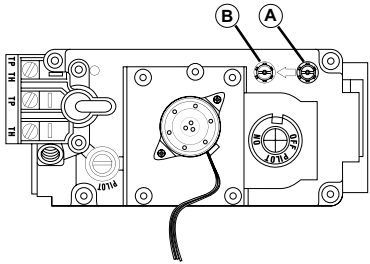
## ACCESSORIES

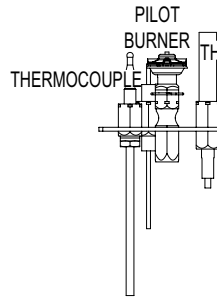
|     |           |                                 |
|-----|-----------|---------------------------------|
| 50* | W573-0007 | HI-TEMP SEALANT                 |
| 51* | GD501     | HEAT GUARD                      |
| 52  | GA-566    | HOT AIR DISTRIBUTION KIT        |
| 53  | GA-72     | HOT AIR EXHAUST KIT             |
| 54  | GA-70     | EXTENSION KIT, 5FT FLEX VENT    |
| 55* | W010-0370 | WALL SUPPORT ASSEMBLY           |
| 56* | W175-0001 | 4" COUPLER                      |
| 57* | W175-0013 | 7" COUPLER                      |
| 58* | W175-0239 | CONVERSION KIT - NG TO LP       |
| 59* | W175-0240 | CONVERSION KIT - LP TO NG       |
| 60  | GD811-KT  | HERRINGBONE/SANDSTONE BRICK KIT |
| 61  | W135-0148 | ANDIRON                         |
| 62* | GD812-KT  | REFRACTORY PANEL KIT            |
| 63  | RFK82     | RECTANGLE FACING KIT            |
| 64  | AFK82     | ARCHED FACING KIT               |
| 65* | RFK82WI   | WROUGHT IRON FACING KIT         |
| 66  | W135-0271 | ANDIRON (OBELISK)               |



# TROUBLE SHOOTING GUIDE

BEFORE ATTEMPTING TO TROUBLESHOOT, PURGE YOUR UNIT AND INITIALLY LIGHT THE PILOT AND THE MAIN BURNER WITH THE GLASS DOOR OPEN.

| SYMPTOM   | PROBLEM   | TEST SOLUTION  |
|---|---|--|
| Main burner flame is a blue, lazy, transparent flame.   | Blockage in vent.   | - remove blockage. In really cold conditions, ice buildup may occur on the terminal and should be removed as required.   |
|   | Incorrect installation.   | - refer to Figure 13 to ensure correct location of storm collars.  |
| Flames are consistently too large or too small. Carboning occurs.   | Unit is over-fired or under-fired.  | - check pressure readings:<br>Inlet pressure can be checked by turning screw (A) counter-clockwise 2 or 3 turns and then placing pressure gauge tubing over the test point. Gauge should read 7" (minimum 4.5") water column for natural gas or 13" (11" minimum) water column for propane. Check that main burner is operating on "HI".<br>Outlet pressure can be checked the same as above using screw (B). Gauge should read 3.5" water column for natural gas or 10" water column for propane. Check that main burner is operating on "HI".<br><b>AFTER TAKING PRESSURE READINGS, BE SURE TO TURN SCREWS CLOCKWISE FIRMLY TO RESEAL. DO NOT OVERTORQUE.</b><br>Leak test with a soap and water solution. |
|   |   |   |
| Carbon is being deposited on glass, logs or combustion chamber surfaces.  | Air shutter has become blocked  | - ensure air shutter opening is free of lint or other obstructions.  |
|   | Flame is impinging on the logs or combustion chamber.                               | - check that the logs are correctly positioned.<br>- open air shutter to increase the primary air.<br>- check the input rate: check the manifold pressure and orifice size as specified by the rating plate values.<br>- check that the door gasketing is not broken or missing and that the seal is tight.<br>- check that both 4" and 7" vent liners are free of holes and well sealed at all joints.<br>- check that minimum rise per foot has been adhered to for any horizontal venting.  |
| White / grey film forms.  | Sulphur from fuel is being deposited on glass, logs or combustion chamber surfaces. | - clean the glass with a gas fireplace glass cleaner. <b>DO NOT CLEAN GLASS WHEN HOT.</b><br>If deposits are not cleaned off regularly, the glass may become permanently marked.   |
| Exhaust fumes smelled in room, headaches.   | Fireplace is spilling.  | - check door seal and relief flap seal.<br>- check for chimney blockage<br>- check that the paint curing process is complete   |
| Pilot goes out when the gas knob is released.<br><b>The gas valve has an interlock device which will not allow the pilot burner to be lit until the thermocouple has cooled. Allow approximately 60 seconds for the thermocouple to cool.</b> | System is not correctly purged.   | - purge the gas line with the glass door open.   |
|   | Out of propane gas.   | - fill the tank.   |
|   | Pilot flame is not large  | - turn up the pilot flame.   |
|   | Pilot flame is not engulfing the thermocouple.                                      | - gently twist the pilot head to improve the flame pattern around the thermocouple.  |
|   | Thermocouple shorting / faulty.   | - loosen and tighten thermocouple.<br>- clean thermocouple and valve connection.<br>- replace thermocouple.<br>- replace valve.  |
|   | Faulty valve.   | - replace.   |

| SYMPTOM  | PROBLEM   | TEST SOLUTION  |
|--|---|--|
| Pilot burning; no gas to main burner; gas knob is on 'HI'; wall switch / thermostat is on.                     | Thermostat or switch is defective.                                      | - connect a jumper wire across the wall switch terminals; if main burner lights, replace switch / thermostat.  |
|  | Wall switch wiring is defective.  | - disconnect switch wires & connect a jumper wire across terminals 1 & 3; if the main burner lights, check the wires for defects and / or replace wires.   |
|  | Main burner orifice is plugged.   | - remove stoppage in orifice.  |
|  | Faulty valve.   | - replace.   |
| Pilot goes out while standing; Main burner is in 'OFF' position.   | Gas piping is undersized.   | <ul style="list-style-type: none"> <li>- turn on all gas appliances and see if pilot flame flutters, diminishes or extinguishes, especially when main burner ignites. Monitor appliance supply working pressure.</li> <li>- check if supply piping size is to code. Correct all undersized piping.</li> </ul>  |
|  <p>Pilot will not light.</p> | No spark at pilot burner  | <ul style="list-style-type: none"> <li>- check if pilot can be lit by a match</li> <li>- check that the wire is connected to the push button ignitor.</li> <li>- check if the push button ignitor needs tightening.</li> <li>- replace the wire if the wire insulation is broken or frayed.</li> <li>- replace the electrode if the ceramic insulator is cracked or broken.</li> <li>- replace the push button ignitor.</li> </ul> |
|  | Out of propane gas  | - fill the tank.   |
|  | Spark gap is incorrect  | - spark gap should be 0.150" to 0.175" (5/32" to 11/64" approx.) from the electrode tip and the pilot burner. To ensure proper electrode location, tighten securing nut (finger tight plus 1/4 turn).  |
|  | No gas at the pilot burner  | <ul style="list-style-type: none"> <li>- check that the manual valve is turned on.</li> <li>- check the pilot orifice for blockage.</li> <li>- replace the valve.</li> <li>- call the gas distributor.</li> </ul>  |
| Main burner goes out; pilot stays on.  | Pilot flame is not large enough or not engulfing the thermopile         | <ul style="list-style-type: none"> <li>- turn up pilot flame.</li> <li>- replace pilot assembly.</li> </ul>  |
|  | Thermopile shorting   | <ul style="list-style-type: none"> <li>- clean thermopile connection to the valve. Reconnect.</li> <li>- replace thermopile / valve.</li> </ul>  |
|  | Remote wall switch wire is too long; too much resistance in the system. | - shorten wire to correct length or wire gauge.  |
|  | Faulty thermostat or switch.  | - replace.   |
| Main burner goes out; pilot goes out.  | Refer to "MAIN BURNER GOES OUT; PILOT STAYS ON"                         |  |
|  | Vent is blocked   | - check for vent blockage.   |
|  | Vent is re-circulating  | - check joint seals and installation.  |
| 4" flexible vent has become disconnected from fireplace.   | - re-attach to fireplace.   |  |
| Remote wall switch is in "OFF" position; main burner comes on when gas knob is turned to "ON" position.        | Wall switch is mounted upside down                                      | - reverse.   |
|  | Remote wall switch is grounding.  | - replace.   |
|  | Remote wall switch wire is grounding.                                   | - check for ground (short); repair ground or replace wire.   |
|  | Faulty valve.   | - replace.   |

# **WOLF STEEL** Fireplace Service History

This fireplace must be serviced annually depending on usage

| DATE | DEALER NAME | SERVICE TECHNICIAN NAME | SERVICE PERFORMANCE | SPECIAL CONCERNS |
|------|-------------|-------------------------|---------------------|------------------|
|      |             |                         |                     |                  |
|      |             |                         |                     |                  |
|      |             |                         |                     |                  |
|      |             |                         |                     |                  |
|      |             |                         |                     |                  |
|      |             |                         |                     |                  |
|      |             |                         |                     |                  |
|      |             |                         |                     |                  |
|      |             |                         |                     |                  |
|      |             |                         |                     |                  |
|      |             |                         |                     |                  |
|      |             |                         |                     |                  |
|      |             |                         |                     |                  |
|      |             |                         |                     |                  |
|      |             |                         |                     |                  |
|      |             |                         |                     |                  |
|      |             |                         |                     |                  |
|      |             |                         |                     |                  |
|      |             |                         |                     |                  |

**NOTES**

---

---

---

---

---

---

---

---

---

---

---

---

---

---

---

---

---

---

---

---

---

---

---

---

---

---

---

---

---

---