

Print Vendor Instructions

How to use this file Operator's Manuals

- Paper Size:**
- 11x17
 - Body - 50 lbs brilliant white offset or equivalent
 - Cover - on pre-printed two tone "Swash" stock.
- Press:**
- Body - 1 color, 2-sided
 - Cover - 1 color, 1 sided
- Bindery:**
- Saddle stitch, face trim *if too thick for saddle stitch, tape bind
- Covers:**
- FRONT COVER is present at the beginning of the file.
 - BACK COVER is the page immediately after the front cover.
 - The part number for this manual (typically a 172_____ number) is located on the front cover.
 - This file may contain several manual which differ only by their covers. See the part number at the bottom of the cover page. .
- Body:**
- The body for all manuals is identical regardless of the cover.
 - Odd number pages are always right hand pages, even number pages are always left hand pages.
- General:**
- This instruction sheet is NOT part of the manual and must not be printed.
 - Pages labeled "THIS PAGE INTENSIONALLY BLANK" are placement pages and should NOT be printed.

**THIS PAGE INTENTIONALLY BLANK
(FOR PLACEMENT ONLY - DO NOT PRINT)**



OPERATOR'S MANUAL



Large Frame Snowthrowers

860 DLX Models

Mfg. No.	Description
1693652	860 DLX, 8HP Snowthrower
1693653	860 DLX, 8HP Snowthrower (CE)
1694241	860 DLXE, 8 HP Snowthrower

1180 Models

Mfg. No.	Description
1693656	1180M, 11HP Snowthrower
1693657	1180M, 11HP Snowthrower (CE)
1694244	1180E, 11HP Snowthrower

970 Models

Mfg. No.	Description
1693654	970M, 9HP Snowthrower
1693655	970M, 9HP Snowthrower (CE)
1694243	970E, 9HP Snowthrower

1280 Models

Mfg. No.	Description
1694438	1280M, 12HP Snowthrower (CE)
1694442	1280E, 12HP Snowthrower

1060 Models

Mfg. No.	Description
1694436	1060M, 10HP Snowthrower (CE)
1694440	1060E, 10HP Snowthrower

1390 Models

Mfg. No.	Description
1694237	1390E, 13HP Snowthrower
1694266	1390M, 13HP Snowthrower (CE)
1694443	1390M, 13HP Snowthrower (CE)
1694444	1390E, 13HP Snowthrower

1170 Models

Mfg. No.	Description
1694437	1170M, 11HP Snowthrower (CE)
1694441	1170E, 11HP Snowthrower

1720534-07

Rev 4/2003
TP 100-2289-07-LW-S



Simplicity

MANUFACTURING, INC.
500 N Spring Street / PO Box 997
Port Washington, WI 53074-0997

www.simplicitymfg.com

© Copyright 2003, Simplicity Manufacturing, Inc.
All Rights Reserved. Printed in USA.



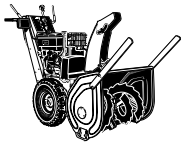

Table of Contents

CONTENTS:

Safety Rules & Information

General Operation	2
Slope Operation.....	2
Children	3
Emissions	3
Service & Maintenance	3
ANSI B71.3-1995 Warnings	4
Decals.....	5
Safety Icons.....	6

Identification Numbers.....7

Features, Controls, & Operation

Control Locations.....	8
Safety Icons.....	9

General Operation

Checks Before Each Start-Up	10
Starting The Engine.....	11
Operating The Snowthrower.....	12
Ground Speed Selector	12
Engine Speed.....	12
Deflector	13
Scraper Bar & Skid Shoes.....	13
Easy-Turn and Traction Drive Lock.....	14
Storage	15

Regular Maintenance

Schedule.....	16
Checking Tire Pressure	16
Checking Auger Gear Case Lubrication	16
Lubrication	17

Troubleshooting, Adjustments, & Service

Troubleshooting	18
Speed Selector Adjustment	20
Auger Drive Tension	20
Traction Drive Tension	20
Manual Discharge Chute Adjustment	21
Electric Discharge Chute Adjustment.....	21
Easy Turn Cable Adjustment	22
Shear Pin Replacement.....	22
Belt Replacement	23

Specifications

Replacement Parts & Accessories

WARNING

You must read, understand and comply with all safety and operating instructions in this manual before attempting to set-up and operate your snowthrower.

Failure to comply with all safety and operating instructions can result in loss of machine control, serious personal injury to you and /or bystanders, and risk of equipment and property damage. The triangle in the text signifies important cautions or warnings which must be followed.

WARNING

Engine exhaust from this product contains chemicals known, in certain quantities, to cause cancer, birth defects, or other reproductive harm.

Safety Rules & Information



Read these safety rules and follow them closely. Failure to obey these rules could result in loss of control of unit, severe personal injury or death to you, or bystanders, or damage to property or equipment. The triangle  in text signifies important cautions or warnings which must be followed.

GENERAL OPERATION

- Read, understand, and follow all instructions in the manual and on the unit before starting.
- Only allow responsible adults, who are familiar with the instructions, to operate the unit (local regulations can restrict operator age).
- Clear the area of objects such as rocks, toys, wire, etc., which could be picked up and thrown.
- Be sure the area is clear of other people. Stop unit if anyone enters the area.
- Always look down and behind before and while travelling in reverse.
- Be aware of the discharge direction and do not point it at anyone. Do not point the discharge at glass enclosures, automobiles, or windows.
- Disengage all clutches (release drive and auger control levers) before starting the engine.
- Never leave a running unit unattended. Always disengage the auger and traction controls, stop engine, and remove keys.
- Stop engine before unclogging chute.
- Operate only in daylight or good artificial light.
- Do not operate the unit while under the influence of alcohol or drugs.
- Watch for traffic when operating near or crossing roadways.
- Use extra care when loading or unloading the unit into a trailer or truck.
- Keep in mind the operator is responsible for accidents occurring to other people or property.
- Data indicates that operators, age 60 years and above, are involved in a large percentage of power equipment-related injuries. These operators should evaluate their ability to operate the unit safely enough to protect themselves and others from injury.
- All operators should seek and obtain professional and practical instruction.
- Always wear substantial footwear and appropriate winter clothing. Wear foot-ware that improves traction on slippery slopes. DO NOT wear long scarves or loose clothing that could become entangled in moving parts.
- Before using, always visually check that all hardware is present, in-tact, and secure. Replace worn or damaged parts.
- Never operate the machine with defective guards, or without safety protective devices in place.
- Stop engine before: refuelling, removing an attachment, making adjustments (unless the adjustment can be made from the operator's position).
- Follow the manufacturer's recommendation for wheel weights or counterweights.
- Adjust skid shoe height to clear gravel or crushed rock surfaces.
- Do not touch snowthrower parts which may be hot from operation. Allow such parts to cool before attempting to service the unit.

SLOPE OPERATION



WARNING

Never operate on slopes greater than 17.6 percent (10°) which is a rise of 3-1/2 feet (106 cm) vertically in 20 feet (607 cm) horizontally.

When operating on slopes use additional wheel weights or counterweights. See your dealer to determine which weights are available and appropriate for your unit.

Select slow ground speed before driving onto slope. Travel UP and DOWN the slope, never across the face, use caution when changing directions and DO NOT START OR STOP ON SLOPE.

Slopes are a major factor related to loss-of-control and tip-over accidents, which can result in severe injury or death. All slopes require extra caution. If you cannot back up the slope or if you feel uneasy on it, do not operate on it.

Do

- See your authorized dealer for recommendations counterweights to improve stability.
- Travel up and down slopes, not across.
- Remove obstacles such as rocks, tree limbs, etc.
- Watch for holes, ruts, or bumps. Uneven terrain could overturn the unit. Snow can hide obstacles.
- Use slow speed. Tires may lose traction on slopes. Choose a low gear so that you will not have to stop or shift while on the slope.
- Keep all movement on the slopes slow and gradual. Do not make sudden changes in speed or direction.
- Always keep unit in gear especially when traveling downhill.

Do Not

- Do not start or stop on a slope. If tires lose traction, disengage the auger and proceed slowly straight down the slope.
- Do not turn on slopes unless necessary, and then, turn slowly and gradually downhill, if possible.
- Do not operate near drop-offs, ditches, or embankments. The unit could suddenly turn over if a wheel is over the edge of a cliff or ditch, or if an edge caves in.
- Do not operate on wet surfaces. Reduced traction could cause sliding.
- Do not shift to neutral and coast down hills.

CHILDREN

Tragic accidents can occur if the operator is not alert to the presence of children. Children are often attracted to the unit and the operating activity. Never assume that children will remain where you last saw them.

- Keep children out of the area and under the watchful care of another responsible adult.
- Be alert and turn unit off if children enter the area.
- Before and during reverse operation, look behind and down for small children.
- Never allow children to operate the unit.
- Use extra care when approaching blind corners, shrubs, trees, or other objects that may obscure vision.

EMISSIONS

- Engine exhaust from this product contains chemicals known, in certain quantities, to cause cancer, birth defects, or other reproductive harm.
- Look for the relevant Emissions Durability Period and Air Index information on the engine emissions label.

SERVICE AND MAINTENANCE

- Use extra care in handling gasoline and other fuels. They are flammable and vapors are explosive.
 - a) Use only an approved container.
 - b) Never remove gas cap or add fuel with the engine running. Allow engine to cool before refueling. Do not smoke.
 - c) Never refuel the unit indoors.
- If fuel is spilled, do not attempt to start the engine but move the machine away from the area of spillage and avoid creating any source of ignition until fuel vapors have dissipated.
- Replace all fuel tank caps and fuel container caps securely.
- Never fill containers inside a vehicle or on a truck bed with a plastic bed liner. Always place containers on the ground away from your vehicle before filling.
- Remove gas-powered equipment from the truck or trailer and refuel it on the ground. If this is not possible, then refuel such equipment on a trailer with a portable container, rather than from a gasoline dispenser nozzle.
- Keep nozzle in contact with the rim of the fuel tank or container opening at all times until fueling is complete. Do not use a nozzle lock-open device.
- If fuel is spilled on clothing, change clothing immediately.
- Maintain or replace safety and instruction labels as necessary.
- Never run a unit in an enclosed area.
- Keep nuts and bolts tight and keep equipment in good condition.
- Never tamper with safety devices. Check their proper operation regularly and make necessary repairs if they are not functioning properly.
- Keep unit free of debris build-up. Clean up oil or fuel spillage.
- Stop and inspect the equipment if you strike an object. Repair, if necessary, before restarting.
- Never make adjustments or repairs with the engine running unless specified otherwise in the engine manufacturer's manual.
- Components are subject to wear, damage, and deterioration. Frequently check components and replace with manufacturer's recommended parts, when necessary.
- Check control operation frequently. Adjust and service as required.
- Use only factory authorized replacement parts when making repairs.
- Always comply with factory specifications on all settings and adjustments.
- Only authorized service locations should be utilized for major service and repair requirements.
- Never attempt to make major repairs on this unit unless you have been properly trained. Improper service procedures can result in hazardous operation, equipment damage and voiding of manufacturer's warranty.
- Do not change engine governor settings or over-speed the engine. Operating the engine at excessive speed can increase the hazard of personal injury.
- Disengage auger and traction, stop the engine, remove the key, and disconnect the spark plug wire(s) before: clearing blockages and chutes, performing service work, striking an object, or if the unit vibrates abnormally. After striking an object, inspect the machine for damage and make repairs before restarting and operating the equipment.

Safety Rules

ANSI B71.3-1995 WARNINGS

Training

1. Read the operating and service instruction manual carefully. Be thoroughly familiar with the controls and the proper use of the equipment. Know how to stop the unit and disengage the controls quickly.
2. Never allow children to operate the equipment. Never allow adults to operate the equipment without proper instruction.
3. Keep the area of operation clear of all persons, particularly small children and pets.
4. Exercise caution to avoid slipping or falling especially when operating in reverse.

Preparation

1. Thoroughly inspect the area where the equipment is to be used and remove all doormat, sleds, boards, wires, and other foreign objects.
2. Disengage all clutches and shift into neutral before starting engine (motor).
3. Do not operate the equipment without wearing adequate winter outer garments. Wear footwear that will improve footing on slippery surfaces.
4. Handle fuel with care; it is highly flammable.
 - (a) Use an approved fuel container.
 - (b) Never add fuel to a running engine or hot engine.
 - (c) Fill fuel tank outdoors with extreme care. Never fill fuel tank indoors.
 - (d) Replace fuel cap securely and wipe up spilled fuel.
5. Use extension cords and receptacles as specified by the manufacturer for all units with electric drive motors or electric starting motors.
6. Adjust the collector housing height to clear gravel or crushed rock surfaces.
7. Never attempt to make any adjustments while the engine (motor) is running (except when specifically recommended by the manufacturer).
8. Let engine (motor) and machine adjust to outdoor temperatures before starting to clear snow.
9. Always wear safety glasses or eye shields during operation or while performing an adjustment or repair to protect eye from foreign objects that may be thrown from the machine.

Operation

1. Do not put hands or feet near or under rotating parts. Keep clear of the discharge opening at all times.
2. Exercise extreme caution when operating on or crossing gravel drives, walks, or roads. Stay alert for hidden hazards or traffic.
3. After striking a foreign object, stop the engine (motor), remove the wire from the spark plug, disconnect the cord on electric motors, thoroughly inspect the snowthrower for any damage, and repair the damage before restarting and operating the snowthrower.
4. If the unit should start to vibrate abnormally, stop the engine (motor) and check immediately for the cause. Vibration is generally a warning of trouble.
5. Stop the engine (motor) whenever you leave the operating position, before unclogging the collector/impeller housing or discharge guide, and when making any repairs, adjustments, or inspections.

6. When cleaning, repairing, or inspecting make certain the collector/impeller and all moving parts have stopped. Disconnect the spark plug wire and keep the wire away from the plug to prevent accidental starting.
7. Do not run the engine indoors except for starting the engine or for transporting the snowthrower in or out of the building. Open the outside doors; exhaust fumes are dangerous.
8. Do not clear snow across the face of slopes. Exercise extreme caution when changing direction on slopes. Do not attempt to clear steep slopes.
9. Never operate the snowthrower without proper guards plates, or other safety protective devices in place.
10. Never operate the snowthrower near glass enclosures, automobiles, window wells, drop-offs, and the like without proper adjustment of the discharge angle. Keep children and pets away.
11. Do not overload the machine capacity by attempting to clear snow at too fast a rate.
12. Never operate the machine at high transport speeds on slippery surfaces. Look behind and use care when backing.
13. Never direct discharge at bystanders or allow anyone in front of the unit.
14. Disengage power to the collector/impeller when snowthrower is transported or not in use.
15. Use only attachments and accessories approved by the manufacturer of the snowthrower (such as wheel weights, counterweights, cabs, and the like).
16. Never operate the snowthrower without good visibility or light. Always be sure of your footing, and keep a firm hold on the handles. Walk, never run.

Maintenance and Storage

1. Check shear bolts and other bolts at frequent intervals for proper tightness to be sure the equipment is in safe working condition.
2. Never store the machine with fuel in the fuel tank inside a building where ignition sources are present such as hot water and spacer heaters, clothes dryers, and the like. Allow the engine to cool before storing in any enclosure.
3. Always refer to the operator's guide instructions for important details if the snowthrower is to be stored for an extended period.
4. Maintain or replace safety and instruction labels as necessary.
5. Run the machine a few minutes after throwing snow to prevent freeze-up of the collector/impeller.
 - Always observe safe refueling and fuel handling practices when refueling the unit after transportation or storage.
 - Always follow the engine manual instructions for storage preparations before storing the unit for both short and long term periods.
 - Always follow the engine manual instructions for proper start-up procedures when returning the unit to service.

DECALS

This unit has been designed and manufactured to provide you with the safety and reliability you would expect from an industry leader in outdoor power equipment.

Although reading this manual and safety instructions it contains will provide you with the necessary basic knowledge to operate this equipment safely and effectively, we have placed several safety labels on the unit to remind you of this important information while you are operating your unit.

All WARNING, CAUTION, and instructional messages on your unit should be carefully read and obeyed. Personal bodily injury can result when these instructions are not followed. The information is for your safety and it is important.

The safety decals below are on your unit.

If any of these decals are lost or damaged, replace them at once. See your local dealer for replacements.

These labels are easily applied and will act as a constant visual reminder to you, and others who may use the equipment, to follow the safety instructions necessary for safe, effective, operation.

NOTE: Engine operation and safety decals are supplied by the engine manufacturer.

NORTH AMERICAN MODEL DECALS



Part No. 1720674
WARNING / Main Dash Decal, North American Models



Part No. 1722674
Discharge Chute Danger Decal

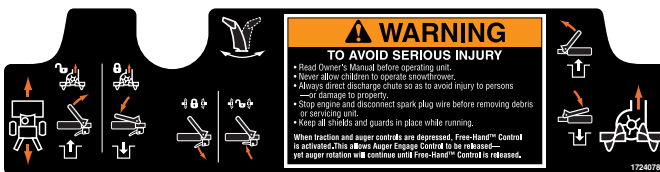

Part No. 1724078
WARNING / Main Dash Decal, North American Models



Part No. 1716532
Auger Danger Decal

CE MODEL DECALS



Part No. 1722688
WARNING / Main Dash Decal, CE Models



Part No. 1722642
Auger Danger Decal



Part No. 1722641
Discharge Chute Danger Decal

Safety Icons

SAFETY ICONS

WARNING: READ OPERATOR'S MANUAL.

Read and understand the Operator's Manual before using this machine.



WARNING: DISMEMBERMENT.

This machine can amputate limbs. Keep bystanders and children away when engine is running.



DANGER: THROWN OBJECTS.

This machine is capable of throwing objects and debris. Keep bystanders away.



DANGER: DISMEMBERMENT.

The auger can amputate limbs. Keep hands and feet away from auger and rotating parts.



WARNING: REMOVE KEY BEFORE SERVICING.

Remove the key, disconnect spark plug wire, and consult technical literature before performing repairs or maintenance.



DANGER: DISMEMBERMENT.

The impeller can amputate limbs. Stop the engine, remove the key, and disconnect spark plug wire before clearing the discharge chute or performing service work. Keep hands and feet away from impeller and rotating parts.



Identification Numbers



North American Models

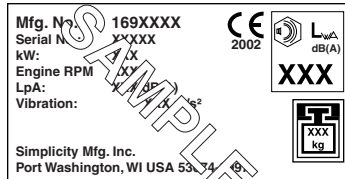
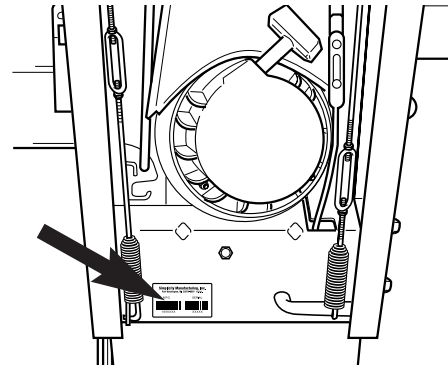

CE Models

When contacting your authorized dealer for replacement parts, service, or information you **MUST** have these numbers.

Record your model name/number, manufacturer's identification numbers, and engine serial numbers in the space provided for easy access. These numbers can be found in the locations shown.

NOTE: For location of engine identification numbers, refer to the engine owner's manual.

CE Models: Place the extra copy of the identification tag in the manual

PRODUCT REFERENCE DATA	
Model Description Name/Number	
Unit MFG Number	Unit SERIAL Number
Mower Deck MFG Number	Mower Deck SERIAL Number
Dealer Name	Date Purchased
ENGINE REFERENCE DATA	
Engine Make	Engine Model
Engine Type/Spec	Engine Code/Serial Number

CE IDENTIFICATION TAG MARKINGS

- A. Manufacturer's Identification Number
- B. Manufacturer's Serial Number
- C. Power Rating in Kilowatts
- D. Maximum Engine Speed in Rotations per Minute
- E. Manufacturer's Address
- F. Year of Manufacture
- G. CE Compliance Logo
- H. Mass of Unit in Kilograms
- I. Sound Power in Decibels ***
- J. Sound Pressure at Operator's Position in Decibels **
- K. Vibration*

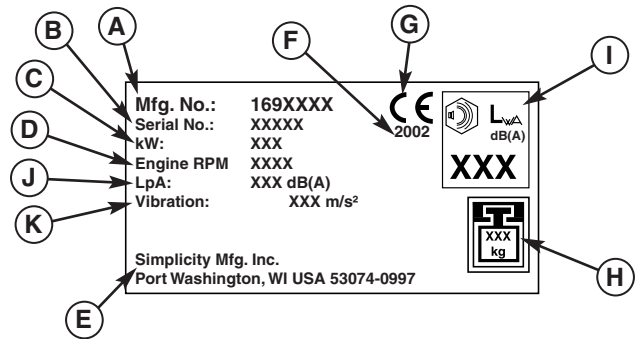

This unit complies with European Harmonized Lawn Mower Standard EN 836, European Machinery Directive 98/37/EC, and European EMC Directive 89/336/EC

* Tested according to EN 836:1997/A2:2001, EN 1032:1996, EN 1033:1995

** Tested according to EN836:1997/A2:2001

*** Tested according to 2000/14/EC

*CE Models:
Place copy of
Identification Tag here.*

Features, Controls, & Operation



TECUMSEH MODELS

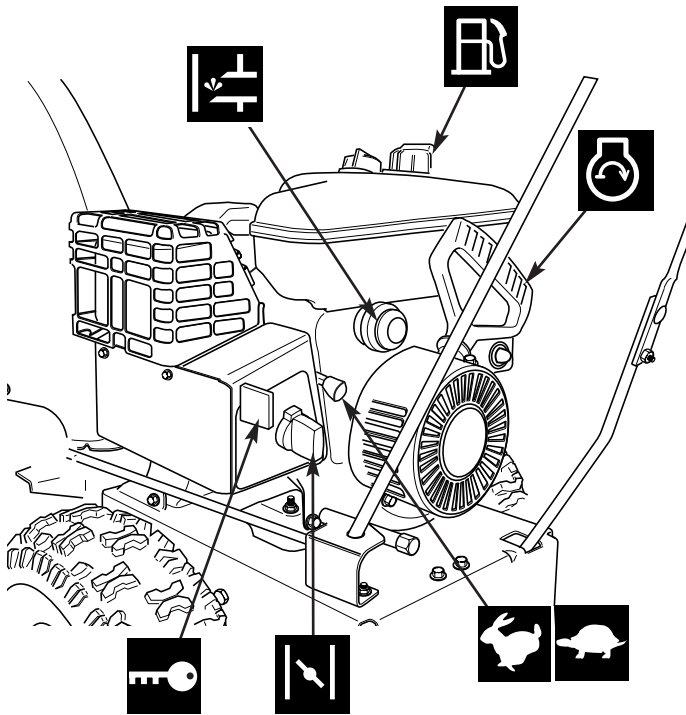

BRIGGS & STRATTON MODELS

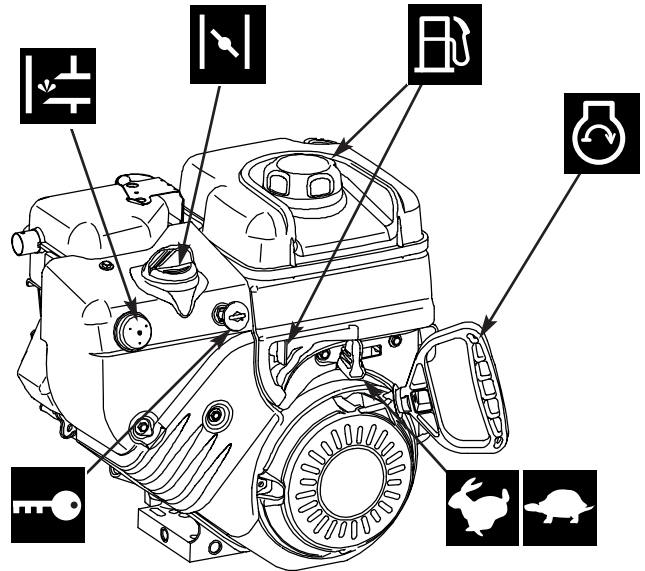

ALL MODELS

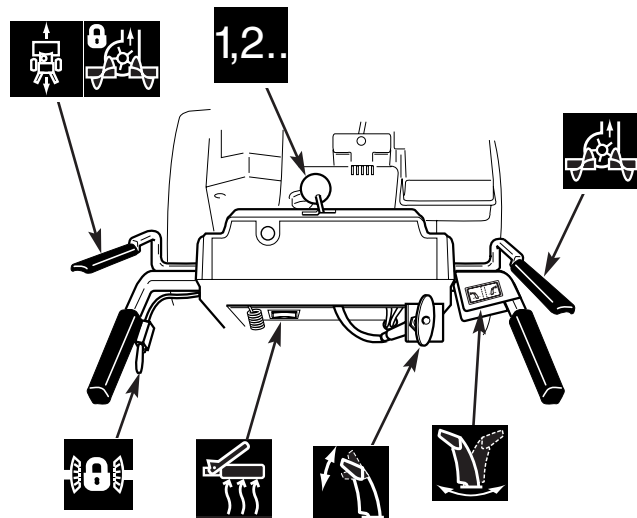

CONTROL LOCATIONS

The information below briefly describes the function of individual controls. Starting, stopping, and driving require the combined use of several controls applied in specific sequences. To learn what combination and sequence of controls to use for various tasks see the OPERATION section.

1,2.. Speed Selector

Selects forward speeds 1-5 and reverse speeds 1-2. No neutral position or gate is required, since the traction drive design automatically provides "neutral" (no forward or reverse movement), whenever the Drive Control is released.

Traction Control / Free Hand™ Lock

Engages traction drive to wheels when depressed. Also locks auger control when depressed simultaneously. Releasing the traction control lever releases the Free Hand™ auger control lock and stops the drive wheels.



Auger Control

Engages the auger/impeller when depressed. Releasing the control stops the auger/impeller.



Chute Direction Control

Models with Electric Chute Rotator: Depressing the chute rotator switch rotates the chute left or right.

Models with Manual Chute Rotator: Turning the crank rotates the discharge chute to desired position.



Remote/Regular Deflector Control

Regular (Knob) Chute Deflector: Locks chute deflector in desired position. Tilting the Chute Deflector UP provides a higher stream and greater distance, while tilting the deflector DOWN provides a lower stream and less distance.

Remote Chute Deflector: Twist the knob to unlock the chute deflector. Pull or push the knob to change the deflector angle. UP provides a higher stream and greater distance, while tilting the deflector DOWN provides a lower stream and less distance.



Easy Turn™ Control

Easy Turn Control: Engaging the Easy Turn™ lever releases the right wheel to allow easy turning in tight areas. Releasing the control automatically engages both drive wheels for full traction.

Traction Lock Pins: The right traction wheel can be completely released using the locking pin (see Figure 7). This allows the unit to be easily moved with the engine off.



Starter

Electric Start (If Equipped): Depressing the starter button activates the electric starter. The Electric Start Button operates on 120 Volts AC, which is provided by connection to the extension cord provided with units equipped with this feature. Connect this extension cord ONLY to a properly grounded 3 prong electrical outlet.

Recoil Starter (All Models): Pulling the recoil handle cranks the engine.



Fuel

Fuel tank filler cap (see illustration). Note: The fuel shut off valve is located under the fuel tank or on the front of the engine. Close the valve when the snowthrower is not in use. Open the valve before starting.



Primer Button

When pressed, the primer button provides initial fuel to help start a cold engine. Normally, pressing the primer button twice will provide enough fuel to start a cold engine.



Throttle Lever

Controls engine speed. Move toward the hare icon for faster engine speed, move toward the turtle icon for slower engine speed. Move the throttle all the way to STOP to stop the engine. Set throttle to FULL/FAST (hare icon) for operation.



Engine Key

The Engine Key prevents the engine from being started. The key must be fully inserted into the key slot for the unit to start. The key can also be used to stop the engine by pulling the key out of the key slot.



Choke Knob

The Choke Knob adjusts the air/fuel mixture, and is used to help start a cold engine by providing a richer mixture. Once the engine is warm and running smoothly, the Choke Knob should be set to the off position to provide a normal air/fuel mix.



Grip Warmers (Select Models)

The optional grip warmers are powered when the engine is running and have three settings: low, off, and high.



Headlight (Optional, Not Pictured)

For use in low sunlight - early morning and late evening. The headlight is on at all times when the engine is running.

Operation

GENERAL OPERATION

CHECKS BEFORE EACH START-UP

1. Make sure all safety guards are in place and all nuts, bolts and clips are secure.
2. Check the engine oil level. See your engine Owner's Manual for procedure and specifications.
3. Check to make sure spark plug wire is attached and spark plug is tightened securely. If necessary, torque spark plug to 15 ft. lbs.
4. Check the fuel supply. Fill the tank no closer than 1/4 to 1/2 inch of top of tank to provide space for expansion. See your engine Owner's Manual for fuel recommendations.
5. Check the Scraper Bar to make sure it is set at the desired height. Adjust the Skid Shoes if necessary.
6. Check the Drive Control (B, Figure 2), and Auger Control (C) for proper operation. If adjustment is required, see the Service section for procedures.
7. Check the Chute Direction Control (D, Figure 2) for proper operation. The discharge chute should rotate freely in both directions. See the Service section for adjustment procedures and troubleshooting.
8. Check the Chute Deflector (E, Figure 2) for proper operation. The deflector should pivot freely up and down when the Chute Deflector Knob is loosened.
9. Position the chute at the desired starting direction and set the deflector at the desired angle.
10. Check the Speed Selector (A, Figure 2) for smooth operation. The control must move freely into each speed position gate and remain in position when released. If the Speed Selector does not move freely into all forward and reverse speed positions, contact your local authorized dealer for assistance.

WARNING

This unit is a "two-stage" snowthrower.

The first stage is the auger, which feeds the snow back into the impeller housing. The second stage is the impeller, which throws the snow out the discharge chute. If bodily contact is made with the auger or impeller when they are rotating, severe personal injury will occur.

To avoid injury, keep others and yourself away from the auger and the discharge chute whenever the engine is running. Read and follow all of the safety rules and warnings in this manual.

WARNING

To avoid serious injury, do not put your hands into the auger housing or discharge chute. If auger stalls or chute becomes plugged, use the following procedure to remove objects or clear the chute:

1. Release both the Drive and Auger Control levers.
2. Shut off the engine.
3. Remove the Engine Key.
4. Wait for moving parts to stop.
5. Disconnect spark plug wire.
6. Use a narrow board to remove foreign objects and clear the chute or auger. Never put your hands into the auger or discharge chute.

WARNING

For your safety, operation on slopes should be in an up and down direction only. If it becomes necessary to move across the face of a slope, use caution and do not blow snow. Be very careful when changing direction on a slope.

Proper winter footwear is recommended for the operator to help prevent slipping. Never attempt to clean snow from excessively steep slopes. The maximum slope for any operation is 17.7% (10°).

WARNING

Gasoline is highly flammable and must be handled with care. Never fill the tank when the engine is hot or running. Always move outdoors to fill the tank. Keep snowthrower and gasoline away from open flame or spark.

STARTING THE ENGINE

1. Turn the fuel valve (located below the fuel tank) to the ON position.
2. Insert the Engine Key (F, Figure 1) into the Engine Key slot and push fully in to the RUN position.
3. Move the Throttle Lever (E) fully up to the FAST position.
4. Turn the Choke Knob (B) fully clockwise if engine is cold. (Do not choke a warm engine.)
5. Push the Primer Button (D) two times if engine is cold. (Do not prime a warm engine.)

6. **Engine Mounted Electric Start:** Press the starter button to crank the engine.

Manual Start: Pull Starter Handle (C) rapidly to start the engine. Do not allow the Starter Handle to snap back—let the starter rope rewind slowly—while keeping a firm grip on the Starter Handle.

7. As the engine starts and begins to operate evenly, turn the Choke Knob (B) slowly counter-clockwise to the OFF position, and set the Throttle Lever to SLOW. If the engine falters, turn the Choke Knob clockwise until the engine runs smoothly, and let it run briefly before returning the choke to the OFF position.

NOTE: Allow the engine to warm up at SLOW throttle for a few minutes before operating the snowthrower at full speed. The engine will not develop full power until it reaches operating temperature. After warming up, always operate at full throttle.

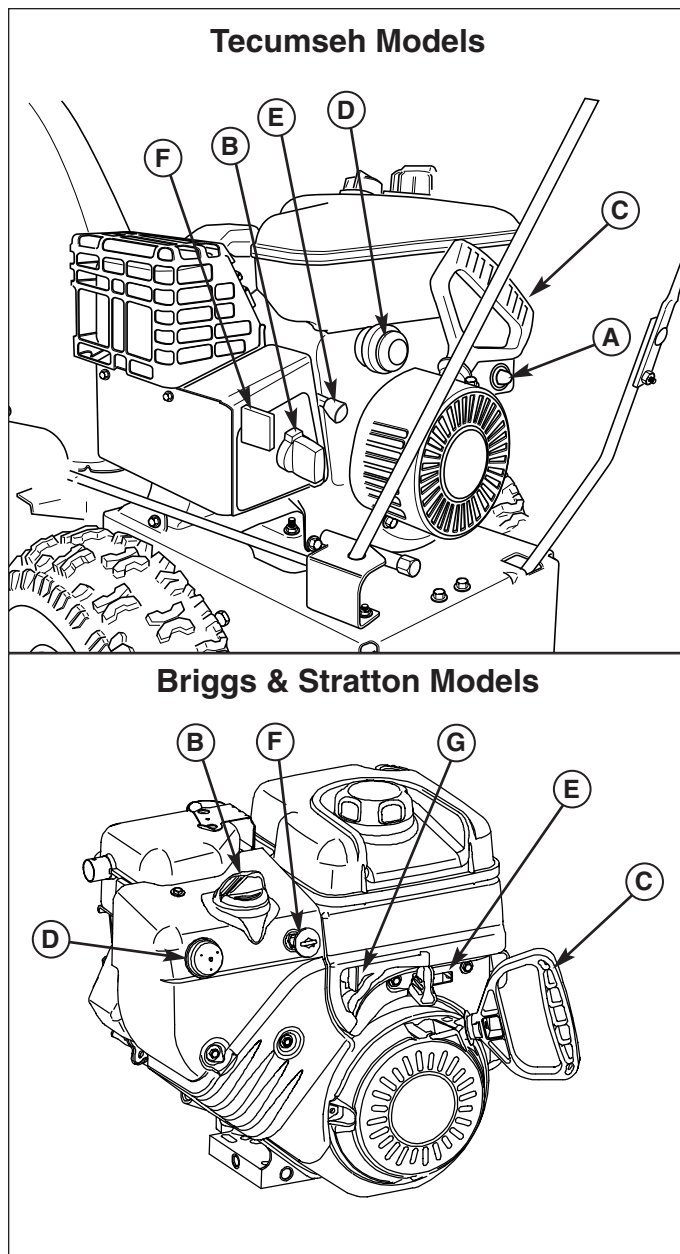

Figure 1. Engine Controls
A. Electric Start Button (Optional)
B. Choke Knob
C. Starter Handle
D. Primer Button
E. Throttle Lever
F. Engine Key
G. Fuel Valve

Operation

OPERATING THE SNOWTHROWER

1. Rotate the discharge chute to the desired direction.
2. Set the Speed Selector to the desired forward speed.
3. Fully press and hold the Auger Engage Control (C, Figure 2) on the right-hand grip to begin auger rotation. Releasing the Auger Engage Control will disengage the auger —**unless the Free-Hand™ Control has been activated (See step 5 below).**
4. Fully press and hold the Traction & Free-Hand™ Control lever (B, Figure 2) on the left-hand grip to engage the traction drive and begin moving the snowthrower. To disengage the traction drive, completely release the lever.
5. When BOTH levers are depressed, the Free-Hand™ Control is activated. This allows Auger Engage Control to be released — **YET AUGER ROTATION WILL CONTINUE — until the Free-Hand™ Control is released.**
6. Select forward or reverse speeds as needed using the Speed Selector (A, Figure 2). Release both control levers before changing drive speeds.

GROUND SPEED SELECTOR

Use the Speed Selector (A, Figure 2) to control the drive speed of the snowthrower. There are five forward speeds and two reverse speeds.

Use the lower speeds to blow deep or wet snow. Use the higher speeds to blow light snow or to drive the snowthrower without blowing snow.

To change speeds, release both control levers (B, Figure 2), then move the Speed Selector to the desired setting. Fully depress the control levers to resume.

ENGINE SPEED

Always run the snowthrower at full throttle.

WARNING

When BOTH levers are depressed, the Free-Hand™ Control is activated. This allows Auger Engage Control to be released — **YET AUGER ROTATION WILL CONTINUE — until the Free-Hand™ Control is released.**

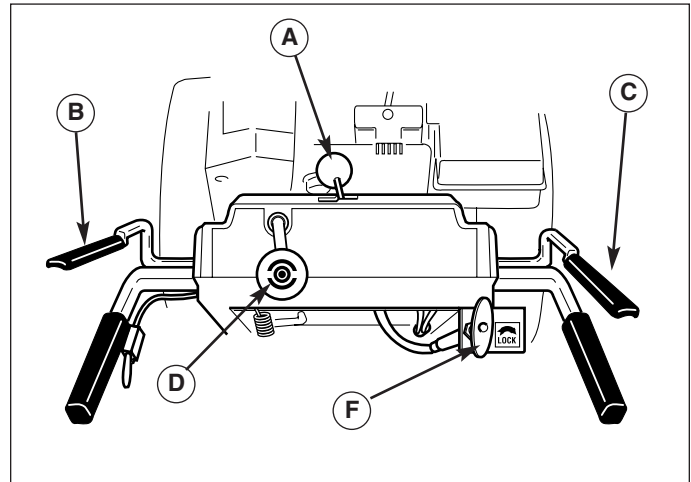

Figure 2. Controls (from operator's position)

- A. Speed Selector
- B. Traction & Free-Hand™ Control
- C. Auger Engage Control
- D. Chute Direction Control
- E. Chute Deflector (not shown)
- F. Remote Deflector Control

DEFLECTOR

The distance of the discharged snow is mainly controlled by the position of the deflector. (Engine speed also affects distance of discharge.) The more the deflector is tilted UP, the farther snow will be thrown.

Models with Chute Deflector Knob

See Figure 3.

1. Loosen the deflector knob, tilt the deflector UP or DOWN.
2. Retighten the knob when desired angle has been chosen.

Models with Remote Deflector Control

See Figure 4.

1. Turn the Remote Deflector Control (C) counterclockwise to UNLOCK, and the spring (B) will pull the deflector to the maximum throwing position (A). Push the knob UP to decrease the throwing distance.
2. Turn the Remote Deflector Control knob clockwise to LOCK in place when the desired angle has been chosen.

SCRAPER BAR & SKID SHOES

On smooth surfaces such as concrete or asphalt, the scraper bar (A, Figure 5) should scrape the surface. On surfaces such as gravel, the scraper bar should be high enough so that it will not pick up gravel or debris.

The height of the scraper bar (A) is controlled by raising or lowering the skid shoes (B).

1. To raise the scraper bar height, rest the scraper bar (A) on a strip of wood equal in thickness to the desired height.
2. Make sure the scraper bar is parallel to the ground surface.
3. Loosen the skid shoe nuts (C) and let the skid shoes (B) drop to the surface.
4. Tighten the nuts (C), making sure the skid shoes are adjusted equally and are parallel to the surface.
5. To lower the height of the scraper bar, raise the skid shoes.
6. If the scraper bar becomes worn, it can be replaced by removing the hardware attaching it to the snowthrower.

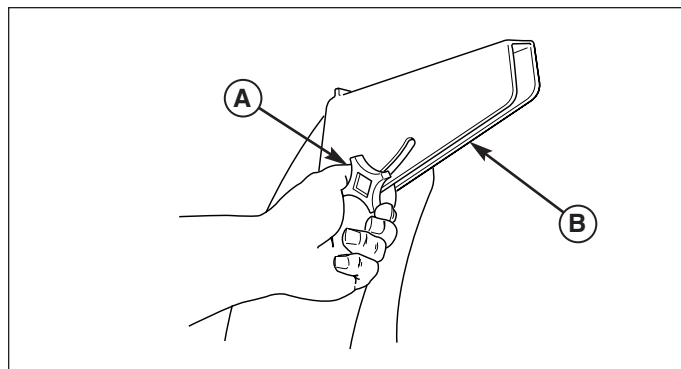

Figure 3. Chute Deflector Adjustment (Some Models)
A. Chute Deflector Knob
B. Chute Deflector

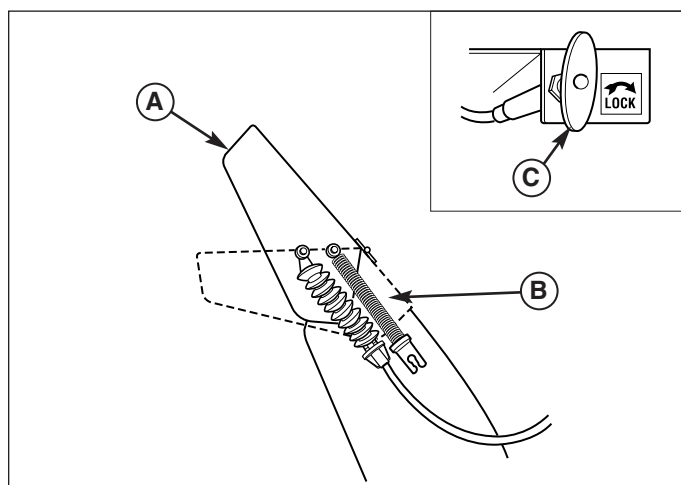

Figure 4. Remote Deflector Control (Some Models)
A. Maximum Throwing Position
B. Spring
C. Control Handle

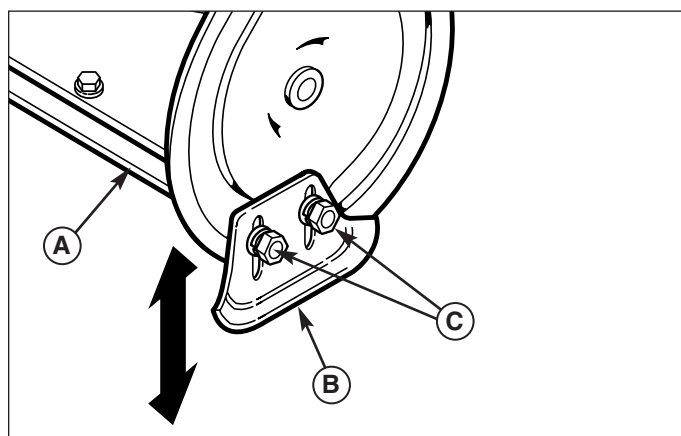

Figure 5. Skid Shoe Adjustment
A. Scraper Bar
B. Skid Shoe
C. Nuts

Operation

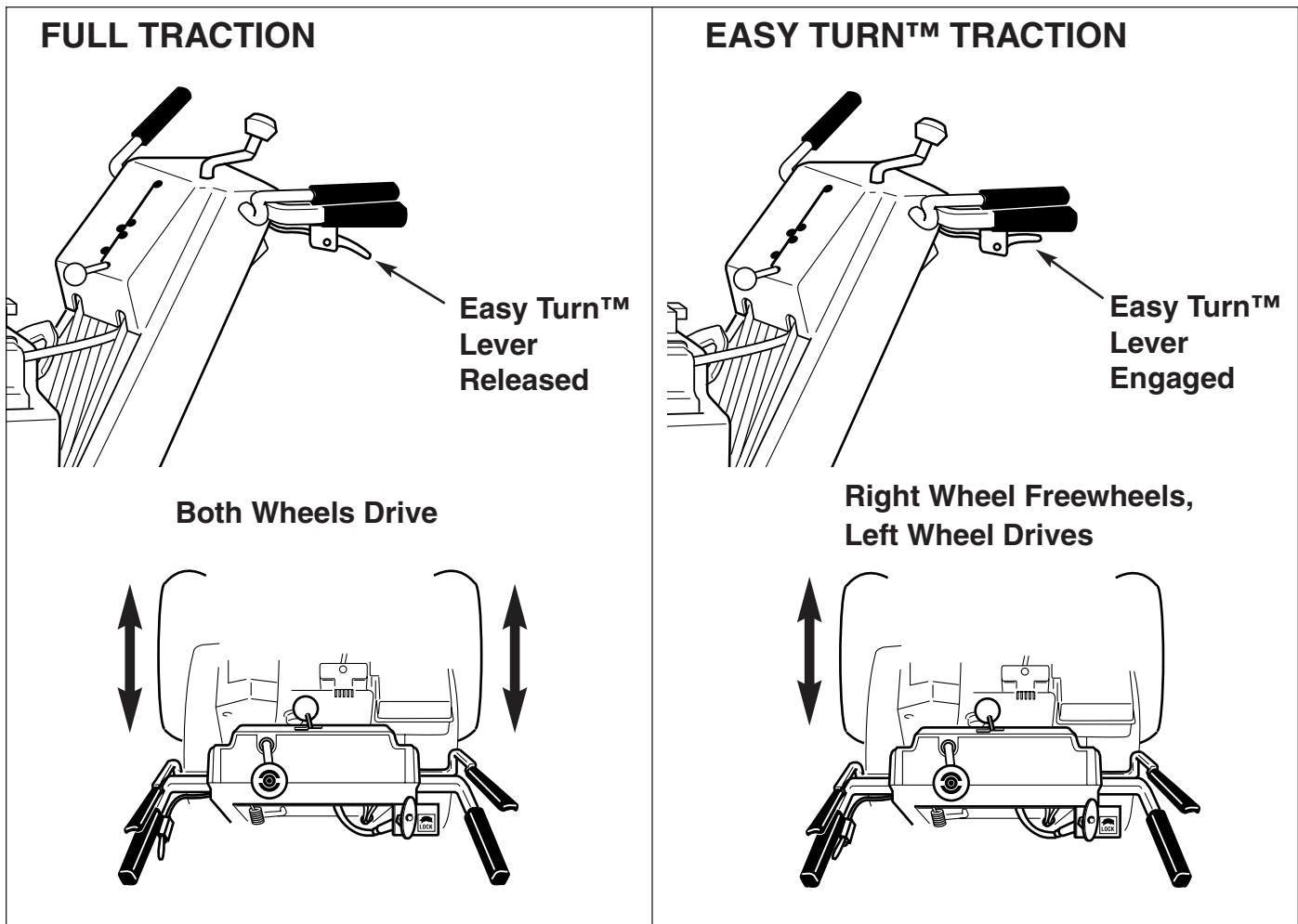

Figure 6. Easy Turn Control

EASY TURN™ FREEWHEELING AND TRACTION DRIVE LOCK

While Clearing Snow:

For easy turning when using the snowthrower, squeeze the Easy Turn™ lever (Figure 6). Engaging the Easy Turn™ lever releases the right traction wheel but allows the left wheel to continue driving (Figure 4). Releasing the Easy Turn™ lever automatically engages both drive wheels for full traction.

NOTE: The Easy Turn™ lever will be more difficult to activate under a heavy load. Activate the lever before beginning a turn.

When Pushing the Snowthrower:

For easy turning when pushing the snowthrower, disengage the right wheel using the Traction Lock Pin (See Figure 7.)

1. Turn the unit off, remove the Engine Key, and disconnect the spark plug wire.

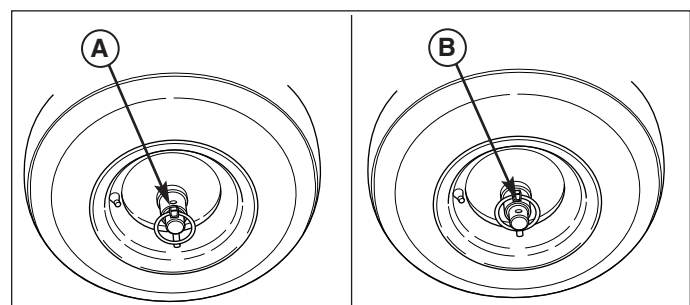

Figure 7. Traction Drive Lock

- A. Pin in Outer Hole (Freewheel)
- B. Pin in Inner Hole (Drive)

2. To DISENGAGE the traction drive lock, insert the Traction Lock Pin through the outer hole in the right axle. The unit can now be pushed with minimal resistance.
3. To ENGAGE the traction drive lock, align the hole in the hub with the inner hole in the axle, and install the Traction Lock Pin.

NOTE: Be sure both wheels are locked (locking pin in inner hole) when clearing snow.

TEMPORARY STORAGE (30 DAYS OR LESS)

Remember, the fuel tank will still contain some gasoline, so never store the unit indoors or in any other area where fuel vapor could travel to any ignition source. Fuel vapor is also toxic if inhaled, so never store the unit in any structure used for human or animal habitation.

Here is a checklist of things to do when storing your unit temporarily or in between uses:

- Keep in an area away from where children may come into contact with it. If there's any chance of unauthorized use, remove the spark plug (s) and put in a safe place. Be sure the spark plug opening is protected from foreign objects with a suitable cover.
- If the unit can't be stored on a reasonable level surface, chock the wheels.
- Clean all debris and snow from the unit.

NOTE: If storing your unit between winter snow removal jobs in a cold area, we suggest that you fill the fuel tank at the completion of each job to prevent water condensation in the fuel tank. Wait for engine to cool before filling tank.

LONG TERM STORAGE (LONGER THAN 30 DAYS)

Before you store your unit for the off-season, read the Maintenance and Storage instructions in the Safety Rules section, then perform the following steps:

1. Drain crankcase oil and refill with a grade of oil that will be required when unit is used again.
2. Coat all bare metal surfaces with paint or light coat of oil to prevent rusting.
3. Clean external surfaces and engine.
4. Prepare engine for storage. See engine owner's manual.
5. Clean any dirt from the engine housing.
6. Cover air intake and exhaust outlet tightly with plastic or other waterproof material to keep out moisture, dirt and insects.
7. Completely grease and oil as outlined in the Normal Care section.
8. If equipped, be sure the battery is filled to the proper level with water and is fully charged. Battery life will be increased if it is removed, put in a cool, dry place and fully charged about once a month. If battery is left in, disconnect the negative cable.

WARNING

Never store the unit, with gasoline in engine or fuel tank, in a heated shelter or in enclosed, poorly ventilated enclosures. Gasoline fumes may reach an open flame, spark or pilot light (such as a furnace, water heater, clothes dryer, etc.) and cause an explosion.

Handle gasoline carefully. It is highly flammable and careless use could result in serious fire damage to your person or property.

Drain fuel into an approved container outdoors away from open flame or sparks.

10. Drain fuel system completely or add a gasoline stabilizer to the fuel system. If you have chosen to use a fuel stabilizer and have not drained the fuel system, follow all safety instructions and storage precautions in this manual to prevent the possibility of fire from the ignition of gasoline fumes. Remember, gasoline fumes can travel to distant sources of ignition and ignite, causing risk of explosion and fire.

NOTE: Gasoline, if permitted to stand unused for extended periods (30 days or more), may develop gummy deposits which can adversely affect the engine carburetor and cause engine malfunction. To avoid this condition, add a gasoline stabilizer to the fuel tank or drain all fuel from the system before placing unit in storage.

STARTING AFTER LONG TERM STORAGE

Before starting the unit after it has been stored for a long period of time, perform the following steps.

1. Remove any blocks from under the unit.
2. Install the battery if it was removed.
3. Unplug the exhaust outlet and air cleaner.
4. Fill the fuel tank with fresh gasoline. See engine manual for recommendations.
5. See engine owner's manual and follow all instructions for preparing engine after storage.
6. Check crankcase oil level and add proper oil if necessary.
7. Inflate tires to proper pressure.
8. Start the engine and let it run slowly. DO NOT run at high speed immediately after starting. Be sure to run engine only outdoors or in well ventilated area.

Regular Maintenance



MAINTENANCE SCHEDULE

Maintenance Required	Service Interval	Notes
Check auger gear case oil level*	25 Hours	Use Simplicity Winter Weight Worm Gear Oil
Lubricate snowthrower	10 Hours	Use 10W Oil and Automotive Lithium Grease
Check tire pressure	Monthly	Inflate to 20 psi (1.37 bar)
Check/Change engine oil**	Check oil before each use **	None
Replace spark plug**	Yearly**	None
Check drive linkage & belt tension	4-6 Hours	None

* If lubricant leaks out, have the unit inspected by your authorized dealer.
 ** See your engine owner's manual for engine-related information.

CHECKING TIRE PRESSURE

The air pressure in each tire (Figure 8) should be 20 psi (136 kPa) and should be equal for both tires for best performance. Be sure to keep caps on valves to prevent entry of debris into the valve stem when tires are filled.

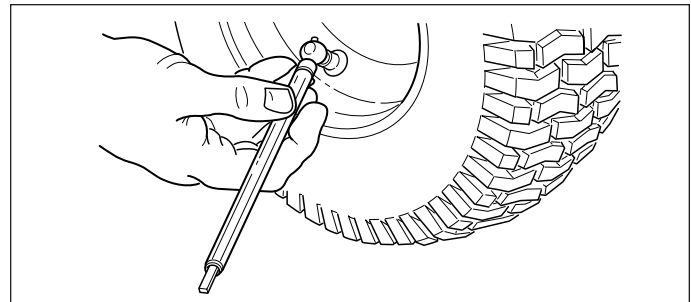

Figure 8. Checking Tire Pressure

AUGER GEAR CASE LUBRICATION

1. Place the snowthrower on a level surface.
2. Remove the pipe plug (A, Figure 9).
3. Check the lubricant level. It should be level with the lower edge of the plug opening. If not, add Simplicity Winter Weight Worm Gear Oil (available from your dealer).
4. Re-install pipe plug, and tighten securely.

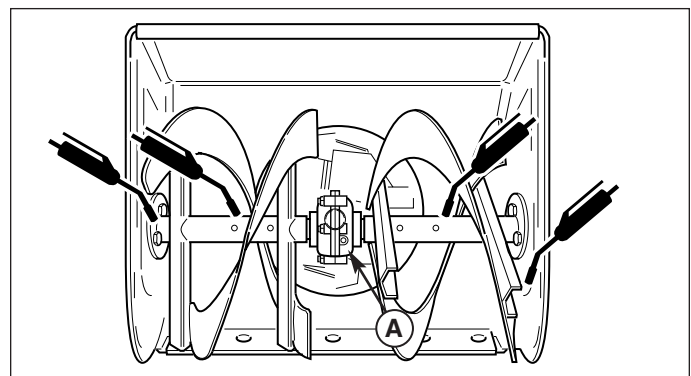

Figure 9. Auger Lubrication
A. Pipe Plug

LUBRICATION

IMPORTANT NOTE

It is very important that grease fittings on the auger shaft are lubricated regularly. If auger rusts to shaft, damage to worm gear may occur if shear pins do not break.

To prevent wheels rusting to axles, it is also necessary to remove the wheels and grease the axles regularly.

Remove wheels and grease axles once each year.

There are two grease fittings on the auger shaft (Figure 9). Wipe the fittings clean and apply grease, using a grease gun. Also apply grease on other points indicated.

Apply medium weight (10W) oil to points shown (See Figures 10-14).

Apply 5W-50 synthetic motor oil to the friction disk drive hex shaft (A, Figure 12).

Generally, all moving metal parts should be oiled where contact is made with other parts. Keep oil and grease off belts, pulley grooves, drive disc, and friction disc.

LUBRICATION NOTES:



Grease locations indicated by grease gun symbol. Use grease fittings when present. Disassemble parts to apply grease to moving parts when grease fittings are not installed.



Oil locations indicated by oil can symbol. Do not allow oil to drip onto traction drive or friction disc.

Do not lubricate Remote Deflector Control

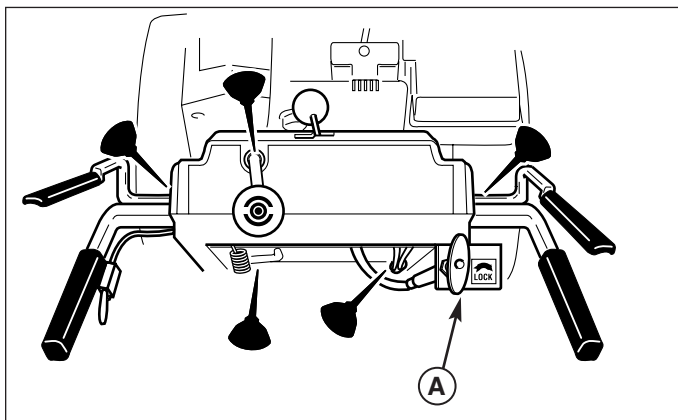

Figure 10. Lubricate Free-Hand™ Control Linkage
A. DO NOT Lubricate Deflector Control

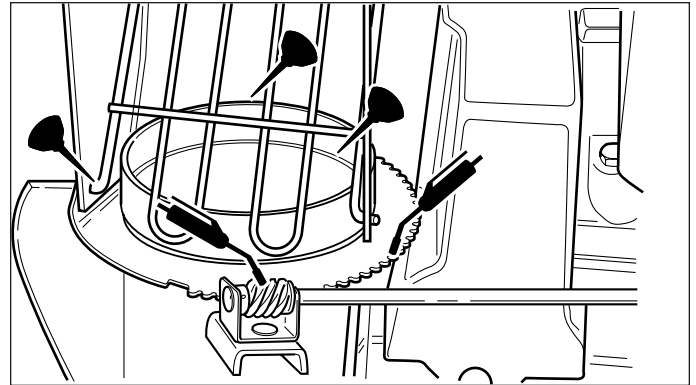

Figure 11. Chute Lubrication

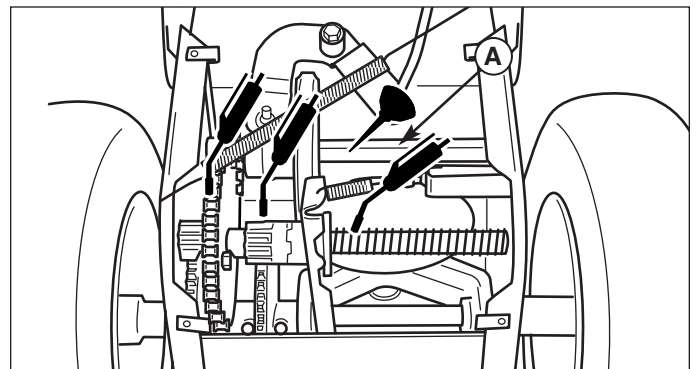

Figure 12. Drive Lubrication
A. Hex Shaft

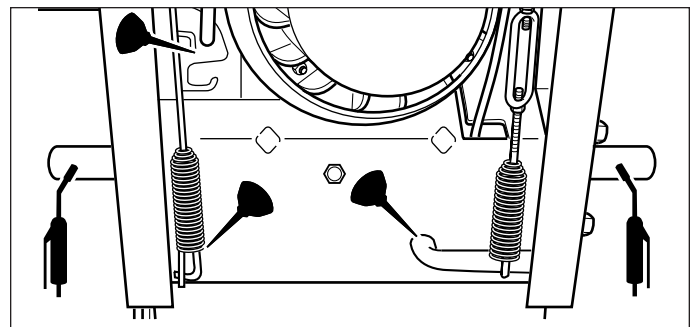

Figure 13. Grease Axles & Lubricate Control Levers

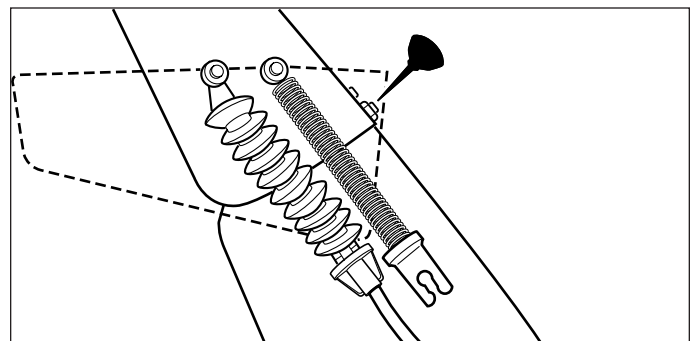

Figure 14. Lubricate Deflector Hinges

Troubleshooting, Adjustments, Service



TROUBLESHOOTING

This section provides troubleshooting and service instructions. Locate the problem and check the possible cause/remedy in the order listed.

Also, refer to the engine manufacturer's Owner's Manual for additional information.

For problems not covered here, contact your local dealer.

WARNING

Before performing any adjustment or service to snowthrower, stop the engine and wait for moving parts to stop. Remove the key. To prevent accidental starting, disconnect the spark plug wire and fasten away from the plug.

PROBLEM	POSSIBLE CAUSE	REMEDY
Engine fails to start.	1. Key is OFF.	1. Push key in to the ON position.
	2. Failure to Prime cold Engine	2. Press Primer Button twice and restart.
	3. Fuel valve is in CLOSED position.	3. Turn valve to OPEN position.
	4. Out of fuel.	4. Fill fuel tank.
	5. Choke OFF - cold engine.	5. Turn choke to ON, set throttle to FAST.
	6. Engine flooded.	6. Turn choke to OFF; try starting.
	7. No spark.	7. Check gap. Gap plug, clean electrode, or replace plug as necessary.
	8. Water in fuel, or old fuel.	8. Drain tank (Dispose of fuel at an authorized hazardous waste facility). Fill with fresh fuel.
Engine starts hard or runs poorly.	1. Fuel mixture too rich.	1. Move choke to OFF position.
	2. Carburetor adjusted incorrectly.	2. See your dealer for adjustments.
	3. Spark plug faulty, fouled, or gapped improperly.	3. Clean and gap, or replace.
	4. Fuel Cap Vent is blocked.	4. Clear vent.
Scraper bar does not clean hard surface.	1. Skid Shoes improperly adjusted.	1. RAISE Skid Shoes (this lowers the Scraper Bar).
	1. Skid shoes improperly adjusted.	1. LOWER Skid Shoes (this raises the scraper bar.)
Auger does not rotate.	1. Auger Control not engaged.	1. Engage Auger Control.
	2. Foreign matter blocking auger.	2. STOP engine and REMOVE the key. DISCONNECT the spark plug wire. Clear auger using a narrow board. See warning in SAFETY RULES.
	3. Auger drive clutch rod slack.	3. Tighten to remove slack. See auger clutch rod adjustment.
	4. Auger drive belt slipping.	4. Check auger drive belt adjustment.
	5. Broken belt.	5. Replace belt.
	6. Shear pin broken.	6. Replace shear pin.

Troubleshooting

PROBLEM	POSSIBLE CAUSE	REMEDY
Auger rotates, but snow is not thrown far enough	1. Chute Deflector too low.	1. Adjust deflector as necessary.
	2. Engine speed too slow.	2. Set speed to full throttle.
	3. Ground speed too fast.	3. Use slower Speed Selector setting.
	4. Snowthrower discharge chute clogged.	4. STOP engine and REMOVE the key. DISCONNECT the spark plug wire. Clear auger using a narrow board. See warning in SAFETY RULES.
	5. Auger belt loose or worn.	5. Check Auger Drive Belt Adjustment
Poor traction	1. Tires slipping.	1. Check tire pressure and tread.
Auger does not stop when auger lever is released	1. Free-Hand™ Control is ACTIVE.	1. Release BOTH Auger Engage Control AND Free-Hand™ Control to stop auger.
	2. Auger clutch rod too tight or bent.	2. Loosen or straighten clutch rod.
	3. Auger drive belt out of adjustment.	3. Adjust auger belt.
	4. Auger belt guide out of adjustment.	4. Adjust auger belt guide.
Snowthrower does not stop when drive lever is released	1. Traction drive clutch rod bent or too tight.	1. Loosen rod to remove slack or replace. See adjustment procedure.
	1. Traction drive clutch rod loose.	1. Tighten to remove slack. See adjustment procedure.
	2. Drive belt loose, broken, or stretched.	2. Replace drive belt.
	3. Drive roller chain damaged.	3. Replace chain.
	4. Traction Lock Pins in Free-Wheeling position (OUTER hole).	4. Change Traction Lock Pins to INNER hole to engage traction drive.
5. Friction Disc worn.	5. Replace Disc (see your dealer).	
Discharge control is difficult to operate.	1. Gearing needs lubrication	1. Oil or grease as required.
	2. Worm gear not adjusted properly.	2. Adjust worm gear. See adjustment procedure.
	3. Control rod gears misaligned.	3. Adjust gear bracket. See adjustment procedure.
Snowthrower veers to one side.	1. Tires pressure not equal.	1. Check tire pressure.
	2. One wheel is set in Free-Wheeling mode. (Traction Lock Pin is in the OUTER hole).	2. Make certain the left Traction Lock Pin is in the INNER holes (to engage traction drive).
Excessive vibration.	1. Loose parts or damaged auger.	1. STOP engine and REMOVE the key. DISCONNECT the spark plug wire. Tighten all hardware. Replace auger if necessary. If vibration continues, see your dealer.
Drive fails to move snowthrower at slow speeds.	1. Traction Drive out of adjustment.	1. Readjust drive, or shift Speed Selector setting up one speed faster.
Speed selector difficult to move or frozen in place.	1. Hex shaft needs lubrication.	1. Lubricate hex shaft with 5W-50 synthetic motor oil (see Maintenance).

Adjustments

SPEED SELECTOR ADJUSTMENT

1. Loosen the two nuts (F, Figure 15).
2. Place the shift lever in 5th gear.
3. Push the lower rod into the housing and tighten the two nuts. Do not lift up or down on rods while tightening. Make sure the shoulders of the carriage bolts (D) are in the slots.
4. Always check traction drive tension and auger drive tension after adjusting speed selector.

AUGER DRIVE TENSION

1. With the drive lever released, the hook (B, Figure 15) should barely touch the lever (C) without raising it. There can be a maximum 1/32" clearance as shown.
2. To adjust, loosen the two nuts (G) and hold the lower rod to keep from rotating. Turn the turnbuckle toward the right to lower the spring, or toward the left to raise the spring.
3. Tighten the two nuts against the turnbuckle. Hold the turnbuckle with pliers while tightening the nuts.

TRACTION DRIVE TENSION

1. With the drive lever engaged, bottom end of lower rod (D, Figure 16) should be flush with bottom of spring (E).
2. To adjust, loosen the two nuts, (B) and hold the lower rod to keep from rotating. Turn the turnbuckle (C) toward the right to lower rod or toward the left to raise rod.
3. Engage the drive lever to check the adjustment. When correct, tighten the two nuts against the turnbuckle. Hold the turnbuckle with pliers while tightening the nuts.

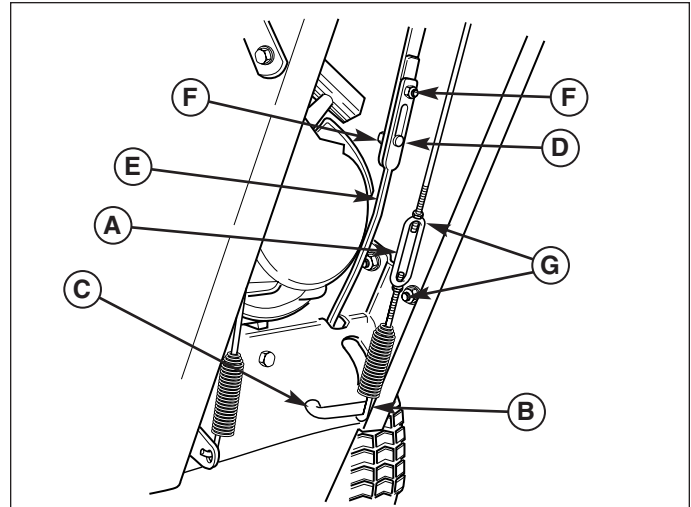

Figure 15. Speed Selector and Auger Drive Linkages

- A. Turnbuckle
- B. Spring Hook
- C. Lever
- D. Carriage Bolts
- E. Lower Rod
- F. Nuts
- G. Nuts

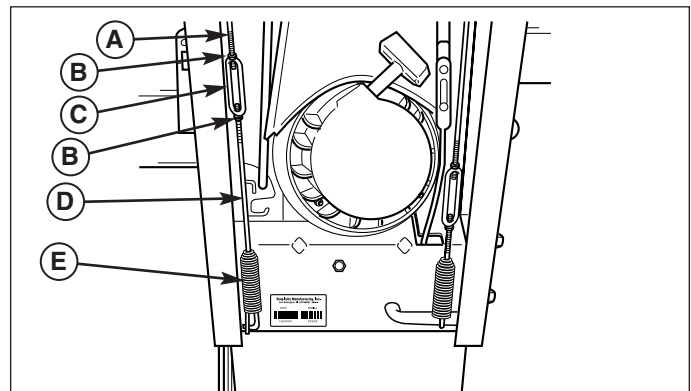

Figure 16. Drive Tension Adjustment

- A. Upper Rod
- B. Nuts
- C. Turnbuckle
- D. Lower Rod
- E. Spring

MANUAL DISCHARGE CHUTE CONTROL LINKAGE ADJUSTMENT

Pinion Gear Adjustment

If the discharge chute is difficult to operate, first lubricate the pinion gear (A, Figure 17) and ring gear (F). If it is still difficult to operate, adjust as follows:

NOTE: If the discharge chute will not stay in position, adjust the pinion gear (A) closer to the ring gear.

1. Loosen the nut (G, Figure 17) which holds the pinion gear bracket in the slotted hole.
2. If the pinion gear is too tight against the ring gear, move it away slightly and then retighten the nut.
3. Check the operation again

Gear Bracket Adjustment

If the Discharge Chute becomes difficult to rotate or begins to operate erratically, the Chute Direction Control rod gears may require adjustment:

1. Loosen the gear bracket mounting nuts (Figure 18).
2. Slide the gear bracket into the position that provides the best engagement between the gears.
3. Tighten the bracket mounting hardware, and check for smooth operation.
4. Readjust if necessary.
5. Lubricate the Chute Direction Control rod gears with a medium weight (10W) oil

ELECTRIC DISCHARGE CHUTE ROTATOR MOTOR ADJUSTMENT

If the electric chute rotator does not function properly, check the electrical connections and then perform the procedure below.

1. Remove the rotator motor cover.
2. Lubricate the chute ring gear.
3. Loosen the capscrews (A, Figure 19) securing the rotator motor and adjust so that the motor gear and chute ring gear mesh. Tighten the capscrews.
4. Reinstall the rotator motor cover.

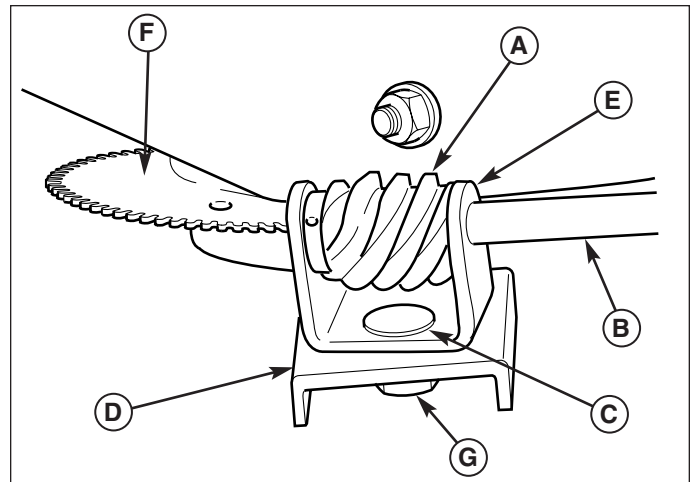

Figure 17. Discharge Control

- A. Pinion Gear
- B. Control Rod
- C. Carriage Bolt
- D. Slotted Bracket
- E. U-shaped Bracket
- F. Ring Gear
- G. Nut

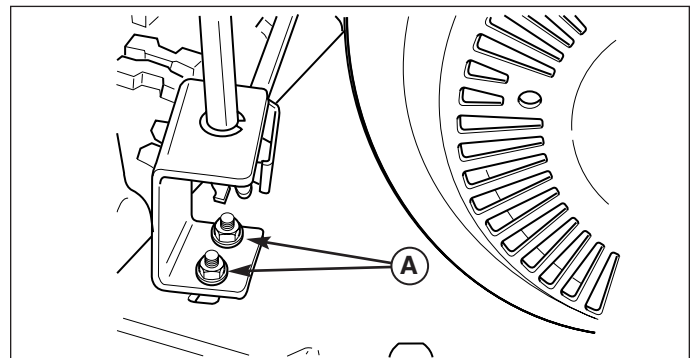

Figure 18. Gear Bracket Adjustment

- A. Mounting Hardware

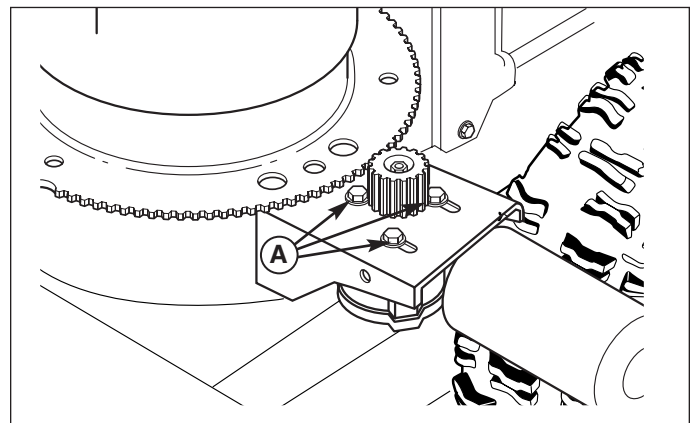

Figure 19. Chute Rotator Motor Adjustment

- A. Capscrews

Adjustments & Service

EASY TURN™ CABLE ADJUSTMENT

If the Easy Turn™ cable has stretched, the gears will not disengage when the control lever is activated. Adjust the cable using the following procedure.

1. Turn the engine off and disconnect the spark plug wire.
2. Loosen the jam nut (B, Figure 20).
3. Turn the adjustment nut (A) to lengthen or shorten the cable. The cable should be tightened just until all slack is removed from the lever, however it must not engage the Easy Turn™ release without depressing the control lever.
4. Tighten the jam nut.

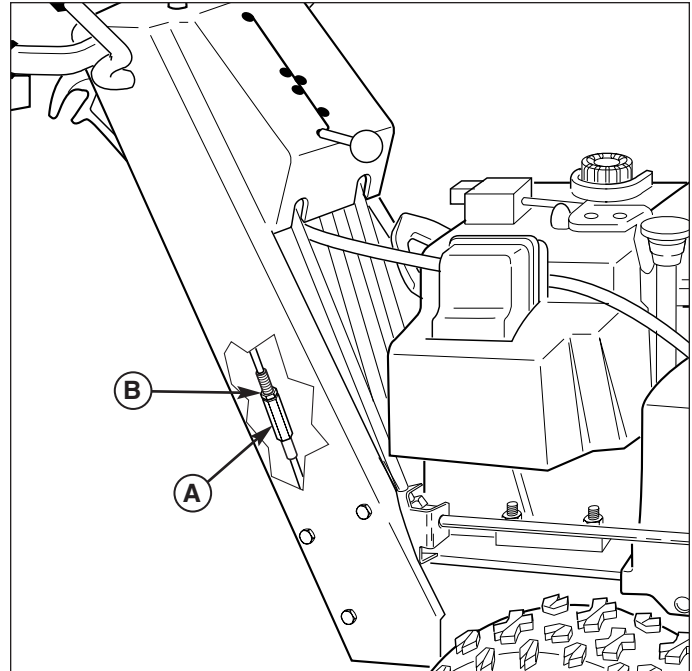

Figure 20. Cable Adjustment
A. Adjustment Nut
B. Jam Nut

SHEAR PIN REPLACEMENT

WARNING

Do not go near the discharge chute or auger when the engine is running. Do not run the engine with any cover or guard removed.

Under most circumstances, if the auger strikes an object which could cause damage to the unit, the shear pin will break. (This protects the gear box and other parts from damage.)

The shear pins are located on the auger shaft as shown in Figure 21. To replace the shear pins, tap out the broken pin with a pin punch, and install a new shear pin and cotter pin. Spread the legs of the new cotter pin fully. **Do NOT replace shear pins with anything other than the correct grade replacement shear pin.** (Use of bolts, screws or a harder shear pin will lead to damaged equipment.)

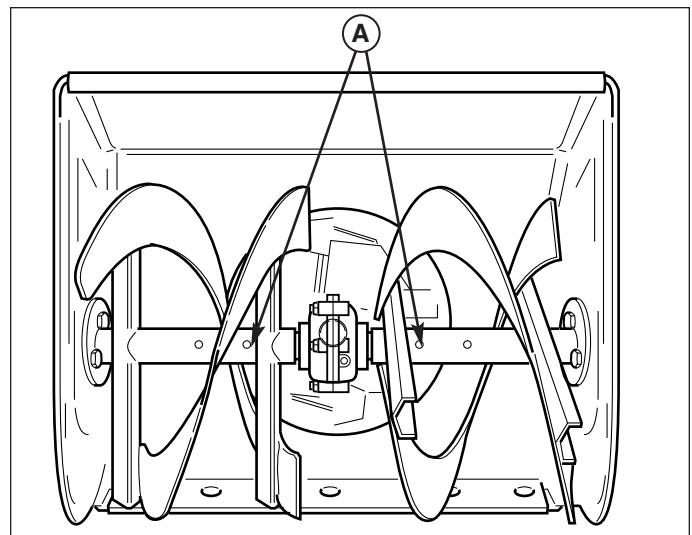

Figure 21. Shear Pins
A. Shear Pins

BELT REPLACEMENT

1. Turn off the engine, remove the spark plug wire, and wait for all moving parts to stop. Rotate the spout full right. Loosen the two screws (B, Figure 22) securing the belt cover.
2. Tilt the cover forward and work it off the snowthrower.
3. Move the belt guides (B, Figure 23) by loosening the two capscrews (A).
4. Remove the auger drive belt as follows:
 - a. Slip the auger drive belt (D, Figure 23) from the idler pulley by pushing it away from the pulley and then toward the rear.
 - b. Remove the belt from the engine pulley. Slip the belt from under the brake pad.
 - c. Remove six capscrews from bottom cover to snowthrower frame. Loosen nuts (A, Figure 24) on each side to release auger pulley belt stops (B). Move belt stops and remove belt from pulley (C).
 - d. Remove the two bolts (D, Figure 24) from the gear assembly.
 - e. Loosen the set collar and slide the axle shaft right.
 - f. Belt can be removed from top or bottom. For more clearance to remove the belt, engage the traction drive lever.
5. Remove the traction drive belt as follows:
 - a. Pull the idler pulley (I, Figure 23) away from the belt and slip the belt from the pulley.
 - b. Slip the belt off the traction pulley and then the engine pulley. The arm for the front idler pulley (G, Figure 23) may have to be pivoted to provide clearance for removing the belt from the traction pulley.
 - c. Pull the belt out between the auger pulley (F, Figure 23) and traction pulley.

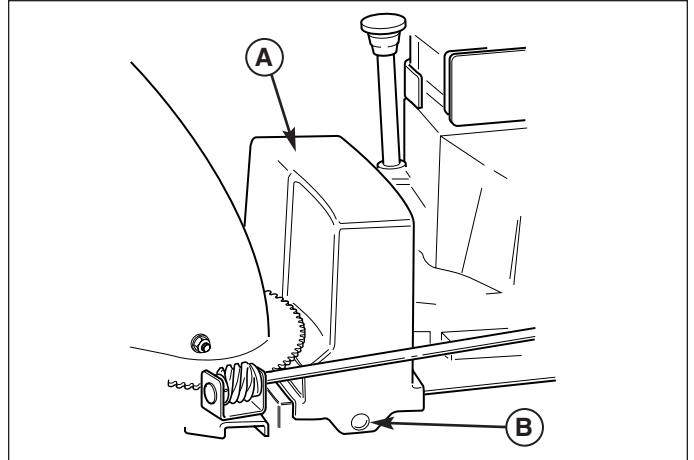

Figure 22. Belt Cover
A. Belt Cover
B. Screws

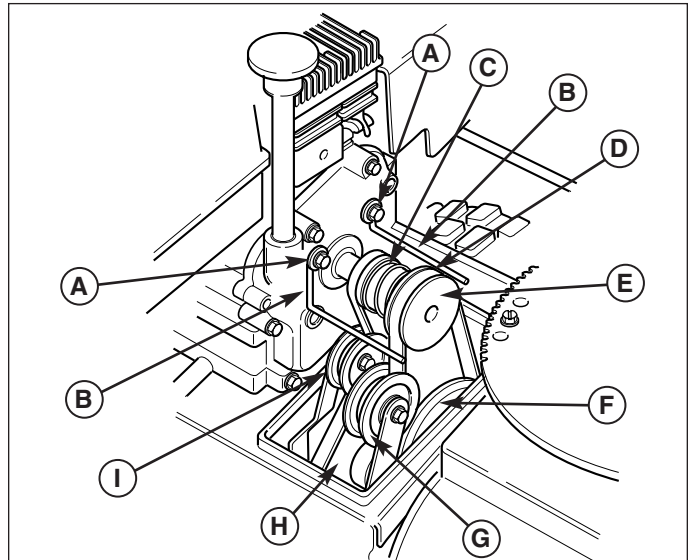

Figure 23. Belts and Pulleys
A. Capscrews
B. Belt Guides
C. Traction Drive Belt
D. Auger Drive Belt
E. Engine Pulley
F. Auger Pulley
G. Idler Pulley, Auger
H. Traction Pulley
I. Idler Pulley, Traction

Service

- Reverse the procedure to install the belts. Be sure there are no twists and the belts are properly seated in the grooves. Adjust the belt stops so there is 1/8" (3mm) clearance between belt and stop. The pattern for both belts is shown in Figure 25. Slide the right axle left fully before tightening the set collar (E, Figure 24).
- Check the traction drive tension and auger drive tension. Follow the procedures under AUGER/TRACTION DRIVE TENSION.
- Make sure the auger stops when the auger drive lever is released. Make sure traction drive stops when the traction drive lever is released. If not, check the drive tension. If a problem exists, see your dealer.

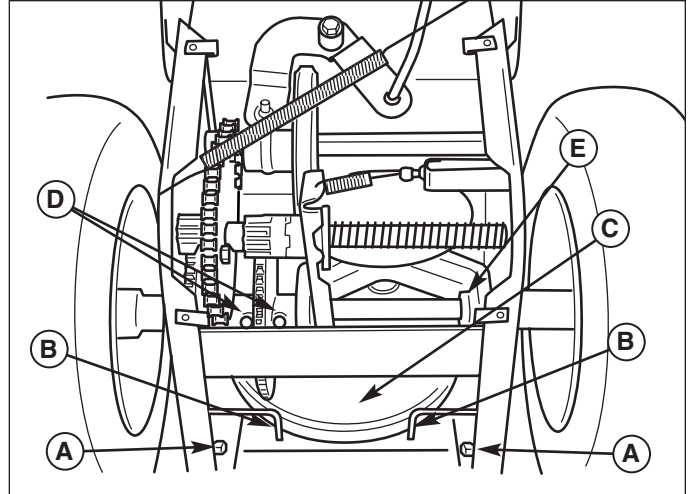

Figure 24. Auger Pulley Belt Stops (shown with bottom cover removed)

- A. Nuts
- B. Belt Stops
- C. Auger Pulley
- D. Gear Assy. Bolts
- E. Set Collar

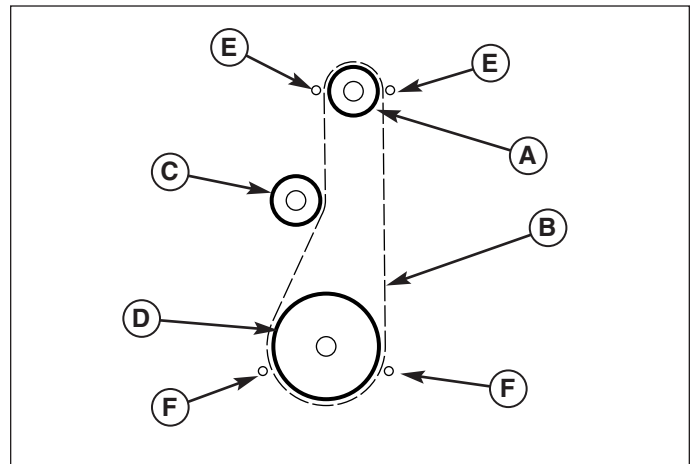
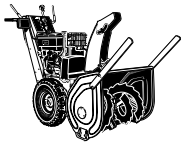

Figure 25. Belt Pattern (viewed from front)

- A. Engine Pulley
- B. Drive Belt
- C. Idler Pulley
- D. Driven Pulley
- E. Engine Belt Stops
- F. Auger Pulley Belt Stops



Specifications

NOTE: Specifications are correct at time of printing and are subject to change without notice.

** Actual sustained equipment horsepower will likely be lower due to operating limitations and environmental factors.*

ENGINE:

8 HP* Tecumseh

Make	Tecumseh
Model	Snow King
Horsepower	8 @ 3600 rpm
Displacement	19.43 Cu. in (318.3 cc)
Oil Capacity	See Engine Owner's Manual

9 HP* Tecumseh

Make	Tecumseh
Model	Snow King
Horsepower	9 @ 3600 rpm
Displacement	19.43 Cu. in (318.3 cc)
Oil Capacity	See Engine Owner's Manual

10 HP* Briggs & Stratton

Make	Briggs & Stratton
Model	Intek Snow
Horsepower	10 @ 3600 rpm
Displacement	18.6 Cu. in (305 cc)
Oil Capacity	28 oz. (.84 L)

11 HP* Briggs & Stratton

Make	Briggs & Stratton
Model	Intek Snow
Horsepower	11 @ 3600 rpm
Displacement	18.6 Cu. in (305 cc)
Oil Capacity	28 oz. (.84 L)

11 HP* Tecumseh

Make	Tecumseh
Model	Snow King
Horsepower	11 @ 3600 rpm
Displacement	19.43 Cu. in (318.3 cc)
Oil Capacity	See Engine Owner's Manual

12 HP* Briggs & Stratton

Make	Briggs & Stratton
Model	Intek Snow
Horsepower	12 @ 3600 rpm
Displacement	18.6 Cu. in (305 cc)
Oil Capacity	28 oz. (.84 L)

13 HP* Briggs & Stratton

Make	Briggs & Stratton
Model	Intek Snow
Horsepower	13 @ 3600 rpm
Displacement	18.64 Cu. in (305 cc)
Oil Capacity	28 oz. (.84 L)

CHASSIS:

Wheels	- 860, 970, 1060, 1170	Tire Size: 16 x 4.8
	- 1180, 1280, 1390	Inflation Pressure: 20 psi (1,37 bar)
		Tire Size: 16 x 6.5
		Inflation Pressure: 20 psi (1,37 bar)
Spout Rotation		210 Depress
Impeller		12" (30cm) 4 Blade Ribbon Flighted Steel
Auger Opening Height		19" (47.5 cm)
Drive System		Friction Disc, 5 Forward Speeds, 2 Reverse

DIMENSIONS

Effective Clearing Width	
-860	24" (60cm)
-970	28" (70cm)
-1060	24" (60cm)
-1170	28" (70cm)
-1180	32" (80cm)
-1280	32" (80cm)
-1390	38" (97cm)

Length	
-860	57" (142cm)
-970	57" (142cm)
-1060	57" (142cm)
-1170	57" (142cm)
-1180	57" (142cm)
-1280	57" (142cm)
-1390	57" (142cm)

Height	
-860	38" (93cm)
-970	38" (93cm)
-1060	38" (93cm)
-1170	38" (93cm)
-1180	38" (93cm)
-1280	38" (93cm)
-1390	38" (93cm)

Weight	
-860	240 lbs (109kg)
-970	255 lbs (115kg)
-1060	245 lbs (111kg)
-1170	270 lbs (122kg)
-1180	265 lbs (120kg)
-1280	275 lbs (125kg)
-1390	300 lbs (136kg)

Parts & Accessories



REPLACEMENT PARTS

Replacement parts are available from your authorized dealer. Always use genuine Simplicity Service Parts.

MAINTENANCE ITEMS

Many convenient and helpful service and maintenance items are available from you authorized dealer. Some of these items include:

- | | |
|-------------------|--------------------|
| Engine Oil | Tire Sealant |
| Touch-Up Paint | Degrimer/Degreaser |
| Grease Gun Kit | Gas Stabilizer |
| 8 oz. Grease Tube | |

TECHNICAL MANUALS

Additional copies of this manual are available, as well as fully illustrated parts lists. These manuals show all of the product's components in exploded views (3D illustrations which show the relationship of parts and how they go together) as well as part numbers and quantities used. Important assembly notes and torque values are also included.

For applicable manuals currently available for your model, contact our Customer Publications Department at 262-284-8519. Have the information listed in the box below available when phoning in your request. Technical manuals can be downloaded from www.simplicitymfg.com

Model:	_____
Mfg. No.:	_____
Your Name:	_____
Address:	_____
City, State, Zip:	_____
Visa/Mastercard No.:	_____
Card Expiration Date:	_____