

Convection Oven-Broiler

USE AND CARE GUIDE
MODEL 7093S



READ AND SAVE THESE INSTRUCTIONS

WARNING: A risk of fire and electrical shock exists in all electrical appliances and may cause personal injury or death. Please follow all safety instructions.

IMPORTANT SAFEGUARDS

When using electrical appliances, basic safety precautions should always be followed, including the following:

- ◆ Read all instructions before using appliance.
- ◆ Do not touch hot surfaces. Use handles or dials and oven mitts.
- ◆ To protect against electrical shock do not immerse cord, plug, or appliance in water or other liquid. See cleaning instructions.
- ◆ This appliance is not for use by children.
- ◆ Close supervision is necessary when any appliance is used near children.
- ◆ Never leave appliance unattended when broiling.
- ◆ Do not clean with metal scouring pads. Pieces of the pad may break off and touch electrical parts, creating a risk of electric shock.
- ◆ Unplug from outlet when not in use and before cleaning. Allow to cool before attaching or removing parts and before cleaning the appliance.
- ◆ To disconnect, turn timer to OFF position then remove plug from wall outlet.
- ◆ Do not operate any damaged appliance. Do not operate with a damaged cord or plug, or after the appliance malfunctions or has been dropped or damaged in any manner. Contact Consumer Service for return authorization, examination, repair or adjustment.
- ◆ When using this appliance, provide at least four inches of space above, behind, and on both sides for air circulation.
- ◆ The use of attachments not recommended by Toastmaster Inc. may cause injuries.
- ◆ Do not use outdoors or while standing in a damp area.
- ◆ Do not let cord hang over edge of table or counter, or touch hot surfaces.
- ◆ Do not place on or near a hot gas or electric burner or in a heated oven.



- ◆ Extreme caution must be used when moving an appliance containing hot oil or other hot liquids.
- ◆ Use extreme caution when removing the bake/broil pan or disposing of hot grease.
- ◆ When broiling, the bake/broil pan and broil insert must be used.
- ◆ Do not use appliance for other than intended use.
- ◆ Do not store any item on top of the appliance.
- ◆ Do not use on surface where heat may cause a problem.

SAVE THESE INSTRUCTIONS

CAUTION: A short power supply cord is provided to reduce the risk of personal injury resulting from becoming entangled in or tripping over a longer cord. Extension cords are available from local hardware stores and may be used if care is exercised in their use. If an extension cord is required, special care and caution are necessary. Also the cord must be: (1) marked with an electrical rating of 125V and at least 13A, 1625W, and (2) the cord must be arranged so that it will not drape over the countertop or tabletop where it can be pulled on by children or tripped over accidentally.

POLARIZED PLUG: This appliance has a polarized plug, (one blade is wider than the other). As a safety feature to reduce the risk of electrical shock, this plug is intended to fit in a polarized outlet only one way. If the plug does not fit fully in the outlet, reverse the plug. If it still does not fit, contact a qualified electrician. Do not attempt to defeat this safety feature.

ELECTRIC POWER: If electric circuit is overloaded with other appliances, your oven may not operate properly. It should be operated on a separate electric circuit from other operating appliances.

This product is for household use only.

Getting To Know Your Convection Oven-Broiler

A convection oven circulates heated air continuously throughout the oven cavity to maintain uniform temperature around the food. This constant, gentle air flow is what seals in juices, promotes browning and shortens cooking time without turning and basting. Your Toastmaster® convection oven can bake, roast, broil, and dehydrate. The slow cook cycle cooks similar to a crock pot.

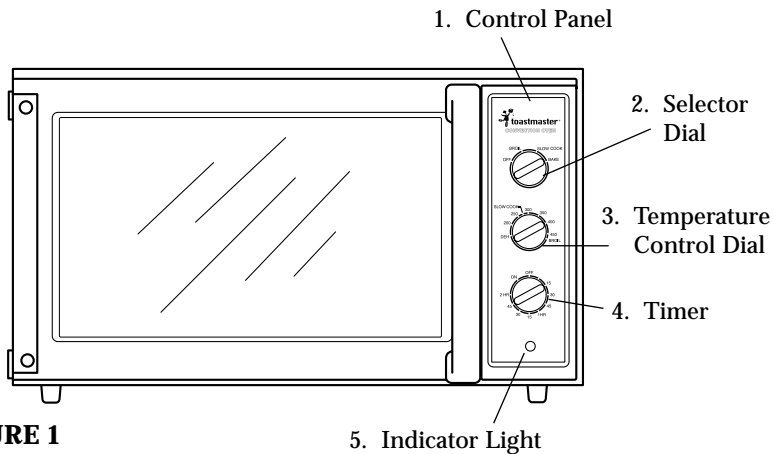

FIGURE 1

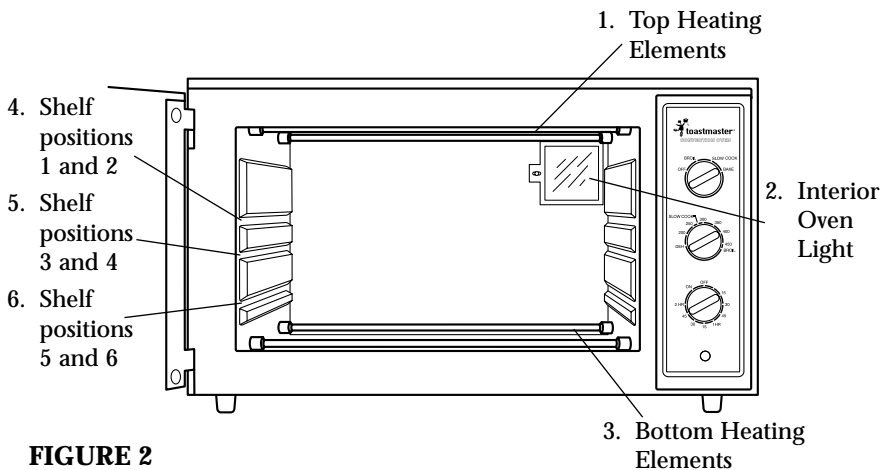

FIGURE 2

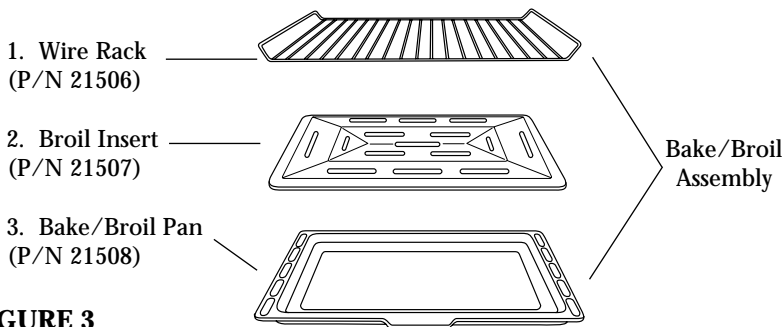

FIGURE 3

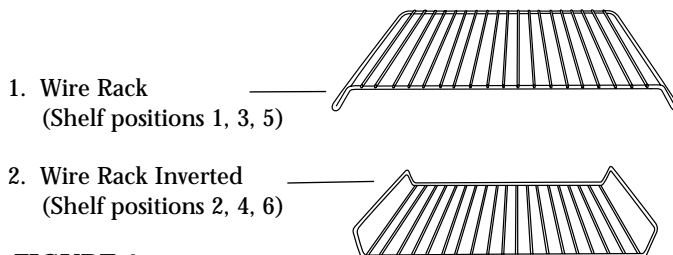

FIGURE 4

Selector Dial

The oven has three different settings: BAKE, SLOW COOK and BROIL. Turn dial to indicator line above dial to select setting. The convection fan is on in all modes.

Temperature Control Dial

Your oven has an adjustable temperature control dial with temperatures 200°-450° Fahrenheit. This allows you to prepare recipes according to package or recipe directions.

Timer

The timer control dial also acts as the oven's on and off switch. Turn the timer clockwise to select appropriate cooking time. The dial is marked with 1 or 2 hour (HR) in 15 minute segments. If cooking less than 1 hour, turn the timer past 1 hour, then back to desired cooking time. When cooking time is complete, a signal will sound and the unit will turn off automatically.

Manual On

If you are cooking for less than 15 minutes or do not wish to use the timer feature, turn the dial to MANUAL ON to turn oven on. Return to OFF position when cooking is complete. The indicator light will go off.

Indicator Light

Once the oven is preheated (10 minutes), the light will continue to turn on and off as the elements cycle indicating the oven is maintaining your preselected temperature.

NOTE: During SLOW COOK, the indicator light will remain on.

Heating Elements

On the SLOW COOK setting, constant low wattage heat is provided by the top and bottom elements. On the BAKE setting, the top and bottom elements will turn off and on as the thermostat cycles to control the cooking temperature. On the BROIL setting, only the upper elements cycle on and off. The indicator light will cycle on and off with the thermostat.

NOTE: Some elements will appear black during certain heating functions. This is normal.

Interior Oven Light

The light will be on anytime the unit is in operation. To replace oven light see page 9.

Rack Positions

The wire rack can be inserted into positions 1, 2, 3, 4, 5 or 6 (See Figure 4 for shelf positions). Baking on both the wire rack and bake/broil pan at the same time is not recommended except when using the SLOW COOK setting.



Bake

1. Place bake/broil pan or wire rack into correct position.
2. Plug into 120V ~ 60Hz outlet.
3. Position selector dial to BAKE. Turn temperature control dial to temperature setting. Set timer to MANUAL ON or desired baking time. Oven will shut off automatically if timer is set. Preheat if necessary. The indicator light will cycle off when the oven is preheated and continues to cycle during the baking cycle to maintain the selected temperature.

NOTE: When baking frozen dinners or foods with a leavening such as yeast, baking powder, soda or eggs, reduce temperature by 25°-50° to a minimum setting of 300°F. Baking time may not change.

4. Carefully center baking dish directly on bake/broil pan or wire rack and close door. You may place foods such as biscuits directly onto bake/broil pan.
5. Convection baking will cook some foods faster. Check 5-10 minutes before the end of the suggested bake time. Continue baking if necessary.
6. When finished, turn temperature control dial to lowest position. Make sure the timer is in the OFF position. The indicator light will go off.
7. Unplug and allow to cool completely before cleaning.

Roast

1. Remove bake/broil pan and wire rack.
2. Place bake/broil pan in position 5. The bake/broil pan must be placed below the food to prevent grease from coming in contact with heating elements and to reduce clean-up.
3. Put seasoned meat, fat side up, in center of wire rack. Insert wire rack in position 3. Do not cover.
4. Plug into 120V ~ 60Hz outlet.

5. Position selector dial to BAKE. Turn temperature control dial to 325°-350°F (standard roasting temperature). It is not necessary to preheat your oven. Since meats and poultry roast up to 25% faster in a convection oven, a meat thermometer should always be used to gauge internal temperature. The thermometer should be inserted into thickest portion of roast away from bones or fatty areas. Check progress two-thirds into the cooking process to ensure meat does not overcook.
6. Set timer to MANUAL ON or desired roasting time. Oven will shut off automatically if timer is set.
7. When finished, turn temperature control dial to lowest position. Make sure the timer is in the OFF position. The indicator light will go off.
8. Unplug and allow to cool completely before cleaning.

INTERNAL TEMPERATURE ROASTING CHART	
CUT	INTERNAL TEMPERATURE
Beef	145°F Rare 160°F Medium 170°F Well Done
Ham (fresh) Ham (precooked)	160°F 140°F Rare
Lamb	160°F Medium Well 170°F Well Done
Pork	160°F Medium 170°F Well Done
Turkey or Chicken, Whole	180°F
Turkey or Chicken, Breast	170°F



Hints For Roast

- ◆ A meat thermometer inserted into the center of the meat should always be used to ensure desired doneness.
- ◆ Roasting is recommended for large, tender cuts of meat and poultry. Seasoning prior to cooking adds to the flavor and the aroma during cooking.
- ◆ A layer of fat on the top of the roast promotes better browning and provides natural basting.
- ◆ When roasting meats with a high fat content, the bake/broil pan may fill with grease before cooking is completed. Carefully remove the bake/broil pan using oven mitts and empty. Replace for continued roasting.

Broil

1. Remove bake/broil pan and wire rack.
2. Place the broil insert in the bake/broil pan. Always use the bake/broil pan and broil insert when broiling. Place food on broil insert and position the bake/broil pan in the oven. Juices and fat will drip into the pan and decrease spattering while broiling. Close the door.
3. Plug into 120V ~ 60Hz outlet.
4. Position selector dial to BROIL. Turn temperature control dial to BROIL.
5. Since broiling time is usually brief, the use of a timer is not recommended. Set timer to MANUAL ON.
6. Broil food until done, turning half way through cooking time. Carefully remove bake/broil pan and broil insert from oven using oven mitts.
7. When finished, turn temperature control dial to lowest position. Make sure the timer is in the OFF position. The indicator light will go off.
8. Unplug and allow to cool completely before cleaning.

Hints For Broil

- ◆ Do not place aluminum foil on top of broil insert. This traps grease and can cause a fire.
- ◆ Trim excess fat from meat and score edges to prevent curling and thaw frozen meats before broiling. This will reduce smoke during broiling.

Slow Cook

1. Remove bake/broil pan from oven. Place wire rack in position 5. No preheat is necessary.
2. Cover baking container and place on wire rack in center of the oven.
3. Plug into 120V ~ 60Hz outlet.
4. Position selector dial to SLOW COOK. Turn temperature control dial to 250°F. The indicator light will remain on. Because of the low wattage being used, the heating elements will remain dark while maintaining the proper temperature.
5. Set timer to MANUAL ON.
6. Do not open the door during the first two hours of the slow cook period.
7. When finished, make sure the timer is in the OFF position. The indicator light will go off.
8. Unplug and allow to cool completely before cleaning.

Hints For Slow Cook

Most crock pot recipes may be used in slow cook by using the following guidelines.

- ◆ All baking dishes should be covered. Aluminum foil may be used if ends are tucked against edge of pan.
- ◆ Oven-proof glass and ceramic dishes are recommended. Aluminum foil pans and pans that will rust, such as cast iron or tin should not be used.



- ◆ Separate dishes can cook simultaneously, yet food retains its own flavor. Select foods that will take the same amount of time to cook.
- ◆ Milk, cream and sour cream may curdle. It is best to add them in the last hour of cooking. If a recipe specifies one of these ingredients as the only liquid in the cooking process, try substituting evaporated milk, water or condensed soup, such as cream of mushroom or chicken soup.
- ◆ Slow cook enhances the flavor of spices and salt. We recommend you reduce seasoning in your own recipes.
- ◆ Pre-cooked spaghetti and pasta products should be added in the last hour of slow cooking.

User Maintenance Instructions

This appliance requires little maintenance. It contains no user serviceable parts. Do not try to repair it yourself. Contact a qualified appliance repair technician if the product requires servicing.

Care And Cleaning

To assure optimum safety, keep unit clean, free of grease and food buildup.

CAUTION: Unplug appliance and allow to cool completely before cleaning. Never place unit, electric cord or plug in water or other liquids.

CAUTION: Do not clean oven with metal scouring pads. Pieces can break off and touch electrical parts, creating a risk of electric shock.

Clean-Up Of Bake/Broil Pan, Broil Insert And Wire Rack

1. Always unplug and allow to cool completely before cleaning or moving.
2. Remove bake/broil pan, broil insert and wire rack.
3. Clean with a mild or non-abrasive cleaner and a plastic scouring pad.
4. Rinse and dry thoroughly.

Clean-Up Of Non-Stick Walls And Interior

1. Always unplug and allow to cool completely before cleaning or moving.
2. Remove bake/broil pan and wire rack.
3. Clean interior after each use to avoid buildup.
4. Clean with a mild or non-abrasive cleaner and a plastic scouring pad. Do not rub too hard as surface can be scratched.
5. Rinse and dry thoroughly before closing door.

Clean-Up Of Oven Door And Exterior

The door can be removed for easier cleaning. To remove it, open fully and lift, clearing the hinge pins (See Figure 5). Do not put in dishwasher. To replace, slide the door over the hinge pins, being sure to gently push door all the way down on pins to avoid glass breakage.

1. Always unplug and allow to cool completely before cleaning or moving.
2. Clean with glass cleaner or mild detergent and damp cloth or plastic scouring pad. Do not use an abrasive cleaner or pad as they might mar the finish.
3. Rinse and dry thoroughly with a clean cloth. Allow to dry before closing door.



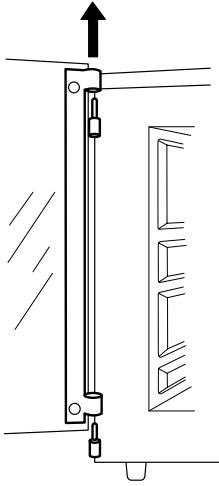

FIGURE 5

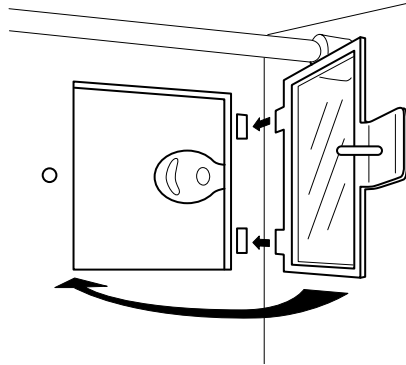

FIGURE 6

To Replace Oven Light

1. Unplug unit and allow oven to cool completely.
2. Remove screw from oven light bracket, holding onto bracket to prevent glass from falling.
3. Remove bracket and glass.
4. Remove bulb by turning counter-clockwise.
5. Replace with new bulb, turning clockwise.
6. Replace glass and bracket, being sure the two tabs on the bracket are in the slots provided for them on the oven wall.
7. Replace bracket screw.

**NOTE: Use only a 656 or equivalent 6-watt, 120 volt bulb.
Do not operate the oven without the oven lamp glass in place.**

LIMITED ONE YEAR WARRANTY

Warranty: This Toastmaster® product is warranted to be free from defects in materials or workmanship for a period of (1) year from the original purchase date. This product warranty covers only the original consumer purchaser of the product.

Warranty Coverage: This warranty is void if the product has been damaged by accident in shipment, unreasonable use, misuse, neglect, improper service, commercial use, repairs by unauthorized personnel, normal wear and tear, improper assembly, installation or maintenance abuse or other causes not arising out of defects in materials or workmanship. This warranty is effective only if the product is purchased and operated in the USA, and does not extend to any units which have been used in violation of written instructions furnished with the product or to units which have been altered or modified or to damage to products or parts thereof which have had the serial number removed, altered, defaced or rendered illegible.

Implied Warranties: ANY IMPLIED WARRANTIES WHICH THE PURCHASER MAY HAVE ARE LIMITED IN DURATION TO ONE (1) YEAR FROM THE DATE OF PURCHASE. Some states do not allow limitations on how long an implied warranty lasts, so the above limitation may not apply to you.

Warranty Performance: During the above one-year warranty period, a product with a defect will be either repaired or replaced with a reconditioned comparable model (at our option) when the product is returned to the Repair Center, or the purchase price refunded. The repaired or replacement product will be in warranty for the balance of the one-year warranty period and an additional one-month period. No charge will be made for such repair or replacement.

Service and Repair: Should the appliance malfunction, you should first call toll-free 1 (800) 947-3744 between the hours of 9:00 am and 5:00 pm Central Standard Time and ask for CONSUMER SERVICE stating that you are a consumer with a problem. Please refer to model number 7093S when you call.

In-Warranty Service (USA): For an appliance covered under the warranty period, no charge is made for service or postage. Call for return authorization (1 800 947-3744).

Out-of Warranty Service: A flat rate charge by model is made for out-of-warranty service. Include \$ 20.00 (U.S.) for return shipping and handling. We will notify you by mail of the amount of the charge for service and require you to pay in advance for the repair or replacement.

For Products Purchased in the USA, but Used in Canada: You may return the product insured, packaged with sufficient protection, and postage and insurance prepaid to the USA address listed below. Please note that all customs duty / brokerage fees, if any, must be paid by you and we will require you to pay the cost of customs duty / brokerage fees to us in advance of our performing any service.

Risk During Shipment: We cannot assume responsibility for loss or damage during incoming shipment. For your protection, carefully package the product for shipment and insure it with the carrier. Be sure to enclose the following items with your appliance: any accessories related to your problem, your full return address and daytime phone number, a note describing the problem you experienced, a copy of your sales receipt or other proof of purchase to determine warranty status. C.O.D. shipments cannot be accepted.

To return the appliance, ship to:

Attn: Repair Center
Toastmaster Inc.
708 South Missouri Street
Macon, MO 63552
Email: consumer_relations@toastmaster.com
www.toastmaster.com

To contact us, please write to or call:

Toastmaster Inc.
P.O. Box 6916
Columbia, MO 65205-6916
1 (800) 947-3744

Limitation of Remedies: No representative or person is authorized to assume for us any other liability in connection with the sale of our products. There shall be no claims for defects or failure of performance or product failure under any theory of tort, contract or commercial law including, but not limited to negligence, gross negligence, strict liability, breach of warranty and breach of contract. Repair, replacement or refund shall be the sole remedy of the purchaser under this warranty, and in no event shall we be liable for any incidental or consequential damages, losses or expenses. Some states do not allow the exclusion or limitation of incidental or consequential damages, so the above limitation or exclusion may not apply to you.

Legal Rights: This warranty gives you specific legal rights, and you may also have other rights which vary from state to state.



Keep Dated Sales Receipts for Warranty Service.

Keep this booklet. Record the following for reference:

Date purchased _____

Model number _____

Date code (stamped on bottom) _____

EVERYBODY EATS. It's a fact of life.

But sometimes preparing
meals can become a chore.

That's why TOASTMASTER has been invited
into millions of kitchens just like yours
so we can HELP YOU MASTER your
mixing, baking, grilling, toasting,
brewing, heating and serving
tasks WITH EASE AND STYLE.

The TOASTMASTER name stands for a
CELEBRATION of INNOVATION designed
to serve your life and keep you
COOKIN' IN STYLE.



toastmaster®

- **Cooking systems: bake, broil and slow cook**
- **2-hour timer**
- **Interior oven light**
- **Removable door for easy cleaning**
- **Accessories include wire rack, bake/broil pan and broil insert**



Questions

Call toll free 1-800-947-3744

Monday – Friday, 8:00 a.m. - 5:30 p.m. CST

www.toastmaster.com