



**U3-02A Mix Pump
Owner's/Service Manual**

Manual No. 513606 Rev. 0, April, 2004

INTRODUCTION

U3-02A MIX PUMP - OWNER'S / SERVICE MANUAL

This manual provides basic information about the mix pump and its components. Instructions and suggestions are given covering its basic operation and care.

The illustrations and specifications are not binding in detail. We reserve the right to make changes at any time without notice to mix pump or components without incurring any obligation to equip same on mix pump built prior to date of change.

DO NOT ATTEMPT to operate the mix pump until instructions and safety precautions in the manual are read completely and thoroughly understood. The mix pump should be operated only by qualified personnel. If problems develop or questions arise in connection with the installation, operation, or servicing of the mix pump, contact your local distributor or the company at the following location:

STOELTING, LLC
502 HWY. 67
KIEL, WISCONSIN 53042-1600

Ph: 920-894-2293

Fax: 920-894-7029

A Few Words About Safety

Safety Information

Read and understand the entire manual before operating or maintaining Stoelting equipment.

This Owner's Manual provides the operator with information for the safe operation and maintenance of Stoelting equipment. As with any machine, there are hazards associated with their operation. For this reason safety is emphasized throughout the manual. To highlight specific safety information, the following safety definitions are provided to assist the reader.

The purpose of safety symbols is to attract your attention to possible dangers. The safety symbols, and their explanations, deserve your careful attention and understanding. The safety warnings do not by themselves eliminate any danger. The instructions or warnings they give are not substitutes for proper accident prevention measures.

If you need to replace a part, use genuine Stoelting parts with the correct part number or an equivalent part. We strongly recommend that you do not use replacement parts of inferior quality.



Safety Alert Symbol:

This symbol Indicates danger, warning or caution. Attention is required in order to avoid serious personal injury. The message that follows the symbol contains important information about safety.

Signal Word:

Signal words are distinctive words used throughout this manual that alert the reader to the existence and relative degree of a hazard.



The signal word "WARNING" indicates a potentially hazardous situation, which, if not avoided, may result in death or serious injury and equipment/property damage.



The signal word "CAUTION" indicates a potentially hazardous situation, which, if not avoided, may result in minor or moderate injury and equipment/property damage.

CAUTION

The signal word "CAUTION" not preceded by the safety alert symbol indicates a potentially hazardous situation, which, if not avoided, may result in equipment/property damage.

NOTICE

The signal word "NOTICE" indicates information or procedures that relate directly or indirectly to the safety or personnel or equipment/property.

TABLE OF CONTENTS

SECTION 1 — INTRODUCTION	1
1.1 Description	1
1.2 Specifications	1
SECTION 2 — INSTALLATION INSTRUCTIONS	3
2.1 Shipment and Transit	3
2.2 National Sanitation Foundation Compliance Requirements	3
2.3 Installation	3
2.4 Mix Pump Check Out	5
SECTION 3 — OPERATION INSTRUCTIONS	7
3.1 Safety Precautions	7
3.2 Pump Motor Switch	7
3.3 Operation Of U3 Mix Pump	7
3.4 Cleaning	8
3.5 Disassembly and Inspection of Removable Parts	8
3.6 Sanitizing and Startup	9
3.7 Cleaning Mix Lines	10
SECTION 4 — MAINTENANCE INSTRUCTIONS	11
4.1 Overrun Adjustment	11
4.2 Preventative Maintenance	11
SECTION 5 — TROUBLESHOOTING	13
SECTION 6 — REPLACEMENT PARTS INFORMATION	15
6.1 How to Order Replacement Parts	15
6.2 Parts List and Reference Drawings	15
WARRANTY	23

LIST OF ILLUSTRATIONS

Figure	Description	Page
1	U3-02A Pump	1
2	Mix Transfer Line	3
A	Mix Pump Hose	4
B	Pickup Hose	4
C	Pickup Hose	4
3	Mix Pump Installation	5
D	3-way Tee Connection	5
4	Pump Motor Switch	7
5	Mix Pump Operation	8
6	Removing Parts	8
7	Overrun Adjustment	11
8	Reposition Mix Pump Hose	12
9	Pump Roller Assembly	12
10	Pump and Decal Assembly	15
	Exploded Parts Illustrations	17-21
	Wiring Diagram	22

SECTION 1 INTRODUCTION

1.1 DESCRIPTION

The Model U3-02A Remote Mix Pump is specially designed for use with Stoelting remote pressurized freezers. Used with large capacity mix containers located in your bulk storage cooler, the U3-02A Pump keeps mix handling to a minimum.

Stoelting's Model U3-02A Remote Mix Pump performs three important functions with precision and reliability. First, it transfers a continuous supply of mix from your remote storage container to the freezing cylinder of your freezer, quickly and conveniently. Second, the U3-02A Pump precisely injects a preset amount of air into the mix, maintaining overrun to assure maximum profitability. Third, it pressurizes the freezing cylinder, forcing frozen product through the spigot at the rapid dispense rates needed by high volume locations.

1.2 SPECIFICATIONS

WEIGHT

24 lbs. (10.89 kg)

DIMENSIONS

Width: 9-3/4" (24.8 cm)

Height: 8-1/2" (21.6 cm)

Depth: 10-1/8" (25.7 cm)

ELECTRICAL

1 phase, 115 volts. Approximately 1.6 total running amps. Cord and plug attached.

WARRANTY

One year parts.

UL, C-UL Approved, NSF Approved



Figure 1
U3-02A Pump

SECTION 2 INSTALLATION INSTRUCTIONS

2.1 SHIPMENT AND TRANSIT

The mix pump has been completely assembled, operated and inspected at the factory. Upon arrival at the final destination, the mix pump must be checked for any damage that may have occurred during transit.

The mix pump should arrive in satisfactory condition. **THE CARRIER IS RESPONSIBLE FOR ALL DAMAGE IN TRANSIT, WHETHER VISIBLE OR CONCEALED.** Do not pay the freight bill until you have checked the equipment. Have the carrier note any visible damage on the freight bill. If concealed damage and/or shortage is found later, advise the carrier inspector within 10 days and request inspection. The customer must place claim for damages and/or shortages in shipment with the carrier. **Stoelting, LLC cannot make any claims against the carrier.**

2.2 NATIONAL SANITATION FOUNDATION COMPLIANCE REQUIREMENTS

In order to comply with "NSF International" (NSF) code #6:

- A. This unit (remote pump) must be installed with a "NSF" listed refrigerated mix transfer line. The mix transfer line must be pitched to cooler, with no sags or low points, to allow complete drainage (Fig. 2).
- B. The product at the mix pump and in transfer lines must be maintained below 41°F (5°C.)

2.3 INSTALLATION

A. Follow the steps below to install the mix pump in an upright position on the wall using optional pump mounting kit. Allow clearance for a mix container under pump. See Figure 2.

1. Mount by locating four (4) hole centers on cooler wall using mounting bracket as template.



WARNING

Risk of Personal Injury/property Damage

Verify electrical and refrigeration line location inside and behind the cooler's walls before drilling.

2. Drill four (4) 1/2 inch diameter holes into cooler wall 3/4 inch deep. See Figure 3.
3. Insert well-nut to flange and apply silicone sealant around outside diameter of flange and cooler wall.
4. Repeat steps 2 & 3 for other located hole centers.
5. Mount bracket to cooler wall with supplied wing screws. Hand tighten until secure.
6. Thread plastic standoffs (small parts bag) onto all three pump mounting studs located under the pump until bottomed.
7. Mount pump to bracket with wing nuts. Pump will be held above the bracket by the standoffs.

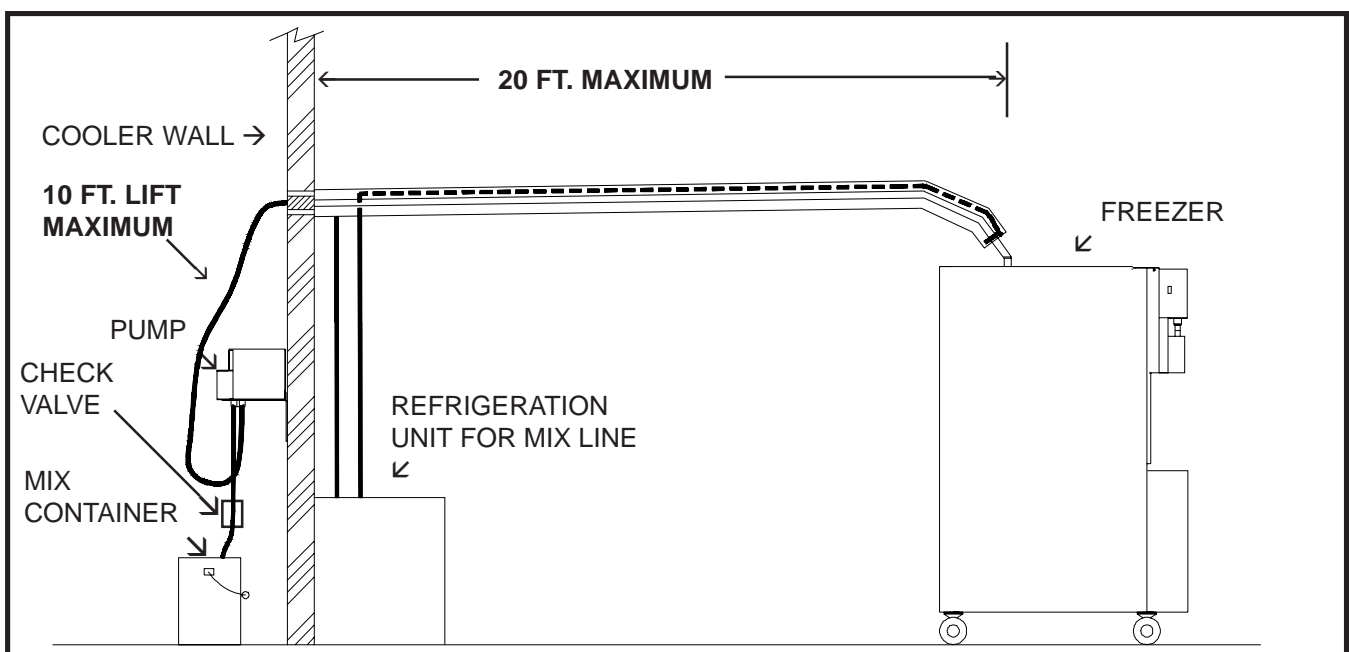

**Figure 2
Mix Transfer Line**

B. Mix Pump Hose Installation.

Follow the steps below to install the mix pump hose.

1. Turn pump on.
2. Feed one end of mix pump hose into the entering or pick-up hose side (left) of black cover.
3. Gently push the hose into the black cover until it begins to feed. See Figure A.

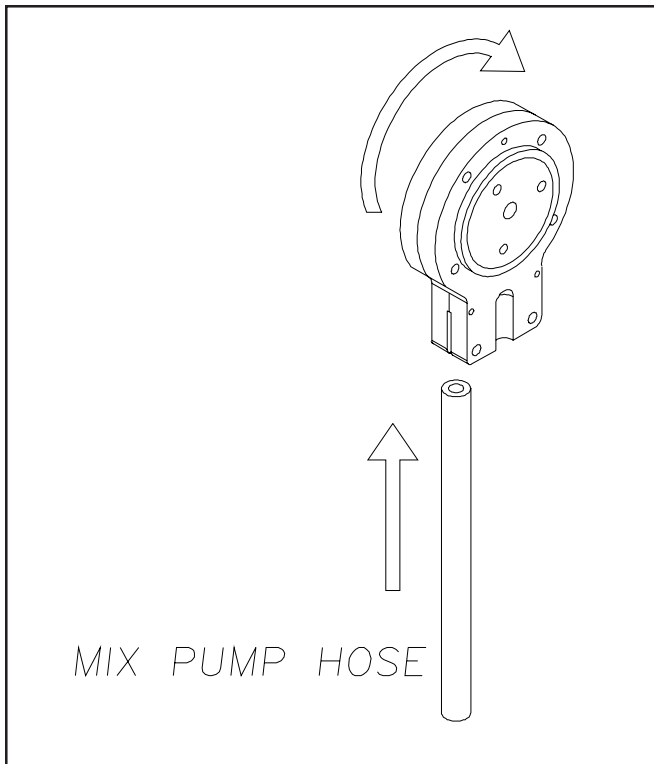

Figure A

4. Allow the hose to feed itself thru the pump until 6" remains on the entering side.
5. Turn pump off.
6. Connect mix pump hose to pickup hose adapter using small hose clamp. See Figure B.

CAUTION

Risk of Product Damage

Avoid twisting mix pump hose while feeding into cover. Twisting the hose may cause the hose to rupture.

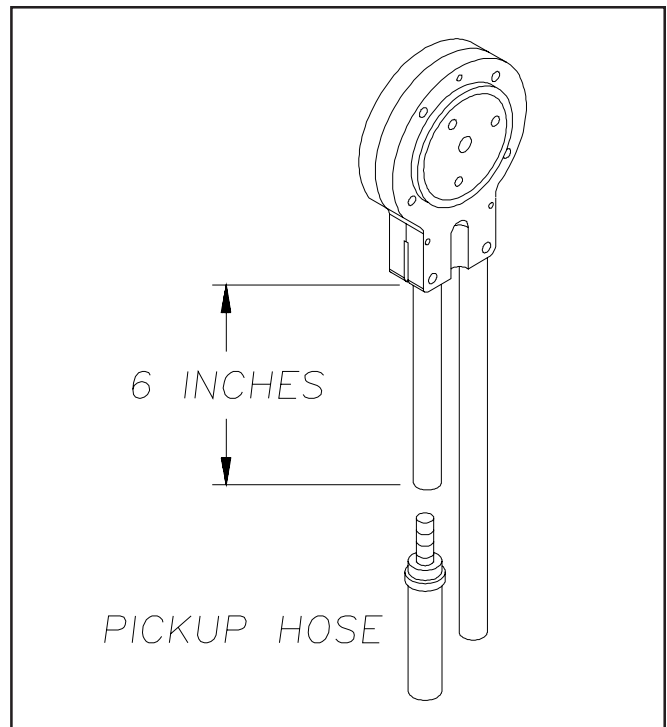

Figure B

7. Turn pump on.
8. Gently pull on the discharge hose to help remaining 6" of mix pump hose to feed thru pump until hose adapter prevents further feeding.
9. Turn pump off. See Figure C.

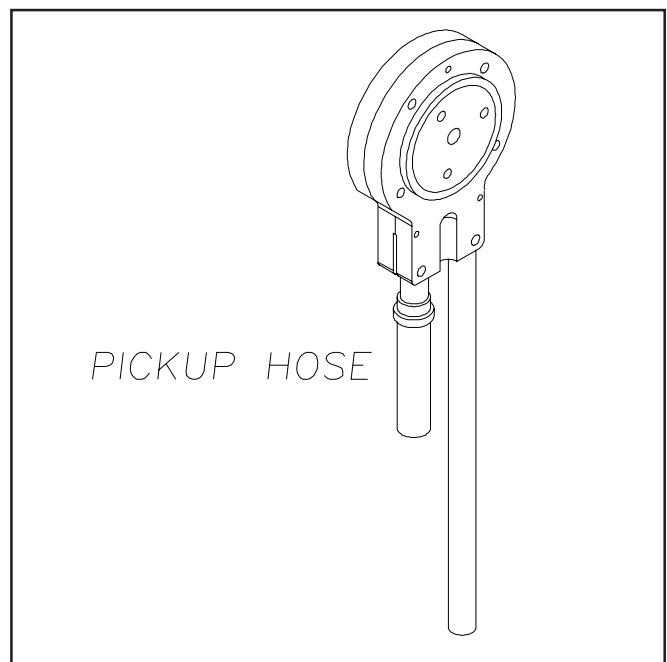
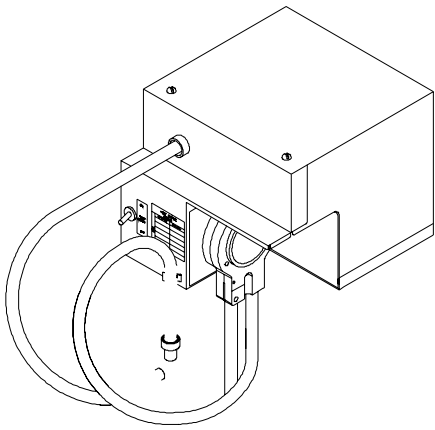

Figure C



SECTION 3 OPERATION INSTRUCTIONS

3.1 SAFETY PRECAUTIONS

Do not attempt to operate the U3-02A pump until the safety precautions and operating instructions in the manual are read completely and thoroughly understood.

Take notice of all warning labels on the U3-02A pump. The labels have been put there to help in maintaining a safe working environment. The labels are designed to withstand washing and cleaning. All labels must remain legible for the life of the mix pump. Warning labels should be checked periodically to be sure they have not been removed, painted over, rubbed off, and can be recognized as warning labels.

If replacement labels are needed, indicate the part number, type of label, location of label, and quantity required. Mail your name and address to:

STOELTING, LLC
ATTENTION: Customer Service
502 Hwy 67
Kiel, Wisconsin 53042

Labels will be furnished and mailed at no charge.

SAFE OPERATION IS NO ACCIDENT; Observe these rules:

- A. Know the U3-02A pump - read and understand the Owner's Manual.
- B. Wear proper clothing - avoid loose fitting garments, and remove watches, rings or jewelry which could cause a serious accident.
- C. Maintain a clean work area - avoid tripping or slipping by cleaning up the area and keeping it clean.
- D. Stay alert at all times - know which switch, push button or control you are about to use and what effect it is going to have.
- E. Turn all switches to OFF prior to making any adjustments.
- F. Do not attempt to repair or perform maintenance on the mix pump until the main electrical power has been disconnected.
- G. Do not operate the mix pump if unusual or excessive noise or vibration occurs.

3.2 PUMP MOTOR SWITCH

The PUMP MOTOR switch (Fig. 4) is located on the mix pump assembly. When the pump motor switch is placed in the ON position, the mix pump motor will be actuated to pump mix into the freezer cylinder. When the set pressure is reached, the mix pump will shut off automatically. When the pump motor switch is placed in the OFF position, the mix pump will be inoperative.

NOTE

The mix pump motor is equipped with an internal overload that will "trip", disabling the pump when the motor is overloaded. Consult the trouble shooting section for corrective information. The internal overload will automatically reset after cooling. If the condition continues, contact a qualified service person.

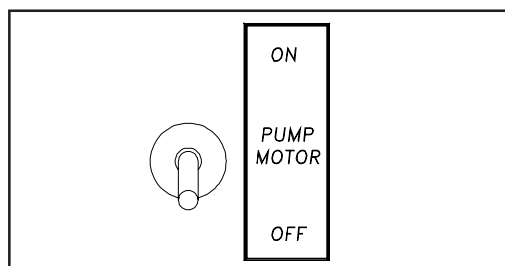

Figure 4
Pump Motor Switch

3.3 OPERATION OF U3 MIX PUMP

This section describes the operation of the U3 mix pump.

CAUTION

Risk of Product Damage

Mix pump hose must be repositioned every 1 -2 weeks. Failure to comply will result in reduced mix pump liquid capacity, dispense stoppage, popping, and possible mix pump hose leakage. Hose leakage may damage the pump roller assembly and void the factory warranty.

- A. Refer to freezer owners manual for the operation of the freezer.
- B. Mix Operation: The peristaltic mix pump contains one continuous mix pump hose. When looking at the face of the peristaltic mix pump, the left side of this hose is the suction or pickup. The right side of the hose is the discharge. Mix is drawn up the suction side of the hose and transferred thru the discharge side to the freezer (Fig. 5).
- C. Air Operation: The air compressor operates concurrently with the peristaltic mix pump. Air enters thru an intake check valve on the piston downstroke. The air is discharged thru an output check valve, and second check valve on the piston upstroke. The air and mix join at the tee and then travel to the freezer.

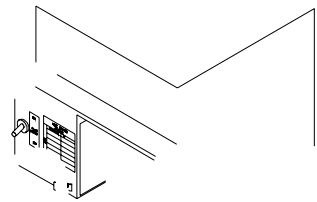
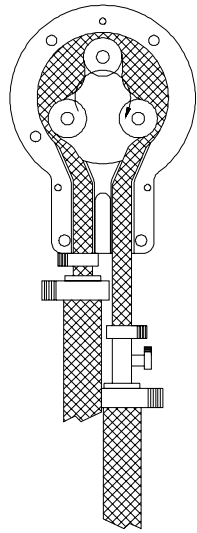



CAUTION

System Under Pressure

Never disconnect hoses from freezer or pump without first opening spigot to relieve pressure.

NOTE

If the mix lines or air line is difficult to remove, soften with a rag soaked in hot water. Hose connections may be sprayed with Haynes Sanitary Lubricant for ease of removal. Do not loosen or remove the mix pump cover wingnuts. Maintain the mix pump hose in its operational condition.

1. Loosen clamp and remove air hose from pump compressor.
2. Loosen clamp and disconnect mix pump hose. Remove the pickup hose, mix check valve and pickup hose adapter (and bag adapter if applicable) as an assembly from mix container.
3. Completely disassemble both hose assemblies and check valve. Place hoses, tee, check valve assembly, and pickup hose adapter in mild detergent water and wash thoroughly. Use soft bristle brushes to clean inside of fittings. Rinse all parts in clean 120°F water.
4. Carefully inspect each part for wear or damage. Replace worn or damaged parts.
5. Prepare two gallons (7.5 liters) of sanitizing solution using a USDA certified grade sanitizing solution. Sanitize all removed parts, then air dry.
6. Check Hose Service Record decal to determine if hose reposition or replacement is required at this time (Sec. 4.2).
7. Reassemble both hose assemblies per the diagram (Fig.6). Reconnect assemblies to the pump and discharge hose per the diagram, using the clamps.

CAUTION

Risk of Product Damage

Do not use excessive force when assembling parts. Parts fit together easily when properly installed.

3.6 SANITIZING AND STARTUP

For sanitizing to be effective, it must be performed after the mix pump and freezer parts have been cleaned, and just prior to filling the freezer with mix. Sanitizing the night before is not effective.

To sanitize, refer to local sanitary regulations for applicable codes and recommended disinfecting products and procedures. The frequency of cleaning must comply with local health regulations. Use a solution containing 100 PPM of free available chlorine. Use "Stera-Sheen Green Label Sanitizer and Cleaner," or others in accordance with Health Inspection Requirements.

NOTE

Stoelting, LLC has found that STERA-SHEEN GREEN LABEL SANITIZER AND CLEANER does an effective job of properly sanitizing and cleaning a pump and soft serve freezer. We therefore include a sample with each new freezer. For further information read the directions on the packet. Other products may be as effective.

CAUTION

Risk of Product Damage

Avoid prolonged contact of sanitizer with freezer. Prolonged contact may cause corrosion of stainless steel parts and void factory warranty.

In general, sanitizing may be conducted as follows:

1. Prepare two gallons (7.5 liters) of sanitizing solution following manufacturer's instruction, and place pump suction (inlet) line into solution.
2. Place mix pump switch in ON position.
3. Check for leaks when freezer barrel is first pressurized with sanitizing solution.
4. Place freezer CLEAN-OFF-ON switch in CLEAN mode (no refrigeration).
5. After five minutes in CLEAN mode, open spigot and pump the remaining sanitizing solution thru the freezer, close spigot and switch the freezer and pump to OFF.
6. Place pickup tube into mix bag or container of mix and start the pump.
7. Open spigot, allowing incoming mix to push remaining sanitizer out of hoses and freezing cylinder. Close spigot as soon as pure mix begins to come out (after about one pint).
8. Push in the air bleed valve located on the front door (Challenger Series) and allow the mix to come within 1/2" of the air bleed valve, then close the valve.
9. Place freezer in the on or freezing position.

3.7 CLEANING MIX LINES

The mix lines must be cleaned and sanitized whenever changing mix or whenever the freezer is off for an extended period of time - such as overnight, or nonbusiness days. The mix lines are sufficiently cleaned and sanitized when cleaning and sanitizing the pump and freezer as an assembly.

Once every 2 weeks, if required, perform the following steps:

- A. Mix 2 gallons (7.5 liters) of milkstone remove solution according to the directions on the container and pump through the mix line.
- B. Cut a piece of sponge slightly larger than the inside diameter of the mix line. Place the sponge inside the mix line and force through with tap water pressure. A garden hose repair end clamped to the mix line works well for this purpose.

SECTION 4 MAINTENANCE INSTRUCTIONS

4.1 OVERRUN ADJUSTMENT

The product when served is a combination of air and mix. Overrun is a measure of the amount of air blended into the mix.

Overrun can be expressed in terms of the amount of weight loss for a given volume. For example, if a pint of liquid mix weighs 18 ounces and a pint of frozen product with air added weighs 12 ounces, the over-run is said to be 50 percent ($18 \text{ oz.} - 12 \text{ oz.} = 6 \text{ oz.}$, $(6 / 12) \times 100 = 50\%$).

The overrun can be checked by placing a one pint container on an ice cream scale and zeroing out the scale. Then fill a one pint container with frozen product. The container should be filled over the top and leveled with a straightedge. The product should not contain any air pockets. When weighed on an ice cream scale, one pint of product should weigh 12 to 13 ounces.

The mix pump has been preset at the factory to produce a product with approximately 40% overrun. Because of differences in mix formulation, temperatures and barometric pressure, this figure may vary. It will be necessary for approximately 2 gallons of mix to be pumped thru the freezer before changes in the product are noticeable due to adjustments in overrun.

Overrun is controlled by the length of the air compressor piston stroke within the piston cylinder. Lengthening the stroke within the cylinder will increase overrun. Conversely, shortening the stroke will decrease overrun. To perform an overrun adjustment, refer to the following procedure:

- A. Turn the mix pump switch to the OFF position and unplug the mix pump from its grounded 115V receptacle.
- B. Remove the 2 electrical box cover screws and remove the electrical box cover.
- C. On air compressor side of pump, locate the long/slender piston rocking arm. The rocking arm downward travel is limited by a stationery cam. On the face of the cam there is an overrun setting indicator plate numbered 3 thru 8 and an adjustment knob (Fig. 7).
- D. The overrun setting is indicated by a pointed pin.
- E. To adjust overrun, loosen the allenhead screw (located within the center of the adjustment knob) with the 5/32" allen wrench provided. Rotate the adjustment knob counterclockwise to a higher number for higher overrun, or clockwise to a lower number for lower overrun. Each number multiplied by 10 represents the overrun percentage (ie: #4 = 40% overrun).

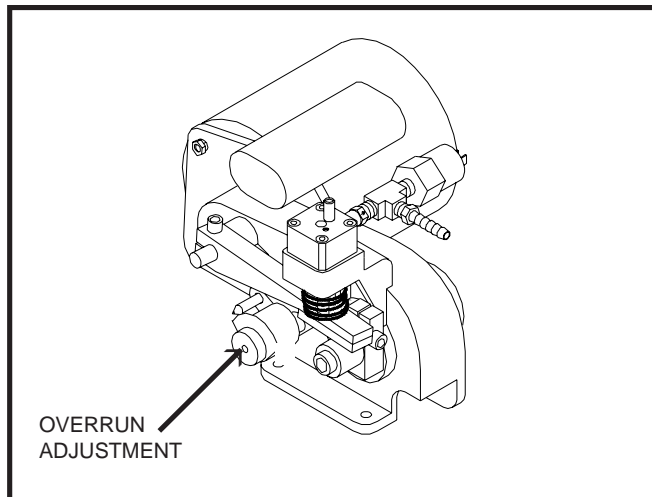

Figure 7
Overrun Adjustment

- F. Tighten the allen screw, then place the wrench back in its clip. Replace the electrical box cover and screws, plug the mix pump into its grounded 115V receptacle and turn the mix pump power switch to the ON position.

4.2 PREVENTATIVE MAINTENANCE

To assure trouble free operation and consistent overrun when using the U3 mix pump, we must follow mix hose repositioning and replacement procedures. The following is the preventative maintenance schedule:

- A. MIX PUMP HOSE REPOSITION (every one or two weeks.)

NOTE

Mix pump hose must be repositioned every 1 - 2 weeks. Failure to comply will result in reduced mix pump liquid capacity, dispense stoppage, popping, and possible mix pump hose leakage.

1. Run cleaning solution through pump.
2. Turn pump off and if connected to freezer, relieve any pressure by opening the spigot.
3. Grasp the pick-up hose end of the mix pump hose with one hand and turn the pump on. Pull down on the pick-up hose end until 12 to 14 inches of tubing has reversed fed through the pump, then turn the pump off.
4. Loosen small clamp at the pick-up hose adapter and disconnect mix pump hose.
5. Cut 7-1/2 inches off the end of the mix pump hose. The height of the pump can be used to measure. See Figure 8.

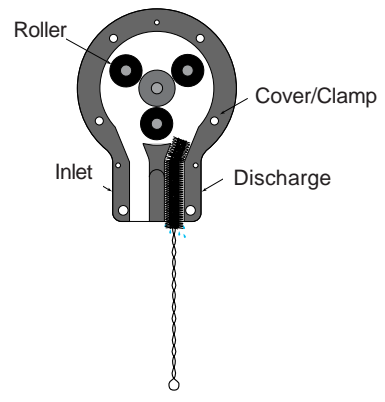

SECTION 5 TROUBLESHOOTING

1. PUMP MOTOR DOES NOT RUN

Power to pump is off.	Supply power to pump.
Low voltage.	Check for low voltage.
Mix pump hose jammed inside black cover/clamp.	Disconnect pump from power source. Remove four cover/clamp thumb screws. Separate cover/clamp halves and remove outer half. Remove jammed hose. Re-install cover/clamp and tighten four thumb screws securely. Allow motor thermal overload to reset. See Sec. 4.2 for hose replacement. Do not use jammed portion of hose.
Pump motor overloaded.	Allow internal thermal overload to reset; determine overload cause and repair.
Pressure switch on pump is defective.	Check mechanical operation and continuity of pressure switch.
Defective motor/capacitor	Check motor amperage draw and/or capacitor. Replace motor or capacitor.
Defective toggle switch.	Check continuity; repair or replace.

2. PUMP OPERATES BUT CYLINDER WILL NOT FILL

NOTE 1: A PROPERLY WORKING PUMP WILL FILL AN 8 OZ. CUP WITH MIX IN ABOUT 9 SECONDS.

NOTE 2: IMMEDIATELY AFTER A "BAG CHANGE" THE PUMP MAY BE UNABLE TO RE-ESTABLISH IT'S PRIME WITH THE SYSTEM AT OPERATING PRESSURE. IN THIS CASE, TURN THE PUMP OFF. DRAW 2-3 PINTS TO REDUCE SYSTEM PRESSURE TO ZERO. TURN PUMP ON. PURGE REMAINING AIR IN MIX BAG AND PICK-UP HOSE.

IMPORTANT: Before connecting the pick-up hose to the mix bag, purge the mix bag of air to the extent possible.

Out of Mix.	Replenish mix supply.
Mix pump hose kinked inside black cover/clamp.	Follow mix pump hose jammed repair. (See #1 above.)
Hoses assembled incorrectly.	Refer to diagram for correct hose connections.
Mix pump hose service life is exceeded.	Reposition/replace mix pump hose. See Sec. 4.2.
Mix pump hose not connected to freezer.	Connect mix pump hose to freezer.
Ice crystals in mix.	Completely thaw mix prior to use.
Mix bag drawn against adapter.	Assure bag is clear of pick-up tube.
Foreign objects in mix.	Clear blockage. Use fresh mix.
Check valve is backwards.	Observe flow arrow for proper orientation.

3. OVERRUN TOO LOW OR NO OVERRUN

Overrun setting too low.	Increase overrun setting.
Air leak.	Tighten all hose clamps.
Air compressor not pumping air.	Contact local Stoelting Distributor.

4. OVERRUN TOO HIGH

Mix pump hose service life is exceeded.	Reposition/replace mix pump hose.
Out of mix.	Replenish mix supply.
Overrun setting too high.	Decrease overrun setting.
Pick-up leg of mix pump hose is collapsing.	See Section 4.2.

NOTE: ALSO SEE "2" ABOVE.

5. REPLACEMENT MIX PUMP HOSE WON'T FEED THROUGH PUMP	
Feeding hose into discharge hole of mix pump cover.	Feed hose into pick-up side of cover.
Hose ends not cut squarely.	Carefully cut hose end off squarely (no tails).
Force feeding too quickly.	Gently and slowly assist feeding of hose up into pick-up hose side of cover.
Pump motor not running.	Turn on motor switch. Also see Item 1 above.
6. AIR EXITING MIX PICK-UP HOSE	
Pickup tube check valve missing.	Contact local Stoelting Distributor.
7. DISPENSED PRODUCT AIR "POPS"	
Overrun setting too high.	Reposition/replace mix pump hose.
Mix pump hose service life is exceeded.	Reposition/replace mix pump hose.
Overdrawing the freezer's capacity.	Reduce dispense rate.
Recent "mix-out" condition.	Open spigot fully and allow excess air to "belch" out.
NOTE: ALSO SEE 2 & 4 ABOVE.	
8. MIX LEAKAGE FROM PUMP	
<i>CAUTION: To prevent mix pump damage from dried mix deposits, immediately disassemble and clean pump.</i>	
Mix pump hose service life is exceeded.	Remove mix pump hose. Disconnect pump from power source. Remove mix pump cover/clamp. THOROUGHLY rinse three squeeze rollers using a spray bottle filled with hot water. Thoroughly clean all mix from pump. See Sec. 4.2 for hose replacement. Lubricate squeeze roller bearings, see Item #10 below.
9. PUMP HAS POOR CAPACITY	
Lift and run limits are exceeded.	Pump is limited to 10' lift, 20' run.
NOTE: Also see 2, 4, 6 & 7.	
10. MIX IN AIR HOSE	
Air/mix tee above black cover/clamp.	Air/mix tee must be below black cover/clamp.
Air leak.	Tighten all hose clamps.
Mix hose on wrong air/mix tee fitting.	Refer to diagram for correct hose connections.

SECTION 6 REPLACEMENT PARTS INFORMATION

6.1 HOW TO ORDER REPLACEMENT PARTS

To assure the receipt of the proper replacement parts, supply your dealer, distributor or the company with the following information:

- A. Model number of equipment.
- B. Serial number of Model. (Stamped on nameplate).

C. Part number, part name, and quantity needed. Many part names and numbers are listed in this manual.

NOTE

Minimum Billing is \$50.00 Net.

6.2 PARTS LIST AND REFERENCE DRAWINGS

The following lists and drawings will aid the user when ordering parts or servicing the mix pump.

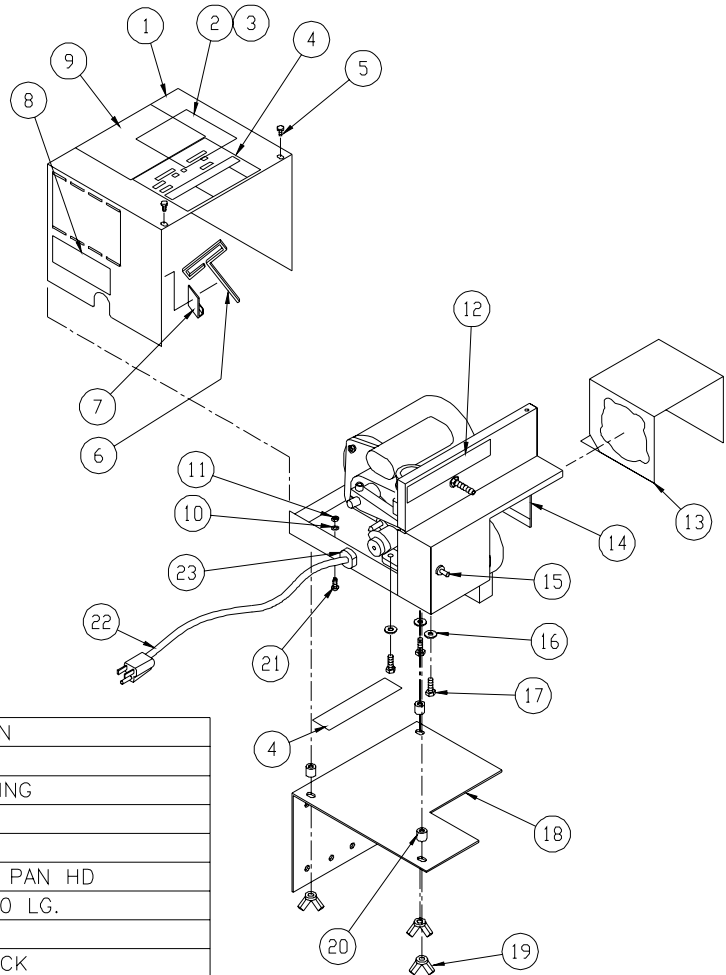

ITEM	STOELTING PN	QTY	DESCRIPTION
1	4177692	1	PUMP BOX COVER
2	130000	1	BAG, ENVELOPE FRONT LOADING
3	1995611	1	WIRING DIAGRAM, U3 PUMP
4	2171853-01	1	MODEL ID PLATE
5	647512	2	SCREW MACH 8-32 X 3/8 PAN HD
6	778027	1	WRENCH, ALLEN 5/32 X 3.0 LG.
7	266018	1	CLIP ADHESIVE BACKED "J"
8	324105	1	DECAL CAUTION-ELECT SHOCK
9	324509	1	DECAL CLEANING (SS & SHAKE)

13	3171850	1	SPLASH GUARDD
14	4183116	1	PUMP BOX
15	718532	1	SWITCH TOGGLE 10AMP 250V
16	766066	3	W

18	3170824	1	MOUNTING BRACKET
----	---------	---	------------------

**Figure 10
Pump and Decal Assembly**

ITEM	STOELTING PN	QTY	DESCRIPTION
1	264235	4	CLAMP HOSE 3-8/9-16 MIN/MAX D
2	324150	1	PUMP ON OFF DECAL
3	756067	13"	TUBING .25 ID
4	376041	1	FITTING, 1/4, 1/2, 1/4 S'STL BARBED
5	324659	1	HOSE SERVICE DECAL
6	266041		
7	723553	1	INSTRUCTION TAG, CAUTION
8	739040	1	CABLE TIE

12	375867	1	FITTING UNION 1/4"x1/2" BARBED
13	264241	3	CLAMP HOSE 9/16 TO 13/16 STEEL

15	1172864	1	VALVE BODY-OUTER
16	694247	1	SPRING COMP 13/16x3/8x3/4
17	696130	1	LOCK CLIP FOR VALVE
18	762256	1	VALVE OUTLET CHECK (MOLDED)
19	1151965	1	VALVE BODY-INNER
20	624607	2	O-RING 11/16x7/8

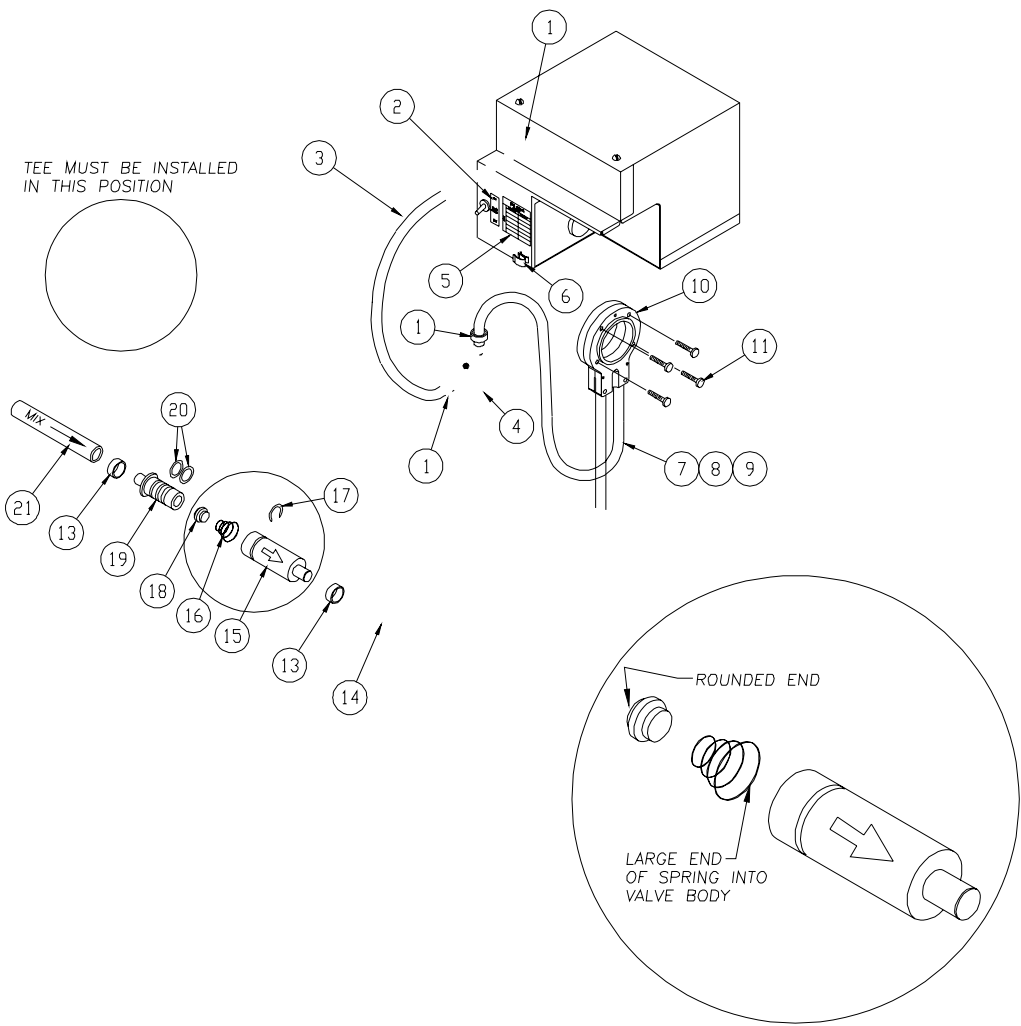

ITEM	STOELTING PN	QTY	DESCRIPTION
1	644065	1	SCREW 1/4-20 X 3/4, S'STL
2	538306	4	NUT 10-32UNF S'STL
3	1177681	1	ROCKER ARM & PAD
4	M002841	AS REQ	TAPE TEFLON THD SEAL
5	432003	1	VALVE HEAD
6	1171859	1	O-RING
7	1171860	1	VALVE SPRING
8	1171861	1	NEEDLE VALVE
9	1171862	1	SCREW 8-32 X 1/2
10	1171863	1	VALVE GUIDE
11	1171864	1	O-RING
12	762246	1	VALVE, CHECK, 1/3 S'STL
13	1171866	5	SCREW 10-32 X 1-1/4
14	1171867	1	O-RING
15	1171868	1	REED VALVE
16	1171958	1	AIR FILTER
17	1171870	1	CYLINDER SLEEVE
18	1171871	1	PISTON SPRING
19	1171872	1	SPRING SEAT
20	1171873	1	PISTON
21	1171874	1	BALL BEARING
22	652412	1	SCREW SHOULDER 3/8 X 3/4 S'STL
23	1171994	1	SLEEVE BEARING
24	1171977	1	ROLLER
25	1171978	1	SCREW 1/4-28 X 3/4
26	1171979	1	CRANK ARM
27	1171980	1	PULLEY LARGE - ALUMINUM
28	1171981	1	ECCENTRIC
29	692226	1	SPACER, ROLLER HOUSING
30	1171982	1	KNOB
31	1171983	1	DIAL
32	1171984	1	POINTER
33	1171985	1	DOWEL PIN 3/8 X 2.5LG
34	1171986	2	FLANGE BEARING
35	1171987	1	WICK
36	1171988	1	COLLAR
37	1171989	1	PULLEY SMALL - ALUMINUM
38	1171990	1	BELT
39	453010	3	HOUSING, ROLLER
40	1171991	2	BALL BEARING
41	580048	1	PLATE, ROLLER HOUSING, CENTER
42	580047	1	PLATE, ROLLER HOUSING, END
43	538296	3	NUT HEX #10-24 X 3/8 SS
44	146023	6	BALLBEARING, .250 BORE, DBL SEALED
45	625392	6	RETAINING RING, .250 EXT.
46	674152	3	SHAFT, ROLLER
47	674151	1	SHAFT, ROLLER CARRIER
48	522229	1	MOTOR 115-230/60/1
49	766058	4	LOCK WASHER #10
50	3171952	1	COVER/CLAMP
51	667896	1	BUMPER SEAL
52	246063	1	PUMP BODY CASTING
53	653042	4	SCREW THUMB 10-24NC
54	1171955	1	SET SCREW 10-32
55	1177036	1	WASHER 1/4"
56	1177037	1	SCREW 4-40 X 1.00
57	1177034	1	AIR FILTER RETAINER TOP
58	1177035	1	AIR FILTER RETAINER BOTTOM
59	1177033	1	BUMPER RING
60	1171959	1	O-RING
61	1171956	1	WASHER NYLON
62	M830011	AS REQ	GREASE, MULTIPURPOSE
63	M840073	AS REQ	MOTOR OIL 10W
64	M820172	AS REQ	ADHESIVE LOCTITE 242-31
65	766430	1	WASHER ROUND
66	732307	1	TERMINAL QUICK CONNECT FEMALE
67	732112	1	TERMINAL QUICK CONNECT MALE
68	650146	2	SCREW SSS 8-32 X 3/16 CUP PT
69	732133	1	WHITE CRIMP TERMINAL
70	1177767	1	DECAL, ROLLER HOUSING
71	M820097	1	ADHESIVE LOCTITE #609
72	1177915	1	SPACER
73	M820210	AS REQ	LUBRICANT NEVER SEEZE
74	376035	1	FITTING, TEE, BRASS 1/8-27 NPT
75	717928	1	SWITCH, PRESSURE, AIR
76	376034	1	FITTING, 1/4 BARB, 1/8-27 NPT
77	718922	1	SWITCH, PRESSURE
78	376014	1	FITTING, AIR INLET
79	M200162	AS REQ	ADHESIVE, LOCTITE #380 BLACK MAX

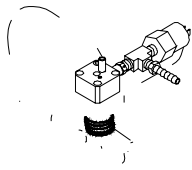

NOTE:
BARBED FITTING MUST BE
IN HORIZONTAL POSITION
WHEN TIGHTENED.

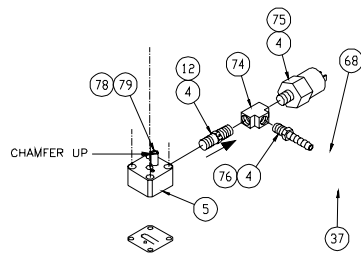
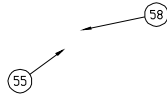
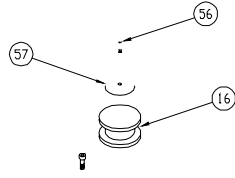

CHAMFER UP

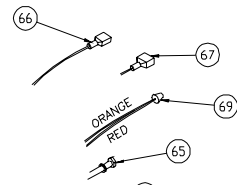

ORANGE
RED

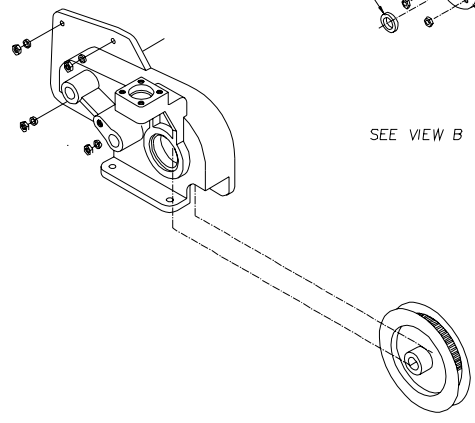
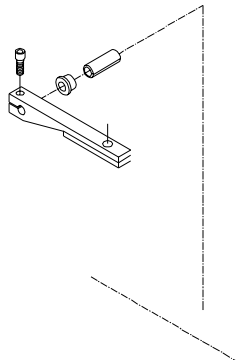
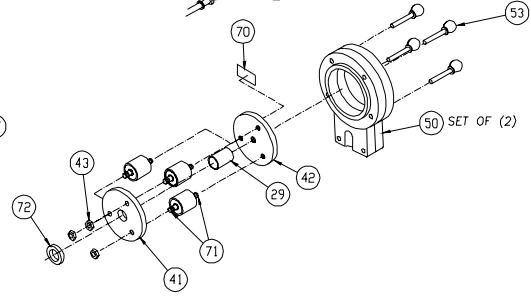

SEE VIEW B

U3-02 MAIN PUMP REMOVAL:

1. TURN TOGGLE SWITCH TO OFF.
2. UNPLUG POWER CORD FROM POWER SOURCE.
3. VENT OR RELIEVE PRESSURE IN HOSES OR FREEZER BEFORE REMOVING HOSES.
4. REMOVE 2 SCREWS SECURING SHEET METAL ENCLOSURE.
5. REMOVE AIR COMPRESSOR HOSE (LOCATED ABOVE ON/OFF SWITCH).
6. REMOVE TAN HOSE FROM PUMP HOUSING, THEN REMOVE (4) THUMBSCREWS TO ALLOW FOR REMOVAL OF COVER CLAMP.
7. CLIP WIRE TIES TO ALLOW WIRES TO BE DISCONNECTED.
8. REMOVE (3) HEX BOLTS FROM BOTTOM OF PUMP ENCLOSURE.
9. REMOVE MAIN PUMP ASSEMBLY (NOTE POSITION OF STAINLESS STEEL GUARD FOR REINSTALLATION LATER).
10. PROCEED TO REPAIR.

AIR COMPRESSOR KIT

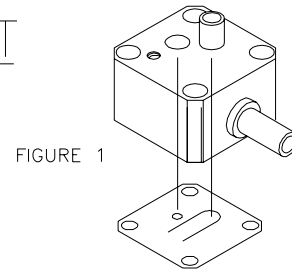
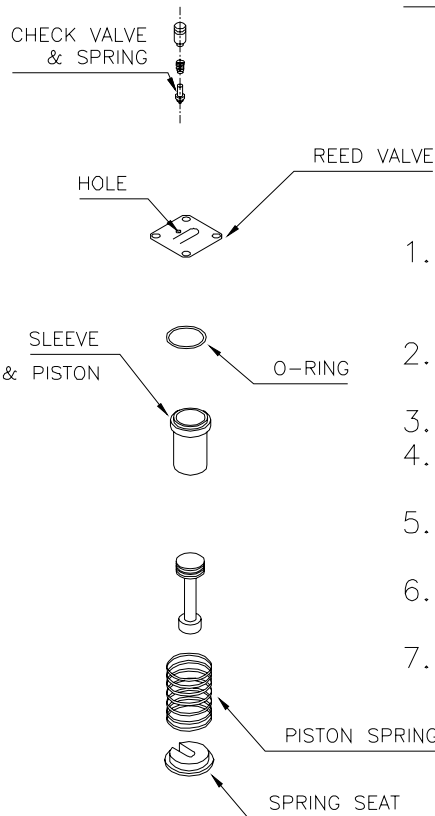

1. DIRT & DEBRIS WILL RUIN A NEW AIR COMPRESSOR. USE EXTREME CARE TO KEEP EVERY TOOL, PART & HANDS CLEAN.
2. REMOVE AIR FILTER & RETAINER (NOTE POSITION OF WASHER UNDER RETAINER).
3. REMOVE VALVE HEAD (4 ALLEN HEAD SCREWS).
4. REMOVE REED VALVE & O-RING (NOTE POSITION OF REED VALVE, SEE FIGURE 1).
5. REMOVE PISTON SPRING BY LOOSENING OVERRUN ECCENTRIC TO REDUCE SPRING TENSION.
6. REMOVE PISTON & CYLINDER BY LIFTING UP & OUT OF HOUSING. (DO NOT LOSE BALL BEARING)
7. REVERSE TO ASSEMBLY NEW PARTS & ADJUST OVERRUN SCALE TO PRIOR SETTING.

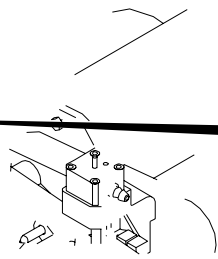

RETAINER

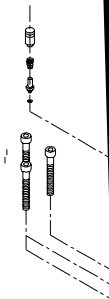



WARRANTY

MIX TRANSFER PUMPS / COCKTAIL / SLUSH

1. Scope:

Stoelting LLC warrants to the first user (the “Buyer”) that the evaporator assembly and compressor (if applicable) of Stoelting mix transfer pump, cocktail and slush equipment will be free from defects in materials and workmanship under normal use and proper maintenance appearing within five (5) years (two (2) years for “Mirage” equipment), and that all other components of such equipment manufactured by Stoelting will be free from defects in material and workmanship under normal use and proper maintenance appearing within twelve (12) months after the date that such equipment is originally installed.

2. Disclaimer of Other Warranties:

THIS WARRANTY IS EXCLUSIVE; AND STOELTING HEREBY DISCLAIMS ANY IMPLIED WARRANTY OF MERCHANTABILITY OR FITNESS FOR PARTICULAR PURPOSE.

3. Remedies:

Stoelting’s sole obligations, and Buyer’s sole remedies, for any breach of this warranty shall be the repair or (at Stoelting’s option) replacement of the affected component at Stoelting’s plant in Kiel, Wisconsin, or (again, at Stoelting’s option) refund of the purchase price of the affected equipment, and, during the first ninety (90) days of the warranty period, deinstallation/reinstallation of the affected component from/into the equipment. Those obligations/remedies are subject to the conditions that Buyer (a) signs and returns to Stoelting, upon installation, the Warranty Registration Card for the affected equipment, (b) gives Stoelting prompt written notice of any claimed breach of warranty within the applicable warranty period, and (c) delivers the affected equipment to Stoelting or its designated service location, in its original packaging/crating, also within that period. Buyer shall bear the cost and risk of shipping to and from Stoelting’s plant or designated service location.

4. Extensions:

The warranty period for deinstallation/reinstallation of the affected component from/into the equipment is extended to twelve (12) months on the following models: SO218, SO318, SO328. The warranty period for the drive motor to be free of defects in materials and workmanship extended to five (5) years on the following models: SO218, SO318, SO328.

5. Exclusions and Limitations:

This warranty does not extend to parts, sometimes called “wear parts”, which are generally expected to deteriorate and to require replacement as equipment is used, including as examples but not intended to be limited to o-rings, hoses, seals and drive belts. All such parts are sold

AS IS.

Further, Stoelting shall not be responsible to provide any remedy under this warranty with respect to any component that fails by reason of negligence, abnormal use, misuse or abuse, use with parts or equipment not manufactured or supplied by Stoelting, or damage in transit.

THE REMEDIES SET FORTH IN THIS WARRANTY SHALL BE THE SOLE LIABILITY STOELTING AND THE EXCLUSIVE REMEDY OF BUYER WITH RESPECT TO EQUIPMENT SUPPLIED BY STOELTING; AND IN NO EVENT SHALL STOELTING BE LIABLE FOR ANY INCIDENTAL OR CONSEQUENTIAL DAMAGES, WHETHER FOR BREACH OF WARRANTY OR OTHER CONTRACT BREACH, NEGLIGENCE OR OTHER TORT, OR ON ANY STRICT LIABILITY THEORY.

