

ELLIPTICAL

ELITE 2.0E

ELITE 3.0E

ELITE 4.0E

Owner's Guide



TABLE OF CONTENTS

SAFETY INSTRUCTIONS	3
GETTING STARTED/POWER	7
MOVING/FOOT POSITION	8
KNOW YOUR ELLIPTICAL (<i>Elite 2.0E</i>)	9
QUICK START UP (<i>Elite 2.0E</i>)	10
PROGRAMMING	11
DISPLAY (<i>Elite 2.0E</i>)	12
KNOW YOUR ELLIPTICAL (<i>Elite 3.0E & Elite 4.0E</i>)	13
QUICK START UP (<i>Elite 3.0E & Elite 4.0E</i>)	14
DISPLAY (<i>Elite 3.0E & Elite 4.0E</i>)	15
PROGRAM PROFILES	18
USING YOUR THR Zone™ PROGRAM	19
HEART RATE ZONE & MONITORING	21
TROUBLESHOOTING	22
COMMON PRODUCT QUESTIONS	24
EXERCISE GUIDELINES	25
ROUTINE MAINTENANCE	26
DEVELOPING A FITNESS PROGRAM & WARM UP & COOL DOWN	28
FOOT POSITIONING	29
FITNESS GOALS	30
WEEKLY LOG SHEETS	31
MONTHLY LOG SHEETS	32
HOME USE WARRANTY	33



CAUTION

Read all precautions and instructions in this manual before using this equipment.
Save this manual for future reference.

IMPORTANT SAFETY INSTRUCTIONS

SAVE THESE INSTRUCTIONS

When using an electrical product, basic precautions should always be followed. Read all instructions before using this exercise product.



WARNING!

To reduce the risk of burns, fire, electrical shock or injury to persons:

- Use this exercise product for its intended use as described in this Owner's guide. Do not use attachments not recommended by the manufacturer.
- Never drop or insert any object into any opening.
- Do not remove the elliptical trainer's side covers. Service should be performed only by an authorized Horizon Fitness service provider.
- Never operate this elliptical trainer if it has a damaged cord or plug, if it is not working properly, if it has been damaged, or immersed in water.
- Keep the cord away from heated surfaces.
- Do not use outdoors.
- Only use the power cord provided with your elliptical trainer.
- Never place the power cord under carpeting or place any object on top of the power cord, which may pinch or damage it.
- Unplug your elliptical trainer before moving it.

OTHER SAFETY TIPS FOR YOUR ELLIPTICAL TRAINER



CAUTION!

- If you experience chest pains, nausea, dizziness or shortness of breath, stop exercising immediately and consult your physician before continuing.
- Do not turn pedal arms by hand.
- Do not wear clothing that might catch on any part of the elliptical trainer.
- Make sure handlebars are secure before each use.
- Read the owner's guide before operating this elliptical trainer.
- Maintain a comfortable pace. Do not 'sprint' above 80 rpms on this machine.
- To maintain balance it is recommended to keep a grip on the handlebars while exercising, mounting or dismounting the machine.

OPERATION

It is essential that your elliptical trainer is used only indoors, in a climate controlled room. If your elliptical trainer has been exposed to colder temperatures or high moisture climates, it is strongly recommended that the elliptical trainer is warmed up to room temperature before first time use. Failure to do so may cause premature electronic failure.

CHILDREN

- Keep children off of your elliptical trainer at all times.
- When the elliptical is in use, young children and pets should be kept at least 10 feet away.

CLEANING

- Clean with soap and slightly damp cloth only. Never use solvents.

CONGRATULATIONS! on choosing a Elite Series elliptical trainer.

You've taken an important step in developing and sustaining an exercise program! Your elliptical trainer is a tremendously effective tool for achieving your personal fitness goals. Regular use of your elliptical trainer can improve the quality of your life in so many ways.

Here are just a few of the health benefits of aerobic exercise:

- Weight Loss
- A Healthier Heart
- Improved Muscle Tone
- Increased Daily Energy Levels
- Reduced Stress
- Help In Countering Anxiety and Depression
- An Improved Self Image

The key to reaping these benefits is to develop the exercise habit. Your new elliptical trainer will help you eliminate the obstacles that prevent you from getting in your exercise time. Inclement weather and darkness won't interfere with your workout when you use your elliptical trainer in the comfort of your home. This manual provides you with basic information for using and enjoying your new machine. A more complete knowledge of your new elliptical trainer will assist you in realizing your goal of a healthy lifestyle.



CAUTION: BEFORE BEGINNING ANY EXERCISE PROGRAM, ALWAYS CONSULT YOUR PHYSICIAN. IF YOU EXPERIENCE CHEST PAINS, NAUSEA, DIZZINESS OR SHORTNESS OF BREATH, STOP EXERCISING AND CONSULT YOUR PHYSICIAN BEFORE CONTINUING.

IMPORTANT: PLEASE READ BEFORE USE!

ASSEMBLY

CAUTION! There are several areas during the assembly process of a elliptical trainer that special attention must be paid. It is very important to follow the assembly instructions correctly and to make sure all parts are firmly tightened. If the assembly instructions are not followed correctly, the elliptical trainer could have frame parts that are not tightened and will seem loose and may cause irritating noises. To prevent damage to the elliptical trainer, the assembly instructions must be reviewed and corrective actions should be taken.

Before proceeding, find your elliptical trainer's serial number located under the left side cover for all models and enter it in the space provided below. Also locate the model name for all models which is located on the side cover. (see drawing below)

SERIAL NUMBER AND MODEL NAME LOCATION:

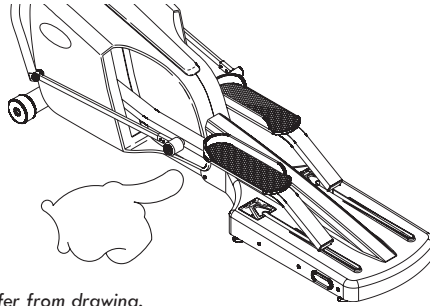

Note: Actual model may differ from drawing.

ENTER YOUR SERIAL NUMBER IN BOX BELOW:

Refer to this number when calling for service, and also enter this serial number on your Warranty Card and in your own records. Be sure to read the Safety Instructions and complete Owner's Guide before using your new elliptical trainer.

WARRANTY REGISTRATION

Your warranty card must be completed and sent to Horizon Fitness within thirty days of purchase or registered on line at www.horizonfitness.com, before a warranty claim can be processed. Please keep receipt with owner's guide as it may be required for a warranty claim. Make sure to send in warranty registration card to validate your warranty.

GETTING STARTED

POWER

The console on your (Elite 2.0E) is powered by 2 AA batteries, which are replaceable through the back side of the console. Your elliptical itself, is powered by you.

Your programmable (Elite 3.0E and Elite 4.0E) elliptical trainer is powered by a power supply. The power supply must be plugged into the power jack, which is located in the front of the machine near the front foot tube.

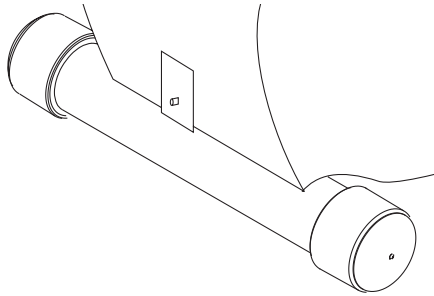

LEVELING (Elite 4.0E only)

The elliptical trainer should be level for optimum use. Once you have placed the elliptical trainer where you intend to use it, raise or lower the adjustable levelers located on the bottom of the rear base frame. Once you have leveled the elliptical trainer, lock the levelers in place by tightening the wing nuts against the frame.

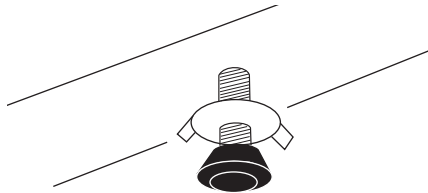

MOVING

Your elliptical trainer has a pair of transport wheels built into the front of the frame. To move, firmly grasp the back end of the frame for the Elite 4.0E and console mast for Elite 3.0E and 2.0E. Using the transport grips on the Elite 4.0E and the console mast on the Elite 3.0E and Elite 2.0E, carefully lift and roll.

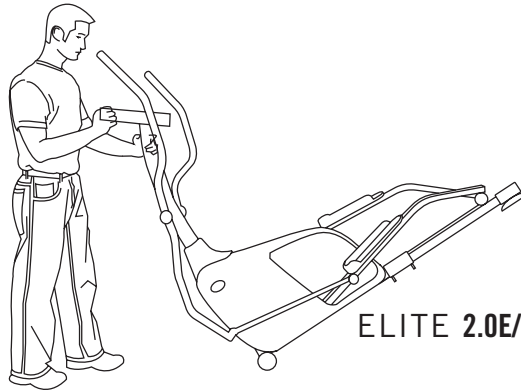

ELITE 2.0E/ 3.0E

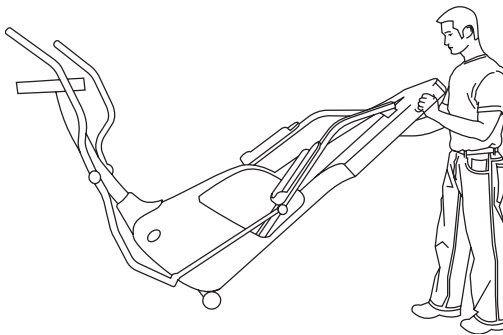

ELITE 4.0E



CAUTION! Our elliptical trainers are well built and heavy, weighing up to 200lbs.! Use care and additional help if necessary when moving.

KNOW YOUR ELLIPTICAL

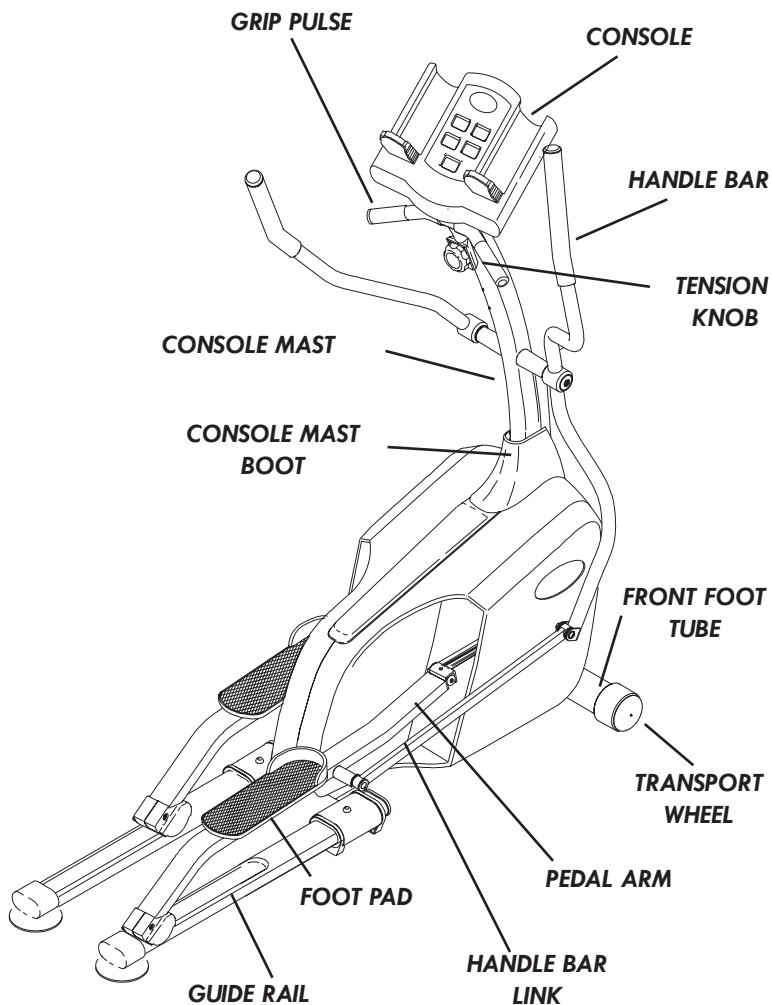

QUICK START UP

Simply begin exercising. The console will automatically begin counting up and tracking your information.

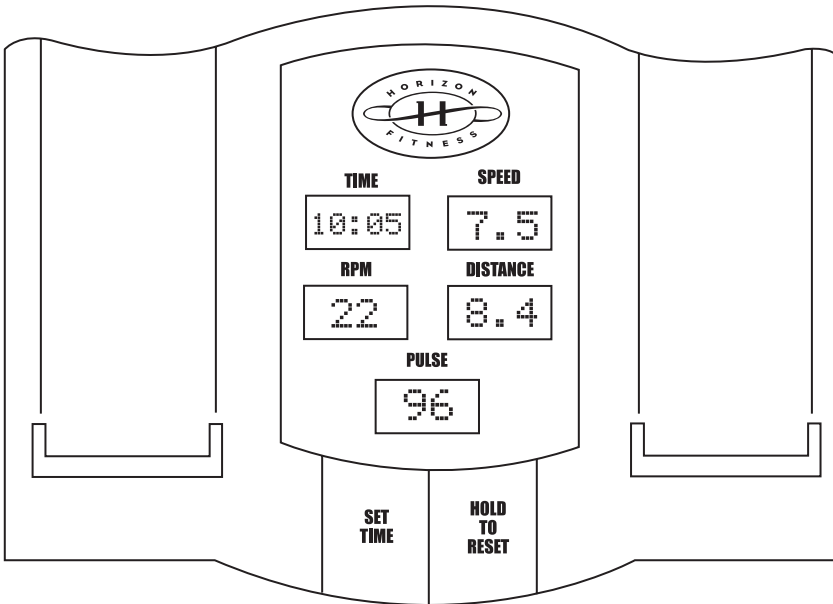

RESET

Press and hold the reset button on the console.

PROGRAMMING

CHOOSING YOUR TIME

Press the 'SET TIME' button on the console to select your workout time (time is set in 1 minute increments).

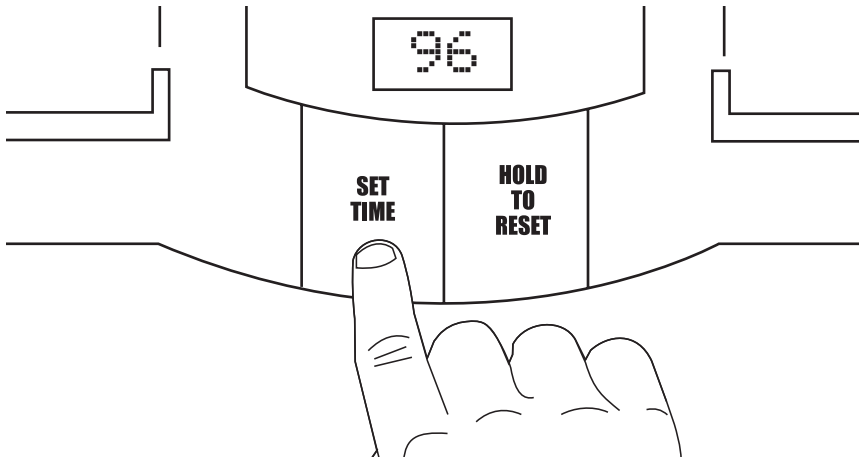

STARTING YOUR WORKOUT

Start pedaling, the console will automatically begin counting down.

FINISHING YOUR WORKOUT

Remember to gradually slow down your pace before stopping your workout. The machine will not stop moving if you stop your feet abruptly. After you have finished your workout, the console will 'beep' several times to let you know your workout is finished.

DISPLAY

TIME

Shown as Minutes:Seconds. View the time remaining or the time elapsed in your workout.

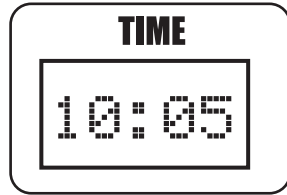

DISTANCE

Shown as Miles. View the accumulated distance during your workout.

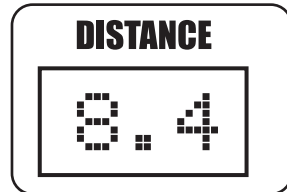

SPEED

Shown as your speed in miles per hour.

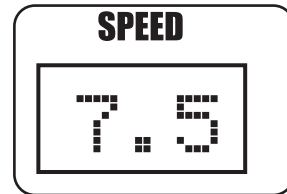

RPM

Shown as Revolutions per Minute. Improve striding technique while reducing leg muscle fatigue by striding between 60 & 70 RPM.

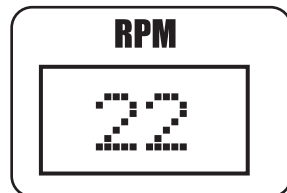

PULSE

Shown as Beats Per Minute. Used to monitor your heart rate during your workout (displayed when contact is made with both grips. Pulse can only be viewed while on the pulse screen).

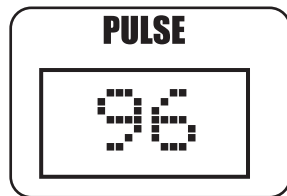

KNOW YOUR ELLIPTICAL

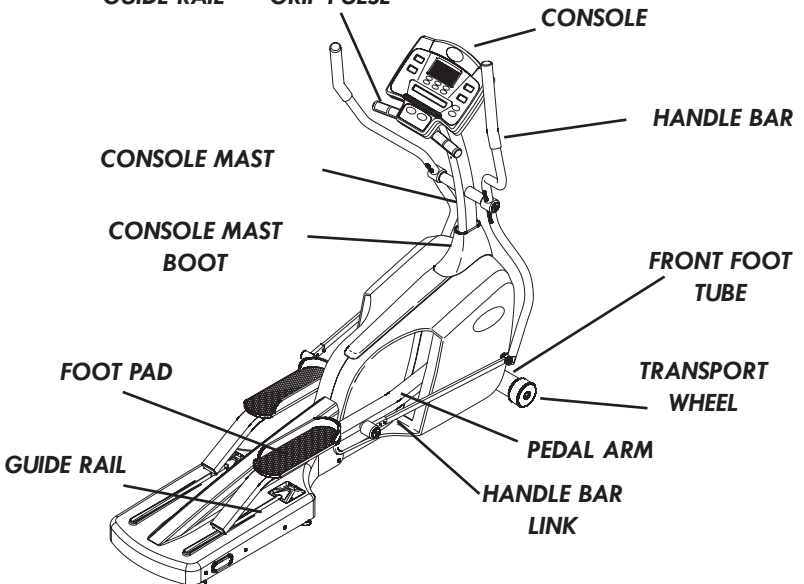
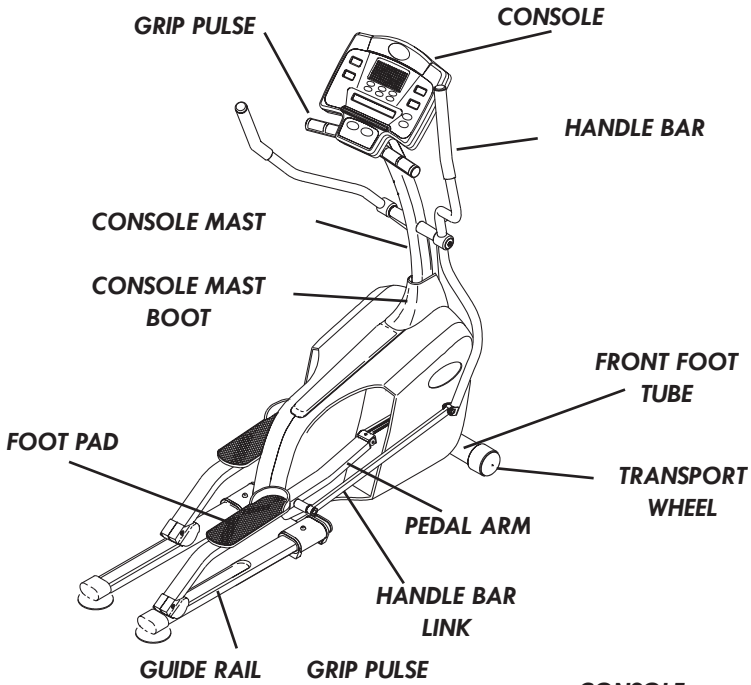

QUICK START UP

Simply press the 'Start' button to begin exercising. The program will automatically default to the Manual program unless another program is selected.

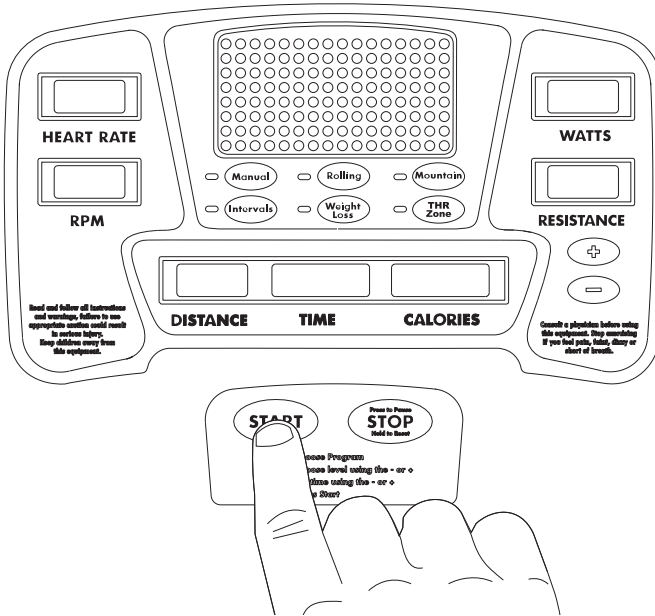

RESET

Press and hold the Stop button to reset the Elliptical Trainer.

DISPLAY

TIME

Shown as Minutes:Seconds. View the time remaining or the time elapsed in your workout.

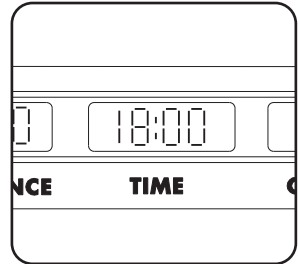

DISTANCE

Shown as Miles. View the accumulated distance during your workout.

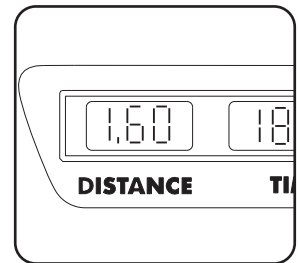

CALORIES

Shown as total accumulated calories burned during your workout.

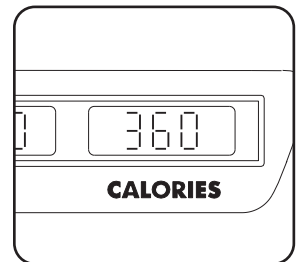

RPM

Shown as Revolutions per Minute. Improve striding technique while reducing leg muscle fatigue by striding between 60 & 70 RPM.

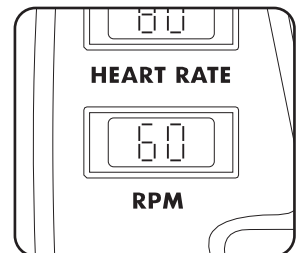

DISPLAY

RESISTANCE

During a workout, the amount of resistance can be adjusted by pressing the plus (+) or minus (-) buttons on the console. The resistance levels vary from level 1 to 16 (level 1 being the easiest and level 16 being the most difficult).



WATTS

A measurement of your expending energy. May be used to evaluate and quantify your fitness progress over time.

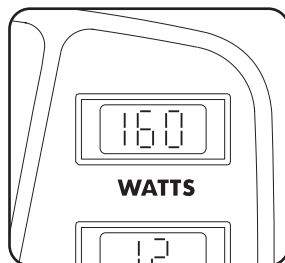

HEART RATE

Shown as Beats per Minute. You can monitor your heart rate at any time during your workout by holding the heart rate grips or wearing the chest transmitter.

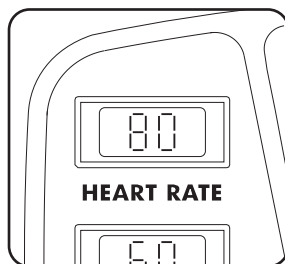

PROFILE

Allows you to view your program intensity while you exercise. Each horizontal row of LED's represents 2 resistance levels.

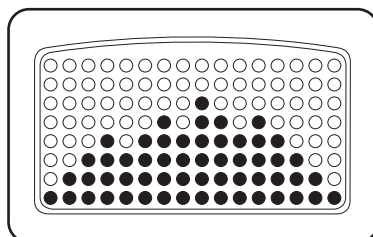

CHOOSING A PROGRAM

To choose a program, press the quick program key. The program profile lights will show you which program you have selected. Once you choose a program, wait for 5 seconds and you will see the resistance level flashing in the Resistance window.

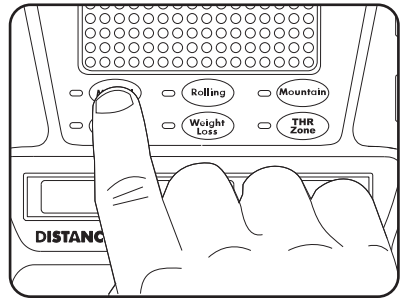

CHOOSING A RESISTANCE

With the resistance level flashing, press the plus (+) or minus (-) buttons to adjust your resistance level. Once you choose a resistance level, wait for 5 seconds and you will see the time flashing in the Time window.

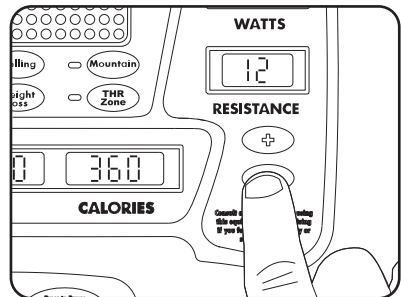

CHOOSING A TIME

With the time flashing, press the plus (+) or minus (-) buttons to adjust your program time. Once you choose your time, press the 'Start' button and begin your workout.

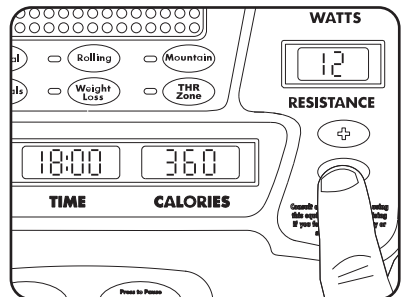

FINISHING YOUR WORKOUT

Press the 'Stop' button to pause your workout, press and hold to reset your workout. Remember to gradually slow down your pace before stopping or pausing your workout. The machine will not stop moving if you stop your feet abruptly. After you have finished your workout, the console will retain the data from your workout for 45 seconds before resetting.

PROGRAM PROFILES

MANUAL

Customized workouts, allowing the user to adjust resistance level to the user's preference.

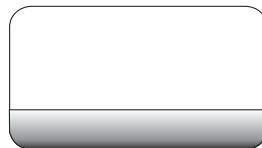

INTERVALS

Improves your strength, speed, and endurance by raising and lowering the resistance levels throughout your workout to involve both your heart and muscles.

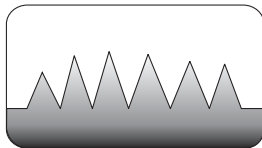

ROLLING

Maintains weight by gradually raising and lowering the resistance level to gradually raise and lower your heart rate.

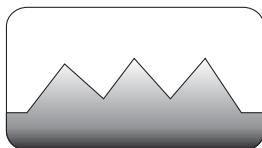

WEIGHT LOSS

Promotes weight loss by raising and lowering the resistance level, while keeping you in your fat burning zone.

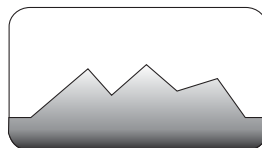

MOUNTAIN

Improves performance and stamina by raising the resistance level to high peaks to simulate the most difficult outdoor terrains.

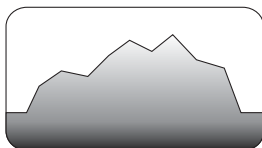

THR Zone™

Benefits weight loss by maintaining an optimum exercise level to burn fat, while adjusting the resistance to keep you in your target heart rate zone.

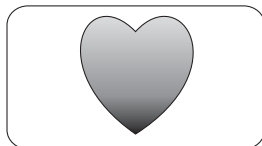

USING YOUR THR Zone™ PROGRAM

Once the 'THR Zone' quick program key is selected, wait for 5 seconds and you will see the target heart rate flashing in the Heart Rate window. Using the chart on page 21, determine your target heart rate. Your target heart rate should be set at a number that you will be able to exercise at throughout the majority of your workout. To adjust the target heart rate, press the plus (+) or minus (-) buttons.

Once you have chosen your target heart rate, wait for five seconds and you will see the time flashing in the Time window. Press the plus (+) or minus (-) buttons to adjust your time. Once you choose your time, press the 'Start' button and begin your workout.

The 'THR Zone' program will have a 5 minute warm up time before it will get you in your 'target heart rate zone'.

After the 5 minute warm up period, the resistance level will increase gradually to get the user to the entered 'target heart rate zone'. Once the user is at the 'target heart rate zone', plus or minus 5 beats, the resistance level will remain at the current resistance level.

The last 5 minutes of the program will begin the cool down period. At this time, the program will gradually decrease the resistance level to give the user a smooth cool down.

NOTE: The Chest Strap Transmitter is required to use the 'THR Zone' program.

CHEST STRAP TRANSMITTER PLACEMENT AND MOISTENING THE ELECTRODES

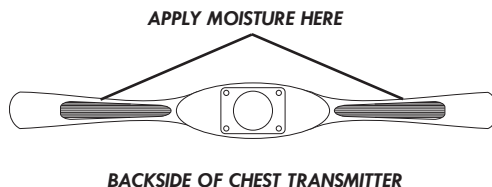
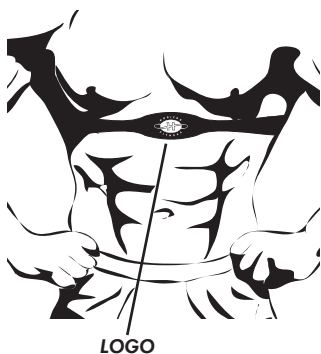

MONITORING YOUR HEART RATE

FEEDBACK

Your elliptical trainer offers two heart rate feedback options. You may choose to use the heart rate handlebars, or the chest transmitter for a hands free workout.

HEART RATE HANDLEBAR

Place the palm of your hands directly on the heart rate handlebars. Both hands must grip the bars for your heart rate to register. When gripping the handlebars, do not grip tightly. Holding the grips tightly may elevate your blood pressure. Try to maintain moderate pressure while holding onto the heart rate handlebars. It is recommended that you hold the handlebars only long enough to see your heart rate readout on the console. You may experience an erratic readout if consistently holding the handlebars.

TELEMETRIC CHEST TRANSMITTER (Elite3.0E and Elite 4.0E only)

Prior to wearing the chest transmitter on your chest, moisten the two rubber electrodes with water. Center the chest strap just below the breast or pectoral muscles, directly over your sternum, with the Horizon Fitness logo facing out. Note: The chest strap must be tight and properly placed to receive an accurate and consistent readout. If the chest strap is too loose, or positioned improperly, you may receive an erratic or inconsistent heart rate readout.

If you have any problems with the heart rate function please refer to (pages 22 & 23) in the troubleshooting section.

WARNING!

The heart rate function is not a medical device. Various factors may affect the accuracy of your heart rate reading. The heart rate reading is intended only as an exercise aid.

THR Zone™

TARGET HEART RATE ZONE

Your 'Target Heart Rate Zone' is a percentage of your maximum heart rate. Target Zones will vary for each individual, depending on age, current level of conditioning, and personal fitness goals. The American Heart Association recommends working-out at a 'Target Heart Rate Zone' of between 60% and 75% of your maximum heart rate. See the chart below for convenient reference. **EXAMPLE** for a 42-year old user: find AGE along the bottom of the chart (round to 40), follow AGE column up to the TARGET ZONE BAR. RESULTS: 60% of maximum Hear Rate = 108 Beats Per Minute, 75% of maximum Heart Rate = 135 Beat Per Minute.

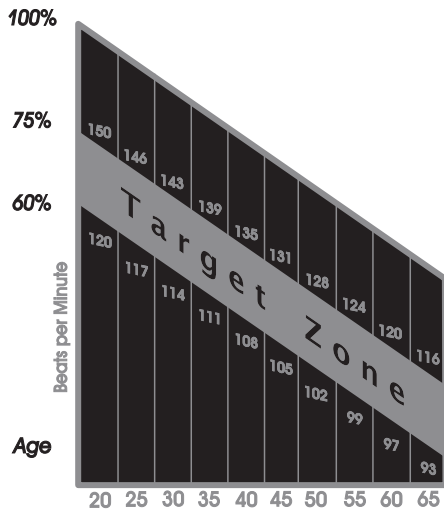

TROUBLESHOOTING YOUR ELLIPTICAL TRAINER

Your Horizon Fitness elliptical is designed to be reliable and maintenance free. However, if you do experience problems with your elliptical, please reference the troubleshooting guide listed below.

PROBLEM: There is no display on the console.

SOLUTION: Remove the console and verify that the console cable is attached properly, making sure that the cable is securely inserted into the console.

PROBLEM: The elliptical trainer makes a squeaking or chirping noise.

SOLUTION: Loosen all bolts attached during the assembly process, grease the threads and tighten again.

PROBLEM: The resistance levels seem to be incorrect, seeming too hard or too easy.

SOLUTION: Reset the console and allow the resistance to reset to the default position. Restart the console and retry the resistance levels.

PROBLEM: Roller wheels appear to be leaving particles on the guiderails.

SOLUTION: This is considered normal wear of the elliptical wheels. To remove, simply wipe off the roller wheels and guide rails with a damp cloth.

HEART RATE TROUBLESHOOTING

PROBLEM: There is no heart rate reading

SOLUTION: Remove the console and verify that the heart rate cables are attached properly, making sure that the cables are securely inserted into the console.

SOLUTION: If you are using the chest strap, there may be a poor connection between the electrodes and the skin. Remoisten the electrodes with water.

SOLUTION: The chest strap may not be positioned properly. Reposition the chest strap. It may be necessary to experiment with the fit and position of the chest strap.

SOLUTION: Verify that the distance between the chest strap and the console is not beyond the recommended range of 36 inches.

SOLUTION: The battery in the chest strap may be dead. Take the chest strap to a jewelry store or return to Horizon Fitness for a battery replacement.

PROBLEM: Erratic or Inconsistent Readout.

SOLUTION: This is often caused by dry electrodes or a loose chest strap. (Elite 3.0E and Elite 4.0E only) Moisture on the rubber electrodes is required for proper operation. Try a more generous coating of water on the electrodes and tightening the chest strap.

Chest your exercise environment for sources of interference such as high power lines, large motors, etc.

You may experience an erratic readout under the following conditions:

- Gripping the heart rate handlebars too tight. Try to maintain moderate pressure while holding onto the heart rate handlebars.
- Constant movement and vibration due to constantly holding the heart rate grips while exercising.
- When you are breathing heavily during a workout.
- When your hands are constricted by wearing a ring.
- When your hands are dry or cold. Try moistening your palms or rubbing them together to warm.
- Anyone with heavy arrhythmia.
- Anyone with arteriosclerosis or peripheral circulation disorder.
- Anyone whose skin on the measuring palms is especially thick.

Note: Outside interference sources such as computers, motors and fluorescent lights may cause the heart rate reading to be erratic.

**If the above troubleshooting section does not remedy the problem,
discontinue use and turn the power off.**

**DO NOT RETURN TO THE STORE, PLEASE CONTACT THE
HORIZON FITNESS CUSTOMER ASSISTANCE CENTER
TOLLFREE @ 1-888-993-3199
www.horizonfitness.com**

COMMON PRODUCT QUESTIONS

ARE THE SOUNDS MY ELLIPTICAL TRAINER MAKES NORMAL?

Our elliptical trainers are some of the quietest available because they use belt drives and friction free magnetic resistance. We use the highest grade bearings and belts to minimize noise. However, because the resistance system itself is so quiet, you will occasionally hear other slight mechanical noises. Unlike older, louder technologies, there are no fans, friction belts, or alternator noises to mask these sounds on our elliptical trainers. These mechanical noises, which may or may not be intermittent, are normal and are caused by the transfer of significant amounts of energy to a rapidly spinning flywheel. All bearings, belts and other rotating parts will generate some noise which will transmit through the casing and frame. It is also normal for these sounds to change slightly during a workout and over time because of thermal expansion of the parts.

WHY IS THE ELLIPTICAL TRAINER I HAD DELIVERED LOUDER THAN THE ONE AT THE STORE?

All fitness products seem quieter in a large store showroom because there is generally more background noise than in your home. Also, there will be less reverberation on a carpeted concrete floor than on a wood overlay floor. Sometimes a heavy rubber mat will help reduce reverberation through the floor. If a fitness product is placed close to a wall, there will be more reflected noise.

HOW LONG WILL THE DRIVE BELT LAST?

The computer modeling we have done indicated virtually thousands of maintenance free hours. Belts are now commonly used in far more demanding applications such as motorcycle drives.

CAN I MOVE THE TRAINER EASILY ONCE IT IS ASSEMBLED?

Your elliptical trainer has a pair of transport wheels built into the front legs. It is easy to move your Elliptical Trainer by rolling it on the front transport wheels. It is important that you place your elliptical trainer in a comfortable and inviting room. Your Elliptical Trainer is designed to use minimal floor space. Many people will place their Elliptical Trainers facing the TV or a picture window. If at all possible, avoid putting your Elliptical Trainer in a unfinished basement. To make exercise a desirable daily activity for you, the Elliptical Trainer should be in a attractive setting.

CAN I PEDAL BACKWARDS ON MY ELLIPTICAL TRAINER?

Your elliptical trainer allows you to pedal both forward and backwards to exercise and strengthen a wider range of muscles.

EXERCISE GUIDELINES

Always consult your physician before beginning an exercise program.

HOW OFTEN?

The American Heart Association recommends that you exercise at least 3 to 4 days per week to maintain cardiovascular fitness. If you have other goals such as weight or fat loss, you will achieve your goal faster with more frequent exercise. Whether it's 3 days or 6 days, remember that your ultimate goal should be to make exercise a lifetime habit. Many people are successful staying with a fitness program if they set aside a specific time of day to exercise. It doesn't matter whether it's in the morning before your shower, during lunch hour or while watching the evening news. What's more important is that it's a time that allows you to keep a schedule, and a time when you won't be interrupted. If you are to be successful with your fitness program, you have to make it a priority in your life. So decide on a time, pull out your day planner and pencil in your exercise times for the next month!

HOW LONG?

For aerobic exercise benefits, it's recommended that you exercise from between 24 and 32 minutes per session. But start slowly and gradually increase your exercise times. If you've been sedentary during the past year, it may be a good idea to keep your exercise times to as little as five minutes initially. Your body will need time to adjust to the new activity. If your goal is weight loss, a longer exercise session at lower intensities has been found to be most effective. A workout time of 48 minutes or more is recommended for best weight loss results.

ROUTINE MAINTENANCE



WHAT KIND OF ROUTINE MAINTENANCE IS REQUIRED?

We use sealed bearings throughout our ellipticals so lubrication is not needed. The most important maintenance step is to simply wipe your perspiration off the trainer after each use.

HOW DO I CLEAN MY HORIZON FITNESS ELLIPTICAL TRAINER?

Clean with soap and water cleaners only. Never use solvents on plastic parts.

Cleanliness of your elliptical trainer and its operating environment will keep maintenance problems and service calls to a minimum. For this reason, Horizon Fitness recommends that the following preventive maintenance schedule be followed.



AFTER EACH USE (DAILY)

Turn off the elliptical trainer with the on/off switch, and unplug the power cord from the wall outlet.

WARNING!

To remove power from the elliptical, the power cord must be disconnected from the wall outlet. (Elite 3.0E and Elite 4.0E)

- Wipe down the elliptical trainer with a damp cloth. Never use solvents, as they can cause damage to the elliptical.
- Inspect the power cord. If the power cord is damaged, contact Horizon Fitness.
- Make sure the power cord is not underneath the elliptical trainer or in any other area where it can become pinched or cut.

EVERY WEEK

Clean underneath the elliptical, following these steps:

- Turn off the elliptical trainer with the on/off switch.
- Then unplug the power cord at the wall outlet. (Elite 3.0E and Elite 4.0E)
- Move the elliptical trainer to a remote location.
- Wipe or vacuum any dust particles or other objects that may have accumulated underneath the elliptical trainer.
- Return the elliptical trainer to its previous position.

EVERY MONTH

- Inspect all assembly bolts and pedals on the machine for proper tightness.
- Clean any debris off of the pedal arm wheels and guide rails.

HOW HARD?

How hard you workout is also determined by your goals. If you use your elliptical trainer to prepare for a 5K run, you will probably work out at a higher intensity than if your goal is general fitness. Regardless of your long term goals, always begin an exercise program at low intensity. Aerobic exercise does not have to be painful to be beneficial! There are two ways to measure your exercise intensity. The first is by monitoring your heart rate, and the second is by evaluating your perceived exertion level (this is simpler than it sounds!). Note: Always consult your physician before beginning an exercise program.

PERCEIVED EXERTION LEVEL

The second and simpler way to gauge your exercise intensity is to evaluate your perceived exertion level. While exercising if you are too winded to maintain a conversation without gasping, you are working out too hard. A good rule of thumb is to work to the point of exhilaration, not exhaustion. If you cannot catch your breath, it's time to slow down. Always be aware of other warning signs of overexertion.

DEVELOPING A FITNESS PROGRAM

STRETCH FIRST

Before using your Horizon Fitness product, it is best to take a few minutes doing a few gentle stretching exercises. Stretching prior to exercise will improve flexibility and reduce chances of exercise related injury. Ease into each of these stretches with a slow gentle motion. Do not stretch to the point of pain. Make sure not to bounce while doing these stretches.

WALL PUSH

Stand near a wall with the toes of one foot about 18" from the wall, and the other foot about 12" behind the other foot. Lean forward, pushing against the wall with your palms. Keep your heels flat and hold this position for a count of 15 seconds. Make sure that you do not bounce while stretching. Alternate positions of your feet and repeat for a total of 8 repetitions.

STANDING QUADRICEPS STRETCH

Using a wall to provide balance, grasp your left ankle with your left hand and hold your foot against the back of your thigh for a count of 15 seconds. Repeat with your right ankle and hand, and continue alternating for a total of 8 repetitions.

SEATED TOE TOUCH

Sit on the floor with your legs together and straight out in front of you. Do not lock your knees. Extend your fingers towards your toes and hold for a count of 15 seconds. Make sure that you do not bounce while stretching. Sit upright again. Repeat for a total of 8 repetitions.

THE IMPORTANCE OF WARM UP AND COOL DOWN

WARM UP

The first 2 to 5 minutes of a workout should be devoted to warming up. The warm-up will limber your muscles and prepare them for more strenuous exercise. Make sure that you warm-up on your Horizon Fitness product at a slow pace.

COOL DOWN

Never stop exercising suddenly! A cool-down period allows your heart to readjust to the decreased demand. Make sure that your cool down period consists of a very slow pace to allow your heart rate to lower. After the cool-down, repeat the stretching exercises (listed above) to loosen and relax your muscles.

FOOT POSITIONING

Your elliptical trainer offers a variety of foot positions. Moving your foot to the forward most position of the foot pad increases your step height, which will create a feel similar to a step machine. Placing your foot toward the back of the foot pad decreases your step height and creates more of a gliding feel, similar to a smooth walk or run.

Your elliptical trainer also allows you to pedal both forward and backwards to offer a variation to your workout and to focus on other major leg muscle groups such as your hamstrings and calves.

ACHIEVING YOUR FITNESS GOALS

An important step in developing a long term fitness program is to determine your goals. Is your primary goal for exercising on your elliptical trainer to lose weight? Improve muscle? Burn Stress? Prepare for the spring racing schedule? Knowing what your goals are will help you develop a more successful exercise program. Below are some common exercise goals:

- Weight Loss
- Improve Body Shape and Tone
- Increased Energy Level
- Improved Sports Performance
- Improved Cardiovascular Endurance
- Weight Maintenance
- Strengthen Leg Muscles
- Improved Sleep Patterns
- Stress Reduction

If possible try to define your personal goals in precise, measurable terms, and then put your goals in writing. The more specific you can be, the easier it will be to track your progress. If your goals are long term, divide them up into monthly and weekly segments. Longer term goals can lose some of the immediate motivation benefits. Short term goals are easier to achieve. Your elliptical trainer console provides you with several readouts that can be used to record your progress. You can track Distance, Calories or Time. Time is the most important and useful of test functions.

KEEPING AN EXERCISE DIARY

Photocopy the weekly and monthly log sheets on the following pages to make your personal exercise log book. As time goes by you'll be able to look back with pride at the work you've done. As your fitness improves, you can look back and see how far you've come.

WEEKLY LOG SHEET

WEEK # _____		WEEKLY GOAL: _____			
DAY	DATE	DISTANCE	CALORIES	TIME	COMMENTS
SUN					
MON					
TUES					
WED					
THUR					
FRI					
SAT					
WEEKLY TOTALS					

WEEK # _____		WEEKLY GOAL: _____			
DAY	DATE	DISTANCE	CALORIES	TIME	COMMENTS
SUN					
MON					
TUES					
WED					
THUR					
FRI					
SAT					
WEEKLY TOTALS					

MONTHLY LOG SHEET

MONTH _____		MONTHLY GOAL: _____	
WEEK #	DISTANCE	CALORIES	TIME
MONTHLY TOTALS			

MONTH _____		MONTHLY GOAL: _____	
WEEK #	DISTANCE	CALORIES	TIME
MONTHLY TOTALS			

LIMITED HOME USE WARRANTY

FRAME - LIFETIME

Horizon Fitness warrants the frame against defects in workmanship and materials for the lifetime of the original owner.

BRAKE - LIFETIME

Horizon Fitness warrants the brake against defects in workmanship and materials for the lifetime of the original owner.

ELECTRONICS & PARTS - 2 YEARS

Horizon Fitness warrants the electronic components and all original parts for a period of two years from the date of original purchase, so long as the device remains in the possession of the original owner.

LABOR - 1 YEAR

Horizon Fitness shall cover the labor cost for the repair of the device for a period of one year from the date of the original purchase, so long as the device remains in the possession of the original owner.

EXCLUSIONS AND LIMITATIONS

This warranty applies only to the original owner and is not transferable. This warranty is expressly limited to the repair or replacement of a defective frame, electronic component, or defective part and is the sole remedy of the warranty. The warranty does not cover normal wear and tear, improper assembly or maintenance, or installation of parts or accessories not originally intended or compatible with the elliptical trainer as sold. The warranty does not apply to damage or failure due to accident, abuse, corrosion, discoloration of paint or plastic, or neglect. Horizon Fitness shall not be responsible for incidental or consequential damages. All returns must be pre-authorized by Horizon Fitness. Horizon Fitness' obligation under this warranty is limited to replacing or repairing, at Horizon Fitness' option, the product at one of its authorized service centers. An Horizon Fitness authorized service center must receive all products for which a warranty claim is made. These products must be received with all freight and other transportation charges prepaid, accompanied by sufficient proof of purchase. Parts and electronic components reconditioned to As New Condition by Horizon Fitness or its vendors may sometimes be supplied as warranty replacement parts and constitute fulfillment of warranty terms. This warranty gives you specific legal rights, and your rights may vary from state to state. This warranty is applicable to sales made only by Horizon Fitness, its affiliates, subsidiaries and authorized distributors of Horizon Fitness products within the U.S. and Canada.

WARRANTY REGISTRATION

Your warranty card must be completed and sent to Horizon Fitness or register on line at www.horizonfitness.com, before a warranty claim can be processed.



Designed for life.™

HORIZON FITNESS
800 BURTON BOULEVARD
DEFOREST, WISCONSIN 53532
phone 1.888.993.3199 fax 1.608.842.1660
www.horizonfitness.com