



CTB-50



CTB-100



CTB-200

COUNTER TOP COOLERS

CTB-50/CTB-100/CTB-200

Key Features

- Top Mounted Forced Air Refrigeration
- Illuminated Header
- Bright Interior Lighting
- Adjustable Thermostat
- Self Closing Reversible Door
- Brushed Aluminum Door Frame
- Door Lock
- Adjustable Wire Shelves

Model	Doors	Capacity cu.ft (lt)	Shelves	Exterior Dimensions inches (mm)			Interior Dimensions inches (mm)			Power (V-Hz-Ph)	Amps	HP	Crated Weight lbs (kg)
				L	D	H	L	D	H				
CTB-50	1	5/8 (17)	1	11 5/8 (295)	13 5/8 (345)	21 1/2 (545)	9 (230)	10 1/8 (257)	12 1/4 (309)	115.60.1	2	1/10	38 (18)
CTB-200	1	2 1/8 (61)	2	17 1/8 (435)	17 7/8 (455)	27 3/4 (705)	14 3/8 (364)	13 1/4 (337)	17 1/2 (445)	115.60.1	2 1/2	1/8	70 (32)
CTB-100	1	3 1/8 (88)	2	18 7/8 (480)	20 1/8 (510)	31 7/8 (810)	16 1/8 (409)	15 3/8 (391)	21 5/8 (549)	115.60.1	2 1/2	1/8	99 (45)

Details

Cabinet Construction

- Exterior: Galvanized, pre-painted steel cabinet, gray.
- Interior: Durable ABS Plastic lining allows for easy cleaning.
- High-density, CFC-Free, polyurethane insulation.
- Illuminated header panel for attractive branding.
- Four (4) low profile adjustable feet. 4 inch legs are also included.

Door

- Self-closing reversible door with brushed aluminum frame and recessed side handle.
- Low-E, tempered, thermal glass door for increased efficiency and maximum product visibility.
- Strong magnetic gasket ensures a tight seal.
- Built-in door lock for added security.

Shelving

- Heavy-duty galvanized wire shelves:
 - CTB-50: 9" x 7 5/8" (229 x 194)
 - CTB-200: 14 3/8" x 10 5/8" (365 x 270)
 - CTB-100: 16" x 12 3/4" (406 x 324)
- Shelves slide into plastic liner and are easily adjustable to multiple positions.

Lighting

- Bright fluorescent lighting provides for maximum illumination of products.
- Utilizes T8 bulbs and an electronic ballast for increased energy efficiency and extended life.

Electrical

- Ready for connection to 115V/60Hz single phase 20 amp outlet.
- Includes an 8' cord and plug set.



NEMA 5-15R

Refrigeration System

- Forced air, environmentally friendly refrigeration system using CFC-free R134A refrigerant.
- Self-contained heated drain pan and condensate evaporation system.
- Automatic self-defrost cycle.
- Electronic temperature control maintains 34°F to 41°F (1°C to 5°C).
- Top mounted refrigeration unit allows for easy maintenance and service.

Options

- 208-230V/ 50Hz
- Custom Graphics
- Additional Shelves
- Pass Through Model Available
- Various Cabinet Colors

Technical Drawing

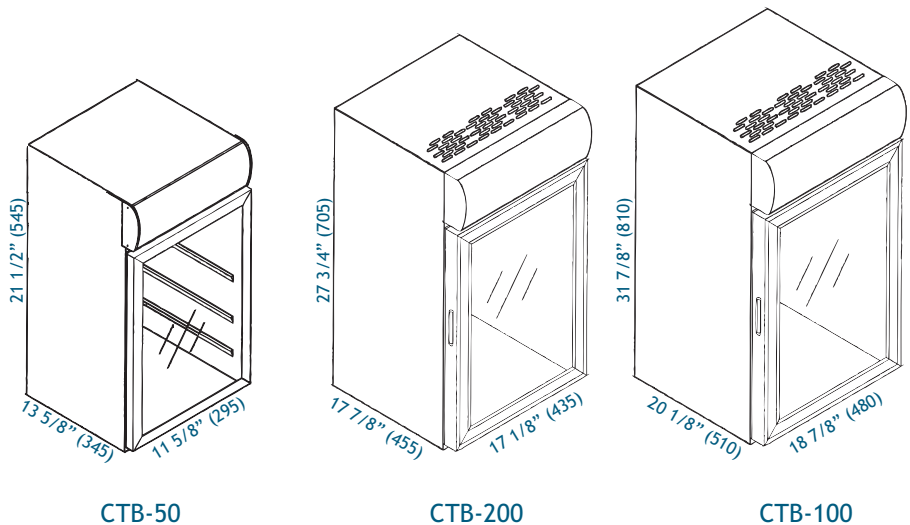

CTB-50/CTB-100/CTB-200



3235 Industry Drive • Suite C
North Charleston, SC 29418
Phone: 843-767-6855
Toll Free: 800-905-4768

Fax: 843-767-6858
Toll Free Fax: 800-906-4768
www.atcgroup.net
sales@atcgroup.net

WARRANTY

One year warranty on all parts and labor and an additional 4 year prorated warranty on compressor.