



INSTRUCTION MANUAL

10 CUP COFFEE MAKER

MODEL NO: XQ-698T

ITEM #6537



PLEASE READ AND SAVE THESE INSTRUCTIONS TO ENSURE THE SAFE AND EFFECTIVE USE OF THIS APPLIANCE

TABLE OF CONTENTS

Table of Contents	P. 2
Important Safeguards	P. 3
General Safety Rules	P. 4
List of Main Parts	P. 5
Technical Specifications, Contents of Packaging	P. 5
Before First Use	P. 6
Operation	P. 6
Maintenance	P. 7
Permanent Filter, Storing	P. 7
Service Center	P. 7
Warranty Information	P. 8
Warranty Card	P. 9
Spare Part Order Form	P. 10



IMPORTANT SAFEGUARDS

1. **Please read and save these instructions before using the appliance.**
2. Close supervision is necessary when any appliance is used near children.
3. Do not open top cover while coffee is brewing.
4. Household use only. Do not use outdoors.
5. Never use the appliance near hot surfaces.
6. Unplug unit from outlet when not in use and before cleaning. Allow cooling before putting on or taking off parts, and before cleaning the appliance.
7. To protect against electric shock, do not immerse cord, plugs, or appliance in water or other liquid.
8. Do not operate any appliance with a damaged cord or plug, or after the appliance malfunctions, or has been damaged in any manner. Return appliance to the nearest authorized service facility for examination, repair or adjustment.
9. Never use accessories which are not recommended by the manufacturer. They could constitute a danger to the user and risk damage to the appliance.
10. Never move the appliance by pulling the cord. DO NOT let the electrical cord hang over the edge of a table or counter or touch hot surfaces.
11. Stand the appliance on a table or flat surface.
12. Make sure the cord never comes into contact with the hot parts of the appliance.
13. Do not touch hot surfaces. Always use the glass carafe handle.
14. Be careful not to get burned by the steam evaporating from the coffee filter.
15. Never use the appliance if the glass carafe shows any signs of cracks. Only use the glass carafe with this appliance. Handle with care as the glass is very fragile.
16. Snap lid securely onto glass carafe before serving coffee.
17. Never use your coffee maker without water in it.
18. Do not place glass carafe on or near a hot gas or electric burner or in a heated oven.
19. Do not set hot glass carafe on a wet or cold surface.
20. Do not clean glass carafe with cleaners, steel wool pads, or other abrasive material.
21. To disconnect, turn switch to "off", then remove plug from wall outlet.
22. Do not use coffeemaker with a damaged outlet.
23. Do not remove glass carafe from heating plate while water is dripping from spout.
24. Do not forget that the temperature of the coffee prepared is high. Handle with care your glass carafe to avoid any risk of splashes.
25. Any examination, repair, or adjustment for the appliance should be made by the authorized service agent.
26. Do not use this appliance other than intended use.

SAVE THESE INSTRUCTIONS!

GENERAL SAFETY RULES



WARNING! Read and understand all instructions. Failure to follow all instructions listed below may result in electric shock, fire or serious personal injury. The warnings, cautions, and instruction discussed in this instruction manual cannot cover all possible conditions and situations that may occur. It must be understood by the operator that common sense and caution are a factor which cannot be built into this product, but must be supplied by the operator.

SAVE ALL INSTRUCTIONS!

CAUTION: A short power supply cord is provided to reduce the risk of personal injury resulting from becoming entangled in or tripping over a longer cord. Extension cords are available from local hardware stores and may be used if care is exercised in their use. If an extension cord is required, special care and caution is necessary. Also the cord must be: (1) marked with an electrical rating of 125 V, and at least 13 A., 1625 W., and (2) the cord must be arranged so that it will not drape over the countertop or tabletop where it can be pulled on by children or tripped over accidentally.

ELECTRIC POWER

If electric circuit is overloaded with other appliances, your appliances may not operate properly. The appliances should be operated on a separate electrical circuit from other operating appliances.

POLARIZED PLUG

This appliance has a polarized plug (one blade is wider than the other). As a safety feature to reduce the risk of electrical shock, this plug is intended to fit in a polarized outlet only one way. If the plug does not fit fully in the outlet, reverse the plug. If it still does not fit, contact a qualified electrician. Do not attempt to defeat this safety feature.



SAFETY WARNING

Although your appliance is easy to operate, for your safety, the below warnings must be followed:

1. Do not place the appliance near a heat source.
2. Never leave the appliance unattended while connected to the electrical outlet.
3. To avoid any accidental burns, never put a hand over a steam vent or cover when the appliance is in operation. Always use lid handle.
4. Use the appliance on a stable work surface away from water.
5. Do not unplug the socket by pulling on the supply cord.
6. The appliance must be unplugged:
 - A. Before either filling or emptying
 - B. Before any cleaning or maintenance
 - C. After use
 - D. If it appears to be faulty

THIS PRODUCT IS INTENDED FOR HOUSEHOLD USE ONLY.

LIST OF MAIN PARTS

- | | |
|--------------------------|-------------------------|
| 1. Steel Top | 9. Water Container |
| 2. Top Cover | 10. Side Panel |
| 3. Funnel | 11. LCD Timer and Clock |
| 4. Filter | 12. Control Buttons |
| 5. Funnel Support | 13. Carafe Lid |
| 6. Light | 14. Glass Carafe |
| 7. Steel Front | 15. Lid Release |
| 8. Water Level Indicator | 16. Carafe Handle |

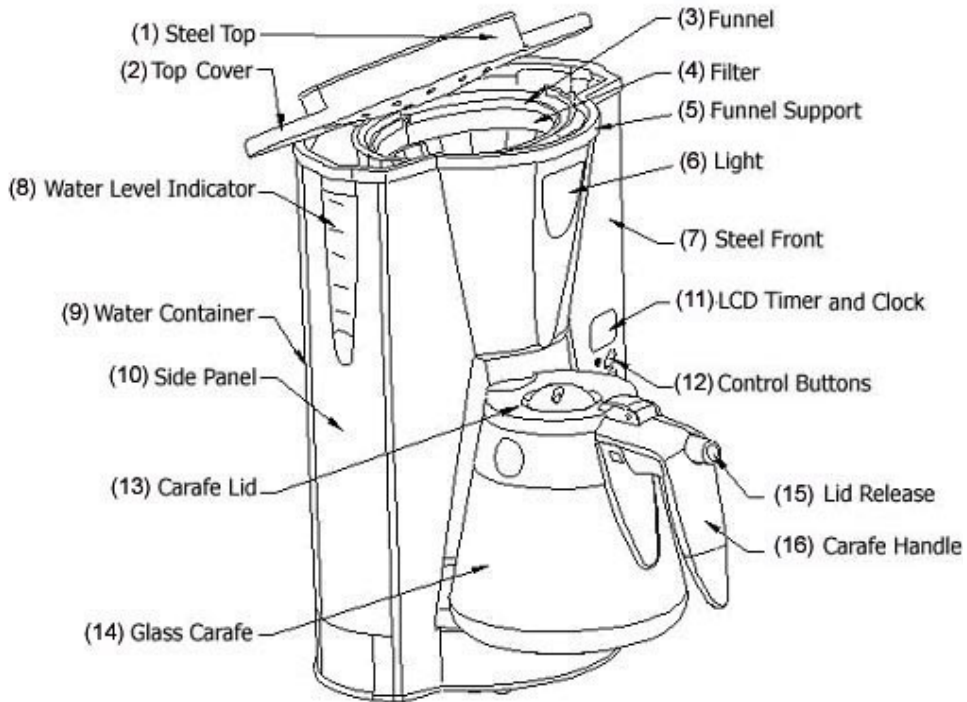

TECHNICAL SPECIFICATIONS:

Model Number	XQ-698T
Input Voltage	120 Volt AC
Nominal power	1050 Watt
Capacity	10 cups of coffee
Volume	50 fl. oz.

CONTENTS OF PACKAGING

- Coffee Maker
- Measuring Spoon
- Permanent Filter
- Glass Carafe
- Instruction Manual

If any of the above items are missing, please contact our service department at 1-888-367-7373 (<http://wwwk.wk-usa.com>) for replacement.

BEFORE THE FIRST USE

Before making your first pot of coffee, we recommend operating the coffee maker once or twice with water only, without coffee grounds to remove any possible dust.

OPERATION

1. Open the top cover, use the glass coffee carafe to pour in the desired quantity of water into the water container. The water level indicator shows how much water you are filling into the container.
2. Place glass coffee carafe directly underneath the brewing spout, and making sure that the lid is secured to the pot.
3. Add coffee grounds to the permanent filter. (Refer to the recommendations on the coffee grounds packaging)
4. Place the permanent filter into the funnel support.
5. Close the top cover.
6. **To Set the Time/Timer**
 - A. Press **PROG** button once to set TIME
⇒ Press the **HR** and **MIN** buttons to set the time desired
 - B. Press **PROG** button twice to set AUTO ON function
⇒ Press the **HR** and **MIN** buttons to set the time desired
 - C. Press **PROG** button three times to lock timer
7. **To operate coffee maker**
 - A. For Immediate Brewing.
⇒ Press **ON/OFF** button once to start brewing, the RUN red indicator light will turn on.
 - B. For Program Use.
⇒ Press **ON/OFF** button twice to set the AUTO function. The green indicator light will turn on. The coffee maker will automatically start to brew at the set time. (As noted above in instruction 6 B)
 - C. To Turn Off
⇒ Press **ON/OFF** button the third time to turn the coffee maker off.
8. After the brewing process is complete and the water container is empty, the heating plate will stay on for one hour to keep the coffee warm.

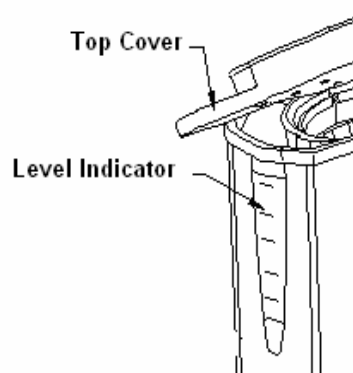
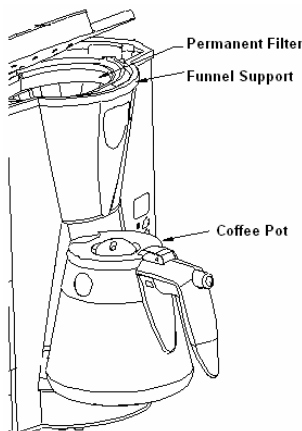



MAINTENANCE

CAUTION:

Always be sure that the appliance is switched OFF before cleaning or attempting to store the item.

CLEANING

1. Always unplug the coffee maker before cleaning.
2. Remove the permanent filter and discard used coffee ground.
3. The permanent filter, glass carafe and lid, and removable funnel should be washed in warm soapy water. Rinse before replacing on coffee maker.
4. Do not place permanent filter, removable funnel or carafe in dishwasher.
5. Wipe outside with soft dry cloth when coffee maker is wet, never use scouring agents or metal polish this could damage the steel finish.
6. Never use a dishwasher to clean the glass carafe.
7. The appliance must not be immersed in water for cleaning.

PERMANENT FILTER

Please handle the permanent filter with care as the nylon mesh is very delicate. Do not scrub the filter mesh but wipe it gently with a soft cloth or sponge.

If the filter should get worn out due to normal use over time the following can be done

- A. Replacement permanent filters are available from our service center. You can purchase a replacement permanent filter on the internet (<http://www.wk-usa.com>) or mail the attached order form included in the instruction manual along with your money order to our Service Center.
- B. This coffee maker can be used with normal paper coffee filters. Please use a cone shaped filter with a height of 4". Remove the permanent filter and place the paper coffee filter in the filter funnel.

STORING

Allow the appliance to cool completely before storing. Store the appliance in a dry location. Do not place any heavy items on top of appliance during storage as this may result in possible damage of appliance.

Store the cord in a clean, dry location away from metal objects. Always check the plug before use to assure metal items have not become attached.

SERVICE CENTER

If you have any question in regards to the operation of this appliance or are in need of a spare part please contact our service center at:

Wachsmuth & Krogmann, Inc.
Tel: 1-888-367-7373
(Business hours Mon-Fri 9:00am - 4:00pm CT)
Website: <http://www.wk-usa.com>

ENVIRONMENTAL PROTECTION

If the appliance should no longer work at all, please make sure that it is disposed in an environmentally friendly way, by handing it into a public collection point. Please do not put it with your household waste.



LIMITED WARRANTY

Thank you for purchasing a top quality **Crofton** product. This **10 Cup Coffee Maker item #6537** was tested and meets our stringent quality standards. This product is warranted to be free from manufacturing defects in original materials, including original parts, and workmanship until **February 15, 2006 or 1 year with proof of purchase.**

The warranty is void if the defect is due to accidental damage, misuse, abuse, neglect, improper repair or alteration by unauthorized persons or failure to follow operation instructions provided with the product. This warranty does not apply to commercial use.

The warranty is non-transferable and applies only to the original purchase and does not extend to subsequent owners of the product. Liability under this warranty is limited to repair, replacement or refund. In no event shall liability exceed the purchase price paid by the purchaser of the product. Under no circumstances shall there be liability for any loss, direct, indirect, incidental, special or consequential damage arising out of in connection with use of this product. This warranty is valid only in the United States of America. This Warranty gives you specific legal rights. However you may have other rights that vary from state to state. Some states do not allow limitation on implied warranties or exclusion of consequential damages therefore these restrictions may not apply to you.

In case you find the product to be defective please send it within the warranty period to our service center. To avoid transport damages please send the product in the original packaging. In return you will either receive your repaired item, a new product or a refund. Please fill out the Warranty Card and send it together with the product and purchase receipt

To arrange pick-up of the defective item please call our service center:

Wachsmuth & Krogmann Inc.

Tel: 1-888-367-7373 (Business hours Mon-Fri 9:00am-4:00 pm CT)

Website: <http://www.wk-usa.com>

**123 Sivert Court,
Bensenville, IL 60106,
USA**

WARRANTY INFORMATION

WARRANTY CARD



Crofton 10 Cup Coffee Maker, item #6537, model # XQ-698T

In case you find this product to be defective please send it within the warranty period to our service center. To avoid transport damages please send the product in the original packaging. In return you will receive your repaired item, a new product or a refund.

Please fill in your details below and send it together with the product and purchase receipt. Please read the Limited Warranty conditions mentioned in this instruction manual.

Customer Name	
Street	
City	
State	
ZIP Code	
Purchase Date	
Description of Defect :	

To arrange pick-up of the defective item please call our service center:

Wachsmuth & Krogmann Inc.
Tel: 1-888-367-7373 (Business hours Mon-Fri 9:00am-4:00 pm CT)
Website: <http://www.wk-usa.com>
123 Sivert Court,
Bensenville, IL 60106,
USA

PLEASE DETACH THIS SECTION AND RETURN IT WITH YOUR PRODUCT



WARRANTY CARD

ORDER FORM

FOR REPLACEMENT PERMANENT COFFEE FILTER

Price per filter (includes shipping and handling \$ 10.00)

Please send a **MONEY ORDER** only (no cash or personal checks) ,
payable to Wachsmuth & Krogmann Inc. to the following address:

Wachsmuth & Krogmann Inc,
123 Sivert Court
Bensenville, IL 60106

Kindly fill in your information below and send together with your
Money Order

Name

Street

City

State

ZIP

Date

Quantity of filters

_____ filter @ \$

Total amount

_____ \$

