



701 S Ridge Avenue, Troy, OH 45374
1-888-4HOBART • www.hobartcorp.com

FastRack WAREWASHING SYSTEMS

HOBART

STANDARD FEATURES

- Top mounted controls
- Stainless steel anti-clogging wash arms
- Stainless steel front panel
- Stainless steel frame and legs
- Automatic fill
- Scrap screen and bucket system
- Stainless steel pump and impeller
- Pump intake screen
- Door actuated drain closure
- Door interlock switch in all doors
- Vent fan control
- Convertible hot water or low temp final rinse

DIRECTION OF OPERATION

- Clockwise, Doors In (L-R)
- Clockwise, Doors Out (R-L)
- Counter-Clockwise, Doors In (R-L)
- Counter-Clockwise, Doors Out (L-R)

VOLTAGE

- 208/60/3 – Electric Heat
- 240/60/3 – Electric Heat
- 208-240/60/3 – Steam Heat or Gas Heat
- 480/60/3 with 20 V. Pilot Circuit

MODEL

- FastRack Dishwasher

OPTIONS AND ACCESSORIES AT EXTRA COST

- Single point electrical connection
- 6" higher than standard chamber
- Conveyor dwell
- Blower dryer
- Prewash on curve (90° or 120°)
- Stainless steel vent hoods
- Extra push button stations
- Tray loops
- Hose reel
- Food waste trough
- Glass and cup rack shelf
- Empty rack storage shelf
- Straight or curved hanging shelves
- Disposer or pulper system

Specifications, Details and Dimensions on Inside and Back.

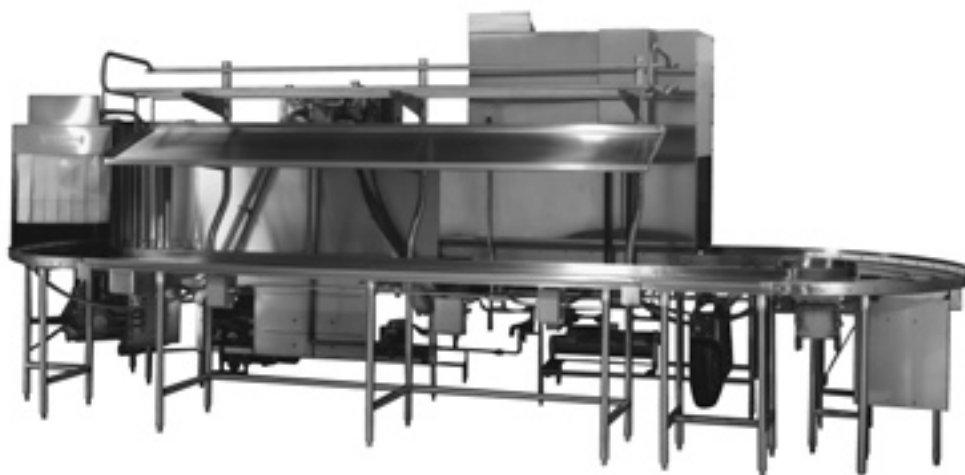

FastRack WAREWASHING SYSTEMS

FastRack WAREWASHING SYSTEMS

HOBART

701 S Ridge Avenue, Troy, OH 45374
1-888-4HOBART • www.hobartcorp.com

SPECIFICATIONS:

■ **DESIGN:** Fully automatic rack transport warewashing system utilizing any Hobart C-Line-A dishwasher or combination thereof. Design incorporates tables and rack transport system providing continuous closed-circuit operation.

■ **OPERATION:** Direction of operation may be specified either clockwise or counterclockwise determined by facing doors on C-Line machine. Inspection doors on dishmachine may be specified to face either in or out.

■ **CONSTRUCTION:** As Applicable:

Dishwasher: Any Hobart C-Line-A Dishwasher or combination thereof, selected according to production requirements. Use portion of separate specifications for C-Line-A model(s) selected. FastRack dishwasher is standard with stainless steel front panel, frame, legs & feet.

Tables: Table surface is #14 gauge stainless steel with structural cross supports. Table sections are designed with positive alignment and sealing bolted table joint connections. All "H" frames and other supporting members of 1 $\frac{5}{8}$ " diameter stainless steel tubing with stainless steel adjustable feet. Inside width of tabling – 22 $\frac{1}{4}$ ". Radius to outside of curved sections – 36". Loading section of table incorporates a 1 $\frac{1}{4}$ " high rack rest. Rack is disengaged from transport chain when placed on lip, permitting stationary loading.

■ PREWASH

Straightaway Unit: RS-22A or PW-36A prewash unit in straightaway to be specified as part of companion C-Line-A dishwasher. Refer to individual machine specifications.

On Curve: RS type prewash unit mounted in 90° or 120° hooded curved section of soiled dish table. (PW-36A prewash available in straightaway only.) Recirculating prewash with a stainless steel spray arm above with special jets designed to effectively prewash all type of tableware. Spray arm easily removed without use of tools. Integral pump, motor and drain control mounted externally on end of tank below table level. Large, removable, perforated stainless steel strainer screens sloped downward towards a deep perforated stainless steel scrap basket. Basket and screens removable at front of prewash. The scrap basket can be removed and emptied without shutting machine down. Prewash tank filled and replenished with overflow water from companion machine. No fill valve required.

■ **MOTORS:** Refer to individual Hobart C-Line model specifications.

■ **CONTROLS:** A stainless steel control center with power "on/off" and "start/stop" switches is mounted on top of machine. Machine control circuitry components will be operated from a 120 volt control circuit transformer. Electrical components are completely wired with 105°C,

600V thermoplastic insulated wire with stranded conductors routed through Listed electrical conduit or covered wireway built into the front of the machine above tank water level. Extra push button station(s) may be specified for other locations at extra cost.

■ **FRC MODEL RACK TRANSPORT SYSTEM:** Racks are delivered through dishwashing machine by means of 8,500 lb. tensile strength stainless steel endless chain with oval driving lugs and stainless steel rollers. The drive system transports racks without permanent attachment, permitting instant engagement and disengagement of racks for cleaning, loading, substitution of different racks, etc.

■ **TRANSPORT CHAIN DRIVE:** ½ H.P. ball bearing motor drives a speed reducer. Supplied in same electrical specs as dishwasher. Speed reducer power train is lubricated and cooled by an oil bath. A friction drive clutch installed in low speed shaft of speed reducer and directly connected to the drive sprocket shaft. Motor has built-in overload protection with manual reset.

■ **DRAIN CONNECTION:** Single 2" female connection for dishmachine. May be specified at either clean or soiled dish end. Separate female drain connection for disposer(s) and waste system.

■ **BUILDING HOT WATER CONNECTION:** Single 1" pipe female connection. (It is recommended that the building water temperature be 140°F.)

■ **STEAM CONNECTION:** If steam booster is specified, single 1 $\frac{1}{2}$ " female connection for steam injector(s) or steam coil(s) and steam booster.

■ **ELECTRICAL CONNECTION:** Single electrical connection for all motors and operating controls. Separate electrical connections required for electric tank heat, electric booster, electric blower dryer, disposer and waste system in front trough.

■ **RACKS:** Racks are not furnished as standard equipment. A study of customer requirements must be made to determine the number and type of racks required. Hobart racks are recommended, however, most plastic racks available from various rack suppliers with Hobart indexing could be used on the FRC system. For further information, see Warewashing Rack specification sheet Form F-7861.

■ **FILL:** Fill water line is equipped with vacuum breaker on downstream side of electrically operated solenoid valve in common piping system, for automatic maintenance of tank level. Fill is interrupted whenever a door is opened.

■ OPTIONAL EQUIPMENT AT EXTRA COST: WASH TANK HEATING

ELECTRIC: Electric incoloy sheathed immersion heaters removable from inside tank. Tank water temperature is controlled by solid-state thermostat with positive low-water protection and magnetic contactor. (Disconnect switches not furnished.) Heating elements



701 S Ridge Avenue, Troy, OH 45374
1-888-4HOBART • www.hobartcorp.com

FastRack WAREWASHING SYSTEMS

are additionally protected by a high limit device mounted on the surface of the element.

STEAM: One-inch stainless steel steam injectors or stainless steel steam coils (for contaminated steam). Tank water temperature controlled by solid-state thermostat with positive low-water protection. Steam supplied to machine through high temperature steam solenoid valve and line strainer. Each tank supplied through common steam connection.

GAS: Regulated power immersion tube gas burner system. Tank water temperature is controlled by solid-state thermostat and a blower with a centrifugal switch. Positive low water protection is provided. Immersion tube is additionally protected by a high limit device mounted on the surface of the tube. A solid-state ignitor board controls the gas valve and provides flame ignition for each tank. A transformer steps the control circuit voltage down from 120 volts to 24 volts to power the ignitor board and gas valve.

For natural gas, gas pressure to burner (customer connection) not to exceed 7" W.C.

For LP gas, gas pressure to burner (customer connection) not to exceed 11" W.C.

If gas pressure is higher than 7" W.C. natural or 11" W.C. LP, a pressure regulating valve must be supplied (by others) in the gas line to the dishwasher.

- **FINAL RINSE WATER BOOSTER HEATER:** A steam booster, electric booster or gas booster heater may be mounted under the clean dish table or freestanding on the floor in center of the dish tables.

Steam: A four-pass straight tube heat exchanger having removable headers. Equipped with solenoid valve and thermostatic control wired in flexible liquid-tight conduit. Bucket type steam trap, pressure relief valves for both water and steam, water pressure reducing valve and pressure gauge for outlet water. Maximum operating steam pressure— 50 p.s.i. For steam pressure below 20 p.s.i., consult Hobart steam booster sizing chart for proper size. Booster hot water outlet connected to fill and final rinse.

Electric & Gas: Hobart electric and gas boosters are generally mounted under clean dish table, and hot water outlet is connected to fill and final rinse.

For proper gas ventilation, see the National Fuel Gas Code and Hobart Installation Manual.

- **FOODWASTE REMOVAL:** The FastRack system may be equipped with a Hobart Food Waste Disposer or a Hobart Waste Equipment System.

FOOD WASTE DISPOSER AND TROUGH - LOADING SECTION – when specified:

Disposer: Specify Hobart food waste disposer according to size required. Your Hobart Equipment Dealer or Hobart Representative can help with sizing. Disposer supplied with magnetic starter and push button station,

having NEMA 12 enclosures, also solenoid valve, vacuum breaker and trough flushing nozzle(s). These components factory mounted, wired and plumbed as applicable. Control station for disposer conveniently located.

Food Waste Trough: 10", 12" or 16" (inside width) on front of straight soiled dish table, external of table. Trough lengths start at 4 feet (in 6" increments). Silver saver in trough, with cover over food waste disposer opening. Height of trough permits locking of trays under the 1¼" table lip specified at the loading section.

Tubular, sliding tray loops in (3) various sizes, may be specified from front-mounted trough. Number of tray loops determined by trough length.

Waste Equipment System: A food waste trough 10", 12" or 16" (inside width) with or without double skatewheels, may be connected to a Hobart Waste Equipment System and should be sized by your local Hobart Representative. Trough lengths start at 4 feet (in 6" increments).

■ **OPTIONAL SHELVES AND TABLE ACCESSORIES**

GLASS AND CUP RACK ADJUSTABLE SLANT

OVERSHELF: Constructed of #14 gauge stainless steel, turned up on back and both ends, with depressed front drain gutter and ¾" drain tube. Adjustable three ways – height, angle of tilt or slant toward operator and front to back. Supported by extensions of stainless steel "H" frame. Optional length from 4 feet to 9 feet (in 1 foot increments).

EMPTY RACK STORAGE SHELF: Flat, constructed of stainless steel tubing, with tubular back and ends. Mounts above Glass and Cup Rack Overshelf on same extensions of "H" frame. Adjustable height, and front to back with Cup and Glass Rack Overshelf. Optional length same as slant shelf.

OVERHEAD BOX SHELF – CLEAN DISH AREA:

Constructed of #14 gauge stainless steel, turned up on back and both ends, down on front. Mounted on stainless steel tube extensions of "H" frame, usually on clean end of tabling (straight or curved). Width 14", optional length from 3 feet to 7 feet (in 1 foot increments).

TRAY LOOPS – at soiled dish area:

Tray Loops: Three sizes are available; 16" x 20", 21" x 23" & 23" x 32" Sliding Loops are used on units with a disposer or waste equipment trough mounted on front edge of table. Tray loop quantity is optional.

- **HANGING SHELF:** Accessory for clean dish table (straight or curved), to facilitate unloading and sorting. Supported at top by rolled edge which hooks onto table edge and diagonal braces. 12" width, optional straight length from 3 feet to 8 feet (1 foot increments). Optional curved shelf 45°, 90° & 120°.

NOTE: All tables and accessories conform to NSF Standard No. 2.

FastRack WAREWASHING SYSTEMS

HOBART701 S Ridge Avenue, Troy, OH 45374
1-888-4HOBART • www.hobartcorp.com

SPECIFICATIONS (Continued):

■ **HOSE AND REEL:** (Optional) A spring loaded self coiling hose reel with 40 feet of high pressure hose with quick opening valve spray nozzle, conveniently mounted under table, used for table clean up or scraping dishes at soiled table section.

■ **BLOWER-DRYER (Optional Equipment)**

DESIGN: To promote rapid drying of tableware and trays by forced circulation of high velocity heated air through the unloading section of Hobart FastRack automatic dishwashing system. Unit is built in straight section only. Blower-dryer covers 5 foot, 6 inches length of straight section to provide adequate drying area.

Heavy-duty squirrel cage type industrial fan draws room air through two 22" x 21" steam heated finned-type heat exchangers and large area ducting. (Optional electrically heated unit also available.) Heated air directed downward to drying area through rectangular orifice covering full width of conveyor. Baffles below conveyor redirect air upward within drying area.

Any object which will pass through the machine will be handled at the dryer area without necessity of readjusting blower orifice upward or downward.

CONSTRUCTION: All sheet metal construction is 16 gauge stainless steel, heliarc-welded and bolted. Large sliding inspection door provides access to dryer section at rectangular orifice area. Vent is 4" x 22" inside dimension and contains a locking type control damper. Vent stack rises at entrance end of dryer chamber for connection to dishroom exhaust stack. Motor mounted to permit "V" belt adjustment.

Stainless steel wrap-around encloses entire external component assembly, consisting of both steam coils, vent stack, motor and blower. Adds approximately 21½" to height of machine.

STEAM COILS: Two double row heavy-duty high efficiency finned tube type heat exchangers set in tandem. Copper tubes and aluminum fins with galvanized steel frame. 1½" female I.P.S. brass steam connection and ¾" I.P.S. brass condensate return connection for each coil. Steam requirements are 110 pounds per hour at 20 P.S.I. or about 4.5 boiler H.P. Maximum allowable steam pressure is 25 P.S.I.

ELECTRIC HEAT: 12 - 3500 watt Incoloy electric heaters are used for a total of 42 KW heating capacity. Thermostatic control and separate over temperature protection are standard. Electrical specifications are 208/60/3, 240/60/3, and 480/60/3.

BLOWER: Industrial fan-type with squirrel cage-type wheel. Wheel shaft supported by two heavy-duty ball bearings. Housing of welded construction throughout.

2 H.P. Blower "V" belt driven, delivering 1384 CFM at 2200 FPM velocity. Exhaust requirement is 1200 to 1400 CFM.

Motor: 2 H.P. grease packed ball bearings, splash-proof enclosure, ventilated design. Furnished only in three-phase electrical specifications of the basic C-Line-A Model in 200-240/60 and 400-480/60. Above 250 volts, the controller circuit operates on reduced voltage supplied by the transformer on the dishwasher.

■ **PREWASH TEMPERATURE CONTROL:** Control of prewash tank temperature is accomplished by adding cold water automatically through jet-type fill with suds trap and airbreak or vacuum breaker. The control components are installed on the prewash unit and consists of a thermostat, easy-open line strainer and solenoid valve. Prewash temperature control is required on units with RS or PW prewash when a Blower-Dryer is specified.

■ **AUXILIARY VENTING:** An extended hood with a 4" x 16" vent opening can be mounted on the entrance or exit end of the warewasher. If a prewash in the curve is specified, a 4" x 16" vent opening is standard equipment but can be covered if desired.

■ **VAPOR CONDENSER OPTION:** Eliminates the need of overhead watertight ducting and performs the necessary exhaust function from the dishmachine. Condenser is mounted over vent at discharge end of machine. On larger machines, two condensers may be used – one at each end. **Not recommended** where temperature of tap water exceeds 55°F. Refer to separate Condenser Spec. Sheet Form F-8102 for more complete details on condenser selection. Condenser is not a make-up air unit nor should it be used as a source of supply for make-up air.

If the optional Hobart Condenser is not specified, condensation-tight (water-tight) forced exhaust system to the outside air is necessary to carry off the humidity-laden drying air and thus maintain desirable working conditions within the dish room. Such exhaust system to be supplied by the user or general building contractor at time of installation.

■ **SPECIAL NOTE:** These specifications cover the dishwashing machine, rack transport system and over-shelving only. Supporting equipment such as soiled dish holding shelves, carts, rack dollies, silverware containers, silver sorting tables, soak sinks, self-leveling dispensers and other related equipment must be furnished by others to complete the warewashing system.

■ **SHIPMENT AND ASSEMBLY:** System shipped in sections. Installation and connection of all utilities to be supervised by a factory trained, Hobart Service Technician.

Optional features in this specification sheet are available at extra cost.



701 S Ridge Avenue, Troy, OH 45374
1-888-4HOBART • www.hobartcorp.com

FastRack WAREWASHING SYSTEMS

TYPICAL LAYOUTS

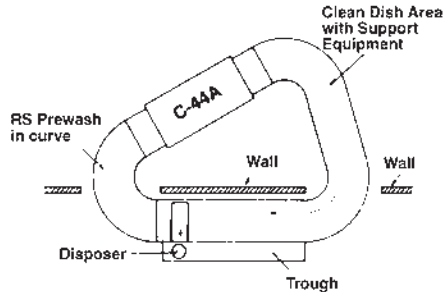

A typical thru the wall layout with triangular system isolating soiled ware from the clean ware.

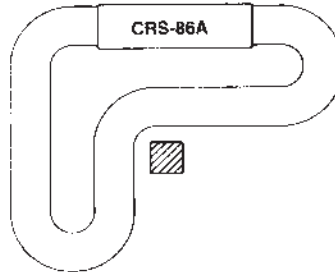

Typical L-Shaped system designed to fit around columns or other physical obstruction. Incorporates large soiled and clean dish areas. Typically supplied with two drive units.

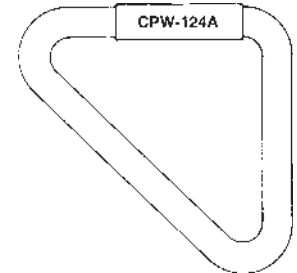

Another of the many various types of layouts that may be incorporated using a FastRack system.

FRC "A" SERIES

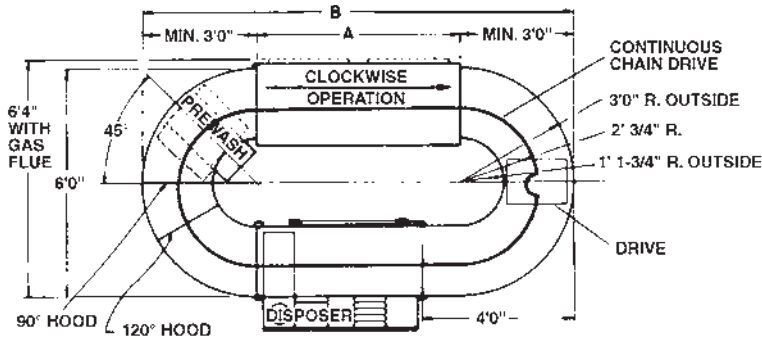

FIGURE #1 Shows an FRC-A Series System with a front mounted trough, cross trough and end-mounted disposer. Trough shown with removable sliding grid. Prewash in the curve with 90° or 120° hood with vent.

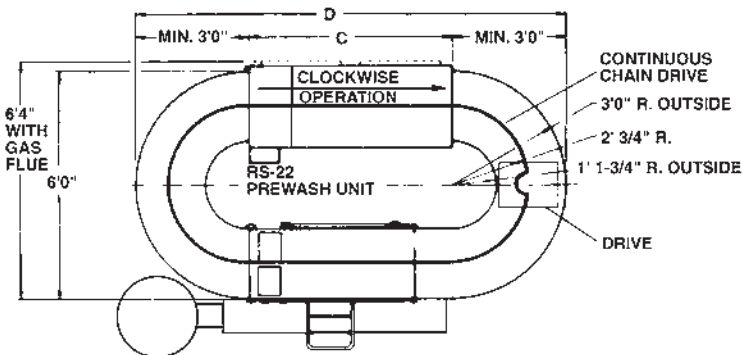
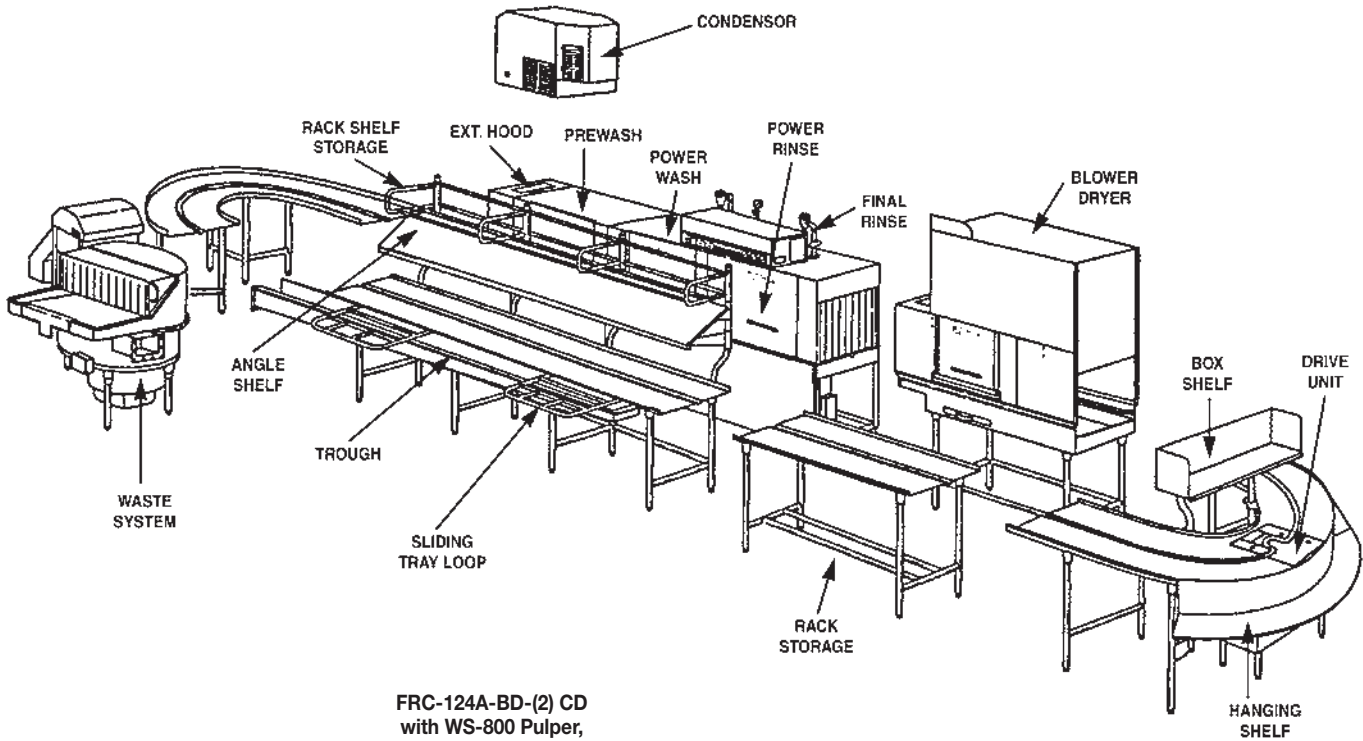

FIGURE #2 Shows an FRC-A Series System with a prewash in the straight section. Front-mounted trough, cross trough with pulper system. Trough with removable sliding tray loop.

Overall dimensions indicated on the chart below are minimums required for individual C-Line-A dishwasher models. These dimensions may be increased, if desired by adding additional lengths of straight table.

Model No.	Dim. A	Dim. B	Model No.	Dim. C	Dim. D	Model No.	Dim. C	Dim. D
C-44A	3'8"	Add "A" dimensions to that of the curved sections.	CRS-66A	5'6"	Add "A" dimensions to that of the curved sections.	CPW-80A	6'8"	Add "C" dimensions to that of the curved sections.
C-54A	4'6"		CRS-76A	6'4"		CPW-90A	7'6"	
C-64A	5'4"		CRS-86A	7'2"		CPW-100A	8'4"	
C-88A	7'4"		CRS-110A	9'2"		CPW-124A	10'4"	

BASIC FASTRACK COMPONENTS



FRC-124A-BD-(2) CD
with WS-800 Pulper,
Steam Blower Dryer &
(1) Condenser
Clockwise Doors In
(Shown Above)

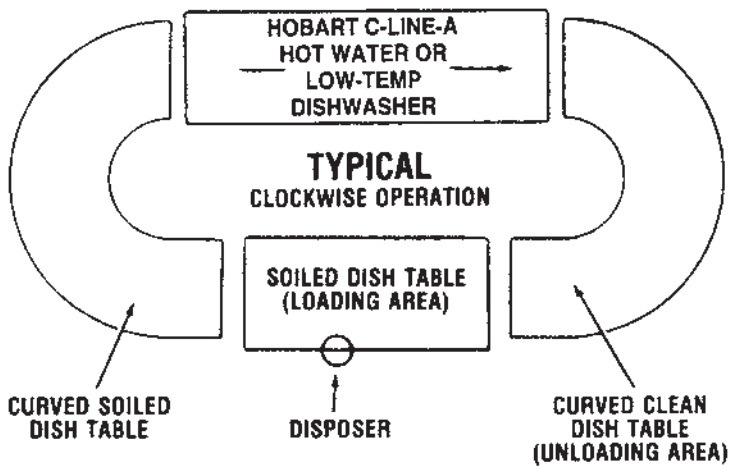

The basic components at left show a clockwise arrangement (counterclockwise may be specified) using a C-Line-A Dishwasher, curved clean dish table, straight soiled dish table with disposer in trough, and curved soiled dish table. However, FastRack Warewashing Systems are not limited to oval configurations. The drawings on the previous page, show examples of other typical arrangements, such as a triangle and L-shaped.



701 S Ridge Avenue, Troy, OH 45374
1-888-4HOBART • www.hobartcorp.com

FastRack WAREWASHING SYSTEMS

FLEXIBILITY

CUSTOM-DESIGNED TO MEET YOUR NEEDS.

Each FastRack System is custom-designed and configured to best meet your exact productivity and space requirements — oval, triangular, L-shaped, rectangular and other unique shapes.

FULL LINEUP OF C-LINE-A MODELS FROM WHICH TO CHOOSE.

Available in a full range of sizes and configurations to meet your specific warewashing needs. See our C-Line-A brochure for complete details on the most popular warewasher in the world.

BREAKDOWN AND SCRAPPING DESIGNED TO FIT.

Scrapping Troughs are available in specific lengths and widths, and can be specified with skatewheels if needed. Waste goes directly into the trough and flows to a disposer or optional waste pulping system.



In-table cross troughs available with or without drain to keep food soil out of machine.

SPACE UTILIZATION

BEST USE OF AVAILABLE SPACE. FastRack Systems offer flexibility to meet specific space constraints. They can be configured to fit in restricted and odd-shaped spaces, and/or work around obstructions. For example, tabling can be laid out to go around pillars or through walls.

You don't have to shoehorn an existing machine into a challenging space and working environment. Instead, we help design the ideal system to make a problem space a productive space. The result is improved work flow and maximum productivity to make the most efficient utilization of your dishroom space.

PREWASH SECTION MEETS YOUR SPACE NEEDS.

Curved Prewash Sections save space and are available in 90-degree and 120-degree vented chambers to best fit your space requirements. Straight-through prewash also available.

CONVEYORS SPEED WORK FLOW. Highly reliable closed-loop conveyors are a proven design, configured to meet any operational need. Conveyors are integrated into the total design to maximize work flow.

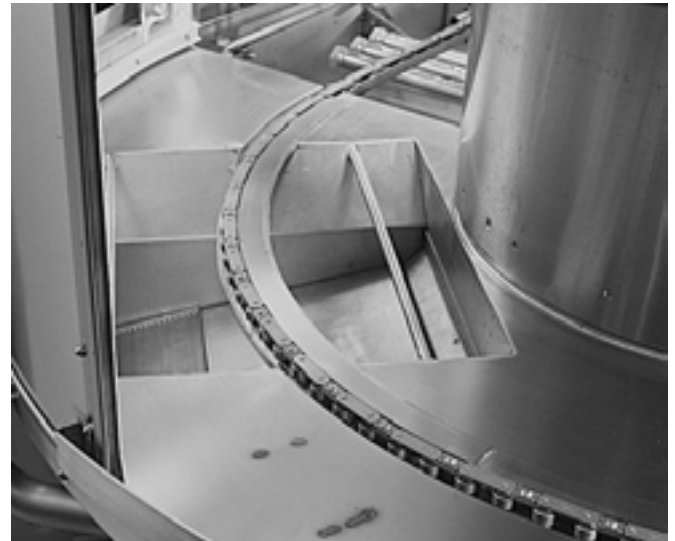

Prewash sections can be straight or curved.

CHOICE OF SHELVING OPTIONS ADDS CONVENIENCE.

Single or double overhead Slant Shelves are available in specific lengths for glass and cup racks and are adjustable for height, angle and tilt. Box Overhead Shelves are also available.

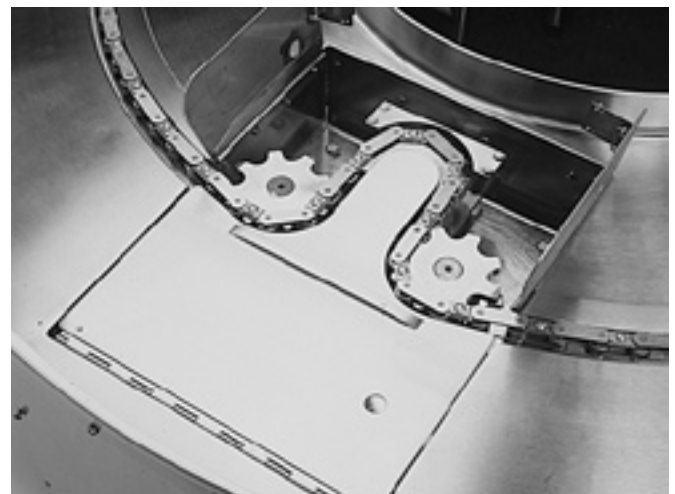

Conveyors are designed for maximum productivity.

FastRack WAREWASHING SYSTEMS



701 S Ridge Avenue, Troy, OH 45374
1-888-4HOBART • www.hobartcorp.com



Variety of storage systems helps clear working area.

Hanging Shelves can be attached to curved or straight tabling and are offered in specific lengths to add storage convenience.

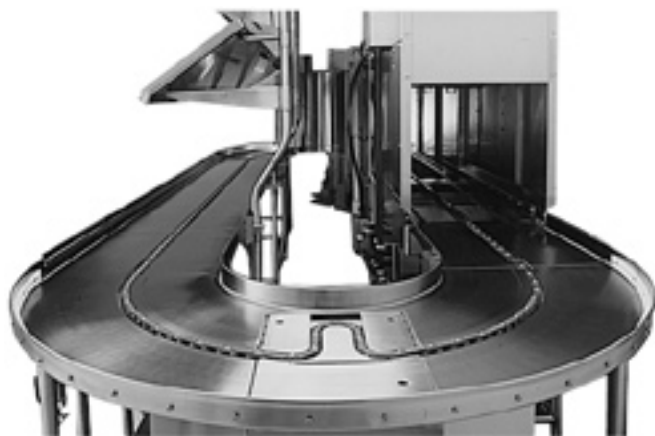

Removable racks for easy, thorough clean-up.

LABOR SAVINGS

MAXIMIZE LABOR EFFICIENCY. Versatile, flexible FastRack Systems help you reduce labor hours and plan labor requirements to meet changing needs. The system can bring the ware directly to each of the operators — no running back and forth to load racks and unload clean ware.

Result: significant time saving, reduced handling, less breakage. Plus, the load and unload sections are custom designed and configured for optimum working space to make best use of your people — no idle hands during slower periods, fewer people doing more during peak rush hours.

HIGH PRODUCTION

HIGH SPEED, HIGH VOLUME. Hobart FastRack Systems handle high volumes with production up to 367 racks per hour or 9,175 pieces of ware per hour.

RAPID DRYING PUTS WARE BACK IN SERVICE QUICKLY. Available Blower Dryer concentrates air on clean ware, not over the unloading table or employee work area. Promotes rapid drying of ware, especially trays and other plastic ware, speeds operation, reduces total ware inventory requirement.



Steam or electric blower dryers ensure fast ware drying.

OPTIONAL PULPER CUTS WASTE VOLUME UP TO 85%. Integrated Waste Equipment systems reduce handling costs while addressing environmental concerns. These Hobart systems cut foodservice waste volume up to 85 percent.

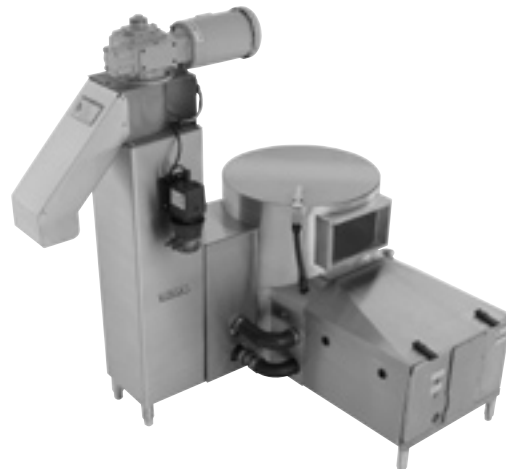

Waste Pulper cuts solid waste volume up to 85%.

As continued product improvement is a policy of Hobart, specifications are subject to change without notice.