

HP UPS R5000

User Guide

Abstract

This document includes installation, configuration, and operation information for the HP UPS R5000. This document is for the person who installs and maintains power products. HP assumes you are qualified in the servicing of high-voltage equipment and trained in recognizing hazards in products with hazardous energy levels.



Part Number: 637909-003 A
February 2013
Edition: 3

© Copyright 2011, 2013 Hewlett-Packard Development Company, L.P.

The information contained herein is subject to change without notice. The only warranties for HP products and services are set forth in the express warranty statements accompanying such products and services. Nothing herein should be construed as constituting an additional warranty. HP shall not be liable for technical or editorial errors or omissions contained herein.

Microsoft®, Windows®, Windows Vista®, and Windows Server® are U.S. registered trademarks of Microsoft Corporation.

Contents

Overview	6
UPS R5000 overview	6
Important safety information	6
Component identification	7
UPS front panel	7
UPS front panel controls	8
UPS rear panel	8
REPO port	9
ERM rear panel	10
Installation and configuration	11
Precautions	11
Preparing to install the hardware	11
Tools and materials	11
Selecting a site	12
Readying the equipment	12
Installing the mounting rails	12
Preparing the rails for integrated shipping	16
Installing the UPS	17
Connecting the battery leads	17
Attaching the UPS front bezel	18
Connecting the serial communications port	18
Connecting the USB communications port	21
Connecting the REPO port	21
Connecting the ground bonding cable	23
Connecting the network cable	23
Connecting the UPS to utility power	24
Connecting devices to the UPS	24
Connecting the UPS cord retention clips	25
Charging the UPS batteries	25
Starting power to the load	25
Configuring the UPS Network Module	25
Connecting the configuration cable	25
Launching a terminal emulation program	26
Configuring the UPS Network Module network settings	26
Accessing the web interface	27
Configuring the UPS Network Module settings	28
Installing the ERM	28
Attaching the ERM front bezel	29
Connecting the ERM to the UPS	30
Charging the ERM batteries	30
UPS operations	31
Modes of operation	31
Standby mode	31
Operate mode	31

Auto-Bypass mode	31
Configuring the UPS	32
Changing the language.....	32
Changing display functions.....	32
Verifying the REPO port connection	33
Powering down the UPS	34
Power management	35
Power Protector software	35
Maintenance	37
Removing the UPS front bezel	37
Removing the ERM front bezel.....	37
Replacing the UPS Network Module	37
Replacing the batteries.....	38
Important battery safety information	38
Battery care and storage guidelines	39
UPS battery replacement procedure	39
Replacing the UPS	41
Replacing the ERM	43
Updating the UPS firmware	43
Troubleshooting	44
Alarm troubleshooting	44
Silencing an audible alarm	46
Battery connection condition	46
Bypass is unavailable	46
General alarm condition	46
Input voltage is out of range	47
Insufficient warning of low batteries	47
Internal UPS fault condition	47
Low battery shutdowns	47
Overload condition	48
REPO condition.....	48
Site wiring condition.....	48
UPS does not provide the expected backup time	48
UPS does not start	48
UPS frequently switches between utility and battery power.....	48
UPS is in Auto-Bypass mode.....	49
UPS is on battery.....	49
UPS is on bypass.....	49
Utility power condition	49
Specifications	50
UPS physical specifications.....	50
ERM physical specifications	50
UPS input specifications	50
UPS output specifications.....	50
Power protection specifications	51
Voltage specifications	51
Output tolerance specifications.....	51
Output feature specifications	51
Battery specifications	52
Average battery runtime	52
Minimum battery runtime	52

Environmental specifications	53
REPO port specifications	53
Spares.....	54
Ordering spares.....	54
UPS spare parts list.....	54
Hardware options	54
Regulatory information	55
Safety and regulatory compliance	55
Turkey RoHS material content declaration.....	55
Ukraine RoHS material content declaration.....	55
Warranty information	55
Limited warranty	55
\$250,000 Computer Load Protection Guarantee.....	55
Pre-Failure Battery Warranty	56
Recommended duration of use	56
Electrostatic discharge	57
Preventing electrostatic discharge	57
Grounding methods to prevent electrostatic discharge.....	57
Support and other resources	58
Before you contact HP.....	58
HP contact information.....	58
Acronyms and abbreviations.....	59
Documentation feedback	60
Index.....	61

Overview

UPS R5000 overview



The HP UPS R5000 features a 3U rackmount design and offers power protection for loads up to 5000 VA/4500 W. Features include:

- 3U UPS height, 3U ERM height
- ERM technology that uses advanced battery management to increase battery service life, optimize recharge time, and provide a warning before the end of useful battery life
- Extended runtime with up to four ERMs per UPS
- Easily replaceable battery modules that simplify maintenance
- Emergency shutdown control through the REPO port
- HP UPS Network Module network connectivity with monitoring and control
- Firmware that is service upgradeable through the standard DB-9 communication port
- Backed by worldwide agency approvals

To benefit from the latest product enhancements, update to the latest versions of UPS firmware and software.

NOTE: To download the latest versions of UPS firmware and software, see the HP website (<http://www.hp.com/go/rackandpower>).

Important safety information

-
-  **WARNING:** To reduce the risk of fire, only connect unit input to a circuit provided with branch circuit overcurrent protection for 40 A rating in accordance with the National Electric Code, ANSI/NFPA 70.
Disconnect the charging source prior to connecting or disconnecting battery terminals.
Determine if the battery is inadvertently grounded. If inadvertently grounded, remove the source from the ground.
-
-  **WARNING:** Contact with any part of a grounded battery can result in electrical shock. Shock risk is reduced if grounds are removed during installation and maintenance.
-

Component identification

UPS front panel

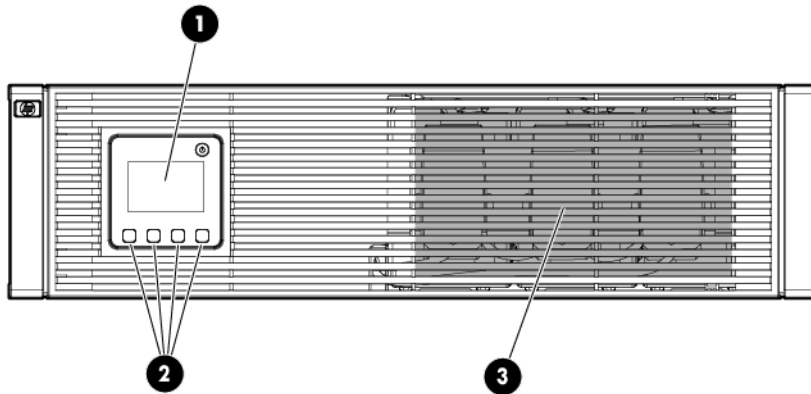

Item	Description
1	LCD display
2	Control buttons
3	Battery compartment

UPS front panel controls

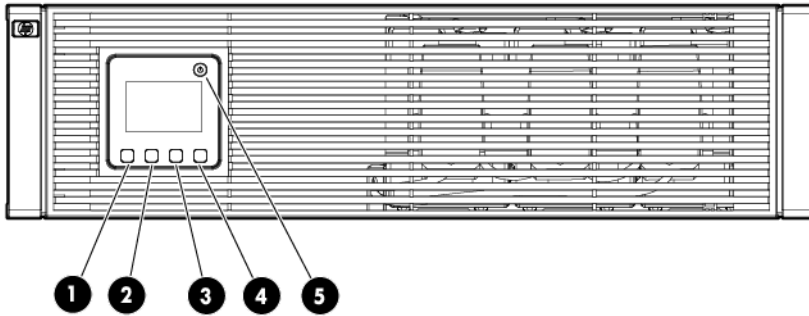

Item	Component	Description
1	ESC button	Cancel/return to the previous menu
2	Up arrow	Scroll through the menu structure
3	Down arrow	Scroll through the menu structure
4	Enter/select button	Select an option
5	Power on/off button	<ul style="list-style-type: none"> Green—operating Flashing green—on/off/standby

UPS rear panel

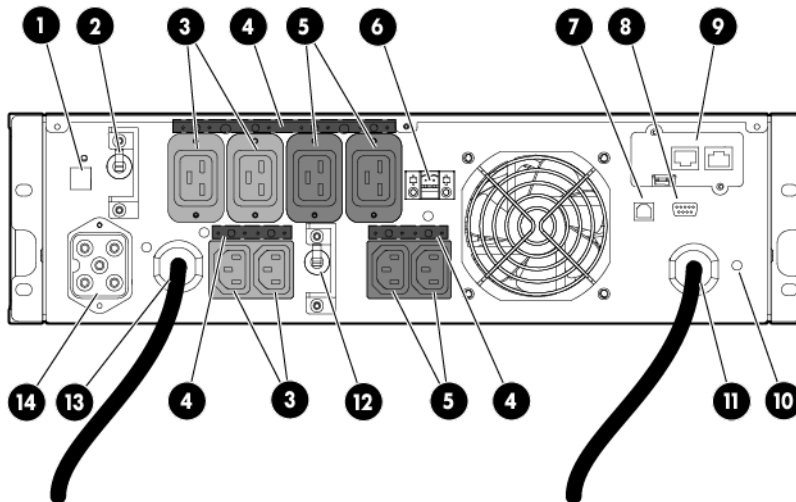

Item	Description
1	ERM connector for the small plug on the split ERM cable
2	Load segment 1 circuit breaker (controls the C19 and C13 receptacles, but does not control the large output receptacle)
3	Load segment 1 (two IEC-320-C19 receptacles and two IEC-320-C13 receptacles)
4	Cord retention clip attachment locations
5	Load segment 2 (two IEC-320-C19 receptacles and two IEC-320-C13 receptacles)
6	REPO port
7	USB communications port
8	Serial communications port
9	HP UPS Network Module
10	Ground bonding screw
11	Input power line cord with NEMA L6-30 plug (NA/JPN) or IEC-309-32A plug (INTL)
12	Load segment 2 circuit breaker
13	Large output NEMA L6-30R receptacle (NA/JPN) or IEC-309-32A receptacle (INTL) associated with load segment 1
14	ERM connector for the large plug on the split ERM cable

REPO port

The UPS includes an isolated REPO port. When properly wired, the REPO feature enables the power at the UPS output receptacles to be switched off from a remote location. To use this feature, the REPO port must be connected to a remote, normally open switch (not supplied). The REPO switch is used in conjunction with a main disconnect device that removes the AC source from the input of the UPS. When the switch is closed:

- The REPO feature immediately powers down protected devices and does not utilize the orderly shutdown procedure initiated by power management software.
- The REPO feature shuts down UPS units operating under either utility or battery power.

NOTE: If the UPS was operating on battery power when the remote switch was closed, no power is available to the load devices until utility power is restored and the UPS has been manually powered up.

To restore power to the load devices after the REPO feature is activated, press the On button after the AC source is reconnected to the UPS.



IMPORTANT: Pressing and holding the On button without utility present normally initiates a battery start and the UPS assumes the load. However, if the On button is pressed and a REPO is detected, battery start is inhibited and the UPS is not able to assume the load. The electronics module fan spins and the General Alarm LED and an audible alarm are active as long as the On button is held.

To power down the entire network in the event of an emergency, the REPO ports of multiple UPS units can be connected to a single switch.

ERM rear panel

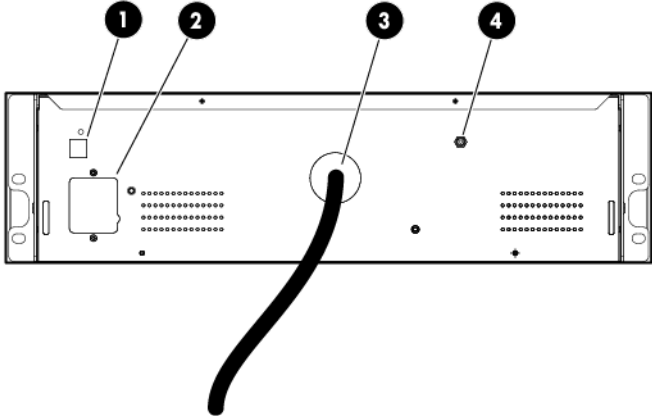

Item	Description
1	ERM input connector for the small plug on the split ERM cable of another ERM output
2	ERM input connector for the large plug on the split ERM cable of another ERM output
3	Split ERM cable with two output connectors that attach to the UPS or another ERM
4	Ground bonding screw

Installation and configuration

Precautions

Save these instructions. This document contains important safety instructions that should be followed during installation, operation, and maintenance of the UPS and batteries.



WARNING: A risk of personal injury from electric shock and hazardous energy levels exists. The installation of options and routine maintenance and service of this product must be performed by individuals who are knowledgeable about the procedures, precautions, and hazards associated with AC power products.

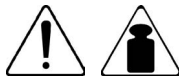

57 kg
126 lb

This symbol indicates that the UPS exceeds the recommended weight for one individual to handle safely.

WARNING: To reduce the risk of personal injury or damage to the equipment, observe local occupational health and safety requirements and guidelines for manual material handling.

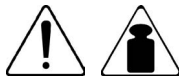

63 kg
139 lb

This symbol indicates that the ERM exceeds the recommended weight for one individual to handle safely.

WARNING: To reduce the risk of personal injury or damage to the equipment, observe local occupational health and safety requirements and guidelines for manual material handling.



WARNING: To prevent personal injury from earth conductor leakage current:

- Do not operate the UPS while disconnected from the utility power source.
- Disconnect load devices before disconnecting the UPS from the utility power source.

Preparing to install the hardware

Before installing the hardware:

1. Be sure the necessary tools and materials (on page 11) are available.
2. Select an installation site.
3. Prepare the equipment ("[Readying the equipment](#)" on page 12) for installation in the rack.

Tools and materials

The following tools are required for installation:

- Phillips screwdriver
- 10-mm hex-nut driver

The following items are supplied with the rack:

- Screws

- Hex nuts
- Cage nuts
- Cage nut-fitting tool

Selecting a site



WARNING: To prevent fire or electric shock, install the unit in a temperature- and humidity-controlled indoor environment, free of conductive contaminants.

When selecting a site, consider the following factors:

- Elevated operating ambient temperature—If the equipment is installed in a closed or multi-unit rack assembly, the operating ambient temperature of the rack environment might be greater than room ambient temperature. Install the equipment in an environment compatible with the operating temperature ("[Environmental specifications](#)" on page 53).
- Reduced air flow—In the rack, the rate of air flow required for safe operation of the equipment must not be compromised.
- Circuit overloading—Consideration should be given to the connection of the equipment to the supply circuit and the effect that overloading of the circuits might have on overcurrent protection and supply wiring. Appropriate consideration of equipment nameplate ratings should be used when addressing this concern.
- Reliable earthing—Reliable earthing of rack-mounted equipment should be maintained. Particular attention should be given to supply connections other than direct connections to the branch circuit, such as the use of power strips.
- Electrical requirements—All models require a dedicated (unshared) branch circuit, suitably rated for the specific UPS as stated in "Input specifications ("[UPS input specifications](#)" on page 50)" .

Readying the equipment

1. Check the battery recharge date specified on the label that is affixed to the shipping carton.



IMPORTANT: Do not use the battery if the recharge date has passed. If the date on the battery recharge date label has passed without the battery being recharged, contact an HP authorized service representative for directions.

2. Transport the packaged unit to its installation location.
3. Unpack the equipment near the rack where the unit will be assembled.



CAUTION: Always plan the rack installation so that the heaviest item is on the bottom of the rack. Install the heaviest item first, and continue to populate the rack from the bottom to the top.

Installing the mounting rails



WARNING: To reduce the risk of personal injury or damage to the equipment, be sure that:

- The leveling feet are extended to the floor.
- The full weight of the rack rests on the leveling feet.
- The stabilizing feet are attached to the rack if it is a single-rack installation.
- The racks are coupled together in multiple-rack installations.
- Only one component is extended at a time. A rack may become unstable if more than one component is extended for any reason.

NOTE: Mounting hardware for square- and round-holed racks is included in the UPS kit.

1. Loosen the wing nuts or hex nuts, and then extend the brackets to the appropriate length.

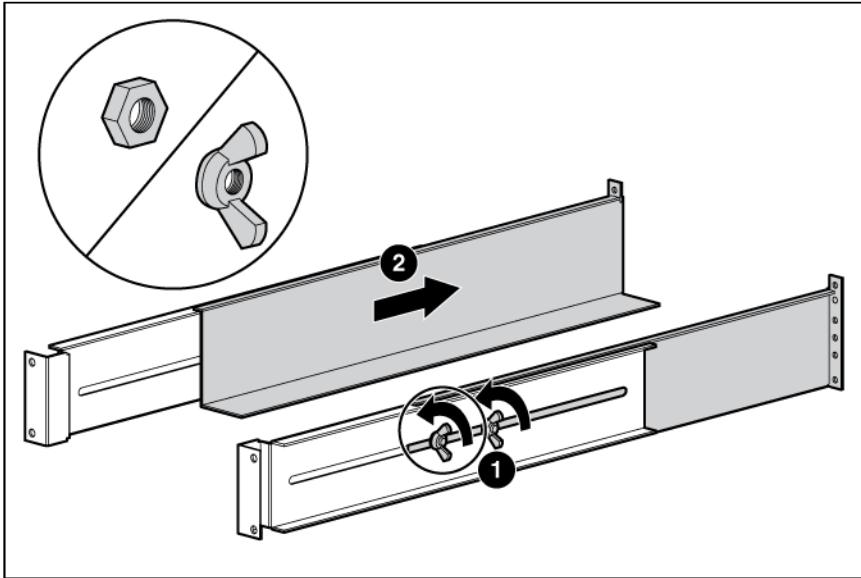

2. Insert screws through the rack into the mounting rail and the front of each mounting bracket.

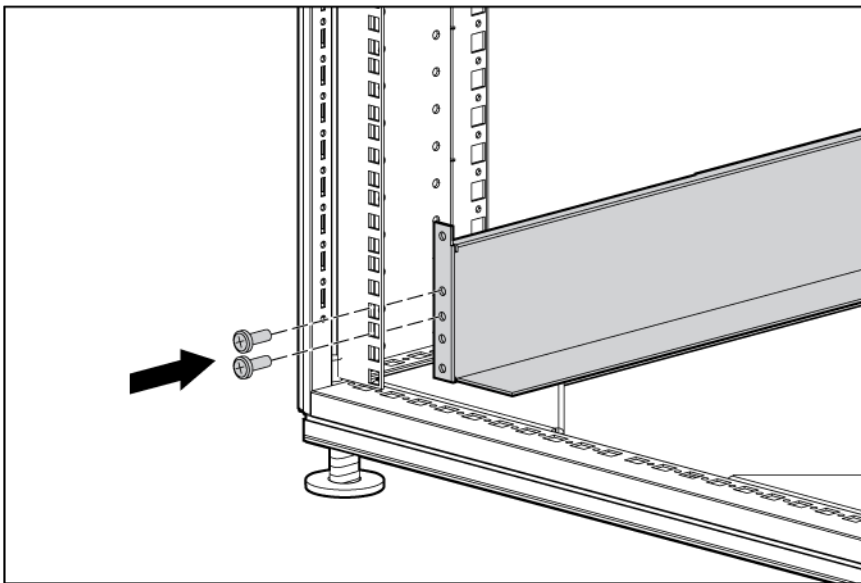

3. Install clip nuts into the rear of the rack.

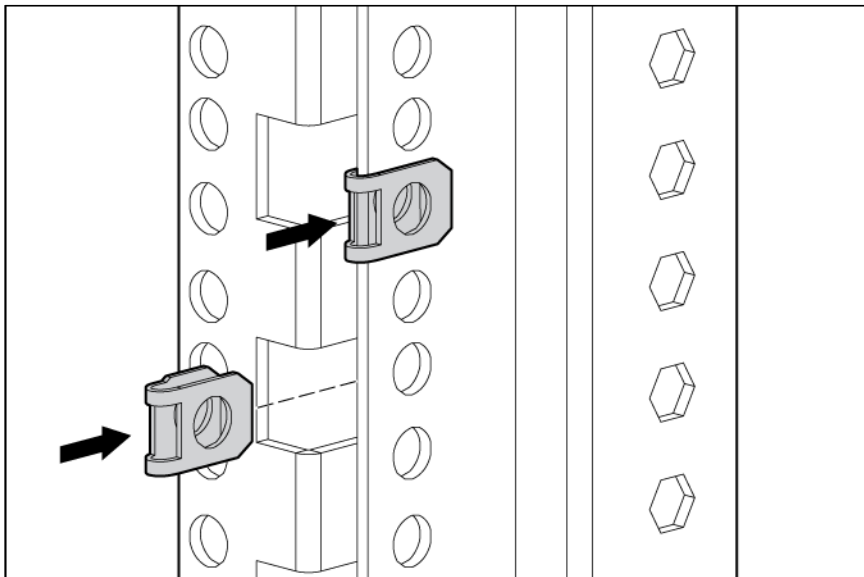

4. Insert screws through the mounting rail into the clip nuts.

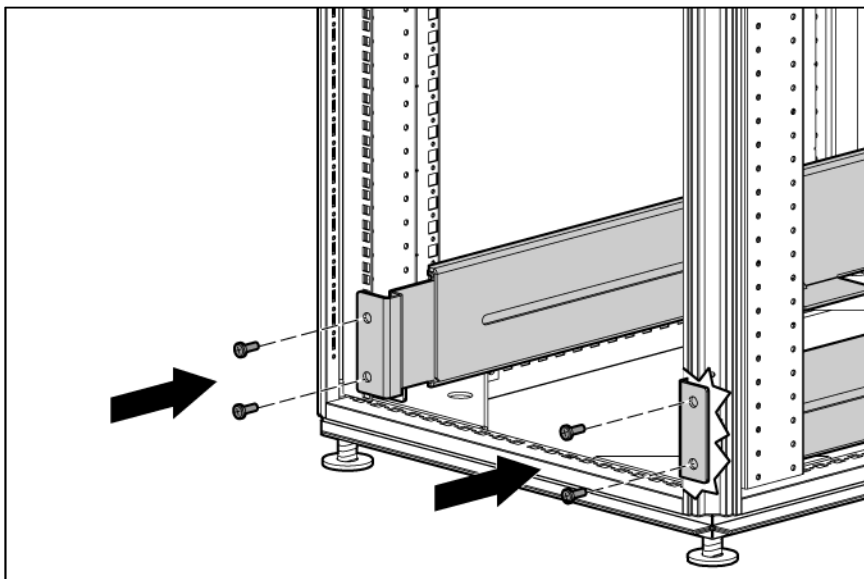

5. Install the rail reinforcement plates and tighten using hex nuts with captive washers included in the kit, instead of the nuts included with the rail.

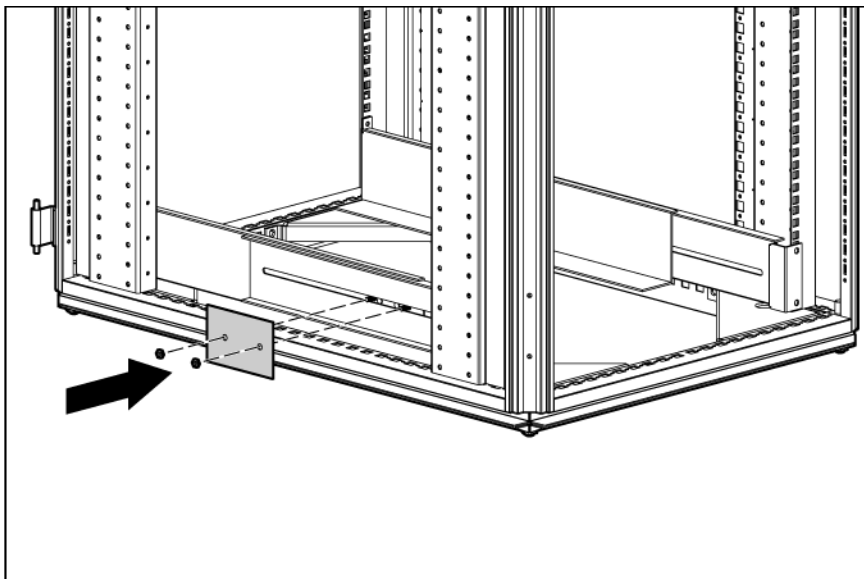

6. Tighten the wing nuts or hex nuts.

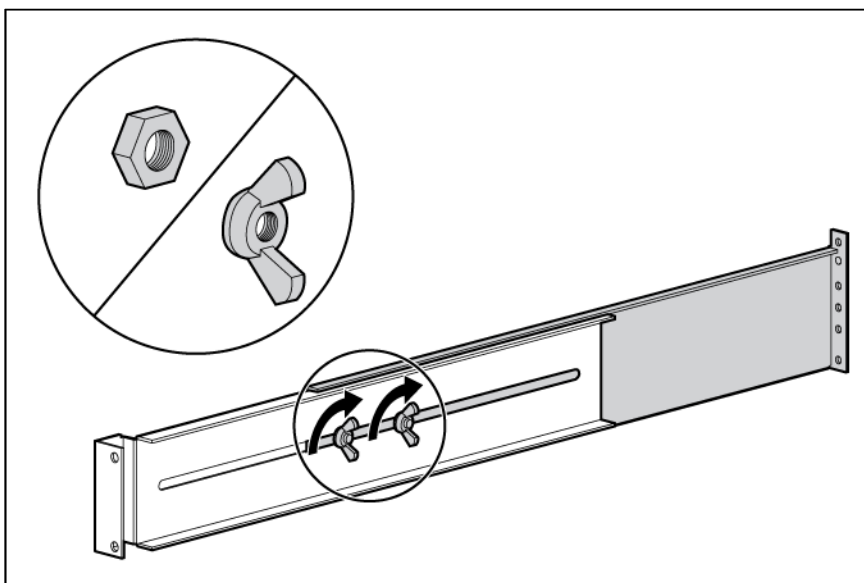

7. Install the rear mounting brackets using hex nuts. Wait until the unit is installed and the brackets are adjusted before tightening the nuts.

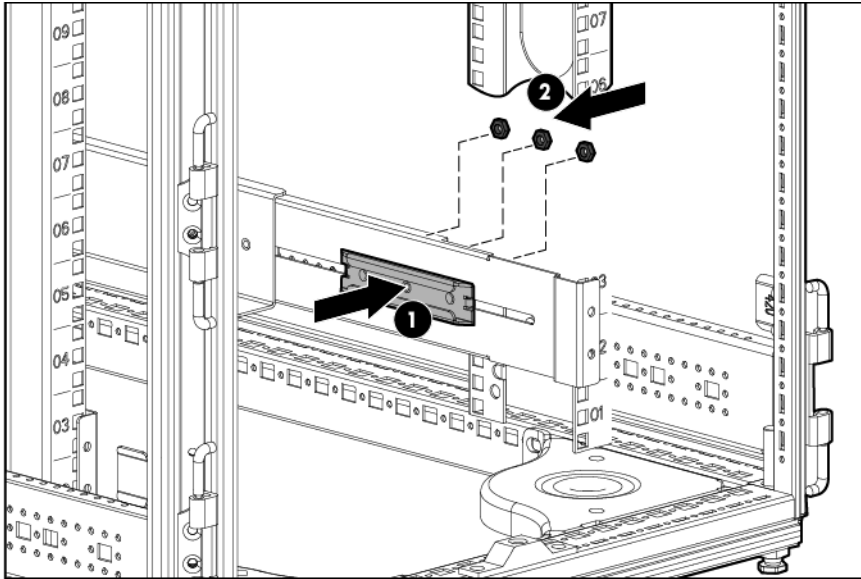

Preparing the rails for integrated shipping

If the unit is to be shipped in an HP 9000 or 10000 series rack:

1. Remove the hex nuts, flat washers, and lock washers from the mounting rail.
2. Install the rail reinforcement plates and tighten using the hex nuts with captive washers included in the kit, instead of the nuts included with the rail.
3. Install the rear mounting brackets using hex nuts. Wait until the unit is installed and the brackets are adjusted before tightening the nuts.

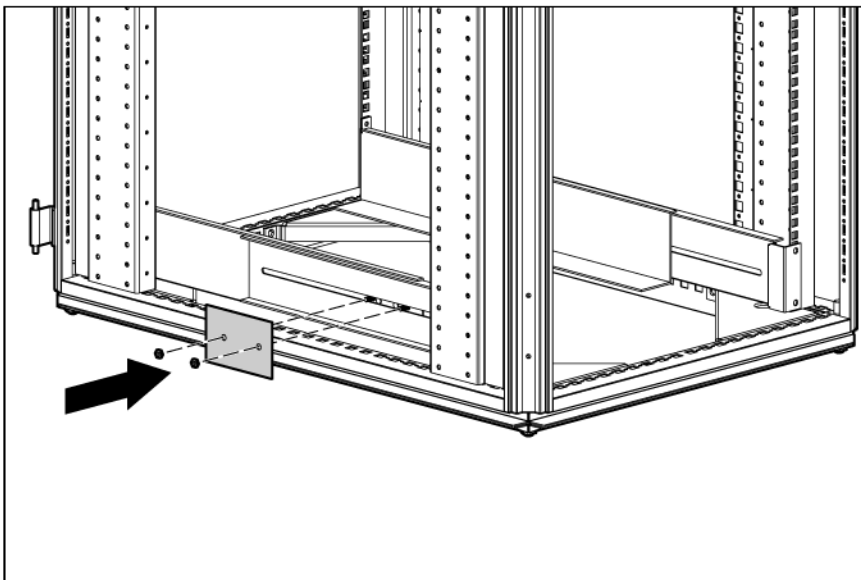

Installing the UPS

Before installing the UPS, review and observe all warnings in "Precautions (on page 11)."

⚠ WARNING: A risk of personal injury or damage to the equipment exists. Uneven loading of equipment in the rack might cause the rack to become unstable. Install the heavier components first, and then continue to populate the rack from the bottom to the top.

1. Install the mounting rails ("Installing the mounting rails" on page 12).
2. With one person on each side of the carton, lift the chassis and lower it to the floor in front of the rack.
3. Install the mounting ears on the chassis using the screws provided.

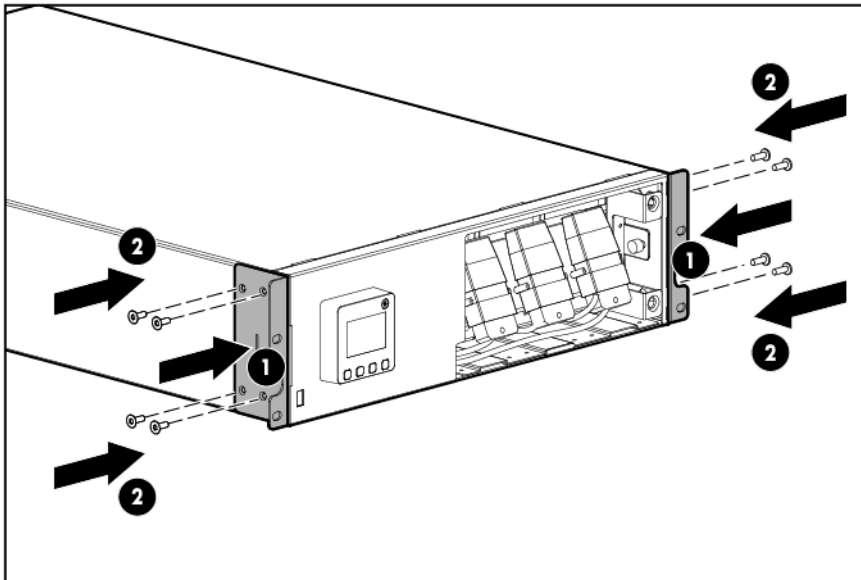

4. With one person on each side, lift the chassis to rail level and slide the chassis on the mounting rails. Be sure that the cleat brackets slide into the channels on the rear stabilization brackets.
5. Attach the chassis to the rack using the supplied screws.

Connecting the battery leads

⚠ WARNING: To prevent personal injury from electric shock or damage to the equipment, remove the battery lead labels before connecting the battery leads.

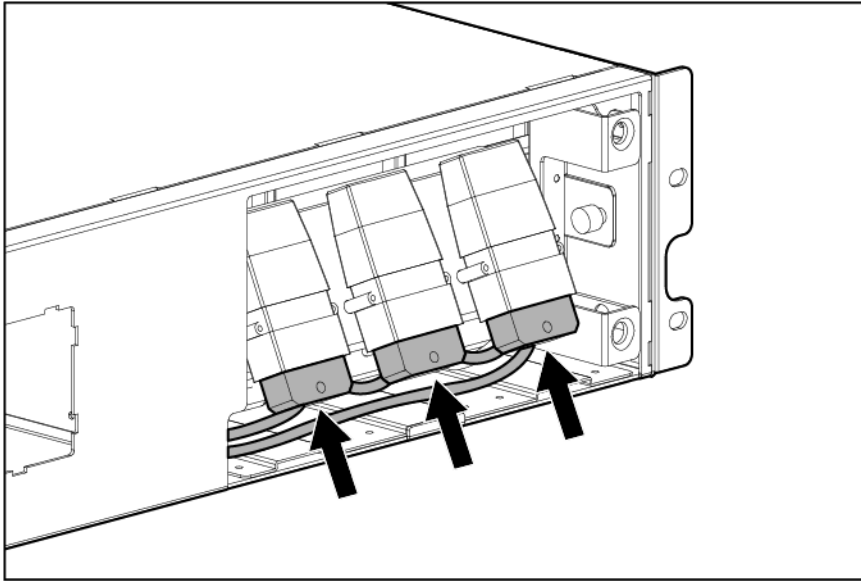

Attaching the UPS front bezel

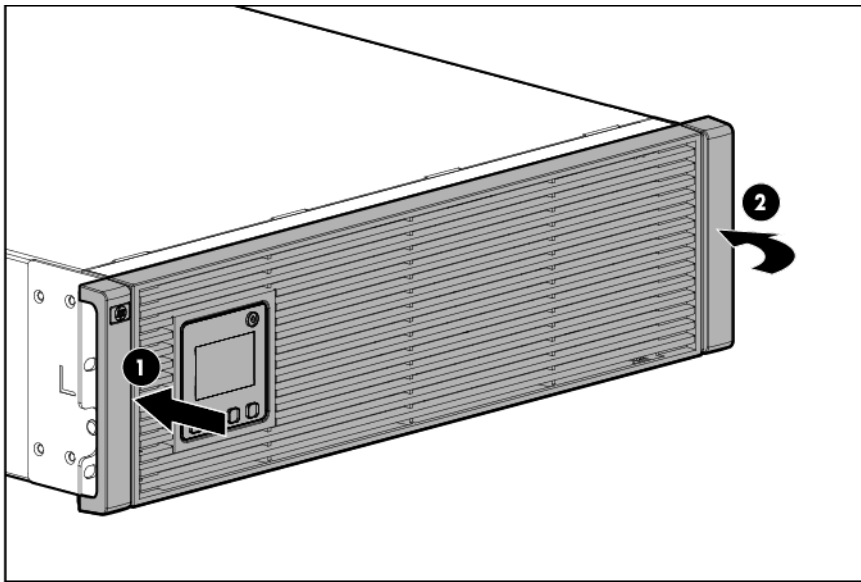

Connecting the serial communications port



CAUTION: Use only the computer interface cable supplied with the UPS to connect the communications port to the host computer.



IMPORTANT: Power protector software requires the communications port to be appropriately cabled to the host computer.

NOTE: This port is only used for firmware upgrades. For additional information, see "Updating the UPS firmware (on page 43)."

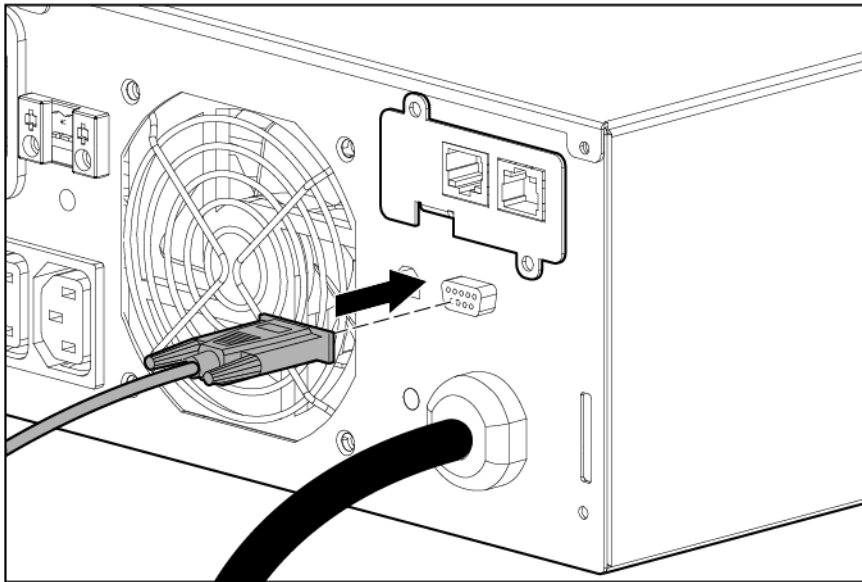

Configuring a USB to serial converter

NOTE: This procedure was tested on the Windows® XP Professional, Windows Server® 2003, and Windows® Vista Enterprise operating systems using the HP USB to serial converter (part number 304098-001). Depending on your system configuration, a driver download might be required to successfully install the converter. The driver can be downloaded from the USB-Drivers website (<http://www.usb-drivers.com/drivers/123/123294.htm>).

To configure a USB port to the COM 1 port on systems that do not have available serial ports:

1. Connect the USB to serial converter to the USB port on your system.
2. For Windows Vista, click **Start**, select **Control Panel**, double-click **System and Maintenance**, and then skip to step 4.
-or-
For Windows XP, click **Start**, select **Control Panel**, click **Performance and Maintenance**, and then click **System**.
-or-
For Windows Server, click **Start**, select **Control Panel**, and then double-click **System**.
3. Click the **Hardware** tab.
4. Click **Device Manager**. The Device Manager screen appears.
5. In the tree displayed in the left panel, click the **Ports (COM & LPT)** branch to expand.
6. Double-click the port that is assigned to your USB to serial converter device. This port is usually named with the device manufacturer's name followed by one of the following:
 - o USB to Serial Bridge (COM 4)
 - o USB Serial port
 - o Communications Port (COM1)The Port Properties screen appears.
7. Click the **Port Settings** tab. The Port Settings screen appears.
8. Click **Restore Defaults**. The following default settings appear:

- Bits per second: 9600
 - Data Bits: 8
 - Parity: None
 - Stop bits: 1
 - Flow control: None
9. Click **Advanced**. The Advanced Settings screen appears.
 10. From the COM Port Number drop down menu, select **Com 1** for the USB port number, and then click **OK**.
If COM 1 is being used by another USB port, the following message appears:
This COM name is being used by another device. Using duplicate names can lead to inaccessible devices and changed settings. Do you want to continue?
If this message appears, click **YES**. It might be necessary to disable the program accessing COM 1.
 - a. Click **OK**.
 - b. For Windows Vista, skip to step 13.
 11. For Windows Server, reduce the Receive Buffer and Transmit Buffer to the low setting by scrolling down to select **low (1)**.
 12. Be sure that the **Use FIFO buffers (requires 16550 compatible UART)** checkbox is selected.
For Windows XP, the USB settings might be different. Choose the lowest, most dependable Receive and Transmit buffers by using the list menus, radio buttons, or other selection methods.
 13. Click **OK** to close the Advanced screen.
 14. Click **OK** to close the Device Manager screen.
 15. Run the firmware Flash batch file program. Follow the instructions provided with the program.

Reassigning the USB COM ports

To reassign a device from COM 1 to another port:

1. From the open Device Manager screen, locate the USB device that is assigned to COM 1.
2. Double-click the port name.
The Port Properties screen appears.
3. Click the **Port Settings** tab.
The Port Settings screen appears.
4. Click **Advanced**.
The Advanced Settings screen appears.
5. Select an available USB port number from the **COM Port Number** drop down menu.
6. Click **OK** to close the Advanced screen.
7. Click **OK** to close the Port Settings screen.
8. Verify that the Device Manager screen shows that the USB to serial converter is assigned to COM 1, and that the other USB device is assigned to a different port.
If the Device Manager screen does not automatically refresh to show the change:
 - a. Click **Action**.
The Action Menu appears.

- b. Click **Scan for hardware changes** to refresh the screen and display the changes.

Connecting the USB communications port

NOTE: This port is only used for firmware upgrades. For additional information, see "Updating the UPS firmware (on page 43)."

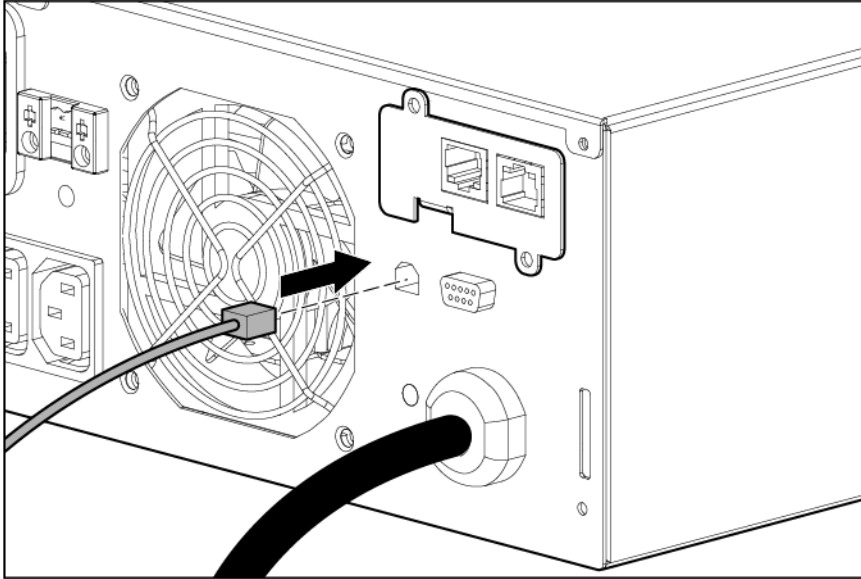

Connecting the REPO port

-
-  **WARNING:** The pins on the REPO port are polarity sensitive. Be sure to verify polarity while connecting the REPO port.

 -  **WARNING:** To meet the requirements stated in NEC (NFPA 70) Articles 645-10 and 645-11, a UPS installed in a computer equipment room must be connected to a REPO circuit.

 -  **IMPORTANT:** The remote switch must be in the Off (open) position to enable power to the output receptacles.
-

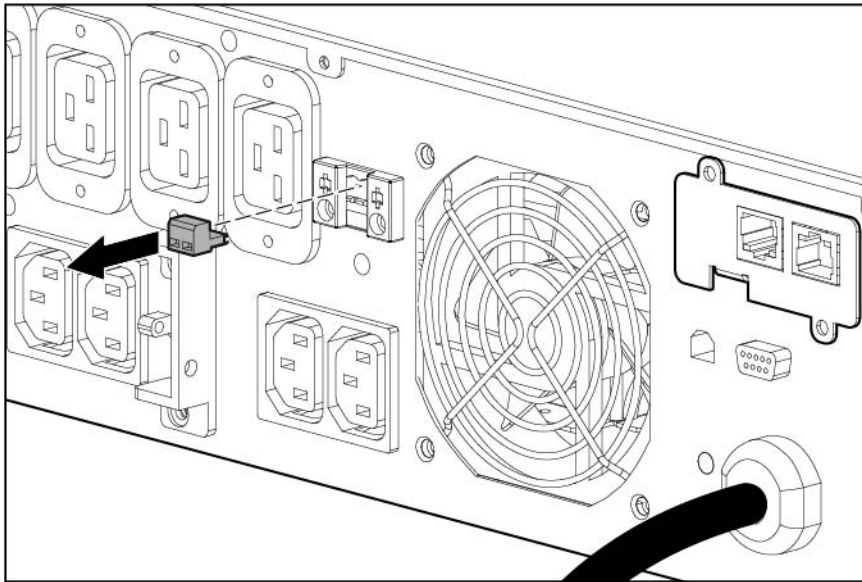

NOTE: Wire the connector block using stranded, nonshielded wire (AWG #22 - #18, or equivalent).

Separate wire pairs are attached to a single, normally-open contact in a parallel connection. HP recommends using different colors for the positive and negative wires.

If a connector becomes disconnected and is reconnected with reversed polarity, a REPO is initiated. To avoid REPO port disconnect:

- Minimize wire strain while connecting the REPO port.
- Avoid allowing the wires to hang in the rear of the UPS.
- Use tie wraps and tie wrap blocks to secure the wires tightly to the rack and the rear of the UPS.

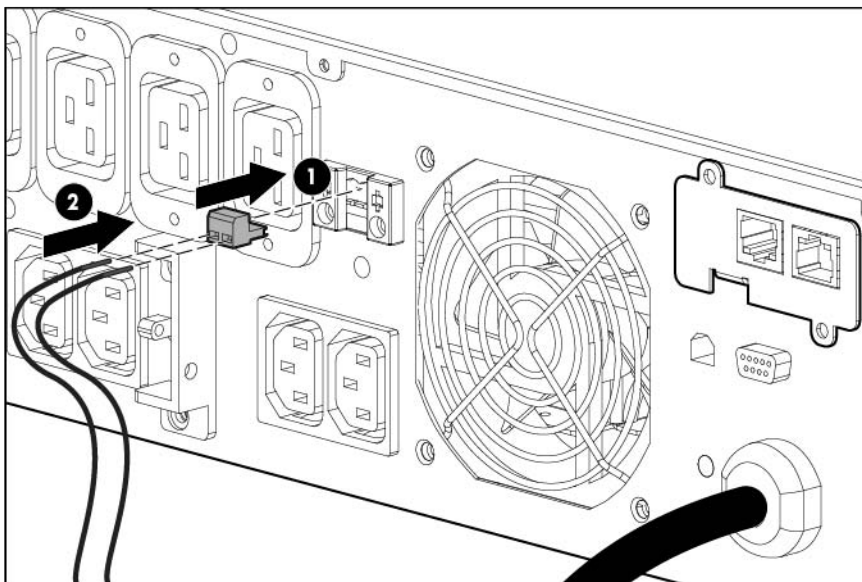

For more information about the REPO port, see "REPO port (on page 9)" .

For information about verifying the REPO connection, see "Verifying the REPO port connection (on page 33)" .

Connecting the ground bonding cable

The ground bonding screw is provided as an attachment point for conductors. Use a ground bonding cable if the rack contains any conductors for the purpose of functional grounding or bonding of ungrounded metal parts.

The ground bonding cable is not included.

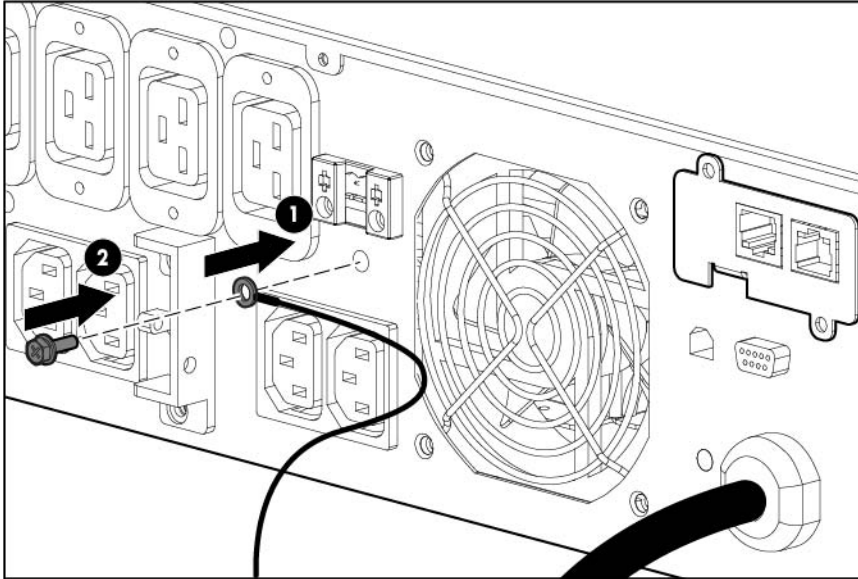

Connecting the network cable

Connect a standard Ethernet cable between the network connector on the UPS Network Module and a network jack.

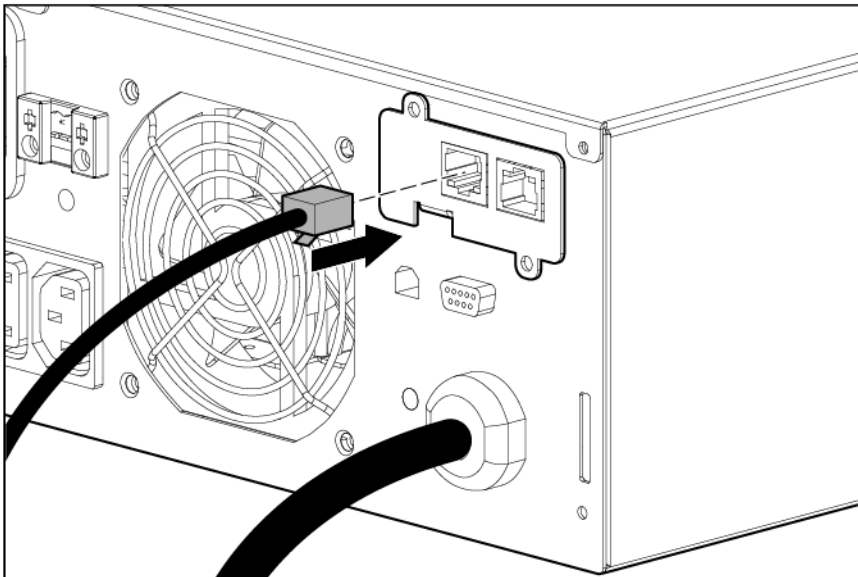

This connection is used to access the UPS Network Module remotely through the web interface. The UPS Network Module also uses the network connection to communicate to the configured HPPP Clients and to facilitate SNMP-based monitoring.

To configure the UPS Network Module, see "Configuring the UPS Network Module (on page 25)."

Connecting the UPS to utility power



WARNING: To prevent injury from electric shock or damage to the equipment:

- Plug the input line cord into a grounded (earthed) electrical outlet that is installed near the equipment and is easily accessible.
 - Do not disable the grounding plug on the input line cord. The grounding plug is an important safety feature.
 - Do not use extension cords.
-

Connect the UPS to a grounded utility power outlet. When the UPS is plugged in, it automatically enters Standby mode and begins charging the batteries.

Connecting devices to the UPS



CAUTION: Do not plug laser printers into the UPS output receptacles. The instantaneous current drawn by this type of printer can overload the UPS.

Before connecting devices:

- Verify that the UPS will not overload by checking that the ratings of the devices do not exceed the UPS capacity.
- Evenly distribute connected devices to both circuit breakers. See "UPS output specifications (on page 50)" for the maximum current rating for each receptacle.

After verifying that the UPS will not overload:

1. Turn on the circuit breakers for load segments 1 and 2.
-

NOTE: The circuit breaker for load segment 1 protects the C19 and C13 outlets but not the large output receptacle.

2. Connect the device power cords to the appropriate output receptacles on the rear panel of the UPS.

To provide additional receptacles, plug a PDU or other device into the high current, large output receptacle. The large output receptacle is part of load segment 1 and can be turned off and on using power management software ("Power Protector software" on page 35).

Connecting the UPS cord retention clips

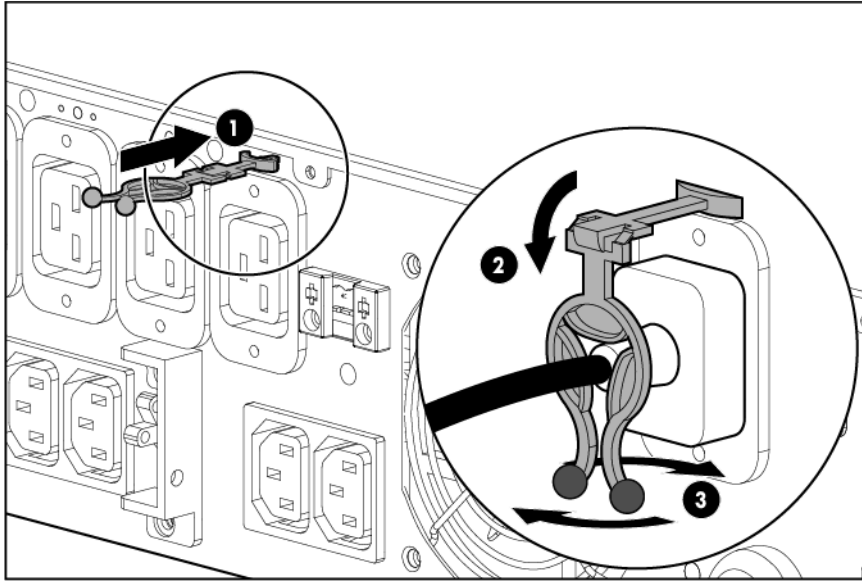

Charging the UPS batteries

With the UPS in Standby mode, allow the batteries to charge before putting the UPS into service.



IMPORTANT: Charge the batteries for at least 24 hours before supplying backup power to devices. The batteries charge to:

- 80 percent of their capacity within 3 hours
- 100 percent of their capacity within 48 hours

Starting power to the load

Start power to the load by placing the UPS in Operate mode.



IMPORTANT: AC power must be available the first time the UPS is started.

Configuring the UPS Network Module

NOTE: For more information about the UPS Network Module, see the HP Infrastructure Management Pack software CD and documentation for complete details.

Before configuring the UPS Network Module, be sure that the network cable is connected.

Connecting the configuration cable

1. Connect the DB-9 connector on the DB-9 to RJ-45 cable to a serial connector on the host computer.

2. Connect the RJ-45 connector on the DB-9 to RJ-45 cable to the Settings/AUX connector on the UPS Network Module.

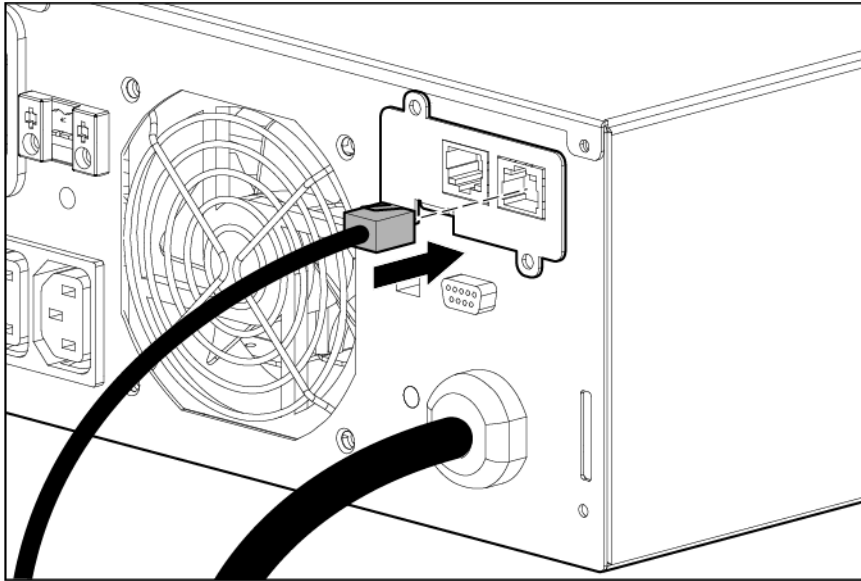

This connection is used to access and configure the UPS Network Module network settings locally through a terminal emulation program.

Launching a terminal emulation program

NOTE: HyperTerminal is the serial communication program provided with Microsoft® Windows® and is used in this section as an example for setting up a terminal emulation session. If you are using another utility, the steps might be different.

1. Be sure that the UPS is powered on.
2. On the host computer, click **Start**, and select **Programs>Accessories>Communications>HyperTerminal**. The Connection Description window appears.
3. Enter a description, select an icon for the connection, and then click **OK**. The Connect To window appears.
4. Select the serial connector on the host computer to which the DB-9 to RJ-45 adapter is attached, and then click **OK**. The COM Properties window appears.
5. Select the following parameter values, and then click **OK**.
 - Bits per second—9600
 - Data bits—8
 - Parity—None
 - Stop bits—1
 - Flow control—None

Configuring the UPS Network Module network settings

On the terminal emulation session screen running on the host computer:

1. Press any key. The initialization process completes, and then you are prompted to enter the password.

2. At the prompt, enter `admin`. The HP UPS Network Module Configuration Menu appears.
Use the HP UPS Network Module Configuration Menu to configure the minimum settings required to access the UPS Network Module remotely.

 **IMPORTANT:** The IP address assigned to the UPS Network Module must be fixed. If the IP address changes:
 - The HPPP Client loses communication with the UPS Network Module.
 - You can lose track of the UPS Network Module URL.

3. If your network is configured with a DHCP server, the network settings are automatically assigned. To view the settings:
 - a. On the Main menu, enter `2` to display the Network Configuration submenu.
 - b. Enter `1` to view the network settings.
 - c. Record the IP address.
 - d. Enter `0` to return to the Main menu.
 - e. Enter `0` to exit the Configuration Menu. The UPS Network Module is operational.

NOTE: You can configure the DHCP server to permanently assign the same IP address for each UPS Network Module using the MAC address of the card.

4. If your network is not configured with a DHCP server:
 - a. On the Main menu, enter `2` to display the Network Configuration submenu.
 - b. Enter `2` to modify the network settings.
 - c. Follow the on-screen instructions to enter the static IP parameters. A `Done` message appears when the parameters are saved.
 - d. Enter `0` to return to the Main menu.
 - e. Enter `1` to reset the UPS Network Module, and then enter `2` to restart the UPS Network Module with the new IP settings.

Accessing the web interface



CAUTION: It is highly recommended that browser access to the UPS Network Module is isolated from outside access using a firewall or isolated network.

1. On a network computer, launch a supported browser. The browser window appears.
2. In the URL field, enter:
`http://xxx.xxx.xxx.xxx`
-or-
`https://xxx.xxx.xxx.xxx`
where `xxx.xxx.xxx.xxx` is the static IP address of the UPS Network Module. The login screen appears.
3. Enter the user name in the User Name field. The default user name is `admin`.
4. Enter the password in the Password field. The default password is `admin`.

5. Click **Sign In**. The HP UPS Network Module web interface appears.

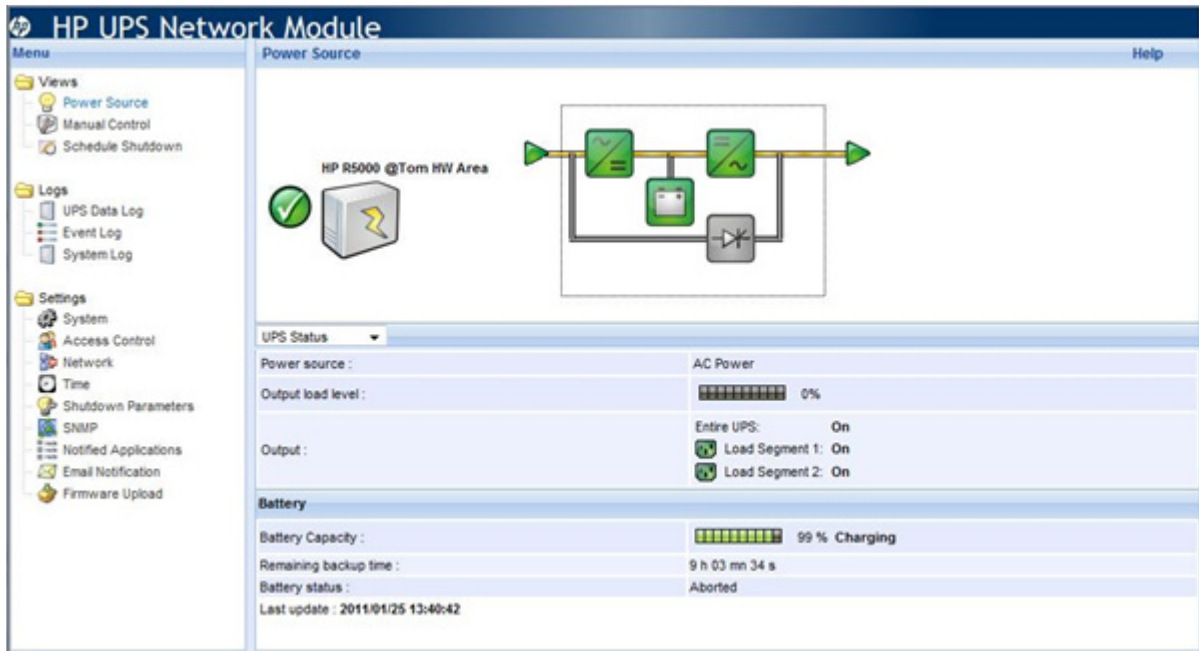

Configuring the UPS Network Module settings

Use the Settings screens of the HP UPS Network Module web interface to configure the UPS Network Module. For more information, see the *HP UPS Network Module User Guide* on the HP website (http://www.hp.com/support/HPNM_Manuals).

Installing the ERM

Before installing the ERM, review and observe all warnings in "Precautions (on page 11)."



WARNING: A risk of personal injury or damage to the equipment exists. Uneven loading of equipment in the rack might cause the rack to become unstable. Install the heavier components first, and then continue to populate the rack from the bottom to the top.

1. Install the mounting rails ("Installing the mounting rails" on page 12).
2. With one person on each side of the carton, lift the chassis and lower it to the floor in front of the rack.

3. Install the mounting ears on the chassis using the screws provided.

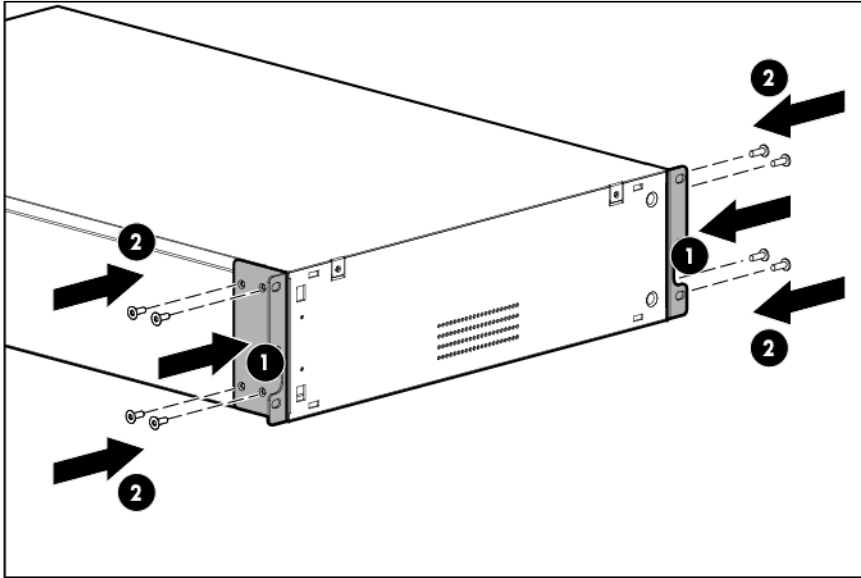

4. With one person on each side, lift the chassis to rail level and slide the chassis on the mounting rails. Be sure that the cleat brackets slide into the channels on the rear stabilization brackets.
5. Attach the chassis to the rack using the supplied screws.

Attaching the ERM front bezel

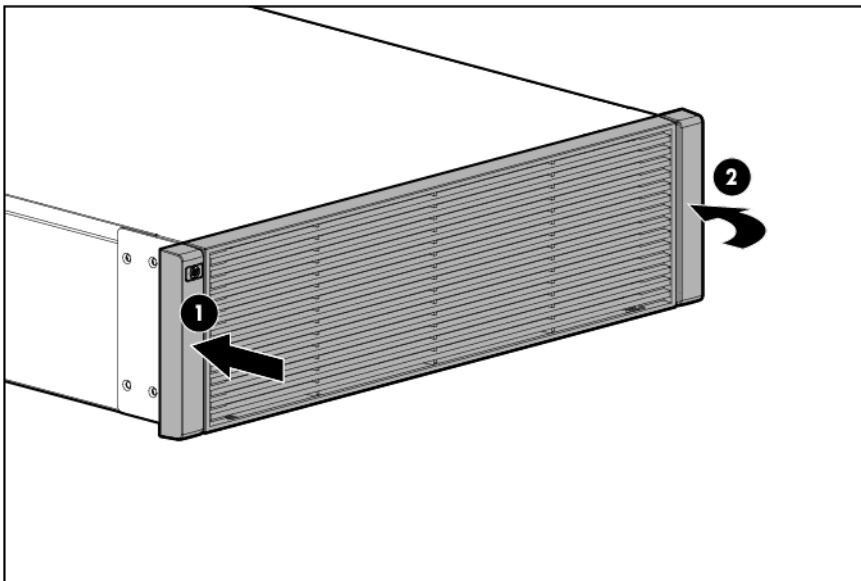

Connecting the ERM to the UPS

Connect both ends of the split ERM cable to the ERM connectors on the UPS rear panel. To install additional ERMs, connect both ends of the split ERM cable from the next ERM into the connectors on the rear panel of the previous ERM. Up to four ERM units can be connected.

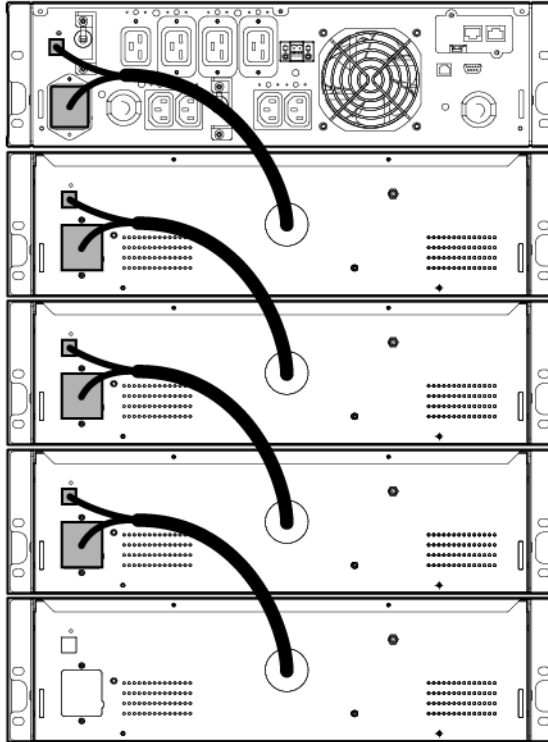

Charging the ERM batteries

Connect the UPS to a grounded utility power outlet. When the UPS is plugged in, it automatically enters Standby mode and begins charging the ERM batteries. With the UPS in Standby mode, allow the ERM batteries to charge for at least 24 hours before putting the UPS into service.



IMPORTANT: To verify the attached ERMs are recognized, confirm the number of installed ERMs using the UPS front panel control via the UPS Status Menu.

UPS operations

Modes of operation

The UPS has three modes of operation:

- Standby mode (on page 31)
- Operate mode (on page 31)
- Auto-Bypass mode (on page 31)

Standby mode

In Standby mode:

- No power is available at the UPS output receptacles.
- The UPS charges the batteries as necessary.

The UPS can be placed in Standby mode when the UPS is in Operate mode (on page 31).

To place the UPS in Standby mode, press and hold the **Power** button. Power to the load ceases.



IMPORTANT: While in Standby mode, the UPS maintains the charge on the batteries, but no power is available at the output receptacles. The UPS remains in Standby mode until an alternate mode is selected or until utility power is removed.

For the location of buttons, see "UPS front panel controls (on page 8)."

Operate mode

In Operate mode:

- Power is available at the UPS receptacles.
- The UPS charges the batteries as necessary.

The UPS can be placed in Operate mode if either of the following conditions apply:

- The UPS is powered on and in Standby mode (on page 31).
- The UPS is powered off and no utility power is available.

To place the UPS in Operate mode, press and hold the **Power** button.

For the location of buttons, see "UPS front panel controls (on page 8)."

Auto-Bypass mode

The UPS automatically enters Auto-Bypass mode when one of the following conditions occurs:

- Extended overload

- Over temperature
- Output short
- Hardware failure

Transferring the UPS between modes

To transfer between Operate mode and Bypass mode:

1. Press the **ESC** button to activate the menu options.
2. Press the down arrow to scroll to the Control menu, and then press the **Enter** button.
3. Press the **Enter** button to select **Go To Bypass Mode**.

To transfer between Bypass mode and Operate mode:

1. Press the **ESC** button to activate the menu options.
2. Press the down arrow to scroll to the Control menu, and then press the **Enter** button.
3. Press the **Enter** button to select **Go to normal mode**.

Configuring the UPS

Use the UPS front panel controls to configure the UPS.

Changing the language

To change the language:

1. Press the **ESC** button to activate the menu options.
2. Press the down arrow button until the Setting menu appears on the LCD menu screen.
3. Press the **Enter** button.
4. Press the down arrow button until the Change Language menu appears on the LCD menu screen.
5. Press the **Enter** button.
6. Press and hold the **Enter** button to change the language on the UPS.

Changing display functions

The control panel automatically dims after a long period of inactivity. Press any button to restore the screen.

Press the **ESC** button to activate the menu options. Use the up and down arrow buttons to scroll through the menu structure. Press the **Enter/Select** button to enter a submenu or to select an option. Press the **ESC** button to cancel or return to the previous menu.

Menu map for display functions

Main menu	Submenu	Display information or menu function
UPS Status	—	Load percentage graph, System Status, Estimated Battery Runtime, Battery Charge, Output Voltage and Output Frequency
—	Alarm status	Displays active alarms

Main menu	Submenu	Display information or menu function
—	Battery status	Battery Charging/Floating/Resting, Charge Level, ERM Number, and Runtime
Event Log	—	Displays events and alarms
Measurements	Output	Output watts and VA
—	Output	Output amps and power factor
—	Output	Output voltage and frequency
—	Input	Input voltage and frequency
—	Battery	Battery voltage and percent charge
Control	Go to Bypass mode	Transfers the UPS system to internal Bypass mode When this command is active, the option changes to Go to Normal mode.
—	Battery Test	Schedules a battery test
—	Reset error state	Reset alarms
—	Load segments	Turns load segments on or off
—	Restore factory settings	Resets the UPS back to factory settings
Settings	Change language	Changes language settings. The default is English.
—	User Password	Enables or disables password. Default: Disable. If Enable is selected, the password is USER. The password cannot be changed.
—	Set date and time	Sets date and time
—	Control commands from serial port	Enables or disables serial port control commands. Default: Enabled
—	Output voltage	Sets output voltage
—	Auto start delay	Selects load segment and delay time in seconds
—	Automatic on battery shutdown	Selects load segment and delay time in seconds
—	On battery notice delay	Sets delay time in seconds
—	Site wiring fault alarm	Enables or disables site wiring fault alarm. The default is Disabled
—	Battery low alarm	Sets battery low alarm. Default: 3 minutes.
—	Automatic battery test	Enables or disables battery test. Default: Disabled
—	LCD contrast	Change LCD contrast. Default: +0
Identification	—	UPS Type / Part Number / Serial Number / NMC Firmware / Comm Firmware / UPS Firmware

Verifying the REPO port connection

NOTE: While testing, operate connected equipment in a safe test mode so the effects do not disrupt critical operations.

After connecting the REPO port (on page 21):

1. Initiate a REPO by closing the REPO contact.



CAUTION: If the polarity is reversed while connecting the REPO port, the UPS powers up normally.

2. Verify proper connection of the REPO port:

- a. Power up the UPS by pressing the Power button.
- b. Disconnect the REPO port.
- c. Reconnect the REPO port.

If the polarity is correct, the REPO connectors can be disconnected, and then reconnected, without initiating a REPO.

- d. Verify that the UPS remains in Operate mode (on page 31).
- e. If a REPO is initiated, the polarity is reversed. Check and correct the connections.

Powering down the UPS

1. Shut down all load devices.
2. Switch the load segment circuit breakers the OFF position.
3. Press and hold the **Power** button for 3 seconds. Power is removed from the load segments and the ON/OFF button blinks.

Power management

Power Protector software

HP Power Protector software ensures maximum power reliability of computer systems through comprehensive control of UPSs. The easy-to-use browser interface enables novice users to configure and manage power protection settings. To download the latest version of HP Power Protector software, see the HP website (<http://www.hp.com/go/rackandpower>).

NOTE: To install and configure the software, see the software user guide. The software user guide is available for download from the HP website (<http://www.hp.com/go/rackandpower>).

HP Power Protector:

- Does not require complex management systems, which simplifies deployment, configuration, and management of UPS-protected environments.
- Manages a graceful shutdown of attached devices during utility power failures.
- Prioritize the shutdown timing of attached computers.
- Customizes alert generation with modifiable dialog boxes, command execution, and email and broadcast messages.
- Monitors the status of the UPS and reports alarms.
- Displays a power log for analysis.
- Manages independent UPS load segments to provide separate power control of attached load devices.

The HP UPS Network Module (P/N AF465A) is a Minislot with an easy-to-use browser interface, which gives you comprehensive control of the UPS and enables you to monitor and effectively manage power environments. The UPS Network Module supports either a single UPS configuration or a dual redundant UPS configuration for no single-point-of-failure.

The UPS Network Module can be configured to send alert traps to HP Systems Insight Manager and other SNMP management programs or used as a stand-alone management system. This flexibility enables you to monitor and manage UPSs through the network. To facilitate day-by-day maintenance tasks, the embedded management software provides detailed system logs.

The UPS Network Module provides remote management of a UPS by connecting the UPS directly to the network. Configuration and management of the UPS from anywhere and at any time through a standard web browser.

The UPS Network Module (Minislot) is ideal for:

- Small to enterprise-sized customers that will benefit from remotely managing their UPS.
- Adding protection via the redundant UPS configuration.
- Gracefully performing scheduled shut-downs of attached equipment.
- Notifying administrative personnel in the event of a power failure.
- Prioritizes the timing of attached load device shutdowns.

- Delays reboot by load segment after a power outage to sequence the startup of system components.

Maintenance

Removing the UPS front bezel

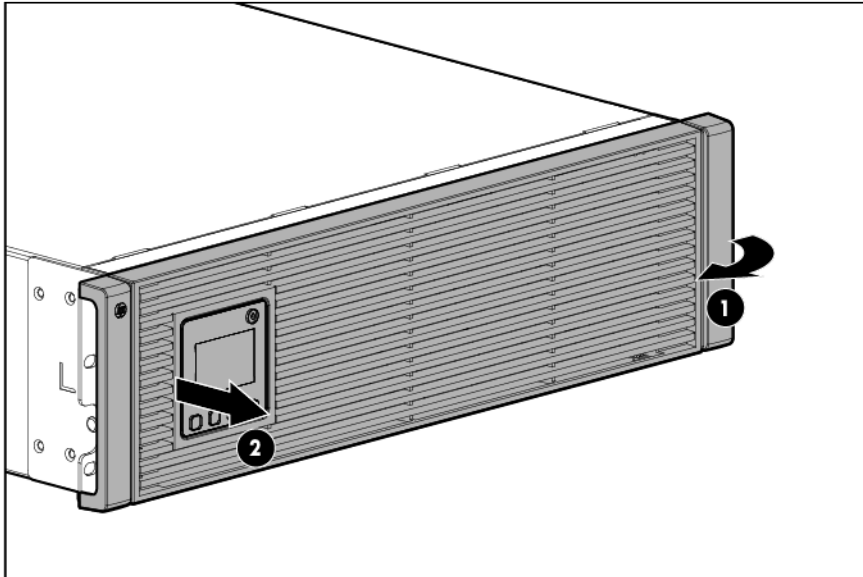

Removing the ERM front bezel

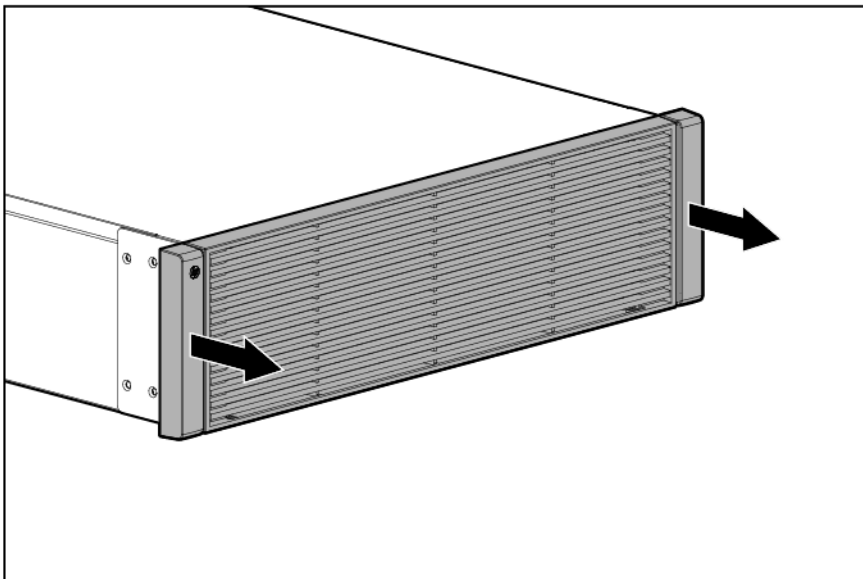

Replacing the UPS Network Module

This component is hot-swappable and can be replaced without powering down the UPS.

1. (optional) To replace the component with the UPS powered down, refer to "Powering down the UPS (on page 34)."
2. Disconnect all cables attached to the UPS Network Module connectors.
3. Remove the two screws securing the UPS Network Module and slide the module out.

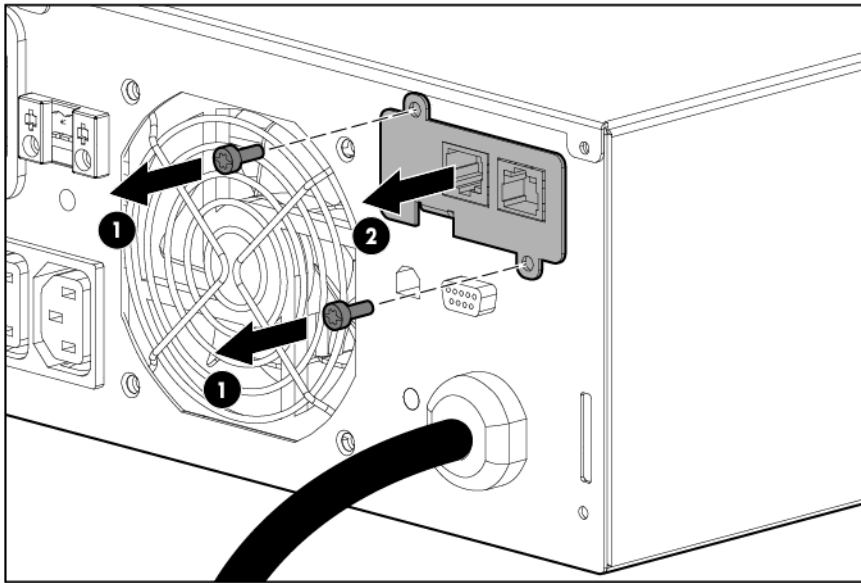

To replace the component, reverse the removal procedure.

NOTE: Replacing the UPS Network Module might require power management software to be restarted or reconfigured.

Replacing the batteries

To replace the batteries:

1. Read and observe the requirements in "Important battery safety information (on page 38)" and "Battery care and storage guidelines (on page 39)."
2. Follow the instructions in "UPS battery replacement procedure (on page 39)."

Important battery safety information



WARNING: The unit contains sealed lead-acid battery modules. To prevent fire or chemical burns:

- Do not attempt to recharge batteries after removal from the unit.
 - Do not disassemble, crush, or puncture the batteries.
 - Do not short the external contacts of the batteries.
 - Do not immerse the batteries in water.
 - Do not expose to temperatures higher than 60°C (140°F).
-



WARNING: To prevent personal injury from hazardous energy:

- Remove watches, rings, or other metal objects.
 - Use tools with insulated handles.
 - Do not place tools or metal parts on top of batteries.
-



WARNING: To prevent personal injury, prepare the area and observe all materials-handling procedures when transporting a battery module. Battery modules weigh 11.1 kg (24.47 lb).

NOTE: Replace all battery modules at the same time with the same type of batteries originally installed in the UPS.

Battery care and storage guidelines

- Minimize the amount of time the UPS uses battery power by matching the UPS configuration with the utility voltage. Refer to "Configuring the UPS (on page 32)."
- Keep the area around the UPS clean and dust-free. If the environment is very dusty, clean the outside of the UPS regularly with a vacuum cleaner.
- Maintain the ambient temperature at 25°C (77°F).
- If storing a UPS for an extended period, recharge the batteries every 6 months:



CAUTION: Because of the short shelf life of the batteries, avoid storing a battery spare as a backup. Do not maintain an inventory of spare batteries on site unless a procedure to keep these batteries charged while in storage is implemented.

- a. Connect the UPS to utility power.
- b. Allow the UPS to remain in Standby mode.
- c. Allow the UPS to charge the batteries for at least 24 hours.
- d. Update the battery recharge date label.

UPS battery replacement procedure

The battery modules are hot-swappable and can be replaced without powering down the UPS.



IMPORTANT: The UPS continues to run while the batteries are replaced and shows the battery disconnected alarm. This alarm clears automatically when the batteries are reconnected.

To remove the component:

1. Remove the UPS front bezel ("[Removing the UPS front bezel](#)" on page 37).

2. Disconnect the battery leads.

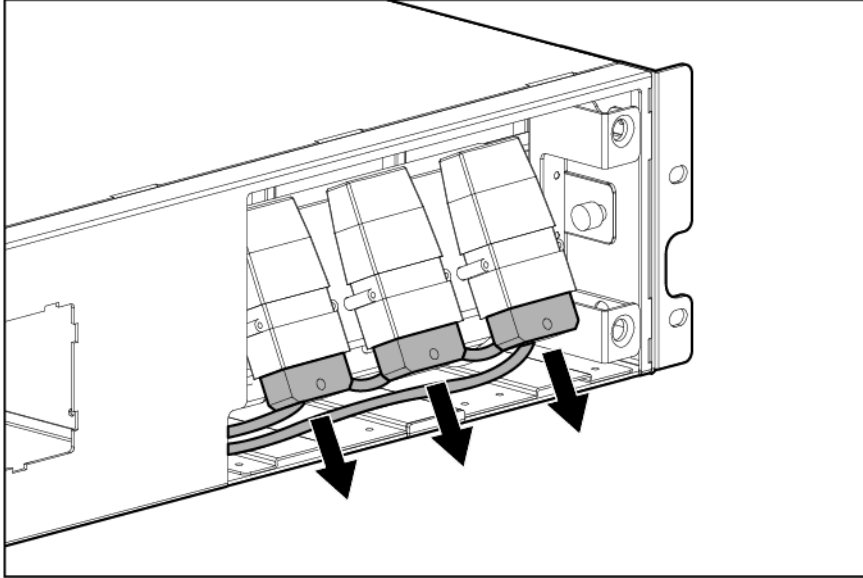

3. Remove the UPS battery bracket.

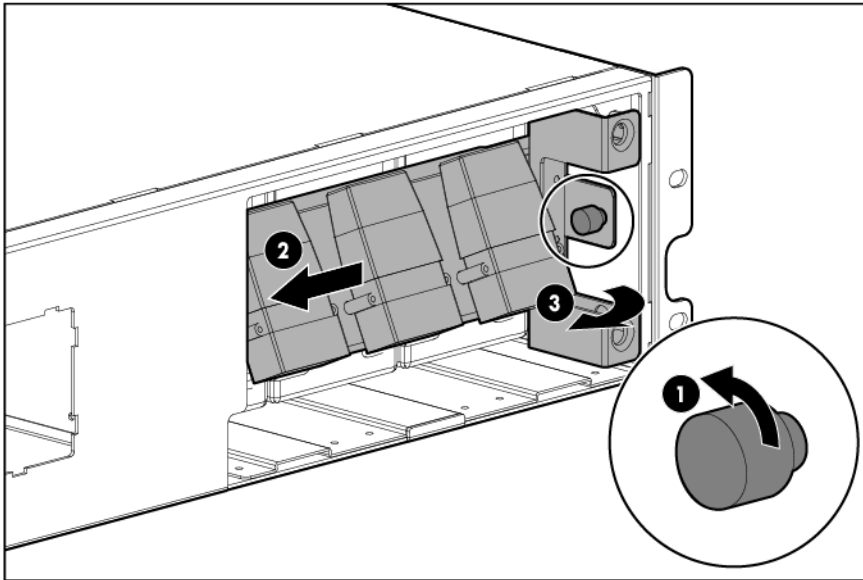

4. Remove the UPS battery modules.



IMPORTANT: Do not pull the battery leads when removing or installing the batteries.

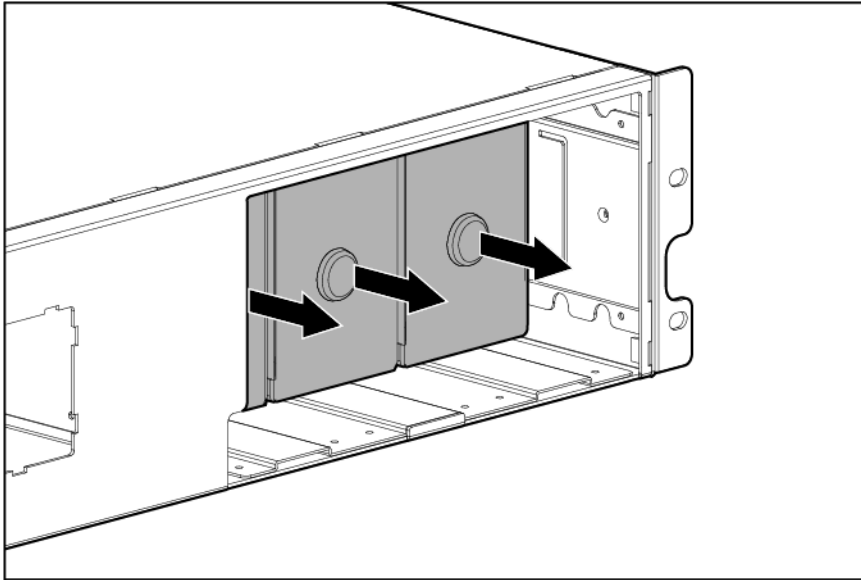

To replace the component, reverse the removal procedure.



IMPORTANT: Charge the batteries for at least 24 hours before supplying backup power to devices. The batteries charge to:

- 80 percent of their capacity within 3 hours
 - 100 percent of their capacity within 48 hours
-

Replacing the UPS

To remove the UPS:

1. Power down all attached load devices.
2. Power down the UPS ("[Powering down the UPS](#)" on page 34).
3. Unplug the UPS power cord.
4. Disconnect all cabling.
5. Remove the UPS front bezel ("[Removing the UPS front bezel](#)" on page 37).

6. Disconnect the battery leads.

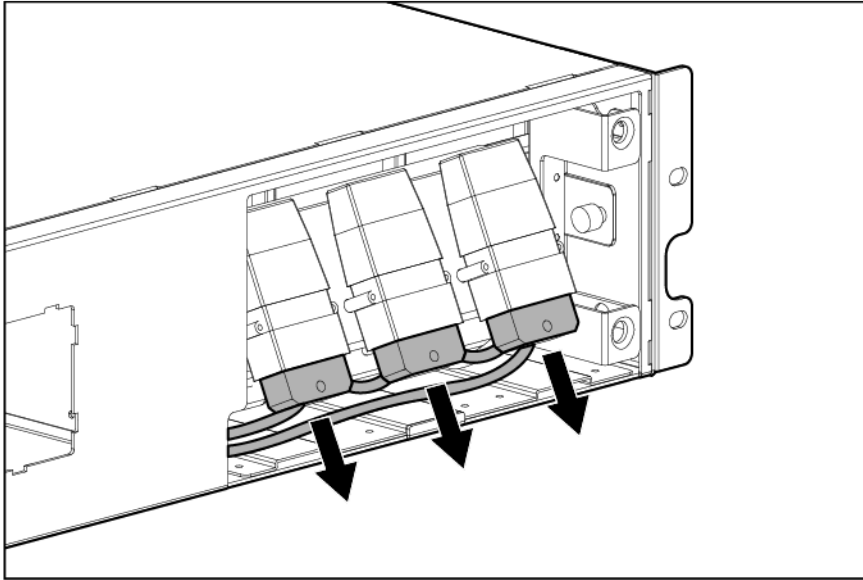

7. Remove the UPS battery bracket.

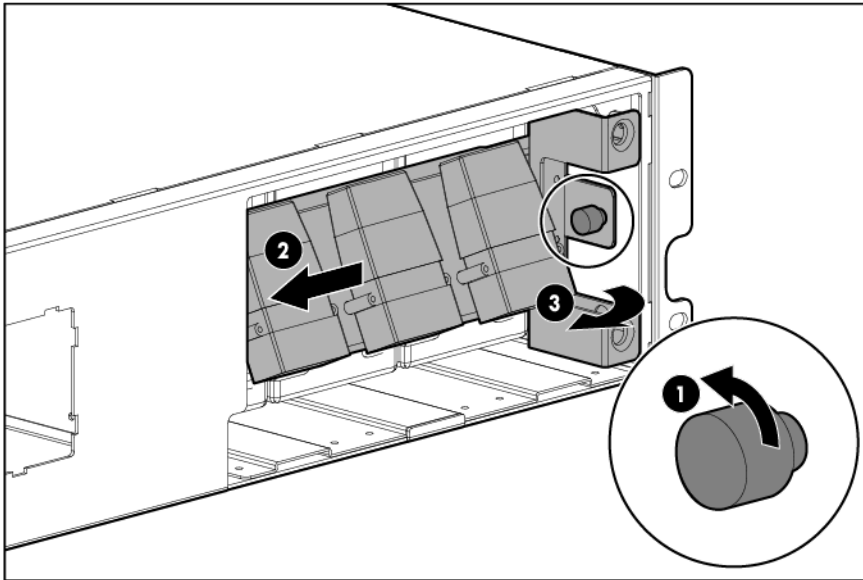

8. Remove the UPS battery modules.

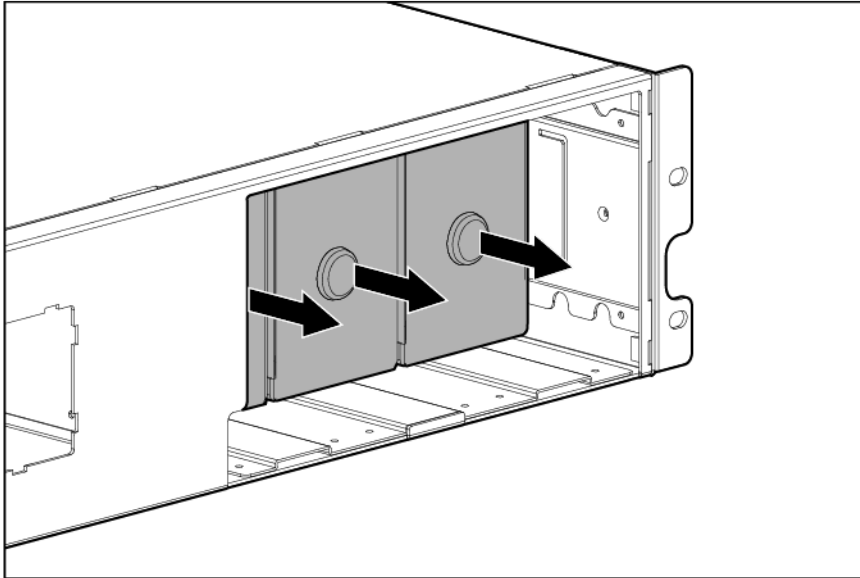

9. Remove the screws securing the UPS to the rack.
10. Remove the UPS from the rack.

To replace the component, reverse the removal procedure.

Replacing the ERM

To remove the ERM:

1. Disconnect all cabling.
2. Remove the front bezel ("[Removing the ERM front bezel](#)" on page 37) on the ERM that is being replaced.
3. Remove the screws securing the ERM to the rack.
4. Remove the ERM from the rack.

To replace the component, reverse the removal procedure.

Updating the UPS firmware

To update the UPS firmware, see the HP website (<http://www.hp.com/go/rackandpower>).

Troubleshooting

Alarm troubleshooting

This UPS is designed for durable, automatic operation and also to alert you whenever potential operating problems might occur. Usually the alarms shown on the control panel do not mean that the output power is affected. Instead, they are preventive alarms intended to alert you of a possible condition.

The following table describes typical alarms and conditions. If an alarm appears with a service code, contact HP technical support ("[Support and other resources](#)" on page 58, "[HP contact information](#)" on page 58).

To check the Event Log for a list of active alarms:

1. Press the **ESC** button on the front panel display to activate the menu options.
2. Press the down arrow button until the Event Log menu appears.
3. Press the **Enter** button to display the list of alarms and conditions.

Alarm number	Alarm name	Alarm description	Alarm type
1	Inverter AC Under Voltage	The UPS has detected abnormally low output voltage levels.	Alarm
6	Input AC Over Voltage	The utility RMS voltage is greater than the maximum valid utility threshold.	Alarm
7	Input AC Under Voltage	The utility RMS voltage is less than the minimum valid utility threshold.	Notice
8	Input Under/Over Frequency	The utility frequency is out of usable frequency range.	Notice
12	Remote Emergency Power Off	The external contacts in the rear of the UPS are configured for REPO operation and they have been activated.	Alarm
25	Output Overload	Load levels are at, or have exceeded, the configurable threshold limit for a Level 1 Overload condition.	Notice
26	Rectifier Input Over Current	The UPS has detected that rectifier input current limits have been exceeded.	Alarm
27	Inverter Output Over Current	The UPS has detected that inverter output current limits have been exceeded.	Alarm
28	DC Link Over Voltage	Indicates the link or rail voltage UPS has exceeded its upper threshold limit.	Alarm
31	Inverter Fault	The UPS has detected a fault in the inverter circuit while attempting recovery from bypass or Fault modes.	Alarm
55	Shutdown Imminent	Indicates that the UPS entered a state where it might stop operating abruptly without notice. An alarm is issued when the BTR reaches 0 at the end of a battery discharge cycle after all connected devices should have shutdown gracefully already.	Alarm
56	Low Battery Warning	Warning alarm indicating battery remain or battery time remaining is lower than the battery low warning level defined for the UPS.	Alarm

Alarm number	Alarm name	Alarm description	Alarm type
59	Utility Not Present	The utility level has fallen below the Utility Not Present threshold.	Notice
68	Battery DC Over Voltage	Battery voltage levels have exceeded the maximum allowable limits.	Alarm
94	To Bypass Command	A request to transfer to Manual Bypass Mode received from software.	Event
95	From Bypass Command	A request to transfer to Operate Mode is received from software.	Event
143	On Manual Bypass	The UPS is manually commanded to switch to bypass and will remain in bypass until commanded out of bypass.	Notice
149	Service Battery	A faulted battery string is detected, and the battery charger has been disabled until it is replaced.	Alarm
159	Output Overload Level 2	Load levels are greater than a level 2 Overload condition and less than a level 3 Overload condition.	Alarm
162	Output Overload Level 3	Load levels are greater than a level 3 threshold.	Alarm
168	UPS On Battery	The UPS is operating from batteries.	Notice
169	UPS On Bypass	The UPS is operating from bypass.	Notice
170	UPS Off	The UPS is in Standby mode or Fault mode.	Event
172	UPS On Command	Indicates a manually requested transition from Standby to Operate. This event is not triggered for auto restarts.	Event
173	UPS Off Command	A UPS OFF command was received from remote S/W and causes the UPS to open up all output relays and shed the load.	Event
174	Battery Shutdown	The UPS has shut down due to running on battery for a long enough time to exhaust the battery capacity.	Alarm
181	UPS Control Power ON	The UPS is powered up.	Event
191	Battery Test Failed	A weak battery string is detected during the battery test.	Notice
194	Site Wiring Problem	The difference between ground and neutral voltage is less than 30 V.	Alarm
199	Battery Disconnected	Battery voltage is lower than the batteries disconnected level defined for this UPS. If ERMs are attached, this alarm does not trigger unless the ERMs are also disconnected, since they are paralleled with the battery bus.	Alarm
237	UPS System Normal	The UPS has started or returned to its normal operating mode of operation and no alarms are active.	Event
1600	ABM State Charging	The status of ABM charge mode is constant current charging.	Event
1601	ABM State Floating	The status of ABM charge mode is floating.	Event
1602	ABM State Resting	The status of ABM charge mode is resting.	Event
1603	ABM State OFF	The status of ABM charge mode is OFF or disabled.	Event
1999	Clock set done	The UPS real time clock setting has been adjusted.	Event

Silencing an audible alarm

To silence an alarm, press any button on the front panel display to silence the alarm. If the alarm status changes, the alarm beeps again, overriding the previous alarm silencing.



IMPORTANT:

- Although the audible alarm silences, the condition that caused the alarm to sound may still exist.
- If a utility power failure caused the alarm, the alarm silences after power is restored.

For information about audible alarm conditions, see "Alarm troubleshooting (on page 44)."

Battery connection condition

Possible cause:

- The UPS does not recognize the internal batteries.
- Two or more battery trays are disconnected.

Action:

1. Be sure that all the battery trays are fully seated and locked in place.
2. If the condition persists, contact an HP authorized service representative.

Bypass is unavailable

Possible cause: The UPS is receiving utility power that might be unstable or in brownout conditions. The UPS continues to supply power to the connected equipment.

Action:

1. Verify the bypass utility.
2. Check for one of the following alarms:
 - Bypass over or under voltage
 - Bypass over or under frequency
 - Bypass unavailable

General alarm condition

Action:

1. If power management software is being used, check the log files to obtain specific error information to help identify the problem.

For more information about the causes of a general alarm condition, see the HP Power Manager user guide available for download from the HP website (<http://www.hp.com/go/rackandpower>).
2. Check the batteries:
 - a. Allow the UPS batteries to charge for 48 hours.
 - b. If a Battery Fault occurs, replace the batteries.
3. Reduce the load:

- a. Power down the UPS ("[Powering down the UPS](#)" on page 34).
 - b. Remove one or more load devices to reduce the power requirements.
 - c. Wait at least 5 seconds and restart the UPS.
 - d. If the condition persists, verify that the load devices are not defective.
4. Allow the UPS to cool:
 - a. Power down the UPS ("[Powering down the UPS](#)" on page 34).
 - b. Clear vents and remove any heat sources.
 - c. Verify that the airflow around the UPS is not restricted.
 5. Wait at least 5 minutes and restart the UPS.
 6. If the condition persists, contact an HP authorized service representative.

Input voltage is out of range

Action:

1. Check the input voltage and reconfigure the UPS ("[Configuring the UPS](#)" on page 32).
2. Contact a qualified electrician to verify that the utility power is suitable for the UPS.

Insufficient warning of low batteries

Action:

1. Verify that the power management software is not delaying the shutdown of attached servers when the UPS is in a low battery condition.
2. Allow the UPS batteries to charge for 48 hours.
3. If a Battery Fault occurs, replace the batteries.

Internal UPS fault condition

Action:

1. Power down the UPS ("[Powering down the UPS](#)" on page 34).
2. If the condition persists, contact an HP authorized service representative.

Low battery shutdowns

Possible cause: Ungraceful shutdown of attached servers occurs when the UPS is in a low battery condition.

Action:

1. Verify that the power management software is not delaying the shutdown of attached servers when the UPS is in a low battery condition.
2. Allow the UPS batteries to charge for 48 hours.
3. If a Battery Fault occurs, replace the batteries.

Overload condition

Possible cause: Power requirements exceed the UPS capacity. For output overload ranges, see "UPS output specifications (on page 50)."

Action:

Remove one or more load devices to reduce the power requirements. The UPS continues to operate, but might switch to Auto-Bypass mode (on page 31) if the load increases.

The alarm resets when the conditions becomes inactive.

REPO condition

Action:

- If the remote switch is closed, then open the switch to enable power to the output receptacles.
- If the condition occurred while reconnecting a disconnected REPO port, then verify the polarity of the REPO connector pins.

For more information about REPO ports, see "Connecting the REPO port (on page 21)."

Site wiring condition

Action: Contact a qualified electrician to be sure that:

- The line and neutral wires are not reversed in the wall outlet.
- A ground wire connection does not exist.

UPS does not provide the expected backup time

Action:

1. Be sure that the battery circuit breakers are in the On position.
2. Allow the UPS batteries to charge for 48 hours.
3. If the condition persists, contact an HP authorized service representative.

UPS does not start

Action:

1. Be sure that the power cord is plugged in to a utility power receptacle.
2. Check the power source at the utility power receptacle.

UPS frequently switches between utility and battery power

Action:

1. Check the input voltage and reconfigure the UPS ("[Configuring the UPS](#)" on page 32).
2. Contact a qualified electrician to verify that the utility power is suitable for the UPS.

UPS is in Auto-Bypass mode

Action:

1. If power management software is being used, check the log files to obtain specific error information to help identify the problem.
For more information about the causes of a general fault condition, see the HP Power Manager user guide available for download from the HP website (<http://www.hp.com/go/rackandpower>).
2. Verify that no blockage of airflow to the front bezel and rear panel exists.

UPS is on battery

Action: Save files and shut down connected equipment.

UPS is on bypass

Possible Cause: The UPS is in Auto-Bypass mode (on page 31).

Action:

The equipment transferred to bypass utility power. Battery mode is not available and the equipment is not protected; however, the utility power continues to be passively filtered by the UPS.

Check for one of the following alarms:

- Overload
- Over temperature
- Output short
- Hardware failure

Utility power condition

The utility input voltage is outside the operating range.

Action:

1. Check the input voltage and reconfigure the UPS ("[Configuring the UPS](#)" on page 32).
2. Contact a qualified electrician to verify that the utility power is suitable for the UPS.

Specifications

UPS physical specifications

Parameter	Value
Height	12.7 cm (5 in)
Depth	74.4 cm (29.3 in)
Width	43.7 cm (17.2 in)
Weight	57 kg (126 lb)

ERM physical specifications

Parameter	Value
Height	12.7 cm (5 in)
Depth	71.9 cm (28.3 in)
Width	43.8 cm (17.24 in)
Weight	63 kg (139 lb)

UPS input specifications

NOTE: An asterisk (*) indicates the default setting.

UPS model	Utility voltage frequency (Hz)	Available settings utility voltage (VAC)	Dedicated branch circuit rating (A)	Line cord
R5000 NA/JPN	50/60	200/208*/220/230/240	30	Nondetachable power cord with NEMA L6-30 plug
R5000 INTL	50/60	200/208/220/230*/240	32	Nondetachable power cord with 32 A IEC-309 plug

UPS output specifications

UPS model	Load segment	Circuit breaker	Output receptacles	Maximum current
R5000 NA/JPN	1	20 A ¹	2 x IEC-320-C19	16 A per receptacle ²
			2 x IEC-320-C13	10 A per receptacle
			1 x L6-30R	Up to full UPS power rating

UPS model	Load segment	Circuit breaker	Output receptacles	Maximum current
	2	20 A ¹	2 x IEC-320-C19	16 A per receptacle ²
			2 x IEC-320-C13	10 A per receptacle
R5000 INTL	1	20 A ¹	2 x IEC-320-C19	16 A per receptacle ²
			2 x IEC-320-C13	10 A per receptacle
			1 x IEC-309-32A	Up to full UPS power rating
	2	20 A ¹	2 x IEC-320-C19	16 A per receptacle ²
			2 x IEC-320-C13	10 A per receptacle

¹ The circuit breakers protect the C19 and C13 outlets.

² If an extension bar is connected to a C19 receptacle, the maximum current for each C13 receptacle on the extension bar is 10 A. The total maximum current for the extension bar is 12 A.

Power protection specifications

UPS model	VA	Nominal power rating (W)	Nominal voltage setting
R5000 NA/JPN	5000	4500	200/208, 220, 230, 240
R5000 INTL	5000	4500	200/208, 220, 230, 240

Voltage specifications

Configuration setting (VAC)	Available nominal output voltage (VAC)
200/208	204
220	220
230	230
240	240

Output tolerance specifications

Source of power	Regulation
Utility power (nominal range)	-10% to +6% of nominal output voltage rating (within the guidelines of the Computer Business Equipment Manufacturers Association)
Battery power	±5% of nominal output voltage rating

Output feature specifications

Feature	Specification
Online efficiency	94% nominal input voltage
Voltage wave shape	Sine wave; 5% THD with typical PFC load

Feature	Specification
Surge suppression	High-energy 6500 A peak
Noise filtering	MOVs and line filter for normal and common mode use

Battery specifications

Feature	Specification
Type	Each model contains maintenance-free, sealed, valve regulated lead-acid batteries with an 8-year minimum float service life at 25°C (77°F).
Voltage	The battery modules have a battery string voltage of 216 V.
Charging	Complete charge takes no more than 48 hours. Approximately 3 hours to 80 percent capacity at default nominal utility voltage and no load.

Average battery runtime

Average battery runtimes are approximate and vary depending on connected equipment, configuration, battery age, temperature, and so on. These estimates are based on the batteries at beginning of life.

Load %	Estimated battery runtime (minutes)	Runtime with one ERM (minutes)	Runtime with four ERMs (minutes)*
20	44	123	436
50	16	44	145
80	7	25	83
100	5.7	20	64

* NA/JPN model only

Minimum battery runtime

Minimum battery runtimes are at beginning of life.

Load %	Internal battery runtime (minutes)	Runtime with one ERM (minutes)	Runtime with four ERMs (minutes)*
20	36	100	360
50	12	36	115
80	6	23	80
100	5	18	58

* NA/JPN model only

Environmental specifications

Feature	Specification
Operating temperature	10°C to 40°C (50°F to 104°F); UL-tested at 25°C (77°F)
Nonoperating temperature	-25°C to 55°C (-13°F to 131°F)
Relative humidity	20% to 80%; noncondensing
Operating altitude	Up to 2,000 m (6,600 ft) above sea level
Nonoperating altitude	15,000 m (49,212 ft) above sea level
Audible noise	Less than 45 dBA, normal operation Less than 50 dBA, on battery power

REPO port specifications

The REPO port meets the requirements of NFPA Articles 645-10 and 645-11 for a Disconnecting Means.

Spares

Ordering spares

To order a spare, visit the HP website (<http://www.hp.com/buy/parts>).

To replace parts under warranty, contact an HP authorized service representative.

UPS spare parts list

Item	Description	Spare part number
1	UPS unit NA/JPN	638826-001
2	UPS unit INTL	638827-002
3	UPS Network Module	636934-001
4	UPS battery module	638829-001
5	ERM unit	638828-001
6	UPS/ERM mounting hardware	638830-001
7	Mounting rail	419181-001
8	Computer interface cable	201092-001

Hardware options

For information on the supported hardware options, see the HP website (<http://www.hp.com/go/rackandpower>).

Regulatory information

Safety and regulatory compliance

For safety, environmental, and regulatory information, see *Safety and Compliance Information for Server, Storage, Power, Networking, and Rack Products*, available at the HP website (<http://www.hp.com/support/Safety-Compliance-EnterpriseProducts>).

BSMI notice

警語： 本產品是在第2類環境中供商業和工業使用，為避免擾動產生，可能需要一些安裝限制或額外的措施。

輸出的電纜長度，網路 LAN 纜線長度，接線使用上，由專業人員安裝，長度不會超過 10 米。

Turkey RoHS material content declaration

Türkiye Cumhuriyeti: EEE Yönetmeliğine Uygundur

Ukraine RoHS material content declaration

Обладнання відповідає вимогам Технічного регламенту щодо обмеження використання деяких небезпечних речовин в електричному та електронному обладнанні, затвердженого постановою Кабінету Міністрів України від 3 грудня 2008 № 1057

Warranty information

HP ProLiant and X86 Servers and Options (<http://www.hp.com/support/ProLiantServers-Warranties>)

HP Enterprise Servers (<http://www.hp.com/support/EnterpriseServers-Warranties>)

HP Storage Products (<http://www.hp.com/support/Storage-Warranties>)

HP Networking Products (<http://www.hp.com/support/Networking-Warranties>)

Limited warranty

To back up the wide range of features offered with the UPS, a 3-year limited warranty is provided.

\$250,000 Computer Load Protection Guarantee

In addition to the limited warranty, a \$250,000 Computer Load Protection Guarantee (provided by the original equipment manufacturer) is offered.



IMPORTANT: The \$250,000 Computer Load Protection Guarantee is offered only in The United States and Canada.

The \$250,000 Computer Load Protection Guarantee only applies if:

- The UPS is plugged into a suitably grounded and wired outlet using no extension cords, adapters, other ground wires, or other electrical connections.
- The UPS installation complies with all applicable electrical and safety codes specified by the NEC.
- The UPS is used under normal operating conditions and users comply with all instructions and labels.
- The UPS is not damaged by accident (other than a utility power transient), misuse, or abuse.
 - The Guarantee applies only to the original end-user and is non-transferable.
 - The Guarantee does not include reimbursement for or restoration of any data loss.
- The UPS is either connected directly to an enterprise class PDU, which is then connected directly to a server, workstation, or personal computer, or the UPS is connected directly to a server, workstation, or personal computer.

Pre-Failure Battery Warranty

The Pre-Failure Battery Warranty, standard on all UPS units, extends the advantage of a 3-year limited warranty by applying it to the battery before it actually fails. The Pre-Failure Battery Warranty ensures that the battery is replaced free of charge when a notification that the battery might fail is received from power protector software. The battery warranty coverage is 3 years for parts. The warranty for the first year of ownership includes parts and labor. If battery spares are not available for a particular UPS model, the entire UPS, including its battery, is replaced.

A Pre-Failure Battery warning is given 30 days before a battery failure. The warning is given in one or both of the following ways:

- The display showing the battery is low.
- Notification from the power protector software.

Recommended duration of use

Although tests and a multitude of customer experiences have shown no noticeable performance issues with UPSs for significant time periods after expiration of the 3-year limited warranty, HP strongly recommends replacing UPSs after a maximum of 5 to 6 years of use to assure full functionality and a safe operating environment. This recommendation does not extend or in any way alter the warranty for UPSs which is limited to a time period of 3 years and a coverage as stated in the applicable warranty statement.

Electrostatic discharge

Preventing electrostatic discharge

To prevent damaging the system, be aware of the precautions you need to follow when setting up the system or handling parts. A discharge of static electricity from a finger or other conductor may damage system boards or other static-sensitive devices. This type of damage may reduce the life expectancy of the device.

To prevent electrostatic damage:

- Avoid hand contact by transporting and storing products in static-safe containers.
- Keep electrostatic-sensitive parts in their containers until they arrive at static-free workstations.
- Place parts on a grounded surface before removing them from their containers.
- Avoid touching pins, leads, or circuitry.
- Always be properly grounded when touching a static-sensitive component or assembly.

Grounding methods to prevent electrostatic discharge

Several methods are used for grounding. Use one or more of the following methods when handling or installing electrostatic-sensitive parts:

- Use a wrist strap connected by a ground cord to a grounded workstation or computer chassis. Wrist straps are flexible straps with a minimum of 1 megohm \pm 10 percent resistance in the ground cords. To provide proper ground, wear the strap snug against the skin.
- Use heel straps, toe straps, or boot straps at standing workstations. Wear the straps on both feet when standing on conductive floors or dissipating floor mats.
- Use conductive field service tools.
- Use a portable field service kit with a folding static-dissipating work mat.

If you do not have any of the suggested equipment for proper grounding, have an authorized reseller install the part.

For more information on static electricity or assistance with product installation, contact an authorized reseller.

Support and other resources

Before you contact HP

Be sure to have the following information available before you call HP:

- Active Health System log (HP ProLiant Gen8 or later products)
Download and have available an Active Health System log for 3 days before the failure was detected. For more information, see the *HP iLO 4 User Guide* or *HP Intelligent Provisioning User Guide* on the HP website (<http://www.hp.com/go/ilo/docs>).
- Onboard Administrator SHOW ALL report (for HP BladeSystem products only)
For more information on obtaining the Onboard Administrator SHOW ALL report, see the HP website (<http://h20000.www2.hp.com/bizsupport/TechSupport/Document.jsp?lang=en&cc=us&objectID=c02843807>).
- Technical support registration number (if applicable)
- Product serial number
- Product model name and number
- Product identification number
- Applicable error messages
- Add-on boards or hardware
- Third-party hardware or software
- Operating system type and revision level

HP contact information

For United States and worldwide contact information, see the Contact HP website (<http://www.hp.com/go/assistance>).

In the United States:

- To contact HP by phone, call 1-800-334-5144. For continuous quality improvement, calls may be recorded or monitored.
- If you have purchased a Care Pack (service upgrade), see the Support & Drivers website (<http://www8.hp.com/us/en/support-drivers.html>). If the problem cannot be resolved at the website, call 1-800-633-3600. For more information about Care Packs, see the HP website (<http://pro-aq-sama.houston.hp.com/services/cache/10950-0-0-225-121.html>).

Acronyms and abbreviations

ERM

extended runtime module

IEC

International Electrotechnical Commission

PDU

power distribution unit

PFC

power factor corrected

REPO

remote emergency power off

RMS

root-mean-square

UPS

uninterruptible power system

Documentation feedback

HP is committed to providing documentation that meets your needs. To help us improve the documentation, send any errors, suggestions, or comments to Documentation Feedback (<mailto:docsfeedback@hp.com>). Include the document title and part number, version number, or the URL when submitting your feedback.

Index

A

authorized reseller 58

B

backup time, insufficient 48
batteries, care and storage 39
batteries, charging 25
batteries, replacing 38, 39
battery replacement notice 55
battery warranty 55
bezel, removing 37
BSMI notice 55
buttons 7, 8

C

Canadian notice 55
charging batteries 25
circuit breakers, location 8, 10
circuit breakers, switching on 24
components, identification 7, 8, 10
configuration of system 32
connecting devices to UPS 24
connectors 7, 8, 10
contacting HP 58
cord retention clip locations 8
cord retention clips, connecting 25

D

Declaration of Conformity 55
devices, connecting 24
disposal, battery 55

E

electrostatic discharge 57
environmental specifications 53
ERM, configuring 32
ERM, connecting 30
ERM, identifying components 10
ERM, installing 28
ERM, replacing 43

European Union notice 55

F

Federal Communications Commission (FCC)
notice 55
firmware, updating 43
frequent switching between battery and utility
power 48
front panel buttons 8
front panel components 7

G

ground bonding cable, connecting 23
grounding methods 57

H

hardware options 54
hardware, preparing to install 11
high-current output receptacle, connecting 24
high-current output receptacle, location 8
HP technical support 58

I

input voltage is out of range 47
installing the ERM 28
insufficient backup time 48
internal UPS fault condition 47

J

Japanese notice 55

L

LCD panel 7
LEDs, troubleshooting 44
limited warranty 55
load protection guarantee 55
load segments, location 8

M

maintenance 37

modifications, FCC notice 55

N

nominal voltage, configuring 32

O

operations, UPS 31

optional items 54

ordering spares 54

output feature specifications 51

output tolerance specifications 51

overload condition 48

overview, REPO port 9

overview, UPS 6

P

phone numbers 58

power management 35

power protection specifications 50

preparation procedures 11

problem diagnosis 44

R

rear panel connectors 8, 10

receptacles, illustrated 8

regulatory compliance identification numbers 55

regulatory compliance notices 55

replacing the batteries 38, 39

replacing the ERM 43

replacing the UPS 41

REPO condition 48

REPO port, connecting 21

REPO port, location 8

REPO port, overview 9

REPO port, specifications 53

required information 58

required tools 11

S

safety considerations 11, 55

series number 55

shipping the UPS 16

site wiring condition 48

spare part numbers 54

spares 54

specifications 50

static electricity 57

storing batteries 39

support 58

supported hardware 54

system configuration settings 32

T

Taiwan battery recycling notice 55

technical support 58

telephone numbers 58

temperature ranges (environmental) 53

tools 11

troubleshooting 44

U

unpacking the components 12

updating the firmware 43

UPS does not start 48

UPS firmware, updating 43

UPS is on battery 49

UPS Network Module 6, 25, 28

UPS operations 31

UPS, replacing 41

utility power condition 49

utility power, connecting 24

V

voltage specifications 51