

# **MARINE RADAR/ARPA**

## **FAR-2117/2127/2817/2827**

### **FAR-2117-BB/2127-BB**

#### **FAR-2117-D/2127-D/2817-D/2827-D**

## ***Installation Manual***

---

### TABLE OF CONTENTS

SAFETY IINSTRUCTIONS .....	i	3.7 Dual Radar Display (non IMO-type only) .....	3-16
EQUIPMENT LISTS .....	iii	4. INSTALLING OPTIONAL EQUIPMENT .....	4-1
SYSTEM CONFIGURATION .....	vi	4.1 Gyro Converter GC-10 .....	4-1
1. MOUNTING.....	1-1	4.2 Memory Card Interface Unit.....	4-9
1.1 Antenna Unit.....	1-1	4.3 DVI-RGB Conversion Kit (for VDR connection) .....	4-12
1.2 Monitor Unit.....	1-6	4.4 Performance Monitor PM-31 .....	4-15
1.3 Control Unit .....	1-10	4.5 BNC Connector Converter .....	4-17
1.4 Processor Unit.....	1-15	4.6 Junction Box.....	4-18
2. WIRING .....	2-1	5. INPUT/OUTPUT DATA .....	5-1
2.1 Interconnection.....	2-1	INSTALLATION MATERIALS, ACCESSORIES,SPARE PARTS .....	A-1
2.2 Antenna Unit.....	2-2	OUTLINE DRAWINGS .....	D-1
2.3 Monitor Unit.....	2-6	INTERCONNECTION DIAGRAMS ...	S-1
2.4 Processor Unit.....	2-7		
2.5 Changing AC Power Specification of Processor Unit .....	2-12		
3. SETTING AND ADJUSTMENT ....	3-1		
3.1 DIP Switch Setting .....	3-1		
3.2 Initializing Tuning.....	3-2		
3.3 Heading Alignment.....	3-3		
3.4 Adjustment Sweep Timing.....	3-6		
3.5 Suppressing Main Bang .....	3-7		
3.6 Other Settings .....	3-8		

**FURUNO ELECTRIC CO., LTD.**[www.furuno.co.jp](http://www.furuno.co.jp)

**ECF**

(Elemental Chlorine Free)

The paper used in this manual  
is elemental chlorine free.

**FURUNO ELECTRIC CO., LTD.**

9-52 Ashihara-cho,  
Nishinomiya, 662-8580, JAPAN

Telephone : +81-(0) 798-65-2111

Fax : +81-(0) 798-65-4200

• FURUNO Authorized Distributor/Dealer

All rights reserved. Printed in Japan

Pub. No. IME-35190-L

(HIMA ) FAR-2117/27/2817/27

A : JAN. 2004

L : FEB. 04, 2011









\* 0 0 0 1 4 7 4 5 4 1 9 \*





# SAFETY INSTRUCTIONS

The operator and installer must read the applicable safety instructions before attempting to install or operate the equipment.

 <b>DANGER</b>	Indicates a potentially hazardous situation which, if not avoided, will result in death or serious injury.
 <b>WARNING</b>	Indicates a potentially hazardous situation which, if not avoided, could result in death or serious injury.
 <b>CAUTION</b>	Indicates a potentially hazardous situation which, if not avoided, can result in minor or moderate injury.

 Warning, Caution	 Prohibitive Action	 Mandatory Action
--	--	--

** DANGER**

 **Wear a safety belt and hard hat when working on the antenna unit.**

Serious injury or death can result if someone falls from the radar antenna mast.

** WARNING**

** Radio Frequency Radiation Hazard**

The radar antenna emits electromagnetic radio frequency (RF) energy which can be harmful, particularly to your eyes. Never look directly into the antenna aperture from a close distance while the radar is in operation or expose yourself to the transmitting antenna at a close distance. Distances at which RF radiation level of 100, 50 and 10 W/m<sup>2</sup> are given in the table below.

**Note:** If the antenna unit is installed at a close distance in front of the wheel house, your administration may require halt of transmission within a certain sector of antenna revolution. This is possible. Ask your FURUNO representative or dealer to provide this feature.

Model	Transceiver	Magnetron	Antenna *1	100W/m <sup>2</sup>	50W/m <sup>2</sup>	10W/m <sup>2</sup>
FAR-2817/2117	RTR-078 (X-12 kw)	MG4010/ MAF1425B	XN-12AF	0.3 m	1.2m	3.7 m
			XN-20AF	0.1 m	0.7 m	2.2 m
			XN-24AF	0.1 m	0.4 m	1.5 m
FAR-2827/2127	RTR-079 (X-25 kw)	MG5436	XN-12AF	0.9 m	2.6 m	9.0 m
			XN-20AF	0.5 m	1.7 m	4.6 m
			XN-24AF	0.2 m	1.0 m	3.3 m

\* : XN12AF: 4 ft, XN20AF: 6.5 ft, XN24AF: 8 ft

## **WARNING**



**Do not open the equipment unless totally familiar with electrical circuits and service manual.**

**ELECTRICAL  
SHOCK  
HAZARD**

Only qualified personnel should work inside the equipment.

**Construct a suitable service platform from which to install the antenna unit.**

Serious injury or death can result if someone falls from the radar antenna mast.

**Turn off the power at the mains switchboard before beginning the installation.**

Fire, electrical shock or serious injury can result if the power is left on or is applied while the equipment is being installed.

**Be sure that the power supply is compatible with the voltage rating of the equipment.**

Connection of an incorrect power supply can cause fire or damage the equipment .

**Use only the specified power cable.**

Fire or damage to the equipment can result if a different cable is used.

**Do not install the monitor unit, processor unit or control unit where they may get wet from rain or water splash.**

Water in the units can result in fire, electrical shock, or damage the equipment.



**Attach securely protective earth to the ship's body.**

The protective earth (grounding) is required to the AC power supply to prevent electrical shock.

## **CAUTION**

**Observe the following compass safe distances to prevent deviation of a magnetic compass:**

	Standard compass	Steering compass
Antenna Unit (12 kw)	2.15 m	1.40 m
Antenna Unit (25 kw)	2.05 m	1.30 m
Monitor Unit (MU-201CR)	1.55 m	1.00 m
Monitor Unit (MU-231CR)	1.85 m	1.20 m
Processor Unit (RPU-013)	1.35 m	0.85 m
Control Unit (RCU-014)	0.30 m	0.30 m
Control Unit (RCU-015)	0.95 m	0.60 m
Control Unit (RCU-016)	0.65 m	0.45 m
Memory Card Interface Unit (CU-200)	0.90 m	0.60 m
Junction Box (RJB-001)	1.10 m	0.70 m
Switching Hub (HUB-100)	1.00 m	0.60 m
Monitor Unit (MU-190)	1.65 m	1.05 m
Monitor Unit (MU-231)	0.85 m	0.55 m

# EQUIPMENT LISTS

## Standard Supply

Name	Type	Code No.	Qty	Remarks
Antenna Unit	XN12AF-RSB096-078	-	1	FAR-2117/2117-BB/2817, 24 rpm, 1200 mm, W/CP03-24201
	XN12AF-RSB097-078	-		FAR-2117/2117-BB/2817, 42 rpm, 1200 mm, W/CP03-24201
	XN20AF-RSB096-078	-		FAR-2117/2117-BB/2817, 24 rpm, 2000 mm, W/CP03-19101
	XN20AF-RSB097-078	-		FAR-2117/2117-BB/2817, 42 rpm, 2000 mm, W/CP03-19101
	XN24AF-RSB096-078	-		FAR-2117/2117-BB/2817, 24 rpm, 2400 mm, W/CP03-19101
	XN24AF-RSB097-078	-		FAR-2117/2117-BB/2817, 42 rpm, 2400 mm, W/CP03-19101
	XN12AF-RSB096-079	-		FAR-2127/2127-BB/2827, 24 rpm, 1200 mm, W/CP03-24201
	XN12AF-RSB097-079	-		FAR-2127/2127-BB/2827, 42 rpm, 1200 mm, W/CP03-24201
	XN20AF-RSB096-079	-		FAR-2127/2127-BB/2827, 24 rpm, 2000 mm, W/CP03-19101
	XN20AF-RSB097-079	-		FAR-2127/2127-BB/2827, 42 rpm, 2000 mm, W/CP03-19101
	XN24AF-RSB096-079	-		FAR-2127/2127-BB/2827, 24 rpm, 2400 mm, W/CP03-19101
	XN24AF-RSB097-079	-		FAR-2127/2127-BB/2827, 42 rpm, 2400 mm, W/CP03-19101
Monitor Unit	MU-201CR	-	1	For FAR-2117/2127
	MU-231CR			For FAR-2817/2827
	MU-190			For FAR-2117-D/2127-D
	MU-231			For FAR-2817-D/2827-D
Processor Unit	RPU-013	-	1	
Control Unit	RCU-014	-	1	Standard type
	RCU-015			Trackball type
Installation Materials	CP03-25601	008-535-550	1	For antenna unit
	CP03-25700	000-080-435	1	15 m signal cable RW-9600
	CP03-25710	000-080-436		30 m signal cable RW-9600
	CP03-25720	000-080-437		50 m signal cable RW-9600
	CP03-25730	000-082-191		40 m signal cable RW-9600
	CP03-25800	000-080-434	1	Cable assy. for monitor unit
	CP03-25602	008-535-940	1	For RPU-013, AC set
	CP03-25603	008-535-950		For RPU-013, DC set
Accessories	FP03-09810	008-536-010	1	For monitor unit
	FP03-09850	008-535-610	1	For RCU-014
	FP03-09860	008-535-690		For RCU-015/016

Spare Parts	SP03-12501	008-485-360	1	For antenna unit
	SP03-14404	008-535-910	1	For processor unit 100 VAC set
	SP03-14405	008-535-920		For processor unit 220 VAC set
	SP03-14406	008-535-930		For processor unit 24 VDC set
	SP03-14401	008-535-990	1	For monitor unit AC set
	SP03-03900	000-081-063		For monitor unit, DC set, MU-201CR
	SP03-14402	008-536-000		For monitor unit, DC set, MU-231CR

## Optional Equipment

Name	Type	Code No.	Remarks	
Gyro Converter	GC-10-2	000-080-440	See chapter 4.	
Performance Monitor	PM-31	000-080-438	Mandatory for IMO radar	
Transformer Unit	RU-1803	-	Converts 440 VAC to 100 VAC, for processor unit	
	RU-3305	-	Converts 110/115/220/230 VAC to 100 VAC, for de-icer	
Rectifier	RU-3424	-	115/230 VAC to 24 VDC, for processor unit (25 kW)	
	RU-1746B-2	-	115/230 VAC to 24 VDC, for processor unit (12 kW)	
	RU-3423	-	100/110/115/220/230 VAC to 24 VDC, for monitor unit	
Memory Card Interface Unit	CU-200-FAR	000-081-568	W/CP03-27430, See chapter 4.	
External Buzzer	OP03-21	000-030-097		
Control Unit	RCU-016	-	Remote type, W/FP03-09860	
RAM Card	00RAM08MC-005	004-376-740	8 MB	
DVI-RGB Conversion Kit	OP03-180-1	008-545-590	Mounted at factory	
	OP03-180-2	008-536-070	Mounted in field. See chapter 4.	
	OP03-180-3	008-545-610	Mounted in console at factory.	
	OP03-180-4	008-545-600	Mounted in console in field.	
Cable Assy.	XH10P-W-6P L=20M	000-149-748	20 m	Between control & processor unit
	XH10P-W-6P L=30M	000-149-749	30 m	
	XH10P-W-5P-A L=10M	000-149-050	10 m	Between control units
	XH10P-W-5P-A L=20M	000-149-051	20 m	
	XH10P-W-5P-A L=30M	000-149-052	30 m	
	DVI-D/D S-LINK 10M	000-150-200	10 m	Monitor-Processor
	S03-9-5	008-206-640	For external radar, 5 m, 8-8P	
	S03-9-10	008-206-650	For external radar, 10 m, 8-8P	
	S03-9-15	008-209-160	For external radar, 15 m, 8-8P	

LAN Cable Kit (with armor)	OP03-28900	000-082-658	FR-FTPC-CY 10 m	Modular connection MPS588-C, 2 pcs.
	OP03-28910	000-082-629	FR-FTPC-CY 20 m	
	OP03-28920	000-082-660	FR-FTPC-CY 30 m	
Accessories	FP03-09820	008-535-560	Hanger assy. for MU-201CR	
	FP03-09830	008-536-020	Hanger assy. for MU-231CR	
Hand Grip	FP03-09840	008-535-570	For monitor unit	
Dust Cover	03-163-1201	100-307-260	For MU-201CR	
	03-163-2101	100-307-270	For MU-231CR	
Hood	FP03-11500	001-020-090	For MU-201CR	
	FP03-11000	008-571-680	For MU-231CR	
Clamp Plate	OP03-182	008-535-620	For RCU-014	
Flush Mount Kit	FP03-09870	008-535-630	For control unit	
	OP03-198	001-008-050	RCU-016/014/015	
Coupling Pedestal	OP03-183	008-535-640	For RCU-014&MU-201CR	
	OP03-184	008-535-650	For RCU-014& MU-231CR	
	OP03-185	008-535-660	For RCU-014	
BNC Connector Converter	DSUB-BNC-1	000-148-528	For VDR	
Junction Box	RJB-001	-	For more than 100m antenna cable	
Desktop Mount Kit	FP03-10201	008-539-530	For CU-200	
Console Mount Kit	FP03-10202	008-539-540	For CU-200	
Switching Hub	HUB-100	-	See manual of HUB-100.	
Slim Hood	FP03-11010	001-033-140	For MU-231CR display unit	
	FP03-11510	001-034-390	For MU-201CR display unit	

### About the category sticker

This radar meets the requirements in IEC62388 (Marine navigation and radiocommunication equipment and systems – Shipborne radar – Performance requirements, method of testing and required test results)

Check the appropriate box on the sticker which is pre-attached on the processor unit, according to your radar's specification. Refer to the table shown below to confirm your category.

Category	Radar type	ANT. rotation speed
CAT 1	FAR-2817/-D, FAR-2827/-D, FAR-2837S/-D, FAR-2827W/-D, FAR-2837SW/-D	Normal speed
CAT 1H	FAR-2817/-D, FAR-2827/-D, FAR-2837S	HSC
CAT 2	FR-2117/BB/-D, FAR-2127/BB/-D, FAR-2137S/BB/-D	Normal speed
CAT 2H	FAR-2117/BB/-D, FAR-2127/BB/-D, FAR-2137S/BB/-D	HSC

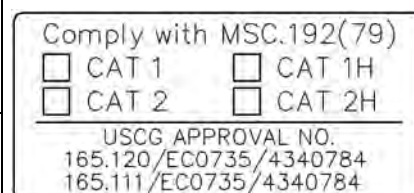

Sticker for Category

# SYSTEM CONFIGURATION

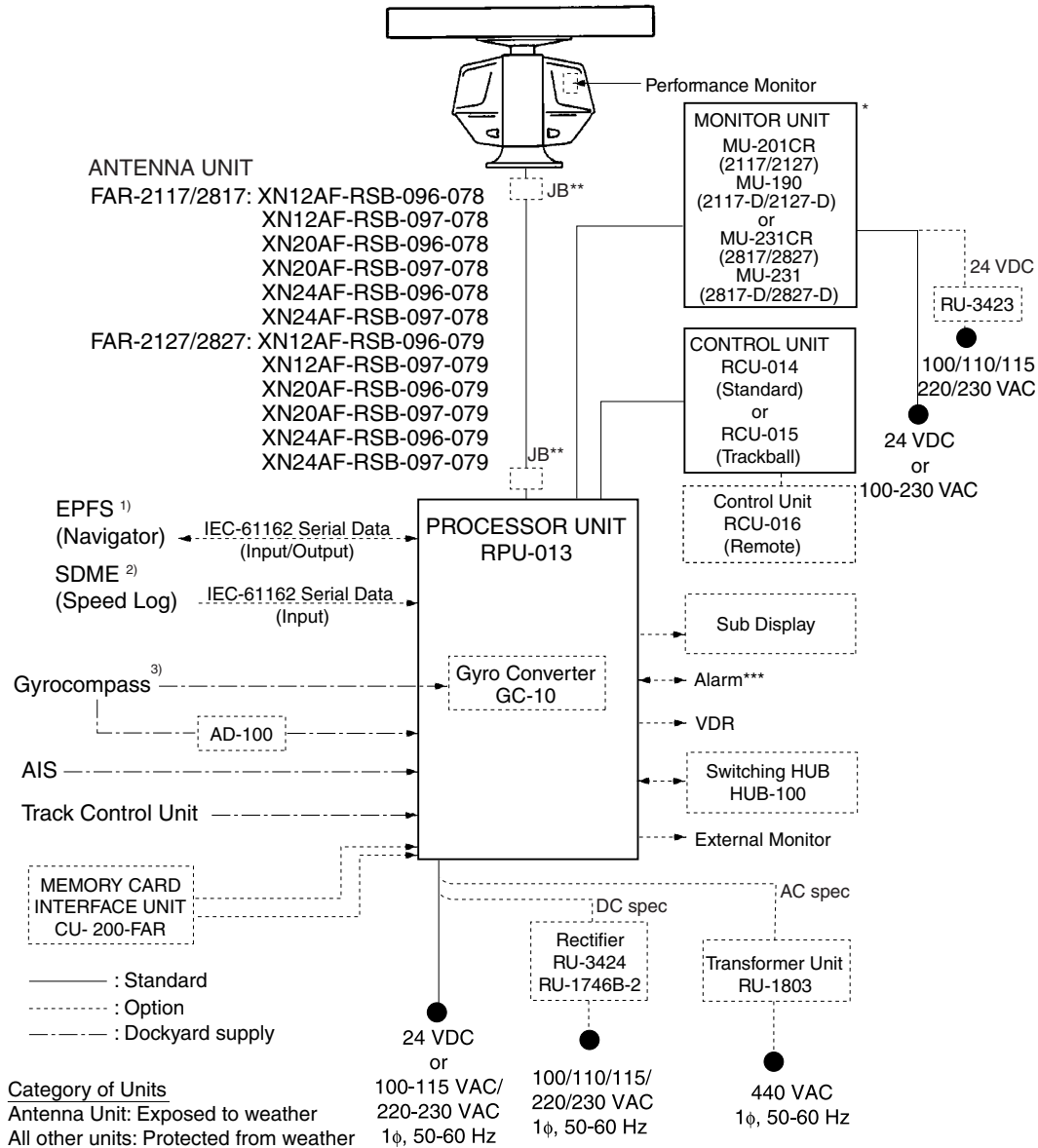

1) Connect the EPFS which is approved in accordance with the requirements of the IMO in resolution MSC.112(73) is used.

2) Connect the SDME which is approved in accordance with the requirements of IMO in resolution MSC.96(72) is used.

3) Use the gyrocompass having an update rate that is adequate for the ship's rate of turn.

\*: For FAR-2117-BB/2127-BB a monitor unit is prepared by user. See page 1-6.

These monitors have been approved by the IMO, MU-201CR for CAT 2, MU-231CR for CAT 1. If a different monitor is to be used, its effective diameter must meet the applicable Category requirements: CAT 1: effective diameter 320 mm or higher, CAT 2: effective diameter 250 mm or higher. Refer to their operator's manuals for details.

\*\* : Junction boxes are required for more than 100 m antenna cable.

\*\*\* : Contact output for Alarm

(Load current) 120 mA (Polarity) No.1, 2: Normally Close, No.3, 4: Normally Open  
 Serial I/O for alarm is also possible, which complies with IEC 61162-1.



# 1. MOUNTING

## NOTICE

Do not apply paint, anti-corrosive sealant or contact spray to coating or plastic parts of the equipment.

Those items contain organic solvents that can damage coating and plastic parts, especially plastic connectors.

## 1.1 Antenna Unit

### Mounting considerations

- The antenna unit is generally installed either on top of the wheelhouse or on the radar mast, on a suitable platform. Locate the antenna unit in an elevated position to permit maximum target visibility.
- A line of sight from the antenna unit to the bow of the ship should hit the surface of the sea in not more than 500 m or twice the ship's length, depending which value is smaller, for all load and trim conditions.

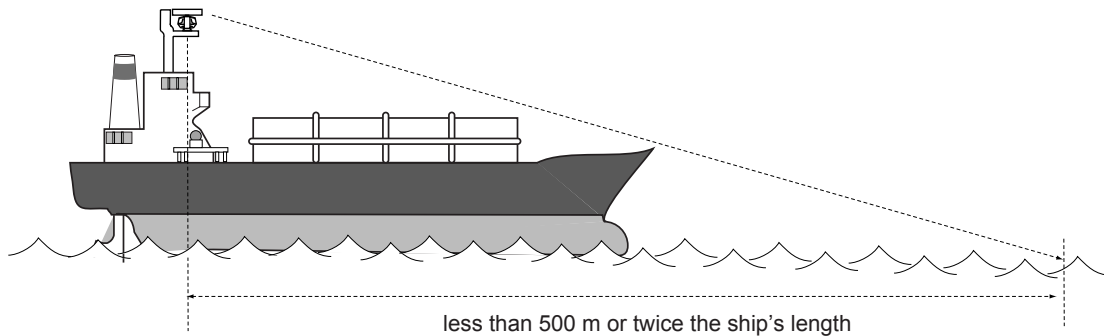

- Mount the antenna unit so that any blind sectors caused by objects (mast, etc.) are kept to a minimum. No blind sector should exist in arc of the horizon from right ahead to 22.5° aft of the beam to either side (see Figure 1 below). Also, individual blind sectors of more than 5°, or the total arc of both blind sectors of more than 20°, should not occur in the remaining arc (Figure 2). Note that any two blind sectors separated by 3° or less are regarded as one sector.

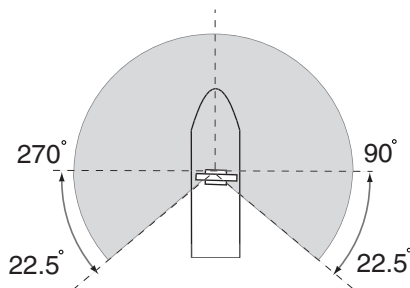

Figure 1

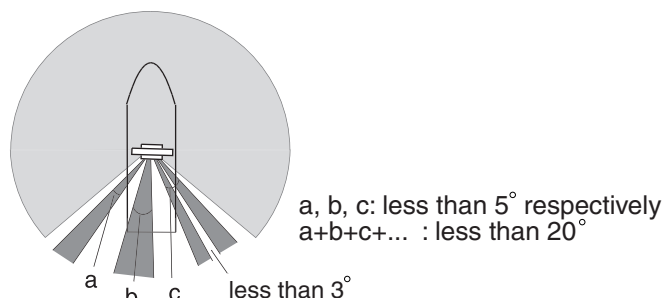
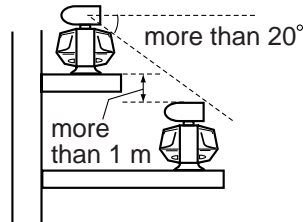

Figure 2

## 1. MOUNTING

- Install the antenna unit away from interfering high-power energy sources and other transmitting radio antenna.
- Keep the lower edge of the antenna unit above the safety rail by 500 mm or more.
- Two antenna units should be mounted as below:



- No funnel, mast or derrick should be within the vertical beamwidth of the antenna unit in the bow direction, especially zero degrees  $\pm 5^\circ$ , to prevent blind sectors and false echoes on the radar picture.
- It is rarely possible to place the antenna unit where a completely clear view in all directions is available. Thus, you should determine the angular width and relative bearing of any shadow sectors for their influence on the radar at the first opportunity after fitting.
- Locate a direction finder antenna clear of the antenna unit to prevent interference to the direction finder. A separation of more than two meters is recommended.
- A magnetic compass will be affected if the antenna unit is placed too close to the magnetic compass. Observe the compass safe distances on page ii to prevent deviation of the magnetic compass.
- Do not paint the radiator aperture, to ensure proper emission of the radar waves.
- The antenna base is made of cast aluminum. To prevent electrolytic corrosion of the antenna base, use the seal washers and corrosion-proof rubber mat and ground the unit with the ground wire (supplied).
- Deposits and fumes from a funnel or other exhaust vent can adversely affect the aerial performance and hot gases may distort the radiator portion. The antenna unit must not be mounted where the temperature is more than  $55^\circ\text{C}$ .
- Leave sufficient space around the unit for maintenance and servicing. See the antenna unit outline drawing for recommended maintenance space.

## Assembling the antenna unit

The antenna unit consists of the antenna radiator and the antenna unit chassis, and they are packed separately. Fasten the antenna radiator to the antenna unit chassis as follows:

1. For the XN20AF, XN24AF, attach two guide pins to the underside of the antenna radiator.
2. Remove the waveguide cap from the radiator bracket. The cap may be discarded.
3. Coat the waveguide flange with anticorrosive sealant as shown below.

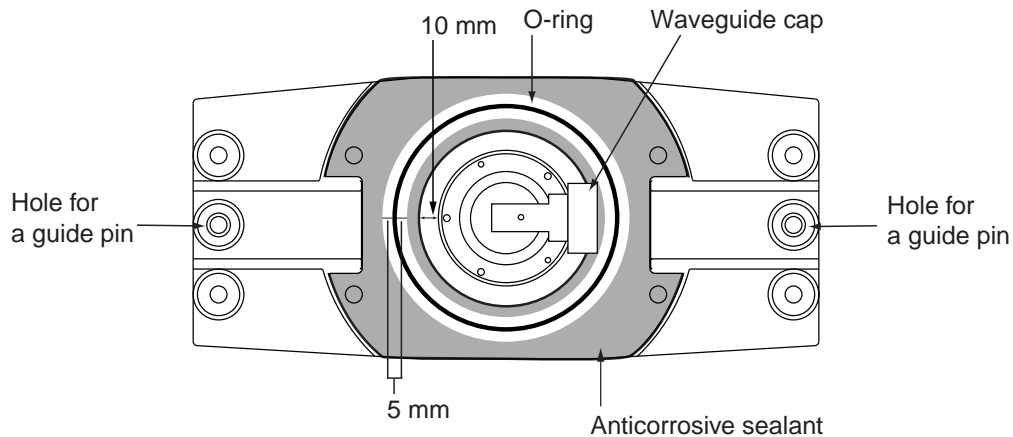

*Coating the waveguide flange with anticorrosive sealant*

4. Coat fixing holes for the antenna radiator with anticorrosive sealant.
5. Grease the O-ring and set it to the O-ring groove of the radiator flange.
6. Set the antenna radiator to the radiator bracket.
7. Coat hex bolts M8x40 (for XN-20AF or XN-24AF) or hex bolt M8x35/ flat washer/spring washer (for XN-12AF) with anticorrosive sealant and use them to loosely fasten the antenna radiator to the antenna unit chassis.
8. Remove two guide pins (inserted at step 1), and then tighten fixing bolts.

### **CAUTION**

**Be sure to remove the guide pins.**

Injury may result if the guide pins loosen and fall.

## 1. MOUNTING

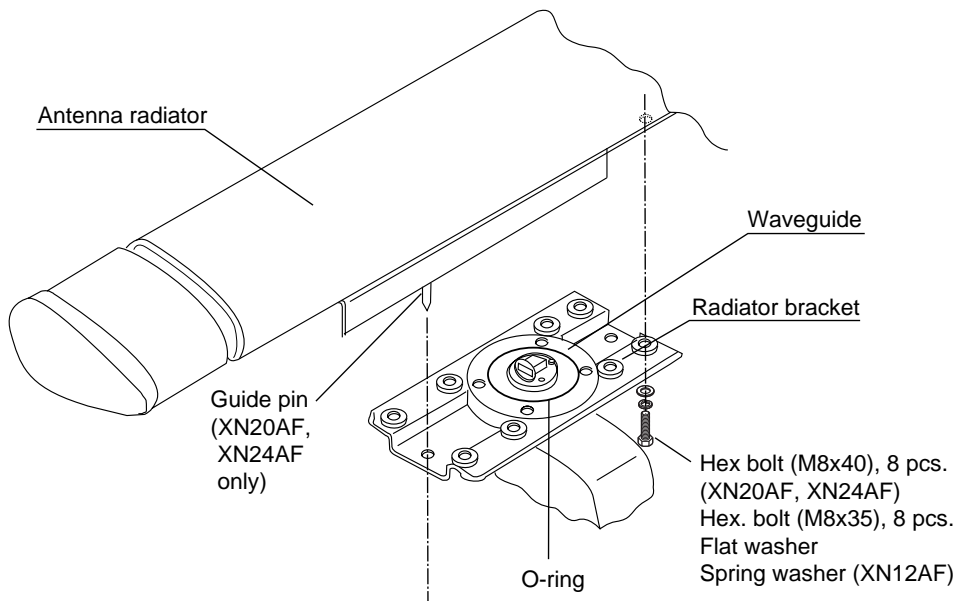

### *Fastening the radiator to the radiator bracket*

## Fastening the antenna unit to the mounting platform

The antenna unit may be assembled before hoisting it to the mounting platform. However, do not lift the antenna unit by the radiator. Always hold the unit by its housing. When using a crane or hoist, lift the unit by the hoist rings which should be fastened to the bolt fixing covers of the antenna housing.

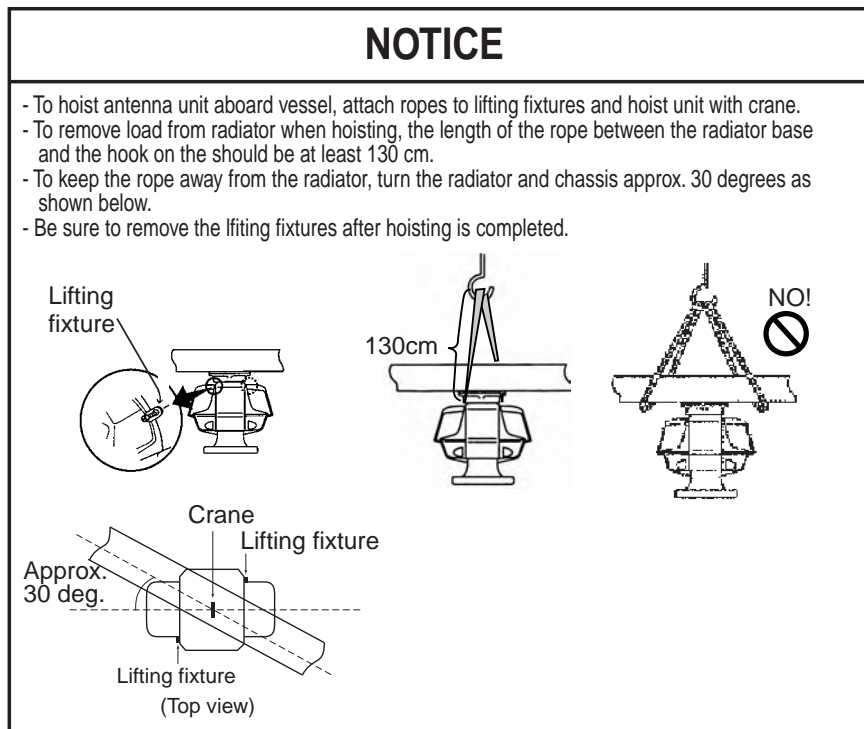

1. Construct a suitable mounting platform referring to the outline drawing at the end of this manual.
2. Drill four mounting holes of 15 mm diameter and one cable entry hole of about 50 mm diameter in the mounting platform.
3. Lay the rubber mat (supplied) on the mounting platform.
4. Place the antenna unit on the rubber mat, orienting the unit so the bow mark on its base

- Place the antenna unit on the rubber mat, orienting the unit so the bow mark on its base is facing the ship's bow.

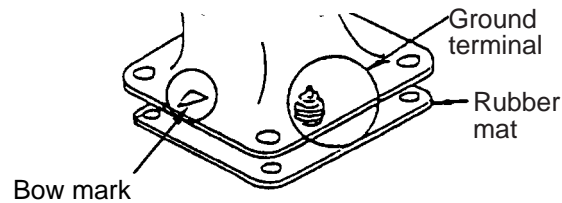

*Antenna unit, front view*

- Fasten the antenna unit to the mounting platform with M12x60 hex bolts, nuts, flat washers and seal washers.
- Using hex bolt (M6x25), nut (M6) and flat washer (M6), establish the ground system on the mounting platform as shown below. The location should be within 340 mm of the ground terminal on the antenna unit. Connect the ground wire (RW-4747, 340 mm, supplied) between the grounding point and ground terminal on the antenna unit. Coat the entire ground system with silicone sealant (supplied).

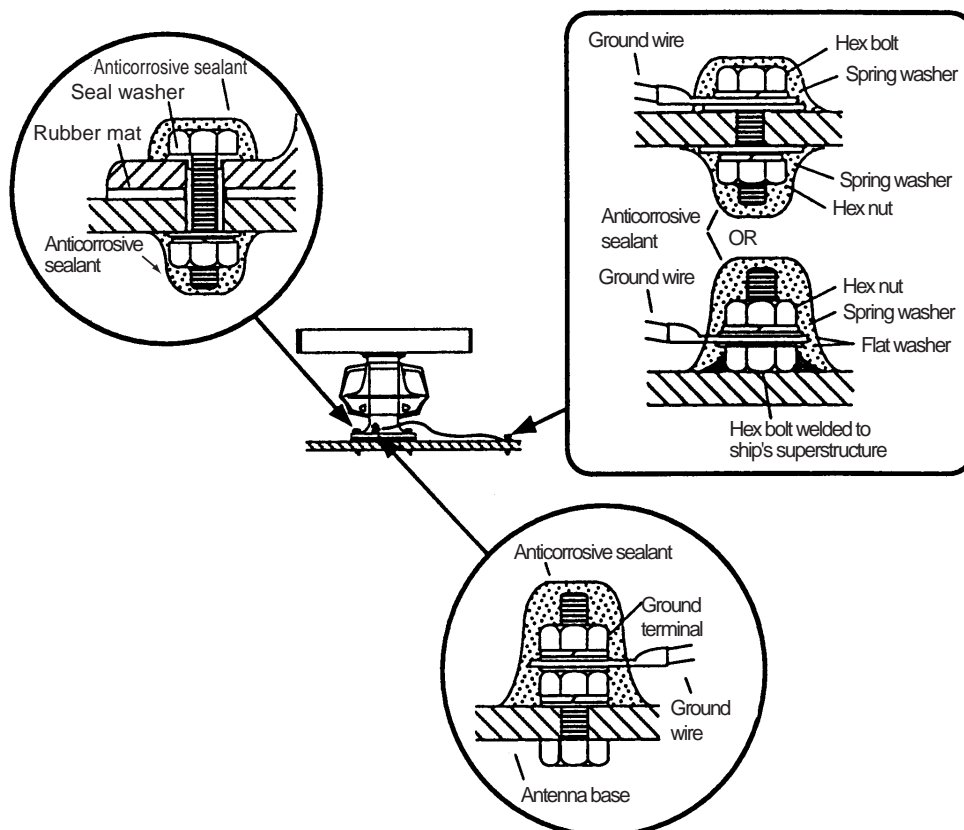

*How to mount the antenna unit*

## 1.2 Monitor Unit

The monitor unit can be flush mounted in a console panel, or mounted on a desktop using the optional accessories. For MU-190/231, see the applicable Operator's Manual(s).

**Note:** FAR-2117-BB/2127-BB have no monitor unit. Prepare a suitable monitor locally.  
 Recommended monitor: SXGA (1280x1024), aspect ratio 5:4

### Mounting considerations

When selecting a mounting location, keep in mind the following points:

- Select a location where the display unit can be viewed conveniently and where the screen can be viewed while facing towards the bow.
- The optimal viewing distances for the radar display units are: MU-170C: 920 mm, MU-201CR: 1080 mm, MU-231CR: 1200 mm. Select a suitable mounting location considering the applicable distance.
- Locate the unit out of direct sunlight and away from heat sources because of heat that can build up inside the cabinet.
- Locate the equipment away from places subject to water splash and rain.
- Leave sufficient space on the sides and rear of the unit to facilitate maintenance.
- A magnetic compass will be affected if the monitor unit is placed too close to the magnetic compass. Observe the compass safe distances on page ii to prevent deviation of a magnetic compass.

### Mounting procedure

#### Flush mounting

Follow the procedure below to mount the monitor unit in a console panel.

1. Make cutout in mounting location referring to the outline drawing shown below.
2. Insert the monitor unit to the hole and fix it with four tapping screws (6x30).
3. Attach panel hooks near the fixing holes (upper part). See next page. These are used to pull out the monitor unit from a console panel for servicing.
4. Attach four panel covers to the fixing holes.

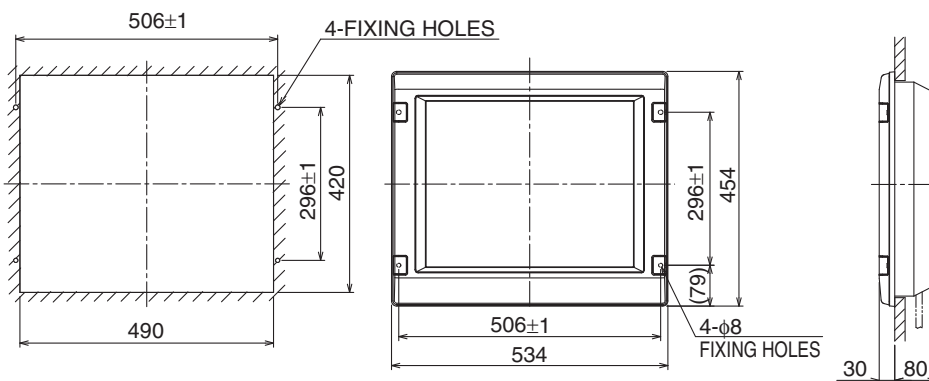

Monitor unit MU-201CR  
 (For FAR-2117/2127)

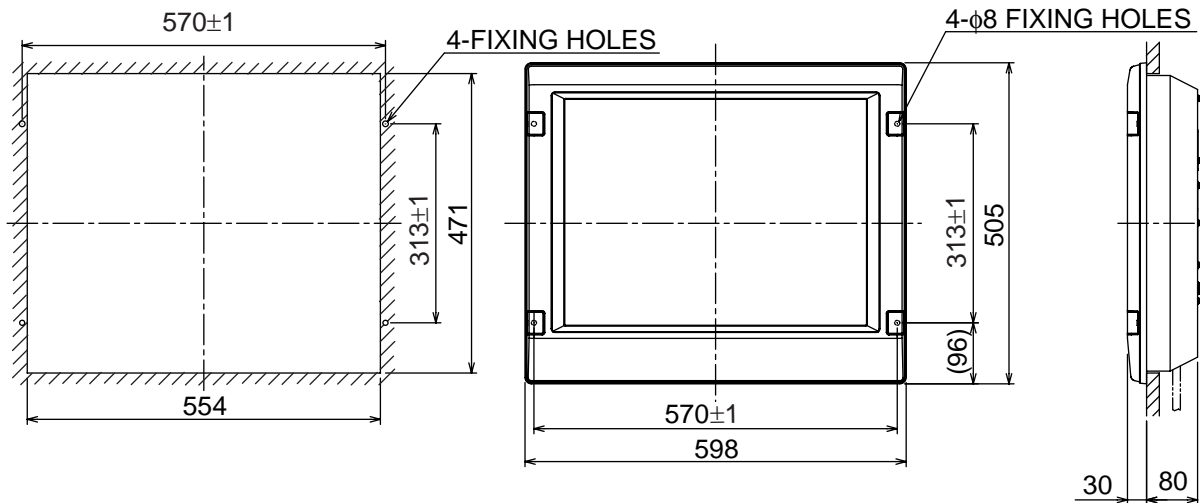

Monitor unit MU-231CR  
(For FAR-2817/2827)

*Flush mounting of monitor unit*

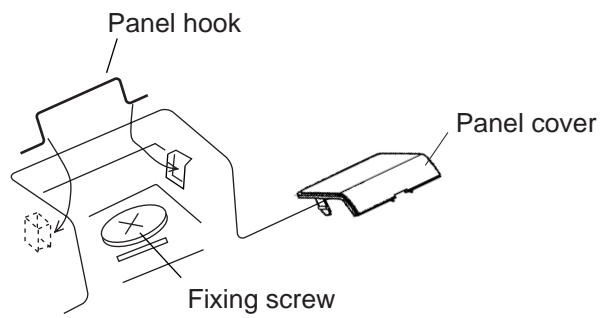

*Attaching panel hook and panel cover*

**Note:** If you need to remove the monitor unit from the mounting panel, remove the four panel covers with your fingernail and use two panel hooks supplied as accessories to lift the monitor unit.

## 1. MOUNTING

### **Desktop mounting**

Use the optional accessories to mount the monitor unit on a desktop.

- For FAR-2117/2127: FP03-09820 (Code No.: 008-535-560)
- For FAR-2817/2827: FP03-09830 (Code No.: 008-536-020)

#### *Contents of FP03-09820/09830*

Name	Type	Code No.	Qty	Remarks
Hanger L	03-163-1111	100-305-141	1	
Hanger R	03-163-1112	100-305-181	1	
Hanger stay	03-163-1113	100-305-191	1	For FAR-2117/2127
	03-163-2071	100-305-371		For FAR-2817/2827
Hole plug	CP-30-HP-13	000-160-074-10	2	
Plastic rivet	KB-13 Rivet Black	000-570-276-10	4	
Hex. bolt	M6x25	000-162-949-10	4	
Hex. bolt	M10x30	000-162-884-10	2	
Spring washer	M10	000-864-261	2	
Flat washer	M10	000-864-131	2	

1. Assemble two hangers and hanger stay with two hex bolts (M10x30), flat washers and spring washers and cover each hex bolt with hole plug.
2. Fix the above assembly to the mounting location with four hex bolts (M12, dockyard supply).
3. Fasten the monitor unit to the mounting hanger assembly with four hex bolt (M6x25, supplied).
4. Cover each hex bolts with panel cover.
5. Cover each holes for hand grip on the hangers with plastic rivets (4 pcs).



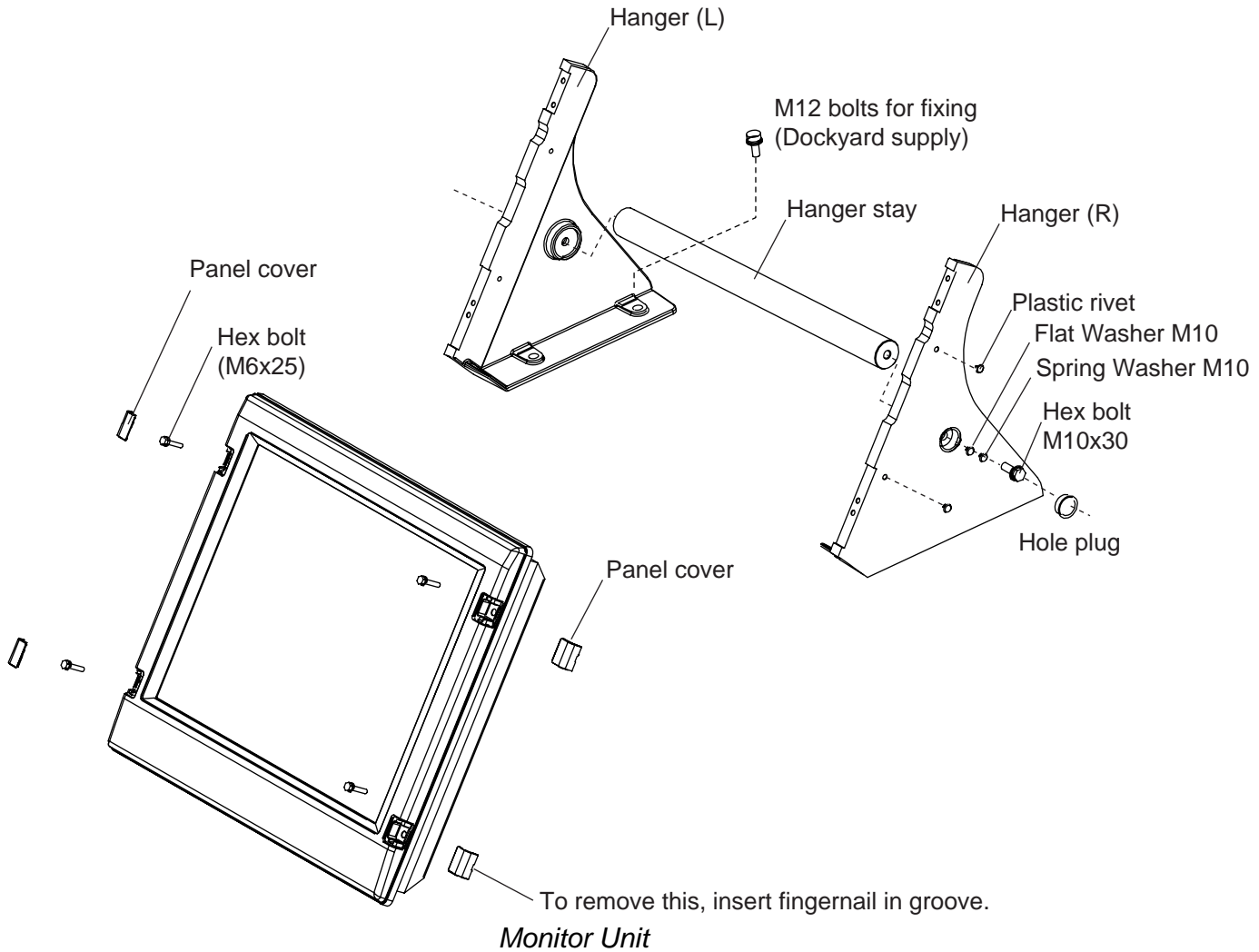

- The hand grip is optionally available for the desktop mounting monitor unit.

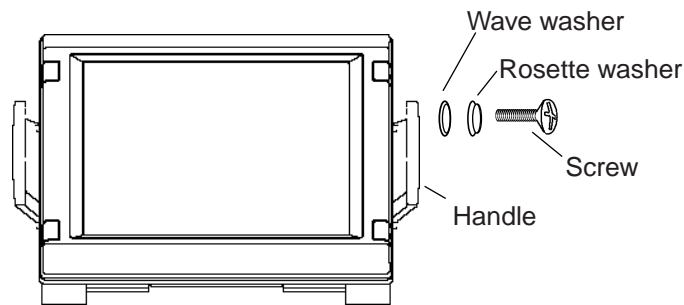

**Hood (option)**

When it is too bright in the daytime, use the optional hood to shade the screen.

- For FAR-2117/2127: FP03-11500 (Code No.: 001-020-090)
- For FAR-2817/2827: FP03-11000 (Code No.: 008-571-680)

Contents of hood

Name	Type	Code No.	Qty.	Remarks
Hood (21)	FP03-11501	001-020-120	1	For FAR-2117/2127
Hood (23)	FP03-11001	008-571-700	1	For FAR-2817/2827
Fixing plate	03-163-2202-0	100-335-560-10	4	
Screw	M4x10 D=13 US304	000-862-543	4	

## 1. MOUNTING

1. **Desktop mounting:** Fasten the fixing plates to the fixing holes with the hex head bolts (supplied).

**Flush mounting:** Fasten the display unit to the mounting location, and then attach the fixing plates with four self-tapping screws.

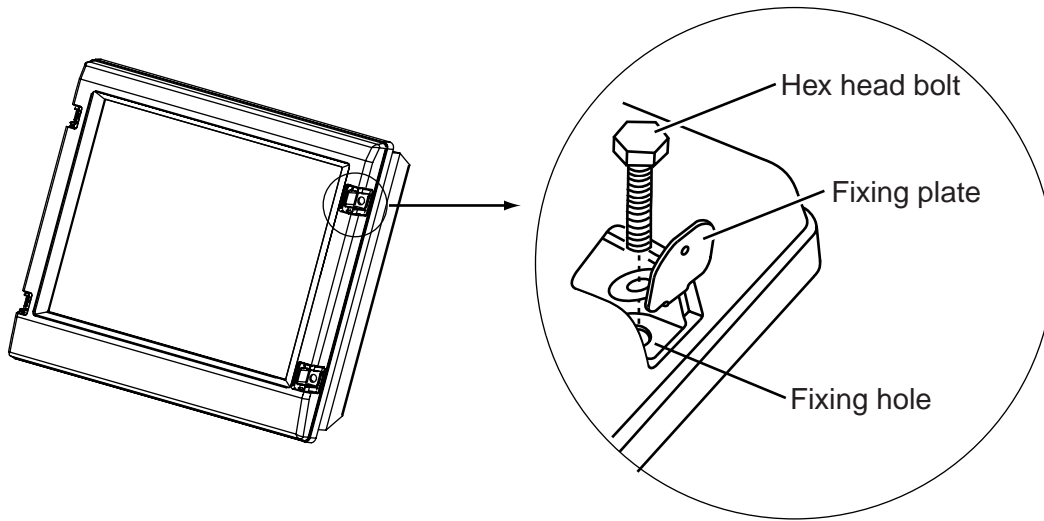

2. Attach the hood to the display unit (the hood is outside of the fixing plates).

3. Fasten the hood to the fixing plates with four screws supplied (M4x10).

### 1.3 Control Unit

The control unit may be mounted on a desktop, with or without the KB fixing metal (supplied), which mounts the control unit at an angle.

#### Mounting considerations

When selecting a mounting location, keep in mind the following points:

- Select a location where the control unit can be operated conveniently.
- Locate the unit away from heat sources because of heat that can build up inside the cabinet.
- Locate the equipment away from places subject to water splash and rain.
- Determine the mounting location considering the length of the signal cable between the control unit and the processor unit. (The 10m signal cable is attached to the control unit).
- A magnetic compass will be affected if the control unit is placed too close to the magnetic compass. Observe the compass safe distances on page ii to prevent deviation of a magnetic compass.

**Fixing with KB fixing plate**

1. Fix the KB fixing plate to the bottom of the control unit.
2. Attach cushions (three for RCU-014, two for RCU-015/016) to the bottom of the control unit as shown below.
3. Fix it to a desired location with self-tapping screws (local supply).

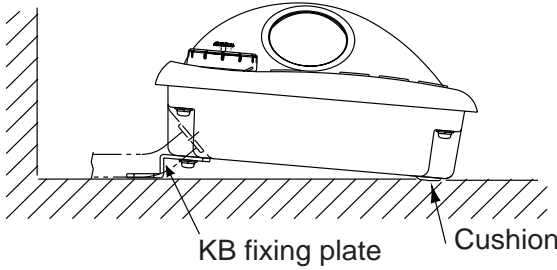

Side view for RCU-014/015/016

**Fixing without KB fixing metal**

1. Drill four mounting holes of 5 mm diameter referring to the outline drawing at the back of this manual.
2. Fix the control unit with four screws (M4) from under side of the desktop. (The M4 screws with a sufficient length for the thickness of the desktop should be provided locally.)

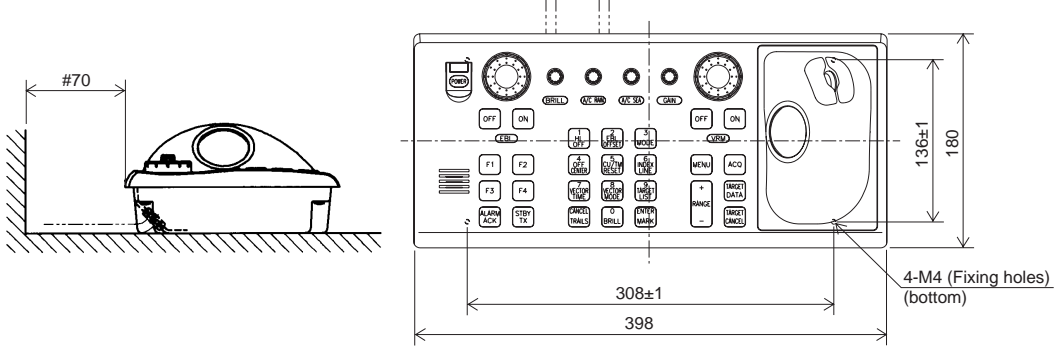

Control Unit RCU-014

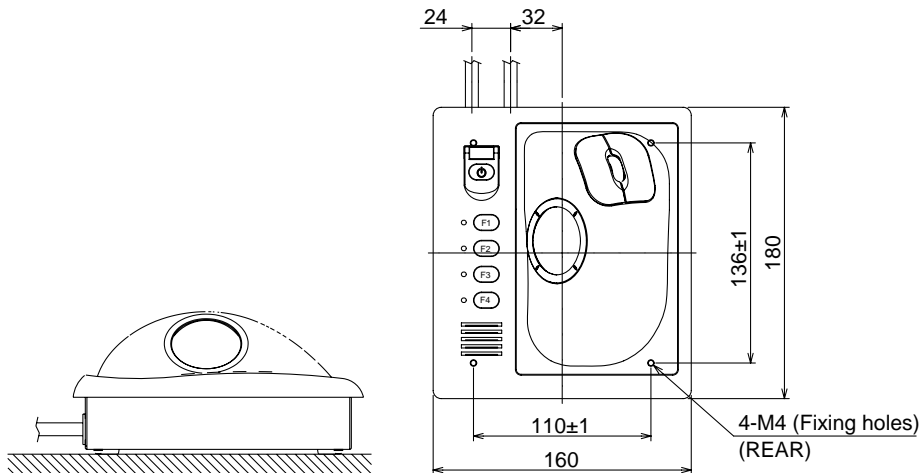

RCU-015/016

## 1. MOUNTING

### **Flush mounting**

Use the optional flush mount kit FP03-09870 to mount the control unit RCU-014, RCU-015 and/or RCU016 to a console panel.

Name: Flush mount kit

Type: FP03-09870

Code No.: 008-535-630

No.	Name	Type	Code No.	Qty
1	Mount plate	03-163-7531	100-306-261	4
2	Hex nut	M5	000-863-108	4
3	Wing screw	M5x40	000-162-682-10	4
4	Pan head screw	M4x12	000-163-192-10	4

1. Prepare a cutout in the mounting location as shown in the figure below.

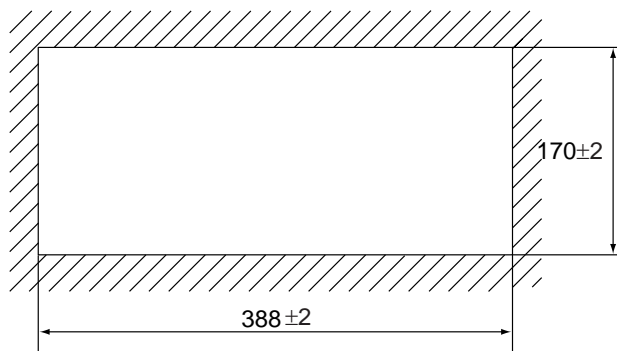

*For RCU-014*

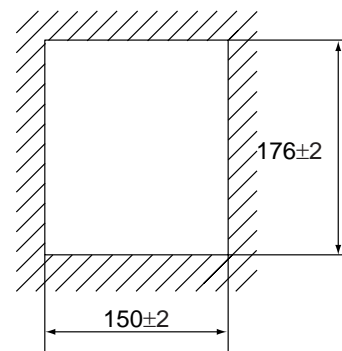

*For RCU-015 and RCU-016*

2. Set the control unit to the cutout.
3. Attach the mounting plate to the control unit with four screws from the rear side.
4. Screw the wing screw to each mounting plate and then insert hex bolt to each wing screw.
5. Fasten each wing screw and then fasten the hex nuts as shown in the figure below.

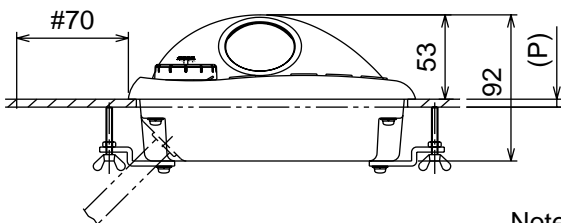

*RCU-014*

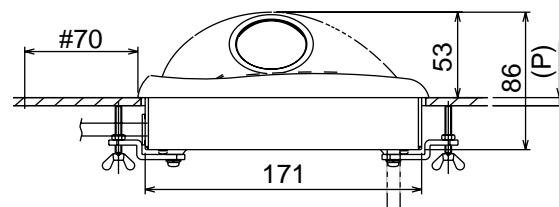

*RCU-015/RCU-016*

Note:  $P \leq 10$

**To connect RCU-016 in series with RCU-014**

1. Pass the cable derived from RCU-016.

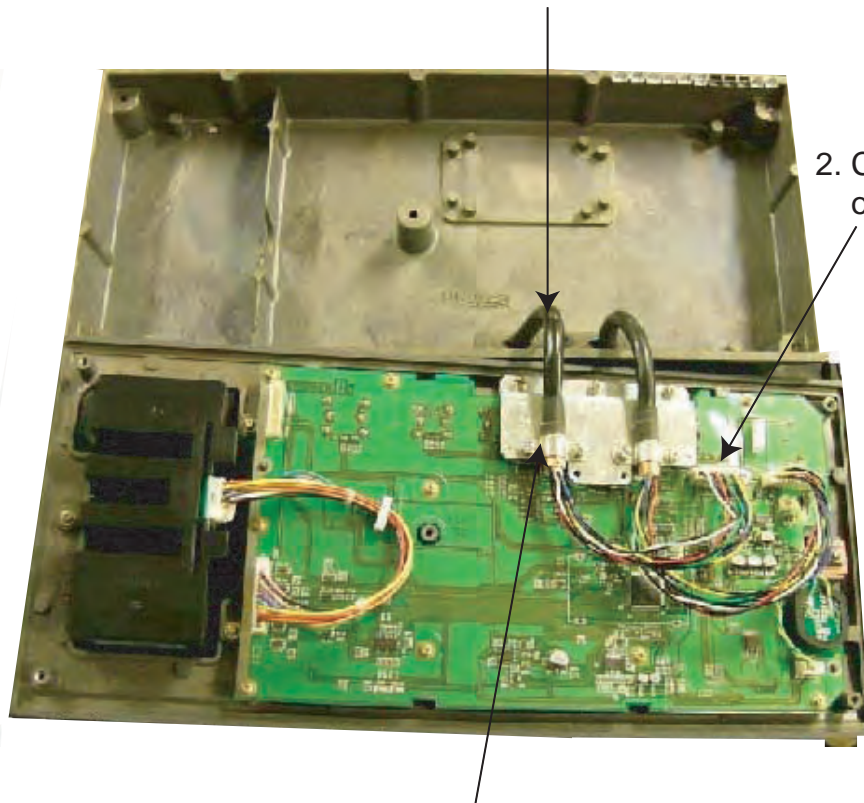

2. Connect the connector of the cable to J502.

3. Clamp the copper part of the cable with the cable clamp.

*Inside of RCU-014*

# 1. MOUNTING

## To change the cable entry

To change the cable entry from the side (default) to the bottom, modify the unit as shown below.

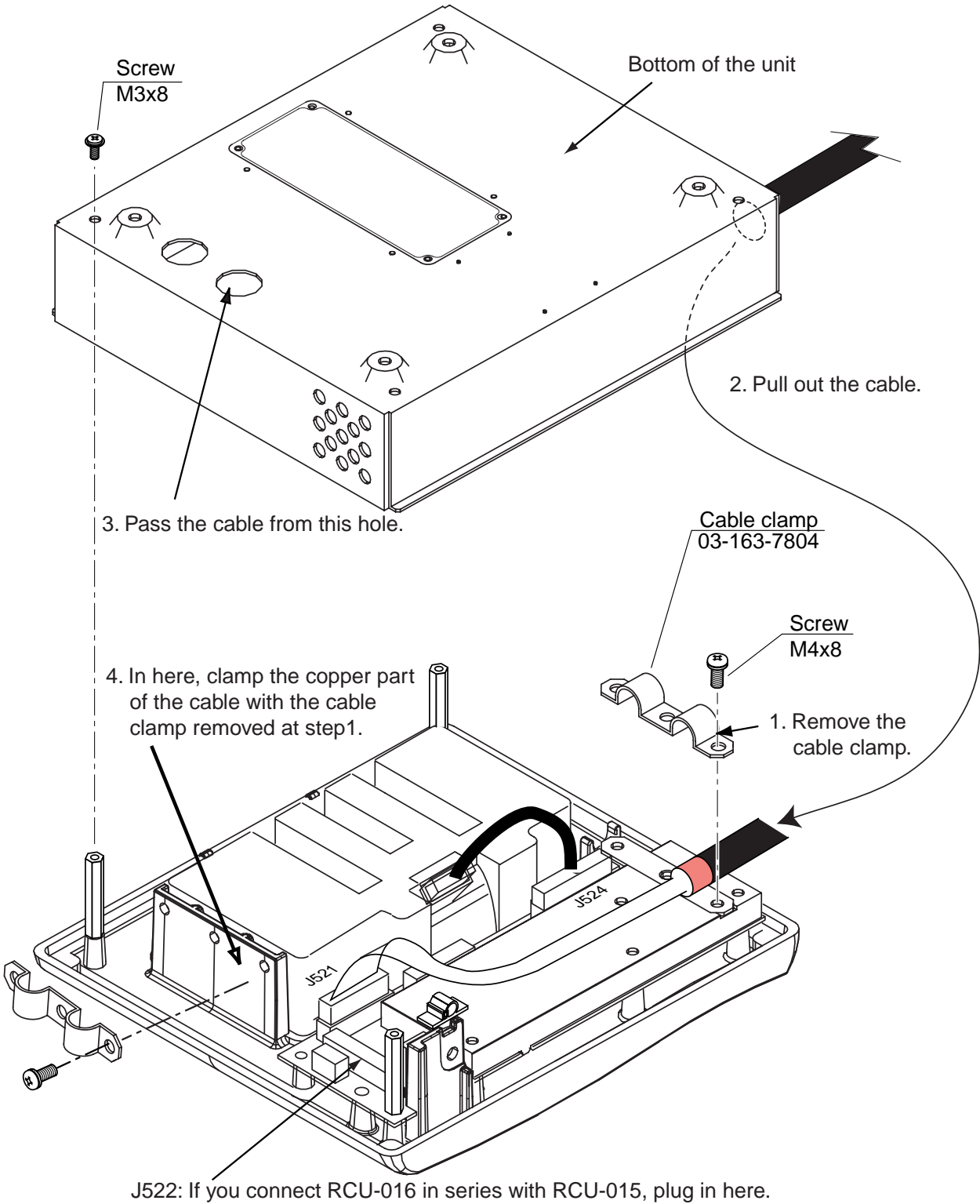

*RCU-015/016: Changing cable entry*

## 1.4 Processor Unit

### Mounting considerations

When selecting a mounting location, keep in mind the following points:

- Locate the processor unit away from heat sources because of heat that can build up inside the cabinet.
- Locate the equipment away from places subject to water splash and rain.
- Leave sufficient space at the sides and rear of the unit to facilitate maintenance.
- A magnetic compass will be affected if the processor unit is placed too close to the magnetic compass. Observe the compass safe distances on page ii to prevent deviation of a magnetic compass.

### Mounting procedure

1. Fix the unit with four M6 bolts, or self-tapping screws.

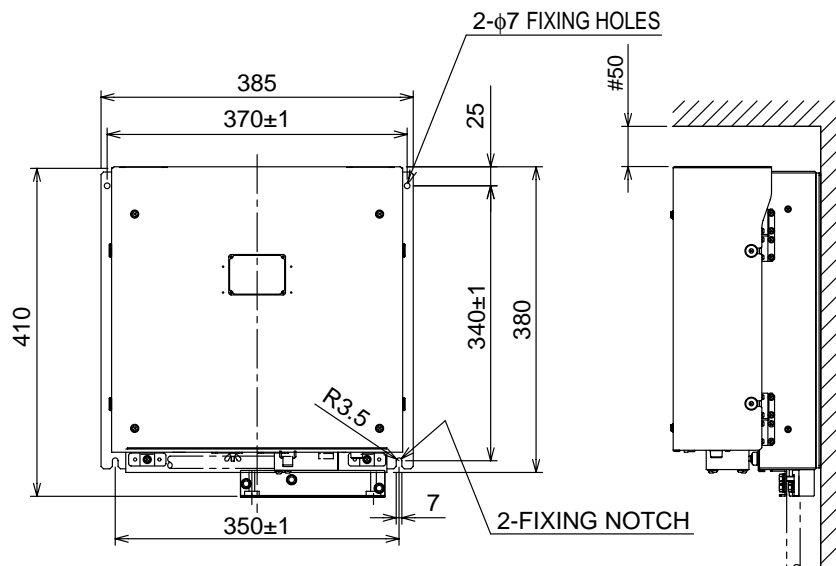

*Floor mounting or bulkhead mounting*

**Note:** If you fix the unit, cable entry upside, never remove the screw M3x10 that joints the upper case assy. and lower case assy. of the processor unit.

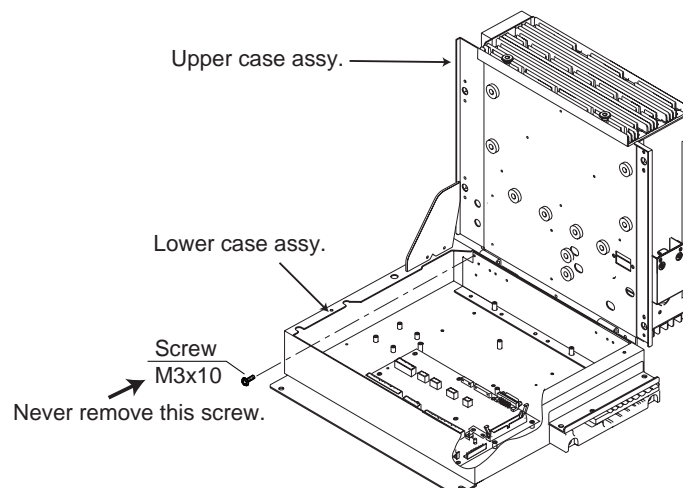

*Processor unit*

## 1. MOUNTING

*This page is intentionally left blank.*



# 2. WIRING

## Wiring consideration

- To lessen the chance of picking up electrical interference, avoid where possible routing the signal cable near other onboard electrical equipment (radars, transmitting radio antennas, etc.) Also avoid running the cable in parallel with power cables. When crossing with other cable, the angle should be 90° to minimize the magnetic field coupling.
- The signal cable run between the antenna and processor units is available in lengths of 15 m (standard), 30 m and 50 m. Whatever length is used it must be unbroken; namely, no splicing allowed. Use the signal cable as short as possible to minimize attenuation of the signal.
- The radar should be connected to an emergency power source, as required by SOLAS II-1.

## 2.1 Interconnection

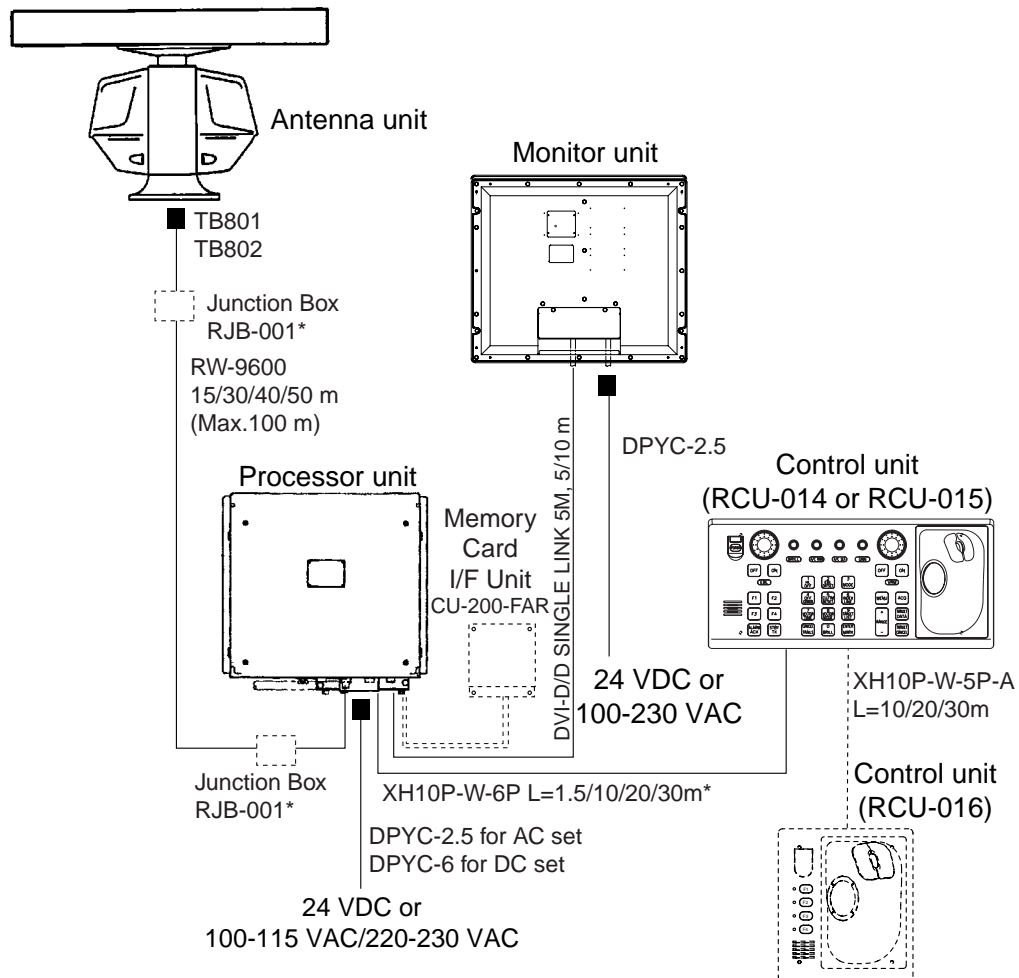

\*: If the length of the antenna cable is more than 100m, use Junction box RJB-001. However, the maximum length is 300m.

■ : Cable requires fabrication

*Standard Interconnection*

## 2.2 Antenna Unit

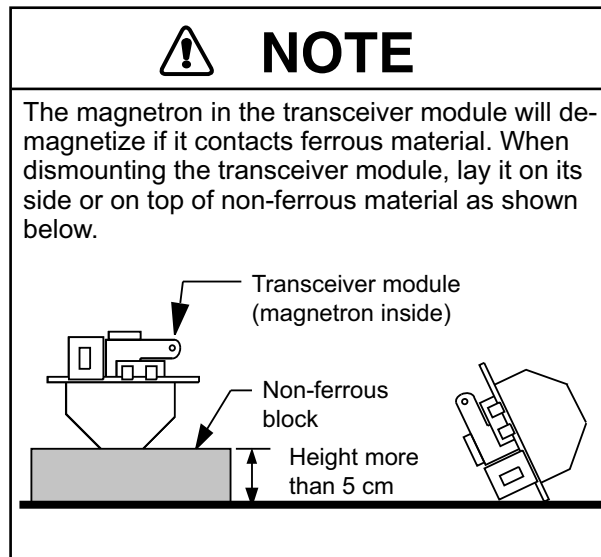

1. Open the rear cover of the antenna unit
2. Disconnect plugs P823, P803, P831 and P921. If the PM-31 is installed, also disconnect plug P911.
3. Unfasten two bolts and remove the transceiver module.

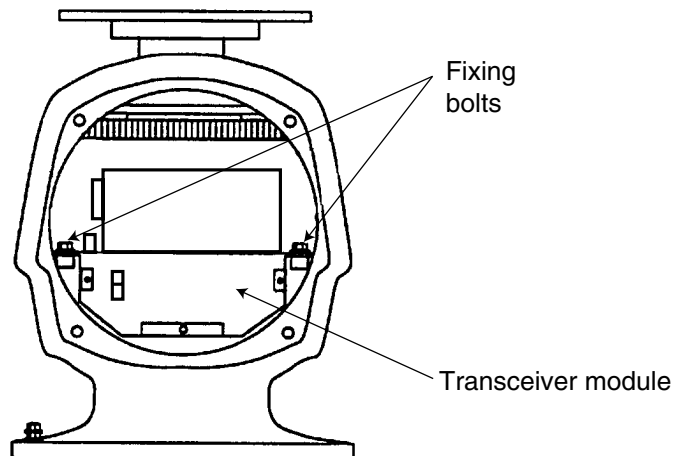

*Antenna unit, rear view*

4. Unfasten the four fixing bolts from the cable gland at the base of the antenna unit. Remove clamping ring, rubber gasket and washers.
5. Pass the signal cable through the cable entry hole in the antenna unit mounting platform. Trim the cable so about 80 cm of it protrudes past the cable gland.

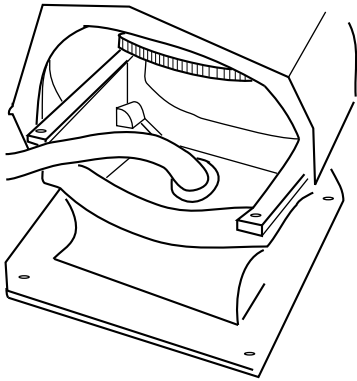

Antenna unit, front view, cover removed

6. Fabricate the signal cable RW-9600 as shown below.
  - a) Remove the outer vinyl sheath, by about 500 mm, then armor and inner sheath by about 470mm.
  - b) Unravel the shield to expose the core wires.
  - c) Trim each core wire (except coaxial wire) considering its location on the terminal board.
  - d) Trim the shield leaving about 500 mm and attach crimp-on lug FV5.5-4 (yellow,  $\phi 4$ ).
  - e) Remove insulation of each wire by about 6 mm.

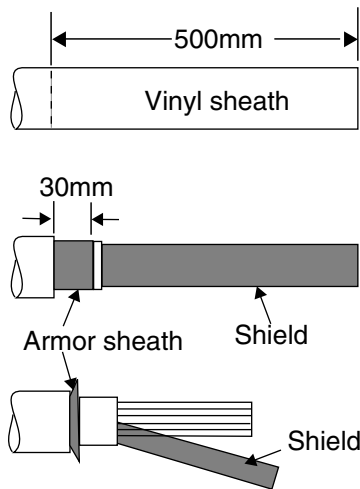

7. Slide a washer, and fold back armor. Slide a washer, rubber gasket, washer, and clamping ring in order. Cut the armor around the washer so it is level with the washer.

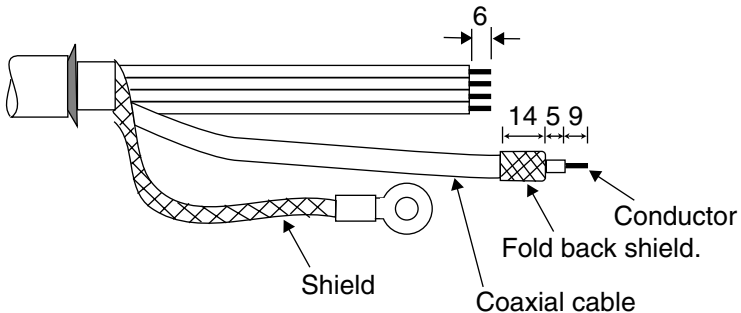

## 2. WIRING

8. Nip the armor between two washers, and trim the excess armor from around washers. And then pass the shield between the clamping ring and the washer as shown below. Fasten the clamping ring with the screws.

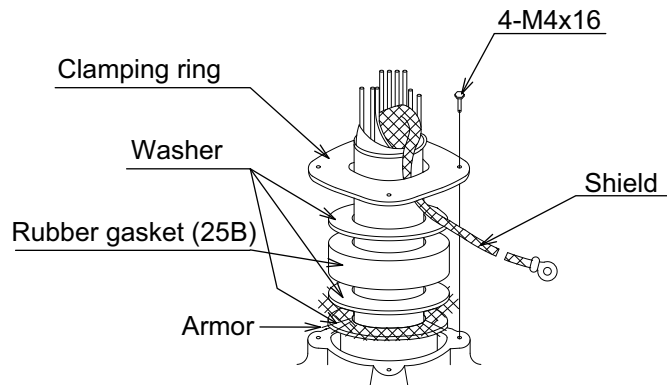

*Signal cable entrance*

9. Connect the signal cable to the terminal board TB801 and TB802 on the RFTB board 03P9349 by referring to the interconnection diagram. Keep "slack" in the coaxial wire to prevent breakage. Insert the cores (except coaxial wire) to the connector with the opener.

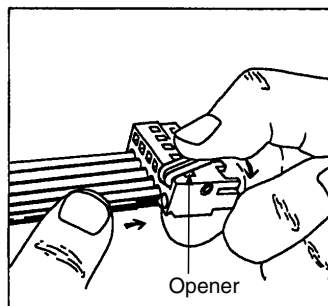

1. Insert opener.
2. Push opener.
3. Insert a core.
4. Release opener.

Clamp the coaxial wire with cable clamp on the board 03P9349 as shown below.

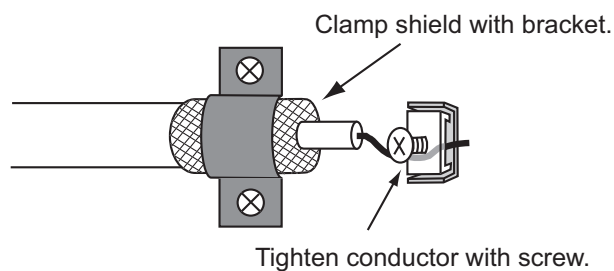

10. Bind cable cores with cable ties.

11. Set the transceiver module to the antenna unit, push it in until it stops, and then tighten fixing bolts (4 pcs.). Connect plugs P823, P803, P831, P921 and J911 (if installed). Fasten the shield wire to the wing nut on the transceiver module.

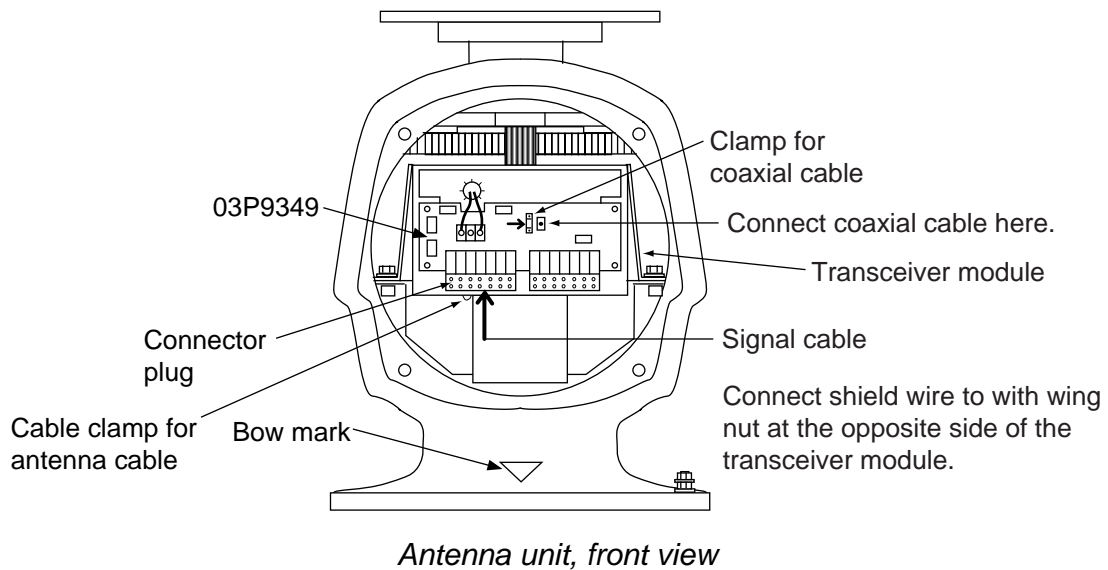
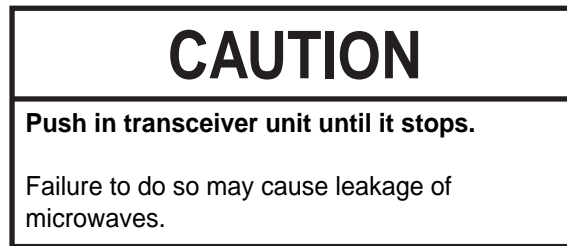

12. Confirm that all screws are tightened and all wiring is properly made. Confirm that waterproofing gasket, bolts and tapping holes of antenna unit are coated with silicone grease. Close the antenna unit cover (torque: 2.5 N·m).

## 2.3 Monitor Unit

Two cables are terminated at the display unit: the signal cable from the processor unit (5 m or 10 m cable) and the power cable from the ship's mains. The signal cable comes with a connector preattached to it for connection to the monitor unit. Fabricate the power cable as below. Use DPYC-2.5 (Japan Industry Standard) cable or the equivalent.

For MU-190/231, see the applicable Operator's Manual(s).

### Fabricating the power cable

1. Cut armor of the cable by 40 mm.
2. Cut vinyl sheath by 35 mm.
3. Remove insulation of wires by about 10 mm. Fix crimp-on lugs to the cores.
4. Peel paint of the armor by 40 mm.
5. Cover the end of armor with vinyl tape.

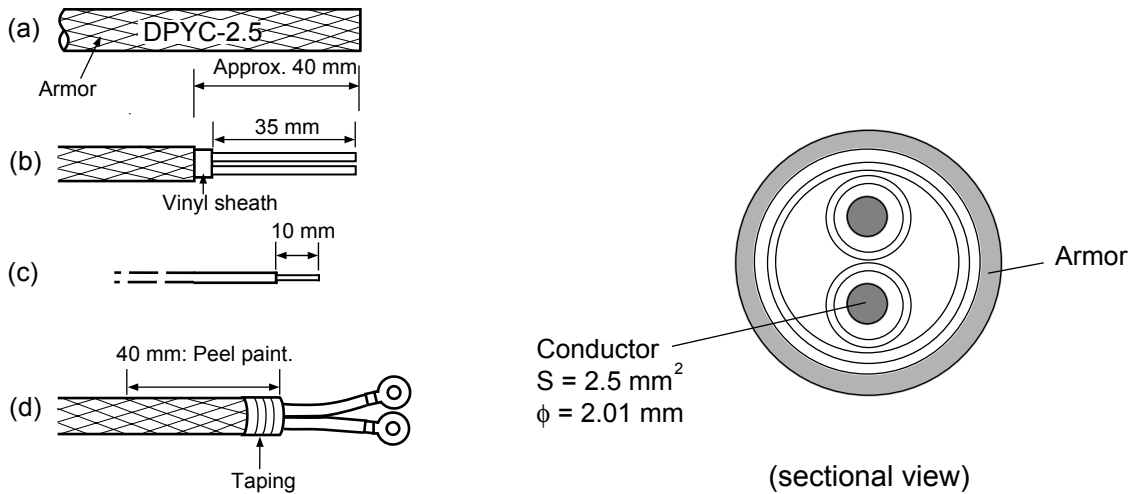

*Fabricating power cable DPYC-2.5*

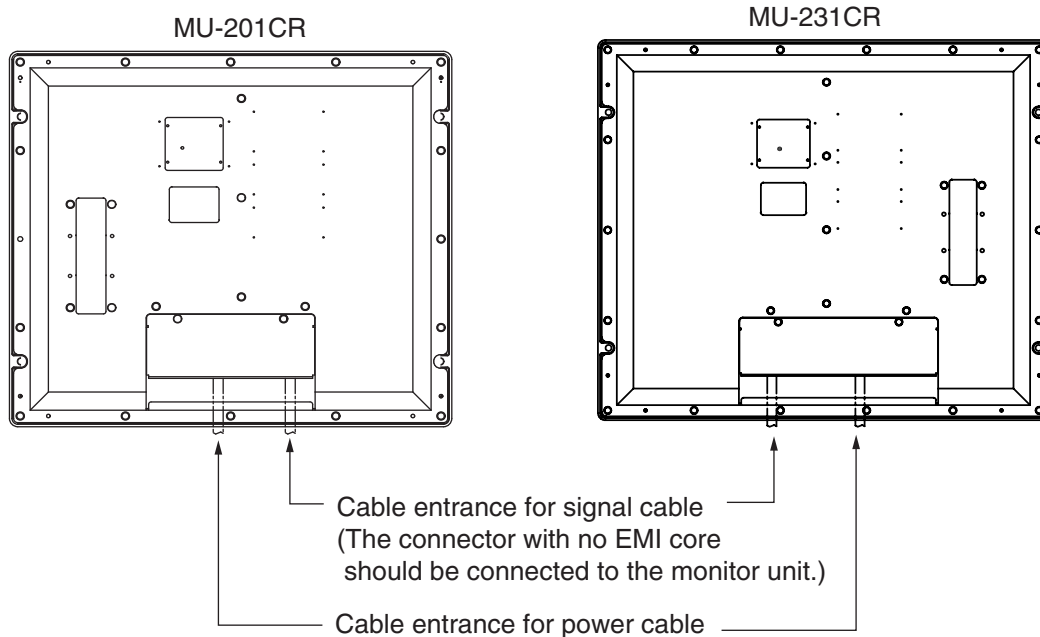

*Monitor unit (rear panel)*

## 2.4 Processor Unit

Four cables are terminated at the processor unit: the antenna unit cable, display unit cable, control unit cable and the power cable. Cables other than the power cable come with a connector preattached to them for connection to the processor unit. Fabricate the power cable as below. For the power cable, use DPYC-2.5 (Japan Industry Standard) cable for AC unit or DPYC-6 for DC unit, or the equivalent.

### Note: For AC unit

Pass the AC line through a double-contact breaker (shipyard supply).

### Fabricating the power cable

1. Cut armor of the cable by 40 mm.
2. Cut vinyl sheath by 35 mm.
3. Remove insulation of wires by about 10 mm. Fix crimp-on lugs to the cores.
4. Peel paint of the armor by 40 mm.
5. Cover the end of armor with vinyl tape.

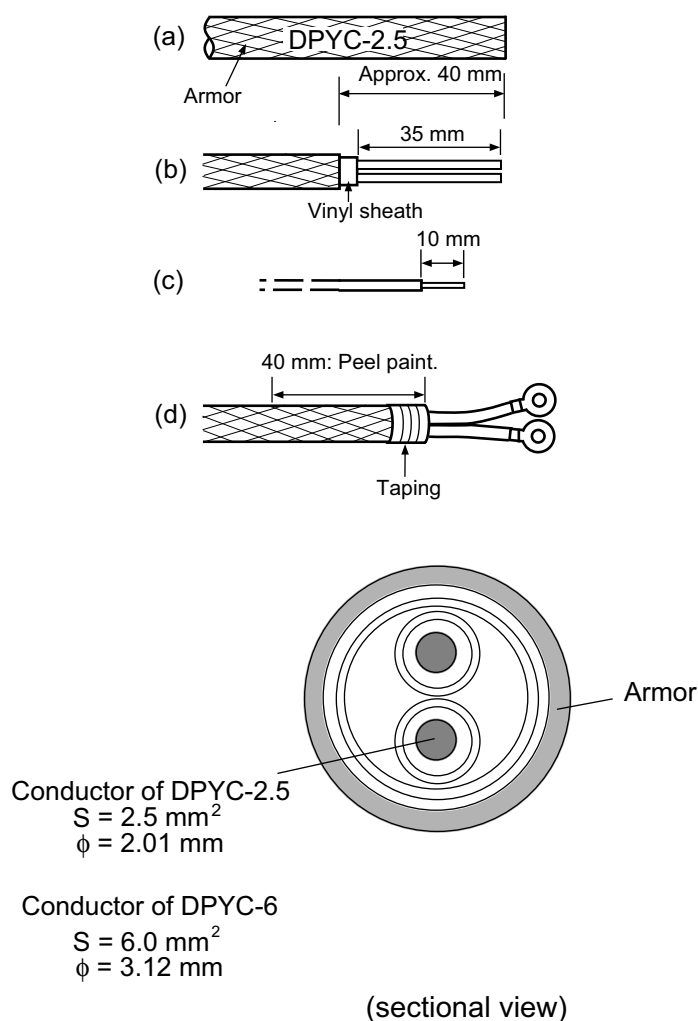

*Fabricating power cable DPYC*

### Connection of cables

The power cable is connected to the terminal board on the rear panel and the signal cable from the monitor unit is connected to the DVI-D connector. Other cables are connected to the printed circuit board 03P9342.

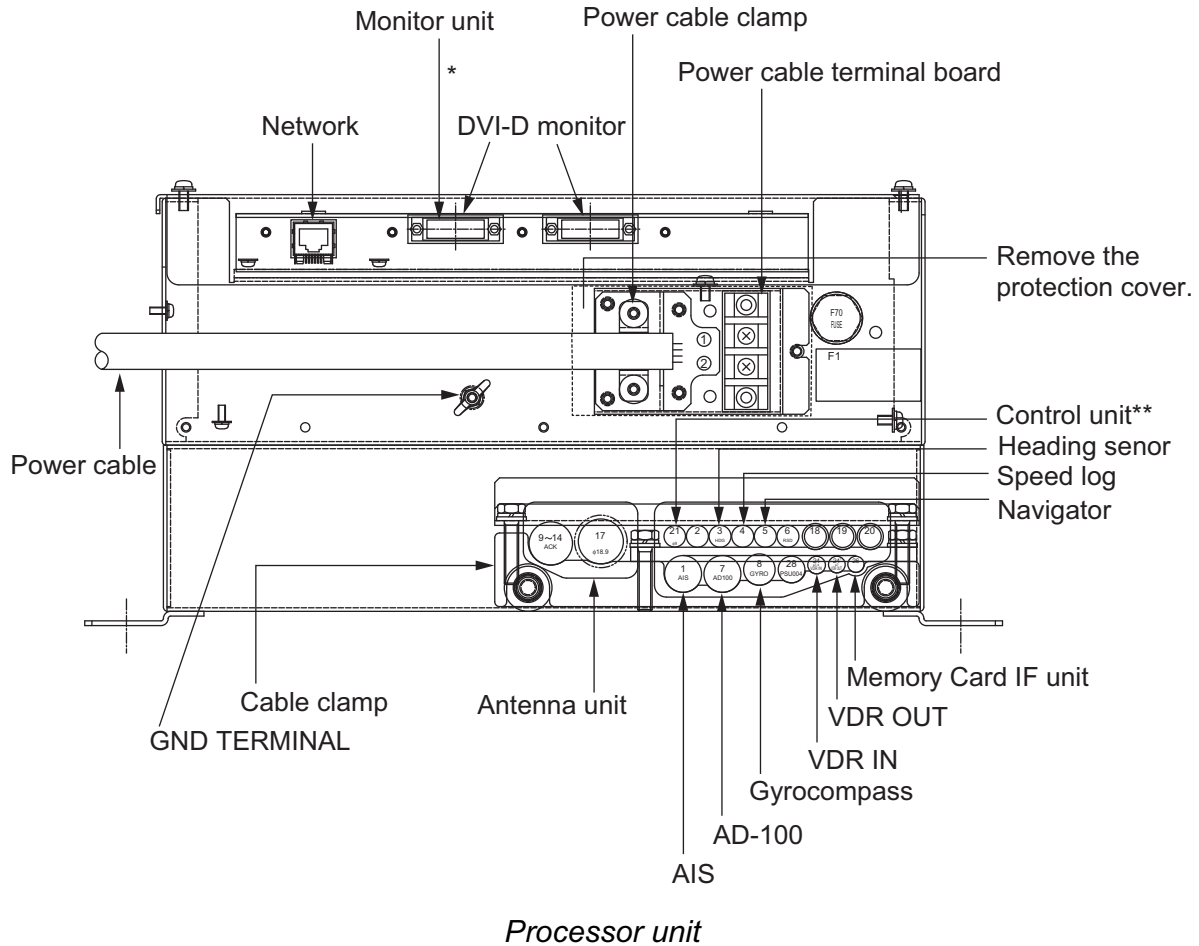

- \*: The connector with EMI core should be connected to the processor unit.
- \*\* : The configuration of optional cable between the processor unit and the control unit is as follows. Note that the cable fabrication for each end is different.

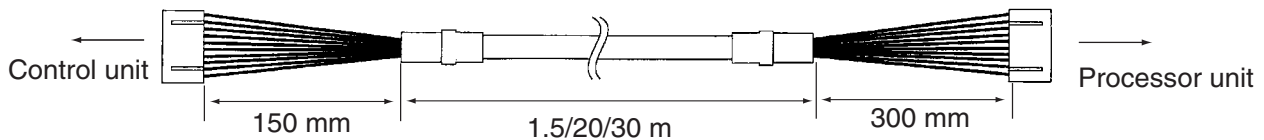

*Cable XH10P-W-6P L=20/30M*

When the RCU-016 is installed, optional cable (XH10P-W-5P-A, L=10/20/30M) is required. Cable fabrication for each end is the same.

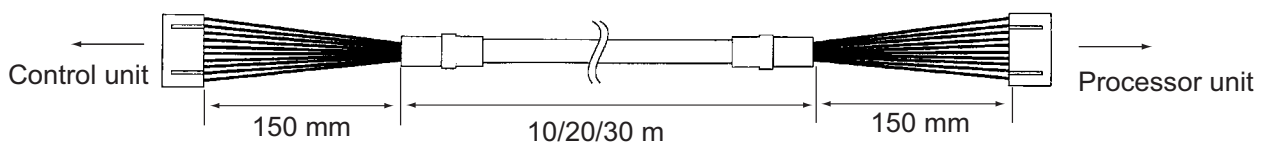

*XH10P-W-5P-A L=10/20/30M*



### Location of connectors

Open the processor unit as follows and the 03P9342 board appears.

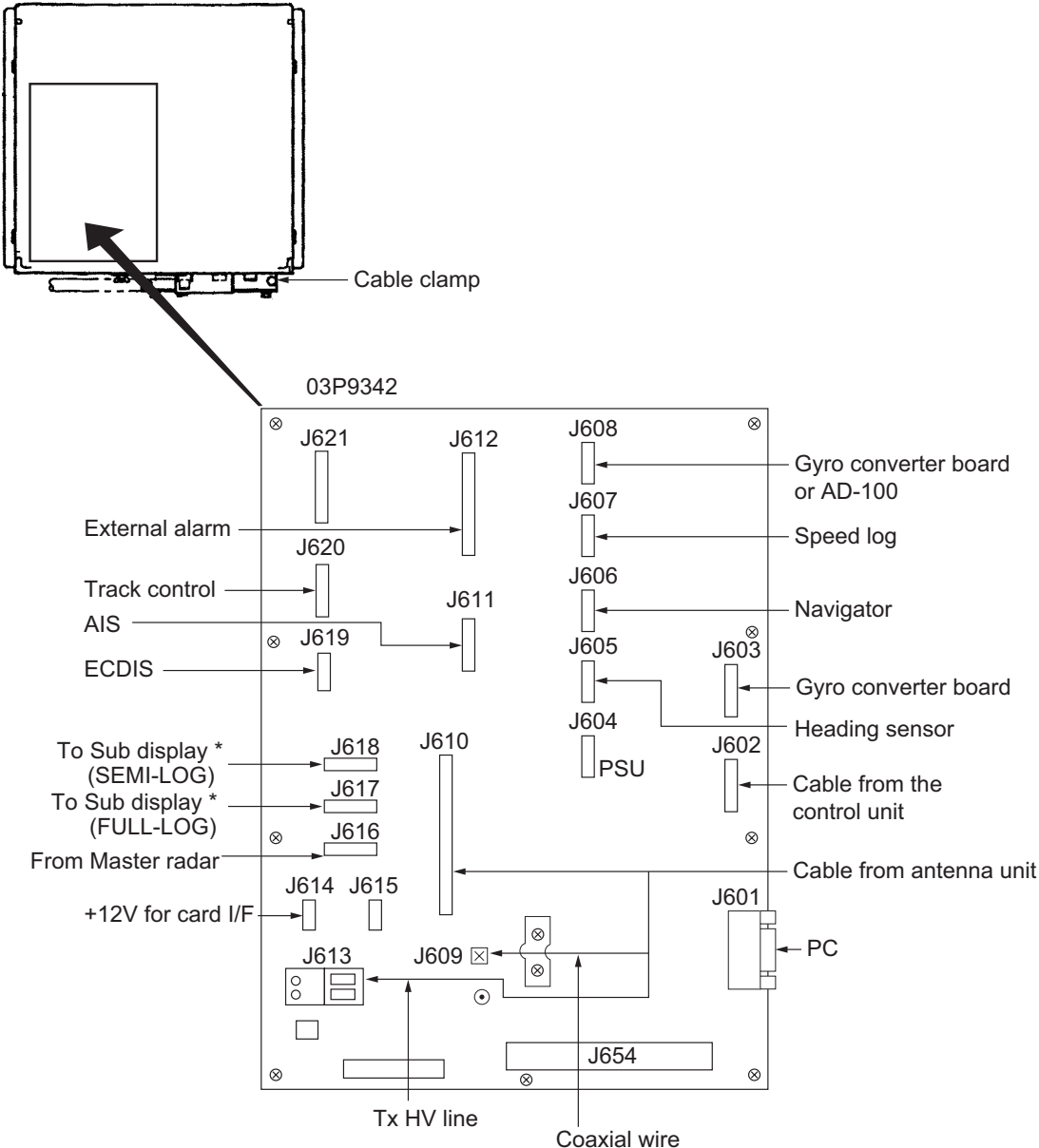
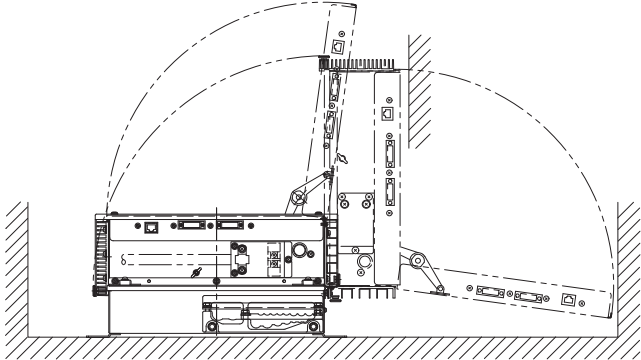

03P9342

\*: See page 2-11 for details.

### Cable fabrication for the cables connected to the 03P9342 board

- Signal cable RW-9600 (Between antenna unit and processor unit)

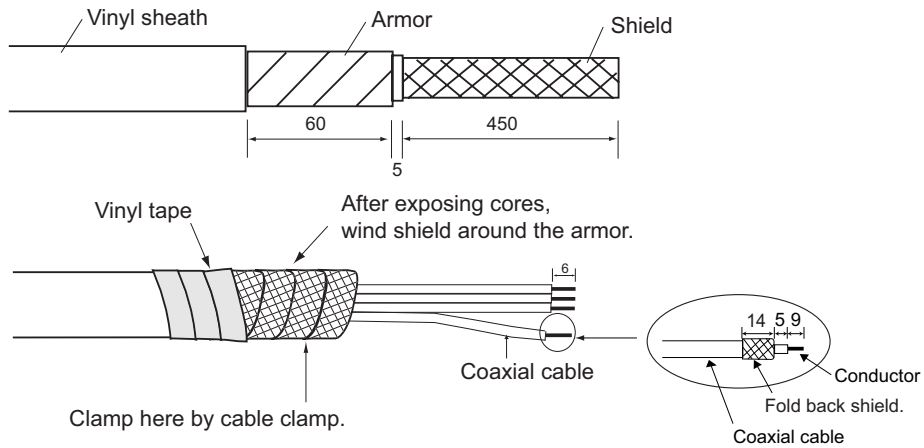

- Other cables for optional units

Use TTYCS-1 or TTYCS-4 (Japan standard cable) or equivalent.

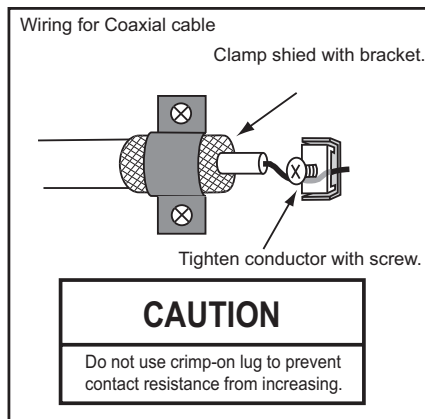
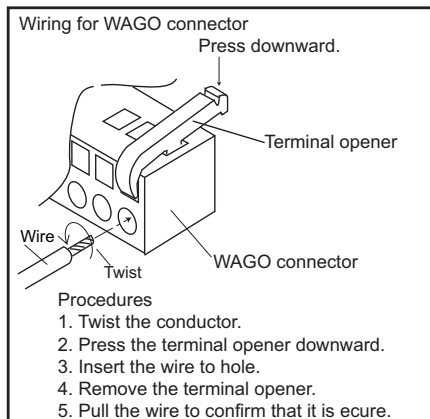
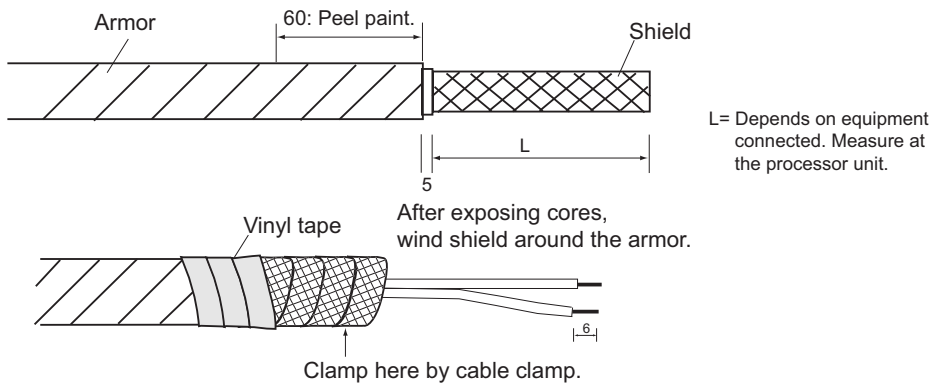
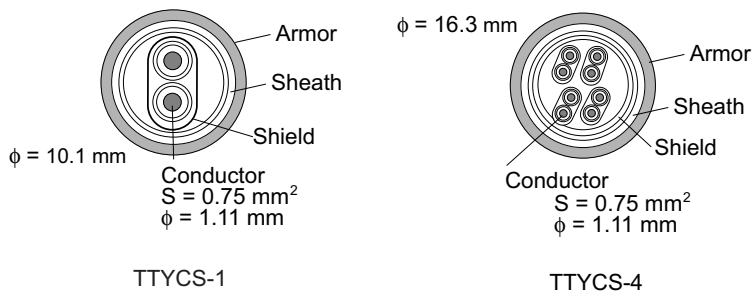

## Connection of Sub-display

A conventional remote display and/or FAR-2107 series radar can be connected to J617 and J618 in the processor unit as a sub-display. However, the control for GAIN and STC are different depending on J617 and J618. Refer to the table to connect sub-displays.

Port		Conventional remote display	FAR-2107 series radar
J617 (FULL-LOG)	Overall gain	Even if input video level is adjusted to 4 Vp-p, the gain is 8 db lower than that on the master radar.	The gain is 8 dB lower than that on the master radar.
	GAIN control	The GAIN control is effective.	The GAIN control has no effect.
	STC control	The STC control is effective.	The STC control has no effect.
J618 (SEMI-LOG)	Overall gain	When input video level is adjusted to 4 Vp-p, the gain becomes the same as that on the master radar.	The gain is almost same as that on the master radar.
	GAIN control	The GAIN control is effective.	The GAIN control has no effect.
	STC control	The STC control is effective, however this control is added on the signal adjusted by the master radar. So this port is not recommended to use.	The STC control has no effect.

## 2.5 Changing AC Power Specification of Processor Unit

To change AC power specification between 100 VAC and 220 VAC, add or remove jumper connector P108 on the PWR board 03P9339 and change the fuse on the processor unit according to ship's mains as shown in the table below. The figures below and on the next page show the location of the fuse and the jumper connector on the PWR board. Also, adjustment of the overvoltage detection circuit is required.

**Note:** To change from 200 VAC to 100 VAC, locally prepare the jumper connector, referring to the figure shown on the next page (VH8P connector housing is fitted at J108).

Power supply	Fuse	Jumper connector
100 VAC	10A	Added
220 VAC	5A	Removed

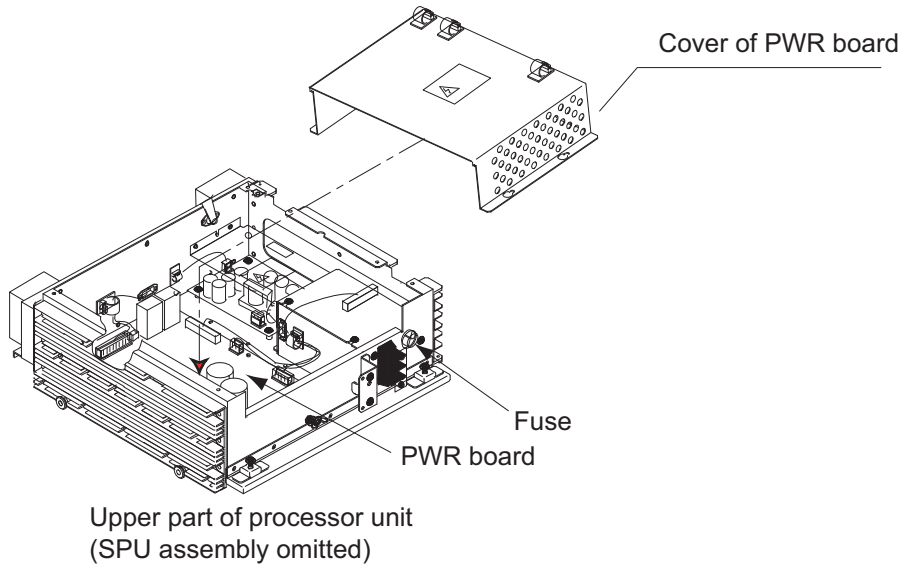

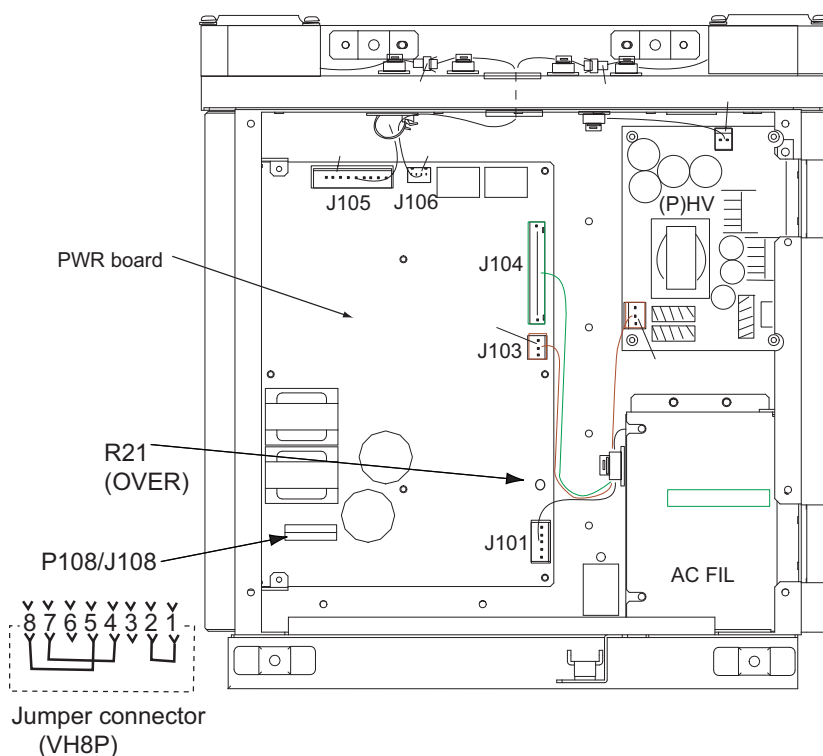

### How to adjust the overvoltage detection circuit:

1. Add or remove the jumper connector P108 and change the fuse.
2. Rotate R21 fully clockwise on the PWR board.
3. Connect a variable transformer between ship's mains and the input power terminal board TB-1 of the processor unit.
4. Adjust the variable transformer output (i.e., input voltage to the processor unit) as follows.  
For 100 VAC set: 144 VAC  
For 220 VAC set: 288 VAC
5. Turn on the radar and rotate the R21 counterclockwise gradually until the overvoltage detection circuit functions (i.e., power supply cuts off).
6. Lower the output voltage of the variable transformer and confirm that the radar automatically turn on with a voltage lower than 142VAC or 284VAC.
7. Gradually increase the output voltage of the variable transformer and confirm that the overvoltage detection circuit functions at 144V or 288VAC of the variable transformer output.
8. Assemble and connect the processor unit.

This page is intentionally left blank.

# 3. SETTING AND ADJUSTMENT

## 3.1 DIP Switch Setting

The processor unit is shipped for model FAR-2117/-D or FAR-2127/-D. If your model is FAR-2817 (-D)/2827 (-D)/2117-BB/2127-BB, change the DIP switch setting as follows.

1. Remove the top cover of the processor unit.
2. Open the SPU assembly block.

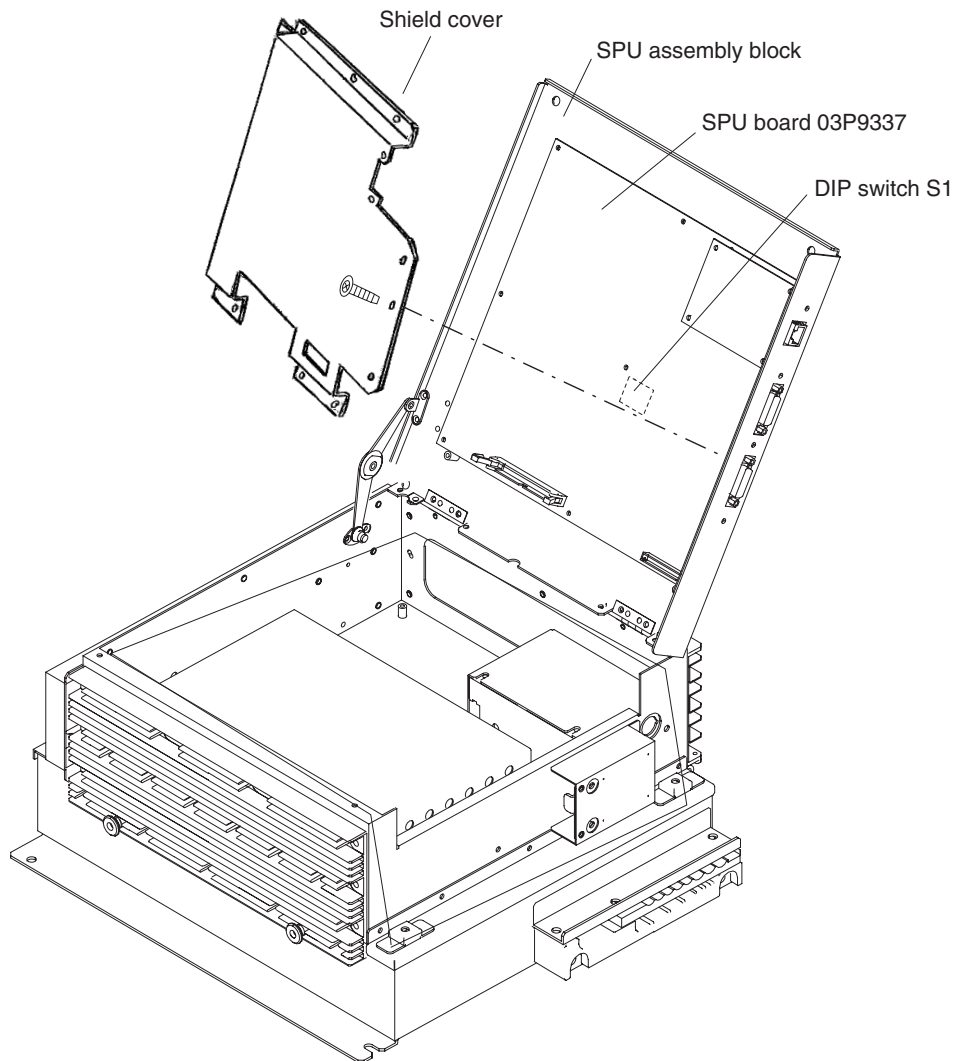

3. Set the DIP switch S1 as follows.

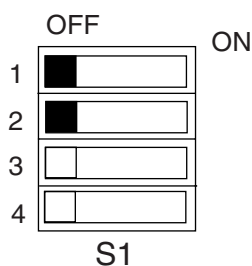

S1	Monitor SXGA for FAR-2117/-D, 2127/-D (Default)	Monitor UXGA for FAR2817/-D, 2827/-D (MU-231CR S. No. 0269 and later)	FAR-2117-BB FAR-2127-BB
1	OFF	ON	OFF
2	OFF	OFF	ON
3	Not used.		
4	Not used.		

**Note:** Set #1 and #2 of S1 to OFF for MU-231CR S. No. 0268 and earlier.

## 3.2 Initializing Tuning

1. Transmit the radar on 48 nm range and rotate the GAIN knob to show 70-80 of the gain bar.
2. Roll the trackball to choose the MENU box at the right side of the screen and then push the left button.
3. Roll the wheel to choose 1 ECHO and then push the wheel.

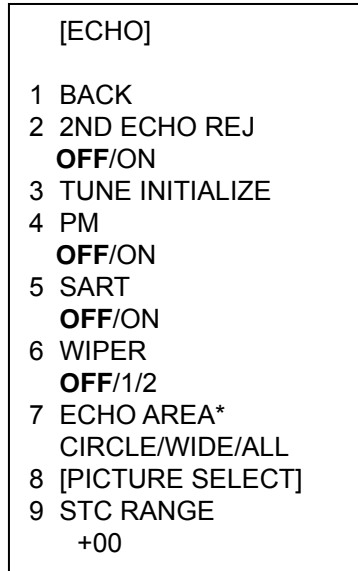

**Bold: Default settings**  
(Same for all menu illustrations)

\*: non IMO-type only

*ECHO menu*

4. Roll the wheel to choose 3 TUNE INITIALIZE.
5. Push the wheel to initialize automatic tuning.  
After a while, echoes appear on the screen. The message "TUNE INITIALIZE" appears in red during automatic tuning. When this message disappears, the tuning is completed. If necessary adjust the GAIN to show echoes clearly.
6. Push the right button twice to close the menu.



### 3.3 Heading Alignment

You have mounted the antenna unit facing straight ahead in the direction of the bow. Therefore, a small but conspicuous target dead ahead visually should appear on the heading line (zero degrees).

In practice, you will probably observe some small bearing error on the display because of the difficulty in achieving accurate initial positioning of the antenna unit. The following adjustment will compensate for this error.

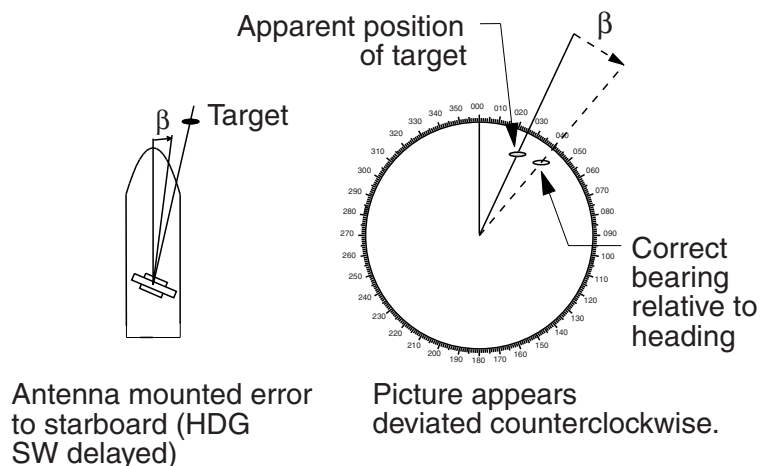
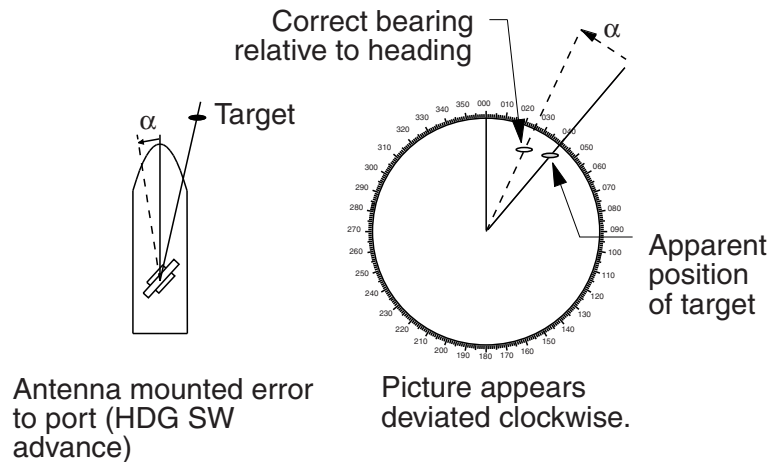

#### *Heading alignment*

1. Select a stationary target echo at a range between 0.125 and 0.25 nm, preferably near the heading line.
2. Operate the EBL control to bisect the target echo.

### 3. SETTING AND ADJUSTMENT

3. Read the target bearing.
4. Measure the bearing of the stationary target on the navigation chart and calculate the difference between actual bearing and apparent bearing on the radar screen.
5. Press the [MENU] key to show the main menu.
6. While pressing and holding down the [HL OFF] key, press the [MENU] key five times.
7. Press the [0] key to show the [INITIALIZE] menu.

```
[INITIALIZE]
1 BACK
2 [ECHO ADJ]
3 [SCANNER]
4 [INSTALLATION]
5 [OWN SHIP INFO]
6 [TT PRESET]
7 [NETWORK]
8 [OTHER]
9 [FACTORY]
```

**Note:** See next page to access the INITIALIZE menu with the trackball style control unit RCU-015.

8. Press the [2] key to open the [ECHO ADJ] menu.

```
[ECHO ADJ]
1 BACK
2 CABLE ATT ADJ
  AUTO/MANUAL
  30
3 HD ALIGN
  000.0°
4 TIMING ADJ
  0
5 MBS
  0
6 DEFAULT ANT HEIGHT
  5/7.5/10/15/20/
  25/30/35/40/45/
  more 50 m
7 NEAR STC CURVE
  2/2.5/3/3.5/4.2
8 MID STC CURVE
  3/4/5/6
9 FAR STC CURVE
  6/7/8
0 RING SUPPRESSION
  0
```

*ECHO ADJ menu*

9. Press the [3] key to choose the HD ALIGN option.
10. Key in the bearing difference. The setting range is 0 to 359.9°.
11. Confirm that the target echo is displayed at correct bearing on the screen.
12. Press the [MENU] key to finish.

## How to Access the Installation Mode with the RCU-015 Trackball Style Controller



1. By using the trackball, move the pointer until it highlights the MENU box as shown. **DO NOT CLICK** the menu box, just leave the arrow over the menu.

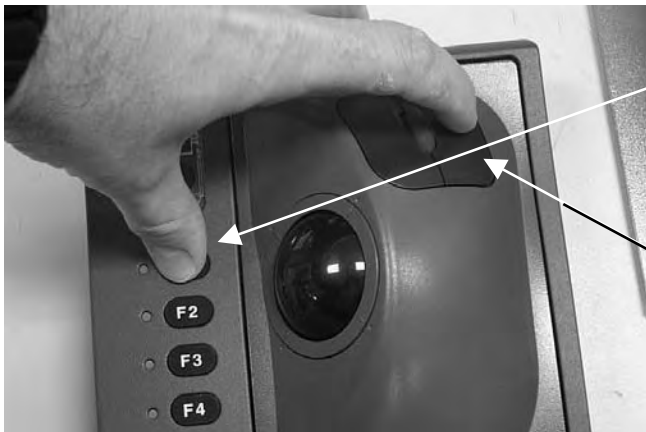

2. Press and hold down the F1 key. Keep it held down during the next step.

3. **Then**, click on the right controller button 5 times. You should hear a “triple Beep” on the fifth press.



The INITIALIZE menu will appear. Click on INSTALLATION to access the installation menus.

### 3.4 Adjustment Sweep Timing

Sweep timing differs with respect to the length of the signal cable between the antenna unit and the processor unit. Adjust sweep timing at installation to prevent the following symptoms:

- The echo of a “straight” target (for example, pier), on the 0.25 m range, will appear on the display as being pulled inward or pushed outward. See Figure below.
- The range of target echoes will also be incorrectly shown.

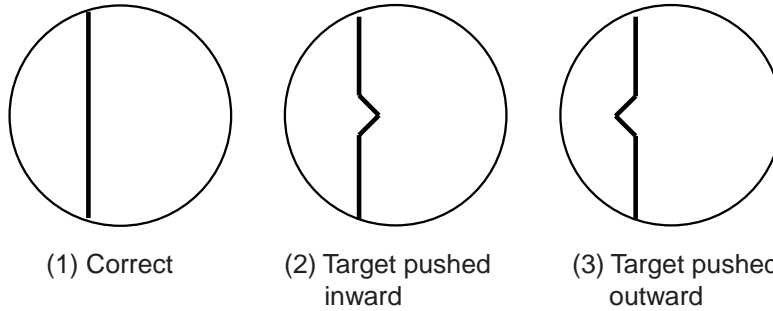

*Examples of correct and incorrect sweep timings*

1. Transmit on the 0.25 nm range.
2. Adjust radar picture controls to display picture properly.
3. Select a target echo which should be displayed straightly.
4. Press the [4] key to choose the [TIMING ADJ] on the [ECHO ADJ] menu.

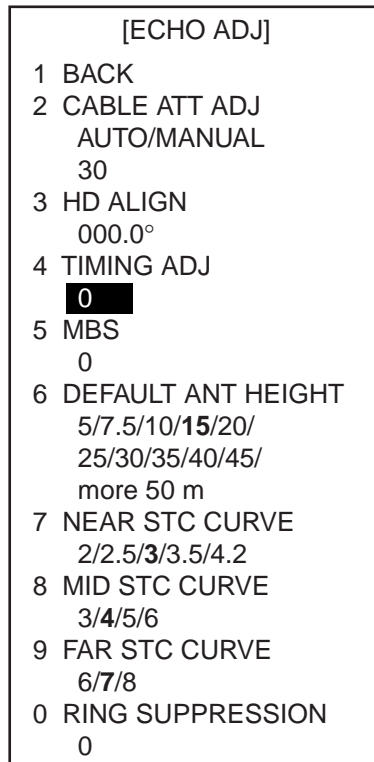

5. Rotate the wheel to set a suitable value which causes the target to be displayed straightly. The setting range is 0 to 4095.
6. Press the [MENU] key to finish.

## 3.5 Suppressing Main Bang

If main bang appears at the screen center, suppress it as follows.

1. Transmit the radar on a long range and then wait ten minutes.
2. Adjust gain to show a slight amount of noise on the display.
3. Select the 0.25 nm range. Adjust sea clutter control to suppress sea clutter.
4. Press [5] key to choose the MBS on the [ECHO ADJ] menu.

[ECHO ADJ]

- 1 BACK
- 2 CABLE ATT ADJ  
  AUTO/MANUAL  
  30
- 3 HD ALIGN  
  000.0°
- 4 TIMING ADJ  
  0
- 5 MBS  
  **0**
- 6 DEFAULT ANT HEIGHT  
  5/7.5/10/15/20/  
  25/30/35/40/45/  
  more 50 m
- 7 NEAR STC CURVE  
  2/2.5/3/3.5/4.2
- 8 MID STC CURVE  
  3/4/5/6
- 9 FAR STC CURVE  
  6/7/8
- 0 RING SUPPSSION  
  0

5. Rotate the wheel to set a suitable value so that the main bang disappears.  
  The setting range is 0 to 255.
6. Press the [MENU] key to finish.

## 3.6 Other Settings

### ECHO menu setting

Open the ECHO ADJ menu as described on page 3-3 and 3-4.

[ECHO ADJ]	
1	BACK
2	CABLE ATT ADJ AUTO/MANUAL 30
3	HD ALIGN 000.0°
4	TIMING ADJ 0
5	MBS 0
6	DEFAULT ANT HEIGHT 5/7.5/10/15/20/ 25/30/35/40/45/ more 50 m
7	NEAR STC CURVE 2/2.5/3/3.5/4.2
8	MID STC CURVE 3/4/5/6
9	FAR STC CURVE 6/7/8
0	RING SUPPRESSION 0

To close the menu, press the [MENU] key.

#### **CABLE ATT ADJ**

Before adjusting, set the radar as follows:

IR: 2, ES: off, EAV: off, 24nm range, long pulse

(Same as default setting of PICTURE1)

To adjust the cable attenuation manually, choose MANUAL by pressing [2] and the [ENTER] key, and then rotate the wheel so that noise just appears on the screen when the gain is set to 80. Default setting is 30 for the antenna cable length of 15m. The setting range is 0 to 73. To adjust automatically, choose AUTO and press the [ENTER] key. The message "CABLE ATT ADJ" appears in red at the bottom of the screen. It takes about five minutes to complete the adjustment, after which the radar goes into stand-by.

#### **DEFAULT ANT HEIGHT**

Select height (m) of the radar antenna unit from the sea surface among 5, 7.5, 10, 15, 20, 25, 30, 35, 40, 45 and "more 50 m".

#### **NEAR STC CURVE, MID STC CURVE AND FAR STC CURVE**

Use the default setting. Change the setting if desired according to sea condition.

#### **RING SUPPRESSION**

This is mainly used to remove "ring" noise which appears in the waveguide-type radar. Adjust so the rings disappear at the range of 0.125 nm. The setting range is 0 to 255.

## Scanner setting

1. Open the INITIALIZE menu described on page 3-2.
2. Press [3] key to open the SCANNER menu.

[SCANNER]	
1	BACK
2	BLIND SECTOR 1 START 000° ANGLE 000°
3	BLIND SECTOR 2 START 000° ANGLE 000°
4	ANT REVOLUTION LO/HI/AUTO
5	ANT SW OFF/ON/EXT
6	ANT STOPPED STBY/TX
7	M SPEC OFF/ON
8	BB TYPE NORMAL/BB
9	[DUAL RADAR]*

**Note 1:** Set the blind sector as minimum as possible.

**Note 2:** Do not set the blind sector in the bow direction.

\*non IMO-type only

To close the menu, press the [MENU] key.

### **BLIND SECTOR 1 and BLIND SECTOR 2**

Set area (up to 2) where no radar pulses will be transmitted, and heading should be adjusted before setting any blind sector. For example, set the area where an interfering object at the rear of the scanner would produce a dead sector (area where no echoes appear) on the display. To enter an area, enter start bearing relative the heading and dead sector angle. To erase the area, enter 0 for both the START and ANGLE sections. The setting range of START is 0 to 359° and ANGLE is 0 to 180°.

### **ANT REVOLUTION**

This menu item is used for 42 rpm antenna unit. The default is AUTO, where antenna revolution speed is high for short range setting and low speed for long range setting. When LO is selected, the antenna always rotate in 36 rpm, and HI, 42 rpm.

### **ANT SW and ANT STOPPED**

This is used for antenna maintenance by serviceman.

**Note:** Choose OFF at ANT SW to prevent the antenna rotation. As for ANT STOPPED, choose STBY to prevent transmission while the antenna is stopped.

### **M SPEC and BB TYPE**

Not used.

### **DUAL RADAR**

See section 3.7.

### 3. SETTING AND ADJUSTMENT

## INSTALLATION menu setting

Open the INSTALLATION menu by pressing [4] key on the INITIALIZE menu.

[INSTALLATION]	
1 BACK	
2 RADAR*	*: Cannot be selected.
<b>MAIN/SUB</b>	
3 RANGE UNIT **	**: non IMO-type only.
<b>NM/SM/km/kyd</b>	
4 RADAR NO***	***: No.1-4: with antenna unit No.5-8: without antenna unit
1/2/3/4/5/6/7/8	
5 RADAR POSN	
FORE/ <b>MAIN TOP</b> /	
MAIN 2ND/MAIN 3RD/	
AFT/PORT/	
STAR BOARD	
6 MODEL	
6/ <b>12</b> /25 UP/25 DOWN/	
50/30 UP/30 DOWN/60	
7 TYPE	
<b>IMO/A/B/C/W</b>	
8 ON TIME	
XXXXXXXX.X H	
9 TX TIME	
XXXXXXXX.X H	
0 PM GAIN ADJ	
0	

### RADAR

Choose main radar or sub radar.

### RANGE UNIT

Choose NM, SM, km or kyd (kilo yard) as appropriate, however-IMO type radar is "NM" only.

### RADAR NO and RADAR POSN

For multiple radar system using the network hub, set number (name) and antenna position for each system to easily distinguish the radar configuration.

### MODEL

Confirm the model of your radar. If the setting of this item is different from your model (combination of the antenna unit), the radar functions abnormally.

12: for FAR-2117/FAR-2817/ FAR-2117-BB

25UP: for FAR-2127/FAR-2827/ FAR-2127-BB

### TYPE

Choose type of radar: IMO, A, B, C, or W.



**TYPE**

Choose type of radar: IMO, A, B, C, or W.

**ON TIME and TX TIME**

These items show number of hours the radar has been turned on and transmitted, respectively. Value can be changed; for example, after replacing magnetron TX Time can be reset to 0.

**PM GAIN ADJ**

Note: If you install the Performance Monitor PM-31 at field, see section 4.4 on page 4-16.

When you choose this item, the radar setting changes as follows.

RANGE:	24 NM
PULSE:	LONG
BLIND SECTOR:	OFF
STC:	OFF by Manual
RAIN:	OFF by Manual
ECHO AVERAGE:	OFF
VIDEO CONTRAST:	2-B
TUNE:	AUTO

1. Adjust the GAIN control so that a slight amount of white noise appears on the screen.  
Arcs for performance monitor appear on the screen (Fig.1).
2. Adjust PM GAIN ADJ so that outer arc just disappears (Fig.2). The setting range is 0 to 255.

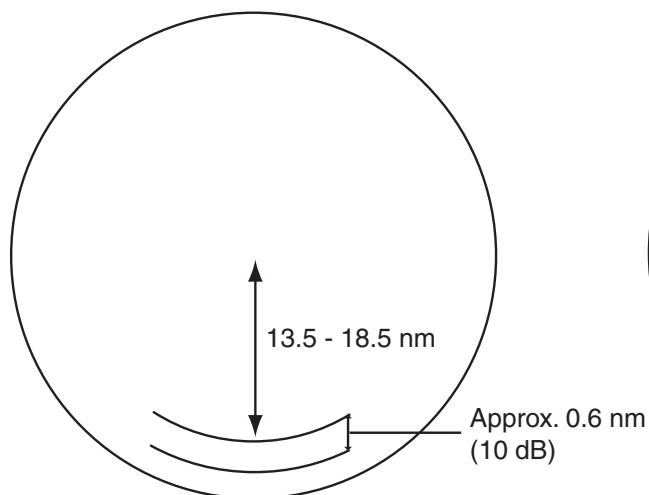

*Fig.1*

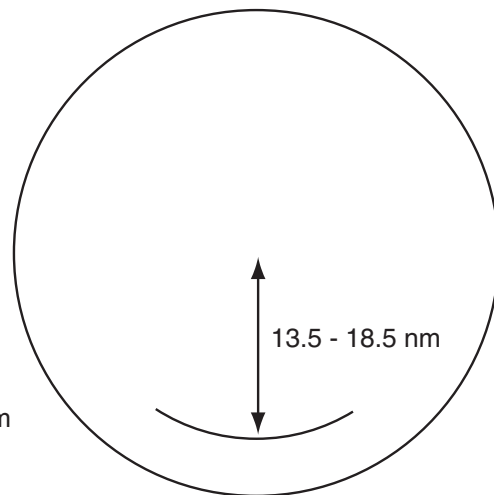

*Fig.2*

### 3. SETTING AND ADJUSTMENT

#### **OWN SHIP INFO menu setting**

Open the OWN SHIP INFO menu by pressing the [5] key on the INITIALIZE menu.

[OWN SHIP INFO]	
1	BACK
2	LENGTH/WIDTH
	LENGTH 100 m
	WIDTH 50 m
3	SCANNER POSN
	BOW 0 m
	PORT 0 m
4	GPS1 ANT POSN
	BOW 0 m
	PORT 0 m
5	GPS2 ANT POSN
	BOW 0 m
	PORT 0 m
6	CONNING POSN
	BOW 0 m
	PORT 0 m

#### **LENGTH/WIDTH and SCANNER POSN**

To inscribe own ship shape on the screen when you choose it on the menu, enter length and width of the ship and antenna position from the bow and left sides.

The setting ranges are as follows.

LENGTH: 0 to 999 m

WIDTH: 0 to 999 m

BOW: 0 to 999 m

PORT: 0 to 999 m

#### **GPS 1 ANT POSN and GPS 2 ANT POSN**

These items are needed for AIS information. Enter the GPS antenna position from the bow and left sides. The setting ranges are the same as above.

#### **CONNING POSN**

Enter the conning position in the wheelhouse, from the bow and left sides. The setting ranges are the same as above.

When you set the display reference point to the conning position, these values are used to correct the radar antenna position.

**Note:** If two or more radars are installed, items other than 3 SCANNER should be the same on each radar.

## TT PRESET menu setting

Open the TT PRESET menu by pressing [6] key on the INITIALIZE menu.

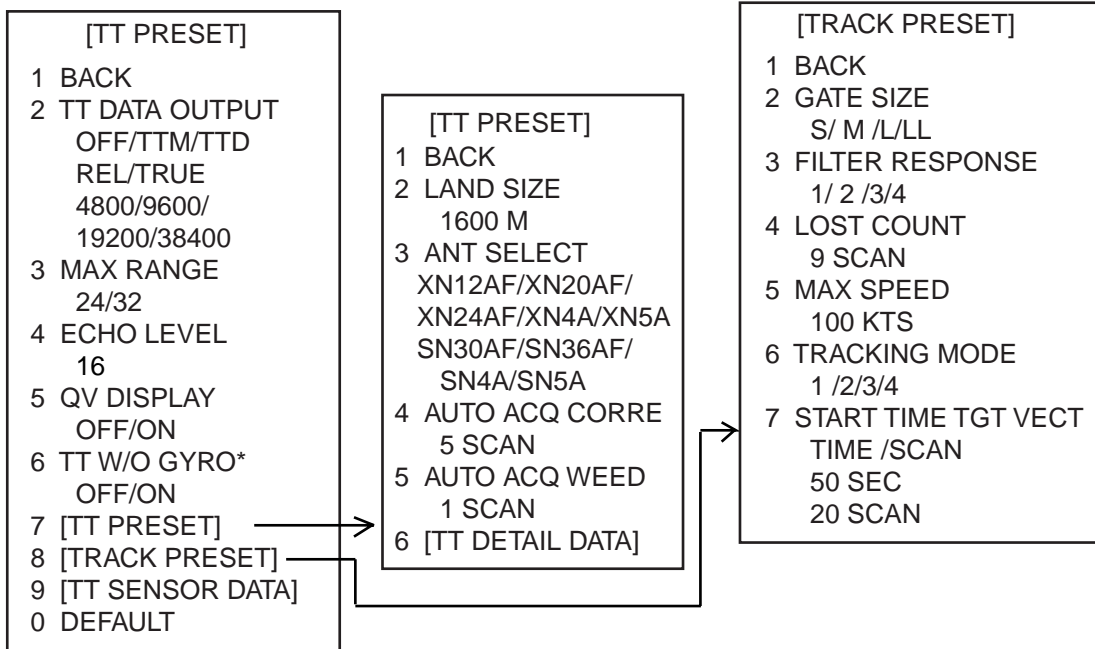

\*: Not on IMO radar

### TT DATA OUTPUT

Set the output format from J619 (sentence, bearing and baud rate) of tracked targets.

Sentence: (OFF: No output, TTM: Tracked target information, TTD: Tracked target data)

Bearing: REL: Target bearing from own ship, degree relative,  
target course, degree relative.

TRUE: Target bearing, degree true, target course, degree true.

Baud rate: (4800, 9600, 19200 or 38400 bps)

**NOTE:** The TT DATA OUTPUT port changes according to the setting for INS as described on page 3-15.

INS-OFF: Output from J619 port only

INS-SERIAL: Output from J619 and J620 (TTM only) ports

INS-LAN: Output from J619 and NETWORK (TTM only) ports

### MAX RANGE

Choose the target tracking range, 24 or 32 nm.

### ECHO LEVEL

Set the detection level of echoes. The setting range is 1 to 31.

### QV DISPLAY

OFF: Normal picture

ON: Quantized picture; always off at power on

### 3. SETTING AND ADJUSTMENT

#### **TT W/O GYRO (Not on IMO radar)**

If a gyrocompass is not connected, choose the TT function, ON(working) or OFF (no working).

#### **LAND SIZE**

Set the land size in units of 100 m. The setting range is 100 to 3000 m.

#### **ANT SELECT**

Set the antenna radiator type of your radar.

#### **AUTO ACQ CORRE**

Set the correlation count of automatic acquisition. The setting range is 3 to 10.

#### **AUTO ACQ WEED**

Set the cancel count of automatic acquisition. The setting range is 1 to 5.

#### **GATE SIZE**

Set the gate size among S, M, L, or LL.

#### **FILTER RESPONSE**

Set the filter response function. The setting range is 1 to 4.

#### **LOST COUNT**

Set the lost count. The setting range is 1 to 20.

#### **MAX SPEED**

Set the maximum tracking speed. The setting range is 40 to 150.

#### **TRACKING MODE**

Set the tracking mode among 1 to 4.

#### **START TIME TGT VECT**

Choose time which a vector appears after acquisition, TIME or SCAN and set seconds or scan counts.

## OTHER menu setting

Open the OTHER menu by pressing [8] key on the INITIALIZE menu.

[OTHERS]	
1	BACK
2	DEMO ECHO OFF/EG/TT-TEST/PC
3	EAV W/O GYRO OFF/ON
4	TT CATEGORY SELECT CAT1/CAT2•3
5	INS OFF/SERIAL/LAN

### EAV w/o GYRO

If a gyrocompass is not connected, choose the echo average function, ON (working) or OFF (no working).

### TT CATEGORY SELECT

Choose CAT1 or CAT2•3 depending on your ship's size.

CAT1: All ships over than 10,000 GT

CAT2: All ships between 500 and 10,000 GT

CAT3: All ships less than 500 GT

### INS

Choose appropriate item according to the ECDIS connected.

OFF: No connection

SERIAL: When connecting FEA-2105 series ECDIS.

LAN: When connecting FEA-2107 series ECDIS.

### 3.7 Dual Radar Display (non IMO-type only)

The image from two or more radars may be shown together on one radar display. This allows you to take advantage of the best characteristics radars has to offer.

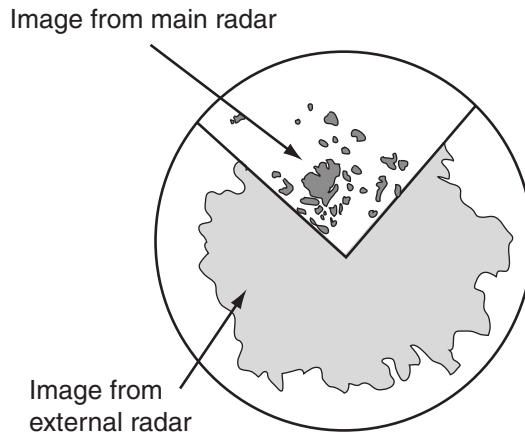

Separate internal and external images ("COMBINE" setting)

The following should be done in order to enable the dual radar display:

- Set antenna position correctly on both the main radar and the external radar.
- Select external radar to use, from the DUAL RADAR menu. (See paragraph 3.7.3.)

#### 3.7.1 Enabling/Disabling the Dual Radar Display

Enable or disable the dual radar display as shown in this section.

**Note 1:** The Tx blanking sector boundary lines are not shown when the dual radar display is active. Further, neither the internal or external image is shown in the Tx blanking sector.

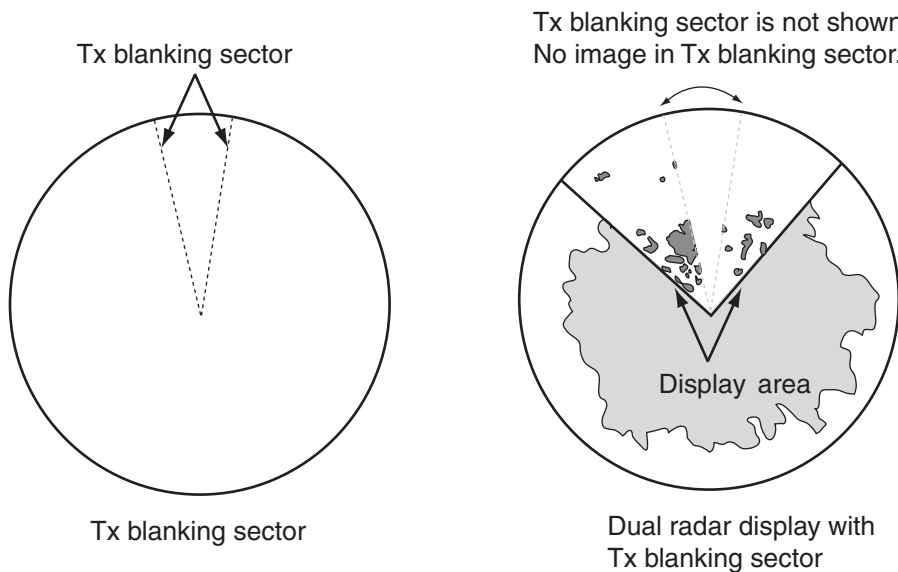

**Note 2:** In the dual radar display, a guard zone set on the main radar is also accommodated on the external radar. When the position of the antennas for the main and external radars is different and the No. 2 guard zone is set on a close-in range, the on-screen guard zone may be shifted slightly from both the main radar antenna reference and external radar antenna reference. Accordingly, on the dual radar display, the actual guard zone area may be shifted slightly. For example, the guard alarm sounds against a target which has almost entered the guard zone. The further the range the smaller the shift; however, there is little shift with the No.1 guard zone (3-6 mile range, fixed). Further, do not set a guard zone such that it straddles a boundary line of the dual radar sector.

A guard zone cannot be set while the dual radar display is active. Set a zone before activating the dual radar display.

1. Open the INITIALIZE menu. See page 3-4.
2. Press the [3] key to show the SCANNER menu.
3. Select 9 [DUAL RADAR] and push the left button.

[DUAL RADAR]

1 BACK

2 DUAL RADAR  
OFF/ COMBINE

3 COMBINE MODE  
OWN/EXT

4 COMBINE SECTOR  
START 000°  
ANGLE 000°

5 COMBINE RANGE  
START 00.00NM  
LENGTH 00.00NM

6 EXT RADAR  
1/2/3/4

4. Select 2 [DUAL RADAR] and push the left button.
5. Select OFF or COMBINE as appropriate and push the left button. For COMBINE, the ANTENNA box at the top left-hand side becomes gray.
  - OFF: Turn off the dual radar display.
  - COMBINE: Display a part of the external radar image in the window on the main radar.

### 3. SETTING AND ADJUSTMENT

Push the right button four times to close the menu.

**Note 1:** The dual radar function becomes inoperative when the external radar is turned off, set to stand-by, or set as sub display. When this happens, the buzzer sounds and the message "EXT RADAR STBY" (power off, stand-by only) appears.

**Note 2:** The dual radar display is inoperative on the stern-up and shuttle ferry modes.

**Note 3:** Some functions of the external radar image, listed below, may be adjusted from the main radar.

1) Left-click the radar selection indication "CTRL OWN" at the top-left side of the screen to switch control to the external radar. The indication then shows "CTRL EXT". Each click of the indication switches control between the main and external radar alternately.

2) The external image may be adjusted from the main radar. The following functions may be adjusted:

- Transmit/stand-by switching
- PICTURE box setting
- GAIN
- A/C SEA
- A/C RAIN
- Tuning
- ECHO menu setting (2nd trace echo rejector, performance monitor)
- Range scale
- TT functions.
- CPA/TCPA box settings



### 3.7.2 Specifying Sector Width and Length

When 2 DUAL RADAR in the DUAL RADAR menu is set for "COMBINE", specify the width and length of the sector from the external radar to display on own radar.

1. Open the INITIALIZE menu.
2. Press the [3] key to show the SCANNER menu.
3. Select 9 [DUAL RADAR] and push the left button.
4. Select 3 COMBINE MODE and push the left button.
5. Select OWN or EXT and push the left button.

**OWN:** Set own radar's antenna as reference point and set display area of own radar. The area outside that set here is where the image from the external radar will be displayed.

**EXT:** Set external radar's antenna as reference point and set display area of external radar. The area outside that set here is where the image from own radar will be displayed.

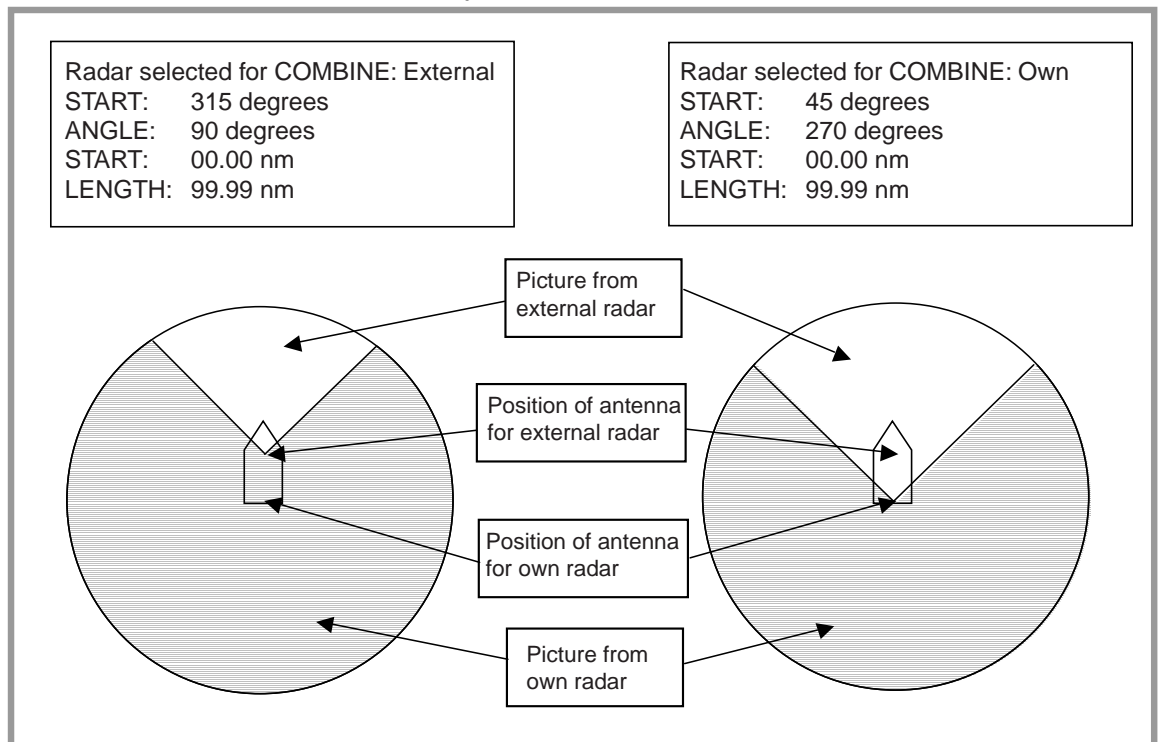

6. Select 4 COMBINE SECTOR and push the left button.

### 3. SETTING AND ADJUSTMENT

- Use the scrollwheel to set START and ANGLE, referring to the description and example below. Spin the scrollwheel to set and push it to confirm.

A solid green line marks the dual radar display area.

- START: Start point of the sector (in degrees, 000-359)
- ANGLE: Width of the sector (in degrees, 000-359)

In the example below, START is 130° and ANGLE is 100°.

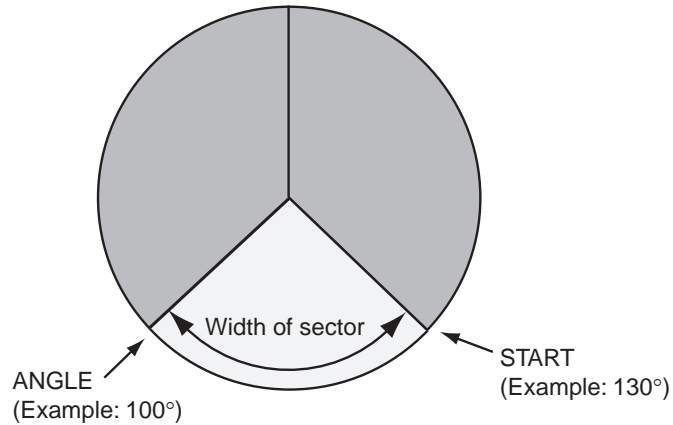

- Select 5 COMBINE RANGE and push the left button.
- Use the scrollwheel to set START and LENGTH, referring to the example below. Spin the scrollwheel to set and push it to confirm.
  - START: Set range start point.
  - LENGTH: Set length of sector.

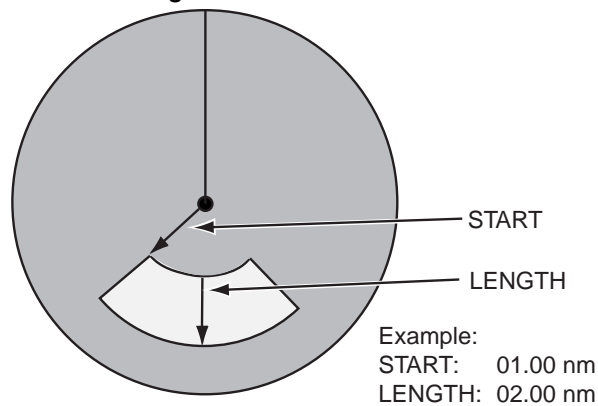

Push the right button four times to close the menu.

### 3.7.3 Choosing External Radar (image source)

Select the external radar to use in the dual radar display.

1. Open the INITIALIZE menu.
2. Press the [3] key to show the SCANNER menu.
3. Select 9 [DUAL RADAR] and push the left button.

[DUAL RADAR]
1 BACK
2 DUAL RADAR OFF/ COMBINE
3 COMBINE MODE OWN/EXT
4 COMBINE SECTOR START 000° ANGLE 000°
5 COMBINE RANGE START 00.00NM LENGTH 00.00NM
6 EXT RADAR 1/2/3/4

4. Select 6 EXT RADAR and push the left button.
5. Select desired radar no. and push the left button.  
Only the numbers of connected radars are valid. Radar no. is set on the Installation Setting menu.
6. Press the [MENU] key to close the menu.

### 3. SETTING AND ADJUSTMENT

This page is intentionally left blank.

# 4. INSTALLING OPTIONAL EQUIPMENT

---

## 4.1 Gyro Converter GC-10

The Gyro Converter GC-10, incorporated inside the processor unit, converts analog gyrocompass reading into digital coded bearing data for display on the radar screen.

This section explains how to install the GC-10 (mainly consisting of the GYRO CONVERTER board) and set it up according to gyrocompass connected.

### Installing the GYRO CONVERTER board

Necessary Parts: GC-10-2 (Code number 000-080-440)

See packing list for details at the back of this manual.

1. Open the processor unit.

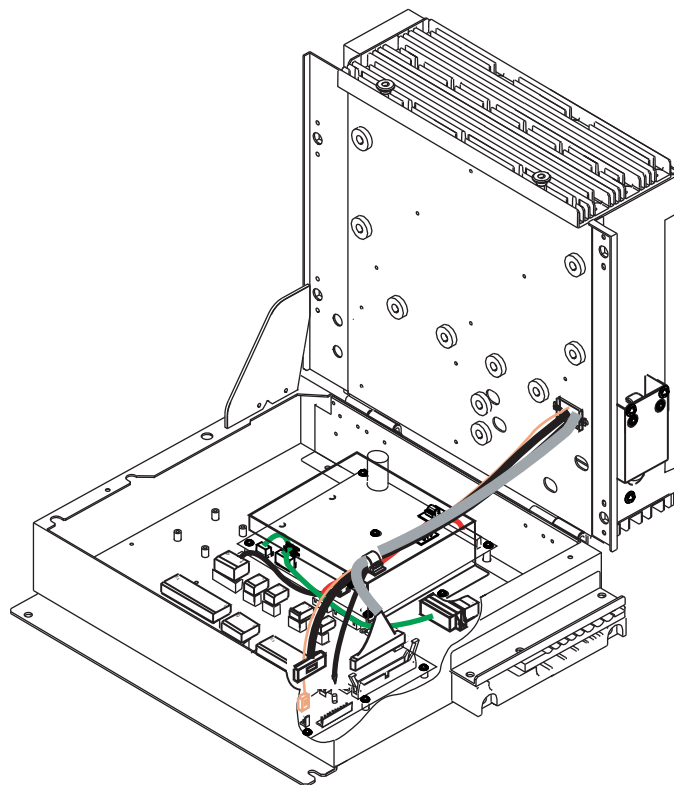

*Processor unit (Opened)*

#### 4. INSTALLING OPTIONAL EQUIPMENT

2. Fasten the GYRO CONVERTER board in the processor unit with five washer head screws and male connector 231-607/019-FUR (called J602) with two screws.

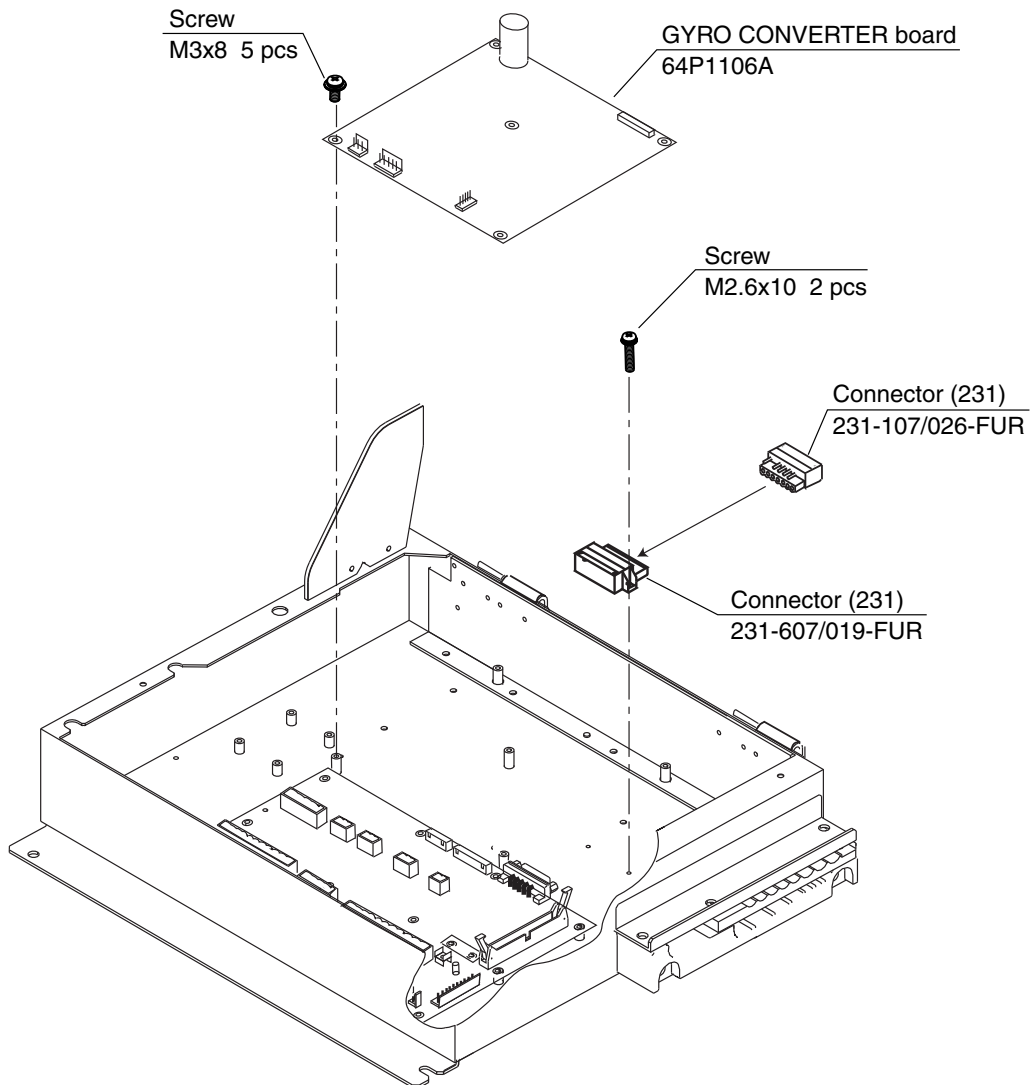

*Attaching GYRO CONVERTER board in the processor unit*

3. Connect the GYRO CONVERTER board and the 03P9342 board with connector assemblies 03-2088 and 03-2091.

4. Connect the GYRO CONVERTER board and J602 with two connector assemblies 03-2089 and 03-2090.

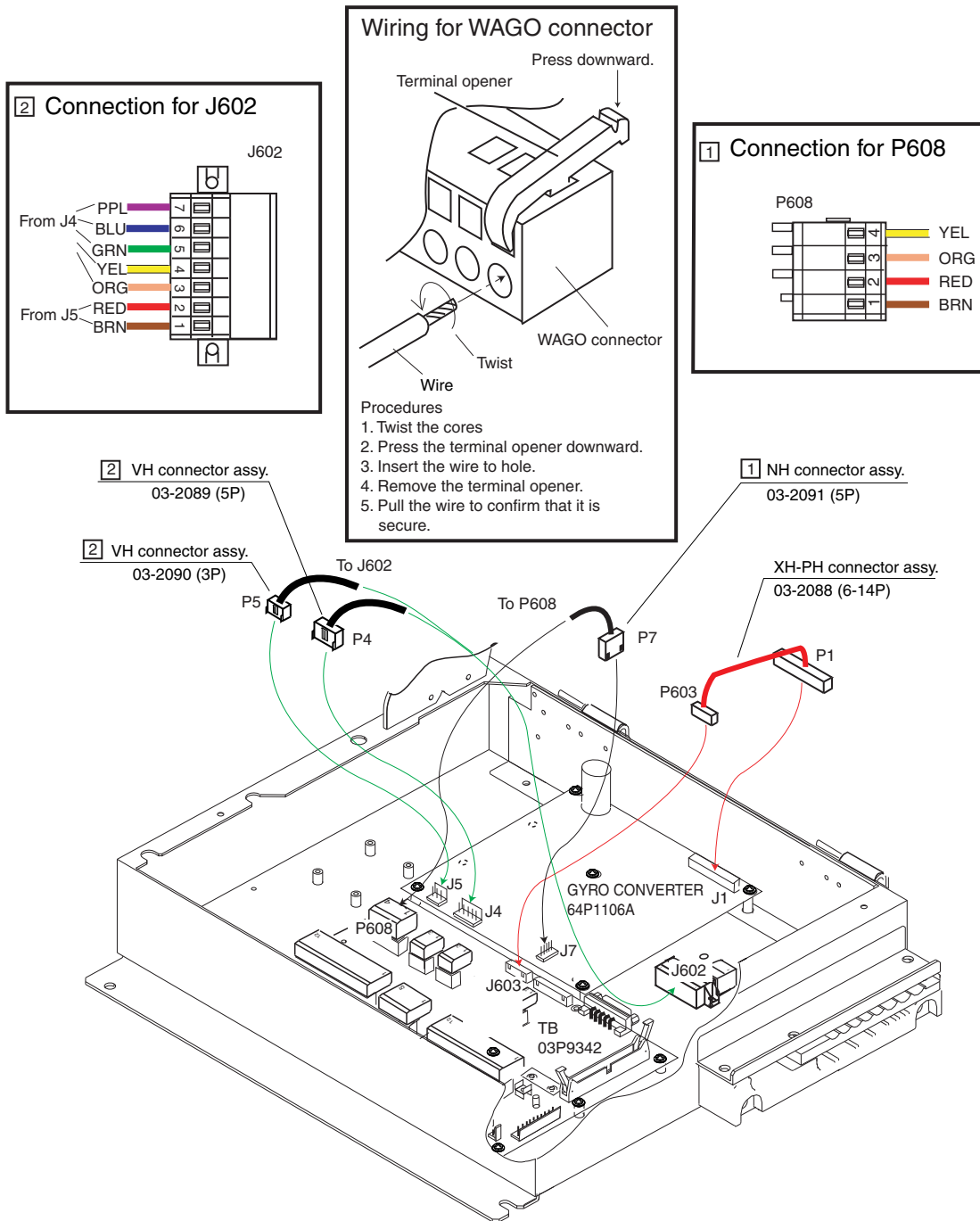

Connecting connector assemblies

#### 4. INSTALLING OPTIONAL EQUIPMENT

5. Confirm gyrocompass specifications and set up the DIP switches and jumper wires on the GYRO CONVERTER board according to gyrocompass connected:
  - Setting jumper wires and DIP switches by gyrocompass specifications: page 4-5
  - Setting jumper wires and DIP switches by make and model of gyrocompass: page 4-7
  - Location of jumper wires and DIP switches: page 4-8
6. Pass gyrocompass cable through the cable clamp and connect it to connector J602 as shown in the figure on page 4-3.
7. Attach the clamps on the plastic cover and then attach the cover to the GYRO CONVERTER board as shown in the figure below. Insert cables to the clamp ED-1, respectively.

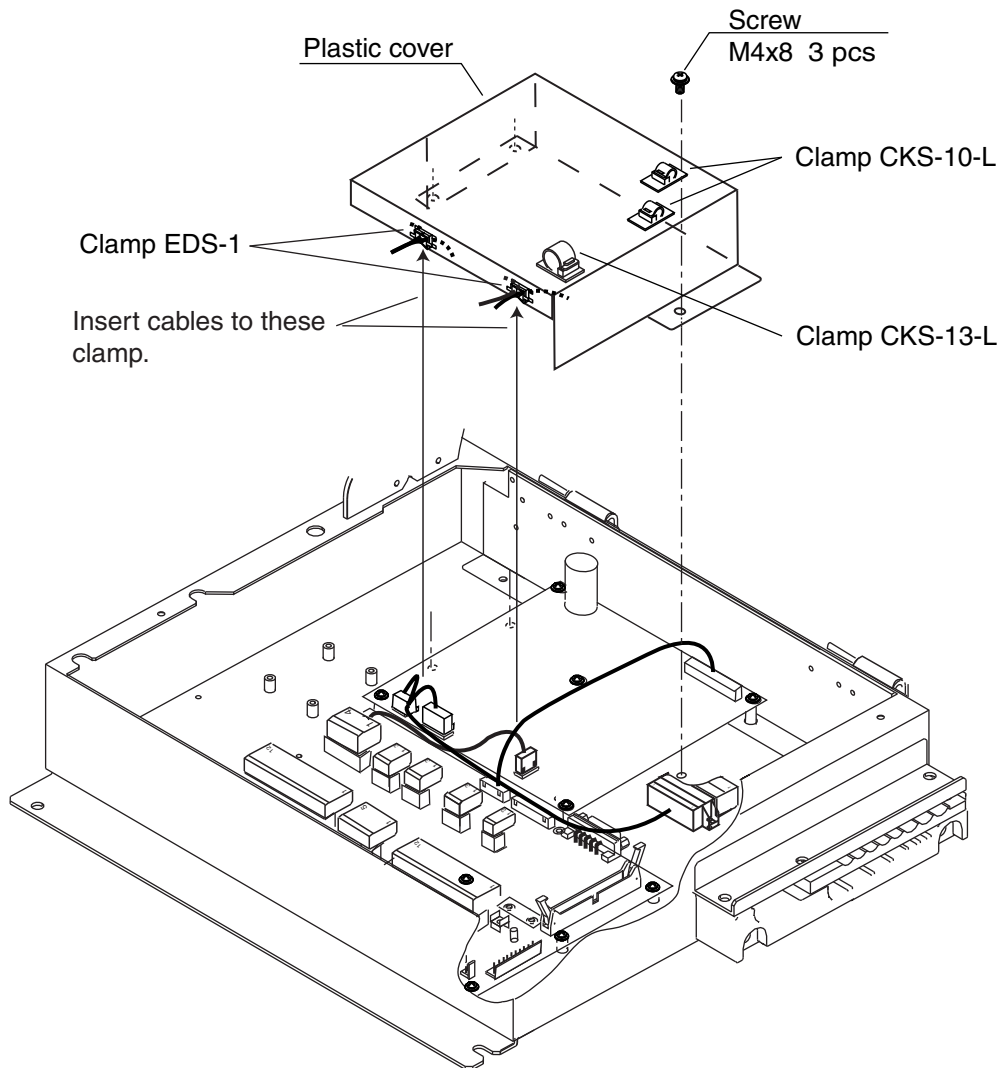

*Attaching plastic cover for GYRO CONVERTER board*

8. Close the processor unit.



## Connection of external power supply

An external power supply is necessary when the repeater signal is step-by-step type and the step voltage is below 20 V or output voltage is less than 5 W.

1. Cut jumper wire JP1 on the GYRO CONVERTER board when an external power supply is used.
2. Connect gyro cable and power cable as shown below.

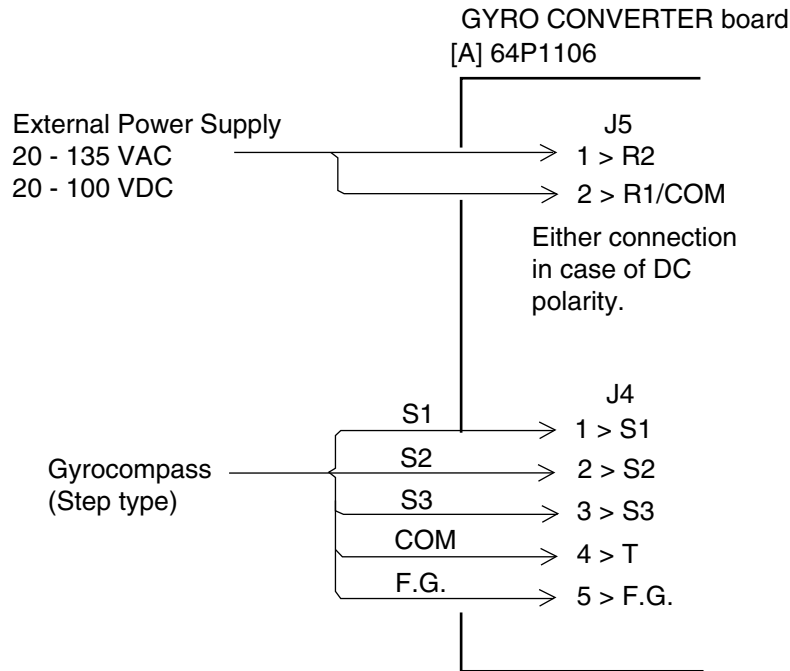

*Connection of external power supply to GYRO CONVERTER board*

## DIP switch, jumper wire settings

### Default setting

The gyro converter GC-10 is set at the factory for connection with the gyrocompass specifications below.

AC synchronous signal: 50/60 Hz  
 Rotor voltage: 60 V to 135 V AC  
 Stator voltage: 60 V to 135 V AC  
 Gear ratio: 360x  
 Supply voltage: 30 V to 135 V AC

If the specifications of the gyrocompass differ from those mentioned above, change jumper wire and DIP switch settings on the GYRO CONVERTER board. Settings may be changed according to gyrocompass specifications (see page 4-6) or make and model of gyrocompass (see page 4-7). For the location of DIP switches and jumper wires, see page 4-8.

Note: If you change the setting with power supplied, set #8 of SW2 from OFF to ON, then OFF again.

#### 4. INSTALLING OPTIONAL EQUIPMENT

### Setting method 1: DIP switch settings and gyrocompass specifications

#### 1) Gyrocompass type

Gyrocompass type	SW 1-4	SW 1-5	SW 1-6	JP1
AC synchronous	OFF	OFF	OFF	#1, #2, #3
DC synchronous	OFF	OFF	OFF	#2, #3, #4
DC step	ON	OFF	OFF	#4, #5, #6
Full-wave pulsating current	OFF	ON	OFF	#4, #5, #6
Half-wave pulsating current	ON	ON	OFF	#4, #5, #6

#### 2) Frequency

Frequency	SW 1-7	SW 1-8	Remarks
50/60 Hz	OFF	OFF	AC synchronous pulsating current
400 Hz	ON	OFF	AC synchronous pulsating current
500 Hz	OFF	ON	AC synchronous pulsating current
DC	ON	ON	DC synchronous DC step

#### 3) Rotor Voltage (between R1 & R2)

Rotor Voltage	SW 2-1	JP3
20 to 45 VAC	ON	#2
30 to 70 VAC	OFF	#2
40 to 90 VAC	ON	#1
60 to 135 VAC	OFF	#1

#### 4) Stator Voltage (between S1 & S2)

Stator Voltage	SW 2-2	SW 2-3	JP2
20 to 45 VAC, or 20 to 60 VDC	ON	OFF	#2
30 to 70 VAC, or 40 to 100 VDC	OFF	OFF	#2
40 to 90 VAC	ON	OFF	#1
60 to 135 VAC	OFF	OFF	#1

#### 5) Ratio

Ratio	SW 1-1	SW 1-2	SW 1-3
360X	OFF	OFF	OFF
180X	ON	OFF	OFF
90X	OFF	ON	OFF
36X	ON	ON	OFF

#### 6) Supply Voltage

Stator Voltage	JP4	JP5
20 to 45 VAC, or 20 to 60 VDC	#2	#2
30 to 70 VAC, or 40 to 100 VDC	#1	#1

#### 7) AD-10 format data

##### Tx interval

Select data transmitting interval for ports 1 to 6 with jumper wires JP6 and JP7: #25 for 25 ms, #200 for 200 ms.

**Note:** The Tx interval is available in 25 msec or 200 msec. Use 25 msec for radar.

#### 8) NMEA-0183

##### Tx interval and Output sentence

Tx interval	SW 2-5	SW 2-6	Output sentence
1 s	OFF	OFF	HDT+VHW
200 ms	ON	OFF	HDT
100 ms	OFF	ON	HDT
25 ms	ON	ON	HDT

#### 9) NMEA-0183 Version no.

Version no.	SW3-1
1.5	OFF
2.0	ON

#### 10) NMEA-0183 Baud rate

Baud rate	SW3-2
4860bps	OFF
38400bps	ON

#### 11) Power fail detection

Talker	SW3-3
Disable	OFF
Enable	ON

(Use OFF for radar.)

#### 12) Stator signal breaking detection

Detection	SW2-7
Execute	OFF
No execute	ON

SW2-4: factory use only  
SW3-4: not used

**Setting method 2: by make and model of gyrocompass**

Maker	Models	Specification	SW 1-1	SW 1-2	SW 1-3	SW 1-4	SW 1-5	SW 1-6	SW 1-7	SW 1-8	SW 2-1	SW 2-2	SW 2-3	JP1	JP2	JP3	JP4	JP5	
Anschutz	Standard 2,3	AC synchronous 50/60Hz Rotor voltage: 50/60V Stator voltage: 22V 360x	OFF	OFF	OFF	OFF	OFF	OFF	OFF	OFF	OFF	ON	OFF	#1, #2,#3	#2	#2	#1	#	
	Standard 4,6	AC synchronous 50/60Hz Rotor voltage: 50/60V Stator voltage: 90V 360x	OFF	OFF	OFF	OFF	OFF	OFF	OFF	OFF	OFF	OFF	OFF	#1, #2,#3	#2	#1	#1	#	
	Standard 20	DC step 35V 180x COM(-), 3-wire(+)	ON	OFF	OFF	ON	OFF	OFF	ON	ON	-	ON	OFF	#4, #5,#6	#2	-	#2	#	
Yokogawa Navtec (Plath type)	C-1/1 A/2/3 A-55, B-55	AC synchronous 50/60Hz Rotor voltage: 50/60V Stator voltage: 22V 360x	OFF	OFF	OFF	OFF	OFF	OFF	OFF	OFF	OFF	ON	OFF	#1, #2,#3	#2	#2	#1	#	
	CMZ-700	DC step 24V 180x COM(+), 3-wire(-)	ON	OFF	OFF	ON	OFF	OFF	ON	ON	-	ON	OFF	Remove	#2	-	*	*	
	CMZ-250X/ 300X/500	DC synchronous 360x	OFF	OFF	OFF	OFF	OFF	OFF	OFF	ON	ON	-	ON	OFF	Remove	#2	-	*	*
		DC step 35V 180x COM(+),3-wire(-)	ON	OFF	OFF	ON	OFF	OFF	ON	ON	ON	-	ON	OFF	#4, #5,#6	#2	-	#2	#2
	CMZ-100/200/ 300 C-1Jr,D-1Z/1/3 IPS-2/3	AC synchronous 50/60Hz Rotor voltage: 100V Stator voltage: 90V 360x	OFF	OFF	OFF	OFF	OFF	OFF	OFF	OFF	OFF	OFF	OFF	OFF	#1, #2,#3	#1	#1	#1	#1
CMZ-50 See note below.	step 35V 180x COM(+),3-wire(-)	ON	OFF	OFF	ON	OFF	OFF	ON	ON	-	ON	OFF	OFF	Remove	#2	-	*	*	
Plath	NAVIGAT IIIII	AC synchronous 50/60Hz Rotor voltage: 50/60V Stator voltage: 68V 360x	OFF	OFF	OFF	OFF	OFF	OFF	OFF	OFF	OFF	OFF	OFF	#1, #2,#3	#2	#2	#1	#1	
Tokimec (Sperry type)	ES-1/2/11 GLT-101/102/ 103/106K/107	AC synchronous 50/60Hz Rotor voltage: 100/110V Stator voltage: 90V 36x	ON	ON	OFF	OFF	OFF	OFF	OFF	OFF	OFF	OFF	OFF	#1, #2,#3	#1	#1	#1	#1	
	ES-11A/110 TG-200 PR222R/2000 PR237L/H GM 21	AC synchronous 50/60Hz Rotor voltage: 100/110V Stator voltage: 22V 90x	OFF	ON	OFF	OFF	OFF	OFF	OFF	OFF	OFF	OFF	OFF	OFF	#1, #2,#3	#1	#1	#1	#1
	MK-14 MOD-1/2/T NK-EN,NK-EI	DC step 70V 180x COM(-), 3-wire(+)	ON	OFF	OFF	ON	OFF	OFF	ON	ON	-	OFF	OFF	#4, #5,#6	#2	-	#1	#1	
	SR-130/140	DC step 70V 180x 5-wire, open collector	ON	OFF	OFF	ON	OFF	OFF	OFF	OFF	-	OFF	OFF	#4, #5,#6	#2	-	#1	#1	
	TG-100/5000 PR-357/130/ 140, ES-17 GLT-201/202 /203	DC step 70V 180x COM(+), 3-wire(-)	ON	OFF	OFF	ON	OFF	OFF	ON	ON	-	OFF	OFF	#4, #5,#6	#2	-	#1	#1	
	TG-6000	DC step 24V 180x	ON	OFF	OFF	ON	OFF	OFF	ON	ON	-	ON	OFF	#4, #5,#6	#2	-	#2	#2	
	GM-11	AC synchronous 50/60Hz Rotor voltage: 100V Stator voltage: 90V 90x	OFF	ON	OFF	OFF	OFF	OFF	OFF	OFF	OFF	OFF	OFF	OFF	#1, #2,#3	#1	#1	#1	#1
	SR-120,ES-16 MK-10/20/30	DC step 35V 180x	ON	OFF	OFF	ON	OFF	OFF	ON	ON	-	ON	OFF	#4, #5,#6	#2	-	#2	#2	
Kawasaki	GX-81	AC synchronous 50/60Hz Rotor voltage: 100/110V Stator voltage: 90V 90x	OFF	ON	OFF	OFF	OFF	OFF	OFF	OFF	OFF	OFF	OFF	#1, #2,#3	#1	#1	#1	#1	
Armabrown	MK-10,MKL-1 SERIES1351, MOD-4	DC step 50V 180x COM(+), 3-wire(-)	ON	OFF	OFF	ON	OFF	OFF	ON	ON	-	OFF	OFF	#4, #5,#6	#2	-	#1	#1	
Robertson	SKR-80	DC step 35V 180x COM(-), 3-wire(+)	ON	OFF	OFF	ON	OFF	OFF	ON	ON	-	ON	OFF	#4, #5,#6	#2	-	#2	#2	

\*: Set JP4 and JP5 according to the voltage of the external power supply.

**Note:** If CMZ-50 has 35VDC, set JP1 to #4, #5, #6.

## 4. INSTALLING OPTIONAL EQUIPMENT

### Location of DIP switches, jumper wires on the GYRO CONVERTER board

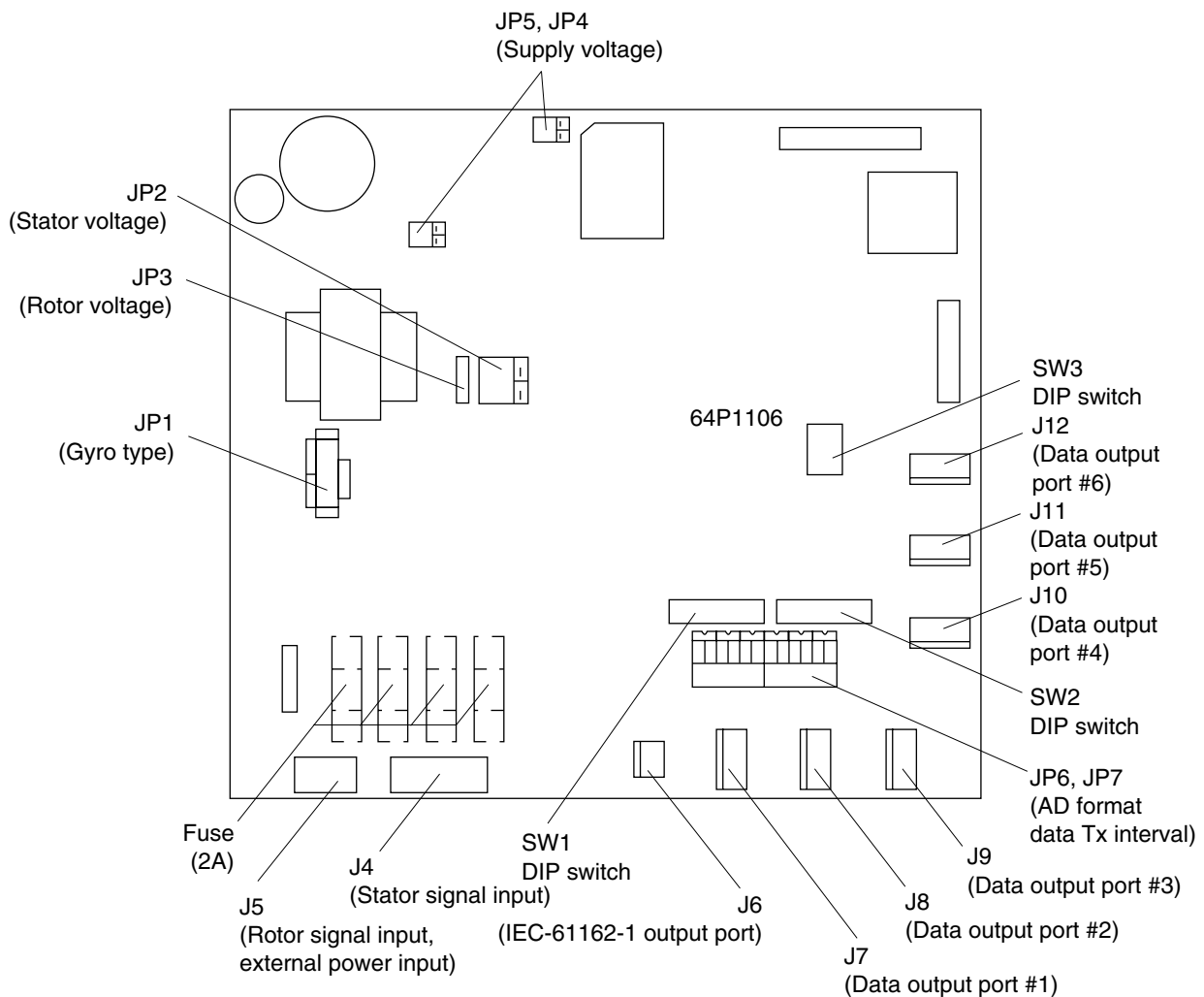

*GYRO CONVERTER board*

### **Setting the heading readout on the radar display**

Confirm that the gyrocompass is giving a reliable readout. Then, set the heading readout on the radar display with the gyrocompass readout as follows:

1. Roll the trackball to place the arrow in the HDG box at the top right corner of the screen.
2. Push the right button on the trackball module to open the HDG menu.

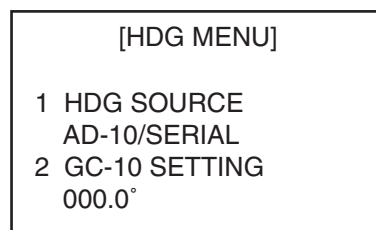

*HDG menu*

3. Press the [1] key to choose the HDG SOURCE and choose AD-10.
4. Press the [2] key to choose the GC-10 SETTING option.
5. Roll the wheel to set gyrocompass reading.
6. Press the [MENU] key to close the menu.

## 4.2 Memory Card Interface Unit

### Mounting considerations

When selecting a mounting location, keep in mind the following points:

- Locate the memory card interface unit away from heat sources because of heat that can build up inside the cabinet.
- Locate the unit away from places subject to water splash and rain.
- Leave sufficient space at the sides and rear of the unit to facilitate maintenance.
- A magnetic compass will be affected if the unit is placed too close to the magnetic compass. Observe the compass safe distances on page ii to prevent deviation of a magnetic compass.

### Flush mounting

This unit can be flush-mounted in a panel with the standard installation materials.

1. Prepare a cutout in the mounting location, referring to the outline drawing at the end of this manual.
2. Screw in the threaded rods to the flange of the front panel of the unit securely by hands.
3. Set the unit to the cutout.
4. Insert the flat washer, spring washer and nut in that order for each rod and fasten the nuts.

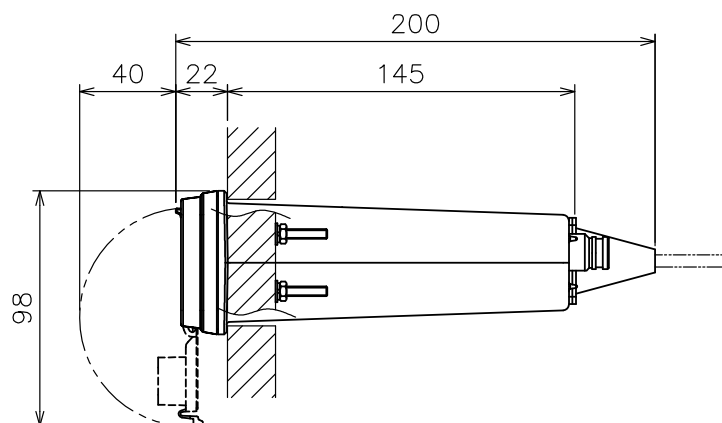
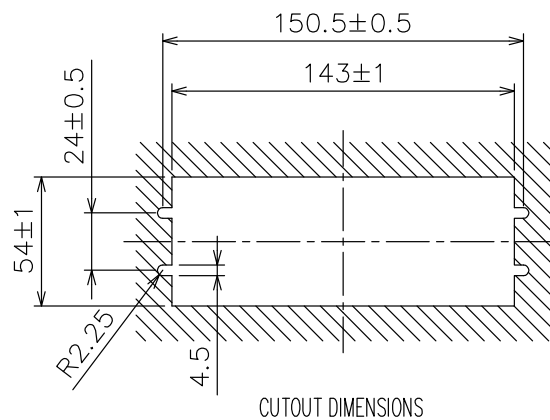

Flush mounting

## 4. INSTALLING OPTIONAL EQUIPMENT

### Desktop mount

For desktop mount, the optional desktop mount kit FP03-10201 is required. Refer to the end of this manual.

1. Fix the mounting bracket 19-023-3081 on the unit with four screws.
2. Mount the above assembly on a desktop with four tapping screws.

### Console mount

For console mount, the optional console mount kit FP03-10202 is required. Refer to the end of this manual.

1. Fix the mounting bracket 19-023-3091 on the unit with four screws.
2. Mount the above assembly to the console with four sets of nut, spring washer and flat washer.

## Connection

### 1) Connection between one processor unit and one memory card IF unit

Connect as shown in the figure below.

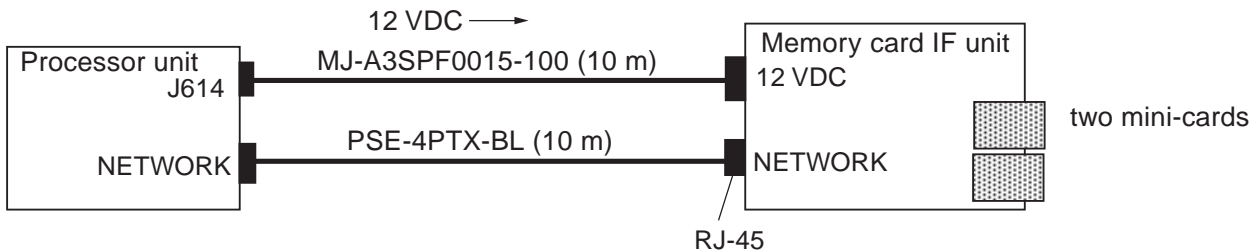

### 2) Connection between one memory card IF unit and multiple processor units

Prepare optional LAN cable kit and switching hub HUB-100. Connect as shown in the next page. Set the radar number on the INSTALLATION menu (see page 3-10), and then turn the power off and on.

#### LAN cable kit

Type	Code No.	Contents
OP03-28900	000-082-658	Cable FR-FTPC-CY (10 m), Modular connector 2 pcs.
OP03-28910	000-082-689	Cable FR-FTPC-CY (20 m), Modular connector 2 pcs.
OP03-28920	000-082-660	Cable FR-FTPC-CY (30 m), Modular connector 2 pcs.

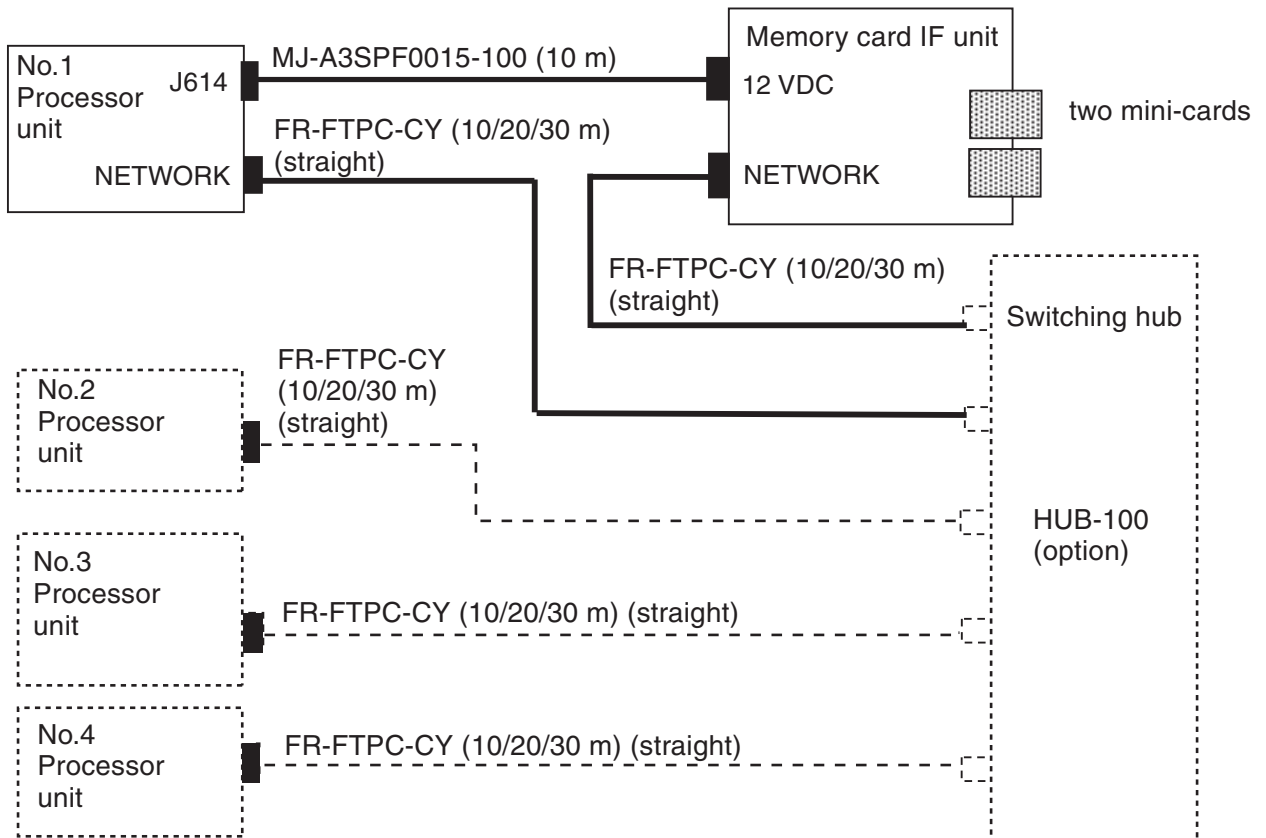

**Note:** When two memory card interface units are connected via network, change ID code for the second unit.

1. Remove the cover and set IP0 bit of the DIP switch S1 to ON on the CARDCPU board 03P9333.
2. Set INIT bit of S1 to ON and turn on the power of the radar. Wait till CR2 starts blinking. Never turn off the power until CR2 starts blinking.
3. Turn off the power and set INIT bit to OFF.

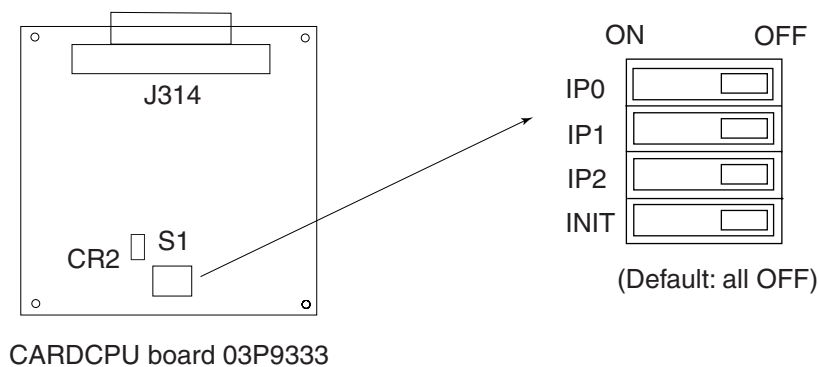

### 4.3 DVI-RGB Conversion Kit (for VDR connection)

This information provides the procedure necessary for the installation of the DVI-RGB conversion kit. This kit is installed in the processor unit to enable connection of a VDR (Voyage Data Recorder) or RGB monitor to record radar pictures into a VDR. When changing the D-sub 15P of the RGB cable to the BNC connector, use the BNC connector converter described on page 4-17. This RGB output complies with the image test defined in the VDR test standard, IEC 61996.

- Name: DVI-RGB conversion kit
- Type: OP03-180-2
- Code no.: 008-536-070
- Resolution: Outputs RGB with the resolution of DVI input.

Display unit	Resolution	DIP switch setting (S-1#1)
MU-201CR	1024x1280	OFF
MU-231CR	1024x1365	ON

Output signal specification: Video; 0.7Vp-p, 75Ω termination, positive polarity  
 Horizontal sync signal; TTL level, negative polarity  
 Vertical sync signal; TTL level, negative polarity

See packing list for contents. Refer to the figure below for modification.

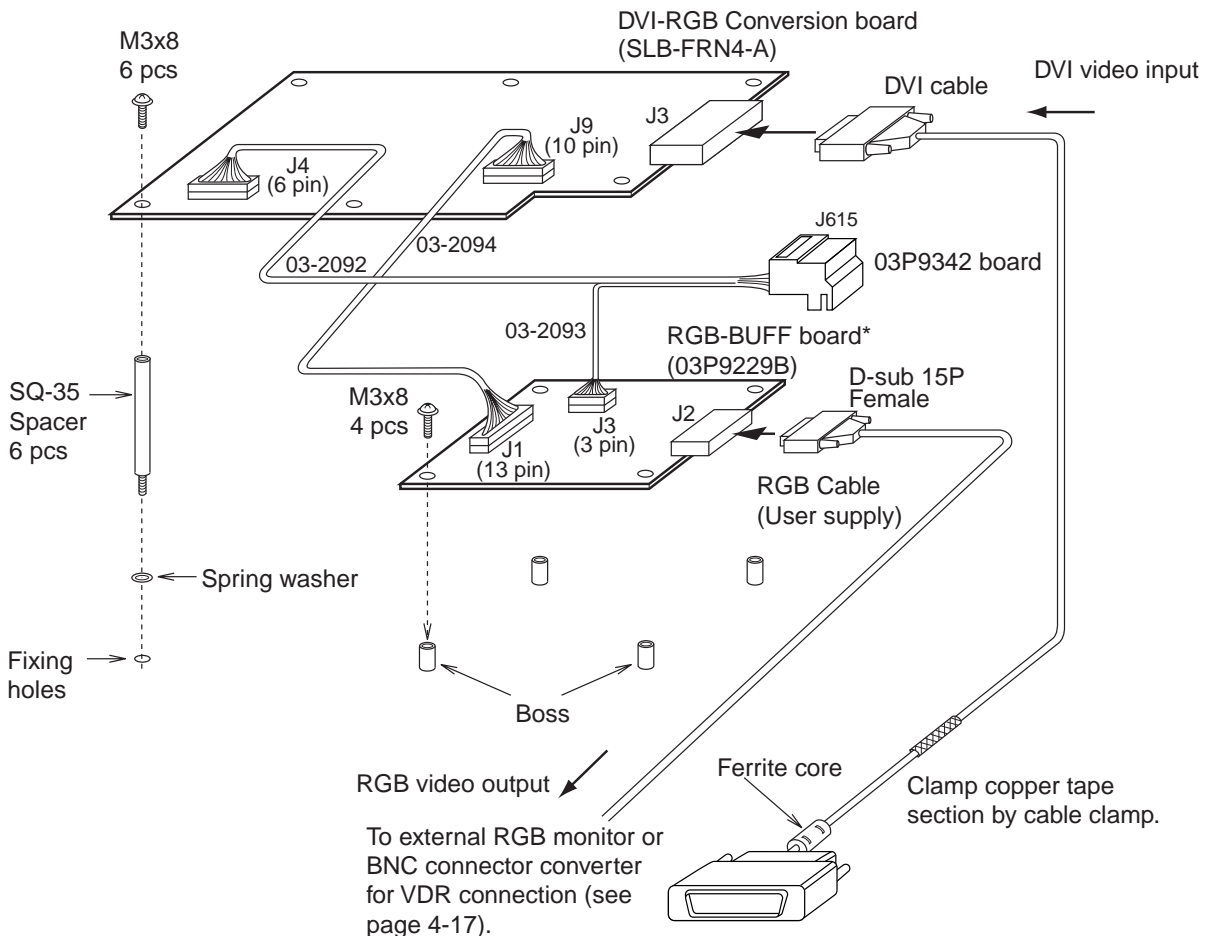

Ferrite core side: Connect to DVI-D port on the upper part of the processor unit.

\*Independent of the MAIN board.



1. Remove the top cover and open the upper part of the processor unit.

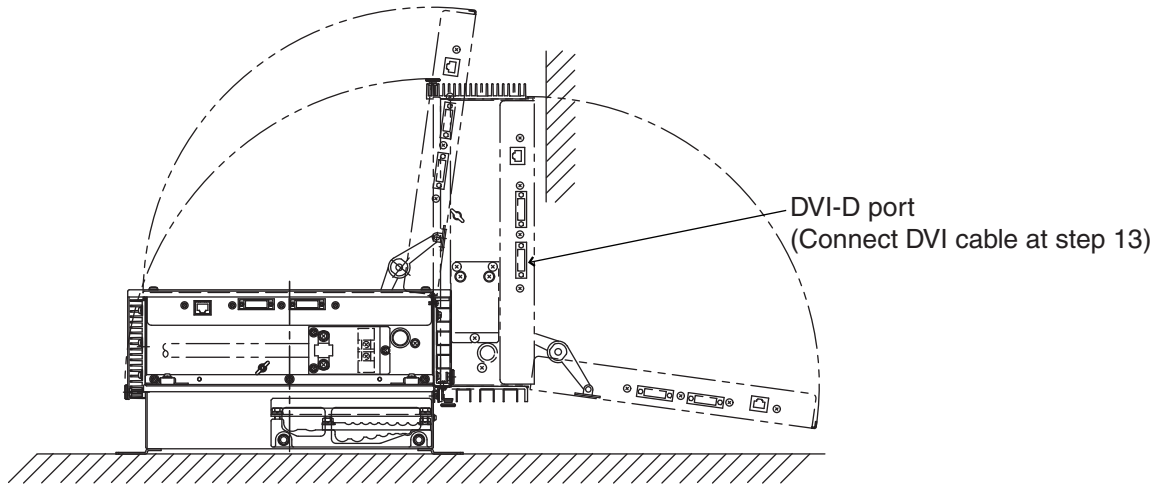

Processor unit

2. Fix the 03P9229B board (RGB-BUFF) with four screws. (See the figure below.)
3. Attach the connector assemblies to J1 and J3 on the 03P9229B board as follows.
  - J1 : 13-pin connector of the connector assembly 03-2094
  - J3 : 3-pin connector of the connector assembly 03-2093
4. Attach six sets of spring washers and spacers to the positions shown below.

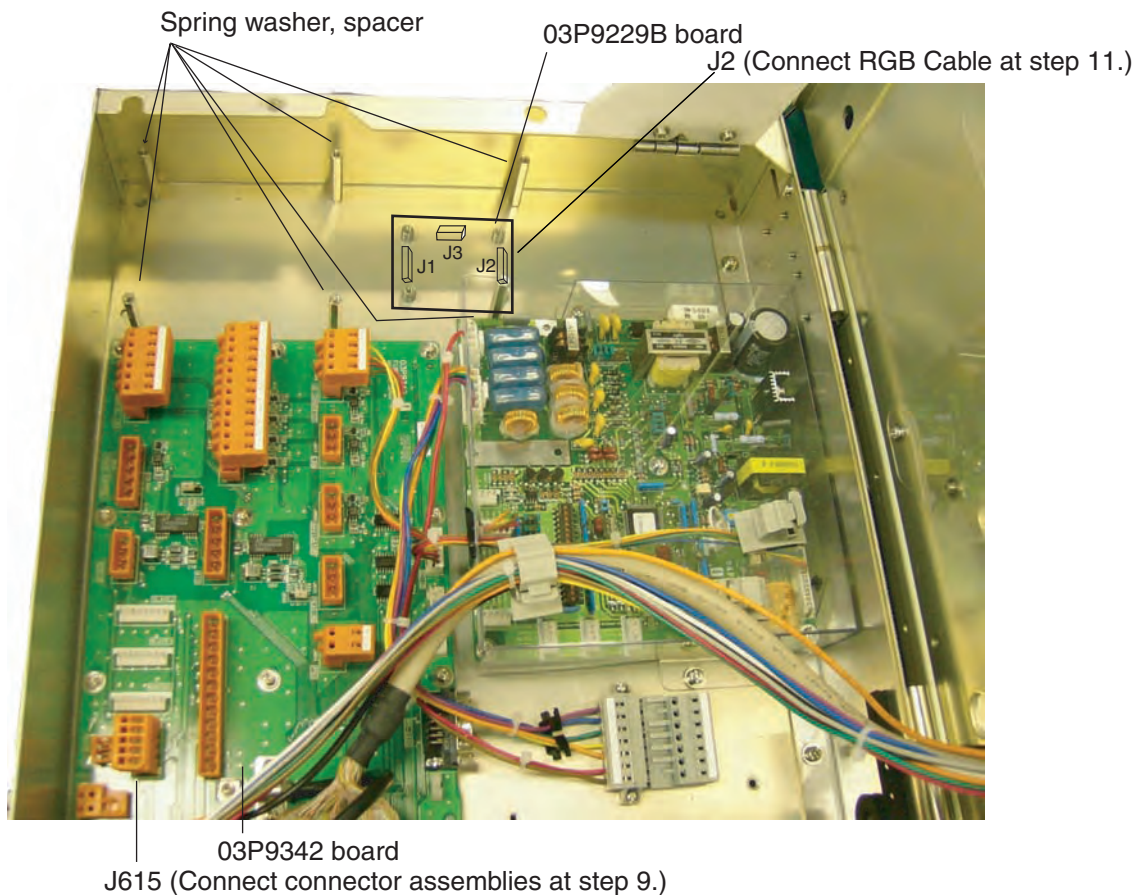

Processor unit (Lower part)

5. Attach the DVI-RGB conversion board to the location shown in the figure on the next page.

## 4. INSTALLING OPTIONAL EQUIPMENT

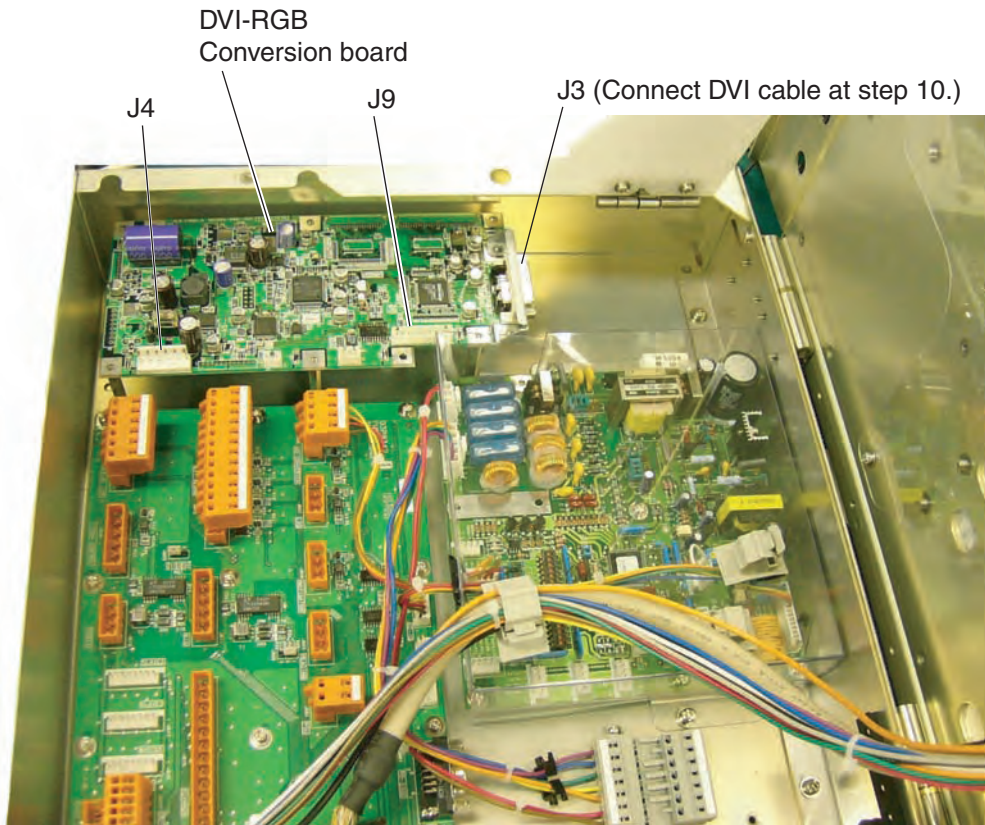

### *Fixing the DVI-RGB conversion board*

6. Attach the 10-pin connector from J1 on the 03P9229B board to J9 on the DVI-RGB board.
7. Attach the connector assembly 03-2092 to J4 on the DVI-RGB conversion board.
8. Remove connector housing J615 from the 03P9342 board. Connect the cable from J3 on the 03P9229B board and the cable from J4 on the DVI-RGB conversion board to J615. After connection, attach J615 to the 03P9342 board.

To connect wires to the connector housing, use the terminal opener (supplied as installation materials) as shown below.

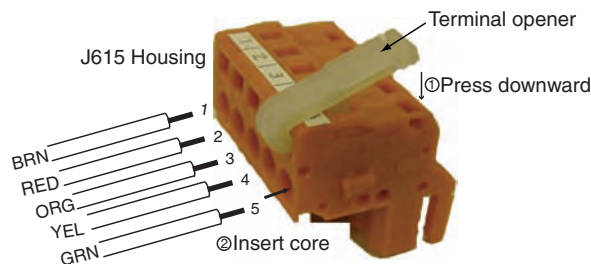

### *Connecting wires to the housing*

9. Connect the DVI cable to J3 on the DVI-RGB conversion board. Connect the end which does not have the ferrite core.
10. Pass an RGB cable (local supply) through the cable clamp and connect it to J2 on the 03P9229B board.
11. Pass the DVI cable through the cable clamp, laying the section with copper tape in the cable clamp.
12. Assemble the processor unit and connect the other end of the DVI cable to DVI-D port.

## 4.4 Performance Monitor PM-31

This kit is installed in the antenna unit of the FAR-2107/2807 series X-band radar to monitor radar performance.

Name: Performance monitor  
 Type: PM-31  
 Code no.: 008-080-438

	Name	Type	Code number	Qty
①	SCANNER COVER ASSY.	PM-31	008-539-430	1
②	GREASE	GASKET GREASE #2 50G	000-149-704	1
③	SM-XH CONNECTOR ASSY.	03-2108 (6P-6P)	008-534-840	1
④	LIFTING FIXTURE	03-001-3264	300-132-640	1
⑤	GASKET	03-001-3263	300-132-631	1

### Procedure

To hoist the scanner cover assy. to the radar mast, by using rope, attach the lifting fixture ④ to the scanner cover assy.①.

1. Remove the bolt and chain at the bottom of the stern-side cover, and then remove the cover.
2. Coat the bolt hole on the scanner cover assy.① with silicone sealant (Adhesive 1211) and secure the chain with the bolt.
3. Remove the cover at the bow side also.
4. Insert the XH connector of the SM-XH connector ③ assy. to J911 on TB board 03P9349 and the SM connector of the SM-XH connector assy. to the relay plate.
5. Coat the gasket ⑤ with the gasket grease #2 50G ② and attach it to the scanner cover assy.①.
6. Connect the cable assembly coming from the scanner cover assy.① to the SM connector attached at step 4 above.
7. Attach the scanner cover assy. to the stern side of the antenna unit.
8. Reattach the bow-side cover.

#### 4. INSTALLING OPTIONAL EQUIPMENT

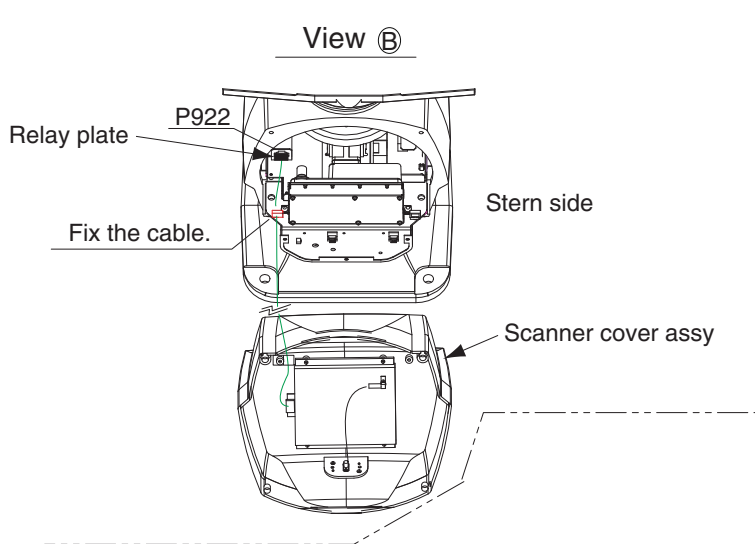

How to fix lifting fixture

1. Insert the lifting fixture as shown below.

Lifting fixture

2. Fix the lifting fixture as shown below.

Upside down the fixture from step 1 and pull it in arrow mark direction.

Note: Fix flat side of the fixture to the coating face.

Lifting fixture

Coating face

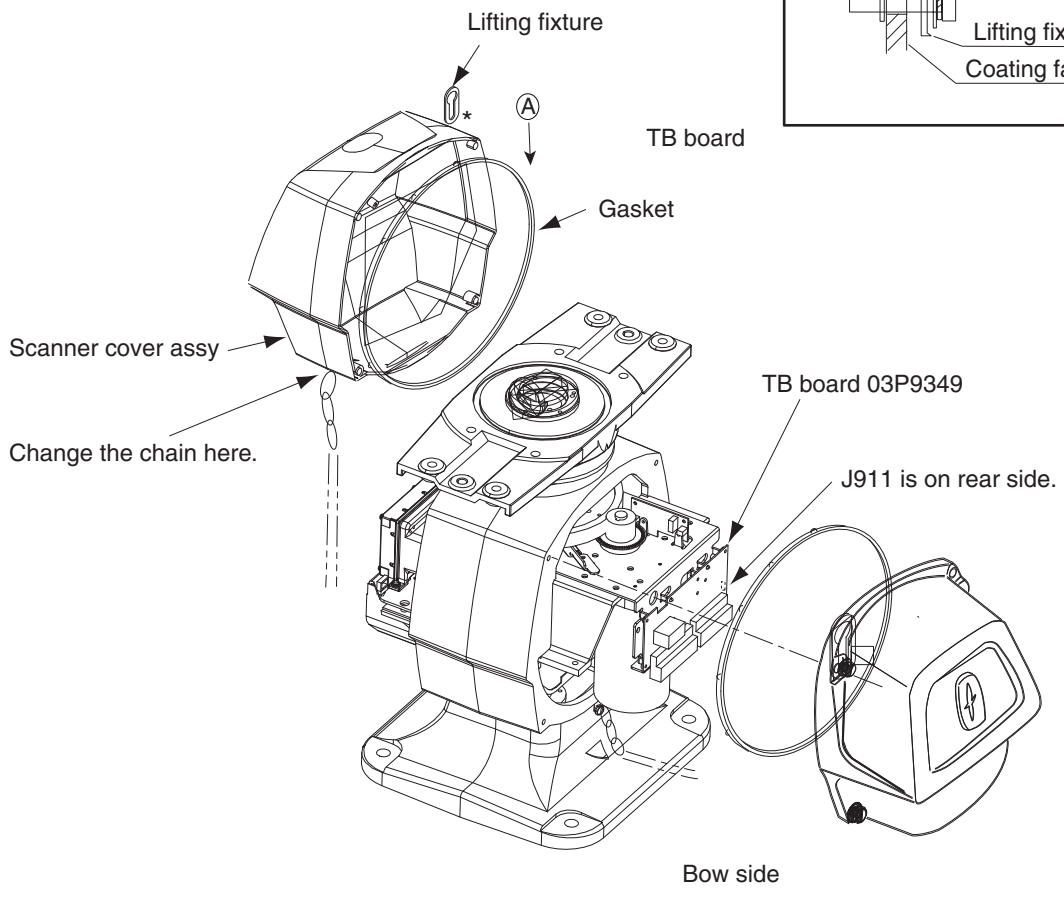

## 4.5 BNC Connector Converter

To connect the VR-5000 (FURUNO Voyage Data Recorder) to this radar, the DVI-RGB conversion kit (mentioned at previous paragraph) and the BNC connector converter are required. Also VGA cable (between the processor unit and the BNC connector converter) and five 75 ohms coaxial cables (between the BNC connector converter and VR-5000) are required.

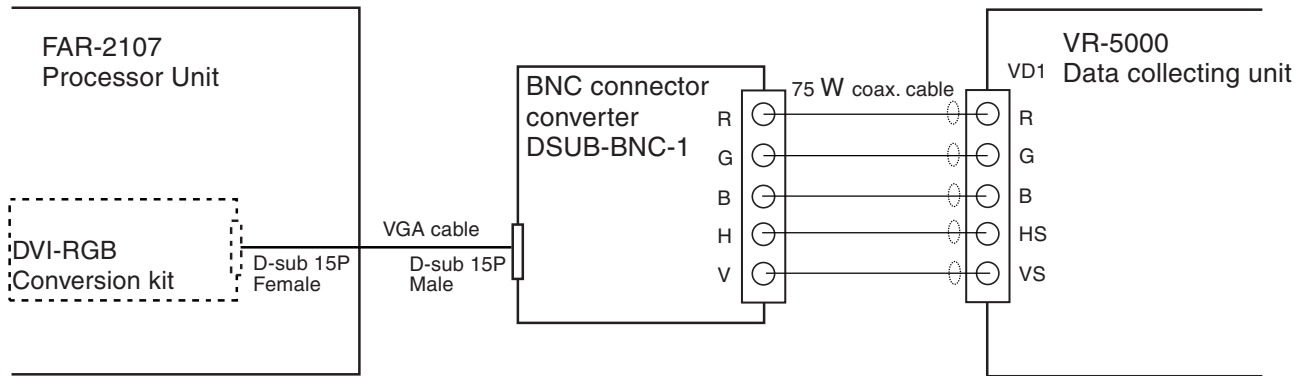

*Interconnection*

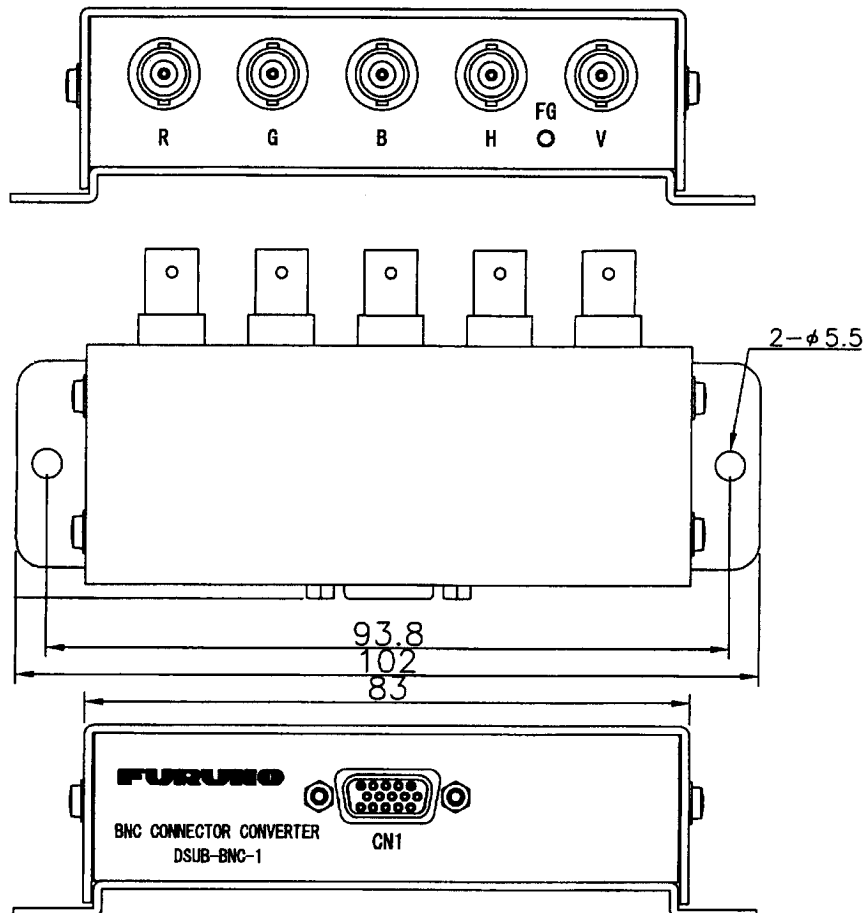

## 4.6 Junction Box

If the length of the antenna cable is more than 100 m, the optional junction boxes are required. These boxes should be mounted at the location protected because its waterproofing is IPX3.

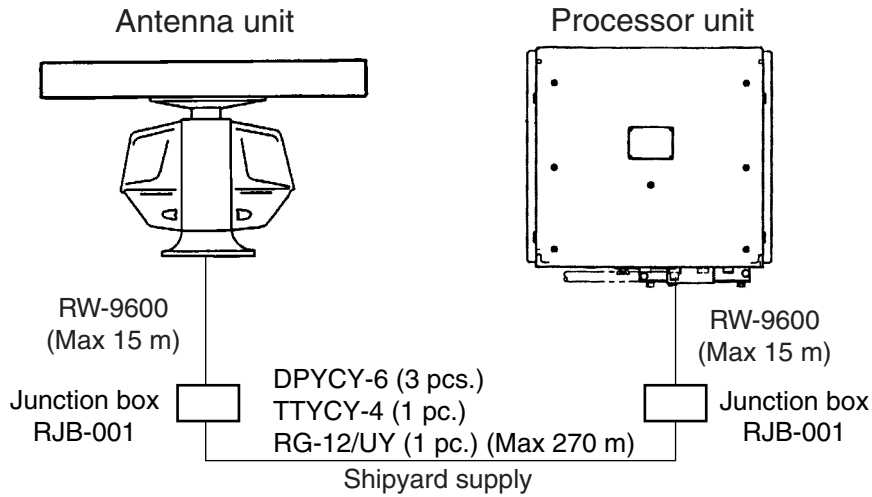

### Mounting

Fasten the junction boxes to the mounting location with four sets of M8 bolt and nut.

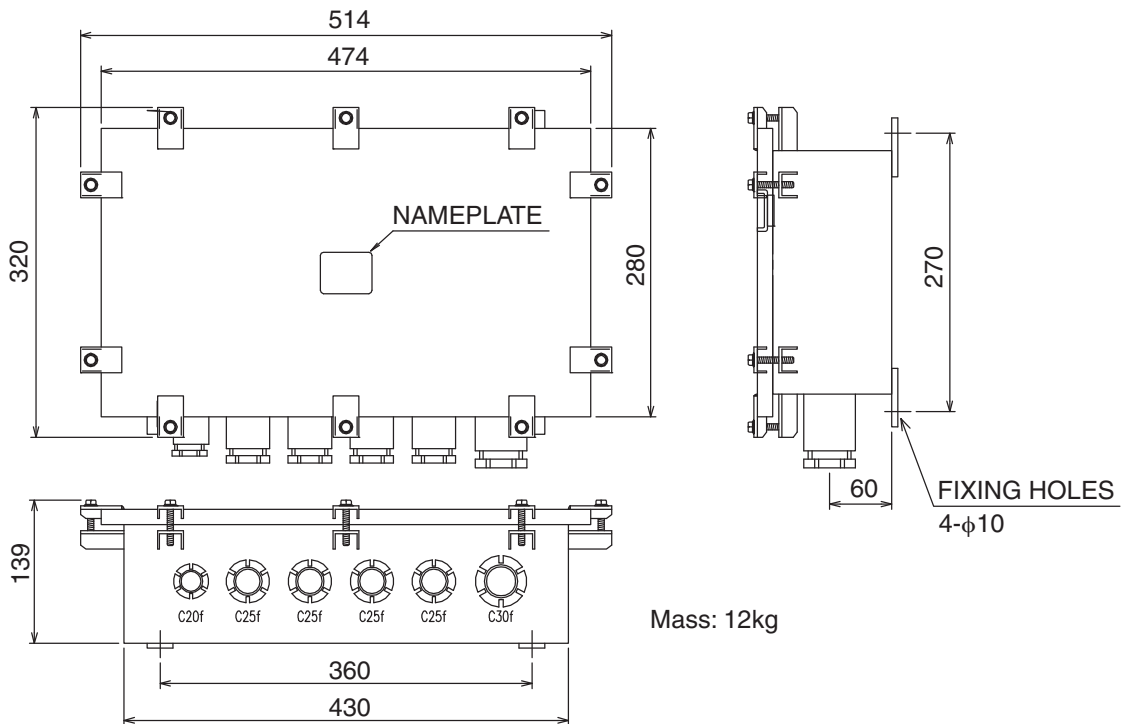



### Cable fabrication

#### RW-9600

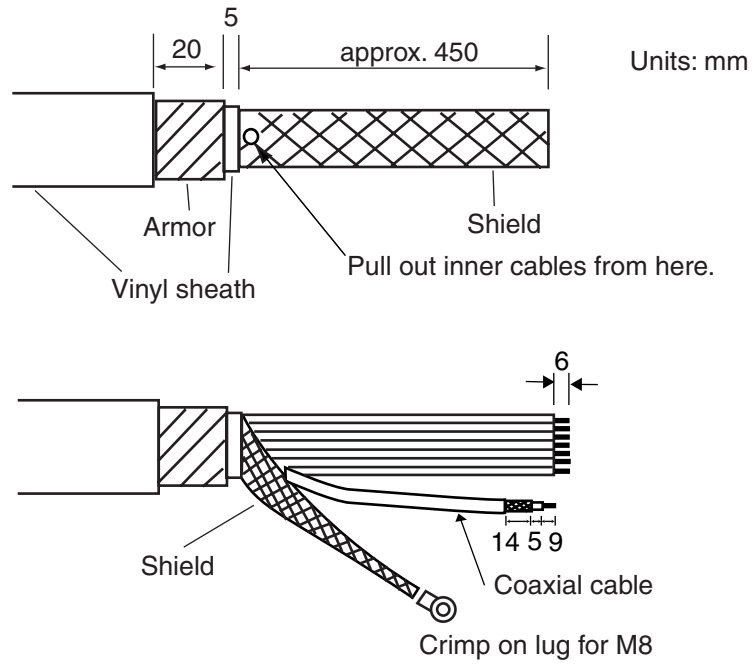

#### DPYC-6 and TTYC-4

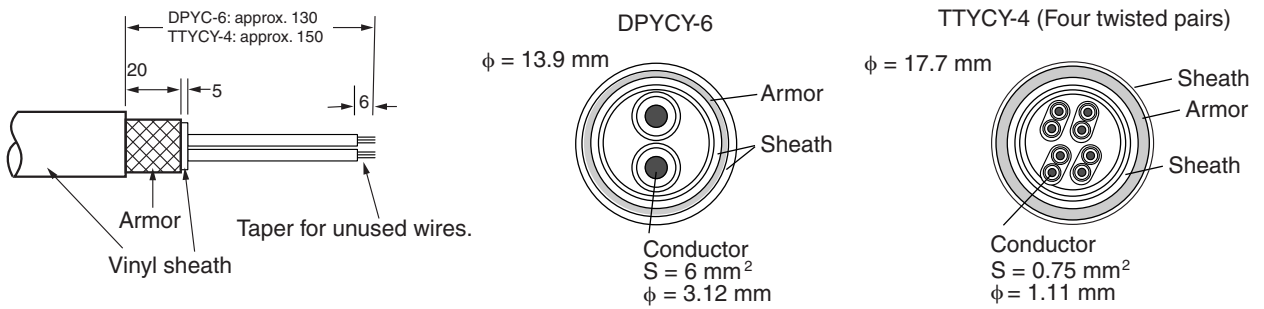

#### RG-12/UJ

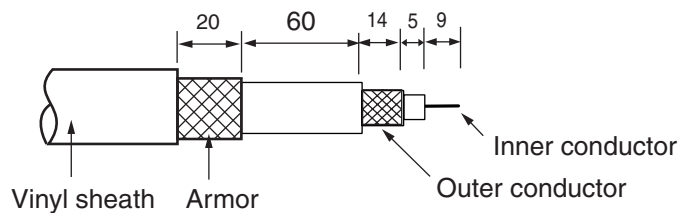

## 4. INSTALLING OPTIONAL EQUIPMENT

### Connection

Insert each cable to the cable gland as follows.

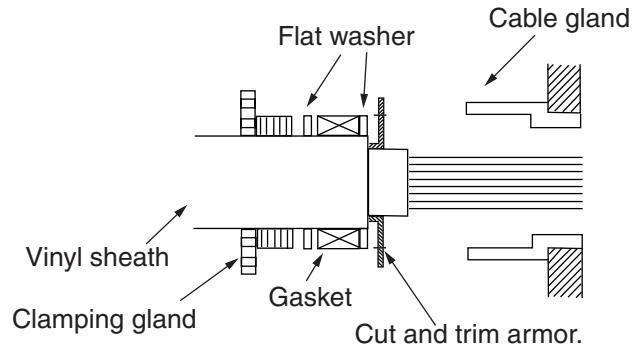

Connect each cable cores to the terminal board, referring to the interconnection diagram on next page.

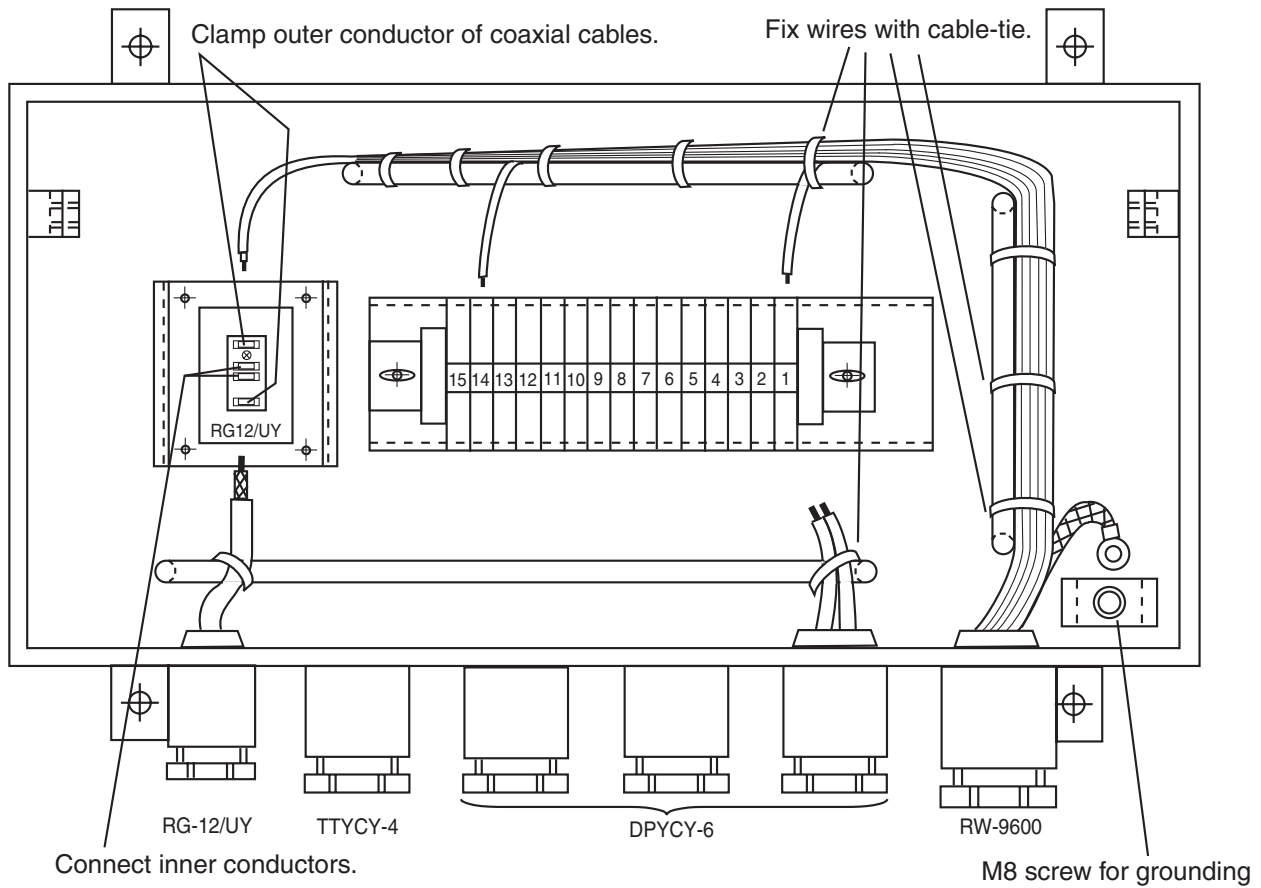



## 4. INSTALLING OPTIONAL EQUIPMENT

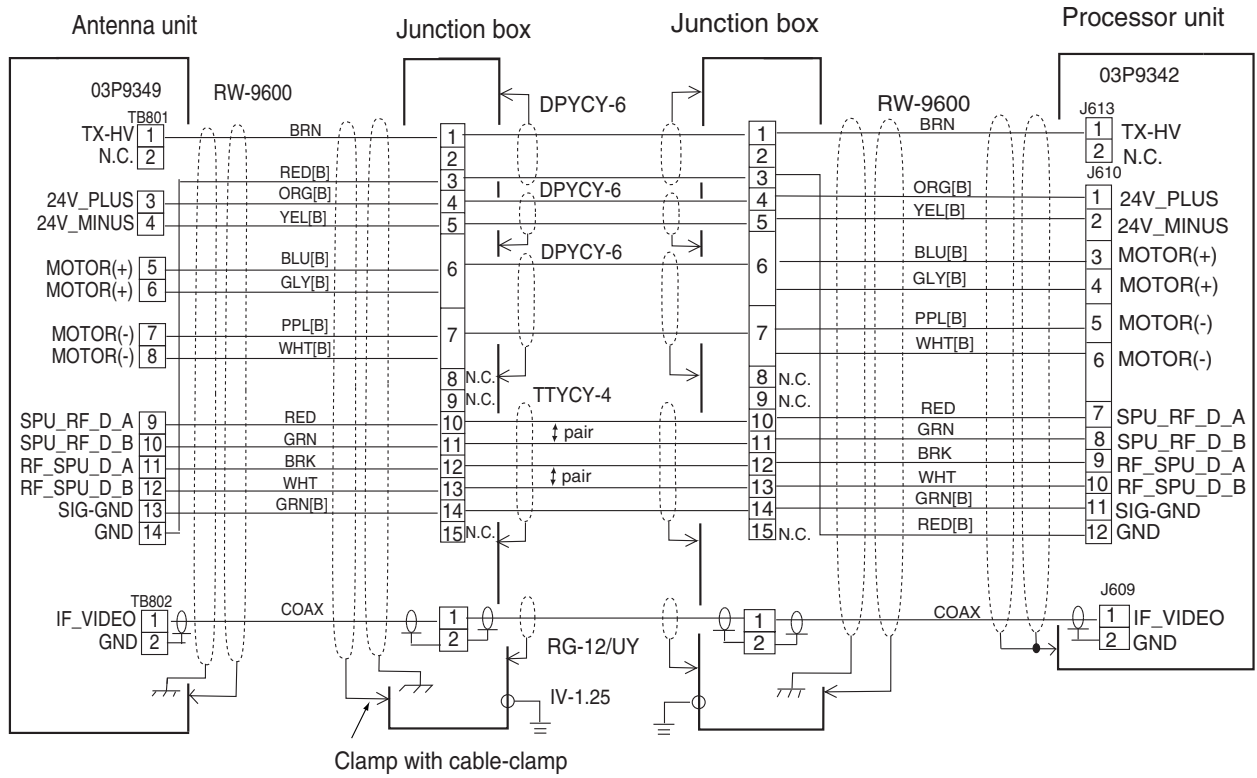

4. INSTALLING OPTIONAL EQUIPMENT

This page is intentionally left blank.

# 5. INPUT/OUTPUT DATA

Input and output data are shown in the table below.

**Note:** This radar accepts position data fixed by WGS-84 geodetic datum only. Set the datum to WGS-84 on the EPFS (GPS, etc.) connected to this radar. If other type of datum is input, the error message "DATUM" appears and the AIS feature is inoperative. Baud rate for the serial input is automatically set to 4800, 9600, 19200 or 38400 as appropriate.

## Input

Data	Specifications	Contents	Remarks
Heading signal	synchro or step	GC-10 required	AD-10 and IEC 61162 are switched by menu setting.
	AD-10 format	External AD-100	
	IEC 61162-2**		
Speed signal	IEC 61162-1		
Navaid data	IEC 61162-1	Position, course, speed, waypoint, route, time, wind data, current data, depth, temperature, roll, pitch	For IMO spec, IEC-61162-1 Edition 2 is required.
External radar signal	Heading, Bearing, Trigger, Video	No STC control	Operate as remote display
Alarm ACK input	Contact closure		Input from alarm system
	IEC61162-1	ACK	Input from alarm system
Track Control unit	RS-422		Option

## Output

Radar system data	RS-232C	RSD, OSD, TLL,	For PC plotter
TT data*	IEC 61162-1	TTD, TTM, TLB	For ECDIS
ALARM data	IEC 61162-1	ALR	For ALARM system
Remote display signal	HD, BP Trigger, Video		2 ports
External LCD monitor signal	DVI	Same as main display unit	2 systems in total
External CRT monitor signal	R, G, B, H, V	Same as main display unit	Option
Alarm signal	Contact closure	Output to alarm system by using photo-relay	4 systems, Output contents are selected by menu.

\*The output sentence, mode and baud rate can be set at the TT Preset menu.

\*\*Data cycle should be input with more than 40 Hz (HSC) or 20 Hz (normal speed).

**IEC 61162 input sentence and priority**

<b>Contents</b>	<b>Sentence and priority</b>
Speed (STW)	VBW>VHW
Speed (SOG)	VBW
Speed (position)	VTG>RMC
Heading (True)	THS*>HDT*
Position	GNS>GGA>RMC>GLL
Datum	DTM
Waypoint	BWR, BWC, RMB
Route	WPL, RTE
Date, Time	ZDA
Depth	DPT >DBT>DBS>DBK
Temperature	MTW
Wind	MWV>VWT>VWR
Set and Drift	VDR
ALARM ACK	ACK









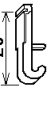

\*: THS and HDT are IEC61162-2  
Others: IEC61162-1 ed2.

**IEC 61162 output sentence**

<b>Contents</b>	<b>Sentence</b>
Target L/L	TLL *
Radar system data	RSD
Own ship data	OSD
TT target data	TTD, TLB, TTM
ALARM data	ALR



\*non IMO-type only.

CODE NO.	008-551-440-00	036L-X-9403-9
TYPE	CP03-25601	

工事材料表		INSTALLATION MATERIALS		CODE NO.		036L-X-9403-9	
番号 NO.	名称 NAME	略図 OUTLINE	型名/規格 DESCRIPTIONS	数量 Q'TY	用途/備考 REMARKS	1/2	
1	防蝕ゴム, 1. CORROSION-PROOF RUBBER		03-001-3001-0 ROHS CODE NO. 300-130-010-10	1			
2	シールワッシャー SEAL WASHER		03-001-3002-0 ROHS CODE NO. 300-130-020-10	4			
3	操作パイプ TERMINAL OPENER		231-131 CODE NO. 000-165-800-10	1			
4	圧着端子 CRIMP-ON LUG		FV5.5-4(LF) CODE NO. 000-166-744-10	1			
5	六角ナット HEXAGONAL NUT		M12 SUS304 CODE NO. 000-167-491-10	4			
6	flat 平座金 FLAT WASHER		M12 SUS304 CODE NO. 000-167-446-10	4			
7	バネ座金 SPRING WASHER		M12 SUS304 CODE NO. 000-167-397-10	4			
8	六角ナット 全ねじ HEXAGON HEAD SCREW		M12X60 SUS304 CODE NO. 000-162-813-10	4			
9	六角ナット HEXAGONAL NUT		M6 SUS304 CODE NO. 000-158-856-10	1			
10	flat 平座金 FLAT WASHER		M6 SUS304 CODE NO. 000-158-854-10	3			

型式/コード番号が2段の場合、下段より上段に代わる標準部品であり、どちらかが入っています。なお、品質は変わりません。  
TWO TYPES AND CODES MAY BE LISTED FOR AN ITEM. THE LOWER PRODUCT MAY BE SHIPPED IN PLACE OF THE UPPER PRODUCT.  
QUALITY IS THE SAME. DIMENSIONS IN DRAWING FOR REFERENCE ONLY.)

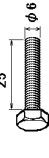
CODE NO.	008-551-440-00	036L-X-9403-9
TYPE	CP03-25601	

工事材料表		INSTALLATION MATERIALS		CODE NO.		036L-X-9403-9	
番号 NO.	名称 NAME	略図 OUTLINE	型名/規格 DESCRIPTIONS	数量 Q'TY	用途/備考 REMARKS	2/2	
11	バネ座金 SPRING WASHER		M6 SUS304 CODE NO. 000-158-855-10	1			
12	六角ナット HEXAGONAL HEAD BOLT		M6X25 SUS304 CODE NO. 000-162-871-10	1			
13	ケーブル組品 CABLE ASSY.		RW-4747 RW-4747-1 CODE NO. 000-566-000-12 000-566-000-01	1			

型式/コード番号が2段の場合、下段より上段に代わる標準部品であり、どちらかが入っています。なお、品質は変わりません。  
TWO TYPES AND CODES MAY BE LISTED FOR AN ITEM. THE LOWER PRODUCT MAY BE SHIPPED IN PLACE OF THE UPPER PRODUCT.  
QUALITY IS THE SAME. DIMENSIONS IN DRAWING FOR REFERENCE ONLY.)

CODE NO.	008-526-380-00	03FS-X-9409-4	1/1
TYPE	CP03-24201		

**工事材料表**

INSTALLATION MATERIALS

番号 NO.	名称 NAME	略図 OUTLINE	型名/規格 DESCRIPTIONS	数量 Q'TY	用途/備考 REMARKS
1	0リング O-RING		JBP-135 CODE NO. 000-808-309-00	1	
2	バネ座金 SPRING WASHER		M8 SUS304 CODE NO. 000-167-410-10	8	
3	六角形平座金 FLAT WASHER		M8 SUS304 CODE NO. 000-167-464-10	8	
4	六角形リブボルト HEXAGONAL HEAD SLOT BOLT		M8X35 SUS304 CODE NO. 000-162-923-10 S-8400W 74571-7 506 S-8400W 74571-7 506	8	
5	シリコン SILICON RUBBER		S-8400W 74571-7 506 CODE NO. 000-158-483-10 000-158-483-00	1	

型式/コード番号が2段の場合、下段より上段に代わる過渡部品であり、どちらかが入っています。なお、品質は変わりません。  
TWO TYPES AND CODES MAY BE LISTED FOR AN ITEM. THE LOWER PRODUCT MAY BE SHIPPED IN PLACE OF THE UPPER PRODUCT.  
QUALITY IS THE SAME. DIMENSIONS IN DRAWING FOR REFERENCE ONLY.)

CODE NO.	008-487-130-00	03FS-X-9403-6	1/1
TYPE	CP03-19101		

**工事材料表**





INSTALLATION MATERIALS

番号 NO.	名称 NAME	略図 OUTLINE	型名/規格 DESCRIPTIONS	数量 Q'TY	用途/備考 REMARKS
1	ピン PIN		03-141-0301-2 ROHS CODE NO. 000-266-882-10	2	
2	0リング O-RING		JBP-135 CODE NO. 000-171-805-10	1	
3	六角形リブ六角ボルト HEX HEAD SLOT BOLT-B WASHER		M8X40 SUS304 CODE NO. 000-162-953-10	8	
4	シリコン SILICON RUBBER		S-8400W 74571-7 506 CODE NO. 000-158-483-10 000-158-483-00	1	

型式/コード番号が2段の場合、下段より上段に代わる過渡部品であり、どちらかが入っています。なお、品質は変わりません。  
TWO TYPES AND CODES MAY BE LISTED FOR AN ITEM. THE LOWER PRODUCT MAY BE SHIPPED IN PLACE OF THE UPPER PRODUCT.  
QUALITY IS THE SAME. DIMENSIONS IN DRAWING FOR REFERENCE ONLY.)

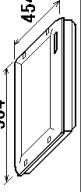
# PACKING LIST

MU-201CR-\*

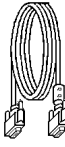



NAME	OUTLINE	DESCRIPTION/CODE No.	Q'TY
<b>ユニット</b>			
表示部 DISPLAY UNIT		MU-201CR-**-S/**-HK-AT 000-083-054-00	1
<b>予備品</b>			
予備品 SPARE PARTS		SP03-03900 000-081-063-00	1 DC用
<b>予備品</b>			
予備品 SPARE PARTS		SP03-14401 008-535-990-00	1 AC用
<b>付属品</b>			
付属品 ACCESSORIES		FP03-09810 008-536-010-00	1
<b>工事材料</b>			
ケーブル組品 CABLE ASSY.		DVI-D/D SINGLE LINK 5M 000-149-054-10	1

1.コード末尾に[\*\*]の付いたユニットは代表の型式/コードを表示しています。  
DOUBLE ASTERISK DENOTES COMMONLY USED EQUIPMENT.  
2.予備品は、AC用/DC用で選択願います。  
CHOOSE SPARE PARTS DEPENDING ON AC OR DC POWER.

型式/コード番号が2段の場合、下段より上段に代わる過渡期品であり、どちらが入っています。なお、品質は変わりません。  
TWO TYPES AND CODES MAY BE LISTED FOR AN ITEM. THE LOWER PRODUCT MAY BE SHIPPED IN PLACE OF THE UPPER PRODUCT. QUALITY IS THE SAME.  
(略図の寸法は、参考値です。 DIMENSIONS IN DRAWING FOR REFERENCE ONLY.)

03GL-X-9855

# FURUNO

CODE NO.	TYPE	03GL-X-9401-6	1/1
FAR-21**/28**, FOR-21**/28**			
工事材料表 INSTALLATION MATERIALS	略図 OUTLINE	型名/規格 DESCRIPTIONS	数量 Q'TY
1 ケーブル(14C) 14-CORE CABLE		RW-9600 *15M* CODE NO. 001-078-400-10	1 選択 TO BE SELECTED 標準ケーブル SIGNAL CABLE
2 ケーブル(14C) 14-CORE CABLE		RW-9600 *30M* CODE NO. 001-078-410-10	1 選択 TO BE SELECTED 標準ケーブル SIGNAL CABLE
3 ケーブル(14C) 14-CORE CABLE		RW-9600 *40M* CODE NO. 001-078-420-10	1 選択 TO BE SELECTED 標準ケーブル SIGNAL CABLE
4 ケーブル(14C) 14-CORE CABLE		RW-9600 *50M* CODE NO. 001-078-430-10	1 選択 TO BE SELECTED 標準ケーブル SIGNAL CABLE

型式/コード番号が2段の場合、下段より上段に代わる過渡期品であり、どちらが入っています。なお、品質は変わりません。  
TWO TYPES AND CODES MAY BE LISTED FOR AN ITEM. THE LOWER PRODUCT MAY BE SHIPPED IN PLACE OF THE UPPER PRODUCT.  
QUALITY IS THE SAME.  
(略図の寸法は、参考値です。 DIMENSIONS IN DRAWING FOR REFERENCE ONLY.)

FURUNO ELECTRIC CO., LTD.

03GL-X-9401

# FURUNO



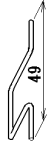
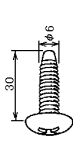

## 付属品表

ACCESSORIES		For MU-201CR		CODE NO.	008-536-010-00	03GL-X-9504-4	1/1
番号 NO.	名称 NAME	略図 OUTLINE	型名/規格 DESCRIPTIONS	数量 Q'TY	用途/備考 REMARKS		
1	パネルカバー PANEL COVER		03-163-1101-1 ROHS CODE NO. 100-305-111-10	4	表示部用 FOR DISPLAY UNIT		
2	パネルフック PANEL HOOK		03-163-1102-0 ROHS CODE NO. 100-305-120-10 100-305-120-00	2	表示部用 FOR DISPLAY UNIT		
3	1/2インチ セルフタップングネジ SELF-TAPPING SCREW		6X30 SUS304 CODE NO. 000-162-614-10	4	表示部用 FOR DISPLAY UNIT		

型式/コード番号が2段の場合、下段より上段に代わる過渡部品であり、どちらが入っています。なお、品質は変わりません。  
TWO TYPES AND CODES MAY BE LISTED FOR AN ITEM. THE LOWER PRODUCT MAY BE SHIPPED IN PLACE OF THE UPPER PRODUCT.  
QUALITY IS THE SAME. DIMENSIONS IN DRAWING FOR REFERENCE ONLY.)  
(略図の寸法は、参考値です。)

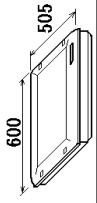
# PACKING LIST

## MU-231CR-\*

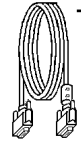
NAME	OUTLINE	DESCRIPTION/CODE No.	Q'TY
<b>ユニット</b>			
表示部 DISPLAY UNIT		MU-231CR-S/*-HK-AR 000-080-430-00 ***	1
<b>予備品</b>			
予備品 SPARE PARTS		SPO3-14401 008-535-990-00	1 AC用
<b>予備品</b>			
予備品 SPARE PARTS		SPO3-14402 008-536-000-00	1 DC用
<b>付属品</b>			
付属品 ACCESSORIES		FPO3-09810 008-536-010-00	1
<b>工事材料</b>			
ケーブル組品 CABLE ASSY.		DVI-D/D SINGLE LINK 5M 000-149-054-10	1

1.コード末尾に[\*]の付いたユニットは代表の型式/コードを表示しています。  
DOUBLE ASTERISK DENOTES COMMONLY USED EQUIPMENT.  
2.予備品は、ACDCで選択願います。  
CHOOSE SPARE PARTS DEPENDING ON AC OR DC POWER.

型式/コード番号が2段の場合、下段より上段に代わる過渡部品であり、どちらが入っています。なお、品質は変わりません。  
TWO TYPES AND CODES MAY BE LISTED FOR AN ITEM. THE LOWER PRODUCT MAY BE SHIPPED IN PLACE OF THE UPPER PRODUCT. QUALITY IS THE SAME.  
(略図の寸法は、参考値です。 DIMENSIONS IN DRAWING FOR REFERENCE ONLY.)



# PACKING LIST

RPU-013

A-9  
036L-X-9858 -7 1/1

NAME	OUTLINE	DESCRIPTION/CODE No.	QTY
<b>ユニット</b>			
制御部 PROCESSOR UNIT		RPU-013* 000-081-381-00 **	1
<b>予備品</b>			
予備品 SPARE PARTS		SPO3-14404 008-535-910-00	1 (*1)
予備品 SPARE PARTS		SPO3-14405 008-535-920-00	1 (*1)
予備品 SPARE PARTS		SPO3-14406 008-535-930-00	1 (*1)
<b>工事材料</b>			
<b>INSTALLATION MATERIALS</b>			
工事材料 INSTALLATION MATERIALS		CP03-25602 008-535-940-00	1 (*2)
工事材料 INSTALLATION MATERIALS		CP03-25603 008-535-950-00	1 (*2)
<b>図書</b>			
<b>DOCUMENT</b>			
取扱説明書 OPERATOR'S MANUAL		OM*-35190-* 000-147-451-1* **	1
取扱説明書 OPERATOR'S MANUAL		OM*-35221-* 000-164-255-1* **	1 (*3)
装備要領書 INSTALLATION MANUAL		IM*-35***-* 000-148-692-1* **	1
操作要領書 OPERATOR'S GUIDE		OS*-35190-* 000-153-046-1* **	1

1.コード番号末尾の「\*」は、選択品の代表コードを意味します。  
CODE NUMBER ENDING WITH "\*" INDICATES THE CODE NUMBER OF REPRESENTATIVE MATERIAL.

2. (\*1) (\*2) は、それぞれ仕様選択品を意味します。  
(\*1) (\*2) INDICATE SPECIFICATION SELECTIVE ITEM.  
3. (\*3) FAR-2157/2167DS仕様時のみ添付されます。  
SUPPLIED WITH FAR-2157/2167DS ONLY.

型式/コード番号が2段の場合、下段より上段に代わる過渡期品であり、どちらかが入っています。なお、品質は変わりません。  
TWO TYPES AND CODES MAY BE LISTED FOR AN ITEM. THE LOWER PRODUCT MAY BE SHIPPED IN PLACE OF THE UPPER PRODUCT. QUALITY IS THE SAME.  
(略図の寸法は、参考値です。 DIMENSIONS IN DRAWING FOR REFERENCE ONLY.)

036L-X-9858

A-10

# FURUNO



CODE NO.	008-535-940-00	036L-X-9405 -2			
TYPE	CP03-25602	1/1			
AC用					
<b>工事材料表</b>					
INSTALLATION MATERIALS					
番号 NO.	名称 NAME	略図 OUTLINE	型名/規格 DESCRIPTIONS	数量 QTY	用途/備考 REMARKS
1	操作バネ TERMINAL OPENER		231-131 CODE NO. 000-165-800-10	1	制御部用 FOR PROCESSOR UNIT
2	操作バネ TERMINAL OPENER		734-230 CODE NO. 000-147-417-10	1	制御部用 FOR PROCESSOR UNIT
3	圧着端子 CRIMP-ON LUG		FV2-4 CODE NO. 000-157-247-10	2	制御部用 FOR PROCESSOR UNIT

型式/コード番号が2段の場合、下段より上段に代わる過渡期品であり、どちらかが入っています。なお、品質は変わりません。  
TWO TYPES AND CODES MAY BE LISTED FOR AN ITEM. THE LOWER PRODUCT MAY BE SHIPPED IN PLACE OF THE UPPER PRODUCT. QUALITY IS THE SAME.  
(略図の寸法は、参考値です。 DIMENSIONS IN DRAWING FOR REFERENCE ONLY.)

FURUNO ELECTRIC CO., LTD.

036L-X-9405



**FURUNO**

CODE NO.		008-535-950-00		036L-X-9406-2	
TYPE		CP03-25603		1/1	
DC用					
番号 NO.	名称 NAME	略図 OUTLINE	型名/規格 DESCRIPTIONS	数量 Q'TY	用途/備考 REMARKS
1	操作バネ TERMINAL OPENER		231-131 CODE NO. 000-165-800-10	1	制御部用 FOR PROCESSOR UNIT
2	操作バネ TERMINAL OPENER		734-230 CODE NO. 000-147-417-10	1	制御部用 FOR PROCESSOR UNIT
3	圧着端子 CRIMP-ON LUG		FV5.5-4 (LF) CODE NO. 000-166-744-10	2	制御部用 FOR PROCESSOR UNIT

型式/コード番号が2段の場合、下段より上段に代わる通線部品であり、どちらかが入っています。なお、品質は変わりません。  
TWO TYPES AND CODES MAY BE LISTED FOR AN ITEM. THE LOWER PRODUCT MAY BE SHIPPED IN PLACE OF THE UPPER PRODUCT. QUALITY IS THE SAME.  
(略図の寸法は、参考値です。 DIMENSIONS IN DRAWING FOR REFERENCE ONLY.)

FURUNO ELECTRIC CO., LTD. 036L-X-9406

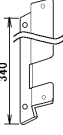
**FURUNO**

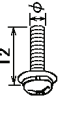
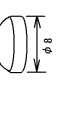
CODE NO.		008-535-610-00		036L-X-9505-7	
TYPE		FP03-09850		1/1	
For RCU-014 Desktop mount kit					
番号 NO.	名称 NAME	略図 OUTLINE	型名/規格 DESCRIPTIONS	数量 Q'TY	用途/備考 REMARKS
1	KB直付金具 KB FIXING METAL		03-163-7521-1 ROHS CODE NO. 100-306-251-10	1	操作部用 FOR CONTROL UNIT
2	ゴムパッキン GROMMET		G-39 CODE NO. 000-166-401-10	1	操作部用 FOR CONTROL UNIT
3	ワッシャー WASHER HEAD SCREW *B*		MAX12 C2700W M8N12 CODE NO. 000-163-192-10	2	操作部用 FOR CONTROL UNIT
4	クッション CUSHION		TM-180-302 CODE NO. 000-166-468-10	3	操作部用 FOR CONTROL UNIT

型式/コード番号が2段の場合、下段より上段に代わる通線部品であり、どちらかが入っています。なお、品質は変わりません。  
TWO TYPES AND CODES MAY BE LISTED FOR AN ITEM. THE LOWER PRODUCT MAY BE SHIPPED IN PLACE OF THE UPPER PRODUCT. QUALITY IS THE SAME.  
(略図の寸法は、参考値です。 DIMENSIONS IN DRAWING FOR REFERENCE ONLY.)



FURUNO ELECTRIC CO., LTD. 036L-X-9505

# FURUNO

## 付属品表

For RCU-015/016 Desktop mount kit

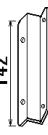
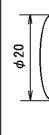
For RCU-014/015/016 Flush mount kit

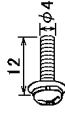
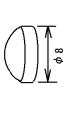
番号 NO.	名称 NAME	略図 OUTLINE	型名/規格 DESCRIPTIONS	数量 Q'TY	用途/備考 REMARKS
1	キーボード金具(T) KEYBOARD FIXTURE		03-163-7821-1 ROHS CODE NO. 100-306-291-10	1	操作部用 FOR CONTROL UNIT
2	ブラインドシール BLIND SEAL		22-020-1005-1 ROHS CODE NO. 100-773-591-10	3	操作部用 FOR CONTROL UNIT
3	グロメット GROMMET		G-49 CODE NO. 000-166-406-10	1	操作部用 FOR CONTROL UNIT
4	ワッシャー WASHER HEAD SCREW *B*		MAX12 G2700W MBN12 CODE NO. 000-163-192-10	2	操作部用 FOR CONTROL UNIT
5	リバーフット RUBBER FOOT		TM-180-302 CODE NO. 000-166-468-10	2	操作部用 FOR CONTROL UNIT





型式/コード番号が2段の場合、下段より上段に代わる過渡製品であり、どちらかが入っています。なお、品質は変わりません。  
TWO TYPES AND CODES MAY BE LISTED FOR AN ITEM. THE LOWER PRODUCT MAY BE SHIPPED IN PLACE OF THE UPPER PRODUCT. QUALITY IS THE SAME.  
(略図の寸法は、参考値です。 DIMENSIONS IN DRAWING FOR REFERENCE ONLY.)

FURUNO ELECTRIC CO., LTD. 036L-X-9506

# FURUNO

## 付属品表

For RCU-014/015/016 Flush mount kit

番号 NO.	名称 NAME	略図 OUTLINE	型名/規格 DESCRIPTIONS	数量 Q'TY	用途/備考 REMARKS
1	フラッシュマウント金具 FLUSH MOUNTING PLATE		03-163-7531-1 ROHS CODE NO. 100-306-261-10	4	
2	ワッシャー WASHER HEAD SCREW *B*		MAX12 G2700W MBN12 CODE NO. 000-163-192-10	4	
3	六角ナット HEX. NUT		M6 SUS304 CODE NO. 000-165-921-10	4	
4	蝶ネジ WING SCREW		MX40 SUS304 CODE NO. 000-162-682-10	4	

Option

型式/コード番号が2段の場合、下段より上段に代わる過渡製品であり、どちらかが入っています。なお、品質は変わりません。  
TWO TYPES AND CODES MAY BE LISTED FOR AN ITEM. THE LOWER PRODUCT MAY BE SHIPPED IN PLACE OF THE UPPER PRODUCT. QUALITY IS THE SAME.  
(略図の寸法は、参考値です。 DIMENSIONS IN DRAWING FOR REFERENCE ONLY.)

FURUNO ELECTRIC CO., LTD. 036L-X-9503

ACCESSORIES		CODE NO.	008-535-570-00	036L-X-9502-3	1/1
		TYPE	FP03-09840		
番号 NO.	名称 NAME	略図 OUTLINE	型名/規格 DESCRIPTIONS	数量 QTY	用途/備考 REMARKS
1	取手 HANDLE		14-002-1125-2 ROHS CODE NO. 840-211-2652-10	2	
2	ロゼット外座金 ROSETTE WASHER		M6 C2700W ホリソール CODE NO. 000-165-694-10 000-864-910-00	4	
3	+丸皿外ネジ OVAL HEAD SCREW		M6X20 C2700W ホリソール CODE NO. 000-163-677-10	4	
4	波座金 WAVE WASHER		W6-6 SUS CODE NO. 000-167-384-10	4	

型式/コード番号が2段の場合、下段より上段に代わる過渡部品であり、どちらが入っています。なお、品質は変わりません。  
 TWO TYPES AND CODES MAY BE LISTED FOR AN ITEM. THE LOWER PRODUCT MAY BE SHIPPED IN PLACE OF THE UPPER PRODUCT. QUALITY IS THE SAME.  
 (略図の寸法は、参考値です。)







NAME	UNIT	OUTLINE	DESCRIPTION/CODE No.	QTY
ユニット メモリーカードインターフェイス			CU-200	1
工事材料 MEMORY CARD INTERFACE			000-081-569-00	
工事材料 INSTALLATION MATERIALS				
工事材料 INSTALLATION MATERIALS			CP03-27431	1
工事材料 INSTALLATION MATERIALS			008-544-400-00	
その他工材 OTHER INSTALLATION MATERIALS				
ケーブル組品 CABLE ASSY.			P5E-4PTY-BL P5E-4PTY-BL 000-164-637-10 000-147-510-00	1
ケーブル組品 CABLE ASSY.			MJ-AS3PF0015-100C 000-156-054-11	1

型式/コード番号が2段の場合、下段より上段に代わる過渡部品であり、どちらが入っています。なお、品質は変わりません。  
 TWO TYPES AND CODES MAY BE LISTED FOR AN ITEM. THE LOWER PRODUCT MAY BE SHIPPED IN PLACE OF THE UPPER PRODUCT. QUALITY IS THE SAME.  
 (略図の寸法は、参考値です。)

CODE NO.	008-544-400-00	0360-X-9404-6
TYPE	CP03-27431	1/1

**工事材料表**

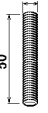
INSTALLATION MATERIALS



番号 NO.	名称 NAME	略図 OUTLINE	型名/規格 DESCRIPTIONS	数量 Q'TY	用途/備考 REMARKS
1	舵輪貼りマーク (BSH) STEERING WHEEL LABEL		03-801-0851-4 CODE NO. 100-277-724-10	1	
2	ハネ座金 SPRING WASHER		M4 SUS304 CODE NO. 000-167-405-10	4	
3	ミガキ丸平座金 FLAT WASHER		M4 SUS304 CODE NO. 000-167-455-10	4	
4	六角ナット HEX NUT		M4 SUS304 CODE NO. 000-167-488-10	4	
5	寸切棒 THREADED ROD		M4X50 SUS304 CODE NO. 000-162-679-10	4	
6	舵輪マーク貼付要領 LABEL ATTACHING PROCEDURE		G32-00407-4 7/14 CODE NO. 000-150-918-1*	1	

型式/コード番号が2段の場合、下段より上段に代わる通称部品であり、どちらが入っています。なお、品質は変わりません。  
TWO TYPES AND CODES MAY BE LISTED FOR AN ITEM. THE LOWER PRODUCT MAY BE SHIPPED IN PLACE OF THE UPPER PRODUCT. QUALITY IS THE SAME.  
(略図の寸法は、参考値です。 DIMENSIONS IN DRAWING FOR REFERENCE ONLY.)

CODE NO.	008-539-530-00	0360-X-9502-3
TYPE	FP03-10201	1/1

**付属品表**

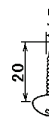
ACCESSORIES

番号 NO.	名称 NAME	略図 OUTLINE	型名/規格 DESCRIPTIONS	数量 Q'TY	用途/備考 REMARKS
1	ハゴ MOUNTING BRACKET		19-023-3081-0 CODE NO. 100-316-250-10	1	
2	+ワザカビナボ SELF-TAPPING SCREW		5X20 SUS304 CODE NO. 000-162-608-10	4	
3	+ワザ WASHER HEAD SCREW		M4X10 C2700W MBN12 CODE NO. 000-163-167-10	4	

型式/コード番号が2段の場合、下段より上段に代わる通称部品であり、どちらが入っています。なお、品質は変わりません。  
TWO TYPES AND CODES MAY BE LISTED FOR AN ITEM. THE LOWER PRODUCT MAY BE SHIPPED IN PLACE OF THE UPPER PRODUCT. QUALITY IS THE SAME.  
(略図の寸法は、参考値です。 DIMENSIONS IN DRAWING FOR REFERENCE ONLY.)

A-20

NAME	OUTLINE	DESCRIPTION/CODE No.	Q'TY
<b>予備品 SPARE PARTS</b>			
予備品 SPARE PARTS		SP03-13300 008-419-280-00	1
<b>その他部品 OTHER PARTS</b>			
GCカバー組品 GC COVER ASSY.		80-0665 008-537-030-00	1
NHコネクタ NH CONNECTOR ASSY.		03-2091 (5P) 008-534-670-00	1
VHコネクタ VH CONNECTOR ASSY.		03-2090 (3P) 008-534-660-00	1
VHコネクタ VH CONNECTOR ASSY.		03-2089 (5P) 008-534-650-00	1
XH-PHコネクタ XH-PH CONNECTOR ASSY.		03-2088 (6-14P) 008-534-640-00	1
演算プリント PROCESSOR BOARD		64P1106A (LF) 004-655-920-00	1
ナハセムスB WASHER HEAD SCREW (B)		M4X8 C2700W MBN12 000-163-200-10	3

NAME	OUTLINE	DESCRIPTION/CODE No.	Q'TY
ナハセムスB WASHER HEAD SCREW		M3X8 C2700W MBN12 000-163-190-10	5
ナハセムスA WASHER HEAD SCREW		M2.6X10 C2700W MBN12 000-163-477-10	2
コネクタ (231) CONNECTOR		231-607/019-FUR 000-147-414-11	1
コネクタ (231) CONNECTOR		231-107/026-FUR 000-147-413-11	1

(略図の寸法は、参考値です。DIMENSIONS IN DRAWING FOR REFERENCE ONLY.)

型式/コード番号が2段の場合、下段より上段に代わる過渡期品であり、どちらかが入っています。なお、品質は変わりません。

TWO TYPES AND CODES MAY BE LISTED FOR AN ITEM. THE LOWER PRODUCT MAY BE SHIPPED IN PLACE OF THE UPPER PRODUCT. QUALITY IS THE SAME.  
03GL-X-9852

A-19







CODE NO.	008-539-540-00		0360-X-9503-6	1/1	
	TYPE	FP03-10202			
<b>付属品表 ACCESSORIES</b>					
番号 NO.	名称 NAME	略図 OUTLINE	型名/規格 DESCRIPTIONS	数量 Q'TY	用途/備考 REMARKS
1	コネクタ取付材 MOUNTING BRACKET		19-023-3091-0 ROHS CODE NO. 100-316-260-10	1	
2	ゴムパッキン GROMMET		C-30-NG-79-Q-EP-UL CODE NO. 000-173-345-10	1	
3	ハネ洗剤 SPRING WASHER		M4 SUS304 CODE NO. 000-167-405-10	4	
4	フラットワッシャー FLAT WASHER		M4 SUS304 CODE NO. 000-167-455-10	4	
5	六角ナット HEX NUT		M4 SUS304 CODE NO. 000-167-468-10	4	
6	ナハセムス WASHER HEAD SCREW		M4X10 C2700W MBN12 CODE NO. 000-163-167-10	4	

型式/コード番号が2段の場合、下段より上段に代わる過渡期品であり、どちらかが入っています。なお、品質は変わりません。  
TWO TYPES AND CODES MAY BE LISTED FOR AN ITEM. THE LOWER PRODUCT MAY BE SHIPPED IN PLACE OF THE UPPER PRODUCT. QUALITY IS THE SAME.  
(略図の寸法は、参考値です。DIMENSIONS IN DRAWING FOR REFERENCE ONLY.)

# PACKING LIST

03GL-X-9860 -6 1/1  
A-21

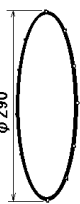
PM-31

NAME	OUTLINE	DESCRIPTION/CODE No.	QTY
<b>ユニット</b>			
スキャナカバー組品 SCANNER COVER ASSEMBLY		OP03-189-1 008-539-430-00 OP03-189-2	1
<b>工事材料</b>			
シユッカガリス GREASE		ワシワシワ #2 50G/リ 000-173-273-10	1
<b>工事材料</b>			
SM-XHコネクタ SM-XH CONNECTOR		03-2108 (P6-6P) 008-534-840-00	1
吊り金具 LIFTING FIXTURE		03-001-3264-0 ROHS 300-132-640-10	1
カバー用パッキン PACKING		03-001-3263-2 300-132-632-10	1
<b>図書</b>			
PM-31取付書 OPERATOR'S MANUAL		C32-00401-* 000-149-773-1*	1

型式/コード番号が2段の場合、下段より上段に代わる過渡期品であり、どちらが入っています。なお、品質は変わりません。  
TWO TYPES AND CODES MAY BE LISTED FOR AN ITEM. THE LOWER PRODUCT MAY BE SHIPPED IN PLACE OF THE UPPER PRODUCT. QUALITY IS THE SAME.  
(略図の寸法は、参考値です。 DIMENSIONS IN DRAWING FOR REFERENCE ONLY.)

03GL-X-9860

# FURUNO

A-22

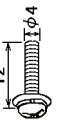
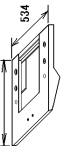
番号 NO.	名称 NAME	略図 OUTLINE	型名/規格 DESCRIPTIONS		数量 QTY	用途/備考 REMARKS
			CODE NO.	000-163-192-10		
1	ワッシャーヘッドネジ組品 WASHER HEAD SCREW *B*		IMAX12 C2700N MBW12		4	
2	連結台(20)組品 COUPLING PLATE ASSY.		OP03-183-1		1	

型式/コード番号が2段の場合、下段より上段に代わる過渡期品であり、どちらが入っています。なお、品質は変わりません。  
TWO TYPES AND CODES MAY BE LISTED FOR AN ITEM. THE LOWER PRODUCT MAY BE SHIPPED IN PLACE OF THE UPPER PRODUCT. QUALITY IS THE SAME.  
(略図の寸法は、参考値です。 DIMENSIONS IN DRAWING FOR REFERENCE ONLY.)

FURUNO ELECTRIC CO., LTD.

03GL-X-9408

# PACKING LIST

NAME OUTLINE DESCRIPTION/CODE No. Q'TY

## 工事材料表

### INSTALLATION MATERIALS

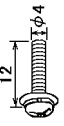
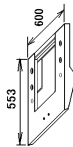
番号 NO.	名称 NAME	略図 OUTLINE	型名/規格 DESCRIPTIONS	数量 Q'TY	用途/備考 REMARKS
1	ワッシャーヘッドネジ *B*		MAX12 C2700W MBN12 CODE NO. 000-163-192-10	4	
2	連結台 (23) 組品		OP03-184-1 CODE NO. 008-536-990-00	1	

A-23









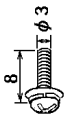
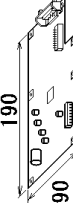
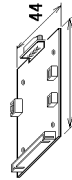

CODE NO.	008-535-650-00	03GL-X-9409 -6	1/1
TYPE	OP03-184		

型式/コード番号が2段の場合、下段より上段に代わる過渡部品であり、どちらかが入っています。なお、品質は変わりません。  
TWO TYPES AND CODES MAY BE LISTED FOR AN ITEM. THE LOWER PRODUCT MAY BE SHIPPED IN PLACE OF THE UPPER PRODUCT. QUALITY IS THE SAME.  
(略図の寸法は、参考値です。)

FURUNO ELECTRIC CO., LTD.

03GL-X-9409

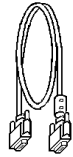
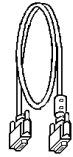
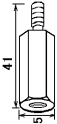
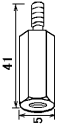
## その他部品 OTHER PARTS

名称	略図	型名/規格	数量	用途/備考
ワッシャーヘッドネジ		MAX8 C2700W MBN12	10	
DVI-RGB組品		000-163-190-10	1	
DVI-RGB ASSY.		SLB-FRM4-A 008-537-660-00	1	
RGB-BUFF7'ソケット		03P922.9B(LF)	1	
RGB-BUFF BOARD		008-554-940-00	1	
VHコネクタ		03-2092 (6P)	1	
VH CONNECTOR		008-534-690-00	1	
XHコネクタ		03-2093 (3P)	1	
XH CONNECTOR		008-534-700-00	1	
XHコネクタ		03-2094 (13-10P)	1	
XH CONNECTOR		008-534-710-00	1	
ケーブル組品		DVI-D/D S-LINK 0.85M	1	
CABLE ASSY.		000-148-644-00	1	
スペーサー		SQ-35	6	
SPACER		000-159-310-10	6	
バネワッシャー		M3 C5191W MBN12	6	
SPRING WASHER		M3 C5191W MBN12 000-168-187-10 000-864-204-00	6	

型式/コード番号が2段の場合、下段より上段に代わる過渡部品であり、どちらかが入っています。なお、品質は変わりません。  
TWO TYPES AND CODES MAY BE LISTED FOR AN ITEM. THE LOWER PRODUCT MAY BE SHIPPED IN PLACE OF THE UPPER PRODUCT. QUALITY IS THE SAME.  
(略図の寸法は、参考値です。)

FURUNO ELECTRIC CO., LTD.

03GL-X-9861



**工事材料表**

INSTALLATION MATERIALS

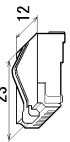
番号 NO.	名称 NAME	略図 OUTLINE	型名/規格 DESCRIPTIONS	数量 QTY	用途/備考 REMARKS
1	モジュラコネクタ MODULAR CONNECTOR	23 	MPS88-C CODE NO. 000-166-044F-10	2	

CODE NO.	008-542-460-00	036L-X-9407-4	1/1
TYPE	CP03-28901		

SHIP NO.		SPARE PARTS LIST FOR		U S E		SETS PER VESSEL	
ITEM NO.	NAME OF PART	OUTLINE	DWG. NO. OR TYPE NO.	QUANTITY		REMARKS/CODE NO.	
				WORKING	SPARE		
				PER SET	PER VES		
1	カーボンブラシ CARBON BRUSH		M6120-5X6X11 D86		2		000-631-716-00

CODE NO.	008-485-360-00	03FS-X-9301-4	1/1
TYPE	SP03-12501	BOX NO. P	

For display unit (MU-201CR/231CR, AC set)

SHIP NO.		SPARE PARTS LIST FOR		U S E		SETS PER VESSEL	
ITEM NO.	NAME OF PART	OUTLINE	DWG. NO. OR TYPE NO.	QUANTITY		REMARKS/CODE NO.	
				WORKING	SPARE		
				PER SET	PER VES		
1	ヒューズ FUSE		F6MB 250V 2A PBF F6MB 2A 250V		2		表示部用 FOR DISPLAY UNIT 000-157-497-10 000-122-000-00

CODE NO.	008-535-990	036L-X-9303-1	1/1
TYPE	SP03-14401	BOX NO. P	

For display unit (MU-201CR, DC set)

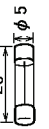
SHIP NO.		SPARE PARTS LIST FOR		U S E		SETS PER VESSEL	
ITEM NO.	NAME OF PART	OUTLINE	DWG. NO. OR TYPE NO.	QUANTITY		REMARKS/CODE NO.	
				WORKING	SPARE		
				PER SET	PER VES		
1	ヒューズ FUSE		F6MB 125V 5A PBF F6MB 5A AC125V		2		表示部用 FOR DISPLAY UNIT 000-157-491-10 000-112-785-00

CODE NO.	000-081-063-00	036L-X-9304-1	1/1
TYPE	SP03-03900	BOX NO. P	

型式/コード番号が2段の場合、下段より上段に代わる過渡製品であり、どちらかが入っています。なお、品質は変わりません。  
TWO TYPES AND CODES MAY BE LISTED FOR AN ITEM. THE LOWER PRODUCT MAY BE SHIPPED IN PLACE OF THE UPPER PRODUCT. QUALITY IS THE SAME.  
(略図の寸法は、参考値です。 DIMENSIONS IN DRAWING FOR REFERENCE ONLY.)

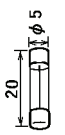
SHIP NO.		SPARE PARTS LIST FOR		CODE NO.		03GL-X-9301 -1 1/1	
				TYPE	U S E	SP03-14402	BOX NO. P
ITEM NO.	NAME OF PART	DNG. NO. OR TYPE NO.	OUTLINE	QUANTITY		REMARKS/CODE NO.	
				WORKING PER SET	SPARE PER VES		
1	E <sub>1</sub> -X <sup>*</sup> FUSE	F880 125V 6A PBF			2	表示部用 FOR DISPLAY UNIT	000-157-492-10

## For processor unit (100 VAC set)

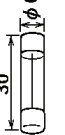
SHIP NO.		SPARE PARTS LIST FOR		CODE NO.		03GL-X-9305 -1 1/1	
				TYPE	U S E	SP03-14404	BOX NO. P
ITEM NO.	NAME OF PART	DNG. NO. OR TYPE NO.	OUTLINE	QUANTITY		REMARKS/CODE NO.	
				WORKING PER SET	SPARE PER VES		
1	E <sub>1</sub> -X <sup>*</sup> FUSE	F680 125V 10A PBF			4	ACT00用 FOR PROCESSOR UNIT	000-155-826-10

## For processor unit (220 VAC set)

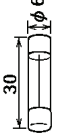
SHIP NO.		SPARE PARTS LIST FOR		CODE NO.		03GL-X-9306 -1 1/1	
				TYPE	U S E	SP03-14405	BOX NO. P
ITEM NO.	NAME OF PART	DNG. NO. OR TYPE NO.	OUTLINE	QUANTITY		REMARKS/CODE NO.	
				WORKING PER SET	SPARE PER VES		
1	E <sub>1</sub> -X <sup>*</sup> FUSE	F680 250V 5A PBF			4	AC220用 FOR PROCESSOR UNIT	000-155-840-10

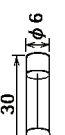
SHIP NO.		SPARE PARTS LIST FOR		CODE NO.		03GL-X-9307 -1 1/1	
				TYPE	U S E	SP03-14406	BOX NO. P
ITEM NO.	NAME OF PART	DNG. NO. OR TYPE NO.	OUTLINE	QUANTITY		REMARKS/CODE NO.	
				WORKING PER SET	SPARE PER VES		
1	カマ/カ-X <sup>*</sup> FUSE	F880 125V 20A F880 20A AC125V			4	D024用 制御部用 FOR PROCESSOR UNIT	000-155-780-10 000-549-015-00



## For GC-10

SHIP NO.		SPARE PARTS LIST FOR		CODE NO.		03GL-X-9302 -2 1/1	
				TYPE	U S E	SP03-13300	BOX NO. P
ITEM NO.	NAME OF PART	DNG. NO. OR TYPE NO.	OUTLINE	QUANTITY		REMARKS/CODE NO.	
				WORKING PER SET	SPARE PER VES		
1	E <sub>1</sub> -X <sup>*</sup> FUSE	F680 250V 2A PBF F680 2A 250V			8		000-157-497-10 000-122-000-00

CODE NO.	008-535-560-00	036L-X-9501 -5
TYPE	FP03-09820	1/1

付属品表

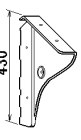
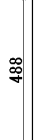
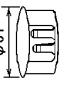
ACCESSORIES

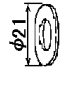
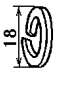
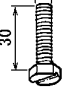
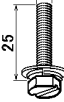

番号 NO.	名称 NAME	略図 OUTLINE	型名/規格 DESCRIPTIONS	数量 Q'TY	用途/備考 REMARKS
1	ハガー-L(20) HANGER L		03-163-1111-1 ROHS 03-163-1111-1 CODE NO. 100-305-141-10 100-305-141-00	1	
2	ハガー-R(20) HANGER R		03-163-1112-1 ROHS 03-163-1112-1 CODE NO. 100-305-181-10 100-305-181-00	1	
3	ハガー-押柱(20) HANGER STAY		03-163-1113-1 ROHS CODE NO. 100-305-191-10	1	
4	ホーフラグ HOLE PLUG		CP-30-HP-13 CODE NO. 000-160-074-10	2	
5	スナップボタン SNAP BUTTON		KB-133P ホック用 CODE NO. 000-570-276-10	4	
6	フラットワッシャー FLAT WASHER		M10 SUS304 CODE NO. 000-167-232-10	2	
7	スプリングワッシャー SPRING WASHER		M10 SUS304 CODE NO. 000-167-233-10	2	
8	六角ボルト HEX. BOLT		M10X30 SUS304 CODE NO. 000-162-884-10	2	
9	六角ボルト (スリットド・ワッシャーヘッド) HEX BOLT (SLOTTED WASHER HEAD)		M6X25 SUS304 CODE NO. 000-162-949-10	4	

型式/コード番号が2段の場合、下段より上段に代わる通称部品であり、どちらが入っています。なお、品質は変わりません。  
 TWO TYPES AND CODES MAY BE LISTED FOR AN ITEM. THE LOWER PRODUCT MAY BE SHIPPED IN PLACE OF THE UPPER PRODUCT.  
 QUALITY IS THE SAME.  
 (略図の寸法は、参考値です。 DIMENSIONS IN DRAWING FOR REFERENCE ONLY.)

CODE NO.	008-535-020-00	036M-X-9501 -5
TYPE	FP03-09830	1/1

付属品表

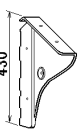
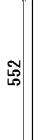
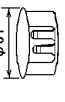
ACCESSORIES

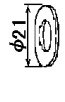
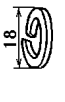
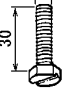
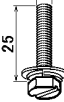
番号 NO.	名称 NAME	略図 OUTLINE	型名/規格 DESCRIPTIONS	数量 Q'TY	用途/備考 REMARKS
1	ハガー-L(20) HANGER L		03-163-1111-1 ROHS 03-163-1111-1 CODE NO. 100-305-141-10 100-305-141-00	1	
2	ハガー-R(20) HANGER R		03-163-1112-1 ROHS 03-163-1112-1 CODE NO. 100-305-181-10 100-305-181-00	1	
3	ハガー-押柱(20) HANGER STAY		03-163-2071-1 ROHS CODE NO. 100-305-371-10	1	
4	ホーフラグ HOLE PLUG		CP-30-HP-13 CODE NO. 000-160-074-10	2	
5	スナップボタン SNAP BUTTON		KB-133P ホック用 CODE NO. 000-570-276-10	4	
6	フラットワッシャー FLAT WASHER		M10 SUS304 CODE NO. 000-167-232-10	2	
7	スプリングワッシャー SPRING WASHER		M10 SUS304 CODE NO. 000-167-233-10	2	
8	六角ボルト HEX. BOLT		M10X30 SUS304 CODE NO. 000-162-884-10	2	
9	六角ボルト (スリットド・ワッシャーヘッド) HEX BOLT (SLOTTED WASHER HEAD)		M6X25 SUS304 CODE NO. 000-162-949-10	4	

型式/コード番号が2段の場合、下段より上段に代わる通称部品であり、どちらが入っています。なお、品質は変わりません。  
 TWO TYPES AND CODES MAY BE LISTED FOR AN ITEM. THE LOWER PRODUCT MAY BE SHIPPED IN PLACE OF THE UPPER PRODUCT.  
 QUALITY IS THE SAME.  
 (略図の寸法は、参考値です。 DIMENSIONS IN DRAWING FOR REFERENCE ONLY.)

This page intentionally left blank.

表 1 TABLE 1

寸法区分 (mm) DIMENSIONS	公差 (mm) TOLERANCE
L ≤ 50	± 1.5
50 < L ≤ 100	± 2.5
100 < L ≤ 500	± 3
500 < L ≤ 1000	± 4
1000 < L ≤ 2000	± 5
2000 < L ≤ 4000	± 7

表 2 TABLE 2

アンテナ型式 ANTENNA TYPE	XN-20AF (200cm型)	XN-24AF (240cm型)
A: 空中線長 ANTENNA LENGTH (mm)	2040 ± 10	2550 ± 10
B: 回転安全空間 ANTI-CLEARANCE (mm)	2200	2700
質量 MASS (kg±10%)	39	42

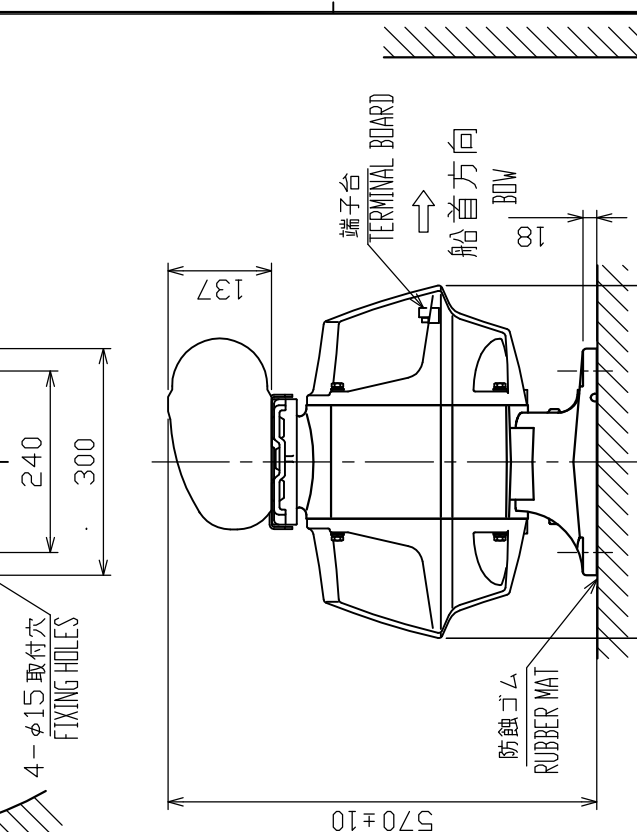
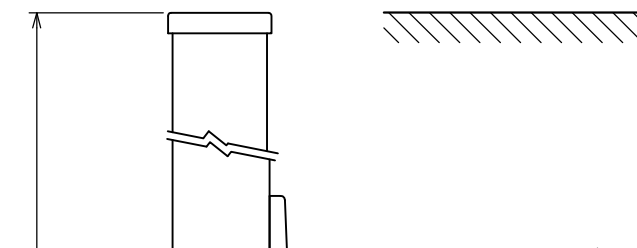
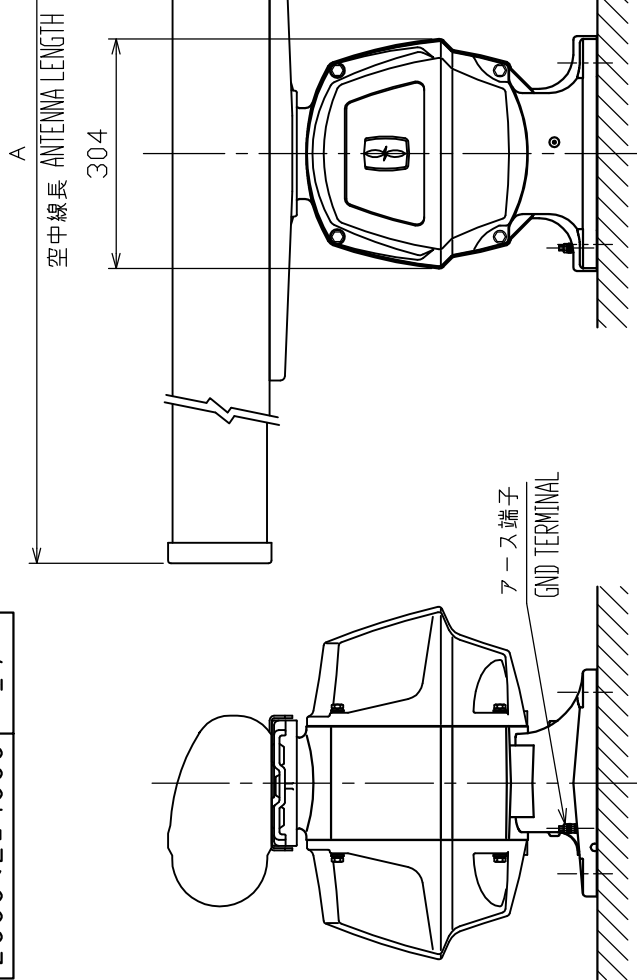

- 注 記 1) #印寸法は最小サービス空間寸法とする。  
 2) A, B寸法、及び質量は表2による。  
 3) 指定外の寸法公差は表1による。  
 4) 取付用ネジはM12ボルトを使用のこと。
- NOTE 1. # MINIMUM SERVICE CLEARANCE.  
 2. TABLE 2 INDICATES MASS AND DIMENSIONS A & B.  
 3. TABLE 1 INDICATES TOLERANCE OF DIMENSIONS WHICH IS NOT SPECIFIED.  
 4. USE M12 BOLTS FOR FIXING THE UNIT.

DRAWN	Dec. 25 '03	E. MIYOSHI	TITLE	RSB-096/097
CHECKED	Dec. 25 '03	TAKAHASHI, T.	名称	空中線部
APPROVED	Dec. 25 '03	Y. Ho-toi	外寸図	
SCALE	1/10	表名参照	NAME	ANTENNA UNIT
DWG. No.	C3519-602-B			03-154-301G-2
				OUTLINE DRAWING

表 1 TABLE 1

寸法区分 (mm) DIMENSIONS	公差 (mm) TOLERANCE
L ≤ 50	± 1.5
50 < L ≤ 100	± 2.5
100 < L ≤ 500	± 3
500 < L ≤ 1000	± 4
1000 < L ≤ 2000	± 5
2000 < L ≤ 4000	± 7

表 2 TABLE 2

アンテナ型式 ANTENNA TYPE	XN-12AF (120cm型)
A: 空中線長 ANTENNA LENGTH (mm)	1260 ± 10
B: 回転安全空間 ANT. CLEARANCE (mm)	1,400
質量 MASS (kg ± 10%)	33

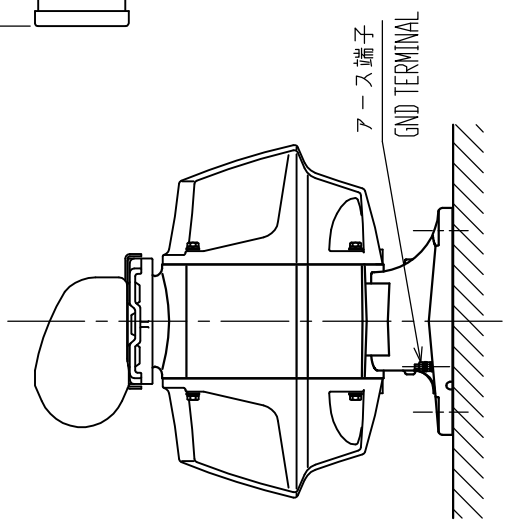
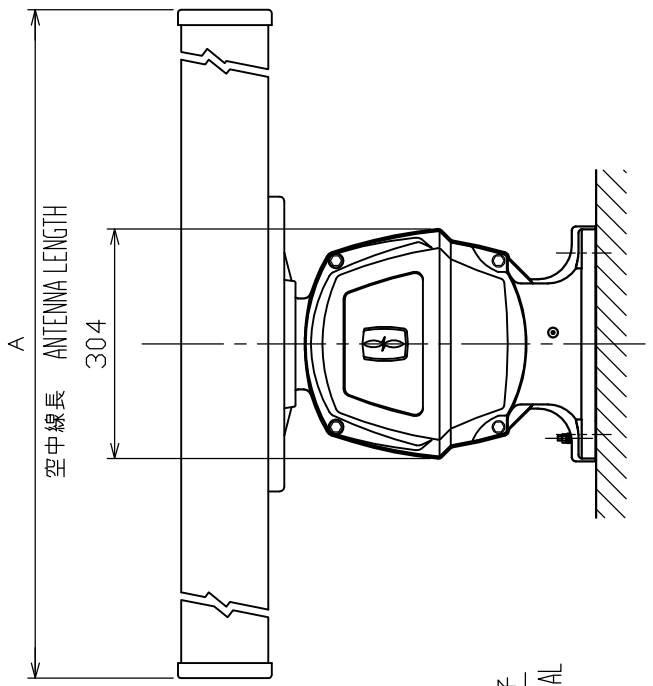
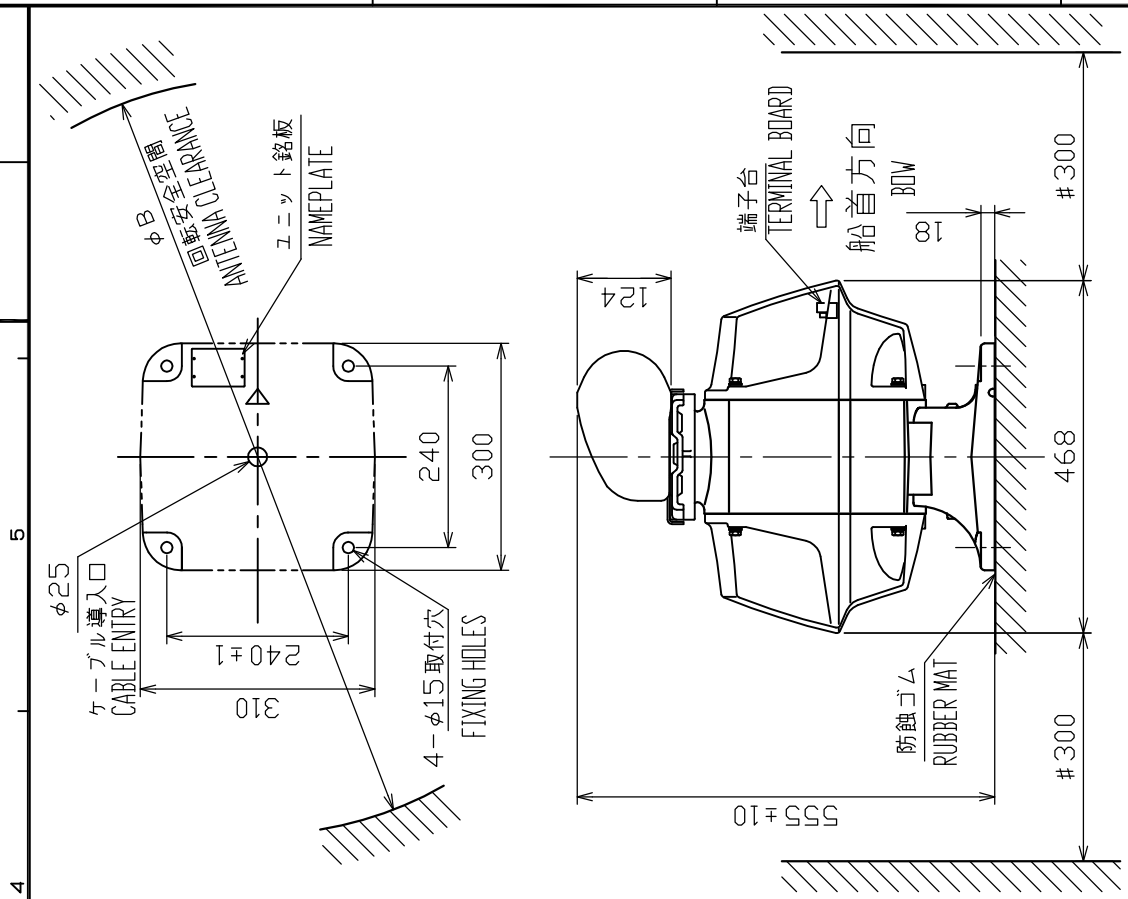

- 注記 1) #印寸法は最小サービス空間寸法とする。  
 2) A, B寸法、及び質量は表2による。  
 3) 指定外の寸法公差は表1による。  
 4) 取付用ネジはM12ボルトを使用のこと。
- NOTE 1. #: MINIMUM SERVICE CLEARANCE.  
 2. TABLE 2 INDICATES MASS AND DIMENSIONS A & B.  
 3. TABLE 1 INDICATES TOLERANCE OF DIMENSIONS WHICH IS NOT SPECIFIED.  
 4. USE M12 BOLTS FOR FIXING THE UNIT.

DRAWN	Dec. 25 '03	E. MIYOSHI	TITLE	RSB-096/097-12AF
CHECKED	Dec. 25 '03	TAKAHASHI, T	名#	空中線部
APPROVED	Dec. 25 '03	Y. Hatai	外寸図	
SCALE	1/10	MASS 33 kg	NAME	ANTENNA UNIT
FIG. No.	C3519-G08-B			03-154-306G-2
				OUTLINE DRAWING

表 1 TABLE 1

寸法区分 (mm) DIMENSION	公差 (mm) TOLERANCE
L ≤ 50	±1.5
50 < L ≤ 100	±2.5
100 < L ≤ 500	±3
500 < L ≤ 1000	±4
1000 < L ≤ 2000	±5
2000 < L ≤ 4000	±7

表 2 TABLE 2

アンテナ型式 ANTENNA TYPE	XN-20AF	XN-24AF
A : 空中線長 ANTENNA LENGTH (mm)	2,040±10	2,550±10
B : 回転安全空間 ANTENNA CLEARANCE (mm)	2,200	2,700
質量 MASS (kg±10%)	39	42

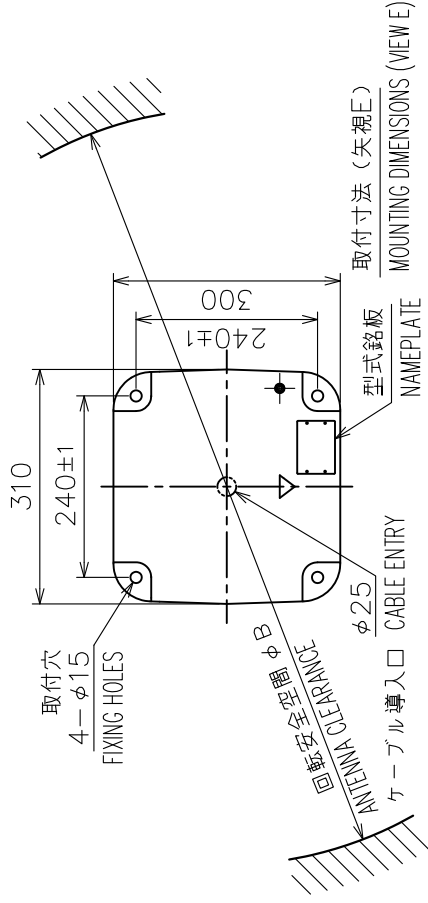

空中線長 A ANTENNA LENGTH

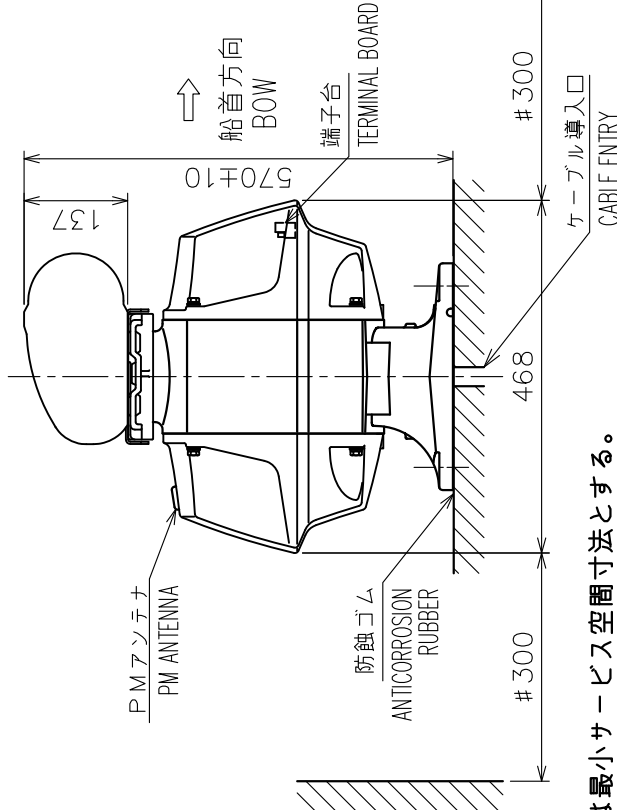

FRONT VIEW

- 注記 1) #印寸法は最小サービス空間寸法とする。  
 2) 指定外の寸法公差は表 1 による。  
 3) 取付用ネジは M12 ボルトを使用のこと。

NOTE 1. # MINIMUM SERVICE CLEARANCE.

2. TABLE 1 INDICATES TOLERANCE OF DIMENSIONS WHICH IS NOT SPECIFIED.

3. USE M12 BOLTS FOR FIXING THE UNIT.

DRAWN	Feb. 15 '08 I. YAMASAKI	TITLE	RSB-096/097 (w/PM)
CHECKED	Feb. 15 '08 I. TAKENO	名称	空中線部
APPROVED	Jun. 11 '08 R. Esumi	外寸図	
SCALE	1/10 MASS 表之参照 SEE TABLE 2	NAME	ANTENNA UNIT
DWG.No.	C3519-001-C		OUTLINE DRAWING

表 1 TABLE 1

寸法区分 (mm) DIMENSIONS	公差 (mm) TOLERANCE
L ≤ 50	± 1.5
50 < L ≤ 100	± 2.5
100 < L ≤ 500	± 3
500 < L ≤ 1000	± 4
1000 < L ≤ 2000	± 5
2000 < L ≤ 4000	± 7

表 2 TABLE 2

アンテナ型式 ANTENNA TYPE	XN-12AF (120cm型)
A: 空中線長 ANTENNA LENGTH (mm)	1260 ± 10
B: 回転安全空間 ANT. CLEARANCE (mm)	1,400
質量 MASS (kg ± 10%)	33

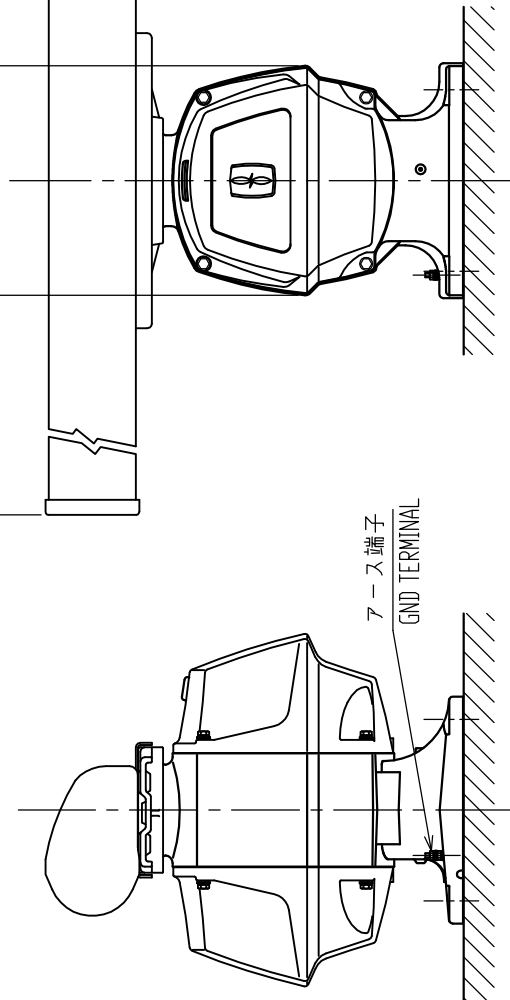
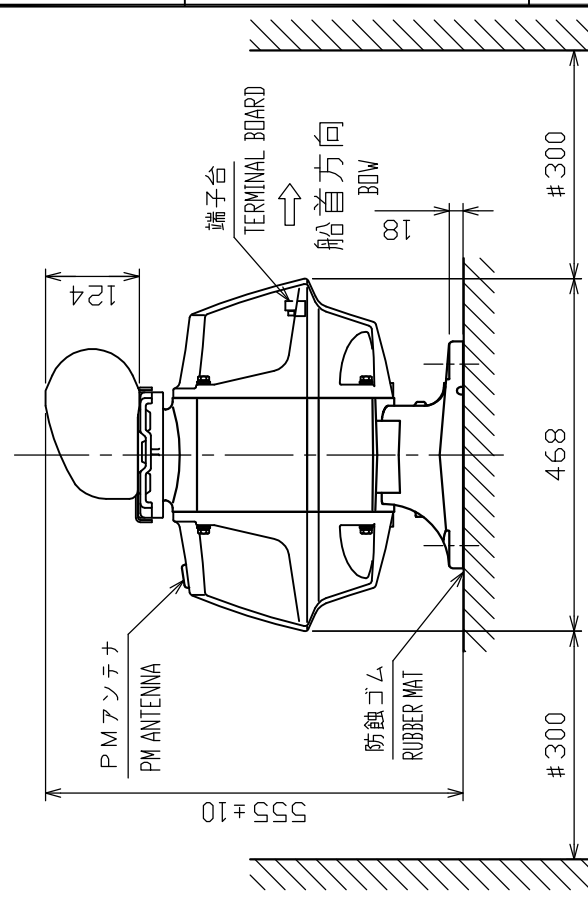
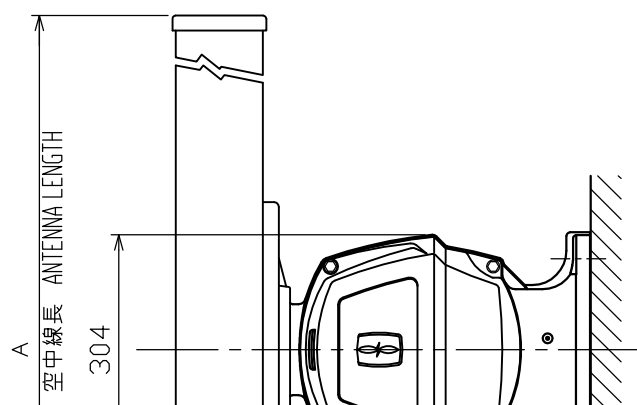
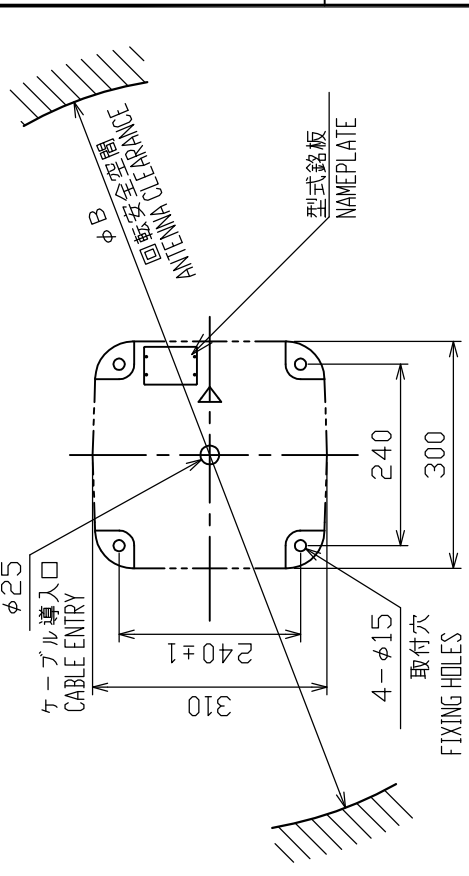

- 注 記 1) #印寸法は最小サービス空間寸法とする。  
 2) A, B寸法、及び質量は表2による。  
 3) 指定外の寸法公差は表1による。  
 4) 取付用ネジはM12ボルトを使用のこと。

- NOTE 1. # MINIMUM SERVICE CLEARANCE.  
 2. TABLE 2 INDICATES MASS AND DIMENSIONS A & B.  
 3. TABLE 1 INDICATES TOLERANCE OF DIMENSIONS WHICH IS NOT SPECIFIED.  
 4. USE M12 BOLTS FOR FIXING THE UNIT.

DRAWN	Jan. 5 '04	E. MIYOSHI	TITLE	RSB-096/097-12AF (PM-31)
CHECKED	Jan. 5 '04	TAKAHASHI, T	名称	空中線部
APPROVED	Jan. 5 '04	Y. Hatai	外寸図	
SCALE	1/10	MASS 33 kg	NAME	ANTENNA UNIT
DWG No.	C3519-G07-B			03-154-305G-2
				OUTLINE DRAWING



表 1 TABLE 1

寸法区分 (mm) DIMENSIONS	公差 (mm) TOLERANCE
L ≤ 50	± 1.5
50 < L ≤ 100	± 2.5
100 < L ≤ 500	± 3
500 < L ≤ 1000	± 4
1000 < L ≤ 2000	± 5
2000 < L ≤ 4000	± 7

表 2 TABLE 2

アンテナ型式 ANTENNA TYPE	XN-20AF (200cm型)	XN-24AF (240cm型)
A: 空中線長 ANTENNA LENGTH (mm)	2040 ± 10	2550 ± 10
B: 回転安全空間 ANT. CLEARANCE (mm)	2200	2700
質量 MASS (kg ± 10%)	39	42

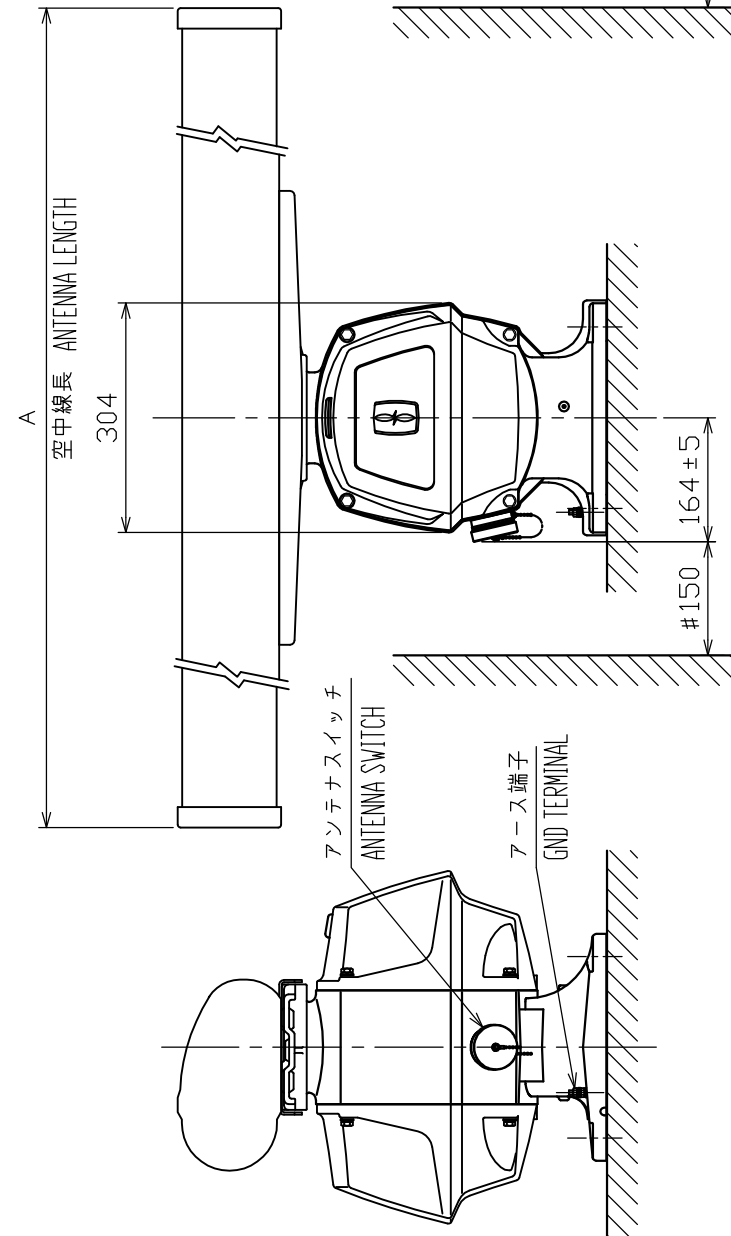
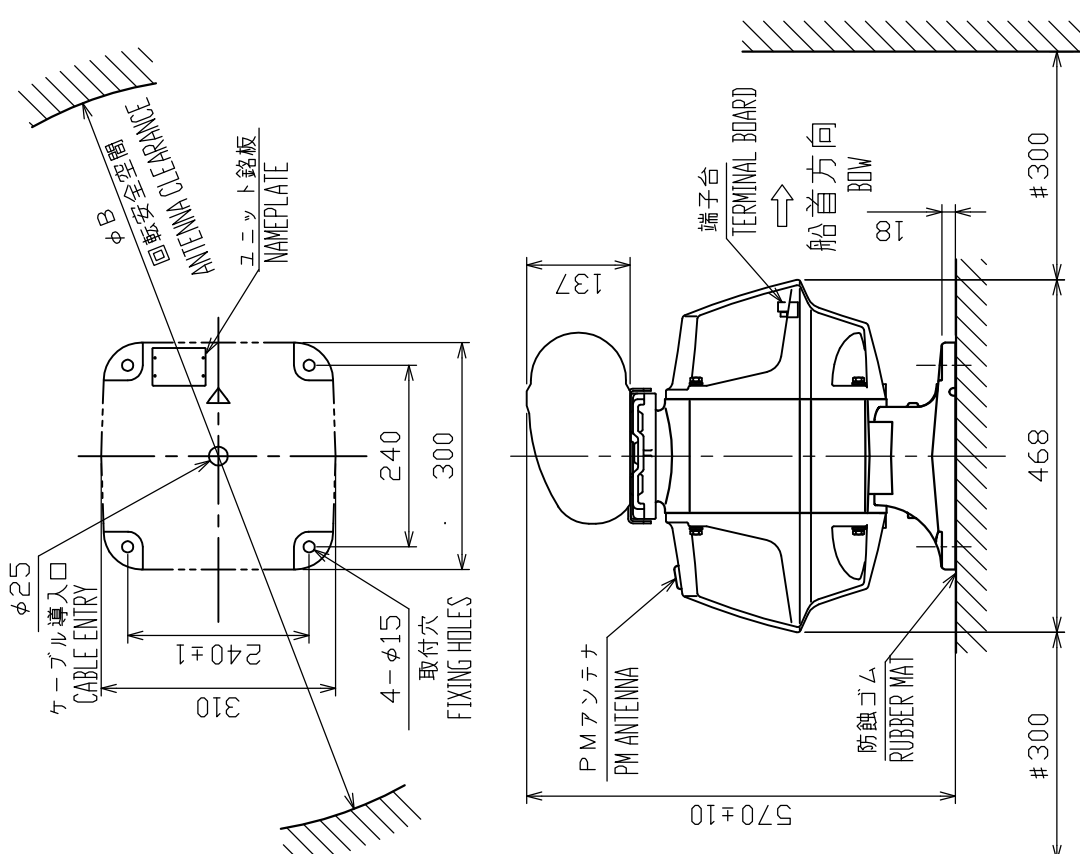

- 注 記
- 1) #印寸法は最小サービス空間寸法とする。
  - 2) A, B寸法、及び質量は表2による。
  - 3) 指定外の寸法公差は表1による。
  - 4) 取付用ネジはM12ボルトを使用のこと。
- NOTE
1. # MINIMUM SERVICE CLEARANCE.
  2. TABLE 2 INDICATES MASS AND DIMENSIONS A & B.
  3. TABLE 1 INDICATES TOLERANCE OF DIMENSIONS WHICH IS NOT SPECIFIED.
  4. USE M12 BOLTS FOR FIXING THE UNIT.

DRAWN	Jun. 5 '04	E. MIYOSHI	TITLE	RSB-096/097 (PM-31)
CHECKED	Jun. 5 '04	TAKAHASHI, T	名称	空中線部
APPROVED	Jun. 5 '04	Y. Ho.toi	外寸図	
SCALE	1/10	表名参照	NAME	ANTENNA UNIT
DATE No.	C3519-G19-A			03-154-302G-0
				OUTLINE DRAWING

表 1 TABLE 1

寸法区分 (mm) DIMENSIONS	公差 (mm) TOLERANCE
L ≤ 50	± 1.5
50 < L ≤ 100	± 2.5
100 < L ≤ 500	± 3
500 < L ≤ 1000	± 4
1000 < L ≤ 2000	± 5
2000 < L ≤ 4000	± 7

表 2 TABLE 2

アンテナ型式 ANTENNA TYPE	XN-20AF (200cm型)	XN-24AF (240cm型)
A: 空中線長 ANTENNA LENGTH (mm)	2040 ± 10	2550 ± 10
B: 回転安全空間 ANT. CLEARANCE (mm)	2200	2700
質量 MASS (kg ± 10%)	39	42

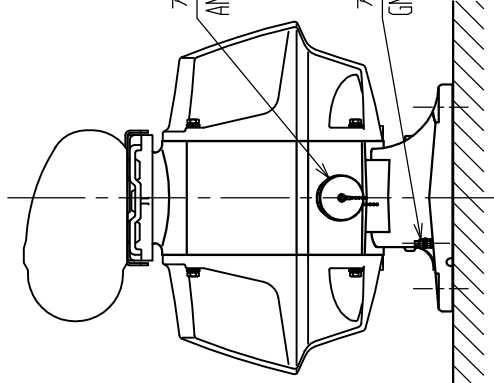
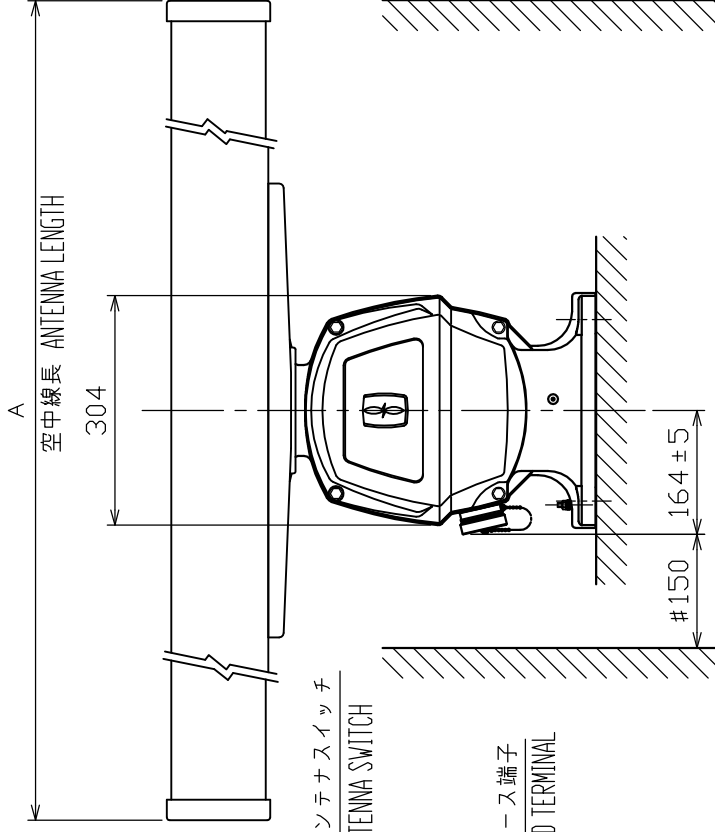
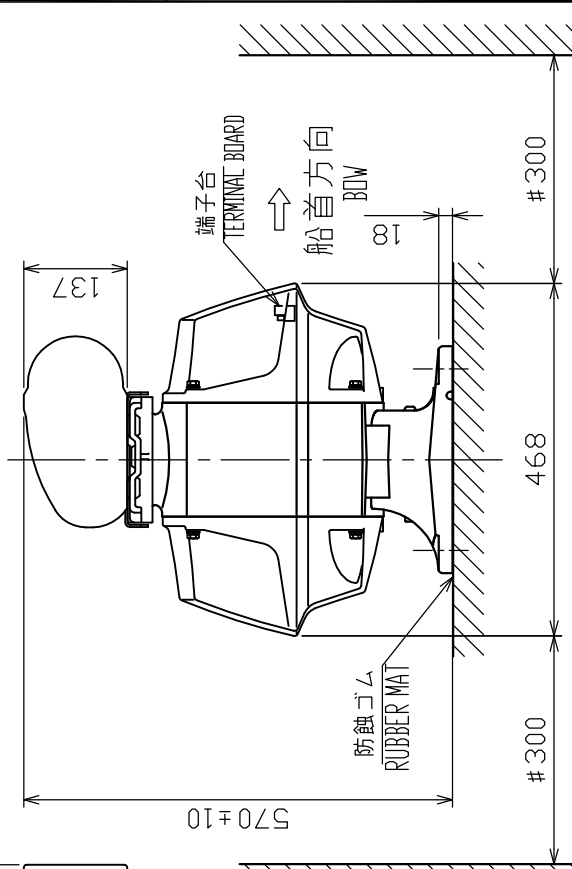
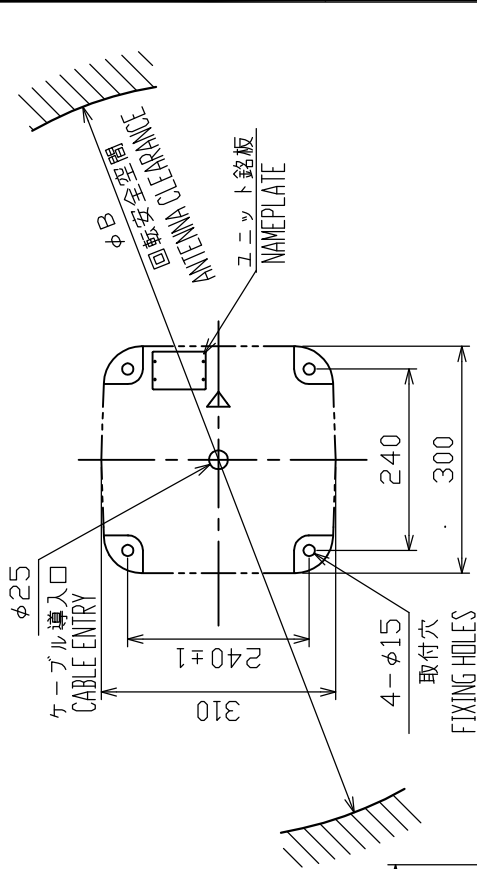

- 注 記
- 1) #印寸法は最小サービス空間寸法とする。
  - 2) A, B寸法、及び質量は表2による。
  - 3) 指定外の寸法公差は表1による。
  - 4) 取付用ネジはM12ボルトを使用のこと。
- NOTE
1. # MINIMUM SERVICE CLEARANCE.
  2. TABLE 2 INDICATES MASS AND DIMENSIONS A & B.
  3. TABLE 1 INDICATES TOLERANCE OF DIMENSIONS WHICH IS NOT SPECIFIED.
  4. USE M12 BOLTS FOR FIXING THE UNIT.

DRAWN	Jan. 5 '04	E. MIYOSHI	TITLE	RSB-096/097
CHECKED	Jan. 5 '04	TAKAHASHI, T	名称	空中線部
APPROVED	Jan. 5 '04	Y. Hojoi	外寸図	
SCALE	1/10	表2参照	NAME	ANTENNA UNIT
DWG. No.	C3519-G20-A			OUTLINE DRAWING



表 1 TABLE 1

寸法区分 (mm) DIMENSIONS	公差 (mm) TOLERANCE
L ≤ 50	± 1.5
50 < L ≤ 100	± 2.5
100 < L ≤ 500	± 3
500 < L ≤ 1000	± 4
1000 < L ≤ 2000	± 5
2000 < L ≤ 4000	± 7

表 2 TABLE 2

アンテナ型式 ANTENNA TYPE	XN-12AF (120cm型)
A: 空中線長 ANTENNA LENGTH (mm)	1260 ± 10
B: 回転安全空間 ANT. CLEARANCE (mm)	1400

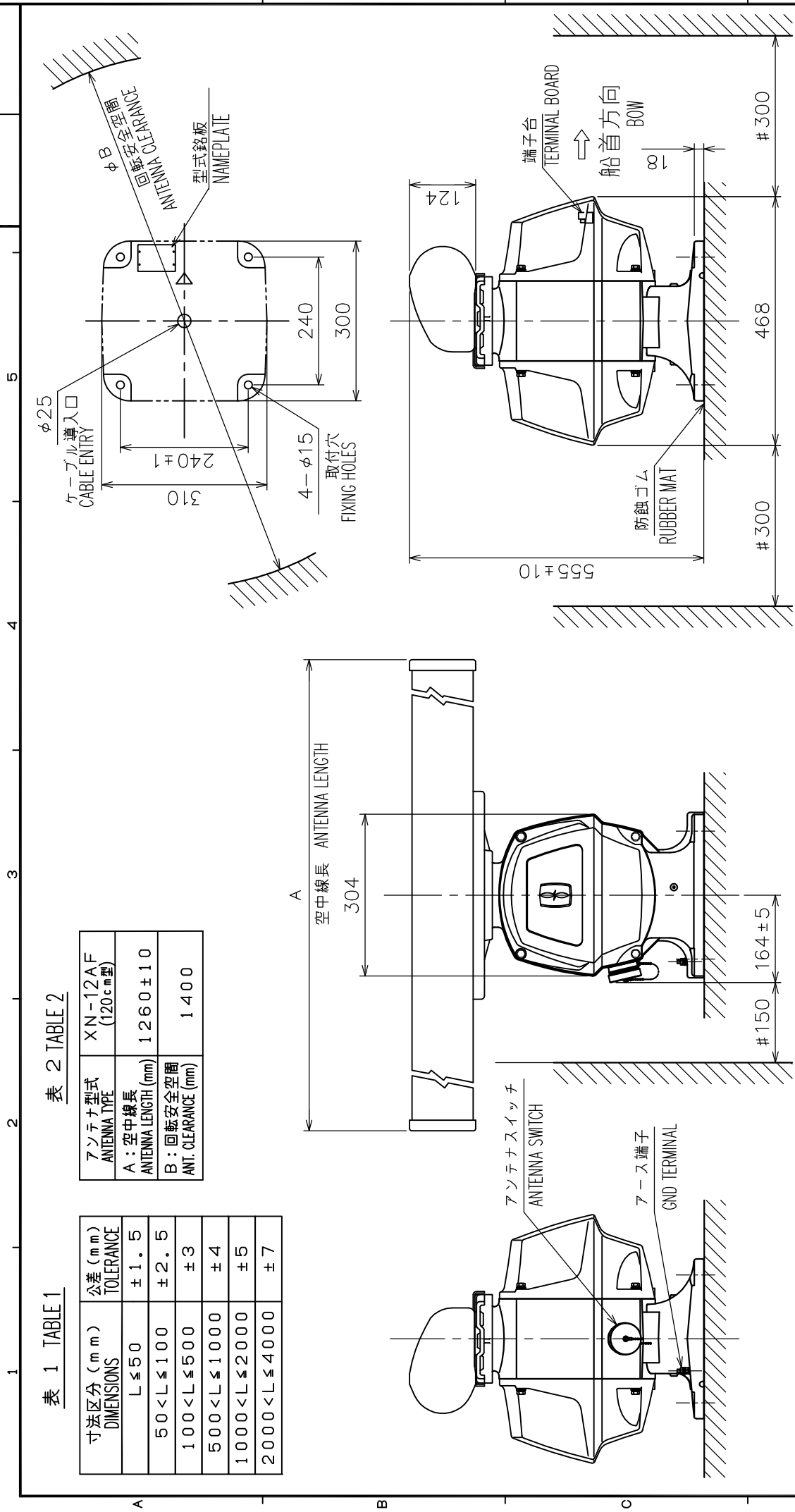

注 記 1) #印寸法は最小サービスインスペーシングとする。  
 2) 指定外の寸法公差は表1による。  
 3) 取付用ネジはM12ボルトを使用のこと。  
 4) A, B寸法は表2による。

NOTE 1. # MINIMUM SERVICE CLEARANCE.  
 2. TABLE 1 INDICATES TOLERANCE OF DIMENSIONS WHICH IS NOT SPECIFIED.  
 3. USE M12 BOLTS FOR FIXING THE UNIT.  
 4. TABLE 2 INDICATES DIMENSIONS A & B.

DRAWN	Jun. 27, '06	E. MIYOSHI	TITLE	RSB-096/097-12AF
CHECKED		TAKAHASHI, T	名称	空中線部
APPROVED		Y. Hatoi	外寸図	
SCALE	1/10	MAX ±10%	NAME	ANTENNA UNIT
DWG No.	C3519-G22-B	03-154-308G-0	OUTLINE DRAWING	

表 1 TABLE 1

寸法区分 (mm) DIMENSIONS	公差 (mm) TOLERANCE
L ≤ 50	± 1.5
50 < L ≤ 100	± 2.5
100 < L ≤ 500	± 3
500 < L ≤ 1000	± 4
1000 < L ≤ 2000	± 5
2000 < L ≤ 4000	± 7

表 2 TABLE 2

アンテナ型式 ANTENNA TYPE	XN-20AF (200cm型)	XN-24AF (240cm型)
A: 空中線長 ANTENNA LENGTH (mm)	2040±10	2550±10
B: 回転安全空間 ANT. CLEARANCE (mm)	2200	2700
質量 MASS (kg±10%)	39	42

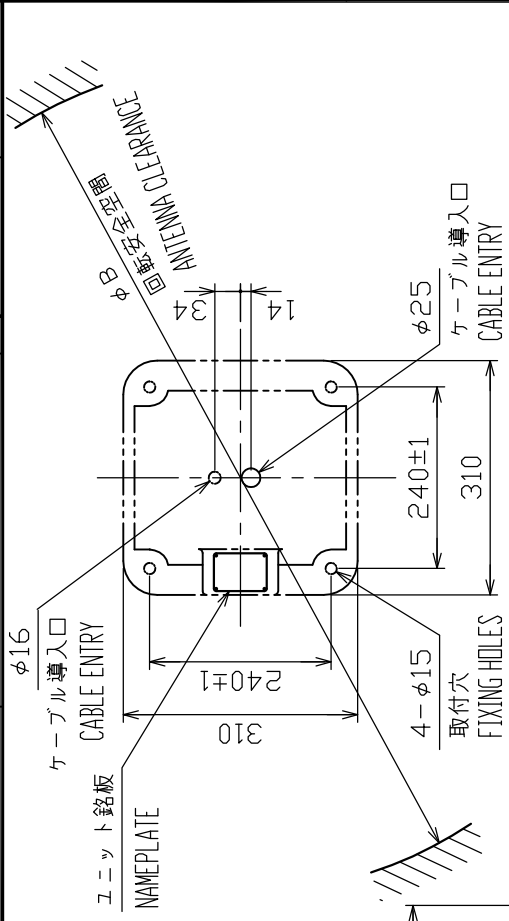
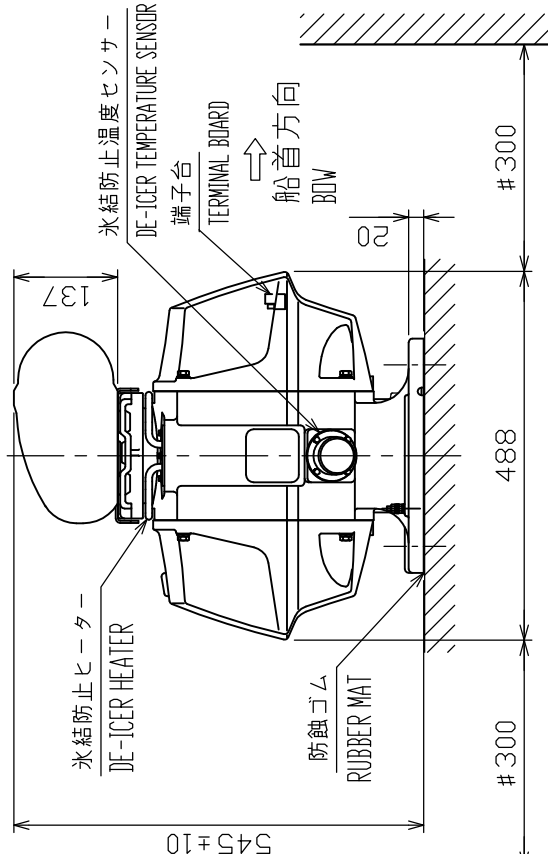
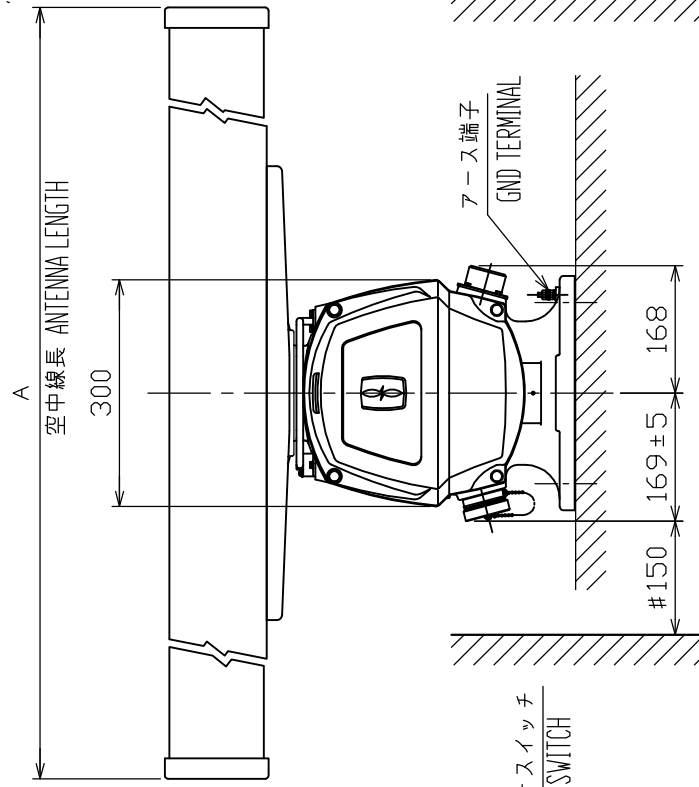
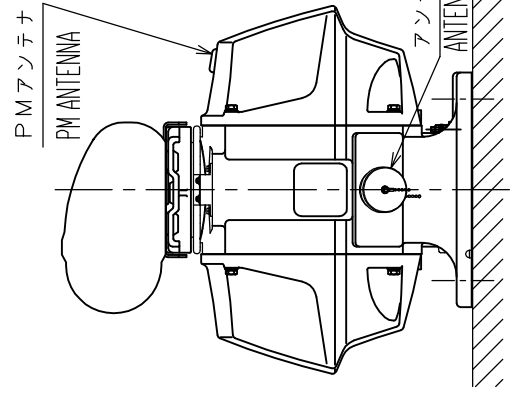

注 記 1) #印寸法は最小サービス空間寸法とする。  
 2) A, B寸法、及び質量は表2による。  
 3) 指定外の寸法公差は表1による。  
 4) 取付用ネジはM12ボルトを使用のこと。

NOTE 1. #: MINIMUM SERVICE CLEARANCE.  
 2. TABLE 2 INDICATES MASS AND DIMENSIONS A & B.  
 3. TABLE 1 INDICATES TOLERANCE OF DIMENSIONS WHICH IS NOT SPECIFIED.  
 4. USE M12 BOLTS FOR FIXING THE UNIT.

DRAWN	Jun. 5 '04	E. MIYOSHI	TITLE	RSB-096/097 (PM-31)
CHECKED		TAKAHASHI, T	名称	空中線部 (氷結防止付き)
APPROVED		Y. Ho toi	外寸図	
SCALE	1/10	表 2参照	NAME	ANTENNA UNIT (W/DE-ICER)
DWG No.	C3519-G23-A			OUTLINE DRAWING

表 1 TABLE 1

寸法区分 (mm) DIMENSIONS	公差 (mm) TOLERANCE
$L \leq 50$	$\pm 1.5$
$50 < L \leq 100$	$\pm 2.5$
$100 < L \leq 500$	$\pm 3$
$500 < L \leq 1000$	$\pm 4$
$1000 < L \leq 2000$	$\pm 5$
$2000 < L \leq 4000$	$\pm 7$

表 2 TABLE 2

アンテナ型式 ANTENNA TYPE	XN-20AF (200cm型)	XN-24AF (240cm型)
A: 空中線長 ANTENNA LENGTH (mm)	2040±10	2550±10
B: 回転安全空間 ANT. CLEARANCE (mm)	2200	2700
質量 MASS (kg±10%)	39	42

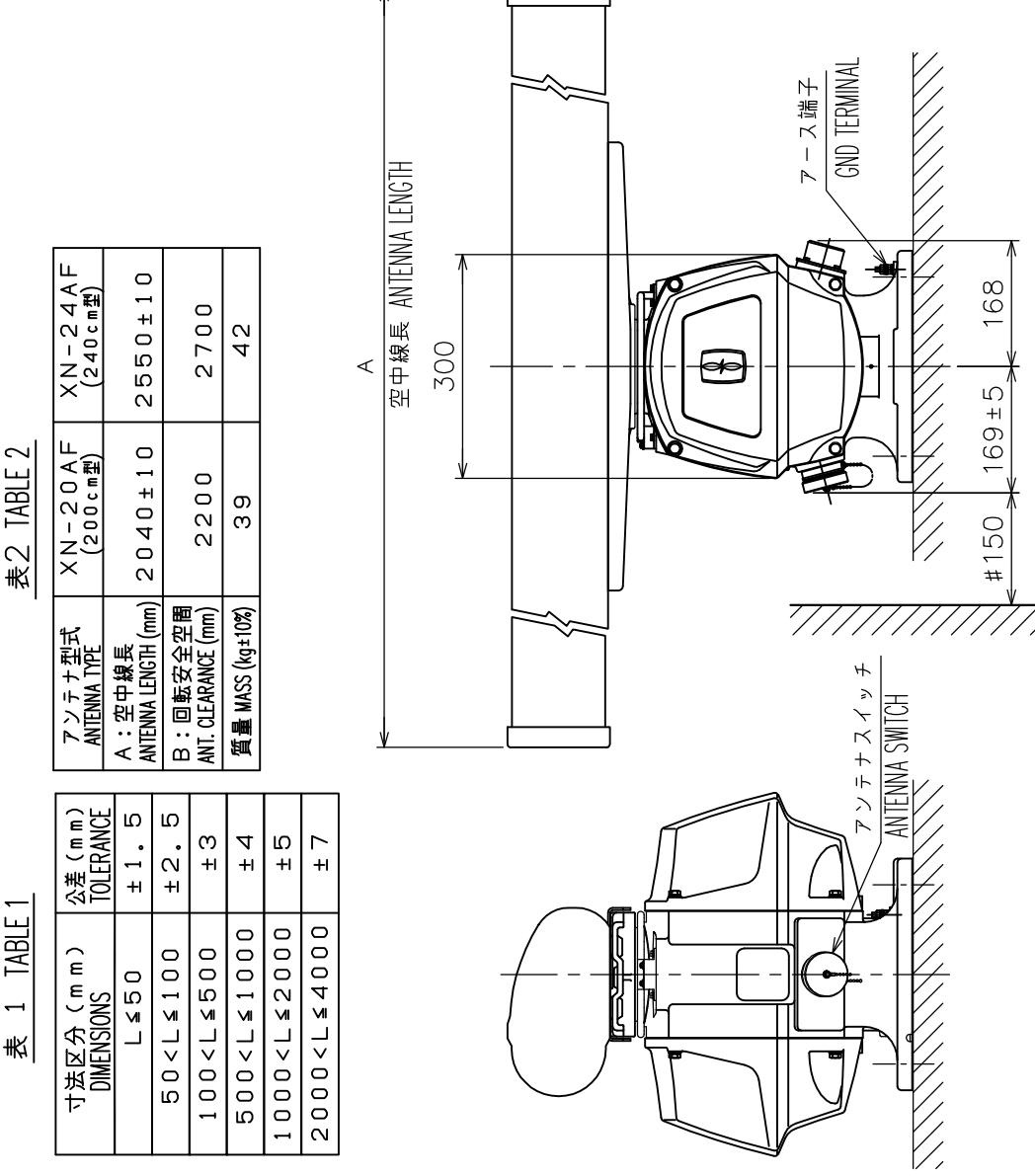
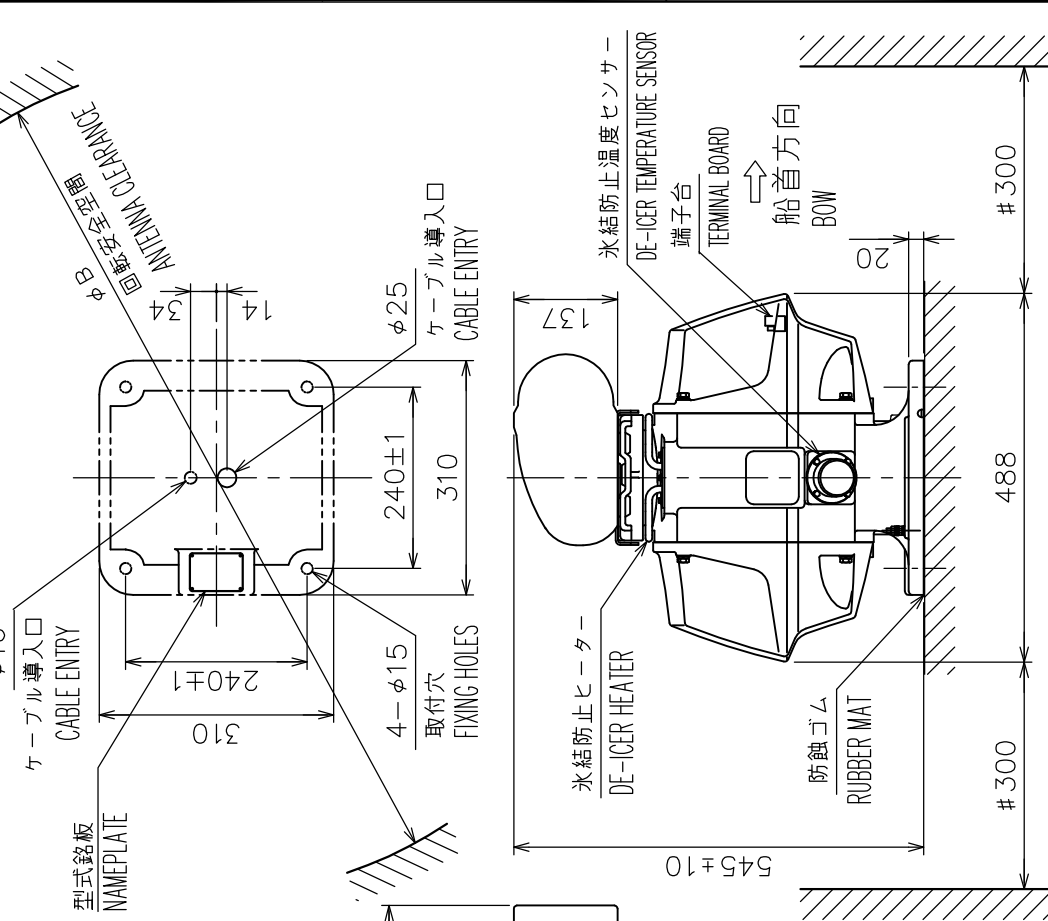

- 注記 1) #印寸法は最小サービス空間寸法とする。  
 2) 指定外の寸法公差は表1による。  
 3) 取付用ネジはM12ボルトを使用のこと。  
 4) A, B寸法は表2による。
- NOTE 1. # MINIMUM SERVICE CLEARANCE.  
 2. TABLE 1 INDICATES TOLERANCE OF DIMENSIONS WHICH IS NOT SPECIFIED.  
 3. USE M12 BOLTS FOR FIXING THE UNIT.  
 4. TABLE 2 INDICATES DIMENSIONS A & B.

DRAWN	DATE	DESIGNED	CHECKED	APPROVED	SCALE	DWG. No.	TITLE
Jun. 27, 06	E. MIYOSHI	TAKAHASHI, T	Y. Hotoi	Y. Hotoi	1/10	C3519-G24-B	RSB-096/097
							名称 空中線部 (氷結防止付き)
							外寸図
							NAME ANTENNA UNIT (W/DE-ICER)
							OUTLINE DRAWING

表 1 TABLE 1

寸法区分 (m m) DIMENSIONS	公差 (m m) TOLERANCE
L ≤ 50	± 1.5
50 < L ≤ 100	± 2.5
100 < L ≤ 500	± 3
500 < L ≤ 1000	± 4
1000 < L ≤ 2000	± 5
2000 < L ≤ 4000	± 7

表 2 TABLE 2

アンテナ型式 ANTENNA TYPE	XN-12AF (120cm型)
A: 空中線長 ANTENNA LENGTH (mm)	1260 ± 10
B: 回転安全空間 ANT. CLEARANCE (mm)	1,400
質量 MASS (kg ± 10%)	33

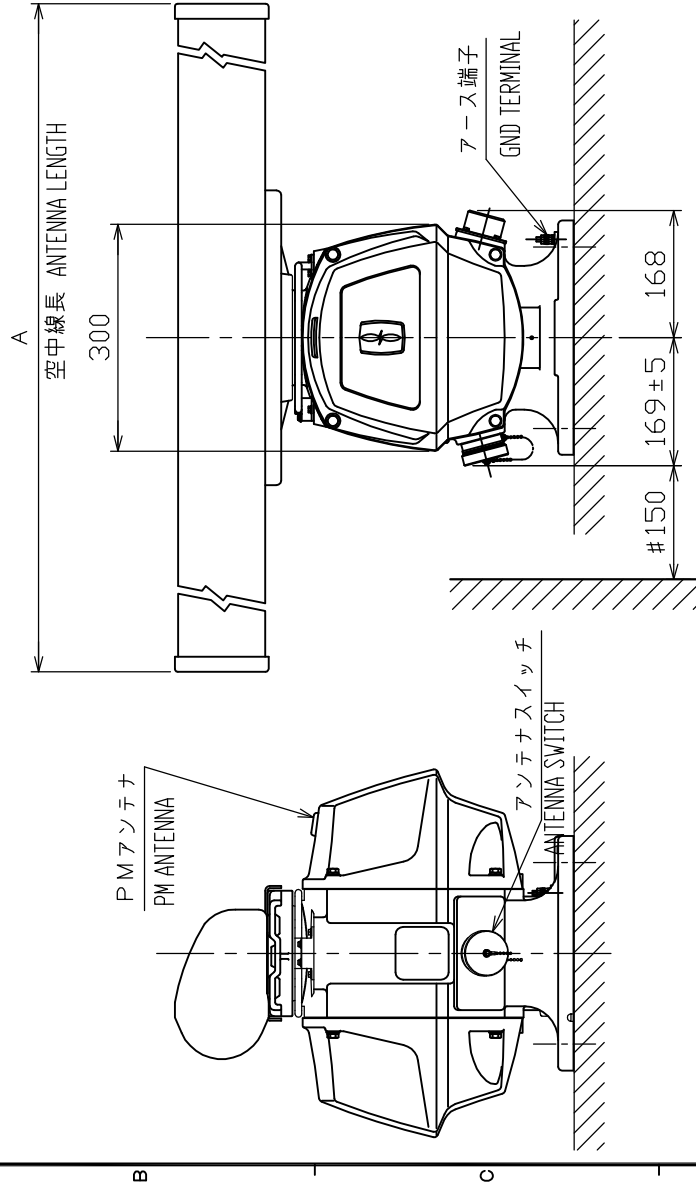

- 注 記 1) #印寸法は最小サービス空間寸法とする。  
 2) A, B寸法、及び質量は表2による。  
 3) 指定外の寸法公差は表1による。  
 4) 取付用ネジはM12ボルトを使用のこと。

- NOTE 1. # MINIMUM SERVICE CLEARANCE.  
 2. TABLE 2 INDICATES MASS AND DIMENSIONS A & B.  
 3. TABLE 1 INDICATES TOLERANCE OF DIMENSIONS WHICH IS NOT SPECIFIED.  
 4. USE M12 BOLTS FOR FIXING THE UNIT.

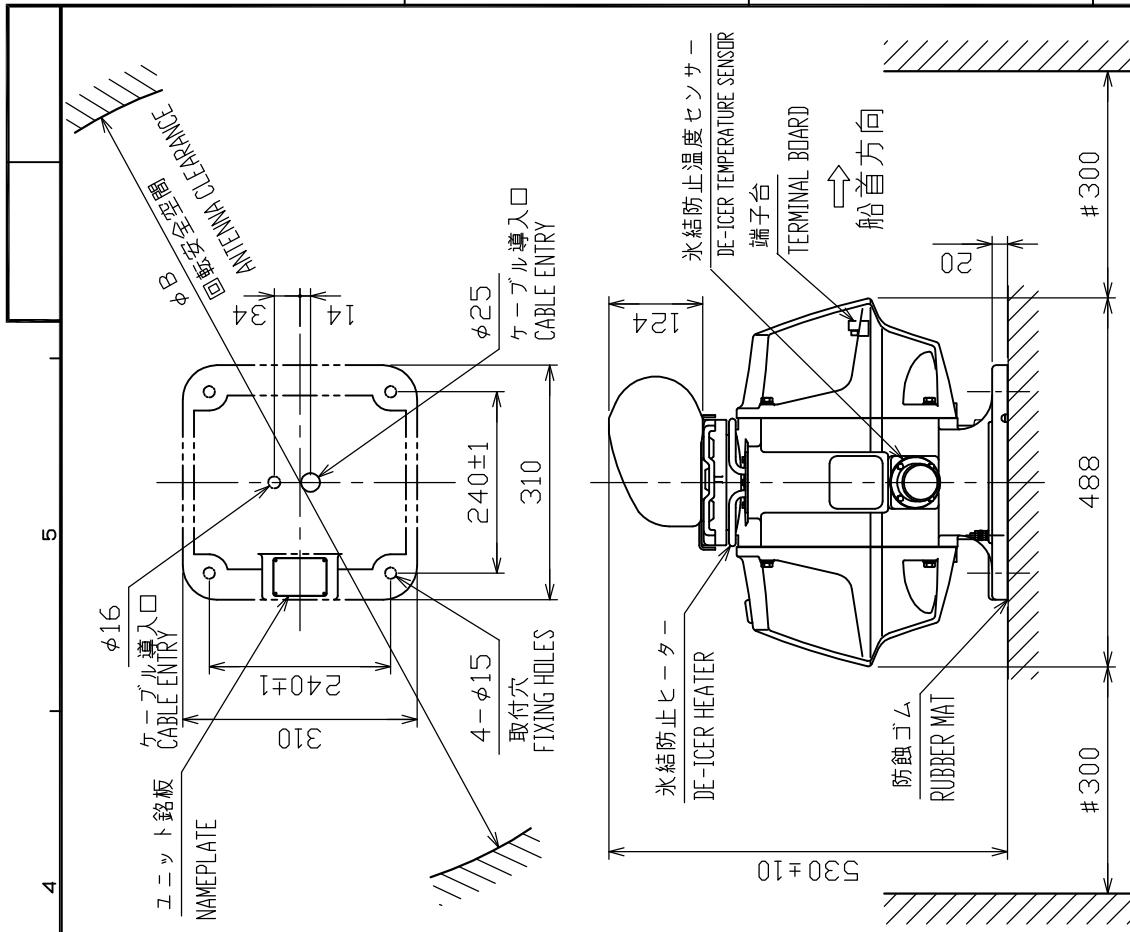

DRAWN	Jan. 5 '04	E. MIYOSHI	TITLE	RSB-096/097-12AF (PM-31)
CHECKED		TAKAHASHI, T	名称	空中線部 (氷結防止付き)
APPROVED		Y. Hattori	外寸図	
SCALE	1/10	MASS 33 kg	NAME	ANTENNA UNIT (V/DE-ICER)
DWG No.	C3519-G25-A	03-154-315G-1		OUTLINE DRAWING

表 1 TABLE 1

寸法区分 (mm) DIMENSIONS	公差 (mm) TOLERANCE
L ≤ 50	± 1.5
50 < L ≤ 100	± 2.5
100 < L ≤ 500	± 3
500 < L ≤ 1000	± 4
1000 < L ≤ 2000	± 5
2000 < L ≤ 4000	± 7

表 2 TABLE 2

アンテナ型式 ANTENNA TYPE	XN-12AF (120c m型)
A: 空中線長 ANTENNA LENGTH (mm)	1260 ± 10
B: 回転安全空間 ANT. CLEARANCE (mm)	1400

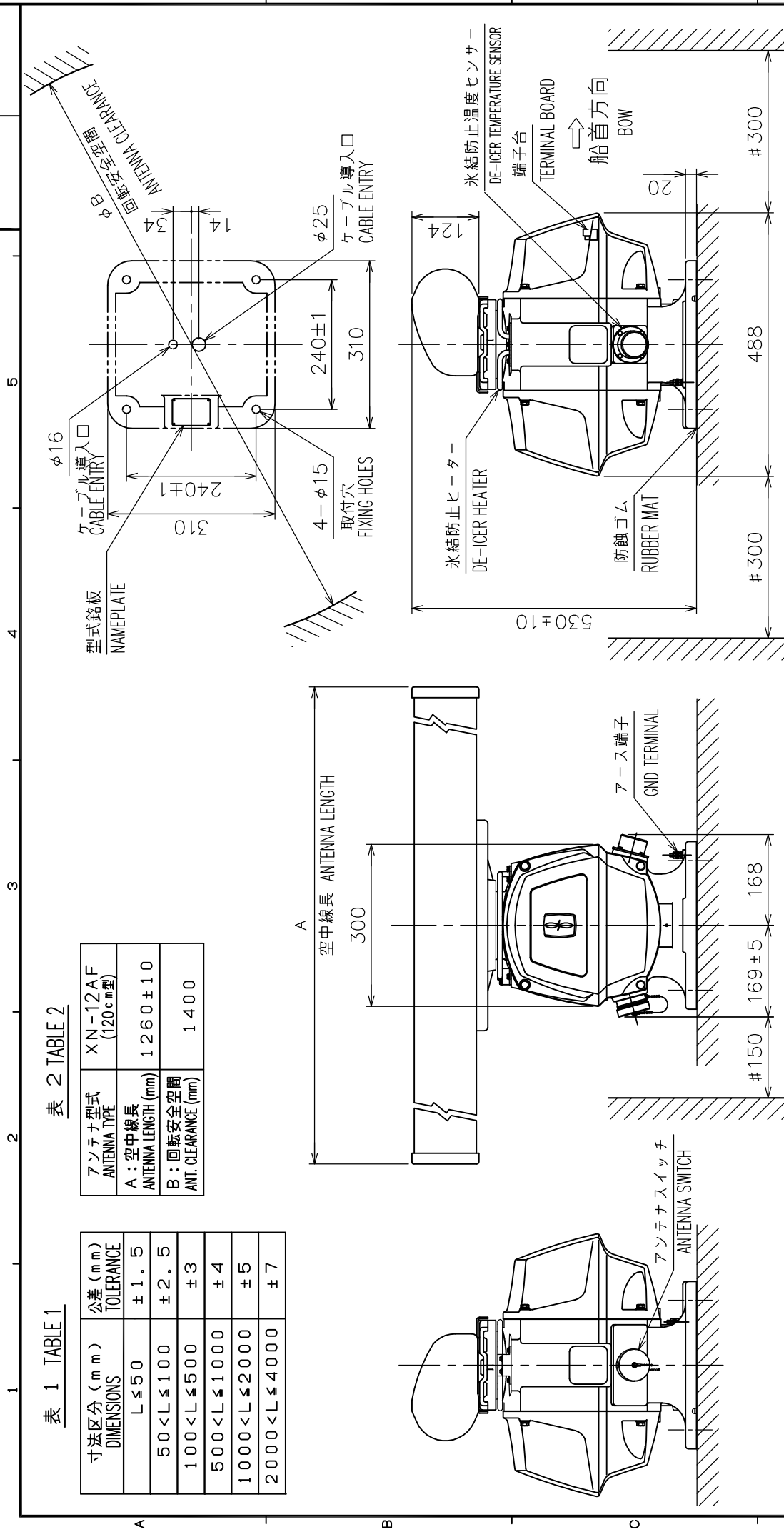

- 注 記
- 1) #印寸法は最小サービスクリアランスとする。
  - 2) 指定外の寸法公差は表1による。
  - 3) 取付用ネジはM12ボルトを使用のこと。
  - 4) A, B寸法は表2による。

- NOTE
1. # MINIMUM SERVICE CLEARANCE.
  2. TABLE 1 INDICATES TOLERANCE OF DIMENSIONS WHICH IS NOT SPECIFIED.
  3. USE M12 BOLTS FOR FIXING THE UNIT.
  4. TABLE 2 INDICATES DIMENSIONS A & B.

DRAWN	Jun. 27 '06	E. MIYOSHI	TITLE	RSB-096/097-12AF
CHECKED		TAKAHASHI, T	名称	空中線部 (氷結防止付き)
APPROVED		Y. Hatoi	外寸図	
SCALE	1/10	MASS 33 kg	NAME	ANTENNA UNIT (W/DE-ICER)
DWG No.	C3519-G26-B	03-154-316G-1		OUTLINE DRAWING



表 1 TABLE 1

寸法区分 (mm) DIMENSION	公差 (mm) TOLERANCE
$L \leq 50$	$\pm 1.5$
$50 < L \leq 100$	$\pm 2.5$
$100 < L \leq 500$	$\pm 3$

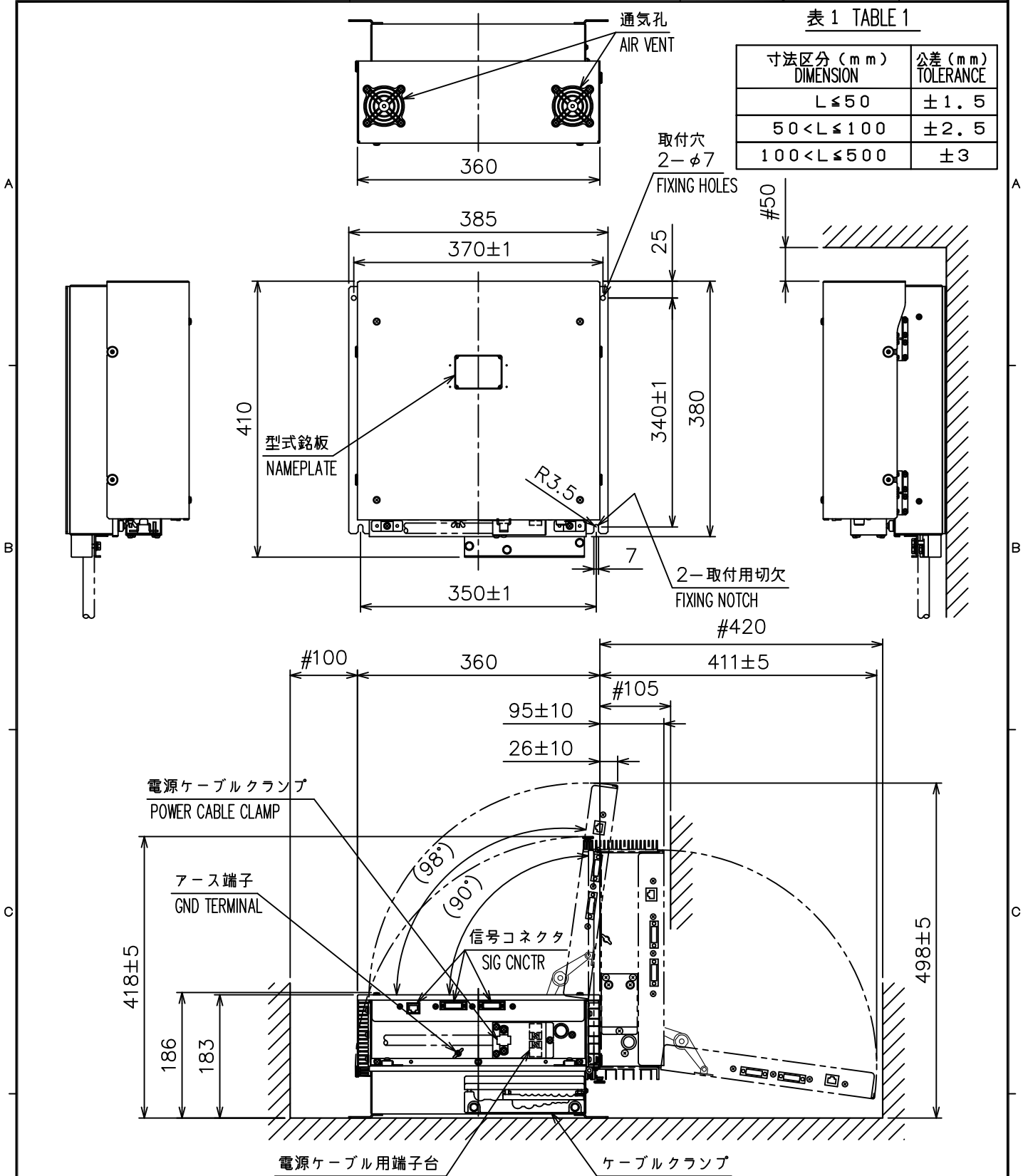

注 記

- 1) #印寸法は最小サービス空間寸法とする。
- 2) 指定外の寸法公差は表 1 による。
- 3) 取付用ネジは M6 ボルト、またはコーチボルト呼び径 6 を使用のこと。

NOTE

1. #: MINIMUM SERVICE CLEARANCE.
2. TABLE 1 INDICATES TOLERANCE OF DIMENSIONS WHICH IS NOT SPECIFIED.
3. USE M6 BOLTS OR COACH SCREWS φ6 FOR FIXING THE UNIT.

DRAWN	May 15 '07 T. YAMASAKI	TITLE	RPU-013/016
CHECKED	May 15 '07 T. TAKENO	名称	制御部
APPROVED	May 17 '07 R. Esumi		外寸図
SCALE	1/8 MASS 10 ±10% kg	NAME	PROCESSOR UNIT
DWG. No.	C3519-G03-D	REF. No.	03-163-800G-3
		OUTLINE DRAWING	

表 1 TABLE 1

寸法区分 (mm) DIMENSIONS	公差 (mm) TOLERANCE
L ≤ 50	±1.5
50 < L ≤ 100	±2.5
100 < L ≤ 500	±3
500 < L ≤ 1000	±4

型式銘板  
NAMEPLATE

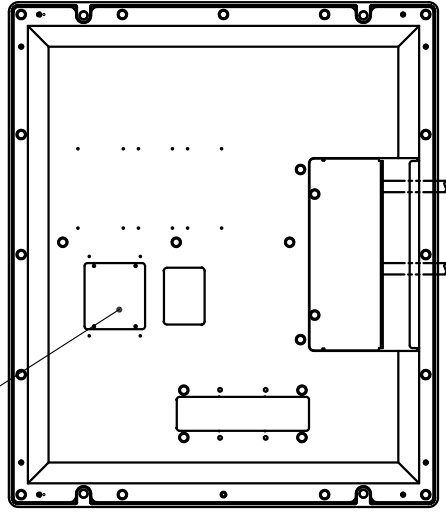
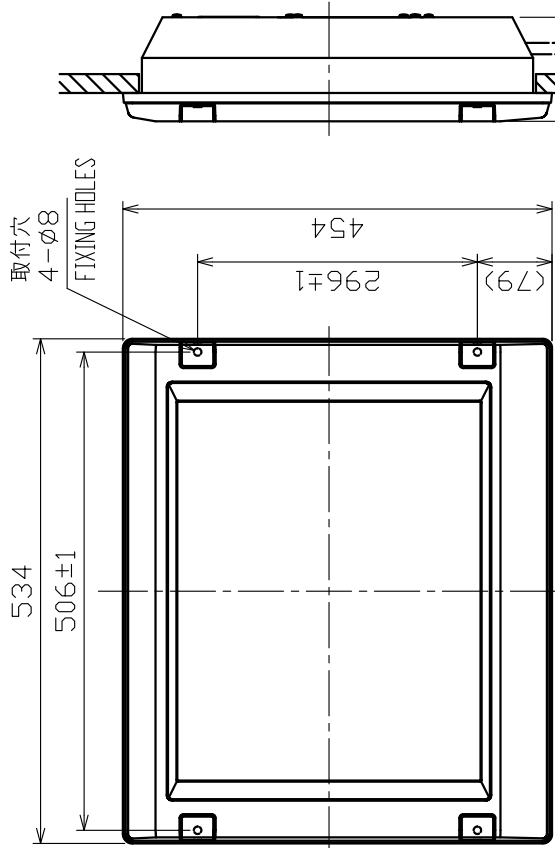

506±1

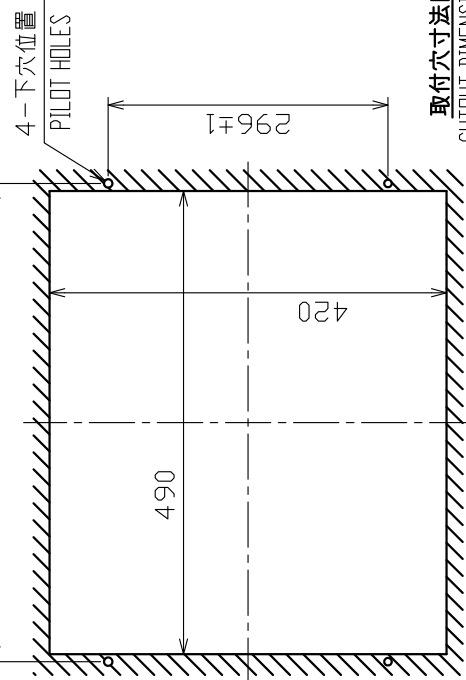

取付穴寸法図  
CUTOUT DIMENSIONS

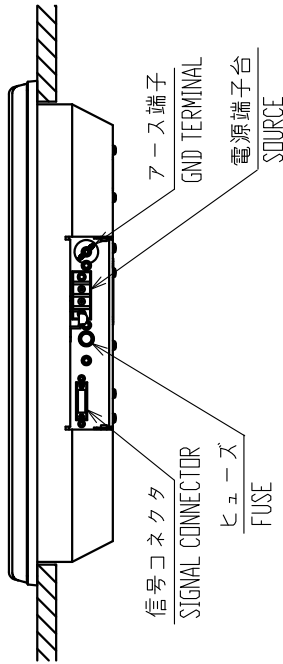
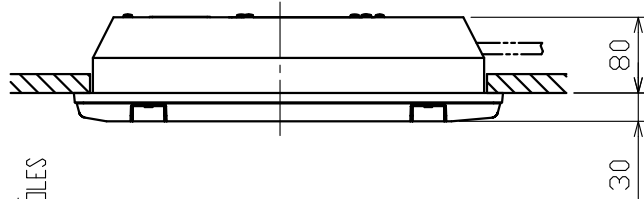

- 注 記 1) 指定外の寸法公差は表 1 による。  
 2) 取付には + トラスタップピンネジ呼び径 6×30 を使用のこと。
- NOTE 1. TABLE 1 INDICATES TOLERANCE OF DIMENSIONS WHICH IS NOT SPECIFIED.  
 2. USE TAPPING SCREWS φ6×30 FOR FIXING THE UNIT.

DRAWN	1/Sep/2010	T.YAMASAKI	TITLE	MU-201CR
CHECKED	1/Sep/2010	T.TAKAHASHI	名称	表示部 (埋込装備)
APPROVED	1/Sep/2010	Y.NISHIYAMA	外寸図	MONITOR UNIT (FLUSH MOUNT)
SCALE	1/8	質量 11 kg	図名	OUTLINE DRAWING
DWG.No.	C3519-G05-C		REF.No.	03-163-110G-2

表 1 TABLE 1

寸法区分 (mm) DIMENSIONS	公差 (mm) TOLERANCE
L ≤ 50	± 1.5
50 < L ≤ 100	± 2.5
100 < L ≤ 500	± 3
500 < L ≤ 1000	± 4

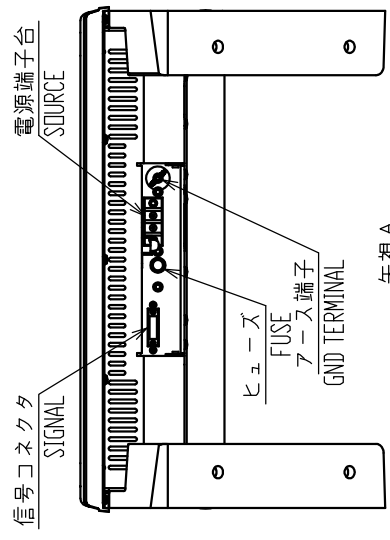

矢視 A  
VIEW A

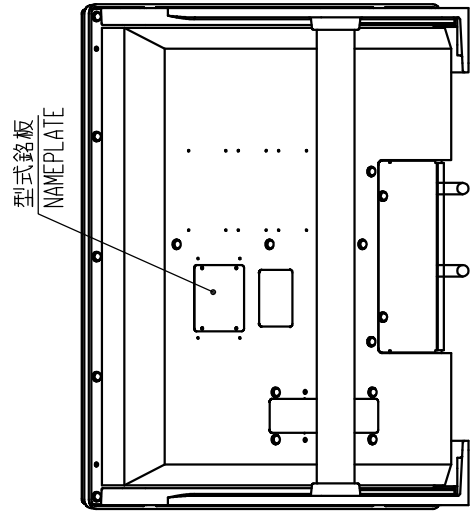
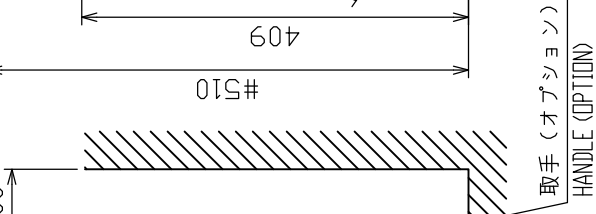
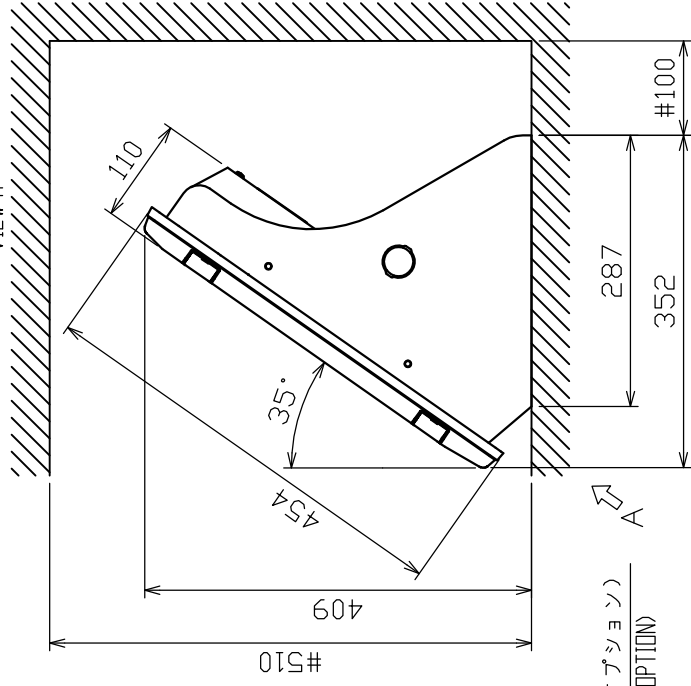

注 記

- 1) #印寸法は最小サービス空間寸法とする。
- 2) 指定外の寸法公差は表1による。
- 3) 取付にはM10ボルトまたはコーチボルト呼び径9を使用のこと。

NOTE

1. # MINIMUM SERVICE CLEARANCE.
2. TABLE 1 INDICATES TOLERANCE OF DIMENSIONS WHICH IS NOT SPECIFIED.
3. USE M10 BOLTS OR COACH SCREWS φ9 FOR FIXING THE UNIT.

DRAWN	Jan. 7 '04	E. MIYOSHI	TITLE	MU-200CR
CHECKED	Jan. 7 '04	TAKAHASHI, T	名称	表示部 (卓上装備)
APPROVED	Jan. 7 '04	Y. Hatai	外寸図	
SCALE	1/8	WASS 17.0 kg	NAME	MONITOR UNIT (DESKTOP MOUNT)
DWG.No.	C3519-G04-B			OUTLINE DRAWING
				03-163-100G-2



表 1 TABLE 1

寸法区分 (mm) DIMENSIONS	公差 (mm) TOLERANCE
L ≤ 50	± 1.5
50 < L ≤ 100	± 2.5
100 < L ≤ 500	± 3
500 < L ≤ 1000	± 4



型式銘板  
NAMEPLATE

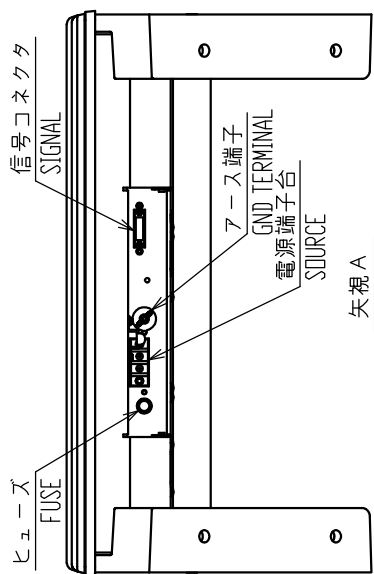
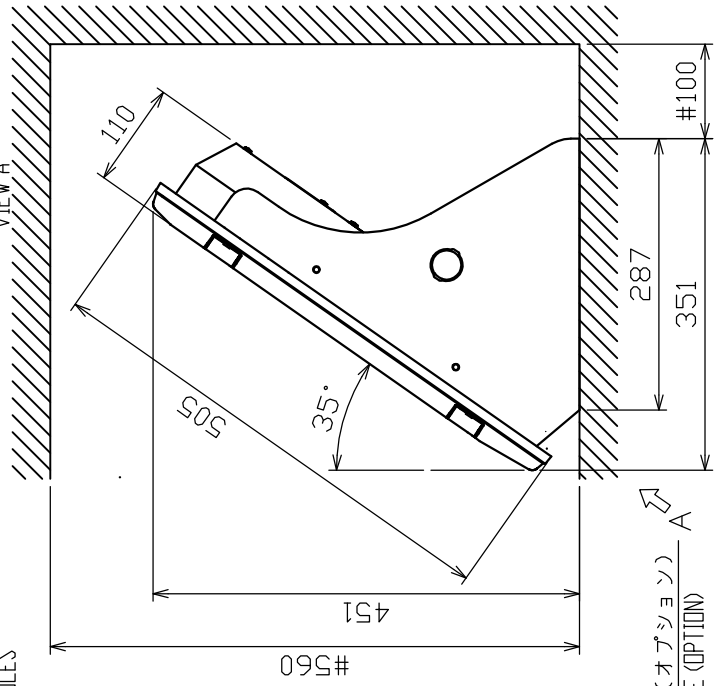
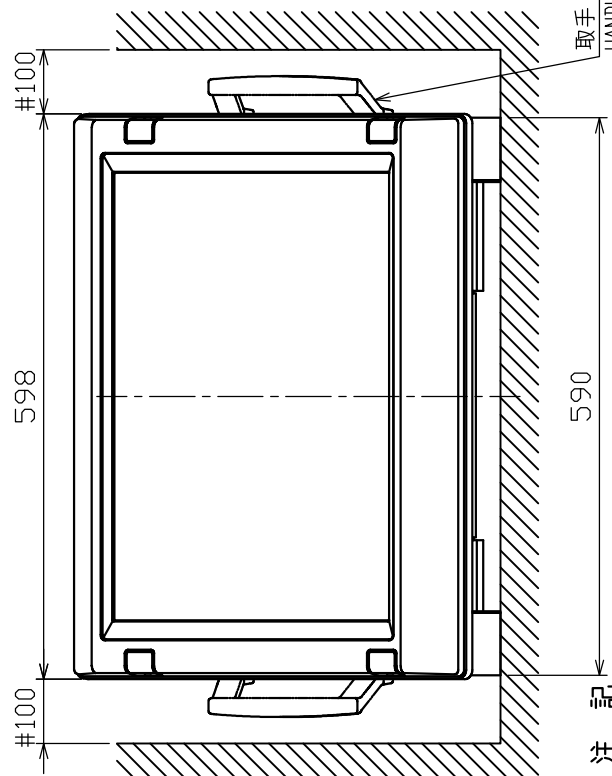
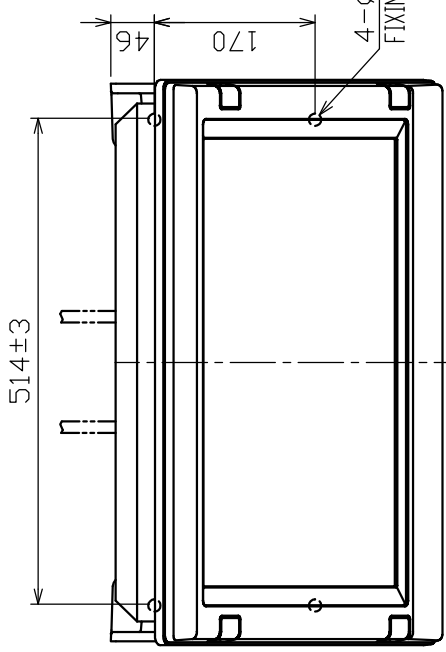
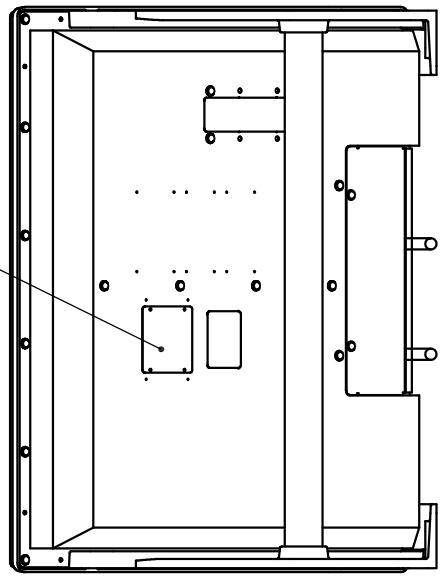

注 記  
1) #印寸法は最小サービスクリアランスとする。  
2) 指定外の寸法公差は表1による。  
3) 取付にはM10ボルトまたはコーチボルト呼び径9を使用のこと。

- NOTE
- # MINIMUM SERVICE CLEARANCE.
  - TABLE 1 INDICATES TOLERANCE OF DIMENSIONS WHICH IS NOT SPECIFIED.
  - USE M10 BOLTS OR COACH SCREWS φ9 FOR FIXING THE UNIT.

DRAWN	Jan. 7 '04	E. MIYOSHI	TITLE	MU-231CR
CHECKED		TAKAHASHI, T	名称	表示部 (卓上装備)
APPROVED		Y. Ho,toi	外寸図	
SCALE	1/8	MASS 22 kg	NAME	MONITOR UNIT (DESKTOP MOUNT)
DWG.No.	C3524-G01-B	03-163-200G-2		OUTLINE DRAWING

表 1 TABLE 1

寸法区分 (mm) DIMENSIONS	公差 (mm) TOLERANCE
L ≤ 50	±1.5
50 < L ≤ 100	±2.5
100 < L ≤ 500	±3
500 < L ≤ 1000	±4

型式銘板  
NAMEPLATE

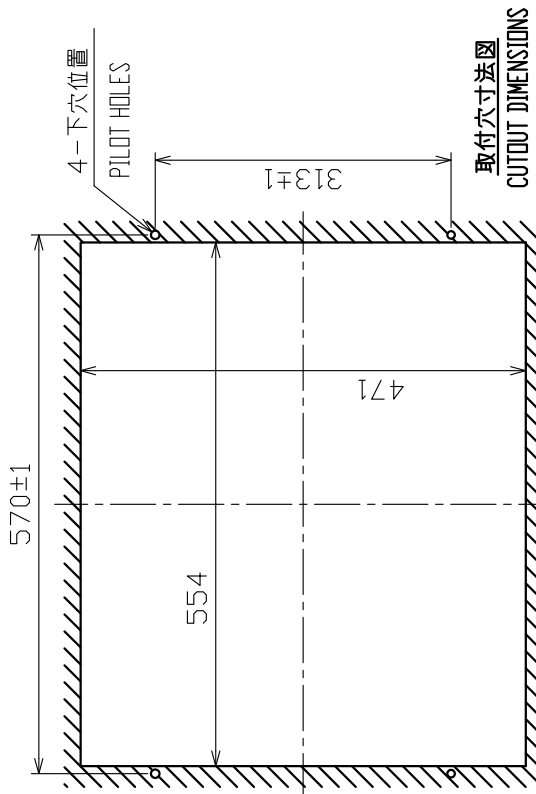
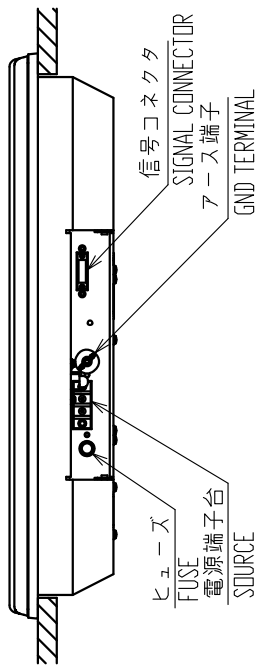
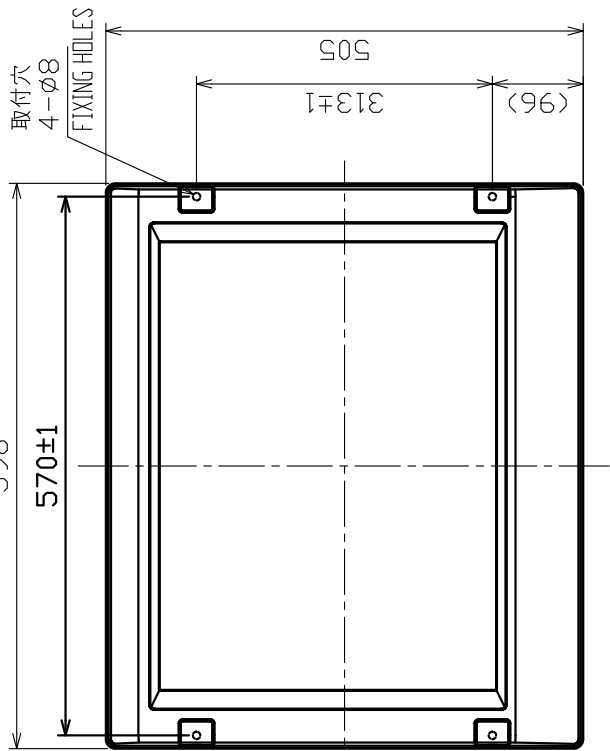
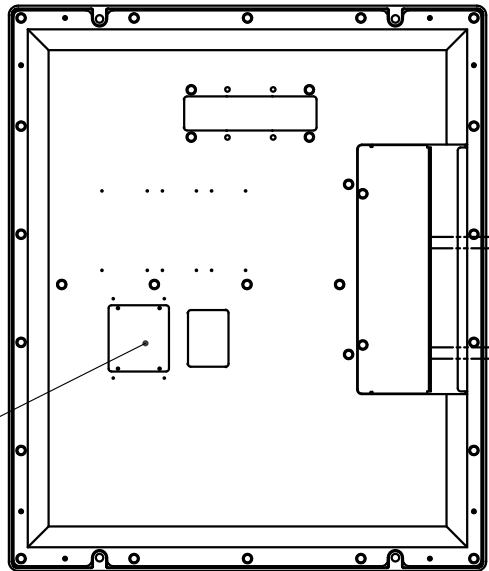

取付穴寸法図  
CUTOUT DIMENSIONS

- 注 記 1) 指定外の寸法公差は表 1 による。  
 2) 取付には + トラスタップピンネジ呼び径 6 × 30 を使用のこと。
- NOTE 1. TABLE 1 INDICATES TOLERANCE OF DIMENSIONS WHICH IS NOT SPECIFIED.  
 2. USE TAPPING SCREWS  $\phi 6 \times 30$  FOR FIXING THE UNIT.

DRAWN	1/Sep/2010	T.YAMASAKI	TITLE	MU-231CR
CHECKED	1/Sep/2010	T.TAKAHASHI	名称	表示部 (埋込装備)
APPROVED	1/Sep/2010	Y.NISHIYAMA	外寸図	
SCALE	1/8	質量 15 kg	NAME	MONITOR UNIT (FLUSH MOUNT)
FIG.No.	C3524-G02-C	REF.No.	03-163-210G-2	OUTLINE DRAWING

表 1 TABLE 1

寸法区分 (mm) DIMENSION	公差 (mm) TOLERANCE
L ≤ 50	±1.5
50 < L ≤ 100	±2.5
100 < L ≤ 500	±3

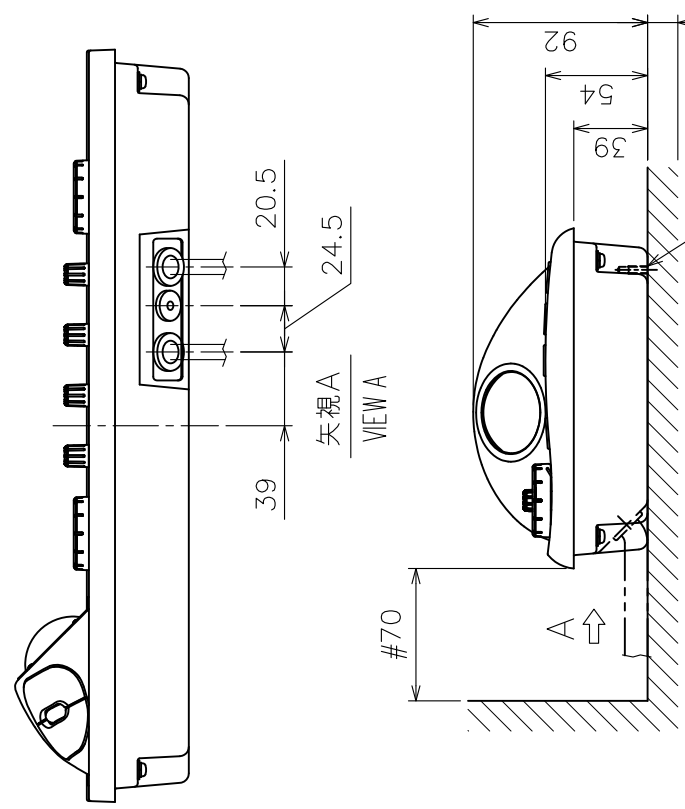
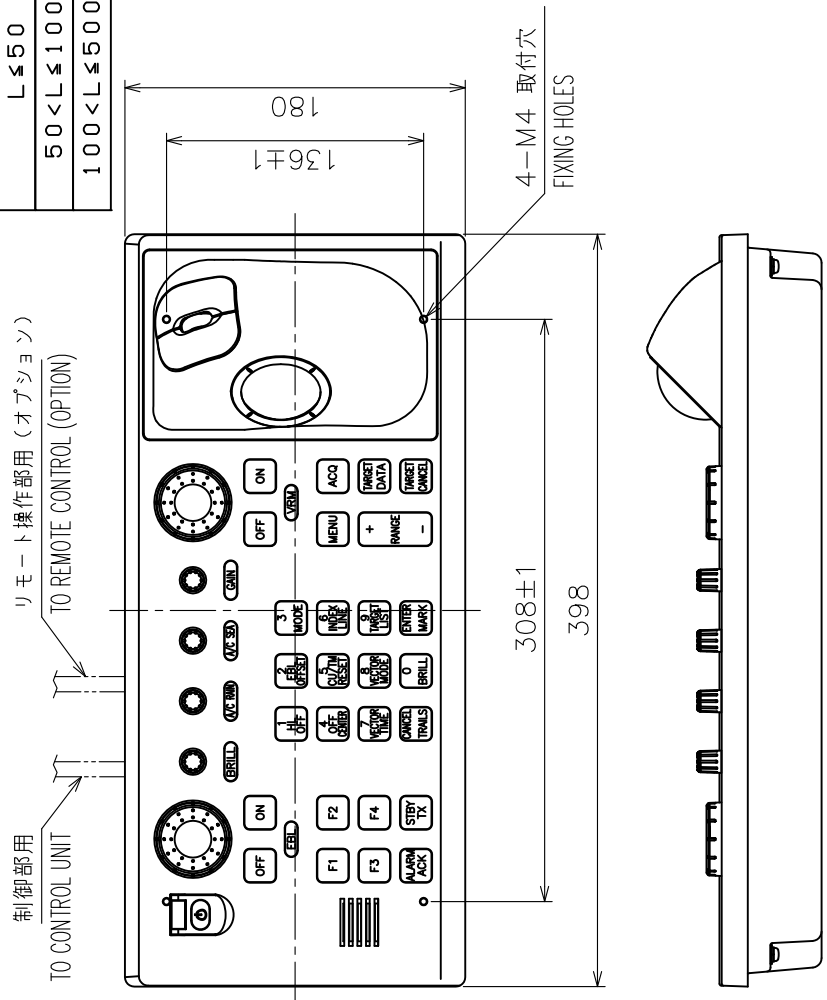

- 注 記
- 1) # 印寸法は最小サービス空間寸法とする。
  - 2) 指定外の寸法公差は表 1 による。
  - 3) 取付用ネジはセムスB (M4X12) を使用のこと。  
取付面板厚 (t) は  $2 \leq t \leq 4$  とする。それ以外は、  
ネジ長さを  $(t + 7.8) \pm 2$  とする。

- NOTE
1. # MINIMUM SERVICE CLEARANCE.
  2. TABLE 1 INDICATES TOLERANCE OF DIMENSIONS WHICH IS NOT SPECIFIED.
  3. USE M4x12 SCREWS FOR FIXING THE UNIT.  
THICKNESS OF MOUNTING BOARD(t) SHOULD BE  $2 \leq t \leq 4$ .  
FOR THICKER ONE USE SCREW LENGTH:  $(t+7.8) \pm 2$ .

DRAWN	Jun. 11 '08	T. YAMASAKI	TITLE	RCU-014/020
CHECKED	Jun. 11 '08	I. TAKENO	名称	操作部
APPROVED	Jan. 18 '08	R. Esumi	外寸図	
SCALE	1/4	質量 3.7 kg	NAME	CONTROL UNIT
DWG.No.	C3519-G06-E	03-163-750G-4	OUTLINE DRAWING	



表 1 TABLE 1

寸法区分 (mm) DIMENSION	公差 (mm) TOLERANCE
L ≤ 50	± 1.5
50 < L ≤ 100	± 2.5
100 < L ≤ 500	± 3

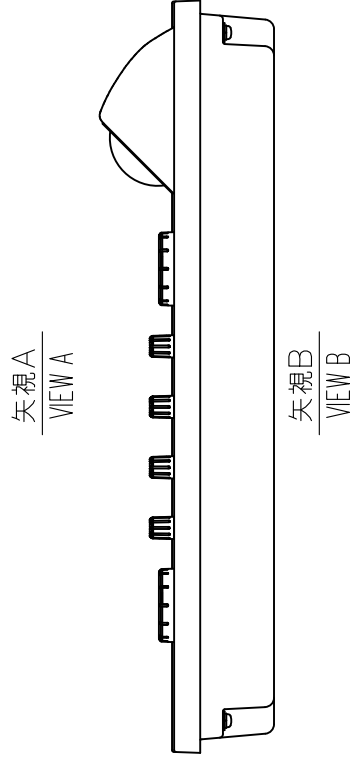
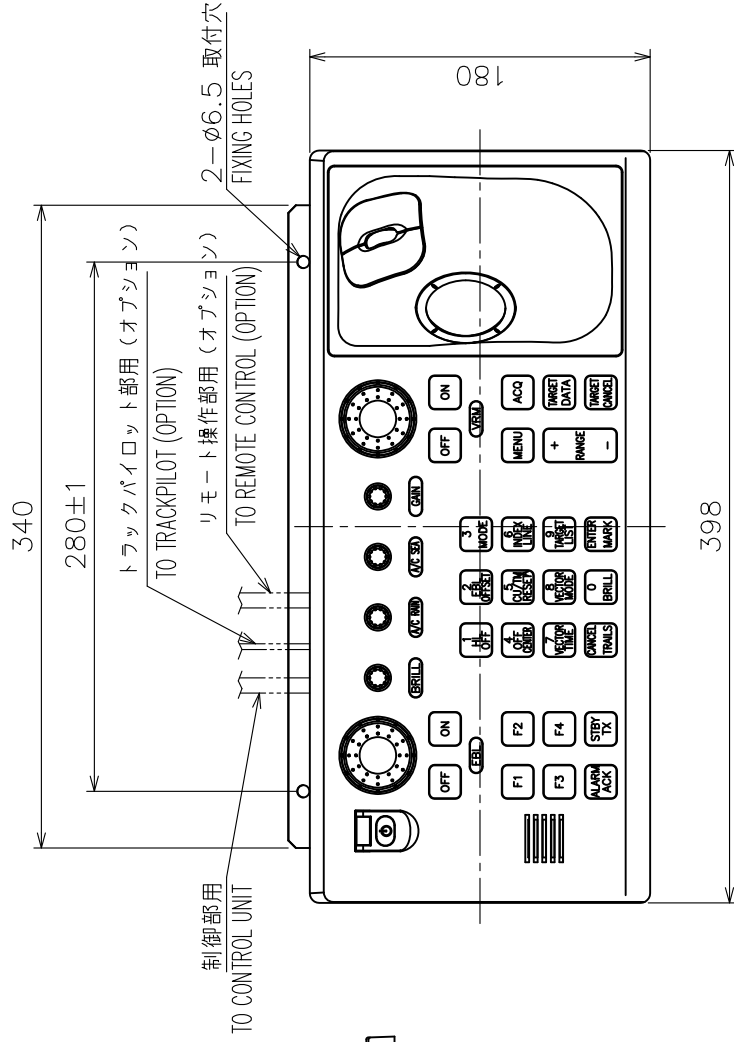
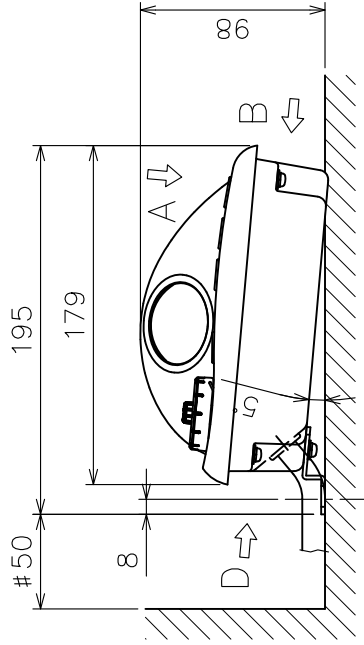
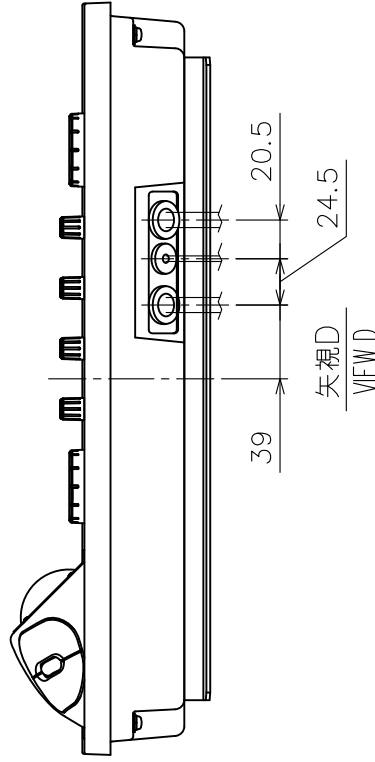

DRAWN	Apr. 19 '07 T. YAMASAKI	TITLE	RCU-014/020
CHECKED	Apr. 19 '07 T. TAKENO	名称	操作部 (直付金具装備)
APPROVED	Apr. 23 '07 R. Esumi	FOR-2117 SER. FAR-2117 SER.	外寸図
SCALE	1/4 MASS 4.0 kg	NAME	CONTROL UNIT (TABLETOP MOUNT W/ KB PLATE)
DWG. No.	C3524-G05-C		OUTLINE DRAWING

- 注 記 1) #印寸法は最小サービス空間寸法とする。  
 2) 指定外の寸法公差は表 1 による。  
 3) 取付用ネジはトラスタップピンネジ呼び径6、またはM6ボルトを使用のこと。
- NOTE 1. # MINIMUM SERVICE CLEARANCE.  
 2. TABLE 1 INDICATES TOLERANCE OF DIMENSIONS WHICH IS NOT SPECIFIED.  
 3. USE TAPPING SCREW φ6 OR M6 BOLTS FOR FIXING THE UNIT.



表 1 TABLE 1

寸法区分 (mm) DIMENSION	公差 (mm) TOLERANCE
L ≤ 50	± 1.5
50 < L ≤ 100	± 2.5
100 < L ≤ 500	± 3

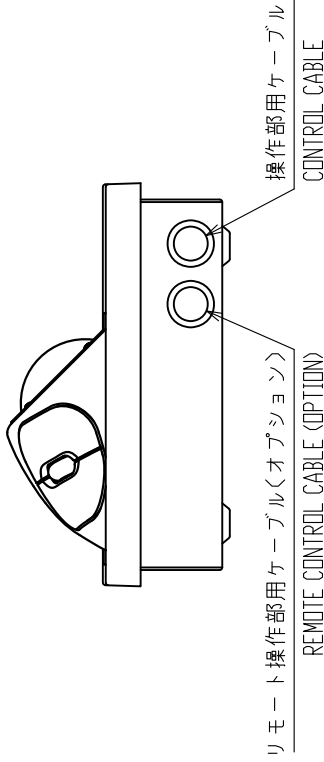
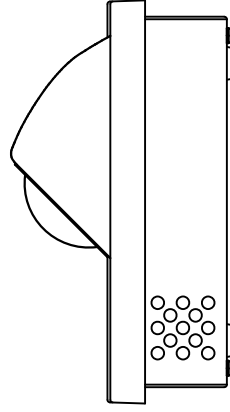
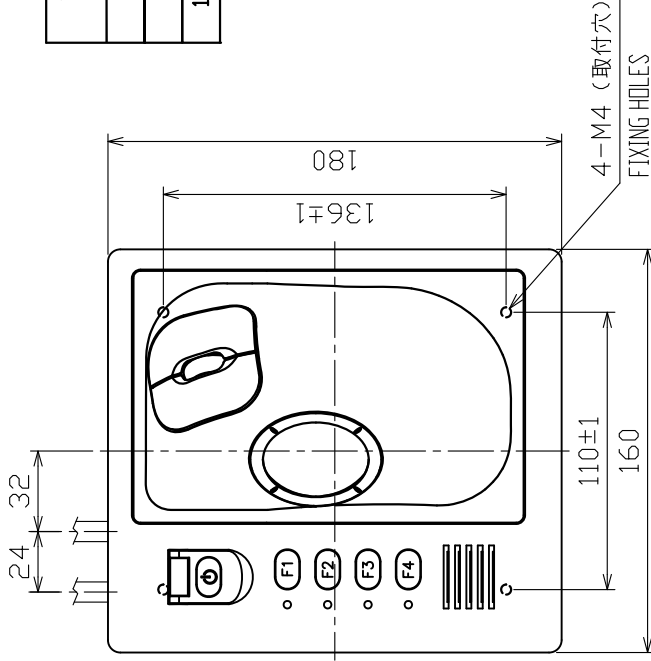

矢視A  
VIEW A

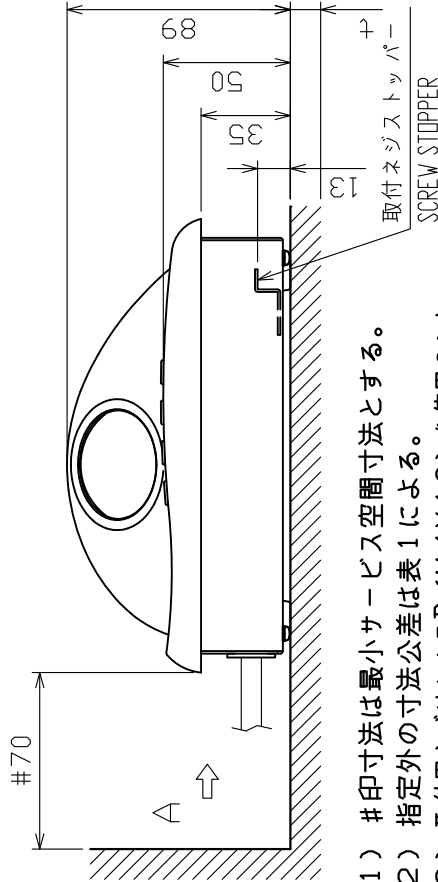

- 注 記
- 1) #印寸法は最小サービス空間寸法とする。
  - 2) 指定外の寸法公差は表1による。
  - 3) 取付用ネジはセムスB (M4×12) を使用のこと。  
取付面板厚(τ)は2 ≤ τ ≤ 5とする。それ以外は、  
ネジ長さを (τ + 7.8) ± 2とする。

- NOTE
1. # MINIMUM SERVICE CLEARANCE.
  2. TABLE 1 INDICATES TOLERANCE OF DIMENSIONS WHICH IS NOT SPECIFIED.
  3. USE M4x12 SCREWS FOR FIXING THE UNIT.  
THICKNESS OF MOUNTING BEARD(τ) SHOULD BE 2 ≤ τ ≤ 5.  
FOR THICKER ONE USE SCREW LENGTH: (τ+7.8)±2.

DRAWN	Apr. 17 '07	T. YAMASAKI	TITLE	RCU-015/015FEA
CHECKED	Apr. 17 '07	T. TAKENO	名称	操作部 (卓上装備)
APPROVED	Apr. 23 '07	R. Esumi	外寸図	
SCALE	1/3	質量 2.4 kg 質量(10mケーブルを含む) MASS V/ 10m CABLE	NAME	CONTROL UNIT (DESKTOP MOUNT)
DWG.No.	C3519-G13-C	REF.No.	03-163-785G-2	OUTLINE DRAWING

表 1 TABLE 1

寸法区分 (mm) DIMENSION	公差 (mm) TOLERANCE
L ≤ 50	± 1.5
50 < L ≤ 100	± 2.5
100 < L ≤ 500	± 3

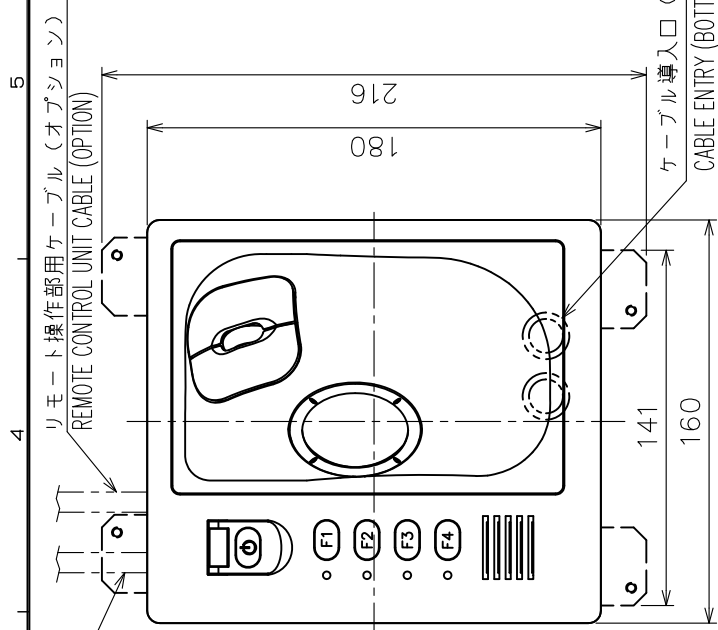
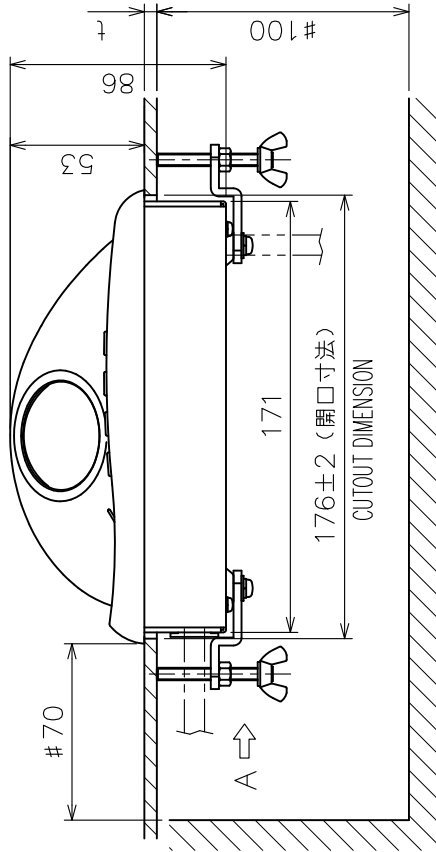
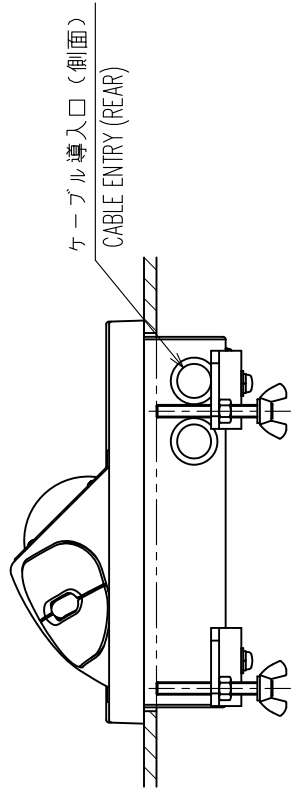

注 記

- 1) #印寸法は最小サービスペース寸法とする。
- 2) 指定外の寸法公差は表 1 による。
- 3) ケーブル導入口は側面・底面から選択のこと。
- 4) 取付面板厚 (t) は最大 1.0 とする

NOTE

1. # MINIMUM SERVICE CLEARANCE.
2. TABLE 1 INDICATES TOLERANCE OF DIMENSIONS WHICH IS NOT SPECIFIED.
3. SELECT CABLE ENTRY FROM REAR OR SIDE.
4. THICKNESS OF MOUNTING BOARD (t) SHOULD BE MAX. 1.0.

DRAWN	Apr. 19 '07	I. YAMASAKI	TITLE	RCU-015/015FEA
CHECKED	Apr. 19 '07	T. TAKENO	名称	操作部 (埋込装備)
APPROVED	Apr. 23 '07	R. Esumi	外寸図	
SCALE	1/3	質量 2.5 kg	NAME	CONTROL UNIT (FLUSH MOUNT)
DWG.No.	C3519-G14-D	質量 (ケーブルを含む) MASS INCLUDES CABLE		OUTLINE DRAWING
		質量 (100mmケーブルを含む) MASS INCLUDES 100mm CABLE		
		03-163-786G-2		



表 1 TABLE 1

寸法区分 (mm) DIMENSIONS	公差 (mm) TOLERANCE
L ≤ 50	± 1.5
50 < L ≤ 100	± 2.5
100 < L ≤ 500	± 3

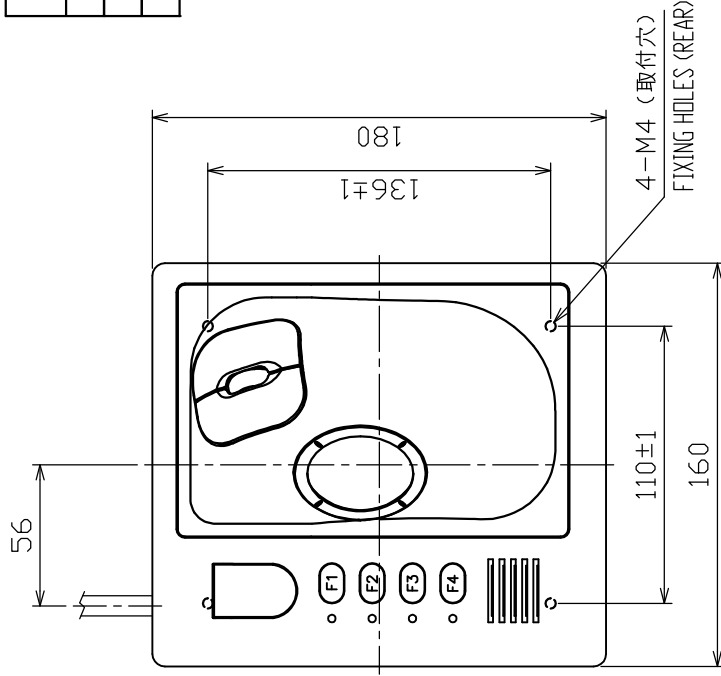

NOTE

- # MINIMUM SERVICE CLEARANCE.
- TABLE 1 INDICATES TOLERANCE OF DIMENSIONS WHICH IS NOT SPECIFIED.
- USE M4x12 SCREWS FOR FIXING. THICKNESS OF MOUNTING PANEL SHOULD BE  $2 \leq t \leq 5$ . FOR USING GREATER THICKNESS, USE SCREW WHOSE LENGTH IS  $(t+7.8) \pm 2$ .

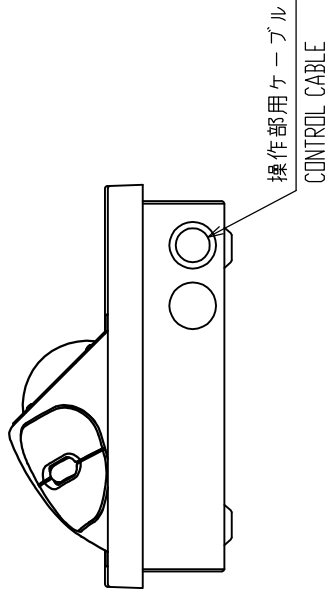
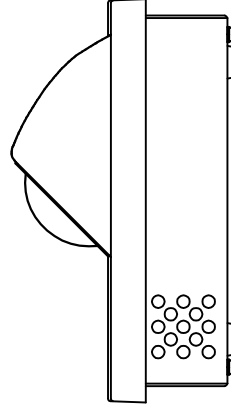

矢視A  
VIEW A

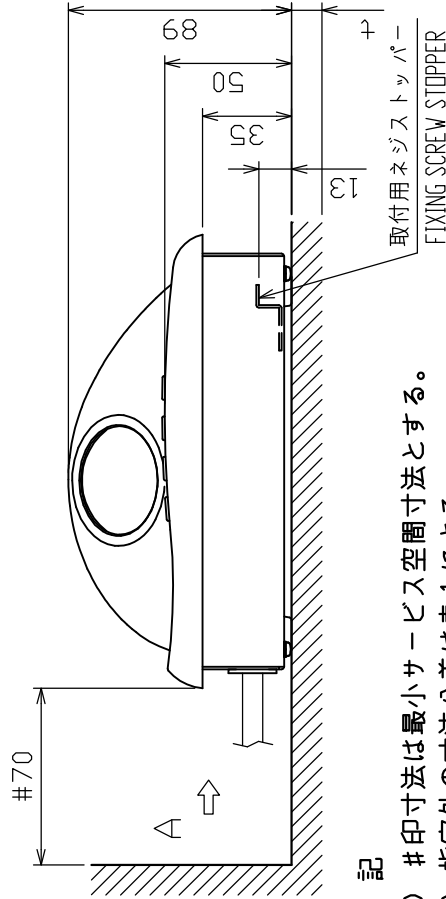

注 記

- # 印寸法は最小サービス空間寸法とする。
- 指定外の寸法公差は表 1 による。
- 取付用ネジはセムスB (M4X12) を使用のこと。  
取付面板厚(t)は  $2 \leq t \leq 5$  とする。  
それ以外はネジ長さ  $(t+7.8) \pm 2$  のセムスBを使用のこと。

DRAWN	Feb. 7 '07	E. MIYOSHI	TITLE	RCU-016
CHECKED		TAKAHASHI, T	名称	操作部 (卓上装備)
APPROVED		Y. Hatai	外寸図	
SCALE	1/3	質量 2.4 kg 寸法は10mm単位で書き込む。 質量 W / 10mm CABLE	NAME	CONTROL UNIT (DESKTOP MOUNT)
DWGNo.	C3519-G16-C	03-163-780G-4		OUTLINE DRAWING

表 1 TABLE 1

寸法区分 (mm) DIMENSIONS	公差 (mm) TOLERANCE
L ≤ 50	± 1.5
50 < L ≤ 100	± 2.5
100 < L ≤ 500	± 3

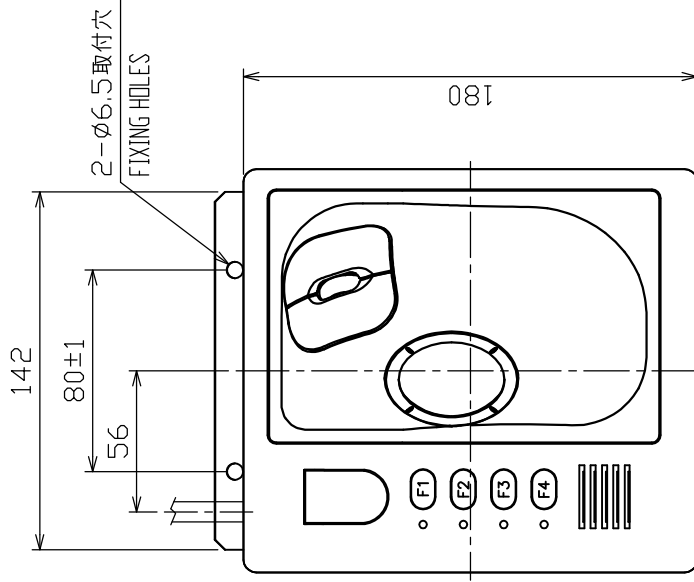

矢視 A  
VIEW A

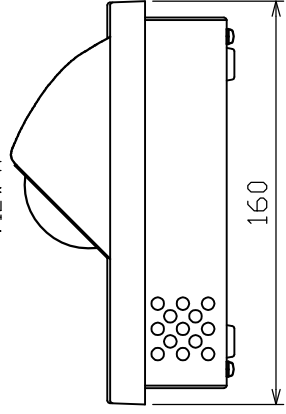

矢視 B  
VIEW B

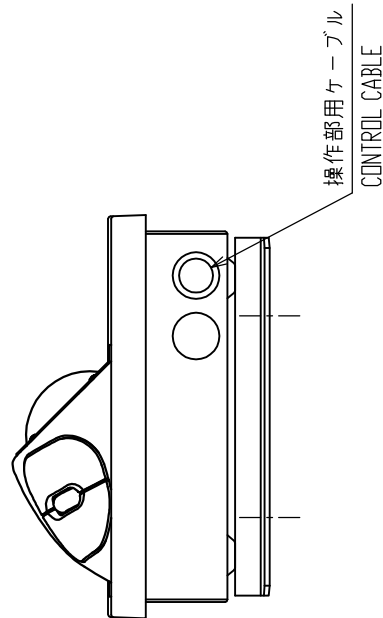

矢視 D  
VIEW D

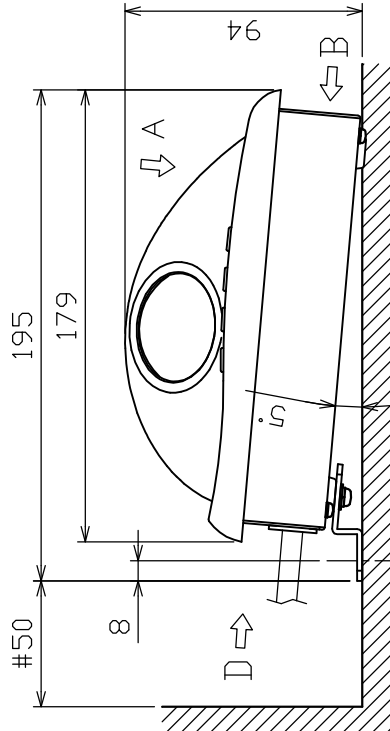

注 記

- 1) #印寸法は最小サービスクリアランスとする。
- 2) 指定外の寸法公差は表 1 による。
- 3) 取付用ネジはトラスチックピンネジ呼び径6、またはM6ボルトを使用のこと。

NOTE

1. # MINIMUM SERVICE CLEARANCE.
2. TABLE 1 INDICATES TOLERANCE OF DIMENSIONS, WHICH IS NOT SPECIFIED.
3. USE TAPPING SCREWS #6 OR M6 BOLTS FOR FIXING THE UNIT.

DRAWN	Feb. 5 '07	E. MIYOSHI	TITLE	RCU-016
CHECKED		TAKAHASHI, T	名称	操作部 (取付金具装備)
APPROVED		Y. Hatai	外寸図	
SCALE	1/3	MASS 2.5 100 CABLE MASS W/ JON. CABLE	NAME	CONTROL UNIT (TABLETOP MOUNT W/ FIXTURE)
DWG. No.	C3519-G12-C	03-163-782G-2		OUTLINE DRAWING

操作部用ケーブル  
CONTROL UNIT CABLE

表 1 TABLE 1

寸法区分 (mm) DIMENSIONS	公差 (mm) TOLERANCE
$L \leq 50$	$\pm 1.5$
$50 < L \leq 100$	$\pm 2.5$
$100 < L \leq 500$	$\pm 3$

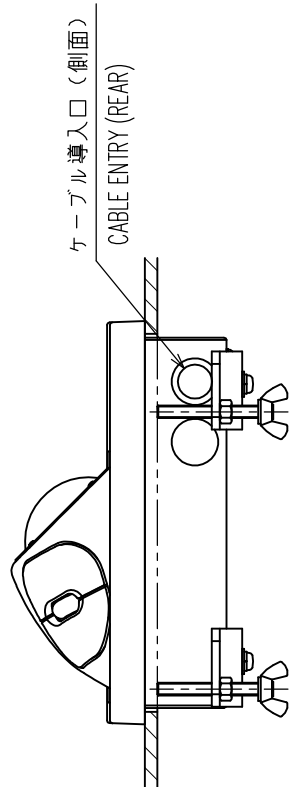
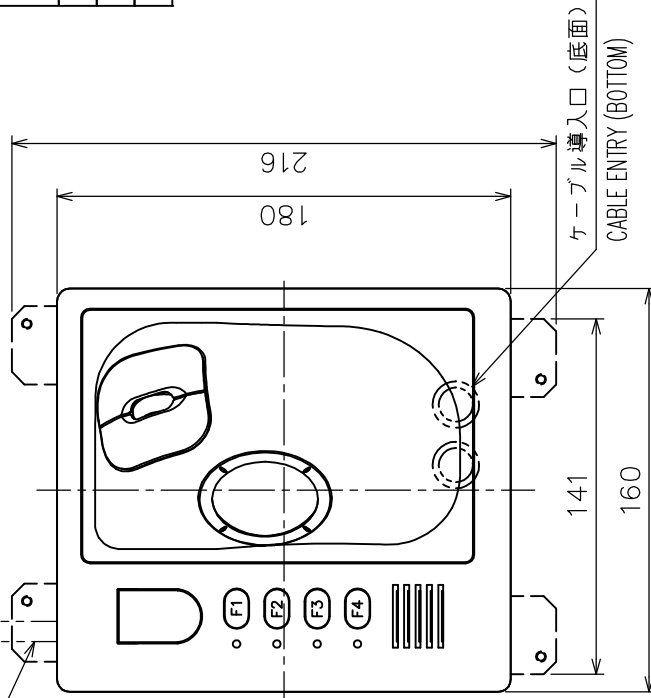

矢視 A  
VIEW A

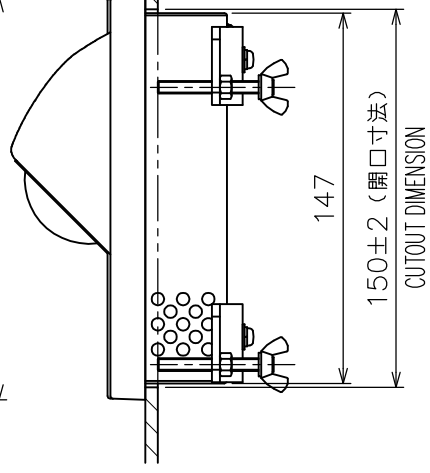
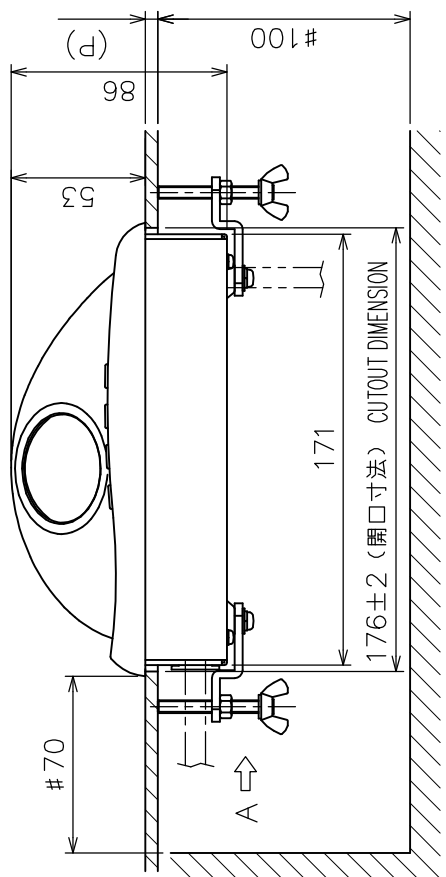

注 記

- 1) # 印寸法は最小サービス空間寸法とする。
- 2) 指定外の寸法公差は表 1 による。
- 3) ケーブル導入口は側面・底面から選択のこと。
- 4) 壁の厚さ (P) は最大 10 とする

NOTE

1. # MINIMUM SERVICE CLEARANCE.
2. TABLE 1 INDICATES TOLERANCE OF DIMENSIONS WHICH IS NOT SPECIFIED.
3. SELECT CABLE ENTRY FROM REAR OR SIDE.
4. THICKNESS (P): 10 mm MAX.

DRAWN	Feb. 6 '07	E. MIYOSHI	TITLE	RCU-016
CHECKED		TAKAHASHI, T	名称	操作部 (埋込装備)
APPROVED		Y. Hotoi	外寸図	
SCALE	1/3	WASS 2.5 質量は10mmケーブルを含む。	NAME	CONTROL UNIT (FLUSH MOUNT)
DWG.No.	C3519-G11-D	03-163-781G-4	OUTLINE DRAWING	

表 1 TABLE 1

寸法区分 (mm) DIMENSIONS	公差 (mm) TOLERANCE
L ≤ 50	±1.5
50 < L ≤ 100	±2.5
100 < L ≤ 500	±3

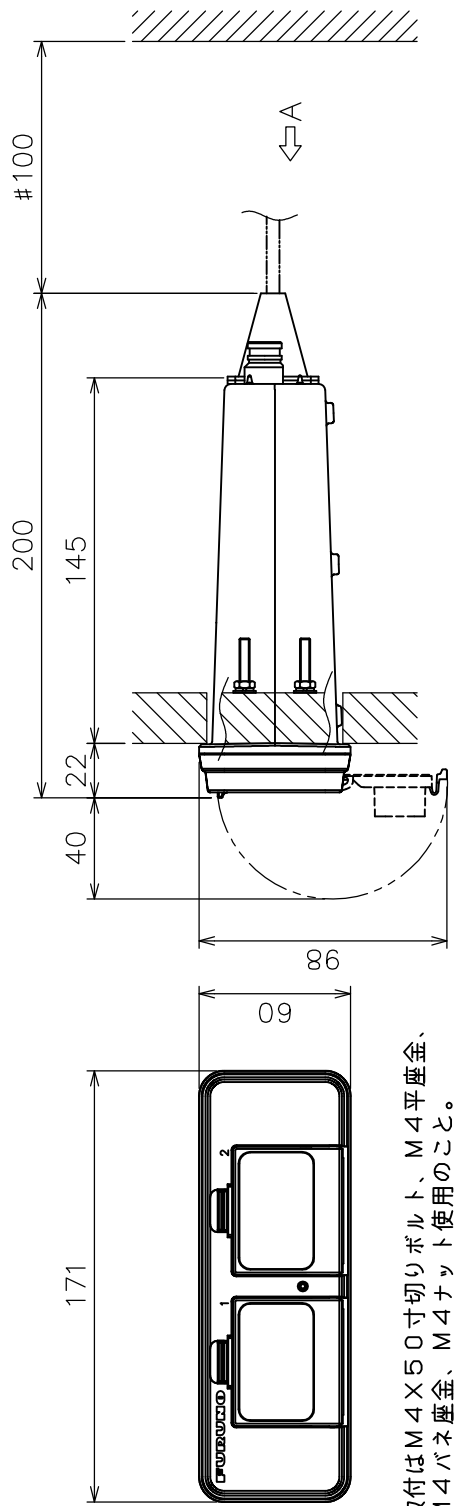
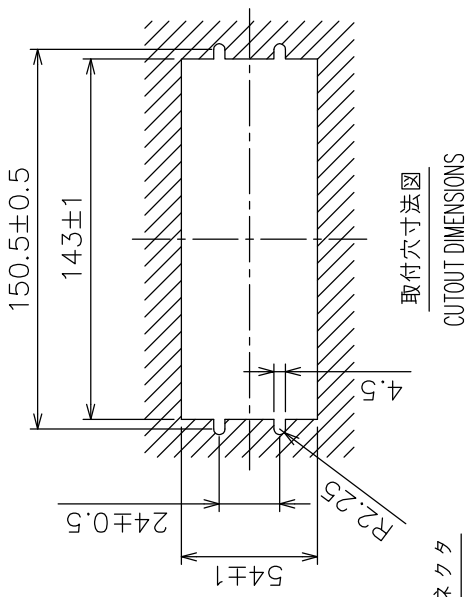
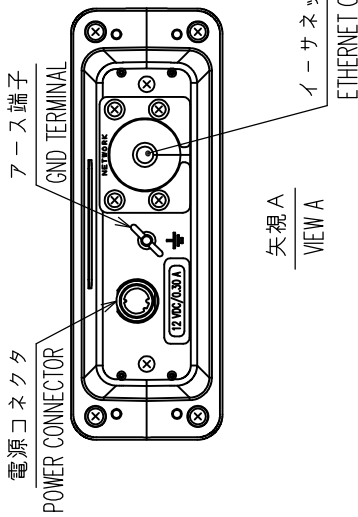
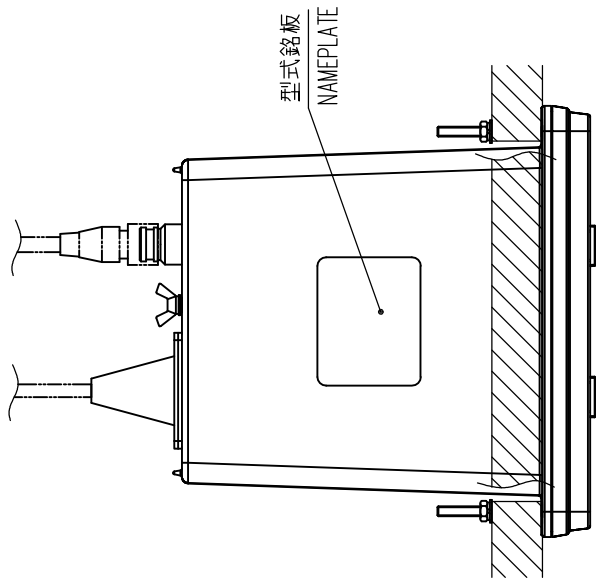

- 注 記
- 1) 取付はM4X50寸切りボルト、M4平座金、M4バネ座金、M4ナット使用のこと。
  - 2) #印寸法は最小サービスクリアランスとする。
  - 3) 指定外の寸法公差は表1による。
- NOTE
1. USE M4X50 BOLTS, M4 FLAT WASHERS, M4 SPRING WASHER AND M4 NUTS FOR FIXING.
  2. # MINIMUM SERVICE CLEARANCE.
  3. TABLE 1 INDICATES TOLERANCE OF DIMENSIONS WHICH IS NOT SPECIFIED.

DRAWN	Mr. 29_04 E. MIYOSHI	FAR-2117 SERIES	TITLE	CU-200
CHECKED	TAKAHASHI, T	MODEL 1833C	名称	防水型カードインターフェイス(埋込装備)
APPROVED	Y. Hatai	MODEL 1833C-BB	外寸図	
SCALE	1/3	#100	NAME	MEMORY CARD INTERFACE UNIT (FLUSH MOUNT)
DWG.No.	C3532-004-B	19-023-300G-1		OUTLINE DRAWING



表 1 TABLE 1

寸法区分 (mm) DIMENSIONS	公差 (mm) TOLERANCE
L ≤ 50	±1.5
50 < L ≤ 100	±2.5
100 < L ≤ 500	±3



矢視 A  
VIEW A

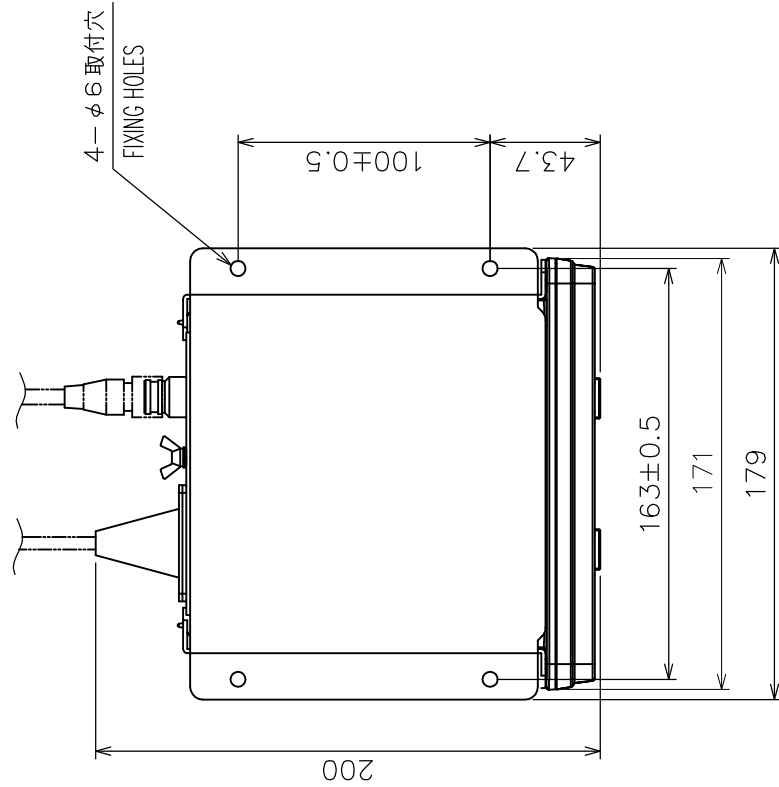
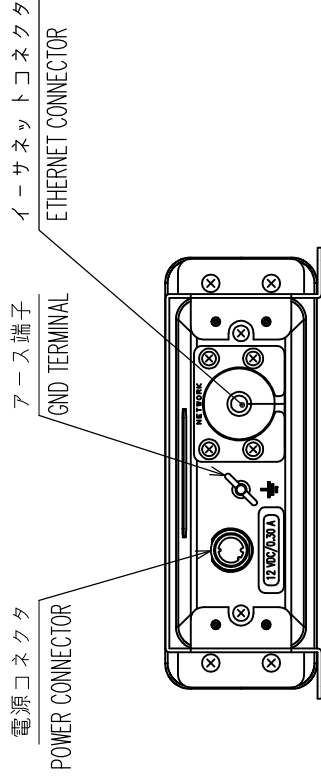
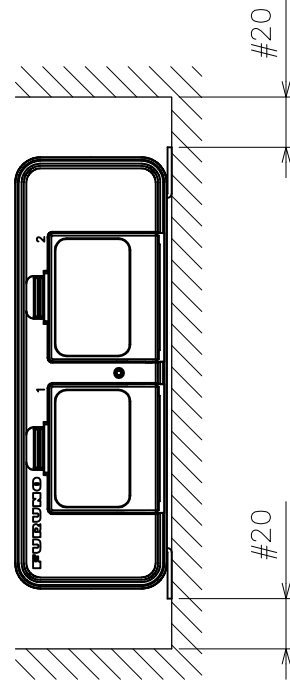
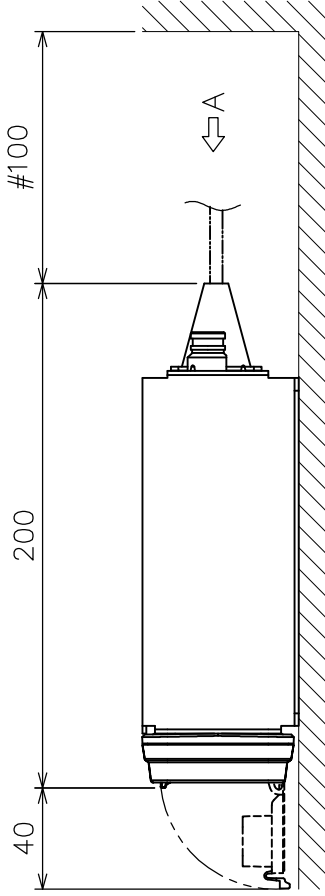

- 注 記
- # 印寸法は最小サービス空間寸法とする。
  - 指定外の寸法公差は表 1 による。
  - 取付用ネジは + トラスタップピンネジ呼び径 5 × 2.0 を使用のこと。
- NOTE
- # MINIMUM SERVICE CLEARANCE.
  - TABLE 1 INDICATES TOLERANCE OF DIMENSIONS WHICH IS NOT SPECIFIED.
  - USE SELF-TAPPING SCREWS 5X2.0 FOR FIXING THE UNIT.

DRAWN	MOR. 29.04 E. MIYOSHI	FAR-2117 SERIES	TITLE	CU-200
CHECKED	TAKAHASHI, T	MODEL 1833C	名称	防水型カードインターフェイス(卓上装備)
APPROVED	Y. Hotoi	MODEL 1833C-BB		外寸図
SCALE	1/3	1.3 kg	NAME	MEMORY CARD INTERFACE UNIT (TABLETOP MOUNT)
DWG.No.	C3532-605-B	19-023-310C-1		OUTLINE DRAWING



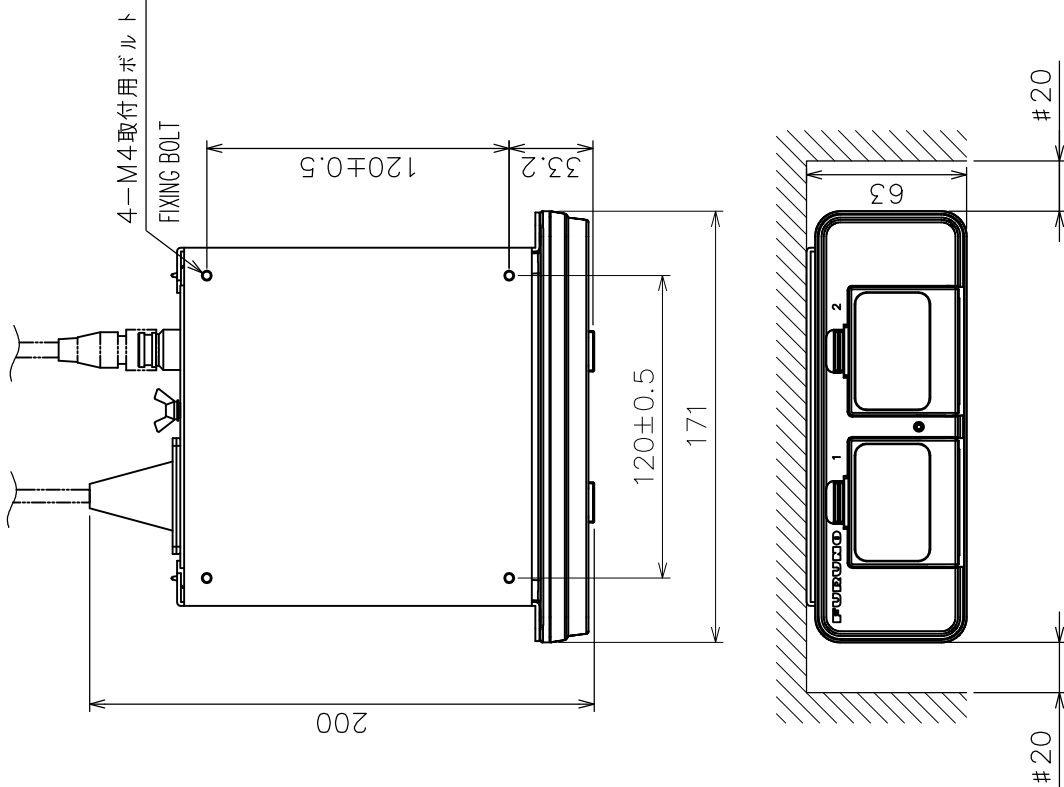

**注 記**

- 1) #印寸法は最小サービス空間寸法とする。
- 2) 指定外の寸法公差は表1による。
- 3) 取付用ナットはM4ナットを使用のこと。
- 4) 取付板厚は最大8mmとする。

**NOTE**

1. # MINIMUM SERVICE CLEARANCE.
2. TABLE 1 INDICATES TOLERANCE OF DIMENSIONS WHICH IS NOT SPECIFIED.
3. USE NUT M4 FOR FIXING THE UNIT.
4. MAX. MOUNTING BASE THICKNESS IS 8 MM.



表 1 TABLE 1

寸法区分 (mm) DIMENSIONS	公差 (mm) TOLERANCE
L ≤ 50	± 1.5
50 < L ≤ 100	± 2.5
100 < L ≤ 500	± 3



DRAWN	Mr. 29_04 E. MIYOSHI	FAR-2117 SERIES	TITLE	CU-200
CHECKED	TAKAHASHI, T	MODEL 1833C	名 称	防水型カードインターフェイス(天井装備)
APPROVED	Y. Hatatai	MODEL 1833C-BB	外寸図	
SCALE	1/3	WMS 1.3	NAME	MEMORY CARD INTERFACE UNIT (OVERHEAD MOUNT)
DWG.No.	C3532-G06-B	19-023-320G-1		OUTLINE DRAWING

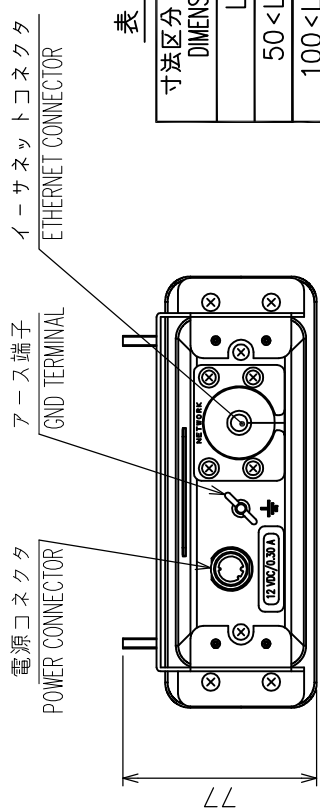
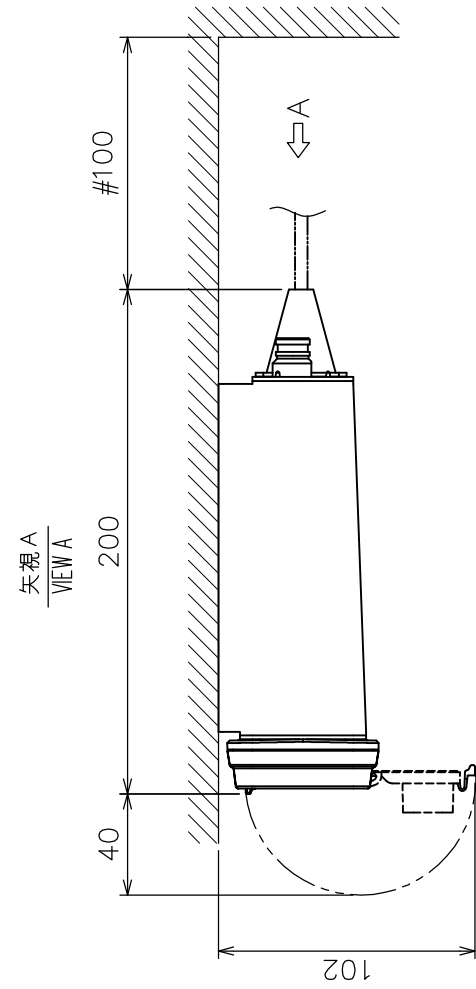

表 1 TABLE 1

寸法区分 (mm) DIMENSIONS (mm)	公差 (mm) TOLERANCE (mm)
L ≤ 50	± 1.5
50 < L ≤ 100	± 2.5
100 < L ≤ 500	± 3
500 < L ≤ 1000	± 4

矢視 A  
VIEW A

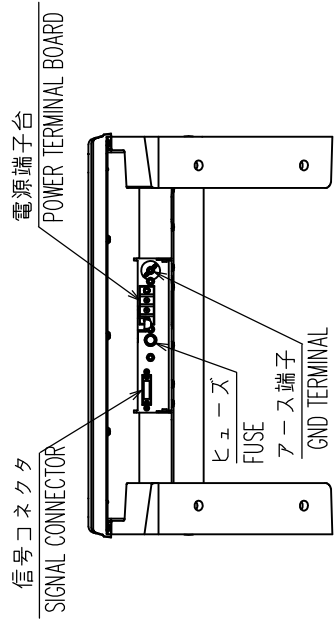
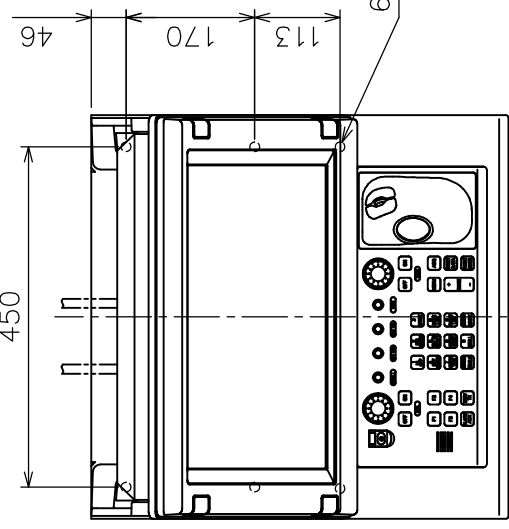
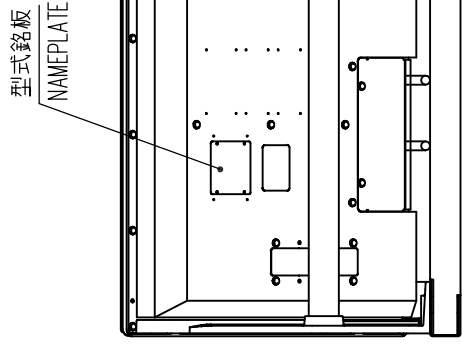
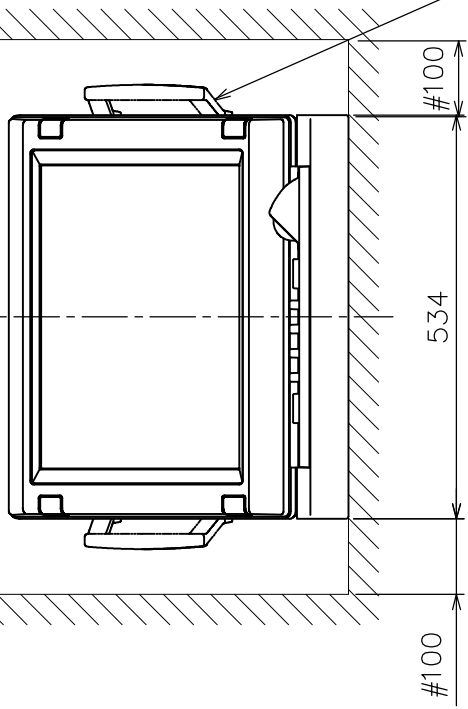
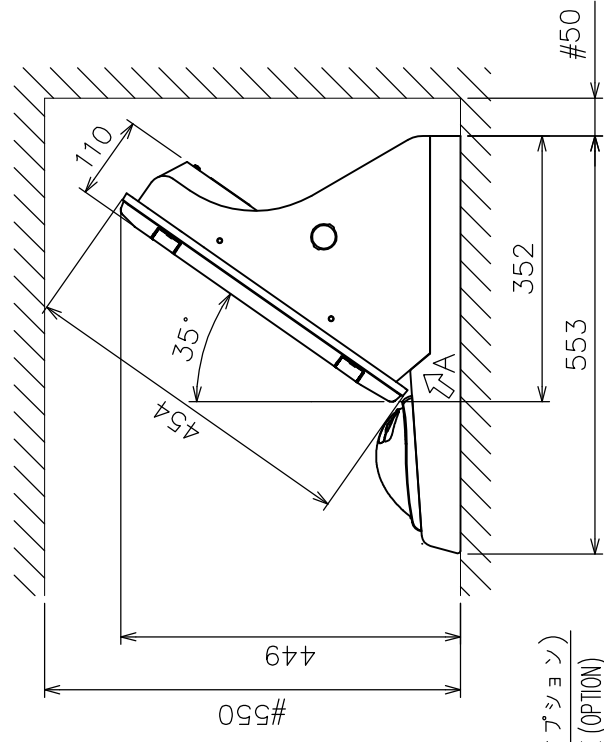

- 注 記
- 1) # 印寸法は最小サービスクリアランスとする。
  - 2) 指定外の寸法公差は表 1 による。
  - 3) 取付用ネジは M10 ボルト、またはコーチボルト呼び径 9 を使用のこと。
  - 4) 質量は操作部ケーブ (10m) を含む。
- NOTE
1. # MINIMUM SERVICE CLEARANCE.
  2. TABLE 1 INDICATES TOLERANCE OF DIMENSIONS WHICH IS NOT SPECIFIED.
  3. USE M10 BOLTS OR COACH SCREWS φ9 FOR FIXING THE UNIT.
  4. MASS INCLUDES CONTROL CABLE (10m).

DRAWN Mar. 18 '04	E. MIYOSHI	TITLE	MU-201CR w/ RCU-014
CHECKED	TAKAHASHI, T	名称	指示部 (連結タイプ)
APPROVED	Y. Hotoi	外寸図	
SCALE	1/1.0	NAME	DISPLAY UNIT (COMBINATION TYPE)
DWG. No.	C3519-G27-A		OUTLINE DRAWING



表 1 TABLE 1

寸法区分 (mm) DIMENSIONS (mm)	公差 (mm) TOLERANCE (mm)
L ≤ 50	± 1.5
50 < L ≤ 100	± 2.5
100 < L ≤ 500	± 3
500 < L ≤ 1000	± 4



型式銘板  
NAMEPLATE

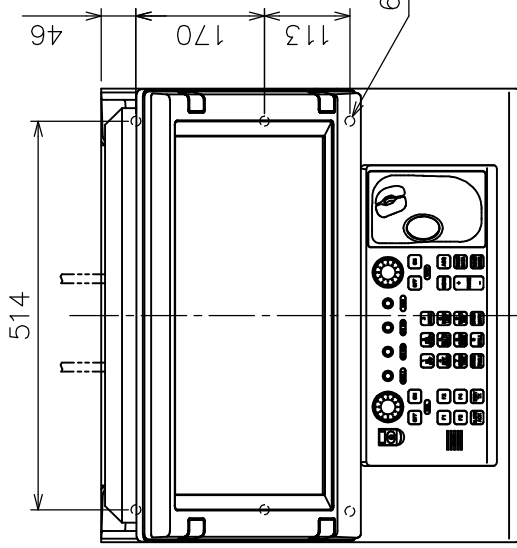
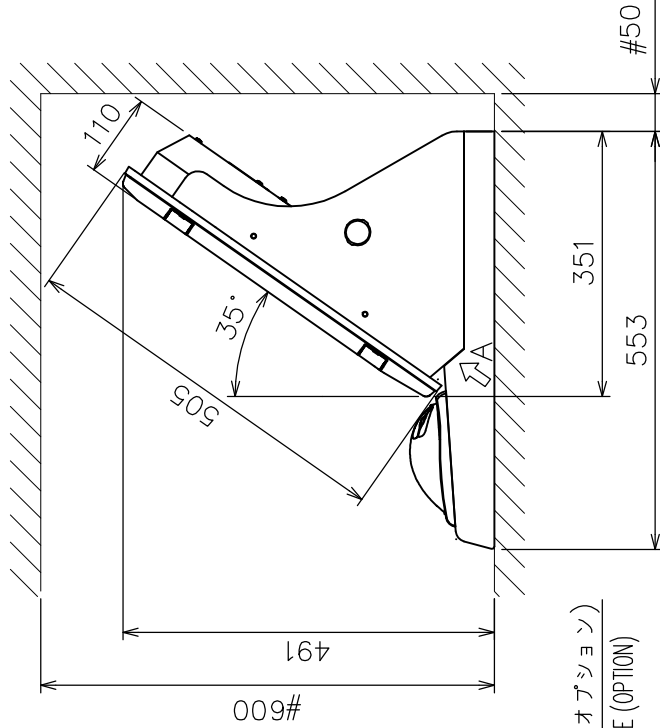
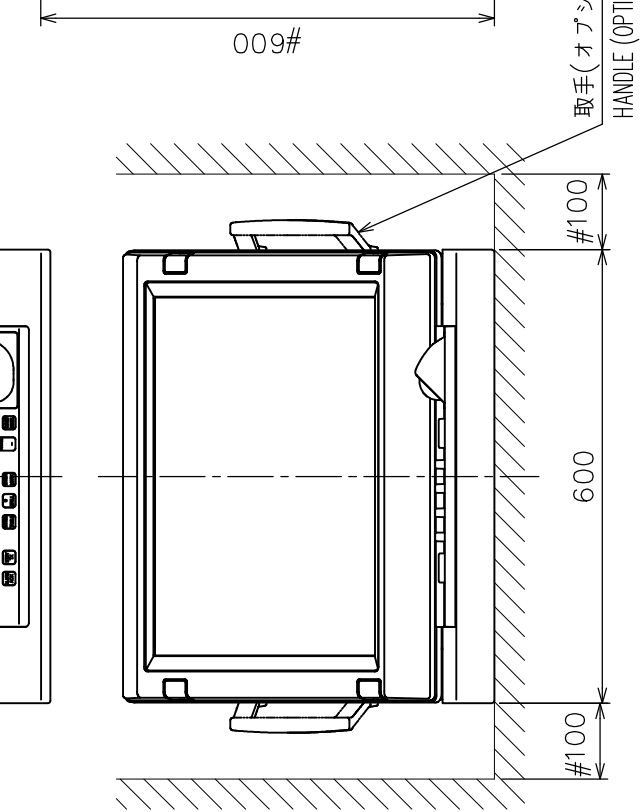
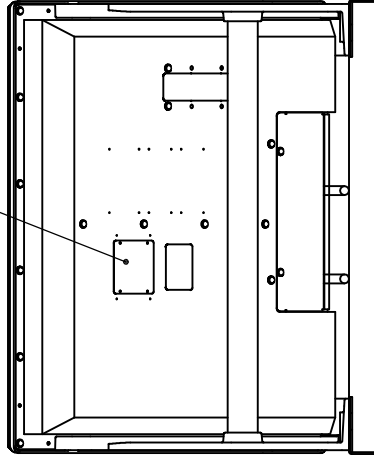

注 記 1) #印寸法は最小サービス空間寸法とする。

2) 指定外の寸法公差は表 1 による。

3) 取付用ネジは M10 ボルト、またはコーチボルト呼び径 9 を使用のこと。

4) 質量は操作部ケーシング (10mm) を含む。

NOTE 1. # MINIMUM SERVICE CLEARANCE.

2. TABLE 1 INDICATES TOLERANCE OF DIMENSIONS WHICH IS NOT SPECIFIED.

3. USE M10 BOLTS OR COACH SCREWS φ9 FOR FIXING THE UNIT.

4. MASS INCLUDES CONTROL CABLE (10mm).

DRAWN Mor.18.04	E. MIYOSHI	TITLE MU-231CR w/RCU-014
CHECKED TAKAHASHI, T	Y. Hatohi	名称 指示部 (連結タイプ)
APPROVED Y. Hatohi	FAR-2807	外寸図
SCALE 1/1.0	33 kg	NAME DISPLAY UNIT (COMBINATION TYPE)
DWG No. C3524-607-A	03-163-761G-2	OUTLINE DRAWING

表 1 TABLE 1

寸法区分 (mm) DIMENSIONS	公差 (mm) TOLERANCE
$L \leq 50$	$\pm 1.5$
$50 < L \leq 100$	$\pm 2.5$
$100 < L \leq 500$	$\pm 3$

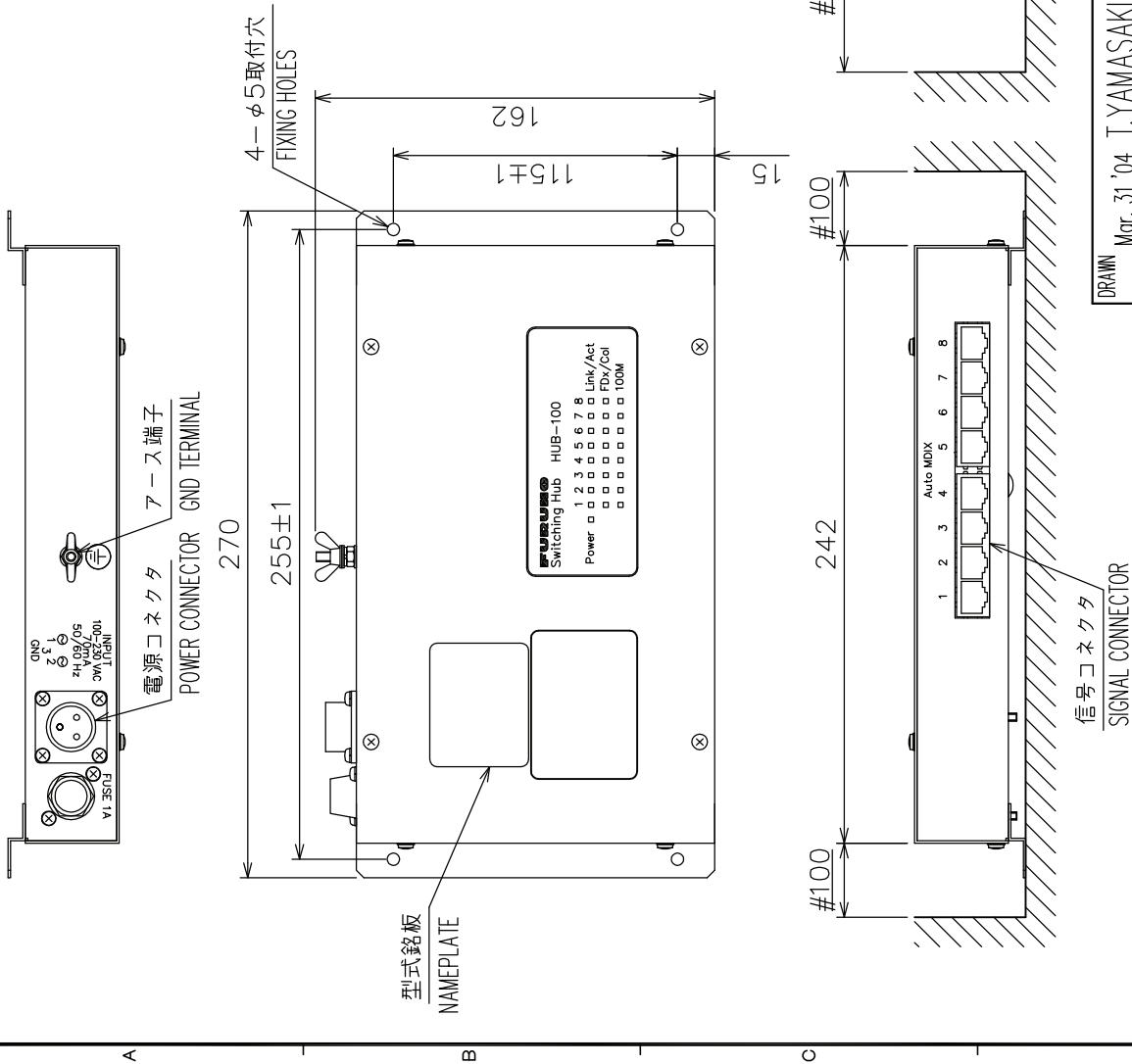

注 記

- 1) 取付ネジはトラスタップネジ呼び径4×16を使用のこと
- 2) 指定外寸法公差は表1による
- 3) #印寸法は最小サービス空間寸法とする

NOTE

1. USE TAPPING SCREWS 4x16 FOR FIXING THE UNIT.
2. TABLE 1 INDICATES TOLERANCE OF DIMENSIONS WHICH IS NOT SPECIFIED.
3. # MINIMUM SERVICE CLEARANCE.

DRAWN	Mar. 31 '04	T. YAMASAKI	TITLE	HUB-100
CHECKED	Mar. 31 '04	T. MATSUGUCHI	名称	イーサネットスイッチングハブ
APPROVED	Apr. 05 '04	Matsuguchi	外寸図	
SCALE	1/3	MASS 1.5 ±10% kg	NAME	SWITCHING HUB
DWG.No.	C3519-G18-B			OUTLINE DRAWING

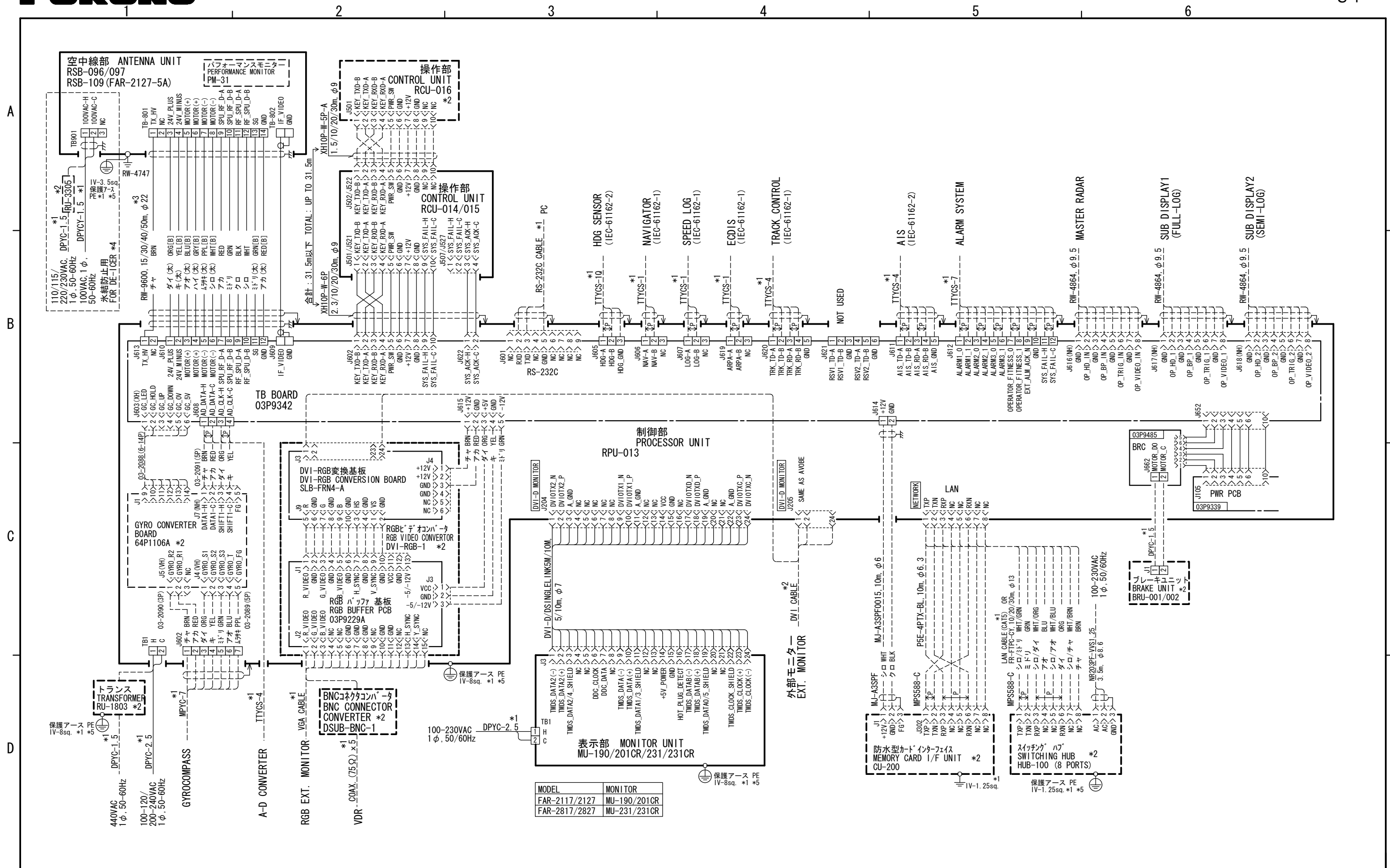

注記  
 \*1: 造船所手配  
 \*2: オプション  
 \*3: 最長 100m (延長するときは接続箱RJB-001が必要)  
 \*4: 船内配電盤では3Aのブレーカを使用。  
 \*5: 保護アース用ケーブルは緑/黄の絶縁線を使用のこと。

NOTES  
 \*1: SHIPYARD SUPPLY  
 \*2: OPTION  
 \*3: MAX. 100m (JUNCTION BOX RJB-001 IS REQUIRED FOR EXTENSION)  
 \*4: USE 3A BREAKER IN SHIP'S MAINS SWITCH BOX.  
 \*5: USE GRN/YEL WIRE FOR PROTECTIVE EARTH.

MODEL	MONITOR
FAR-2117/2127	MU-190/201CR
FAR-2817/2827	MU-231/231CR

DRAWN	9/AUG/2010 T. YAMASAKI	TYPE	FAR-2117/2127/2817/2827 (AC SET)
CHECKED	9/AUG/2010 T. TAKAHASHI	名称	船舶用レーダー/ARPA
APPROVED	10/AUG/2010 Y. NISHIYAMA		相互接続図
SCALE	MASS kg	NAME	MARINE RADAR/ARPA
DWG. No.	C3519-C01- T	REF. No.	03-163-6001-7
INTERCONNECTION DIAGRAM			

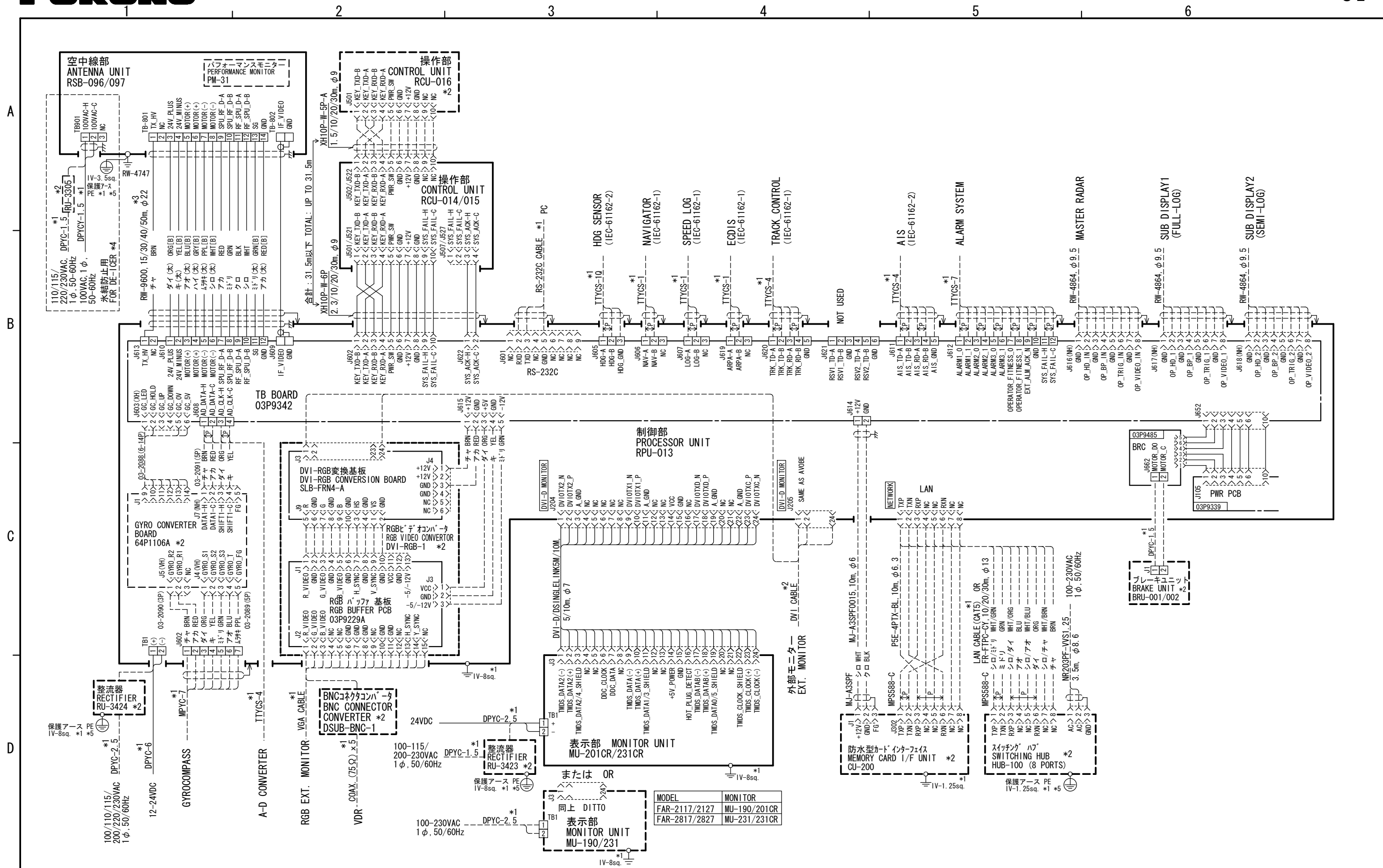

注記  
 \*1: 造船所手配。  
 \*2: オプション。  
 \*3: 最長 100m (延長するときは接続箱RJB-001が必要)。  
 \*4: 船内配電盤では3Aのブレーカを使用。  
 \*5: 保護アース用ケーブルは緑/黄の絶縁線を使用のこと。

NOTES  
 \*1: SHIPYARD SUPPLY.  
 \*2: OPTION.  
 \*3: MAX. 100m. (JUNCTION BOX RJB-001 IS REQUIRED FOR EXTENSION)  
 \*4: USE 3A BREAKER IN SHIP'S MAINS SWITCH BOX.  
 \*5: USE GRN/YEL WIRE FOR PROTECTIVE EARTH.

DRAWN	20/AUG/2010 T. YAMASAKI	TYPE	FAR-2117/2127/2817/2827 (DC SET)
CHECKED	20/AUG/2010 T. TAKAHASHI	名称	船舶用レーダー/ARPA
APPROVED	23/AUG/2010 Y. NISHIYAMA		相互接続図
SCALE	MASS kg	NAME	MARINE RADAR/ARPA
DWG. No.	C3519-C02-S	REF. No.	03-163-6001-7
INTERCONNECTION DIAGRAM			

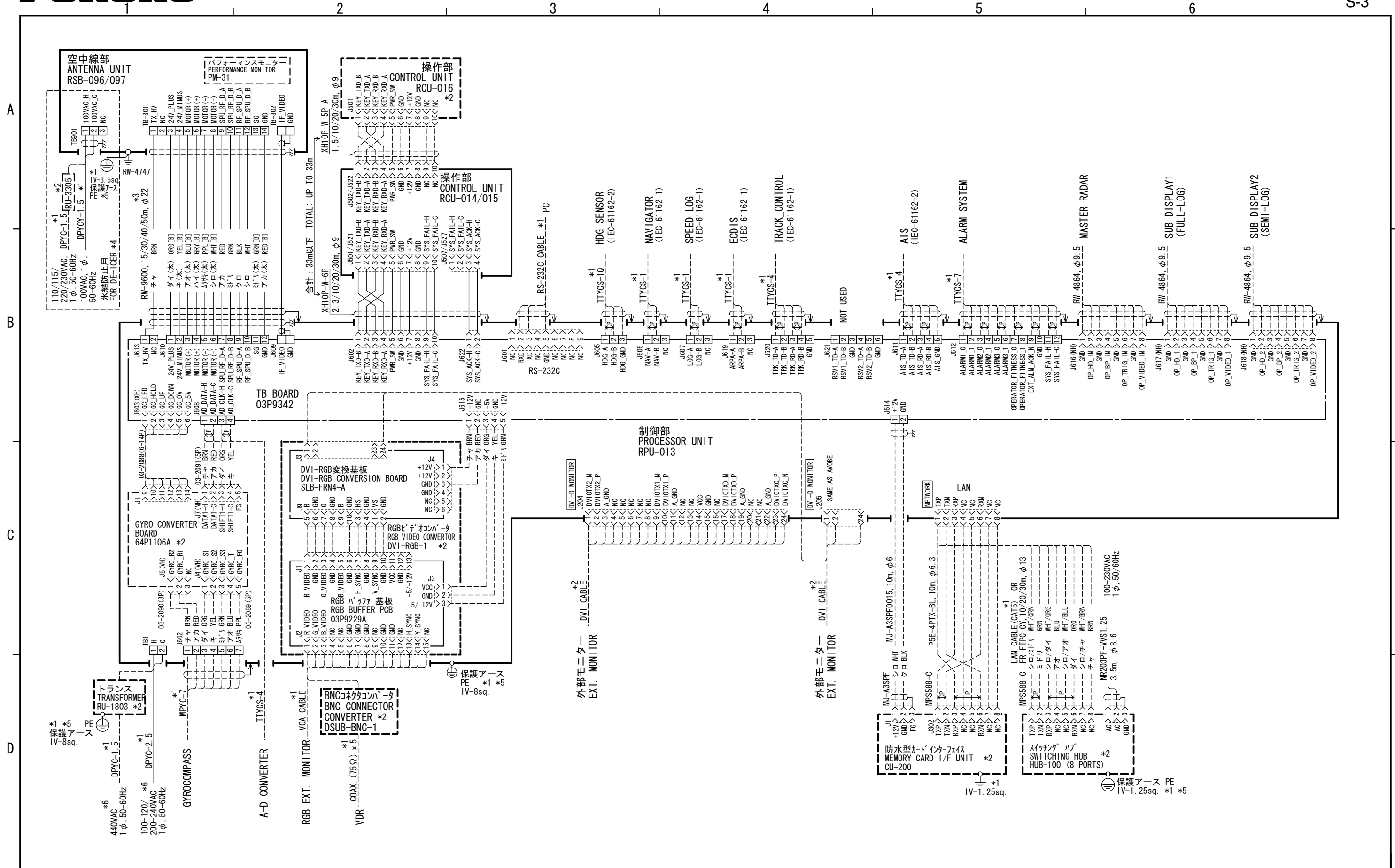

注記  
 \*1 : 造船所手配。  
 \*2 : オプション。  
 \*3 : 最長 100m (延長するときは接続箱RJB-001が必要)。  
 \*4 : 船内配電盤では3Aのブレーカを使用。  
 \*5 : 保護アース用ケーブルは緑/黄の絶縁線を使用のこと。  
 \*6 : 交流は両極切りブレーカ (造船所手配) を経由すること。

NOTES  
 \*1 : SHIPYARD SUPPLY.  
 \*2 : OPTION.  
 \*3 : MAX. 100m. (JUNCTION BOX RJB-001 IS REQUIRED FOR EXTENSION)  
 \*4 : USE 3A BREAKER IN SHIP'S MAINS SWITCH BOX.  
 \*5 : USE GRN/YEL WIRE FOR PROTECTIVE EARTH.  
 \*6 : PASS THE AC LINE THROUGH A DOUBLE-CONTACT BREAKER (SHIPYARD SUPPLY).

DRAWN Jun. 26 '06 E. MIYOSHI	TYPE FAR-2117/2127-BB (AC SET)
CHECKED TAKAHASHI.T	名称 船舶用レーダー/ARPA
APPROVED Y. Hatai	相互結線図
SCALE MASS kg	NAME MARINE RADAR/ARPA
DWG. No. C3519-C03-N 03-163-6001-6	INTERCONNECTION DIAGRAM

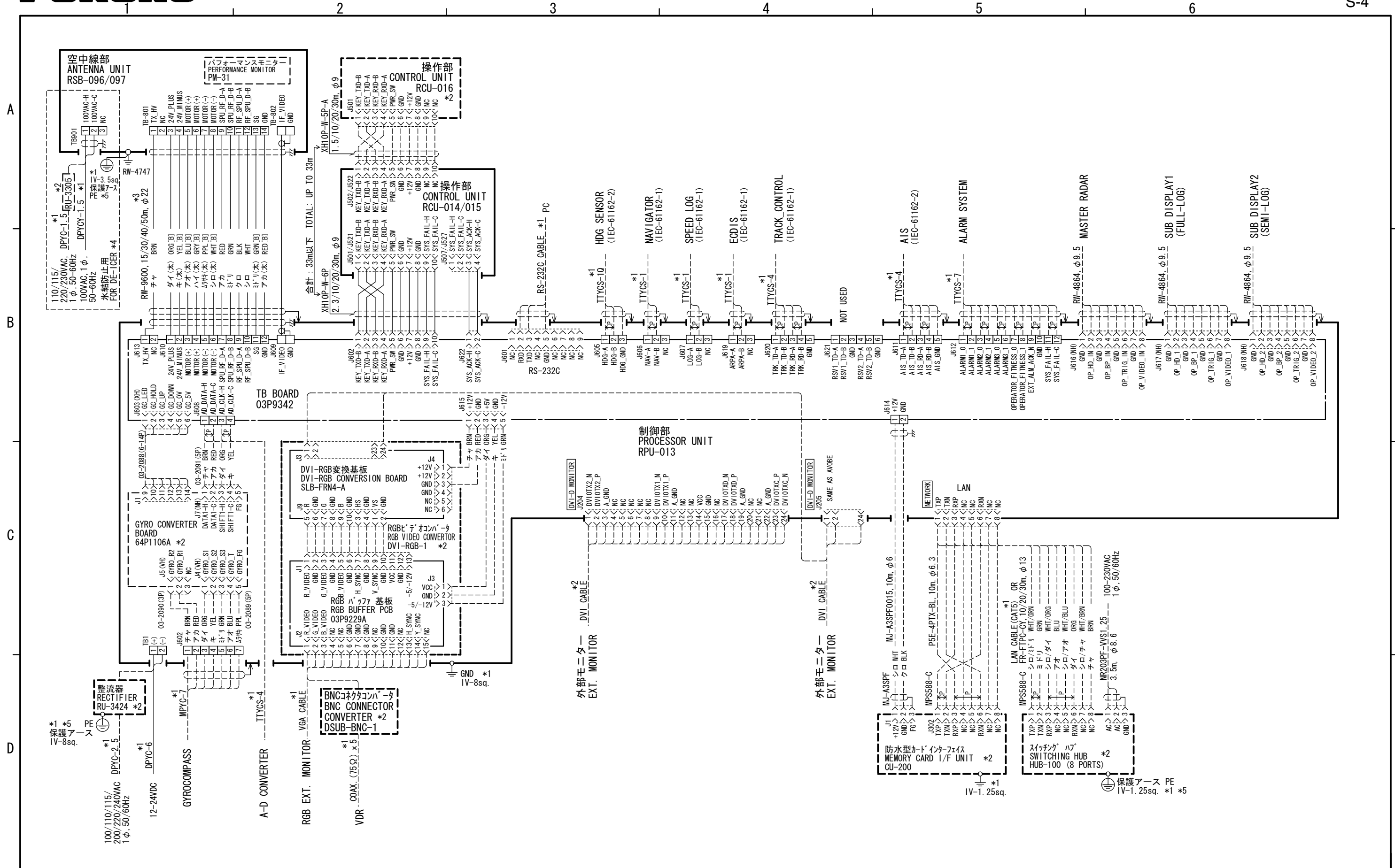

注記  
 \*1: 造船所手配。  
 \*2: オプション。  
 \*3: 最長 100m (延長するときは接続箱RJB-001が必要)。  
 \*4: 船内配電盤では3Aのブレーカを使用。  
 \*5: 保護アース用ケーブルは緑/黄の絶縁線を使用のこと。

NOTES  
 \*1: SHIPYARD SUPPLY.  
 \*2: OPTION.  
 \*3: MAX. 100m. (JUNCTION BOX RJB-001 IS REQUIRED FOR EXTENSION)  
 \*4: USE 3A BREAKER IN SHIP'S MAINS SWITCH BOX.  
 \*5: USE GRN/YEL WIRE FOR PROTECTIVE EARTH.

DRAWN Jun. 26 '06 E. MIYOSHI	TYPE FAR-2117/2127-BB (DC SET)
CHECKED TAKAHASHI.T	名称 船舶用レーダー/ARPA
APPROVED Y. Hatai	相互結線図
SCALE MASS kg	NAME MARINE RADAR/ARPA
DWG. No. C3519-C04-M 03-163-6001-6	INTERCONNECTION DIAGRAM