

REMINGTON®

POWERHAMMER Model 476

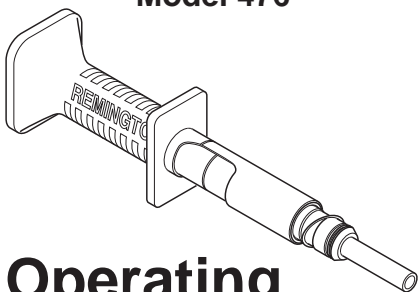

Operating Instructions

The Remington Powerhammer is designed for use with Remington Powder 22 caliber, Type A crimped loads and Remington Power Fasteners which are no longer than 63.5mm (2 1/2"). Remington Power Fasteners are manufactured from special steel and heat treated to produce a very hard, yet ductile, fastener.

CAUTION:

Always use Remington 22 caliber Type A crimped loads or loads manufactured to specifications outlined in the P.A.T.M.I. "Technical Data Pertaining to Powder Loads (Boosters)", latest revision. Use of loads other than those conforming to these specifications may cause load-ejection problems or damage the tool.

Read this manual and all labels carefully before operating your powder actuated tool. This manual should always accompany the tool and be transferred with it upon change of ownership.

 **WARNING:** This tool is designed only for use by qualified operators. Qualification is obtained through a thorough understanding of the *Safety Warnings* and operating instructions as defined in this operating manual.

WARNING:

Safety Precautions

The following pages contain detailed warnings, cautions, and rules of safe operation. Read carefully and become familiar before operating to avoid serious injury. We expressly disclaim any liability for any injury to persons or damage to property which result from your failure to take the precautions contained in this manual.

BEFORE USING

1. **ALWAYS** handle the tool as if it were loaded. Before starting work, check that the tool is unloaded and the muzzle is clear. **NEVER** load a tool unless it is going to be used.

2. **ALWAYS** inspect to make sure the tool is working properly. If the tool does not work properly or is damaged remove from service and tag **DEFECTIVE**.

3. Operators and bystanders must **ALWAYS** wear goggles and ear protection that meet or exceed CE standards.

4. **ALWAYS** clear the work area on all sides and post appropriate warning signs on job sites.

Safety Precautions

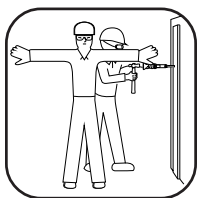
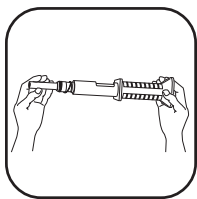

Safety Precautions

HANDLING THE TOOL

1. **NEVER** place your hand over the muzzle. Accidental discharge can cause serious injury.

2. **ALWAYS** store **UNLOADED** powder actuated tool and loads in a locked container. Keep powder loads of different power levels in separate containers.

3. **NEVER** carry or pass a loaded powder actuated tool. **NEVER** point a powder actuated tool at anyone.

4. **ALWAYS** take precautions to maintain your balance while operating a powder actuated tool.

5. An operator taking medication should take extra precautions while handling the tool. **NEVER** drink alcoholic beverages or take medications which impair your vision, balance or judgement before using a powder actuated tool.

Safety Precautions

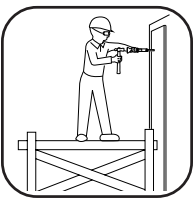
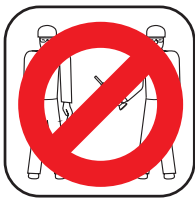

Safety Precautions

KNOW YOUR FASTENING BASE MATERIAL

1. **ALWAYS** know the thickness and type of base material into which you are fastening. **NEVER GUESS.** Test the base material by using the Center Punch Test. The Center Punch Test is performed by using a hammer to test drive the particular fastener to be used into the material. If the point penetrates easily, the material is too soft. If the point becomes blunt, the material is too hard. If the material fractures, cracks or shatters, the material is too brittle. Test fastenings should always be made starting with the lowest power load (Gray-Level 1) and proceeding with the order shown. Operators and bystanders must **ALWAYS** wear goggles and ear protection that meet or exceed CE standards.

2. **NEVER** attempt to drive fasteners into very hard or brittle materials including, but not limited to cast iron, glass, tile, stone, brick, or hardened steel. Materials of this type tend to shatter and create hazard from flying particles.

3. **NEVER** make fastenings in spalled or cracked areas.

Safety Precautions

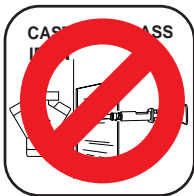
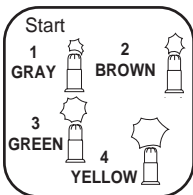
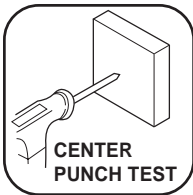

Safety Precautions

4. **NEVER** drive fasteners into thin or easily penetrated materials unless it is backed by concrete or steel. When in doubt, such as when base material is concealed, conduct a Center Punch Test. Check continually to avoid fastening into unsuitable material, especially in older buildings.

5. **DO NOT** fasten thru or within 13mm (1/2") of predrilled or pre-punched holes.

6. **DO NOT** drive fasteners into concrete less than three times as thick as the intended fastener penetration, within 76mm (3") of the edge, within 76mm (3") of another fastener or within 76mm (3") of a failed fastener.

7. **DO NOT** drive fasteners into steel base material less than 5mm (3/16") thick, within 51mm (2") of a weld, within 13mm (1/2") of the edge or within 25mm (1") of another fastener.

8. When fastening into masonry walls, always drive into horizontal mortar joints, **NEVER** into vertical mortar joints. **BE CAREFUL**, a poorly laid joint may permit too much penetration, and/or unsatisfactory holding power.

Safety Precautions

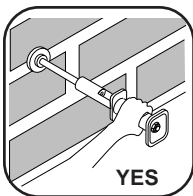
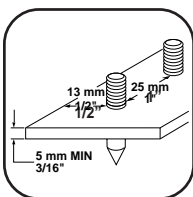
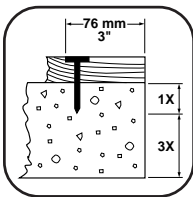
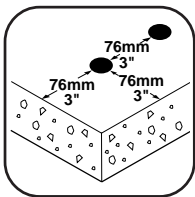
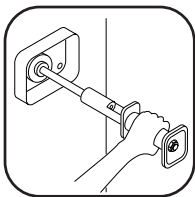
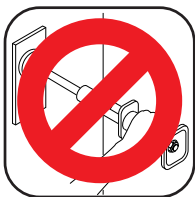

Safety Precautions

OPERATING THE TOOL

1. **ALWAYS** hold tool perpendicular to work surface.

2. Should the tool fail to fire, hold the muzzle firmly against the work surface for 30 seconds. Then remove the tool, eject the load and safely discard the misfired load into water or oil.

3. **ALWAYS** use the spall shield when driving directly into concrete or steel. **ALWAYS** wear goggles.

4. **NEVER** use a powder actuated tool in an explosive or flammable atmosphere or when non sparking tools are required.

POWDER LOADS AND FASTENERS

1. **NEVER** leave unfired powder loads on floors or work surfaces.

Safety Precautions

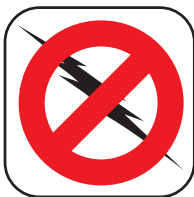
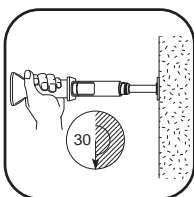
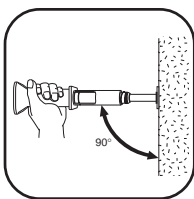

Safety Precautions

2. Remington Powder Loads are available in four power levels with gray (1) being the lowest power level and yellow (4) being the highest power level. Always start with the lowest power level (gray-level 1) and increase until a proper fastening is made. Always use Remington powder loads or loads manufactured to specifications outlined in the P.A.T.M.I. "Technical Data Pertaining to Powder Loads (Boosters)".

3. **NEVER** use powder loads in firearms.

4. **NEVER** carry fasteners or other hard objects in the same pocket or container with powder loads.

5. A color blind person must take extra precautions to prevent the chance of mixing the powder loads of various levels.

6. Fasteners are a permanently installed fixture. An act of demolition is required for their removal. Appropriate safety precautions must be taken.

Safety Precautions

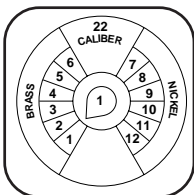
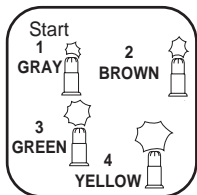

NOTE: Failure to start with the lowest power level can result in overdrive condition and will result in damage to tool.

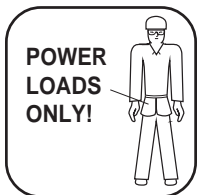

Safety Precautions

7. **NEVER** use fasteners longer than 63.5mm (2 1/2"). **NEVER** use common nails. Remington Power Fasteners are manufactured from special steel and heat treated to produce a very hard, yet ductile fastener.
-

8. **NEVER** pry a load out of the chamber. Prying can discharge the load causing serious injury.
-

9. **ALWAYS** insert the fastener first, then the powder load. If work is interrupted for any reason, **ALWAYS** remove the powder load before removing the fastener.

Why A Fastener Holds

CONCRETE:

As a general rule, penetration should be approximately 25mm to 32mm (1" to 1 1/4") into the base concrete. Make sure the concrete is at least three times as thick as the intended fastener penetration. Never have the fastener point protrude thru the concrete.

NOTE: Concrete needs to cure for 28 days before maximum fastening holding power will be achieved.

STEEL:

In steel, the point of the fastener must penetrate completely through for highest holding power. If not, the spring action of the steel pushes back on the point and tends to force the fastener out.

Recommended application are between 5mm to 8mm (3/16-5/16") steel.

Safety Precautions

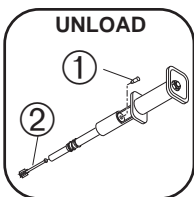
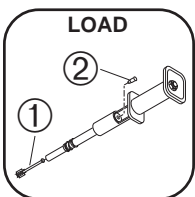
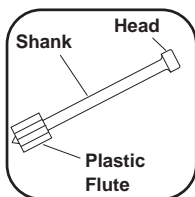

Overdriven Fasteners

An overdriven fastener results when too strong of a powder load is used causing the piston to extend past the muzzle. Move to the next lightest powder load. Repeated overdrive will damage your tool. By avoiding overdrive, you can extend the life of your tool considerably.

NOTE: NEVER fire the tool without a fastener. This can damage the tool and/or cause possible injury to the operator.

IMPORTANT: If the tool does not open after firing and the piston is overdriven, see *Piston Overdrive*, page 18.

Operation

LOADING THE POWERHAMMER

1. Insert the proper fastener into the muzzle, round metal head first. Push fastener until the point is even with the end of the muzzle.
2. Grab the muzzle and pull forward until it stops. This sets the piston and opens the chamber area.
3. Insert the proper Remington Powder Load into the chamber, while holding the muzzle downward. Be sure to keep holding the muzzle downward and away from you. The powder load will not seat fully.
4. Push the barrel into the housing until it stops and hold in the closed position keeping the muzzle pointed down. This keeps the powder load from falling out of the chamber.

FIRING THE POWERHAMMER

1. Place the muzzle of the tool against the work surface, hold at 90°, **Do Not Tilt.**
2. Hold the grip with one hand and push down, compressing the spring. The groove around the barrel and outside of the housing at the chamber area **MUST** line up (as shown) for the tool to operate properly. If the grooves **DO NOT** line up, check that the powder load has not fallen out of the chamber.
3. **ALWAYS** keep the chamber opening away from the wrist to avoid contact from escaping gas.
4. Using a one pound hammer, **HIT THE FIRING PIN SQUARELY WITH A SHARP, STRONG BLOW.** Hold the hammer as close as you can to the tool head to improve your accuracy. For best results, work at a level below shoulder height.
5. If the powder load does not fire with the first blow, wait 30 seconds, eject the powder load and start over again. **NOTE: A LIGHT HAMMER BLOW WILL JAR THE DRIVE PISTON OUT OF PROPER POSITION CAUSING LESS POWER AND PENETRATION OF THE FASTENER.**

Operation

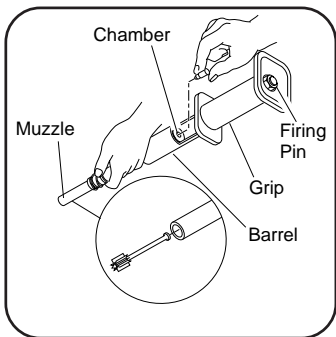

LOADING

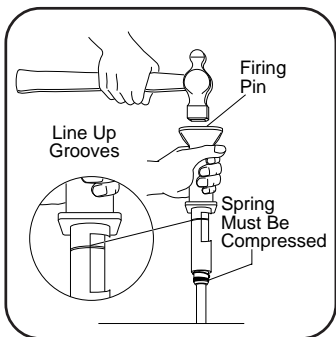

FIRING

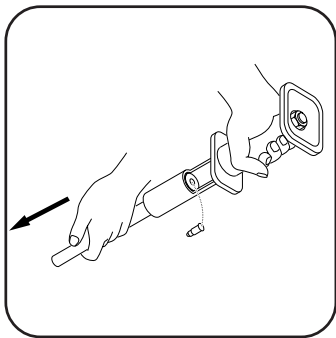

EJECTING

Continued

Operation

6. After the fastening is made, remove the tool from the work surface. Grab the barrel and pull forward rapidly. This ejects the spent load and sets the piston in the firing position.
7. **NOTE: THE TOOL CANNOT BE FIRED IN THE OVERHEAD POSITION.**

PISTON OVERDRIVE

If the tool does not open after firing and the piston is 13mm (1/2"), or more out of the muzzle:

1. Place the muzzle end of the tool against wooden work surface and hold grip with one hand.
2. Hit the firing pin with a hard hammer blow several times and force piston back into muzzle.
3. Eject the powder load. (See step 6 of *Firing The Powerhammer*).

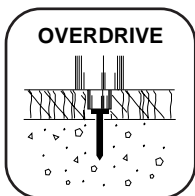

CARE OF YOUR POWERHAMMER

Clean your Powerhammer after each day's use. Clean chamber with accessory wire brush, part number 56485. Apply good quality penetrating lubricant spray (such as WD-40) sparingly and wipe dry.

NOTE: The labor regulations of many counties require that the operator of this tool on a job site be thoroughly trained and certified for competence prior to operating this tool.

Limited Warranty

DESA International warrants this Remington Model 476 POWERHAMMER against defects in materials and workmanship for a period of 30 days from the date of purchase. This warranty extends only to the original purchaser of the POWERHAMMER and only applies if the POWERHAMMER is used for normal household (non-commercial or non-professional) purposes.

If within 30 days from the purchase date this POWERHAMMER fails due to a defect in material or workmanship, DESA will repair or replace the tool at DESA's option. However, this warranty does not cover failures caused by misusing or abusing the product (for proper use of this product, read and understand the operating instructions in this owner's manual). In order to obtain service under this warranty, the purchaser must return the POWERHAMMER with proof of purchase.

If inspection shows the repairs required were caused by defective material or workmanship, DESA will repair or replace the tool without charge. Repairs made necessary because of misuse, abuse, negligence or accident will be charged for at regular repair prices.

This express and limited warranty is the only warranty on this product, and there are no warranties, including warranties of merchantability and/or fitness for a particular purpose, express or implied, which extend beyond this express and limited warranty.

In no event will the liability of DESA for economic injury, property damage or any other damages whatsoever, including consequential and incidental damages, arising from the sale or use of this product exceed the purchase price of this product.

Some countries do not allow a limitation on how long an implied warranty lasts, or an exclusion or limitation of incidental or consequential damages, so the above limitation of implied warranties, or exclusion or limitation on damages may not apply to you.

This warranty gives you specific legal rights, and you may also have other rights which vary from country to country.

For information about this warranty contact:

DESA EUROPE
Post Bus 11158
3004 ED Rotterdam
The Netherlands
Attn: Sales Department
Tel: (31) 10-4376666
Fax: (31) 10-4150910

NOTICE:

This is your Owner's Manual.
Read Carefully before
operating your
Remington POWERHAMMER

Accessories

Part No.	Description
56485	Brush, .25
101849-01	Goggles
TA4090	Shield, Spall

IMPORTANT

This tool is designed to use Remington 22 caliber neck-down crimped loads, power levels 1 (gray) through 4 (yellow).

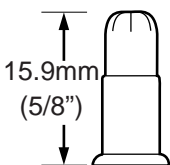

Neck-Down
Crimped Power
Load



Straight Wadded
Power Load



CAUTION

Do not use any load other than the Remington 22 caliber neck-down crimped powder load. Other types of powder loads will cause load-ejection problems.

DESA EUROPE
Post Bus 11158
3004 ED Rotterdam
The Netherlands
Attn: Sales Department
Tel: (31) 10-4376666
Fax: (31) 10-4150910