



## INSTALLATION MANUAL FOR KYOCERA PV MODULES

**KD315GX-LFB, KD320GX-LFB**

Please read this manual carefully before installing the modules.

6C-210816

### 1. INTRODUCTION

As the world leader in the development and application of high technology ceramic/silica materials, Kyocera offers a wide range of highly efficient and reliable crystalline silicon solar photovoltaic (PV) power modules. Kyocera began to extensively research PV technology in 1975 and commenced manufacturing operations in 1978. Since then, Kyocera has supplied millions of cells and modules throughout the world. With years of experience and state-of-the-art technology, Kyocera provides the highest quality PV power modules in a range of sizes designed to meet the requirements of the most demanding energy users worldwide.

### 2. APPLICATIONS

Kyocera PV module (hereinafter referred to as “the PV module”) is a reliable, virtually maintenance-free direct current (DC) power source, designed to operate at the highest level of efficiency.

The PV module is ideal for residential, commercial, or utility applications; grid-tie or off-grid applications and those with or without using storage batteries.

### 3. WARNINGS & SAFETY

PV modules generate electricity when exposed to light. Arrays of many modules can cause lethal shock and burn hazards. Only authorized and trained personnel should have access to these modules. To reduce the risk of electrical shock or burns, modules may be covered with an opaque material during installation. Do not touch live terminals with bare hands. Use insulated tools for electrical connections. Do not use these modules for solar concentration.

#### PERMIT

- Before installing your PV system, contact local authorities to determine the necessary permits, installation and inspection requirements.

#### INSTALLATION AND OPERATION

- Systems should be installed by qualified personnel only. The system involves electricity, and can be dangerous if the personnel are not familiar with the appropriate safety procedures.
- **Do not step on the module.**
- Although the PV module is quite durable, the glass can be broken if it is dropped or hit by tools or other objects. This will render the PV module inoperable.
- The module frame is made of anodized aluminum, and

therefore corrosion can occur if the module is subject to a salt-water environment and/or is in contact with another type of metal (galvanic corrosion). Pay attention to the above and take appropriate measures to prevent corrosion when selecting the installation environment, material of support structure, and clamping method.

- The PV module frame(s) must be attached to a support structure by one of the methods described in Section 6, INSTALLING PV MODULES.
- Module support structures used to support the PV module(s) should be wind rated and approved by the appropriate local and civil codes prior to installation.
- Do not expose the back of the module to direct sunlight
- In Canada installation shall be in accordance with CSA C22.1, Safety Standard for Electrical Installations, Canadian Electrical Code, Part 1.
- When handling the modules, **DO NOT HOLD THEM BY SUPPORTING ONLY ONE SIDE OF THE FRAME BECAUSE IT CAN CAUSE SEPARATION OF THE GLASS AND FRAME.**
- Do not touch the PV module with bare hands. The frame of the PV module may have sharp edges and may cause injury. Wear suitable gloves, such as leather gloves with padding in the palm and finger areas.

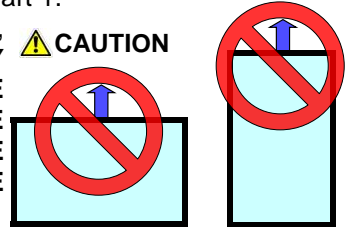

#### FIRE RATING

- In case of roof installation, the PV module assembly shall be mounted on a fire resistant roof covering rated for the application. The PV module is comprised of a glass front surface and polyethylene terephthalate (PET) backsheet and has a Class C fire rating.

#### GROUNDING

- Refer to “Grounding” section.

#### BATTERY

- When PV modules are used to charge batteries, the battery must be installed in a manner which will ensure the performance of the system and the safety of its users. **Follow the battery manufacturer’s safety guidelines concerning installation, operation and maintenance recommendations.** In general, the battery (or battery bank) should be kept away from people and animals. Select a battery site that is protected from sunlight, rain, snow, debris, and is well ventilated. Most batteries generate hydrogen gas when charging which can be explosive. Do not light matches or create sparks near the battery bank. When a battery is installed outdoors, it should be placed in an insulated and ventilated battery case specifically designed for this purpose.

### 4. SITE SELECTION

In most applications, the PV modules should be installed in a location where they will receive maximum sunlight throughout the year. In the Northern Hemisphere, the modules should typically face south, and in the Southern Hemisphere, the modules should typically face north. Modules facing 30 degrees away from true South (or North) will lose approximately 10 to 15 percent of their power output. If the module faces 60 degrees away from true South (or North), the power loss will be 20 to 30 percent.

When choosing a site, avoid trees, buildings or obstructions, which could cast shadows on PV modules especially during the winter season when the arc of the sun is lowest over the horizon.

## 5. MODULE TILT ANGLE

The PV modules produce more power when they are pointed directly at the sun.

For grid-tie installations where the PV modules are attached to a permanent structure, PV modules should be tilted at an angle equal to the site's latitude. This will typically result in the highest annual energy output.

## 6. INSTALLING PV MODULES

A minimum spacing of 2" (50 mm) is required between the PV module and the mounting surface around the perimeter of PV array. The PV modules may be installed in various applications utilizing a variety of support structure options and attachment methods. For optimal performance in all applications, clearance between the module frame and the mounting surface is required to allow cooler ambient air to circulate around the back of the module and to avoid module and/or wiring damage. A minimum of .13" (3.2 mm) spacing must also be maintained between module frames to allow for thermal expansion.

The PV modules may be attached to a support structure by the following methods. The structure should have enough strength to achieve the mounting span. When installing modules in a snowy area, an appropriate countermeasure has to be taken to prevent possible damage to the lower side frame by slipping snow (e.g. attach supporting parts to the lowest modules.). Any damage caused by snow or such countermeasures is not covered under warranty.

**BOLTING:** Use 5/16" (8mm) stainless steel (or equivalent in corrosion resistance) hardware through the existing .35" (9 mm) diameter mounting holes in the module frame and then through the holes on the support structure. Tighten the screws with adequate torque (usually 132 in-lb; refer structure manufacturer specifications). Refer to the module drawings (Section 12) for the position of mounting holes.

**CLAMPING:** Fasten modules firmly using clamps which will not be deformed by wind load or snow load. Clamps should be attached to support structure with 1/4" (6mm) or larger bolt and nut using torque values specified by structure manufacturer. Bolt and nut should be stainless steel or equivalent in corrosion resistance. Support structure should be set perpendicular to the long side of frame, and should support the bottom of module at least 0.39" (10mm) width. Clamps must not bend the module frame nor damage the surface of the frame. Clamps also must not shade the sunlight incidence on glass surface. Take measures to prevent module from falling off clamps. Refer to the 'CLAMPING AREA' in the module drawings (Section 12) for the permissible clamping range.

The clamp specification is below;

A- SUS304 or equivalent

t: thickness	L: width	a: overlap
0.079" (2.0mm) and over	min. 2.76" (70mm)	min. 0.28" (7mm)
0.098" (2.5mm) and over	min. 1.73" (44mm)	
0.12" (3.0mm) and over	min. 1.50" (38mm)	

B-anodized aluminum AL6063-T5 or equivalent

t: thickness	L: width	a: overlap
0.12" (3.0mm) and over	min. 2.28" (58mm)	min. 0.20" (5mm)
0.14" (3.5mm) and over	min. 1.65" (42mm)	
0.16" (4.0mm) and over	min. 1.50" (38mm)	

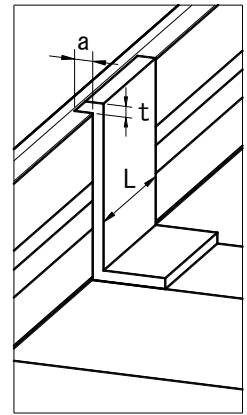

The clamp shape and dimensions above are for reference only, and any damage caused by clamps is not covered under warranty.

## 7. MODULE WIRING

The PV module comes pre-wired. Each module has two #12 AWG type PV-wire stranded sunlight resistant output cables each terminated with R51-7/P51-7 (MC4 compatible). The positive (+) terminal has a male connector while the negative (-) terminal has a female connector. The module wiring is solely for series connections only, i.e. male (+) to female (-) interconnections. Series and/or parallel connections shall be made with #10-14 AWG type PV-wire stranded output cables, having sunlight resistant and temperature rating of 90°C minimum, with R51-7/P51-7 (or MC4: PV-KST4/KBT4).

**NOTE:** When making connections with the connectors, make sure the array is disabled. **DO NOT MAKE CONNECTIONS WHILE UNDER LOAD.** Module output connections are marked "Do not disconnect under load".

**NOTE : MAXIMUM SYSTEM VOLTAGE IS 600 VDC.**

The PV module and most PV system components have a maximum system voltage rating of 600 volts DC. Some grid-tie systems operate at or near this voltage rating. Like other polycrystalline PV modules, the open circuit voltage of the PV modules increases as the ambient temperature decreases. Maximum system voltage is computed as the sum of the open-circuit voltage of the series-connected PV modules for the lowest expected ambient temperature. Refer to the National Electrical Code Article 690-7(A) for determining the maximum number of the PV modules that can be placed in series. Temperature coefficients, specific to the module of use, can be used to provide the most accurate prediction of module voltage under temperature extremes.

**NOTE:** Limit the maximum number of series connections of the PV modules so that the system voltage is 600 V or less.

**NOTE:** Do not connect the modules in parallel without maximum over current protection.

**NOTE:** The minimum radius that the cable can be bent for the PV modules is 1.14" (29mm).

**NOTE:** Under normal conditions, PV modules may produce more current and/or voltage than reported in the standard test conditions. Therefore, when voltage evaluations for components, capacity of conductors, size of fuses, and size of control systems connected to the module output are determined, multiply the values of short-circuit current (Isc)

and open-circuit voltage (Voc) that are marked in the PV modules by the coefficient, 1.25.

**NOTE:** Refer to Section 690-8 of the National Electrical Code for an additional multiplying factor of 125 percent (80 percent derating) which may be applicable.

## 8. GROUNDING

Before installation, consult the local code authorities having jurisdiction to determine the necessary grounding requirements. When installing in the US market, attach all PV module frames to an earth ground in accordance with the National Electrical Code (NEC) Article 250. Proper grounding is achieved by connecting PV module frames and all metallic structural members contiguously to one another using a suitable grounding conductor. The grounding conductor shall be of copper, copper alloy or another material suitable for use as an electrical conductor per NEC. The grounding conductor must then make a connection to earth using a suitable earth grounding electrode. Ensure positive electrical contact through the anodizing on the module frame extrusion by utilizing one of the following methods.

Attach the grounding conductor:

- (1) to one of the .28" (7mm) diameter holes marked "ground" using 1/4" (6mm) stainless steel bolt. Wrap conductor around bolt. Tighten the screws with adequate torque (usually 62 in-lb; refer structure manufacturer specifications).
- (2) to a ground lug (manufacturer: ILSCO, model: GBL-4DBT). The lug is attached to one of the .28"(7mm) diameter holes marked "ground", using #10-32 stainless steel bolt with 40 in-lb torque.

**NOTE:** A stainless steel star washer or mounting washer nut, having contact with anodized surface of the frame, must be employed to break through the anodized layer of the frame extrusion and electrically connect the grounding conductor to the conducting aluminum frame material.

**NOTE:** As a general rule, avoid direct contact of copper or copper alloy ground conductors with the aluminum frame to prevent galvanic corrosion. All ground bond securing hardware in contact with either the aluminum module frame and/or copper or copper alloy ground conductors must be stainless steel.

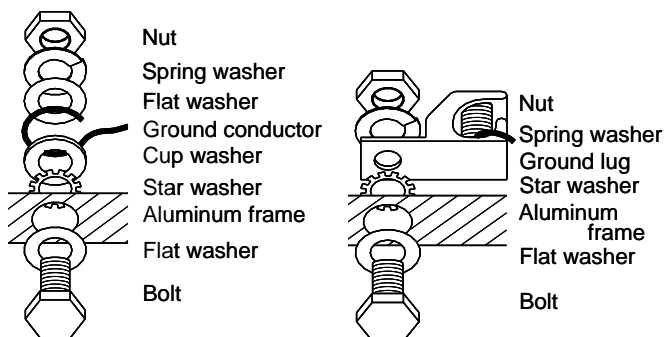

## 9. BLOCKING DIODES

In systems utilizing a battery, blocking diodes are typically placed between the battery and PV module output to

prevent battery from discharging at night. The PV module is made of polycrystalline cells with high electrical "back flow" resistance to nighttime battery discharging. As a result, the PV modules do not contain a blocking diode when shipped from the factory. Most PV charge regulators and inverters incorporate a nighttime disconnect feature.

## 10. BYPASS DIODES

Partial shading of an individual module in a source circuit string (i.e. two or more modules connected in series) can cause a reverse voltage across the shaded cells within the module. Module output current is then forced through the shaded area by the remaining illuminated cells and other PV modules in series with the partially shaded module(s). The current forced through the shaded cells within the PV module(s) causes additional module heating and severe loss of power. All the PV modules are supplied with factory installed (non user serviceable) bypass diodes.

The purpose of bypass diodes is to provide a low-resistance current path around the shaded cells, thereby minimizing PV module heating and array current losses.

The PV module employs bypass diodes that have:

- Rated Average Forward Current [ $I_{F(AV)}$ ] **Above** maximum system current at highest PV module operating temperature.
- Rated Repetitive Peak Reverse Voltage [ $V_{RRM}$ ] **Above** maximum system voltage at lowest PV module operating temperature.

## 11. MAINTENANCE

The PV module is designed for long life and requires very little maintenance. Under most weather conditions, normal rainfall is sufficient to keep the module glass surface clean. If dirt build-up becomes excessive, clean the glass surface only with a soft cloth using mild detergent and water. **USE CAUTION WHEN CLEANING THE BACK SURFACE OF THE PV MODULE TO AVOID PENETRATING BACK SHEET.** PV modules that are mounted flat (0° tilt angle) should be cleaned more often, as they will not "self clean" as effectively as modules mounted at a 15° tilt or greater. Once a year, check the general condition of the wiring and check to be sure that mounting hardware is tight. Loose connections may result in a damaged module or array.

### KYOCERA Solar Group Sales Office

- KYOCERA Corporation  
Corporate Solar Energy Group  
6 Takeda Tobadono-cho Fushimi-ku, Kyoto 612-8501, Japan  
Phone: 81-75-604-3476  
Fax: 81-75-604-3475  
<http://www.kyocera.com/>
- KYOCERA Solar, Inc.  
7812 East Acoma Drive, Scottsdale, AZ 85260, U.S.A.  
Phone: 1-480-948-8003 or 1-800-223-9580  
Fax: 1-480-483-6431  
<http://www.kyocerasolar.com/>
- KYOCERA Solar Pty Ltd.  
Level 3, 6-10 Talavera Road, North Ryde NSW 2113, Australia  
Phone: 61-2-9870-3946  
Fax: 61-2-9888-9673  
<http://www.kyocerasolar.com.au/>
- KYOCERA Solar do Brasil Ltda.  
Av. das Americas, 20007 – Bloco 2 – Salas (rooms) 105 to 108,  
Rio de Janeiro, 22790-851, Brazil  
Phone: 55-21-3724-3900  
Fax: 55-21-3724-3911  
<http://www.kyocerasolar.com.br/>

## 12. SPECIFICATIONS

- Under certain conditions, a photovoltaic module may produce more voltage and current than reported at Standard Test Conditions (STC). Refer to Section 690 of the National Electrical Code for guidance in series string sizing and choosing overcurrent protection.

### Module Specification

<b>Electrical Characteristics: @ STC</b>		
Module Type	KD315GX-LFB	KD320GX-LFB
Pmax	315W	320W
Voc	49.2V	49.5V
Isc	8.50A	8.60A
Vpm	39.8V	40.1V
Ipm	7.92A	7.99A
<b>Factory installed Bypass Diode</b>		
Number	4pcs.	
Series Fuse Rating	15A	
<b>Thermal Characteristics: Temp. Coefficient</b>		
Voc (V/°C)	$-1.77 \times 10^{-1}$	$-1.78 \times 10^{-1}$
[Voc (%/°C)]	[-0.36]	[-0.36]
Isc (A/°C)	$5.10 \times 10^{-3}$	$5.16 \times 10^{-3}$
[Isc (%/°C)]	$[6.0 \times 10^{-2}]$	$[6.0 \times 10^{-2}]$
Vpm (V/°C)	$-2.05 \times 10^{-1}$	$-2.06 \times 10^{-1}$
[Vpm (%/°C)]	[-0.52]	[-0.51]
<b>Physical Characteristics:</b>		
Length	65.43" (1662mm)	
Width	51.97" (1320mm)	
Depth	1.81" (46mm)	
Weight	60.6 lb (27.5kg)	
Mounting Hole	Diameter .35"(9mm), Quantity 4	
Grounding Hole	Diameter .28"(7mm), Quantity 4	
Application Class	Class A	

### NOTES

- The electrical characteristics are within +/-5% (UL verified 10% tolerance, according to UL 1703) of the installed values of Pmax and within +/-10% of the installed values of Isc and Voc under standard test conditions (irradiance of 1000W/m<sup>2</sup>, AM 1.5 spectrum, and a cell temperature of 25 deg C).
- See module specification sheet for most recent electrical characteristics.
- See module drawing for mounting and grounding holes locations.

