

## Model CST38MH

### 36" Wood Burning Fireplaces

P/N 700,033M, REV. C, 12/2006

**Retain These Instructions  
For Future Reference**



This installation manual will enable you to obtain a safe, efficient and dependable installation of your fireplace system. Please read and understand these instructions before beginning your installation.

Do not alter or modify the fireplace or its components under any circumstances. Any modification or alteration of the fireplace system, including but not limited to the fireplace, chimney components and accessories, may void the warranty, listings and approvals of this system and could result in an unsafe and potentially dangerous installation.

**IMPORTANT! TO ASSURE PROPER ALIGNMENT OF GLASS DOORS: INSTALL THIS FIREPLACE IN A SQUARE AND PLUMB CONDITION, USING SHIMS AS NECESSARY AT SIDES AND/OR BOTTOM.**

**NATIONAL  
FIREPLACE  
INSTITUTE**



**CERTIFIED**

[www.nficertified.org](http://www.nficertified.org)

We recommend that our woodburning hearth products be installed and serviced by professionals who are certified in the U.S. by the National Fireplace Institute® (NFI) as NFI Woodburning Specialists or who are certified in Canada by Wood Energy Technical Training (WETT).



Tested &  
Listed By



Beaverton  
Oregon USA

OMNI-Test Laboratories, Inc.

Report No. 116-F-20-4

## TABLE OF CONTENTS

Safety Rules .....	Page 2
Tools and Building Supplies .....	Page 2
Precautions .....	Page 2
Introduction .....	Page 3
Clearances/Height Requirements .....	Page 3
Chimney System .....	Page 3
Assembly Outline .....	Page 4
Location of Fireplace .....	Page 4
Assembly Steps .....	Page 5
Preinstallation Notes .....	Page 5
Clearances .....	Page 5
Installing the Fireplace .....	Page 5
Fireplace and Framing Specifications .....	Page 7
Framing Wall Variations .....	Page 8
Combustion Air Kits .....	Page 8
Installing the Chimney System .....	Page 9
Ten Foot Rule Summary .....	Page 13
Chimney Component Calculations .....	Page 13
Special Offset Instructions .....	Page 13
Offset Elevation Chart .....	Page 14
Vertical Elevation Chart .....	Page 15
Offset Calculations .....	Page 16
Installing Offsets .....	Page 16
30° Offset through Floor/Ceiling .....	Page 17
Glass Doors .....	Page 17
Gas Line Installation .....	Page 17
Cold Climate Insulation .....	Page 18
Fireplace Finishes .....	Page 18
Mantels and Trim .....	Page 18
Hearth Extensions/Wall Shields .....	Page 18
Finish Requirements .....	Page 20
Accessories And Components .....	Page 20

### PACKAGING LIST:

The assembled wood fireplace is packaged with:

- 1 - One envelope containing the literature package which consists of the homeowner's manual, installation instructions, warranty and combustion air cover (located in the firebox).
- 2 - One Combustion Air Kit (90L83).
- 3 - Two Door Sets.

## IMPORTANT: PLEASE READ AND UNDERSTAND THESE RULES TO FOLLOW FOR SAFETY.

### SAFETY RULES:

#### WARNING

**To avoid the risk of damaging fireplace materials and increasing the risk of fire, do not use the fireplace to cook or warm food.**

1. Before starting your fireplace installation, read these installation instructions carefully to be sure you understand them completely and in entirety. Failure to follow them could cause a fireplace malfunction resulting in serious injury and/or property damage.
2. Always check your local building codes. The installation must comply with all local, regional, state and national codes and regulations.
3. These fireplaces must be installed with Security Chimneys FTF8 (8" inside diameter) Chimney System only. These systems are intended for use in any application where a traditional masonry type fireplace would apply. The chimney system must always vent to the outside of the building.
4. To ensure a safe fireplace system and to prevent the build-up of soot and creosote, inspect and clean the fireplace and chimney prior to use and periodically during the heating season.
5. Burn approved fuels only as defined in the Homeowner's Care and Operation Manual.
6. DO NOT use charcoal or coal under any circumstances.
7. NEVER use gasoline, gasoline-type lantern fuel, kerosene, charcoal lighter fluid, or similar liquids to start or "freshen up" a fire in this fireplace. Keep any flammable liquids a safe distance from the fireplace.
8. NEVER leave children unattended when there is a fire burning in the fireplace.
9. Always keep flue damper open when heat is present in the fireplace.
10. Before servicing, allow the fireplace to cool. Always shut off any electricity or gas to the fireplace while working on it. This will prevent any possible electrical shock or burns.
11. This fireplace is not intended to heat an entire home or be used as a primary heat source. It is designed to ensure homeowner comfort by providing supplemental heat to the room.
12. Always ensure that an adequate supply of replacement combustion air from the outside of the house is accessible to the fire to support normal combustion. Fireplaces consume large volumes of air during the normal combustion process.
  - In the event the home is tightly sealed with modern energy efficient features, the combustion air kit (provided) may not provide all the air required to support combustion.
  - The manufacturer is not responsible for any smoking or related problems that may result from the lack of adequate combustion air. It is the responsibility of the builder/contractor to ensure that adequate combustion air has been provided for the fireplace.
13. Always ensure that the air inlet to the fireplace is free from debris and any other obstructions that can block the entrance of air.
14. DO NOT use a fireplace insert or any other product not specified by the manufacturer of this LHP appliance for use with this fireplace. All gas log sets must be operated with the damper clamped open.

NOTE: DIAGRAMS & ILLUSTRATIONS ARE NOT TO SCALE.

#### WARNING

**This fireplace has not been tested with an unvented gas log set. To reduce risk of fire or injury, do not install an unvented gas into this fireplace.**

15. "Smoke free" operation is not warranted nor are we responsible for inadequate system draft caused by mechanical systems, general construction conditions, inadequate chimney heights, adverse wind conditions and/or unusual environmental factors or conditions beyond our control.
16. Never, under any circumstances, install a fireplace, chimney component or any accessories, that has visible or suspected physical damage as a result of handling or transportation. These items should be inspected by your distributor or qualified factory representative to ensure safe condition. When in doubt, consult your distributor.
17. For additional safety considerations and complete operating instructions, refer to the Care and Operation Manual provided with the fireplace.

### TOOLS AND BUILDING SUPPLIES NORMALLY REQUIRED

Tools	Supplies
Phillips screwdriver	Framing materials
Hammer	Wall finishing materials
Saw and/or sabersaw	Caulking materials
Level	(noncombustible)
Measuring tape	Fireplace surround and
Plumb line	hearth extension
Electric drill and bits	materials
Pliers	(noncombustible)
Square	

### PRECAUTIONS

The most important areas of concern dealing with the installation of factory-built fireplaces are clearances to combustible materials, proper assembly of component parts, height of the chimney system, the proper use of accessories supplied by the manufacturer and the techniques employed in using finishing materials applied to the wall surrounding the fireplace, hearth extensions and wall shields. Each of these topics will be covered in thorough detail throughout this manual. Please give each your special attention as you progress with your installation.

*Note: These fireplace systems are not difficult to install. However, in the interest of safety, it is recommended that the installer be a qualified or certified "tradesman" familiar with commonly accepted fireplace installation and safety techniques as well as prevailing local codes.*

## INTRODUCTION

### General Information

The CST38MH Series is a radiant-heat, two-sided fireplace with standard glass doors and an outside combustion air kit is provided.

A steel grate is also included to properly position the fire and limit the amount of fuel. **IF A REPLACEMENT GRATE IS NEEDED REPLACE THE GRATE WITH MODEL SGR-38B ONLY.**

**Note:** Illustrations shown reflect "typical" installations with nominal dimensions and are for design and framing reference only. Actual installations may vary due to individual design preferences. However, always maintain minimum clearances to combustible materials and do not violate any specific installation requirements.

These fireplaces have been tested and listed by OMNI Test Labs (Report No. 116-F-20-4) to U.L. standard 127. These units are intended for installation in Manufactured Homes, residential homes and other buildings of conventional construction including commercial.

These fireplace systems are designed for installation in accordance with the National Fire Protection Standard for chimneys, fireplaces and solid fuel burning appliances; NFPA 211-latest edition and in accordance with codes such as the BOCA Basic/National Codes, the Standard Mechanical Code and the Uniform Building Codes.

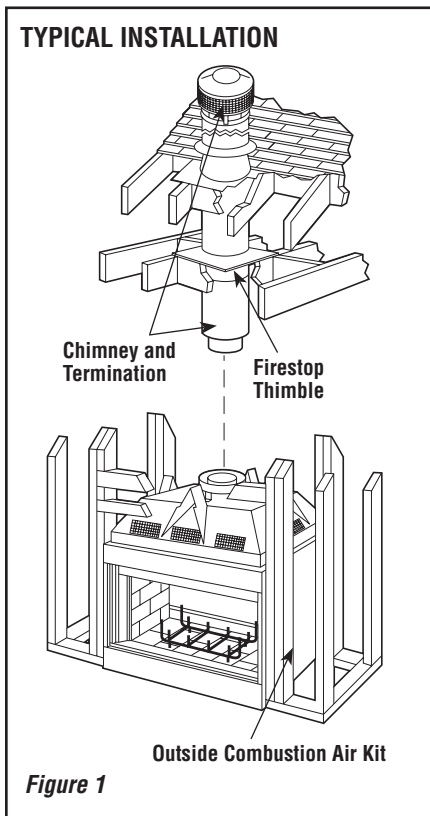

## ! WARNING

**Failure to use manufacture provided parts, variations in techniques and construction materials or practices other than those described in this manual may create a fire hazard and void the limited warranty.**

## ! WARNING

**Do not pack or fill required air spaces with insulation or other material. No material is allowed in these areas. Secure the airspace around the chimney with the firestop/thimble before completing the installation. Maintain 2" clearance between chimney and thimble.**

## ! WARNING

**If insulation is used, the fireplace must not be placed directly against it. Insulation or vapor barriers, if used, must first be covered with gypsum board, plywood, particle board or other material to assure insulation and vapor barriers remain in place.**

When complete these fireplace systems consists of four basic "sub-systems":

1. The Fireplace
2. The Chimney and Termination
3. Glass Doors
4. Combustion Air Kit

### CLEARANCES AND HEIGHT REQUIREMENTS

The fireplace may be placed on or near normal construction materials\*. The combustion air kit, firestop spacer and roof flashing (not chase flashings) may be placed directly on or against normal construction materials.\* The chimney and fireplace outer wrapper require a minimum 2" and 1/2" air space to combustibles respectively. A combustible mantel may be installed 12" above the opening of the fireplace as per NFPA 211-latest edition.

NOTE: DIAGRAMS & ILLUSTRATIONS ARE NOT TO SCALE.

The fireplace opening must be kept a minimum of 8" (203 mm) from a protected combustible side wall. A perpendicular side wall can not be closer than 18" (457 mm). If there is a continuous perpendicular side wall closer than 18" from the fireplace opening, it must be protected with a 40" x 40" x 1/2" (1016 mm x 1016 mm x 13 mm) wall shield constructed of a durable non-combustible material with an equal or greater insulating value than  $k=0.84$  BTU IN/FT<sup>2</sup> HR °F (refer to **Pages 18, 19 and 20**).

As with all chimney installations, avoid overhead obstructions such as trees, power lines, etc. Additionally chimney terminations must meet certain clearance to roof requirements detailed in the paragraph titled Ten-Foot Rule Summary.

The fireplace and chimney system must be enclosed when installed in or passing through a living area where combustibles or people may come in contact with it. This is important to prevent possible personal injury or fire hazard.

For questions, please call your distributor or the manufacturer. Special restrictions apply to the front and facing of the fireplace and nearby walls (See **Pages 18, 19 and 20**).

### CHIMNEY SYSTEM

These fireplaces are designed and code listed for use with Security Chimneys FTF8 chimney System only. Always use Security Chimneys FTF8 chimney components with these fireplaces. Do not modify or alter these components as this may cause a potential serious hazard and void the Warranty.

#### \*Construction Materials:

- Framing Materials
- Paneling
- Particle Board
- Flooring
- Dry Wall
- Plywood
- Noncombustible Insulating Materials
- Etc.

### Chimney Height

The total height of your Fireplace systems from the surface the fireplace rests on to the chimney top must not exceed 80' (24.4m) and must also meet minimum system height chart.

Minimum System Height Security's FTF8 Pipe	
Vertical Installation	15' 0"
One Offsets	16' 0"
Two Offsets	25' 0"
<b>Table 1</b>	

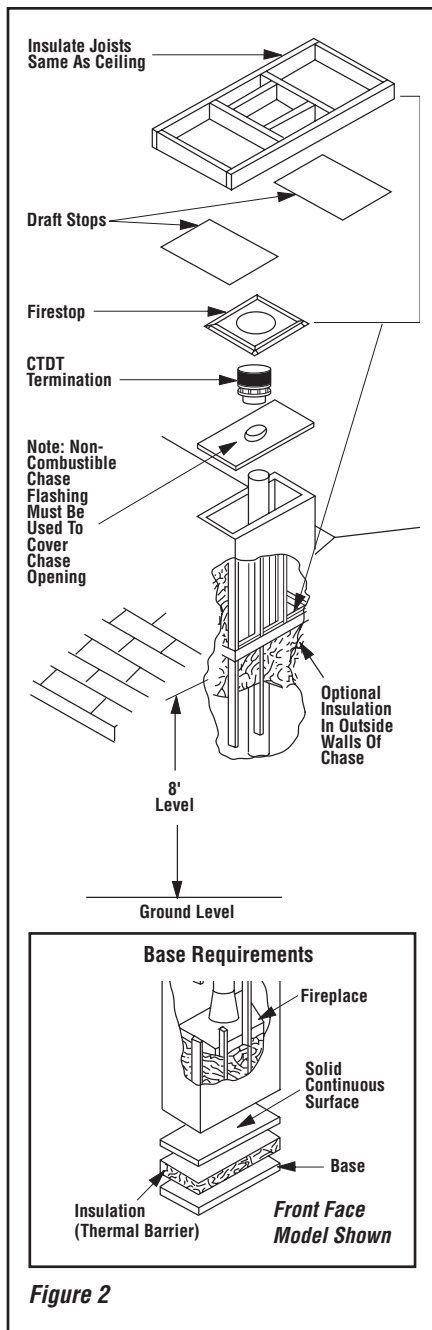

Figure 2

### Chimney Enclosure

Construct a box-like framed structure to enclose the fireplace and chimney within the confines of the manufactured home, not necessarily above the roof line.

As with all chimney installations, avoid overhead obstructions such as trees, power lines, etc. The chimney/fireplace enclosure should be constructed and insulated just like any outside wall. In a cold climate, we recommend the base of the chimney/fireplace enclosure should also be insulated between the solid continuous floor beneath the fireplace and the chase bottom. Insulation in a cold climate installation is not required for safety.

**Note:** Local codes may not require firestopping at the ceiling levels for outside chimney enclosure installations. However, it is recommended for safety and the reduction of heat loss.

**⚠ WARNING**

**Do not obstruct the collar openings around the base of the chimney at the top of the fireplace. Do not insulate the chase cavity with blown or fill type insulation materials.**

### ASSEMBLY OUTLINE Before You Start

Check your inventory list to be sure you have all the necessary parts supplied in good usable condition. Check also for any concealed damage.

Check the operation of the damper. The damper is controlled through the use of a control lever located within the firebox opening at the top center just behind the firebox lintel (Figure 3). The control lever snaps into place at the extreme range of motion, up and back in the closed position. When pulled forward and down, the damper is open.

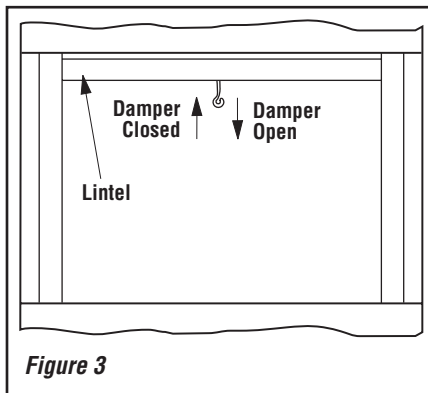

Figure 3

### LOCATION OF FIREPLACE

Carefully select the proper location for heat circulation, aesthetics, chimney obstructions and clearance to side wall(s). With proper pre-planning, a slight adjustment of a few inches can save considerable time and expense later during construction and assembly.

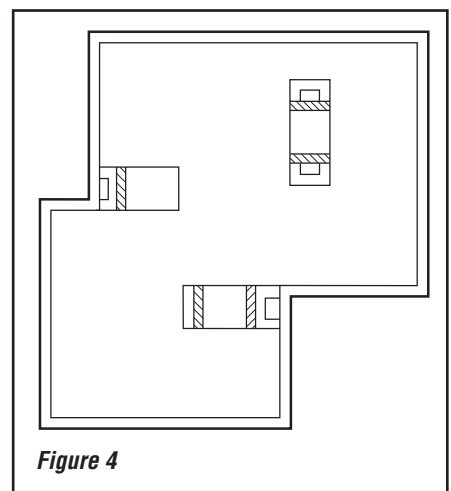

Figure 4

**⚠ WARNING**

**This fireplace and chimney system is not approved for use in a bedroom or any room used for sleeping.**

Carefully consider the position of the fireplace opening with respect to the location of adjacent or nearby stairwells, bath or kitchen exhaust fans and/or return air registers for forced air furnaces/air conditioners that could cause a smoking fireplace condition if the house is tightly insulated.

When locating the fireplace, consideration must be given to combustibles and final finishing. For an example of this, see Figure 5 and confine the final location of combustible finish materials to the "Safe Zone".

DO NOT permanently place furniture or other items such as decorative pillows within 60" of the fireplace front face.

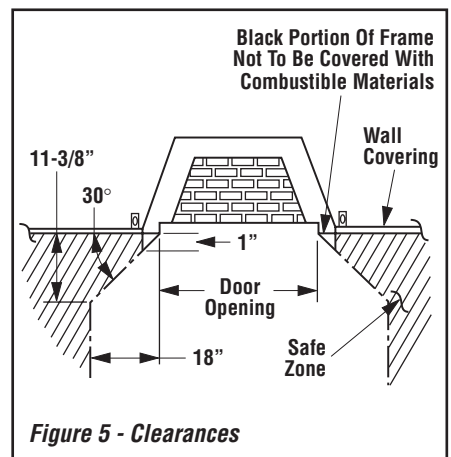

Figure 5 - Clearances

## ASSEMBLY STEPS

**Note:** The following steps represent the normal sequence of installation. Each installation is unique, however, and might require a different sequence.

1. Position firebox prior to framing or into prepared framing.
2. Install the chimney system.
3. Install outside combustion air kit.
4. Plumb gas line if a decorative gas appliance will be used. (Gas connections should only be performed by an experienced, licensed/certified tradesman).
5. Install both "All-Glass™" door assemblies.
6. Complete finish wall material, surround and hearth extension to your individual taste.
7. Install the glass doors provided.

Study the three dimensional illustration (**Figure 1**) to get a general idea of each element of your fireplace system.

## PRE-INSTALLATION NOTES

The fireplace may be installed directly on a combustible floor or raised on a platform of an appropriate height. Do not place fireplace on carpeting, vinyl or other soft floor coverings. It may, however, be placed on flat wood, plywood, particle board or other hard surfaces. Be sure fireplace rests on a solid continuous floor or platform with appropriate framing for support and so that no cold air can enter the room from under the fireplace.

The fireplace may be positioned and then the framing built around it, or the framing may be constructed and the fireplace positioned into the opening.

Usually, no special floor support is needed for the fireplace, however, to be certain:

1. Estimate the total weight of the fireplace system including chimney and surround materials such as brick, stone, etc., to be installed. Shipping weights for the fireplace may be found on **Page 7**.

2. Measure the square footage of the floor space to be occupied by the system, surrounds and hearth extensions.
3. Note the floor construction, i.e. 2 x 6's, 2 x 8's or 2 x 10's, single or double joists, type and thickness of floor boards.
4. Use this information and consult your local building code to determine if you need additional support.

### CAUTION

**Do not block the heat-circulating air inlet and outlet ports. Doing so may result in a potential fire hazard.**

### CAUTION

**The structural integrity of the manufactured home floor, wall, ceiling and roof must be maintained.**

The firestop thimble supplied with the unit must be used on a manufactured home installation. The firestop thimble must extend completely through the roof cavity to the outermost plane of the roof (See **Figures 21, 22 and 23**). Maintain 1" clearance between the thimble and the chimney.

If you plan to raise the fireplace and hearth extension, build the platform assembly then position fireplace and hearth extension on top. Secure the platform to the floor to prevent possible shifting.

## CLEARANCES

Minimum clearance to combustibles for the appliance is as follows: sides - 1/2" (12.5 mm), floor - 0" (0 mm), adjacent wall - 18" (457 mm), ceiling - 37-1/2" (953 mm).

## INSTALLING THE FIREPLACE

- Step 1.** Slide the fireplace into prepared framing or position fireplace in its final position and frame later.

The fireplace may not be recessed into a combustible floor. Maintain the floor to hearth clearance established by the fireplace lower front face.

- Step 2.** Insert the provided metal safety strips, beneath the fireplace as illustrated (**Figures 6 and 7**). The safety strips should overlap 1/2" for continual coverage of the floor.

**Note:** Safety strips are not required when fireplace rests on a noncombustible surface.

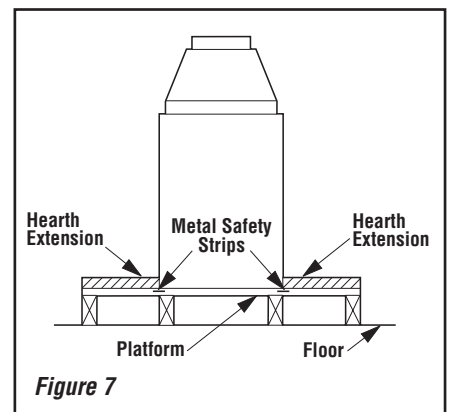
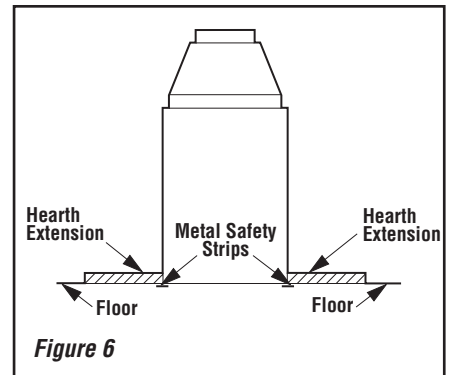

**Note:** Install the hearth extension only as illustrated.

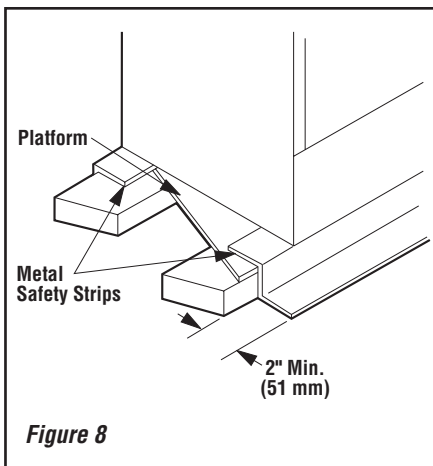

Figure 8

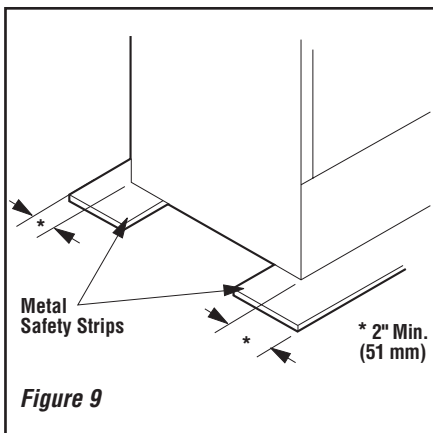

Figure 9

The safety strips should extend in front and sides of the fireplace opening 2" (51 mm). In the event a wooden support is used to elevate the fireplace above the floor, a "Z" type safety strip should be fabricated and used to protect the front surface of the wood support as well as the floor beneath the hearth extension (see **Figures 8 and 9**). The safety strips should be tacked down to prevent possible movement.

**Note:** The "Z" type safety strip is not supplied.

**Step 3.** Refer to fireplace drawings and specifications on **Pages 7 and 8** for framing dimensions and details. False header may be positioned directly on top of the fireplace spacers (see **Figures 10, 11 and 12**).

**! IMPORTANT**  
 Under no circumstances can the fireplace top spacers (**Figure 13**) be removed or modified, nor may you notch the header to fit around or be installed lower than the spacers. The header may be in direct contact with the top spacers but may not be supported by them.

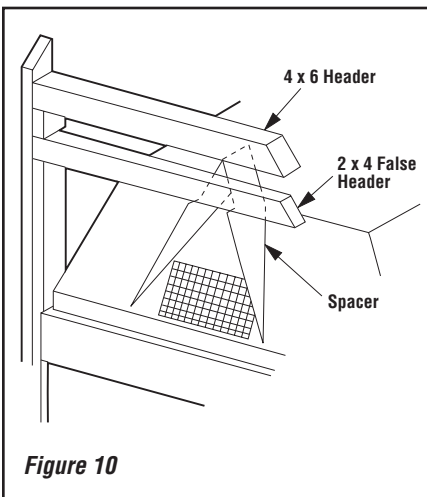

Figure 10

If the appliance is to be elevated above floor level, a solid continuous platform must be constructed.

The header may rest on the top metal spacers, but must not be notched to fit around them.

Consult all local codes.

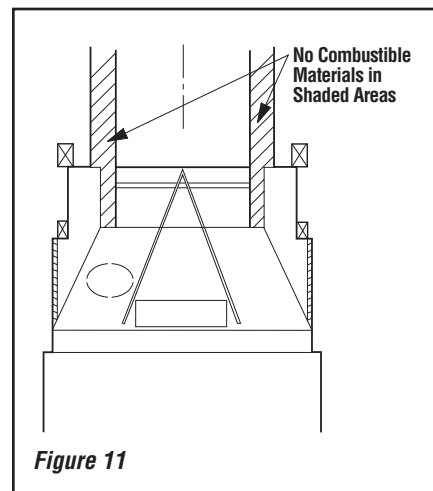

Figure 11

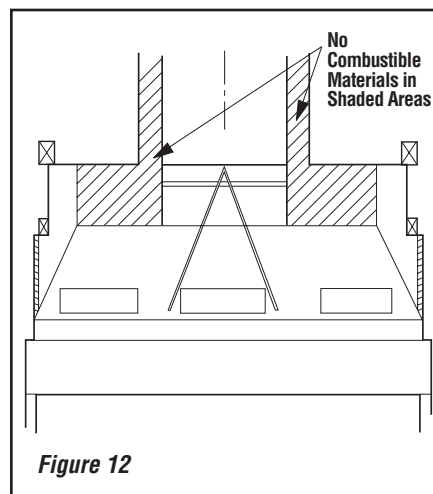
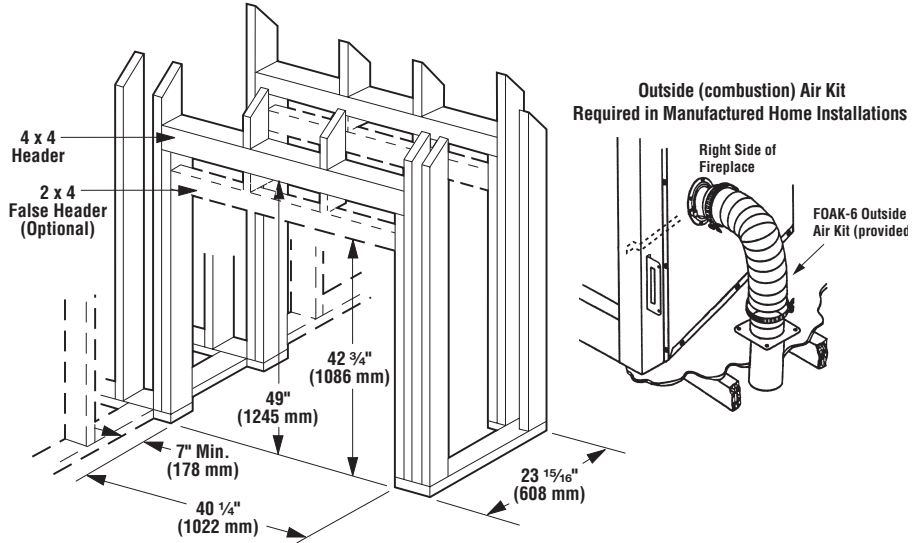

Figure 12

# FIREPLACE SPECIFICATIONS

Product Reference Information			
Cat. No.	Model	Ship. Weight	Ship. Volume
H4629	CST38MH	237 lb.	29.6 cu. ft.

Notes
Due to Lennox' ongoing commitment to quality, all specifications, ratings and dimensions are subject to change without notice.
All framing dimensions calculated for 1/2" dry wall at the fireplace face. If sheathing the chase or finishing with other thickness materials, calculations will need to be made.
See Page 8 for Ceiling and Roof Framing Dimensions
Diagrams & Illustrations Not to Scale



Tested & Listed By **O-TL** Beaverton Oregon USA  
 OMNI-Test Laboratories, Inc.  
 OTL Report No. 116-F-20-4

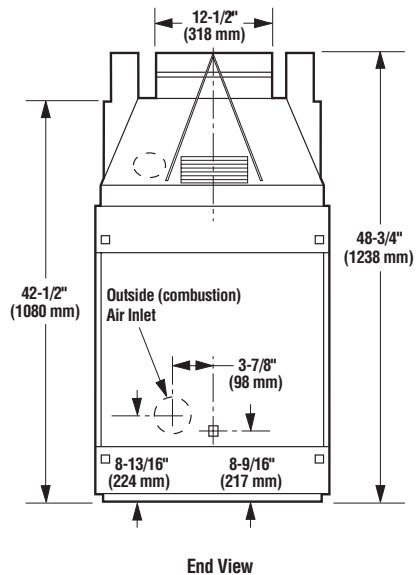
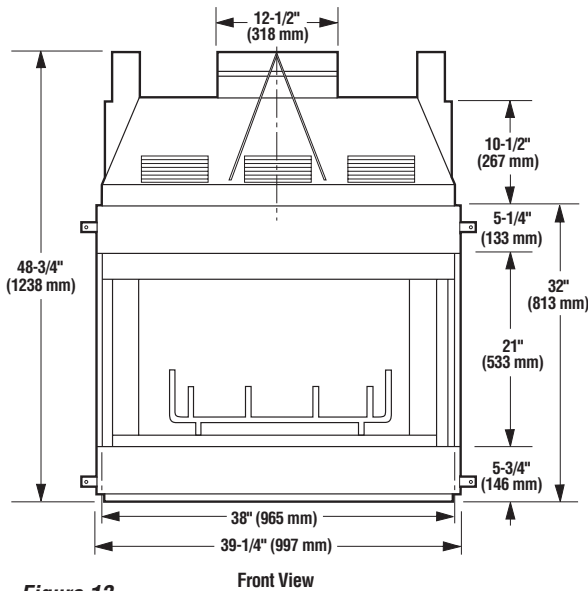
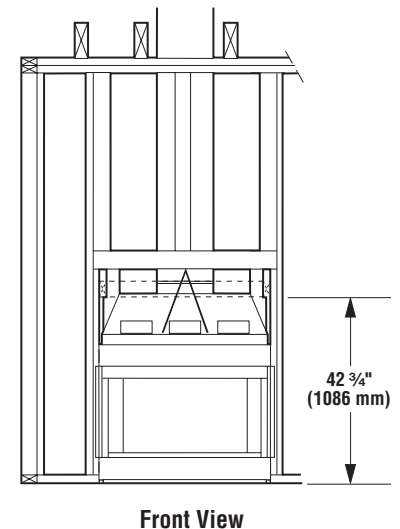
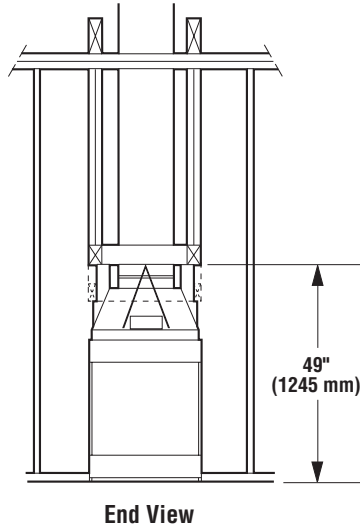
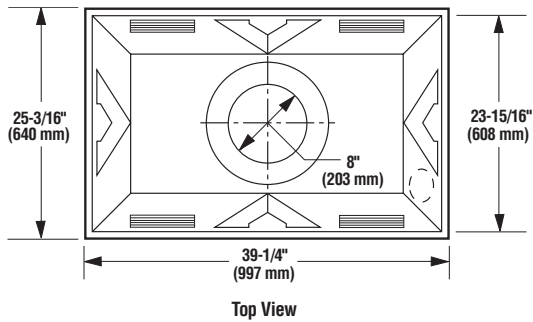
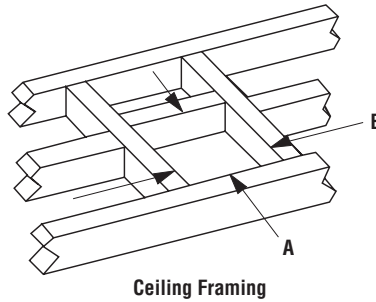
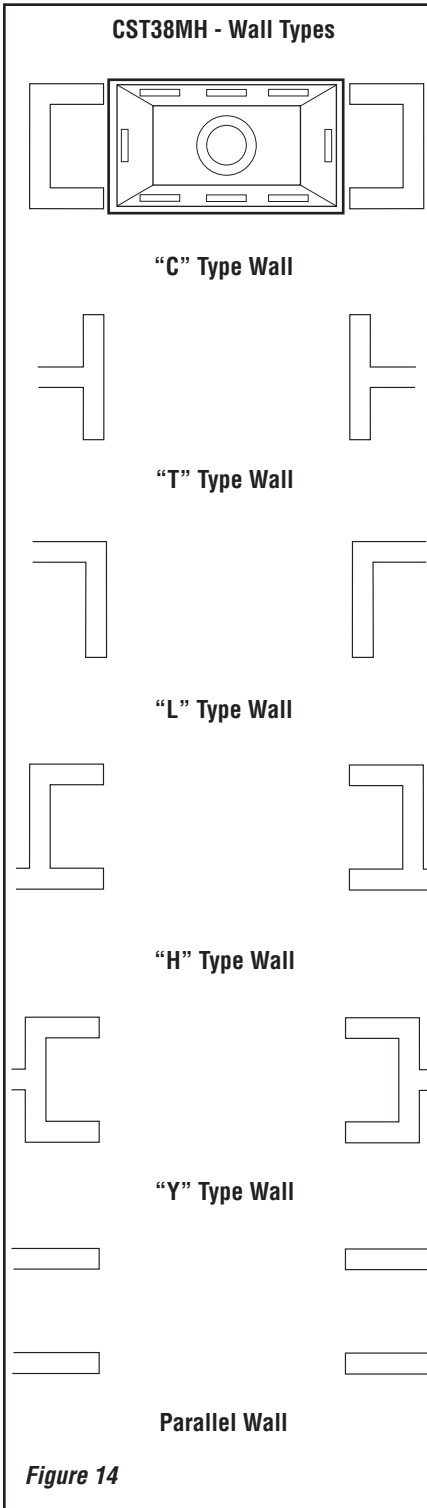

Figure 13

NOTE: DIAGRAMS & ILLUSTRATIONS ARE NOT TO SCALE.

## FRAMING WALL VARIATIONS

As many as six (6) different framed wall configurations can be constructed to enclose the Fireplaces. The following illustrations depict these variations of wall enclosures. Several of these designs may incorporate book shelves, wood storage boxes, etc.



**Framing Dimensions for Ceiling**

**Framing Dimensions for Ceiling  
Inches (millimeters)**

Flue Type	A	B
FTF8, Vertical at 2" (51 mm)	16 1/2" (419 mm)	16 1/2" (419 mm)
FTF8 Offset 30° At 2" (51 mm)	16 1/2" (419 mm)	27" (686 mm)

**Figure 15**

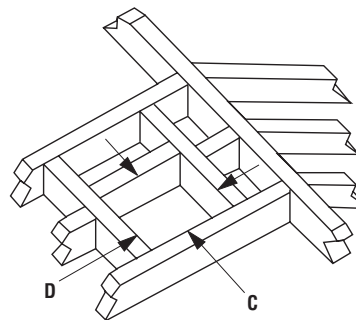

**Framing Dimensions for Roof  
Inches**

Pitch	FTF8 at 1" (USA)	
	C	D*
0/12	16 1/2"	16 1/2"
6/12	16 1/2"	19"
12/12	16 1/2"	23 1/2"

\* Perpendicular to roof ridge

**Figure 16**

**Step 4.** The fireplace should be secured to side framing members using nailing tabs. Use 8d nails (**Figure 17**).

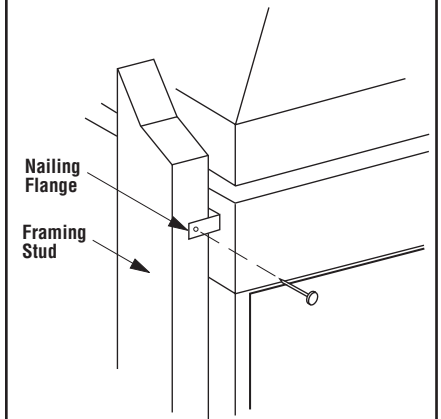

**Figure 17**

**Note:** The nailing tabs are exempt from the fireplace clearances described on the fireplace clearance label.

### INSTALL THE COMBUSTION AIR KIT (required in Manufactured Home installations)

Outside air drawn into the fireplace supplies air to the fire for combustion. The outside air kit (FOAK-6, Cat. No. 90L83) must be installed before the fireplace is framed and enclosed in the finished walls.

Install the air intake *Collar* (provided) as shown in **Figure 18**.

There is a one-hand operated shut-off valve located in the enclosed corner of the fireplace opening behind the screen. Refer to label for directions of operation. The combustion air damper should be fully open when the fireplace is in operation and fully closed when the fireplace is not in use to prevent outside air from entering your home.

Connect the 6" (152 mm) Class 0 or Class 1 air duct to the outside air collar on the appliance with the tie strip in the outside air kit (provided). See **Figure 18**.

Route the Class 0 or Class 1 air duct out the back or side wall, up through the ceiling or floor joists to an outside wall. The air duct should be located above snow level.

Outside combustion air may be run upwards or vertically through framing and ceiling joists, with the hood installed through an outside wall and 3' (914 mm) below the termination. Ducting may also be run downward through floor joists and under the home to a ventilated crawlspace not considered part of the living area of the home.



Cut or frame a hole through the outside wall for the installation of the duct inlet hood. A 6 1/2" (151 mm) diameter hole is sufficient. Feed the loose end of the flexible air duct through the hole cut for the inlet hood and attach to collar on inlet hood using the tie strip provided. Insert hood into opening. Secure in place with the No. 8 x 1-1/2" screws provided or with nails driven through holes in hood flange. Seal with noncombustible waterproof silicon type caulking. If additional length of duct is necessary, purchase locally available Class 0 or Class 1 ducting. The duct may extend up to 50' (15.2 m) in any direction.

**Note:** Do not terminate combustion air kit in attic space under any circumstances.

**CAUTION**  
 Never locate the air inlet where it could be blocked by shrubs, leaves, snow drifts, etc. Never locate the air inlet in garage or any area where there is another fuel burning appliance or products emitting combustible gases such as paint, gasoline, etc. In cold climates, it is recommended that the combustion air duct be insulated.

**CAUTION**  
 In no event may the total duct for bringing in outside air exceed 50' (15.2 m).

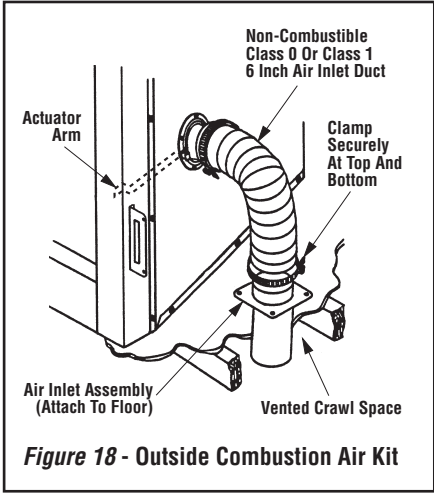

**INSTALLING THE CHIMNEY SYSTEM**

**Step 1.** Check flue damper for proper operation. To open, push handle up and release. Damper will open automatically. To close, pull handle down and release damper will fall to the closed position.

**Note:** The damper may be operated from both firebox openings.

**Step 2.** Using standard construction framing techniques, construct opening for chimney route up through the ceiling(s) and roof or through an outside chase.

Framing must maintain adequate minimum air space clearance at all times.

**CAUTION**  
 Allow minimum 2" (51 mm) chimney air space to combustible framing members throughout vertical or offset chimney installation. Also maintain air space on top of the fireplace as defined by the spacers and standoffs.

A minimum 2" (51 mm) air space must be reserved for all combustible materials extending for any continuous length surrounding the chimney.

Reference **Figures 15 and 16** on **Page 8**, which specify minimum ceiling and roof dimensions.

NOTE: DIAGRAMS & ILLUSTRATIONS ARE NOT TO SCALE.

For new construction, to determine chimney center line, use plumb line from roof or ceiling above fireplace to center of flue collar on fireplace.

For remodeling, plumb to center of flue collar from ceiling above, drive nail through ceiling from below to mark position, then mark and cut to passage from above ceiling (around nail) (Figure 19). Then plumb from ceiling or roof level directly above hole which has just been completed.

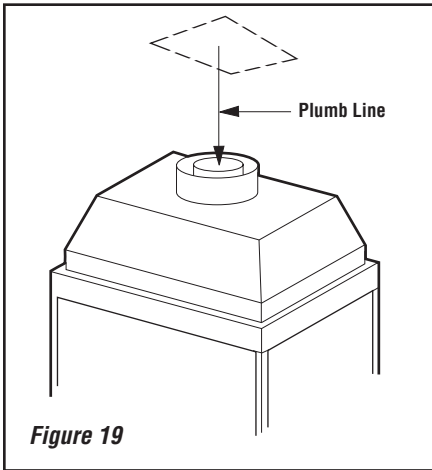

Figure 19

**Step 3.** Position appropriate thimble/firestop spacer combination at ceiling and nail temporarily with two (2) 8d nails or equivalent fasteners (see Figures 21, 22 and 23). Use thimble/firestop spacer, model FM8-AT2, if chimney penetrates ceiling vertically. If chimney penetrates ceiling at 30° angle (offset) chimney use Model F8FS30-2. Use one fastener on opposite sides to hold thimble/firestop spacer combination in position. Nail permanently, using at least two (2) more fasteners, after chimney sections have been assembled through the thimble/firestop spacer combination and after any necessary adjustments have been made. Firestop spacer must be secured by at least four (4) fasteners when completely installed.

**Note:** If there is a room above ceiling level, firestop spacer must be installed on the bottom side of the ceiling. If an attic is above ceiling level, firestop spacer must be installed on top side of ceiling joist (Figure 20).

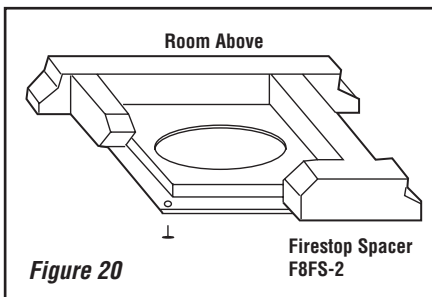

Figure 20

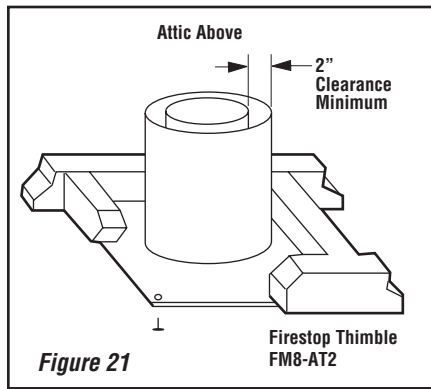

Figure 21

Ensure the thimble penetrates the roof opening. The thimble must extend completely through the ceiling or roof cavity to the outermost plane of the roof. Note: Thimble extensions (F8-TE26-2) are available from your dealer for constructions in which the distance between the outside of the roof and the inside of the ceiling exceeds 13". The thimbles and their extensions provide for zero clearances to combustibles and must be used at the ceiling/roof in manufactured homes (Figures 22 and 23).

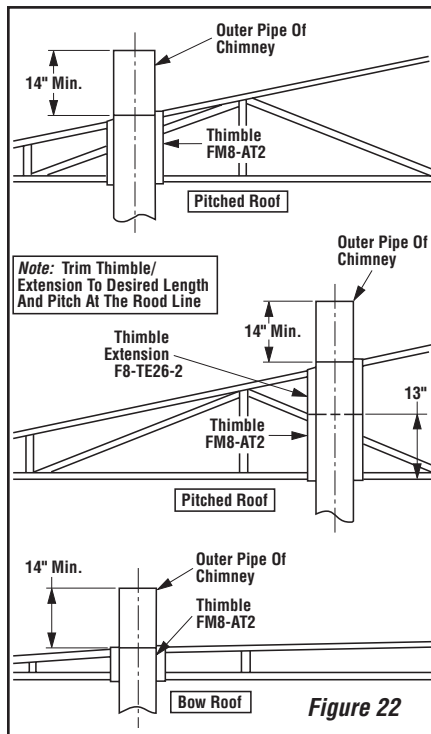

Figure 22

**WARNING**  
Do not allow insulating materials to be blown into the space inside the thimble and the chimney. To do so could result in a fire hazard.

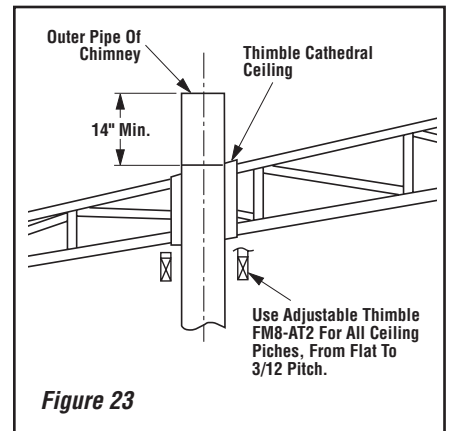

Figure 23

**Step 4. Note:** Chimney sections are constructed with a unique locking tab design, which ensures an immediate, tight assembly between sections. Plan your chimney requirements carefully before assembly as chimney is difficult to disassemble after installation. If disassembled, the tabs might become damaged. Be certain tabs are properly formed to ensure locking tabs engage properly.

The Security Chimneys FTF8 chimney system is a two piece chimney, which snap together from the fireplace up. Start with the inner flue section with the lanced end up, snap lock it in to the matching collar on top of the fireplace. At all subsequent joints, the upper flue section fits into the preceding flue section. Each piece snaps together by means of locking tabs (9 locking tabs per joint). Check each piece by pulling up slightly from the top to ensure proper engagement before installing the next section. If the flue has been installed correctly, it will not separate when you test it. Also, the inner flue joint where each section is joined should be tight and flat without gaps (Figure 24).

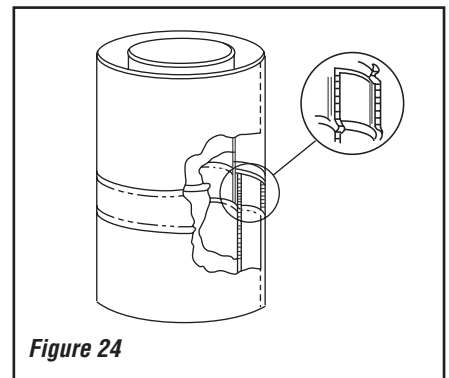
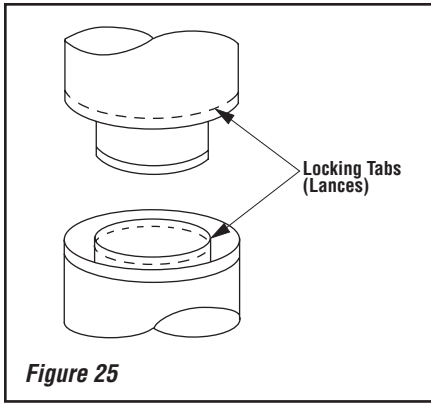

Figure 24

Outer pipe section installs in just the opposite way; the lanced end goes down and each new section goes OVER the outside of the previous section installed (Figure 25).



**Note:** Assemble one component of chimney at a time (inner section first, then outer section last) before proceeding with the next complete section.

Continue to assemble the chimney up through framed ceiling opening. Assemble just enough to penetrate the roof flashing openings (**Figure 26**). Always maintain 2" (51 mm) minimum air space to combustible materials and always check each pipe joint (inner and outer) to ensure proper engagement. Check vertical alignment of chimney so that it projects from the roof in true vertical position.

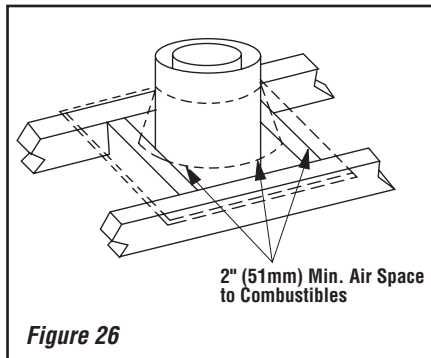

Security's chimney sections do not need to be screwed together. Additional reinforcement is not necessary except in certain offset conditions (refer to **Page 16, Figure 38**).

**Step 5.** The height of vertical chimney pipe supported only by the fireplace must not exceed 30'. Chimney heights above 30' must be supported by a Model FTF8-S4 stabilizer installed at 30' intervals.

**Note:** The Model FTF8-S4 adds 3" net effective height to the total chimney system.

Install the Model FTF8-S4 stabilizer by fitting inner section down into respective section of proceeding flue pipe and locking outer stabilizer section into place over the outer chimney pipe. Position for proper clearance through framed opening and nail straps securely (under tension in "shear") into place on framing. Use 8d nails. Attach successive lengths of chimney pipe directly to stabilizer using same techniques as described in **Step 4 (Figure 27)**.

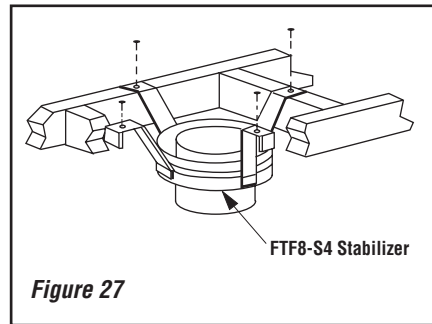

**Note:** Do not apply excessive pressure to any subsequent chimney sections following the stabilizer when installing. Ensure each subsequent chimney section is securely attached by testing as noted in **Step 4**.

**Step 6.** Select the proper Security Chimneys roof flashing based on pitch of roof. Use chart below for selection:

Roof Pitch	FTF8
Flat to 6/12	F8-F6
6/12 to 12/12	F8-F12

**Table 2**

Next, slide roof flashing over extended chimney section that previously has been installed above the roof opening in **Step 4**. Slide flashing all the way down until the flashing base rests flat on the roof (**Figure 28**). Again, check the vertical position of the chimney and the minimum air space to combustibles.

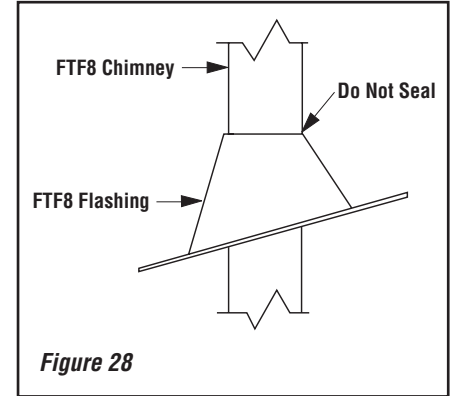

**Step 7.** Secure flashing by nailing along the perimeter into roof using 8d nails or equivalent fasteners. If shingled roof, slide upper end and sides of roof flashing under shingles (trim if necessary), seal the top and both sides of the flashing to the roof with roof caulking. Cover fastener heads with roof caulking (**Figure 29**).

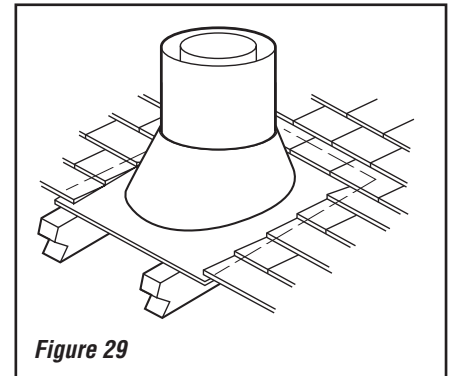

**Step 8.** The standard Security Chimneys FTF8 roof flashing assemblies include a storm collar. Slide the storm collar over outer chimney, rest on flashing spacers and align with top surface of flashing. Insert tab in slot, pull tight and bend tab back over slot. Seal storm collar to outer chimney with roof caulking or mastic around entire circumference of pipe. Also add extra roof caulking to the tab/slot area to seal completely against water penetration (**Figure 30**). Check all joints very carefully to ensure no water intrusion can take place.

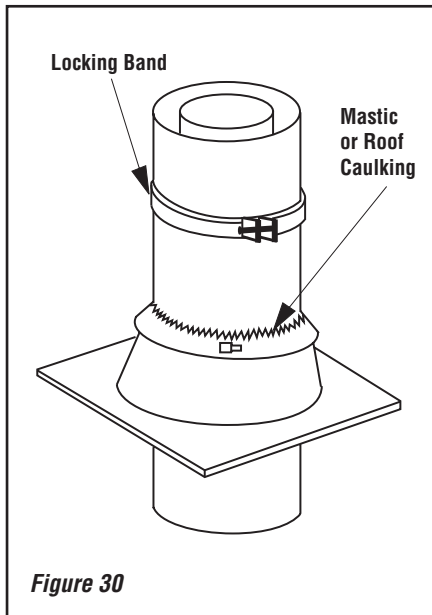

**Figure 30**

**Step 9.** FTF locking bands, Model FLB, may be required if the chimney extends too high above the roof flashing. As a general rule, if the chimney extends more than 6' above the roof flashing, the use of locking bands is advisable to strengthen the chimney assembly. Align the locking band at the chimney joint. Locking bands wrap around pipe joints equally covering the joints of both pipe sections. Use the nut provided and TIGHTEN snugly. Do not overtighten as this might damage the chimney section (refer to **Figure 25**).

**Note:** If chimney extends more than 8' (2.4 m) above roof surface, guy wires are also recommended. Use three (3) guy wires, attach to locking band assembly, extend and secure to roof in a triangular pattern (**Figure 31**). Guy wires are not supplied by the manufacturer.

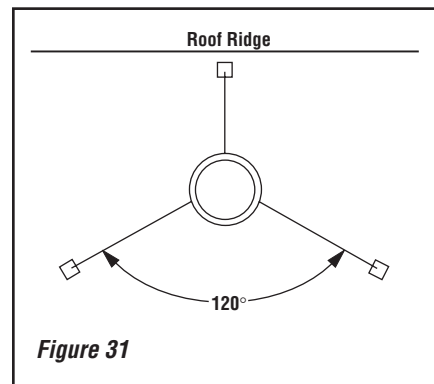

**Figure 31**

**Step 10. Using an FTF8-CTD Round Termination:**

1. Hold the CTD over top of last chimney section (**Figure 32**).
2. Center inner slip section in inner flue pipe-slip down.

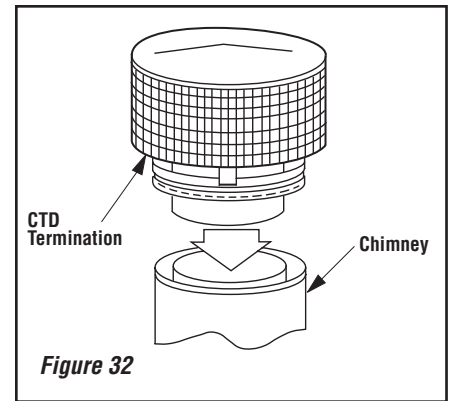

**Figure 32**

3. Center outer locking section over outer flue pipe. Push down until locking tabs are firmly engaged.
4. Pull up slightly on CTD to ensure locking joint has firmly engaged.

**Note:** It is recommended that all exterior exposed metal fireplace components; such as terminations, flashings, storm collars and/or flue be painted with a premium quality, high temperature, rust preventative paint designed for metal. This is especially important when installations are made in abnormally adverse or corrosive environments; such as near lakes, oceans or in areas with consistently high humidity conditions. Consult the paint manufacturer's instructions for proper preparation and application.

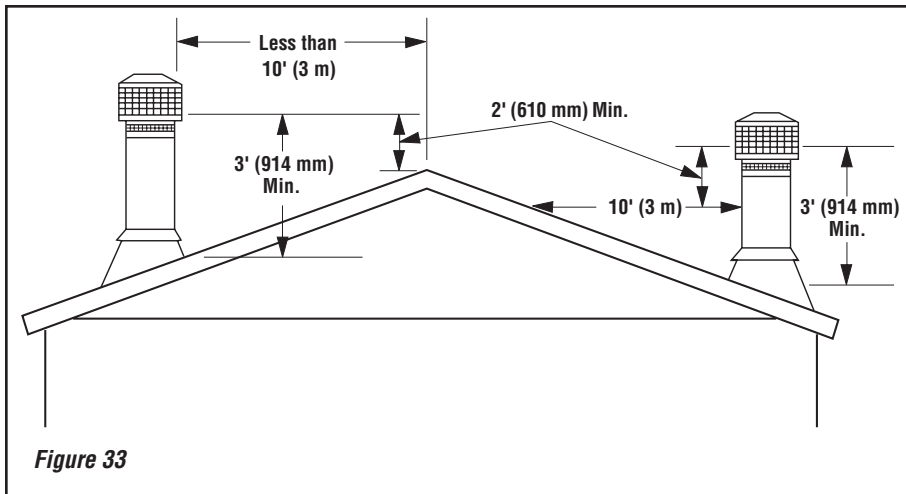

Figure 33

### TEN FOOT RULE SUMMARY

The minimum chimney height above the roof and/or to adjacent walls and buildings is specified by all major building codes.

If the horizontal distance from the peak of the roof is less than 10' (3 m), the top of the chimney must be at least 2' (610 mm) above the peak of the roof.

If the horizontal distance from the chimney edge to the peak of the roof is more than 10' (3 m), a chimney height reference point is established on the roof surface located horizontally 10' (3 m) from the chimney edge. The top of the chimney must be at least 2' (610 mm) above this reference point. In all cases, the chimney cannot be less than 3' (914 mm) above the roof at the edge of the chimney.

The 2' in 10' rule is necessary in the interest of safety, but does not ensure smoke-free operation. Trees, buildings, adjoining roof lines, adverse wind conditions, etc., may require a taller chimney should the fireplace not draft properly (see **Figure 33**).

### FTF8 CHIMNEY COMPONENT CALCULATIONS

The minimum installed height of the completed fireplace system is 15". The maximum system height is 80' 0".

To determine the number of chimney sections and chimney components required, follow these steps:

1. Determine total vertical height of the fireplace installation. This dimension is the distance from the surface the fireplace sets on to the point where smoke exits from the termination.
2. Determine the number of chimney components required, except chimney sections. This would include thimbles, extensions, roof flashing, etc.

3. The effective heights of the components are:

<b>The Fireplace</b>	<b>= 48"</b>
<b>FTF8-12</b>	<b>= 10-1/4"</b>
<b>FTF8-18</b>	<b>= 16-1/4"</b>
<b>FTF8-24</b>	<b>= 22-1/4"</b>
<b>FTF8-36</b>	<b>= 34-1/4"</b>
<b>FTF8-48</b>	<b>= 46-1/4"</b>
<b>FTF8-CTD Termination</b>	<b>= 6"</b>

4 Determine amount of chimney height required by subtracting total combined height of all pre-selected components (fireplace and chimney components from total desired height).

Reference Vertical Elevation Chart and determine the number of chimney sections (quantity and length) required. in **Table 4 on Page 15**.

### SPECIAL OFFSET INSTRUCTIONS

To clear any overhead obstructions, you may offset your chimney system using Security Chimneys 30° offset and return elbows. Use two elbows - an offset elbow to initiate the offset and a return elbow to terminate it. A 30° offset elbow, angling in any direction, may be the first component used off the top of the fireplace flue collar. Maintain 2" minimum air space to combustibles from chimney sections. See **Figures 41 and 42**.

## OFFSET ELEVATION CHART

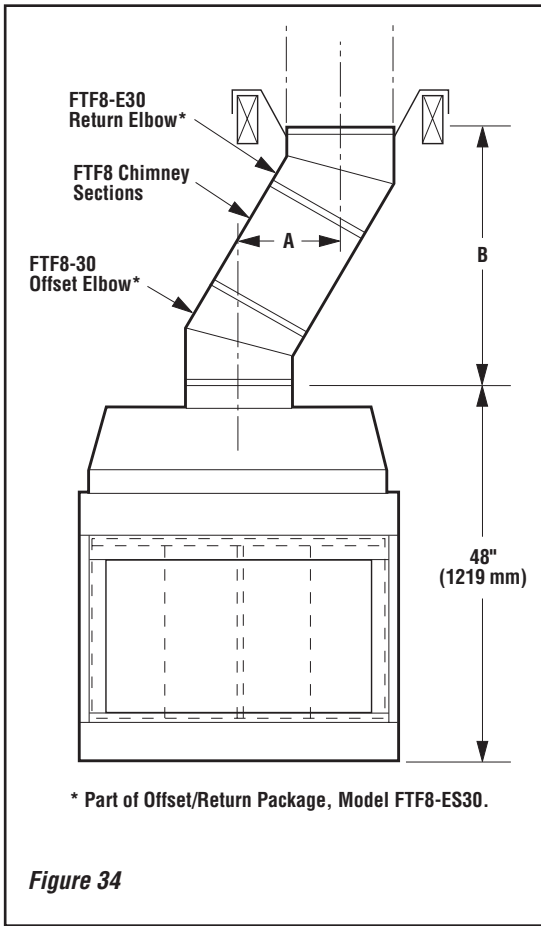

**Figure 34**

A Offset (Inches)	B Height (Inches)	FTF8-ES30 Offset/Return Elbow Set	FTF8-S4 Stabilizer	Number of FTF8 Chimney Sections				A Offset (mm)	B Height (mm)
				12"	18"	36"	48"		
4	15	1	0	0	0	0	0	102	400
9	24	1	0	1	0	0	0	229	622
12	29	1	0	0	1	0	0	305	756
14	33	1	0	2	0	0	0	362	851
17	38	1	0	1	1	0	0	438	978
20	43	1	0	0	2	0	0	514	1111
21	45	1	0	0	0	1	0	533	1149
22	47	1	0	2	1	0	0	565	1207
25	52	1	0	1	2	0	0	641	1334
26	54	1	0	1	0	1	0	667	1378
27	55	1	0	0	0	0	1	686	1416
28	57	1	0	0	3	0	0	718	1467
29	59	1	0	0	1	1	0	743	1505
31	63	1	0	2	0	1	0	794	1600
32	64	1	0	1	0	0	1	819	1638
34	68	1	0	1	1	1	0	870	1734
35	69	1	0	0	1	0	1	895	1772
37	73	1	0	0	2	1	0	946	1861
38	75	1	0	0	0	2	0	972	1905
39	77	1	0	2	1	1	0	997	1956
41	80	1	0	1	4	0	0	1054	2045
43	83	1	0	1	0	2	0	1099	2127
44	85	1	0	0	0	1	1	1124	2165
45	87	1	0	0	3	1	0	1149	2223
46	89	1	0	0	1	2	0	1175	2261
48	91	1	0	2	0	2	0	1226	2324
49	94	1	0	1	0	1	1	1251	2394
50	95	1	0	0	0	0	2	1276	2432
51	97	1	0	1	1	2	0	1302	2483
54	103	1	0	0	2	2	0	1378	2616
55	104	1	0	1	0	0	2	1403	2654
56	106	1	0	2	1	2	0	1435	2705
58	109	1	0	0	1	0	2	1480	2788
62	116	1	1	1	0	3	0	1588	2965
65	122	1	1	0	1	3	0	1664	3099
67	125	1	1	2	0	3	0	1721	3188
69	128	1	1	0	0	1	2	1765	3270
70	130	1	1	1	1	3	0	1797	3321
73	136	1	1	0	2	3	0	1873	3454
75	139	1	1	0	0	0	3	1918	3531
79	146	1	1	1	0	4	0	2026	3715
80	148	1	1	1	0	0	3	2051	3759
82	151	1	1	0	1	4	0	2102	3848
83	153	1	1	0	1	0	3	2121	3886

**Table 3**

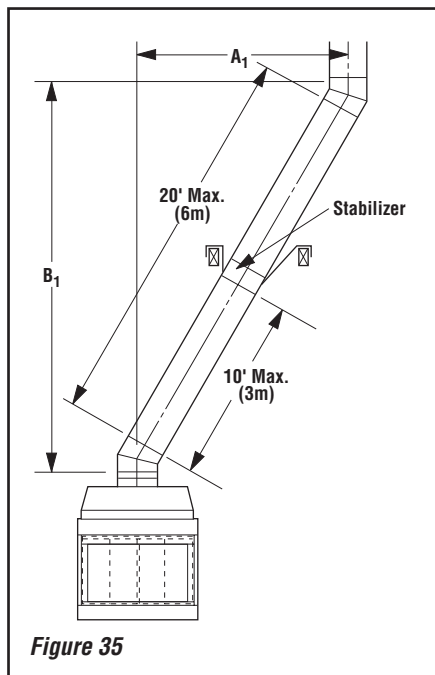

**Figure 35**

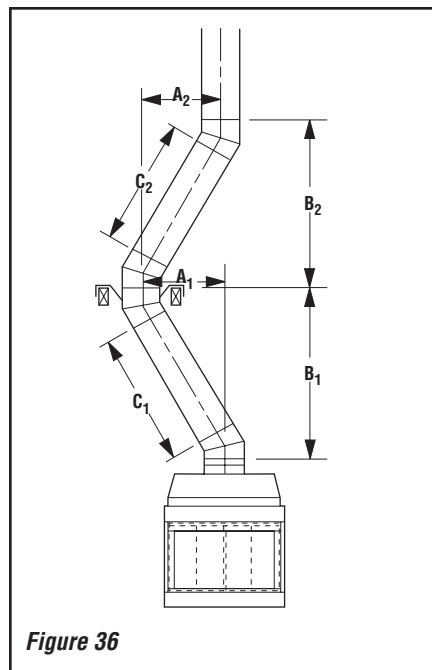

**Figure 36**

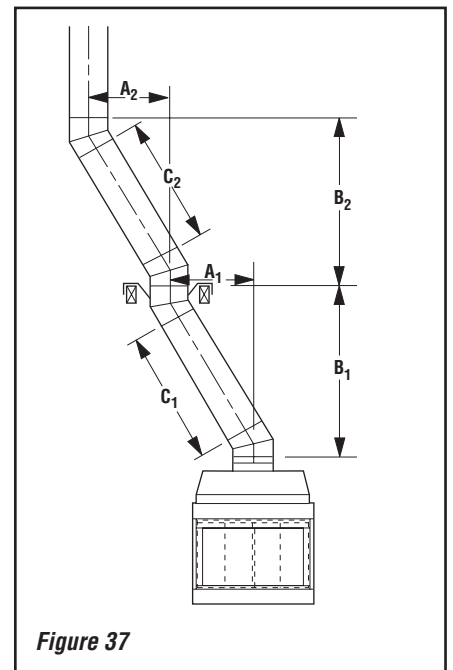

**Figure 37**

NOTE: DIAGRAMS & ILLUSTRATIONS ARE NOT TO SCALE.

## FTF8 VERTICAL ELEVATION CHART

Height Of Chimney Only		Number Of FTF8 Chimney Lengths				Height Of Chimney Only		Height Of Chimney Only		Number Of FTF8 Chimney Lengths				Height Of Chimney Only	
Inches	Feet/Inches	12"	18"	36"	48"	MM	M	Inches	Feet/Inches	12"	18"	36"	48"	MM	M
11	0 11	1	0	0	0	279	0.28	252	21 0	2	0	0	5	6401	6.40
17	1 5	0	1	0	0	432	0.43	258	21 6	1	1	0	5	6553	6.55
21	1 9	2	0	0	0	540	0.54	266	22 2	0	0	1	5	6756	6.76
27	2 3	1	1	0	0	692	0.69	276	23 0	1	0	1	5	7010	7.01
35	2 11	0	0	1	0	889	0.89	278	23 2	0	0	0	6	7061	7.06
47	3 11	0	0	0	1	1194	1.19	282	23 6	0	1	1	5	7163	7.16
51	4 3	0	1	1	0	1302	1.30	288	24 0	1	0	0	6	7315	7.32
57	4 9	1	0	0	1	1454	1.45	294	24 6	0	1	0	6	7487	7.49
63	5 3	0	1	0	1	1607	1.61	298	24 10	2	0	0	6	7576	7.58
67	5 7	2	0	0	1	1708	1.71	304	25 4	1	1	0	6	7728	7.73
73	6 1	1	1	0	1	1861	1.86	312	26 0	0	0	1	6	7925	7.93
81	6 9	0	0	1	1	2064	2.06	322	26 10	1	0	1	6	8185	8.19
93	7 9	0	0	0	2	2369	2.37	324	27 0	0	0	0	7	8230	8.23
97	8 1	0	1	1	1	2470	2.47	328	27 4	0	1	1	6	8338	8.34
102	8 6	1	0	0	2	2604	2.60	334	27 10	1	0	0	7	8490	8.49
109	9 1	0	1	0	2	2775	2.78	340	28 4	0	1	0	7	8642	8.64
113	9 5	2	0	0	2	2883	2.88	344	28 8	2	0	0	7	8750	8.75
119	9 11	1	1	0	2	3035	3.04	350	29 2	1	1	0	7	8903	8.90
127	10 7	0	0	1	2	3232	3.23	358	29 10	0	0	1	7	9100	9.10
137	11 5	1	0	1	2	3493	3.49	368	30 8	1	0	1	7	9360	9.36
139	11 7	0	0	0	3	3537	3.54	370	30 10	0	0	0	8	9404	9.40
143	11 11	0	1	1	2	3645	3.65	374	31 2	0	1	1	7	9512	9.51
149	12 5	1	0	0	3	3797	3.80	380	31 8	1	0	0	8	9665	9.67
155	12 11	0	1	0	3	3950	3.95	386	32 2	0	1	0	8	9817	9.82
159	13 3	2	0	0	3	4058	4.06	390	32 6	2	0	0	8	9925	9.93
165	13 9	1	1	0	3	4210	4.21	396	33 0	1	1	0	8	10077	10.08
173	14 5	0	0	1	3	4407	4.41	404	33 8	0	0	1	8	10274	10.27
183	15 3	1	0	1	3	4667	4.67	414	34 6	1	0	1	8	10535	10.53
185	15 5	0	0	0	4	4712	4.71	416	34 8	0	0	0	9	10579	10.58
189	15 9	0	1	1	3	4820	4.82	420	35 0	0	1	1	8	10687	10.69
195	16 3	1	0	0	4	4972	4.97	426	35 6	1	0	0	9	10839	10.84
201	16 9	0	1	0	4	5124	5.12	432	36 0	0	1	0	9	10992	10.99
206	17 2	2	0	0	4	5232	5.23	437	36 5	2	0	0	9	11100	11.10
212	17 8	1	1	0	4	5385	5.39	443	36 11	1	1	0	9	11252	11.25
219	18 3	0	0	1	4	5582	5.58	450	37 6	0	0	1	9	11449	11.45
230	19 2	1	0	1	4	5842	5.84	461	38 5	1	0	1	9	11709	11.71
231	19 3	0	0	0	5	5886	5.89	462	38 6	0	0	0	10	11754	11.75
236	19 8	0	1	1	4	5994	5.99	466	38 10	0	1	1	9	11855	11.86
242	20 2	1	0	0	5	6147	6.15	472	39 4	1	0	0	10	12008	12.01
248	20 8	0	1	0	5	6299	6.30	478	39 10	0	1	0	10	12160	12.16

**Table 4**

The offset and return elbows may be attached together, or a section or sections of chimney may be used between, but do not exceed 20' (6.1 m) in total length between elbows (**Figure 35**). If sections of pipe exceed 10' (3 m) between elbows, a chimney stabilizer must be used at the midpoint. The stabilizer support straps must be attached under tension (in shear) to structural framing members above. When two sets of offset elbows are used, the maximum combined length of chimney used between elbows cannot exceed 20' (6.1 m) (**Figures 35 through 37**). **Example:** If  $C_1 = 10'$  (3 m) then  $C_2$  cannot exceed 10' (3 m).

If an offset exceeds 6' in length, each chimney joint beyond the first 6' of offset to the return elbow, must be secured by a No. 8 x 1/2" sheet metal screw located at the underside of the joint (**Figure 38**).

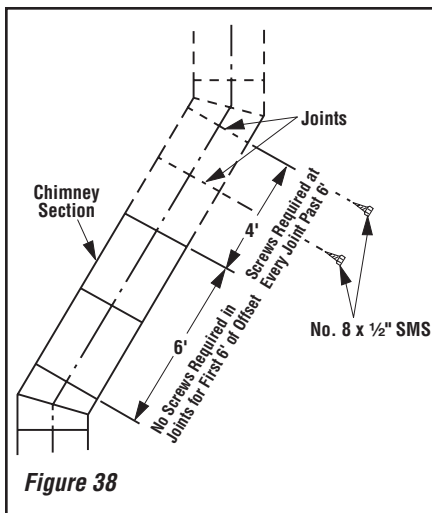

A 1/8" (3 mm) diameter hole must be drilled in the chimney joint using a 1/8" (3 mm) diameter drill. Hole should be drilled in center of joint overlap (**Figure 39**). Be sure to drill only through the outer chimney casting. Do not puncture the inner flue.

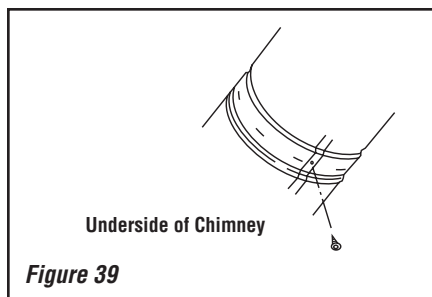

Maximum offset of the chimney system is 30°. Two offset elbows must not be assembled to form a 60° offset. However, two sets of offset and return elbows may be used on a single flue system, provided the total height of the system exceeds 25' (7.6 m).

Return elbow support straps must be securely attached under tension (in shear) to structural framing members above.

### OFFSET CALCULATIONS

1. Use Offset Chart to determine amount of horizontal offset (A) and height (B) for various chimney sections.
2. Use "Height of Chimney Only" column to determine combinations of pipe used above return elbow to achieve desired heights. Reference Components Effective Height Chart in Figure elevation chart section.
3. Use Elevation Chart as job estimator only. Add necessary firestop spacers and stabilizers as required. Firestop spacers must be used as shown in **Figures 20 and 21** and stabilizers as shown in **Figure 27**.

### INSTALLING OFFSETS

First, review Offset Elevation Chart (**Table 3**) and **Figure 34** on **Page 14**.

**Step 1.** Determine the offset distance where chimney is to pass through the first ceiling-dimension "A." To find this point on your ceiling, first determine the center point for a vertical chimney following the instructions for vertical installation.

Measure height to the ceiling from the top of fireplace-dimension "B." Use Offset Elevation Chart to find dimension "A." Mark point where you will drive your nail to show the center point for your offset ceiling cut.

**Step 2.** Proceed by using the Straight Up Installation Instructions for cutting and framing ceiling and roof openings.

**Note:** See "Framing and Dimension" Chart for the sizes of the ceiling and roof openings. The size of the roof opening varies with the degree of pitch of the roof.

### OFFSET ELBOW ASSEMBLY

Offset elbows install the same as chimney sections. First, snap the inner section INTO the preceding inner section of flue. Check connection by pulling up slightly to ensure a tight fit. Next, the outer sections snap locks OVER the preceding outer section of chimney. Again, check outer section by pulling up slightly to ensure proper connection is made.

### RETURN ELBOW ASSEMBLY

Return elbows install the same way as round terminations and stabilizers:

- Step 1.** Hold return elbow over top of last chimney section.
- Step 2.** Center inner slip section into inner flue pipe-slip down.
- Step 3.** Center outer locking section over outer chimney pipe-push down until locking joint has firmly engaged.
- Step 4.** Pull up slightly on return elbow to ensure locking joint has firmly engaged.
- Step 5.** Secure support straps to framing members by nailing under tension in shear (**Figure 40**).

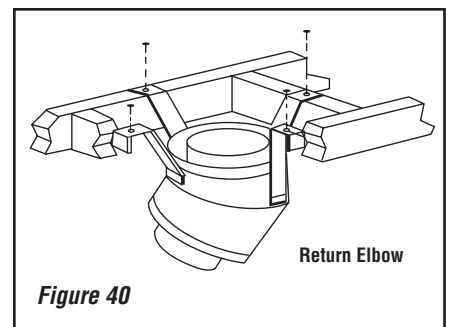

**Note:** The return elbow assembly performs the same function as a stabilizer. Consider this when determining the need for a stabilizer.

**Note:** Do not apply excessive pressure to any subsequent chimney section following return elbow assembly when installing. Ensure subsequent chimney sections are securely attached by testing as noted above.



## CHIMNEY OFFSET 30° THROUGH FLOOR OR CEILING

It may be necessary to assemble the chimney at 30° when passing through the floor or ceiling area. Use the F8FS30-2 firestop spacer as shown in **Figures 41 and 42**.

Support the chimney at floor or ceiling penetration with a FTF8 stabilizer if distance of chimney below ceiling is 10' (3 m) or more. Maintain 2" (51 mm) minimum air space to combustibles from chimney sections. The chimney must pass vertically through the attic space.

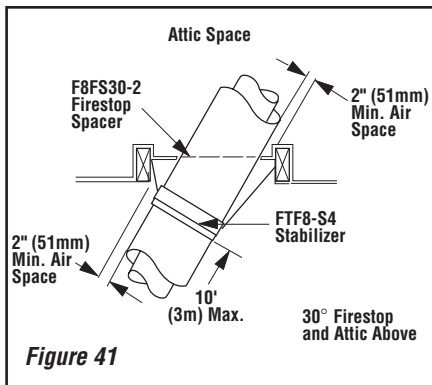

Figure 41

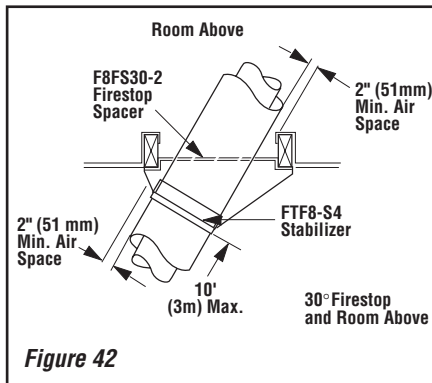

Figure 42

## GLASS DOORS

The Fireplaces require the use of the standard glass doors (provided). The use of any other non-listed door on these fireplaces may result in a potential fire hazard and is not recommended.

Make a careful inspection of all parts before installing the doors to ensure they are undamaged and complete. There will be two (2) glass door assemblies for both sides of the CST38MH fireplace.

### Note:

- Design characteristics of a dual-opening fireplace (whether masonry or factory-built) may cause it to not draft properly and smoke. For this reason, glass doors are required with model CST38MH fireplaces.
- Upper door pivot pins can also be loosened for adjustment purposes; however, it is easier to loosen lower pins.

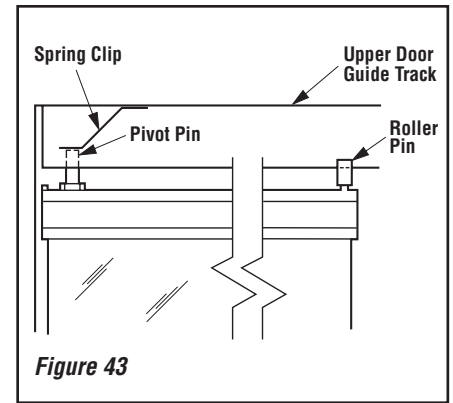
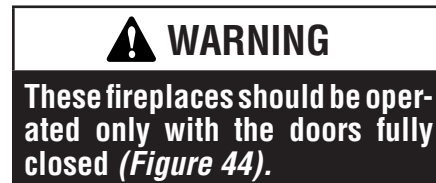

Figure 43

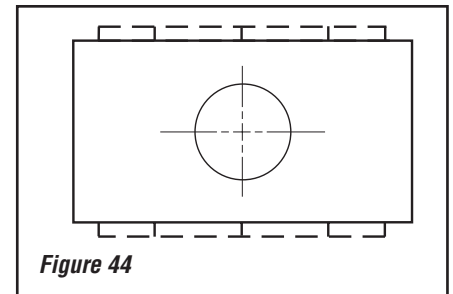
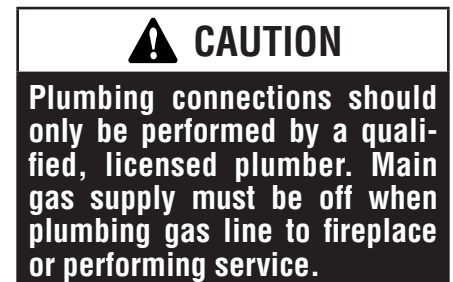

Figure 44

## GAS LINE INSTALLATION

The Fireplaces have been approved to accept a 1/2" (13 mm) gas line for an approved gas appliance. Always have the appliance installed by a qualified, licensed plumber in accordance with all local building codes. The gas line may enter either end of the fireplace.



If you're installing a gas line, connect it before the fireplace is framed and enclosed in the finished wall. The gas knockout is determined by a 1-1/8" (29 mm) round indentation located at the bottom and slightly off center in the side refractories. **THE KNOCKOUT IS ALWAYS REMOVED FROM INSIDE THE FIREPLACE. DO NOT REMOVE THE KNOCKOUT UNLESS YOU ARE INSTALLING A GAS LINE.** If removal is attempted from the outer wrapper, side-refractory damage may occur. With a medium-sized hammer, lightly tap the surface of the indentation. The refractory material is very thin in this area and is easily removed. Once a small hole has been made, continue tapping until you have reached sufficient diameter for the gas line to fit through. The entire knockout does not have to be removed. Remove insulation in the gas line channel.

Install a 1/2" (13 mm) gas supply line through fireplace wall for connection to a decorative gas appliance inside the firebox. Outside, the gas supply line must connect to a gas shut-off valve usually recessed flush into the wall or floor. The valve should be controlled by a removable valve key for safety.

Always plumb gas line installation per local codes. Check all connections using a gas leak test solution (also referred to as bubble leak solution). **Note:** Using a soapy water solution (50% dish soap, 50% water) is an effective leak test solution but it is not recommended, because the soap residue that is left on the pipes/fittings can result in corrosion over time. Never test any gas line connection with a match or open flame.



### IMPORTANT

**Repack insulation material in square hole around gas line, interior and exterior, to seal.**

For all areas, this provision is intended only for connection to a decorative gas appliance incorporating an automatic shut-off device and complying with the standard for Decorative Gas Appliances for installation in vented fireplaces, ANSI Z21.60. Install in accordance with the National Fuel Gas Code, ANSI Z223.1.



### CAUTION

**When using the decorative gas appliance, the fireplace damper must be set in the fully open position.**

## COLD CLIMATE INSULATION

If you live in a cold climate, it is especially important to seal all cracks around the fireplace and wherever cold air could enter the room with noncombustible material. Surround material must be caulked where it meets the black metal facing of the fireplace to avoid cold air intrusion. Use noncombustible caulking material only on fireplace facing to seal. Also, the outside air inlet duct should be wrapped with noncombustible insulation to minimize the formation of condensation. Do not place insulation materials directly against the chimney sections.

**Note:** 2" (51 mm) air space must be preserved for all materials extending for any continuous length adjacent to the chimney.

It is especially important to insulate between the studs of an outside chase cavity and under the floor if the floor is above ground level. Do not place insulation directly against the fireplace or chimney system.

## FIREPLACE FINISHES Mantels and Trim

It is sometimes best to frame your fireplace after it is positioned and the chimney is installed. Frame enclosure for chimney and fireplace with 2 x 4's (or heavier) lumber.

**Note:** The header may rest on the two (2) metal top spacers on top of the unit but the header must not be notched to fit around the spacers.

In all installations, combustible mantels and trim may be installed 12" (305mm) above the opening as per NFPA 211-latest edition, and **Figure 45**. If a mantel is of a noncombustible material, it is exempt from the requirements as long as it does not interfere with the operation of glass doors.

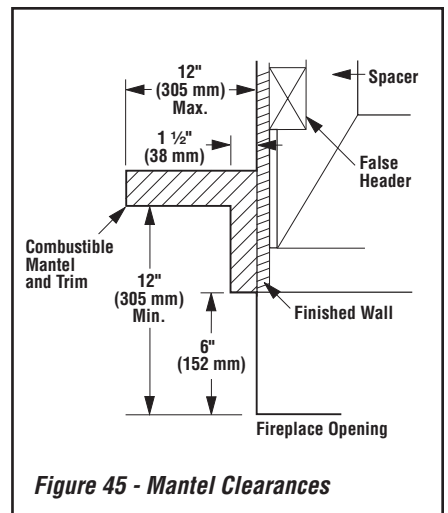

**Figure 45 - Mantel Clearances**

## Hearth Extensions and Wall Shields

A hearth extension must be installed with all fireplaces. Its purpose is twofold. It protects a combustible floor in front of the fireplace from both radiant heat and sparks and it distinguishes the prescribed hearth extension area from other non-protected surfaces.

The hearth extension must extend beyond the front and both sides of the fireplace side openings. Use a hearth extension constructed of a durable noncombustible material having an equal or better (lower k value) insulating value of  $k = .84 \text{ BTU IN/FT}^2 \text{ HR } ^\circ\text{F}$  or a thermal resistance that equals or exceeds  $r = 1.19 \text{ HR } ^\circ\text{F FT}^2/\text{BTU IN}$ . A minimum 3/8" (10 mm) thick noncombustible material is all that is required over a noncombustible or slab floor.

If there is a continuous perpendicular side wall closer than 18" (mm) from the fireplace opening, it must be protected with a 40" x 40" x 1/2" (1016 mm x 1016 mm x 13 mm) wall shield (see **Figure 46**) constructed of a durable, noncombustible material having an equal or better (lower k value) insulating value than  $k = .84 \text{ BTU IN/FT}^2 \text{ HR } ^\circ\text{F}$ . A continuous protected side wall can not be closer than 8" (203 mm) from the fireplace opening.

Secure the hearth extension to the floor to prevent possible shifting.

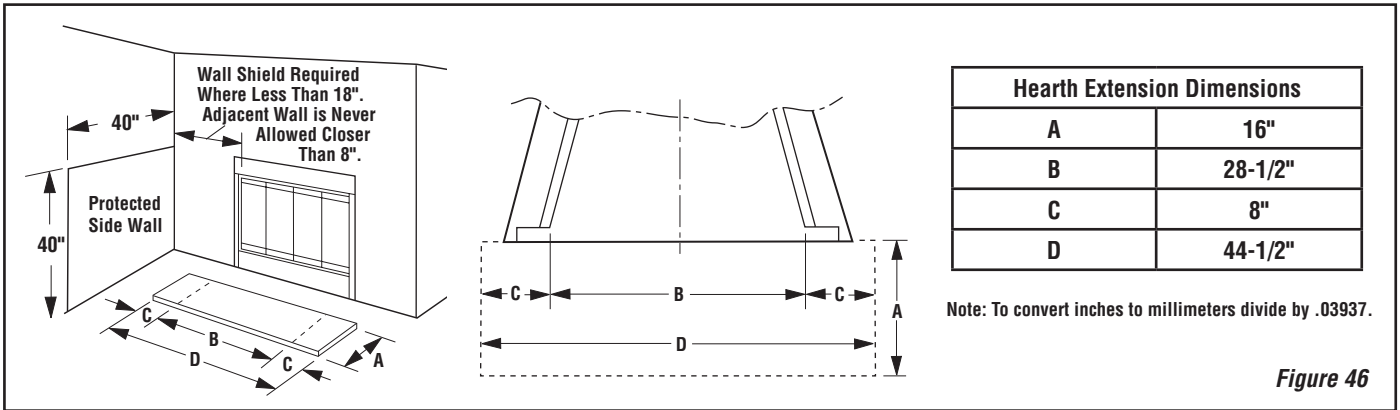

**Methods of Determining Hearth Extension and Wall Shield**

**Equivalents** - To determine the thickness required for the alternate material when either the "k" value or "r" value is known, use either the **k formula** or **r formula**.

**Example:** If Micore 160 is to be used for the hearth extension fireplace, how thick must this material be?

- $k_M$  = k value per inch of *alternate* material
- $r_M$  = r value per inch of *alternate* material
- $T_M$  = minimum thickness required for *alternate* material
- $T_S$  = standard thickness of the *alternate* material
- $k_L$  = k value per inch of *listed* material
- $r_L$  = r value per inch of *listed* material
- $T_L$  = minimum thickness of *listed* material

**Note:** An asterix "\*" indicates, it is a value taken from **Table 5**.  
**Using the k formula:**

Minimum thickness of alternate material ( $T_M$ )	=	$\frac{k\text{-value (per Inch) of alternate material } (k_M)}{k\text{-value (per inch) of listed material } (k_L)}$	x	Specified min. thickness of listed material ( $T_L$ )
$T_M$ (inches)	=	$\frac{.84}{*.84}$	x	$T_L$
$T_M$ (inches)	=	$\frac{*.35}{*.84}$	x	1"
.416 (inches)=		.416	x	1"

**Answer -** The minimum required thickness of the Micore 160 is .417, "therefore round up to nearest standard thickness available which is 1/2."

**Using the r formula:**

Minimum thickness of alternate material	=	$\frac{r\text{-value (per Inch) of listed material}}{r\text{-value (per inch) of alternate material}}$	x	Specified min. thickness of listed material
$T_M$ (inches)	=	$\frac{r_L}{r_M}$	x	$T_L$
$T_M$ (inches)	=	$\frac{*.19}{*2.86}$	x	1"
.417 (inches)=		.416	x	1"

**Answer -** The minimum required thickness of the Micore 160 is .417, "therefore round up to nearest standard thickness available which is 1/2."

Listed Material			
	k (per inch)	r (per inch)	Listed Min. Thickness
Listed Material	.84 $k_L$	1.19 $r_L$	1" $T_L$
** Approved Alternate Materials for Floor/Hearth Protection			
Alternative Materials	Thermal Values		Minimum Thickness (rounded to nearest 1/8 inch)
	k (per inch) $k_M$	r (per inch) $r_M$	Min. Thickness $T_M$
Kaowool M Board	.47	2.13	.56" (1/2")
Micore 160™ U.S. Gypsum	.35	2.86	.42" (3/8")
Micore 300™ U.S. Gypsum	.46	2.17	.55" (1/2")
Durock™ Cement Board U.S. Gypsum	1.92	.52	2.29" (2-1/4")
Hardibacker™	1.95	.513	2.32" (2-3/8")
Hardibacker 500™	2.30	.435	2.74" (2-3/4")
Cultered Stone Hearth-stone™	2.82	.355	3.36" (3-3/8")
Wonderboard	3.23	.31	3.85" (3-7/8")
Super Firetemp M Johns-Manville	.61	1.64	.73" (3/4")
Super Firetemp L Johns-Manville	.54	1.85	.64" (5/8")
Face brick	9.00	.111	10.71" (10-3/4")
Common brick	5.00	.20	5.95" (6")
Cement mortar	5.00	.20	5.95" (6")
Ceramic tile	12.5	.08	14.88" (14-7/8")
Marble	~11	~.09	13.10" (13-1/8")

**Table 5**

\*\* If the hearth extension material(s) that is intended to be used is NOT listed on Table 5, the material can still be used if the material(s) is noncombustible. However, the manufacturer of the material must provide either the listed k-value per inch or r-value per inch with listed thickness so that the minimum thickness required for the hearth can be calculated (per instructions on this Page and/or as specified in the NFI Certification manuals).

Note: Also see NFI (National Fireplace Institute) Certification Manuals showing other acceptable calculation methods and acceptable alternate materials which can be used.

## Calculating Minimum Thickness if Multiple Materials are Used

At times it is important to know what combination of materials are acceptable for use as floor protection. The "R values" are used to determine acceptable combinations of materials because "R values" are additive where r and k values are not.

"R value" =  $1/k$  = "r" x thickness of material used

**Example:** Given that the required "R value" for a suitable floor protector used must be equal to or greater than:

$$"R" = r_L \times T_L = 1.19 \times 1" = 1.19."$$

If it is desired to elevate a marble hearth extension to a level of 5" or more above the floor surface. What combination of noncombustible materials can be used to accomplish this?

If common brick is used so that the 3-1/2" dimension is the height, "R" for the common brick becomes:

$$"R"_{\text{M}} = r_{\text{M}} \times T_{\text{S}} = \overset{\text{brick}}{0.20} \times 3\text{-}1/2" = .70$$

Using 1/2" of mortar to set the brick, "R" for the mortar is calculated as follows:

$$"R"_{\text{M}} = r_{\text{M}} \times T_{\text{S}} = \overset{\text{mortar}}{0.20} \times 1/2" = .10$$

Next, a 3/4" marble slab set in 1/2" mortar covers the brick, "R" for the marble and mortar becomes:

$$"R"_{\text{M}} = r_{\text{M}} \times T_{\text{S}} = \overset{\text{marble}}{0.05} \times 3/4" = .038$$

$$"R"_{\text{M}} = r_{\text{M}} \times T_{\text{S}} = \overset{\text{mortar}}{0.20} \times 1/2" = .10$$

The sum of all "R values" is: .70 + .10 + .038 + .10 = .938

This would NOT be an acceptable combination of material for the hearth extension since the total calculated "R value" of the materials used is under the required "R value" of 1.19. An additional layer of insulating materials must be used.

**Note:** Also see NFI Certification Manuals for expanded explanation on calculating "R values" when multiple materials are used.

## WARNING

The crack between the fireplace and the hearth extension must be sealed with a noncombustible material.

## WARNING

When installing hearth extension in front of a non-circulating fireplace model, the fireplace must be raised if height of hearth extension exceeds 5-3/4" above the bottom of fireplace (Figure 47).

When installing the hearth extension be careful not to block the heat-circulating air inlet grill on circulating models.

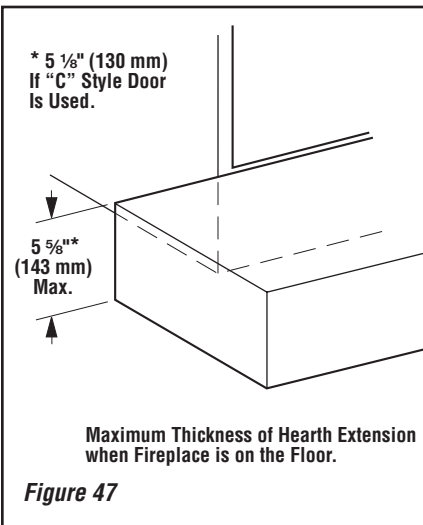

## FINISH TO YOUR TASTE

There are a wide variety of "finished looks" for your Fireplace from formal wall decor with elaborate mantels to rustic wood paneling or warm brick facings.

Only noncombustible materials like marble, stone, tile, brick, etc. may overlap the black front facing, but be careful not to interfere with the operation of the glass doors. Seal all joints between the black facing and wall surrounds to prevent cold air intrusion. Use noncombustible caulking material only to seal the black metal facing to the surround material on the finished wall.

Combustibles may also project beyond the sides of the fireplace opening as long as they are kept within the shaded areas, as illustrated in Figure 48.

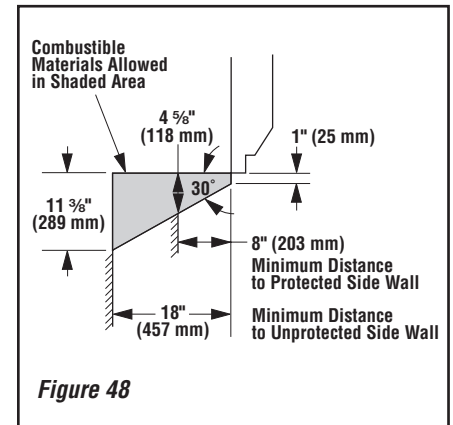

## ACCESSORY PARTS AND COMPONENTS LIST FOR MODEL CST38MH

The accessory parts and components shown on Pages 21 and 22 are to be used only with your CST-38MH fireplace system. Separate installation instructions are packaged with all combustion air kits and chimney terminations.

If you encounter any problems or have questions concerning the installation or application of this system, please contact your distributor. For the name of your nearest distributor, please call 1-800-953-6669.

**LHP**  
**1110 West Taft Avenue**  
**Orange, CA 92865**

# INSTALLATION COMPONENTS



	63L10	FTF8-12
	63L13	FTF8-18
	H0522	FTF8-24
	63L14	FTF8-36
<b>Chimney Section</b>	63L15	FTF8-48

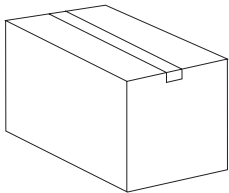

<b>Adjustable Chimney Pipe Kits</b>		
	H0560	FM8-PK20

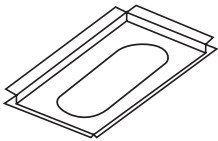

<b>Firestop Spacer (30°) 2"</b>	63L32	F8FS30-2
---------------------------------	-------	----------

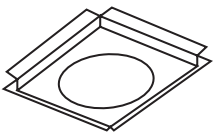

<b>Firestop Spacer (Flat) (Single Pack)</b>	63L31	F8FS-2
<b>Firestop Spacer (Flat) (12 Pack)</b>	94L76	F8FS-12

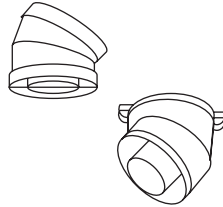

<b>Offset/ Return Package</b>		
<b>30 Degree Offset/Return Elbow</b>	FTF8-ES30	63L22
<b>15 Degree Offset/Return Elbow</b>	FTF8-OR15	63L28

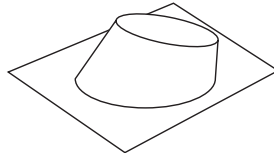

	19M55	F8F6MH
	19M56	F8F12MH
	63L38 (0-6/12)	F8F6
<b>Flashing</b>	63L39 (6/12-12/12)	F8F12

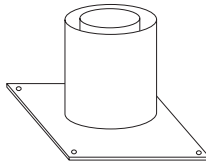

<b>Adjustable Firestop/Thimble H0326 FM8-AT2</b>		
--	--	--

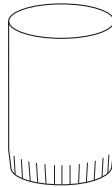

<b>Thimble Extension 2"</b>	19M52	F8-TE26-2
-----------------------------	-------	-----------

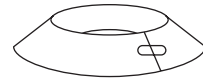

<b>Storm Collar</b>	63L59	FSC
<b>Storm Collar (12 pack)</b>	94L77	FSC-B-12

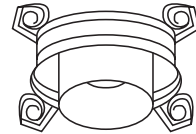

<b>Stabilizer</b>	63L25	FTF8-S4
-------------------	-------	---------

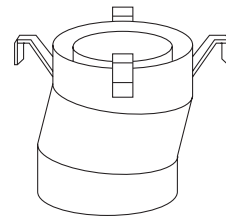

Ref. Form #750,012M

<b>Combination Offset/Return Elbow</b>	63L28	FTF8-OR15
--	-------	-----------

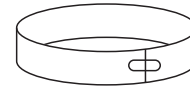

Ref. Form #750,080M

<b>Locking Band</b>	63L60	FLB
---------------------	-------	-----

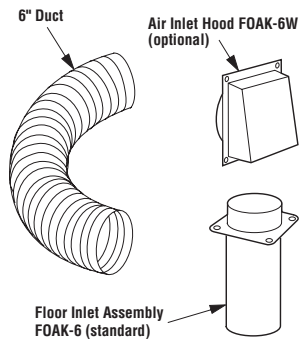

<b>Outside Air Kit (optional)</b>	19M17	FOAK-6W
<b>Outside Air Kit (standard)</b>	90L83	FOAK-6

NOTE: DIAGRAMS & ILLUSTRATIONS ARE NOT TO SCALE.

**ACCESSORIES AND COMPONENTS**

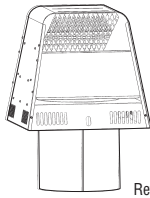

Ref. Form #750,036M

**Arch Type Termination      96L22      FTF8-ATT**

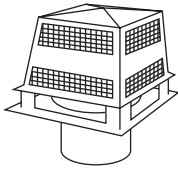

Ref. Form #750,015M

**Chase Termination - Pyramid (Square)      63L48      FTF8-CT1**  
**Chase Termination - Pyramid, Black (Square)      91L79      FTF8-CT1P**

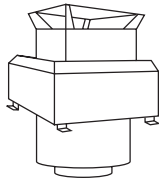

Ref. Form #750,016M

**Chase Termination (Square)      63L51      FTF8-CT2**

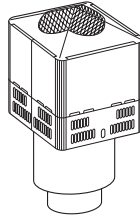

Ref. Form #750,077M

**Chase Termination      96L20      FTF8-CTT**

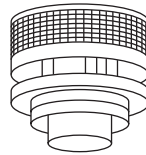

**Contemporary Termination - Round      63L42      FTF8-CTD**  
**Contemporary Termination - Round, Black      H2238      FTF8-CTDP**

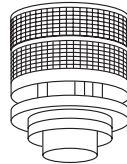

Ref. Form #750,205M

**Chase Termination (Round)      H0203      FTF8-CTDTM**

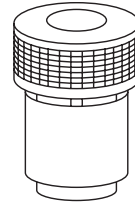

Ref. Form #750,014M

**Chase Termination (Round)      63L45      FTF8-CTDT**

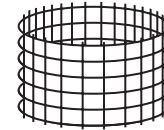

**Spark Arrestor (CT2 Termination)      63L57      FSA-2**

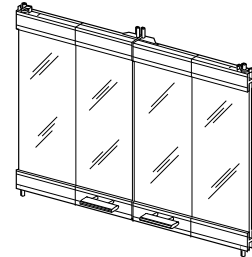

**"All-Glass™" 38" Aluminum Bi-Fold Doors**

**12M07 (Black) Standard      38ABF**  
**12M08 (Brass)      38ABF-BB**  
**12M09 (Brushed Stainless)      38ABF-BS**

**NOTES**

---

The manufacturer reserves the right to make changes at any time, without notice, in design, materials, specifications, prices and also to discontinue colors, styles and products. Consult your local distributor for fireplace code information.