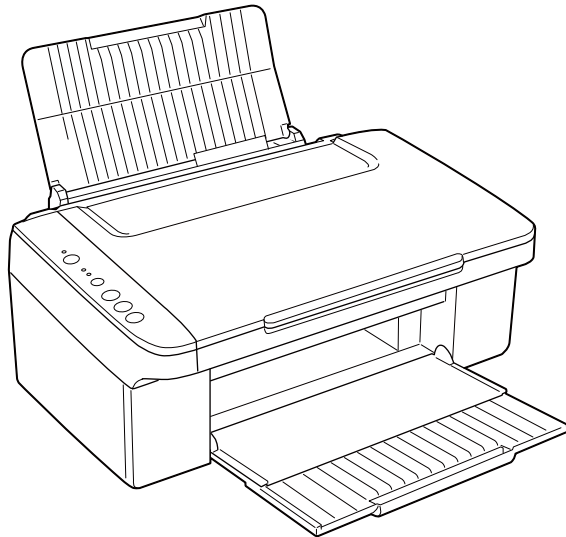


SERVICE MANUAL



Color Inkjet Printer

**EPSON Stylus NX100/NX105/SX100/
SX105/TX100/TX101/TX102/
TX103/TX105/TX106/TX109/
ME 300**

Notice:

- All rights reserved. No part of this manual may be reproduced, stored in a retrieval system, or transmitted in any form or by any means, electronic, mechanical, photocopying, recording, or otherwise, without the prior written permission of SEIKO EPSON CORPORATION.
- The contents of this manual are subject to change without notice.
- All effort have been made to ensure the accuracy of the contents of this manual. However, should any errors be detected, SEIKO EPSON would greatly appreciate being informed of them.
- The above notwithstanding SEIKO EPSON CORPORATION can assume no responsibility for any errors in this manual or the consequences thereof.

EPSON is a registered trademark of SEIKO EPSON CORPORATION.

General Notice: Other product names used herein are for identification purpose only and may be trademarks or registered trademarks of their respective owners. EPSON disclaims any and all rights in those marks.

Copyright © 2008 **SEIKO EPSON CORPORATION.**
Imaging Products CS, PL & Environmental Management

PRECAUTIONS

Precautionary notations throughout the text are categorized relative to 1) Personal injury and 2) damage to equipment.

DANGER Signals a precaution which, if ignored, could result in serious or fatal personal injury. Great caution should be exercised in performing procedures preceded by DANGER Headings.

WARNING Signals a precaution which, if ignored, could result in damage to equipment.

The precautionary measures itemized below should always be observed when performing repair/maintenance procedures.

DANGER

1. ALWAYS DISCONNECT THE PRODUCT FROM THE POWER SOURCE AND PERIPHERAL DEVICES PERFORMING ANY MAINTENANCE OR REPAIR PROCEDURES.
2. NO WORK SHOULD BE PERFORMED ON THE UNIT BY PERSONS UNFAMILIAR WITH BASIC SAFETY MEASURES AS DICTATED FOR ALL ELECTRONICS TECHNICIANS IN THEIR LINE OF WORK.
3. WHEN PERFORMING TESTING AS DICTATED WITHIN THIS MANUAL, DO NOT CONNECT THE UNIT TO A POWER SOURCE UNTIL INSTRUCTED TO DO SO. WHEN THE POWER SUPPLY CABLE MUST BE CONNECTED, USE EXTREME CAUTION IN WORKING ON POWER SUPPLY AND OTHER ELECTRONIC COMPONENTS.
4. WHEN DISASSEMBLING OR ASSEMBLING A PRODUCT, MAKE SURE TO WEAR GLOVES TO AVOID INJURIES FROM METAL PARTS WITH SHARP EDGES.

WARNING

1. REPAIRS ON EPSON PRODUCT SHOULD BE PERFORMED ONLY BY AN EPSON CERTIFIED REPAIR TECHNICIAN.
2. MAKE CERTAIN THAT THE SOURCE VOLTAGES IS THE SAME AS THE RATED VOLTAGE, LISTED ON THE SERIAL NUMBER/RATING PLATE. IF THE EPSON PRODUCT HAS A PRIMARY AC RATING DIFFERENT FROM AVAILABLE POWER SOURCE, DO NOT CONNECT IT TO THE POWER SOURCE.
3. ALWAYS VERIFY THAT THE EPSON PRODUCT HAS BEEN DISCONNECTED FROM THE POWER SOURCE BEFORE REMOVING OR REPLACING PRINTED CIRCUIT BOARDS AND/OR INDIVIDUAL CHIPS.
4. IN ORDER TO PROTECT SENSITIVE MICROPROCESSORS AND CIRCUITRY, USE STATIC DISCHARGE EQUIPMENT, SUCH AS ANTI-STATIC WRIST STRAPS, WHEN ACCESSING INTERNAL COMPONENTS.
5. REPLACE MALFUNCTIONING COMPONENTS ONLY WITH THOSE COMPONENTS BY THE MANUFACTURE; INTRODUCTION OF SECOND-SOURCE ICs OR OTHER NON-APPROVED COMPONENTS MAY DAMAGE THE PRODUCT AND VOID ANY APPLICABLE EPSON WARRANTY.
6. WHEN USING COMPRESSED AIR PRODUCTS; SUCH AS AIR DUSTER, FOR CLEANING DURING REPAIR AND MAINTENANCE, THE USE OF SUCH PRODUCTS CONTAINING FLAMMABLE GAS IS PROHIBITED.

About This Manual

This manual describes basic functions, theory of electrical and mechanical operations, maintenance and repair procedures of the printer. The instructions and procedures included herein are intended for the experienced repair technicians, and attention should be given to the precautions on the preceding page.

Manual Configuration

This manual consists of six chapters and Appendix.

CHAPTER 1.PRODUCT DESCRIPTIONS

Provides a general overview and specifications of the product.

CHAPTER 2.OPERATING PRINCIPLES

Describes the theory of electrical and mechanical operations of the product.

CHAPTER 3.TROUBLESHOOTING

Describes the step-by-step procedures for the troubleshooting.

CHAPTER 4.DISASSEMBLY / ASSEMBLY

Describes the step-by-step procedures for disassembling and assembling the product.

CHAPTER 5.ADJUSTMENT

Provides Epson-approved methods for adjustment.

CHAPTER 6.MAINTENANCE

Provides preventive maintenance procedures and the lists of Epson-approved lubricants and adhesives required for servicing the product.

APPENDIX Provides the following additional information for reference:

- Exploded Diagram
- Parts List

Symbols Used in this Manual

Various symbols are used throughout this manual either to provide additional information on a specific topic or to warn of possible danger present during a procedure or an action. Be aware of all symbols when they are used, and always read NOTE, CAUTION, or WARNING messages.



Indicates an operating or maintenance procedure, practice or condition that is necessary to keep the product's quality.



Indicates an operating or maintenance procedure, practice, or condition that, if not strictly observed, could result in damage to, or destruction of, equipment.



May indicate an operating or maintenance procedure, practice or condition that is necessary to accomplish a task efficiently. It may also provide additional information that is related to a specific subject, or comment on the results achieved through a previous action.



Indicates an operating or maintenance procedure, practice or condition that, if not strictly observed, could result in injury or loss of life.



Indicates that a particular task must be carried out according to a certain standard after disassembly and before re-assembly, otherwise the quality of the components in question may be adversely affected.

Revision Status

Revision	Date of Issue	Description
A	June 27, 2008	First Release

Contents

Chapter 1 PRODUCT DESCRIPTION

1.1 Features.....	9
1.2 Printing Specifications.....	10
1.2.1 Basic Specifications.....	10
1.2.2 Ink Cartridge.....	10
1.2.3 Print Mode.....	11
1.2.4 Supported Paper.....	12
1.2.5 Printing Area.....	14
1.3 Scanner Specifications.....	14
1.3.1 Scanning Range.....	14
1.4 General Specifications.....	15
1.4.1 Electrical Specifications.....	15
1.4.2 Environmental Conditions.....	15
1.4.3 Durability.....	16
1.4.4 Acoustic Noise.....	16
1.4.5 Safety Approvals (Safety standards/EMI).....	16
1.5 Interface.....	16
1.5.1 USB Interface.....	16
1.6 Control Panel.....	17
1.6.1 Operation Buttons & LEDs.....	17
1.6.2 Control Panel Functions.....	18
1.7 Stand-alone Copy Function.....	21
1.7.1 Supported Paper and Copy Mode.....	21
1.7.2 Setting for Stand-alone Copy.....	21
1.7.3 Copy Speed.....	22
1.7.4 Multiple Copying.....	22

Chapter 2 OPERATING PRINCIPLES

2.1 Overview.....	24
2.1.1 Printer Mechanism.....	24
2.1.2 Motors & Sensors.....	25
2.1.3 Printhead.....	26

Chapter 3 TROUBLESHOOTING

3.1 Overview.....	28
3.1.1 Specified Tools.....	28
3.1.2 Preliminary Checks.....	28
3.2 Error Indications and Fault Occurrence Causes.....	29
3.2.1 Troubleshooting by Error Message.....	30
3.2.2 Superficial Phenomenon-Based Troubleshooting.....	46
3.2.3 Motor and Sensor Troubleshooting.....	53

Chapter 4 DISASSEMBLY/ASSEMBLY

4.1 Overview	55
4.1.1 Precautions	55
4.1.2 Tools	55
4.1.3 Work Completion Check	56
4.2 Disassembly Procedures	57
4.3 Removing the Housing	58
4.3.1 Paper Support Tray	58
4.3.2 Stacker Assy	58
4.3.3 Document Cover/ASF Cover	59
4.3.4 Scanner Stand /Cover Wire	60
4.3.5 Scanner Unit	62
4.3.6 Middle Housing	63
4.4 Removing the Circuit Boards	64
4.4.1 Panel Unit	64
4.4.2 Main Board	65
4.4.3 Power Supply Unit	66
4.5 Disassembling the Printer Mechanism	68
4.5.1 Printhead	68
4.5.2 CR Scale	71
4.5.3 Hopper	72
4.5.4 PF Encoder/ PF Scale	73
4.5.5 EJ Roller/ EJ Frame Assy	73
4.5.6 CR Motor/ Driven Pulley	75
4.5.7 Ink System	77
4.5.8 PF Motor	82
4.5.9 Main Frame	84
4.5.10 Upper Paper Guide	86
4.5.11 CR Unit	87
4.5.12 PF Roller	90
4.5.13 LD Roller/ ASF Unit	91
4.5.14 Waste Ink Pads	93
4.6 Disassembling the Scanner Unit	96
4.6.1 Upper Scanner Housing	96
4.6.2 Scanner Carriage Unit	97
4.6.3 Scanner Motor Unit	99

Chapter 5 ADJUSTMENT

5.1 Adjustment Items and Overview	101
5.1.1 Servicing Adjustment Item List (TBD)	101
5.1.2 Required Adjustments (TBD)	103
5.2 Using the Adjustment Program (TBD)	105
5.2.1 TOP Margin Adjustment	105
5.2.2 First Dot Position Adjustment	105
5.2.3 Head Angular Adjustment	106
5.2.4 Bi-D Adjustment	106
5.2.5 PF Adjustment	107

Chapter 6 MAINTENANCE

6.1 Overview	109
6.1.1 Cleaning	109
6.1.2 Service Maintenance	109
6.1.3 Lubrication	110

Chapter 7 APPENDIX

7.1 Exploded Diagram / Parts List	113
---	-----

CHAPTER

1

PRODUCT DESCRIPTION

1.1 Features

Epson STYLUS NX100/NX105/SX100/SX105/TX100/TX101/TX102/TX103/TX105/TX106/TX109/ME 300 are entry class color ink-jet printers with the scanner function.

□ Features

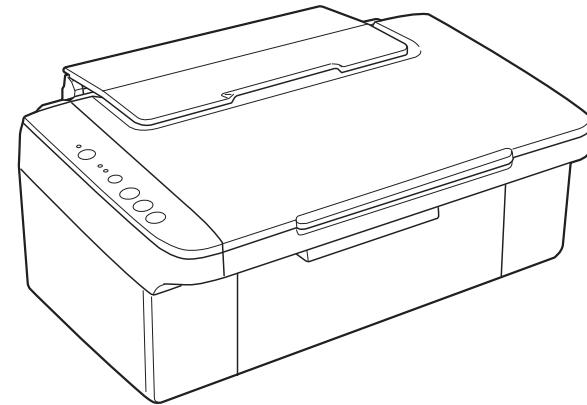
- Maximum print resolution: 5760 (H) x 1440 (V) dpi
- D2 Chips printhead
(Black: 90 nozzles x 1, Color: 29 nozzles x 3 per color)
- Borderless printing with pigment ink
- Four independent ink cartridges is installed.

□ Dimensions

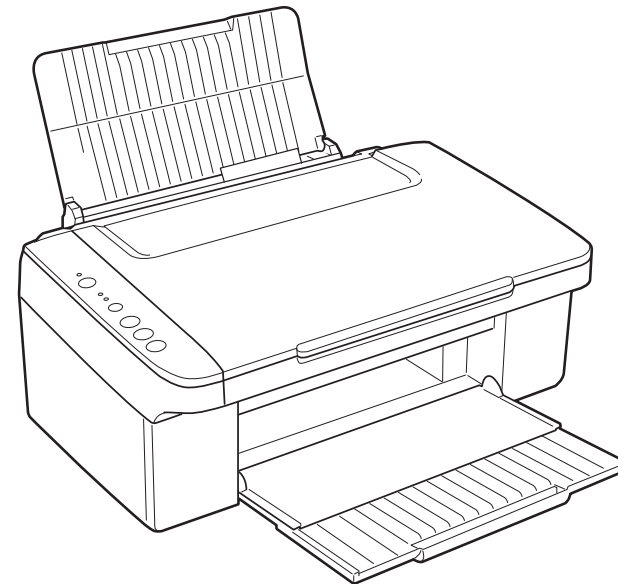
- Dimensions*¹: 434 mm (W) x 327 mm (D) x 185 mm (H)
- Weight*²: 4.45 kg

Note *1: Paper support and stacker are closed. Rubber feet are included.

*2: Excluding the weight of ink cartridges and power cable.



Paper Support & Stacker are Closed



Paper Support & Stacker are Opened

Figure 1-1. External View

1.2 Printing Specifications

1.2.1 Basic Specifications

Table 1-1. Printer Specifications

Item	Specification
Print method	On-demand ink jet
Nozzle configuration	Black: 90 nozzles x 1 Color: 29 nozzles x 3 (Cyan, Magenta, Yellow)
Print direction	Bi-directional minimum distance printing, Unidirectional printing
Maximum print resolution	5760 x 1440 (dpi) MGA
Print resolution	Horizontal x Vertical (dpi) <ul style="list-style-type: none"> • 360 x 120 • 720 x 720 • 360 x 360 • 1440 x 720 • 360 x 720 • MGA 5760 x 1440
Control code	<ul style="list-style-type: none"> • ESC/P Raster command • EPSON Remote command
Input buffer size	32 Kbytes
Paper feed method	Friction feed, using the ASF (Auto Sheet Feeder)
Paper path	Top feed, front out
Paper feed rates	T.B.D. mm/sec (at 25.4 mm feed)
PF interval	T.B.D.

1.2.2 Ink Cartridge

The product numbers of the EPSON ink cartridges for this printer are shown below.

Table 1-2. Product No. of Ink Cartridges

Color	EAI	Latin 1	Latin 2	Euro (West)	CISMEA	Asia 1*1	Asia 2*2	ECC
Black	T0691 T0881	T0731N T0901N	T1161 T1171	T0711 T0891	T0921N	T0731N T0911N	T0731N T0911N	T1091
Cyan	T0692 T0882	T0732N	T0732N	T0712 T0892	T0922N	T0732N T0912N	T0732N T0912N	T1092
Magenta	T0693 T0883	T0733N	T0733N	T0713 T0893	T0923N	T0733N T0913N	T0733N T0913N	T1093
Yellow	T0694 T0884	T0734N	T0734N	T0714 T0894	T0924N	T0734N T0914N	T0734N T0914N	T1094

Note *1: ETT/EKL(WS)/EKL(Other)/EKL(LFR)/EHK/ESP/ESP(Phil)/EAL

*2: ESP(India)/ESP(Inter)

Shelf life

Two years from production date (if unopened), six months after opening package.

Storage Temperature

Table 1-3. Storage Temperature

Situation	Storage Temperature	Limit
When stored in individual boxes	-20 °C to 40 °C (-4°F to 104°F)	1 month max. at 40 °C (104°F)
When installed in main unit	-20 °C to 40 °C (-4°F to 104°F)	

Dimension

12.7 mm (W) x 68 mm (D) x 47 mm (H)



- Do not use expired ink cartridges.
- The ink in the ink cartridge freezes at -16 °C (3.2 °F). It takes about three hours under 25 °C (77°F) until the ink thaws and becomes usable.

1.2.3 Print Mode

Table 1-4. Print Mode (Color)

Media	Print Mode	Resolution (H x V dpi)	Dot Size (cps*)
Plain paper	Fast Economy/ Economy	360x120	Eco (360cps)
	Normal	360x360	VSD1 (165cps)
	Fine	360x720	VSD2' (240cps)
	Photo	720x720	VSD3' (240cps)
	Photo	720x720	VSD2 (240cps)
Photo Quality Inkjet Paper	Best Photo	1440x720	VSD3 (240cps)
	Photo	720x720	VSD2 (240cps)
Matte Paper Heavy-weight	Best Photo	1440x720	VSD3 (240cps)
	Photo	720x720	VSD2 (240cps)
Premium Glossy Photo Paper Glossy Photo Paper Premium Semigloss Photo Paper	Super Fine	360x720	VSD2 (240cps)
	Photo	720x720	VSD2 (240cps)
	Best Photo	1440x720	VSD3 (240cps)
	Photo RPM	5760x1440 MGA	VSD3 (240cps)
Ultra Glossy Photo Paper	Best Photo	1440x720	VSD3 (240cps)
	Photo RPM	5760x1440 MGA	VSD3 (240cps)
Envelope	Normal	360x360	VSD1 (165cps)
	Fine	360x720	VSD2' (240cps)

Note * : cps = character per second

Table 1-5. Print Mode (Monochrome)

Media	Print Mode	Resolution (H x V dpi)	Dot Size (cps*)
Plain paper	Fast Economy/ Economy	360x120	Eco (360cps)
	Normal	360x360	VSD1 (165cps)
	Fine	720x720	VSD2' (240cps)
	Photo	1440x720	VSD3' (240cps)
Photo Quality Inkjet Paper	Photo	720x720	VSD2 (240cps)
	Best Photo	1440x720	VSD3 (240cps)
Matte Paper Heavy-weight	Photo	720x720	VSD2 (240cps)
	Best Photo	1440x720	VSD3 (240cps)
Envelope	Normal	360x360	VSD1 (165cps)
	Fine	720x720	VSD2' (240cps)

Note * : cps = character per second

1.2.4 Supported Paper

The table below lists the paper type and sizes supported by the printer. The supported paper type and sizes vary depending on destinations (between EAI, EUR, and Asia).

Table 1-6. Supported Paper

Paper Name	Paper Size		Thickness (mm)	Weight	EAI		EUR		Asia		
					P*1	B*2	P*1	B*2	P*1	B*2	
Plain paper	Legal	215.9 x 355.6 mm (8.5"x14")	0.08-0.11	64-90 g/m ² (17-24 lb.)	Y	-	Y	-	Y	-	
	Letter	215.9 x 279.4 mm (8.5"x11")			Y	-	Y	-	Y	-	
	A4	210 x 297 mm (8.3"x11.7")			Y	-	Y	-	Y	-	
	B5	182 x 257 mm (7.2"x10.1")			-	-	Y	-	Y	-	
	A5	148 x 210 mm (5.8"x8.3")			-	-	Y	-	Y	-	
	Half Letter	139.7 x 215.9 mm (5.5"x8.5")			Y	-	-	-	-	-	
	A6	105 x 148 mm (4.2"x5.8")			Y	-	Y	-	Y	-	
	User Defined	89 x 127- 329 x 1117.6 mm (3.56"x 5.08" - 13.16"x44.7")			Y	-	Y	-	Y	-	
Premium Inkjet Plain Paper	A4	210 x 297 mm (8.3"x11.7")	0.11	80 g/m ² (21 lb.)	-	-	Y	-	Y	-	
Premium Bright White Paper (EAI)	Letter	215.9 x 279.4 mm (8.5"x11")	0.11	90 g/m ² (24 lb.)	Y	-	-	-	-	-	
Bright White Inkjet Paper (Euro, Asia)	A4	210 x 297 mm (8.3"x11.7")	0.13	92.5 g/m ² (25 lb.)	-	-	Y	-	Y	-	
Ultra Premium Glossy Photo Paper (EAI) Ultra Glossy Photo Paper (Euro, Asia)	Letter	215.9 x 279.4 mm (8.5"x11")	0.30	290 g/m ² (77 lb.)	Y	Y	Y	-	Y	-	
	A4	210 x 297 mm (8.3"x11.7")			Y	Y	Y	Y	Y	Y	Y
	8" x 10"	203.2 x 254 mm			Y	Y	Y	-	Y	-	
	5" x 7"	127 x 178 mm			Y	Y	Y	Y	Y	Y	
	4" x 6"	101.6 x 152.4 mm			Y	Y	Y	Y	Y	Y	
	3.5" x 5"	89 x 127 mm			Y	Y	Y	Y	Y	Y	
Premium Photo Paper Glossy (EAI) Premium Glossy Photo Paper (Euro, Asia)	Letter	215.9 x 279.4 mm (8.5"x11")	0.27	255 g/m ² (68 lb.)	Y	Y	Y	-	Y	-	
	A4	210 x 297 mm (8.3"x11.7")			Y	Y	Y	Y	Y	Y	
	8" x 10"	203.2 x 254 mm			Y	Y	Y	-	Y	-	

Table 1-6. Supported Paper

Paper Name	Paper Size		Thickness (mm)	Weight	EAI		EUR		Asia	
					P*1	B*2	P*1	B*2	P*1	B*2
Photo Paper Glossy (EAI) Glossy Photo Paper (Euro, Asia)	5" x 7"	127 x 178 mm	0.27	255 g/m ² (68 lb.)	Y	Y	Y	Y	Y	Y
	4" x 6"	101.6 x 152.4 mm			Y	Y	Y	Y	Y	Y
	16:9 wide	101.6 x 180.6 mm			Y	Y	Y	Y	Y	Y
	3.5" x 5"	89 x 127 mm			Y	Y	Y	Y	Y	Y
Photo Paper Glossy (EAI) Glossy Photo Paper (Euro, Asia)	Letter	215.9 x 279.4 mm (8.5"x11")	0.25	258 g/m ² (68 lb.)	Y	Y	Y	-	Y	-
	A4	210 x 297 mm (8.3"x11.7")			Y	Y	Y	Y	Y	Y
	5" x 7"	127 x 178 mm			-	-	Y	Y	Y	Y
	4" x 6"	101.6 x 152.4 mm			Y	Y	Y	Y	Y	Y
Premium Photo Paper Semi-Gloss (EAI) Premium Semigloss Photo Paper (Euro, Asia)	Letter	215.9 x 279.4 mm (8.5"x11")	0.27	250 g/m ² (66 lb.)	Y	Y	Y	-	Y	-
	A4	210 x 297 mm (8.3"x11.7")			Y	Y	Y	Y	Y	Y
	4" x 6"	101.6 x 152.4 mm			Y	Y	Y	Y	Y	Y
Photo Paper	A4	210 x 297 mm (8.3"x11.7")	0.24	190 g/m ² (51 lb.)	-	-	Y	Y	Y	Y
	5" x 7"	127 x 178 mm			-	-	Y	Y	-	-
	4" x 6"	101.6 x 152.4 mm			-	-	Y	Y	Y	Y
Premium Presentation Paper Matte (EAI) Matte Paper-Heavyweight (Euro, Asia)	Letter	215.9 x 279.4 mm (8.5"x11")	0.23	167 g/m ² (44 lb.)	Y	Y	Y	-	Y	-
	A4	210 x 297 mm (8.3"x11.7")			Y	Y	Y	Y	Y	Y
	8" x 10"	203.2 x 254 mm			Y	Y	-	-	-	-
Photo Quality Inkjet Paper	A4	210 x 297 mm (8.3"x11.7")	0.13	102 g/m ² (27 lb.)	-	-	Y	-	Y	-
Envelopes	#10	104.8 x 241.3 mm (4.125"x9.5")	-	75-100 g/m ² (20-27 lb.)	Y	-	Y	-	Y	-
	#DL	110 x 220 mm			-	-	Y	-	Y	-
	#C6	114 x 162 mm			-	-	Y	-	Y	-

Note *1: "Y" in the "P" column stands for "the paper type/size is Supported".

*2: "Y" in the "B" column stands for "Borderless printing is available".



- Make sure the paper is not wrinkled, fluffed, torn, or folded.
- The curve of paper must be 5 mm or below.
- When printing on an envelope, be sure the flap is folded neatly.
- Do not use the adhesive envelopes.
- Do not use double envelopes and cellophane window envelopes.

1.2.5 Printing Area

The printing area for this printer is shown below.

Table 1-7. Printing Area (Margins)

Print Mode	Paper Size	Margin			
		Left	Right	Top	Bottom
Standard print	Any size	3 mm	3 mm	3 mm	3 mm
	Envelope	5 mm	5 mm	3 mm	20 mm
Borderless print	A4 / Letter to 5" x 7"	2.54 mm*	2.54 mm*	2.96 mm*	4.02 mm*
	4" x 6" / 3.5" x 5"			2.82 mm*	3.60 mm*

Note *: The margins for Borderless print are margins that bleed off the edges of paper.

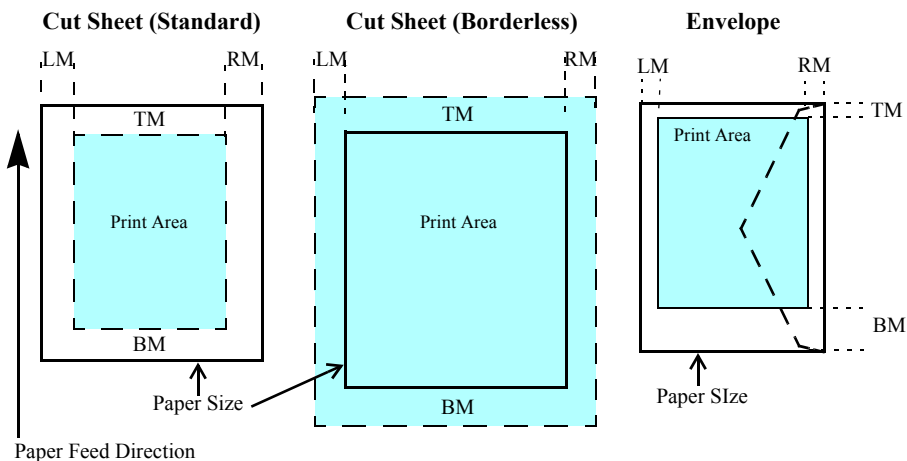


Figure 1-2. Printing Area

1.3 Scanner Specifications

Table 1-8. Basic Specifications

Item	Specification
Scanner type	Flatbed, color
Scanning method	Moving carriage, stationary document
Home position	The front right corner
Photoelectric device	CIS
Light source	LED
Maximum document sizes	A4 or US letter
Scanning range	8.5" x 11.7" (216 mm x 297 mm)
Maximum resolution	Main scan: 600 dpi Sub scan: 1200 dpi
Maximum effective pixels	5,100 x 14,040 pixels (CIS optical resolution x Microstep drive)
Pixel depth	Input: 16 bit each pixel Output: 1, 8 bit

1.3.1 Scanning Range

Table 1-9. Scanning Range

RL (read length)	RW (read width)	OLM (left margin)	OTM (top margin)
297 mm	216 mm	1.5 mm ± 1mm	1.5 mm ± 1mm

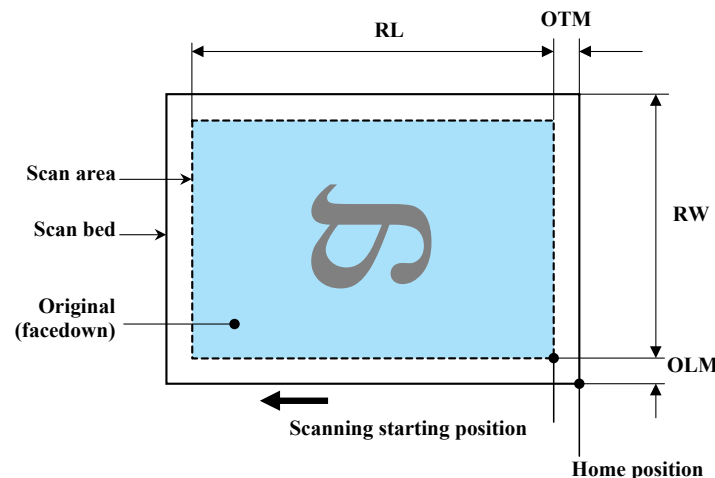


Figure 1-3. Scanning Range

1.4 General Specifications

1.4.1 Electrical Specifications

Table 1-10. Primary Power Specifications

Item		100-120 V model	220-240 V model
Rated power supply voltage		100 to 120 VAC	220 to 240 VAC
Input voltage range		90 to 132 VAC	198 to 264 VAC
Rated current (Max. rated current)		0.6 A (TBD A)	0.4 A (TBD A)
Rated frequency		50 to 60 Hz	
Input frequency range		49.5 to 60.5 Hz	
Insulation resistance		1500 VAC for one minute (between AC lines and chassis)	
Insulation resistance		Higher than 10 M Ω at 500 VDC (between AC lines and chassis)	
Energy conservation		International Energy Star Program compliant	
Power consumption	Standby (Max, when Power off)	1 W	1 W
	Sleep (Max)	3.8 W	3.8 W
	Copying (Normal BK mode, Typ.)	11.7 W	11.5 W
	Copying (Draft BK mode, Max.)	22.1 W	22.4 W

Note 1: If the printer or scanner is not operated for more than three minutes, the printer goes into the power save mode within two minutes.

1.4.2 Environmental Conditions

Table 1-11. Environmental Conditions

Condition	Temperature* ¹	Humidity* ^{1,2}	Shock	Vibration
Operating	10 to 35°C (50 to 95°F)	20 to 80%	1G (1 msec or less)	0.15G, 5 to 55Hz
Storage (in carton box)	-20 to 60°C* ³ (-4°F to 140°F)	5 to 85%	2G (2 msec or less)	1.5G, 5 to 55Hz

Note *1: The combined Temperature and Humidity conditions must be within the blue-shaded range in Fig.1-4.

*2: No condensation

*3: 1 month at 40°C
120 hours at 60°C

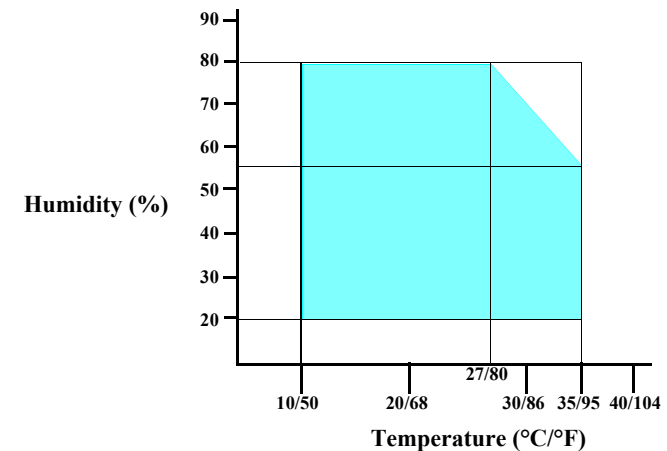


Figure 1-4. Temperature/Humidity Range



- When returning the repaired printer to the customer, make sure the Printhead is covered with the cap and the ink cartridge is installed.
- If the Printhead is not covered with the cap when the printer is off, turn on the printer with the ink cartridge installed, make sure the Printhead is covered with the cap, and then turn the printer off.

1.4.3 Durability

- Total print life: 10,000 pages (A4, 3.5% duty),
or three years which ever comes first
- Printhead: Five billions shots (per nozzle) or five years which ever comes
first
- Scanner carriage: 36,000 cycles of carriage movement

1.4.4 Acoustic Noise

- **T.B.D.** dB
(when printing from PC, on Premium Glossy Photo Paper, in highest quality)
- **T.B.D.** dB (when scanning, default setting)

1.4.5 Safety Approvals (Safety standards/EMI)

USA	UL60950-1 FCC Part15 Subpart B Class B
Canada	CSA/CSA-C22.2 No.60950-1 CAN/CSA-CEI/IEC CISPR 22
Mexico	NOM-019-SCFI-1998
Taiwan	IEC60950-1 :2001 CNS13438 Class B CNS14336
Euro	EN60950-1 EN55022 Class B EN61000-3-2, EN61000-3-3 EN55024 IEC60950-1 :2001 (CE Mark(LCV))
Germany	GS Mark
Russia	GOST-R (IEC60950-1, CISPR 22) GOST-R 51318.22-99 GOST-R 51318.24-99 GOST-R 51317.3.2-99 GOST-R 51317.3.3-99 GOST 26329-84
Singapore	IEC60950-1
Korea	K60950-1 KN22 Class B KN61000-4-2/-3/-4/-5/-6/-11 MIC MARK
China	GB4943 :2001 GB9254, GB17625.1
Hong Kong	IEC60950-1
Argentina	IEC60950-1
Australia	AS/NZS CISPR22 :2002

1.5 Interface

This printer has USB interface of the following specifications.

1.5.1 USB Interface

The table below describes the specifications of the USB interface to connect a PC.

Table 1-12. USB Interface Specifications

Item	USB Device port
Compatible standards	<ul style="list-style-type: none"> • Based on Universal Serial Bus Specifications Revision 2.0 • Universal Serial Bus Device Class Definition for Printing Devices Version 1.1
Transfer rate	12 Mbps (Full Speed)
Data format	NRZI
Compatible connector	USB Series A
Max. cable length	2 [m] or less

Table 1-13. Device ID

When IEEE 1284.4 is Enabled	When IEEE 1284.4 is Disabled
@EJL[SP]ID[CR][LF] MFG:EPSON; CMD:ESCPL2,BDC,D4,D4PX; MDL: <i>Model Name</i> ; CLS:PRINTER; DES:EPSON[SP] <i>Model Name</i> ; [FF]	@EJL[SP]ID[CR][LF] MFG:EPSON; CMD:ESCPL2,BDC; MDL: <i>Model Name</i> ; CLS:PRINTER; DES:EPSON[SP] <i>Model Name</i> ; [FF]

The “*Model Name*” is replaced as shown in the following table.

Table 1-14. Model Names Indicated in the Device ID

Model Name	Country (Product specification)
Stylus NX100	EAI (STD/Mass/Canada)
Stylus SX100	Euro, Euro Premium
Stylus TX100	EAI (Latin 120V Mexico) EAL, ESP, ESP(Phil), EHK, ETT, EKL (WS/Others/LFR)
Stylus TX101	ESP (Inter), ESP (India)
Stylus TX105	EAI (Latin 120V Brazil / Latin 120V Colombia / Latin 220V)
Stylus TX106	CISMEA, CISMEA Premium
ME 300	ECC / ECC (Office)

1.6 Control Panel

1.6.1 Operation Buttons & LEDs

The following buttons and LEDs are equipped on the control panel.

Table 1-15. Buttons & LEDs

	Button/LED	Function
Button	Power	Turns the power ON/OFF.
	Stop	Stops printing immediately and ejects the paper. Cancels the job which is printing/copying at the same time.
	Start Photo	Adjusts the image size to the paper and starts color photo copying.
	Start B&W	Starts B&W copying.
	Start Color	Starts color copying.
LED	Power LED	<ul style="list-style-type: none"> Flashes at power ON/OFF. Flashes during each sequence is in progress. Flashes when a fatal error occurs or maintenance is required. Lights in Ready status.
	Paper LED	Lights or flashes when a paper-related error occurs.
	Ink LED	Lights or flashes when an ink-related error occurs.

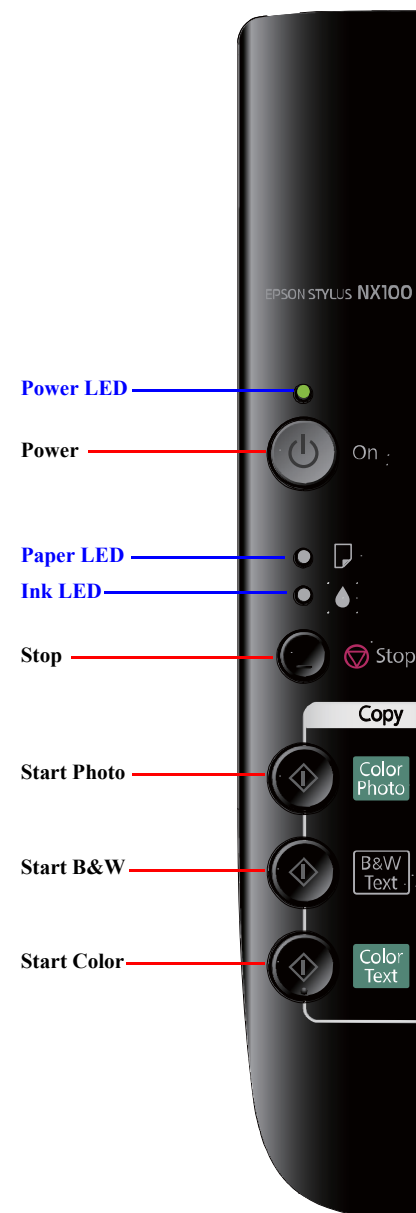


Figure 1-5. Control Panel (EAI version as a sample)

1.6.2 Control Panel Functions

Table 1-16. Buttons Functions

Button	Printer Status	Functions
Power	Power Off	Turns the power OFF.
	Power On	<input type="checkbox"/> Turns the power ON. <input type="checkbox"/> Ejects the paper if the paper is not ejected yet.
Stop	Printing / Copying	Stops printing immediately and ejects the paper. Cancels the job which is printing/copying at the same time.
	Ink Out No Cartridge Incorrect Cartridge	<input type="checkbox"/> Runs a sequence of ink cartridge replacement. <input type="checkbox"/> Performs the following sequence in due order each time the stop button is pressed. <ol style="list-style-type: none"> Moves the carriage to the ink check positions. Moves the carriage there in the order of cyan, magenta, yellow, and black (prioritized order). Moves the carriage to the ink cartridge replacement position after displaying all the colors to be displayed. (Skips the colors with sufficient ink) Moves the carriage back to the home position if it is at the ink cartridge replacement position, and performs replacement cleaning.
	Paper Out / Paper Jam	<input type="checkbox"/> Stops printing and cancels the job. <input type="checkbox"/> Ejects the paper if the paper is not ejected yet. <input type="checkbox"/> Recovers from the error if the ejecting the paper is performed and successful.
	Sleep	<input type="checkbox"/> Recovers from sleep. <input type="checkbox"/> Performs recovering from sleep (Initialization of the printer mechanism, etc.) if necessary.
	At power-on*1	<input type="checkbox"/> Prints the nozzle check pattern.*2 <input type="checkbox"/> After printing the nozzle check pattern, the printer turns on stand-by; the same status after initialization. <input type="checkbox"/> Stops printing and cancels the print job if the stop button is pressed during printing the nozzle check pattern. It becomes ready after ejecting the paper.
Stop (when pressed for 3 seconds or more)	Ready / Ink Low	<input type="checkbox"/> Starts head cleaning. <input type="checkbox"/> Changes to the ink-out error status if the remaining ink level is not enough for cleaning.
	Sleep	<input type="checkbox"/> Recovers from sleep and starts head cleaning. <input type="checkbox"/> Changes to the ink-out error status if the remaining ink level is not enough for cleaning.
Start Photo*3	Ready / Ink Low	Adjust the size to the paper and starts color photo copying.
	Sleep	Recovers from sleep, adjust the size to the paper and starts color photo copying.
Start B&W*3	Ready / Ink Low	Starts B&W copying.
	Sleep	Recovers from sleep and starts B&W copying.
Start B&W*3 (when pressed for 3 seconds or more)	Ready / Ink Low	Adjust the size to the paper and starts B&W copying.
	Sleep	Recovers from sleep, adjust the size to the paper and starts B&W copying.
Start Color*3	Ready / Ink Low	Starts color copying.
	Sleep	Recovers from sleep and starts color copying.

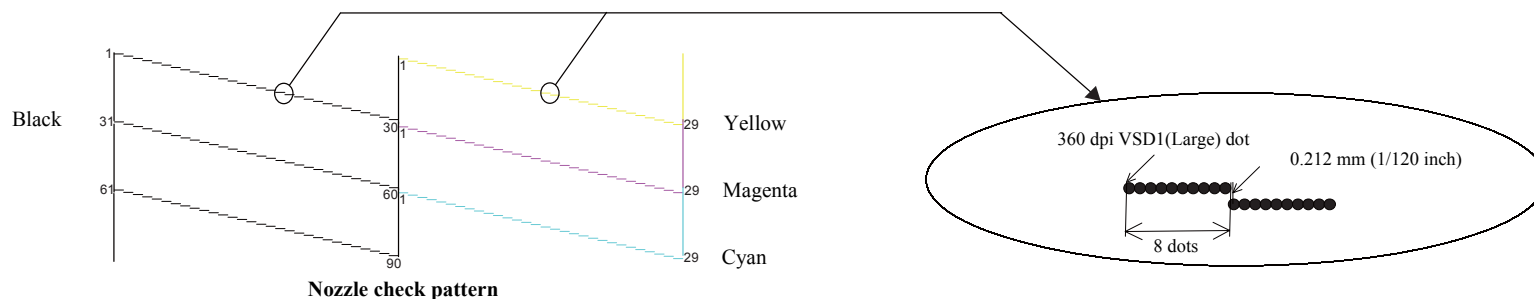
Table 1-16. Buttons Functions

Button	Printer Status	Functions
Start Color* ³ (when pressed for 3 seconds or more)	Ready / Ink Low	Adjust the size to the paper and starts color copying.
	Sleep	Recovers from sleep, adjust the size to the paper and starts color copying.
Stop + Start B&W	Ready / Ink Low	Starts B&W copying in the draft mode.
	Sleep	Recovers from sleep and starts B&W copying in the draft mode.
Stop + Start Color	Ready / Ink Low	Starts color copying in the draft mode.
	Sleep	Recovers from sleep and starts color copying in the draft mode.
Start Photo + Start B&W	Ready / Ink Low	Makes 20 copies in B&W copying.
	Sleep	Recovers from sleep and makes 20 copies in B&W copying.
Start Photo + Start Color	Ready / Ink Low	Makes 20 copies in color copying.
	Sleep	Recovers from sleep and makes 20 copies in color copying.

Note *1: If the stop button is pressed when the power LED begins to flash, the nozzle check function becomes available.

(This function becomes available if the stop button is pressed at the above timing regardless of whether the power button is being pressed or not.)

*2: The nozzle check pattern is as follows. Numbers in the figure indicate nozzle numbers. In actual check patterns, the version of firmware is also printed.
(Nozzle numbers and color names are not printed.)



*3: When displaying a paper out error : If the paper feeding finishes successfully, cancels the error and continues the procedure.
When displaying a paper jam error : If the paper ejection finishes successfully, cancels the error and continues the procedure.

Table 1-17. LED Functions

Printer Status	LED			Priority
	Power LED	Paper LED	Ink LED	
Power OFF (processing)	High-speed flashing	OFF	OFF	1
Fatal error (system error)	High-speed flashing	High-speed flashing	High-speed flashing	2
Fatal error (mechanical error)	Flashing	Flashing	Flashing	3
Maintenance request (Waste ink overflow)	Flashing	ON	ON	4
Power ON (initializing)	Flashing	---	---	5
Paper jam error	---	Flashing	OFF	6
Multi-feed error	---	Flashing	OFF	7
Ink out error / No ink cartridge error Ink cartridge detection error	---	OFF	ON	8
Ink cartridge replacement is in progress	Flashing 2	OFF	Flashing 2	9
Ink sequence is in progress	Flashing	---	---	10
No paper error	---	ON	OFF	11
Copying	Flashing	---	---	12
Printing from PC	Flashing	---	---	13
Scanner operation from PC	Flashing	---	---	14
Power ON (Print data processing)	Flashing	---	---	15
Ink low	---	---	Flashing	16
Power ON (normal idle state)	ON	---	---	17
Power ON (Sleep)	Low-speed flashing	OFF	OFF	-
Printing & job being canceled	Flashing	---	---	-

Note : --- : No change
 Flashing : Repeats ON and OFF every 1.25 seconds.
 Flashing 2 : Repeats ON for 0.5 second, OFF for 0.5 second, ON for 0.5 second, and OFF for 1.0 second.
 High-speed flashing : Repeats ON and OFF every 0.5 second.
 Low-speed flashing : Repeats ON and OFF every 2 seconds.

Note : See “3.2 Error Indications and Fault Occurrence Causes” (p.29) for remedies for errors.

1.7 Stand-alone Copy Function

1.7.1 Supported Paper and Copy Mode

Table 1-18. Supported Paper and Copy Mode

Paper Type	Size	Print Quality	Resolution	Dot Size	Bi-D	Micro Weave	Borderless
Plain paper	A4, Letter	Draft	360x120	Eco	ON	OFF	NA
		Standard	360x360	VSD1	ON	OFF	NA
Photo Paper	4" x 6"	Standard	1440x720	VSD3	ON	ON	OK

1.7.2 Setting for Stand-alone Copy

You can make settings by a specific key operation to select color copy, B&W copy, or photo copy. Refer to Table 1-16 for key operation methods.

Table 1-19. Settings for Stand-alone Copy

Settings		Function
Copy type		Select from color copy, B&W copy or photo copy by a key operation.
Layout		<ul style="list-style-type: none"> Color Copy, B&W Copy Normal layout with 3mm margins Photo Copy Borderless (The area size of projections: Fixed to Maximum.)
Print setting	Paper type	Refer to Table 1-18.
	Paper size	
	Quality	
Fit to Page		<p>When "Fit to Page" is selected by the key operation, a copy is made adjusting the image size to the paper by enlarging/reducing the original. The zoom ratio is determined as follows, and the same ratio is applied to both horizontal and vertical sides.</p> <ul style="list-style-type: none"> Detects the image size of the original using the preview function. Calculates an appropriate zoom ratio from the image size and the printable area of the paper. If the ratio falls into less than 25%, 25% is applied. 400% is applied if over 400% likewise. For color/B&W copying, the zoom ratio is determined so as to make a copy of the whole image of the original on the paper. For photo copying, the zoom ratio is determined so as not to leave any margins on the paper.

1.7.2.1 Relation Between Original and Copy

The scanning start position is located on the front right of the scan bed. The relations between the original placed face down and its copy are as follows.

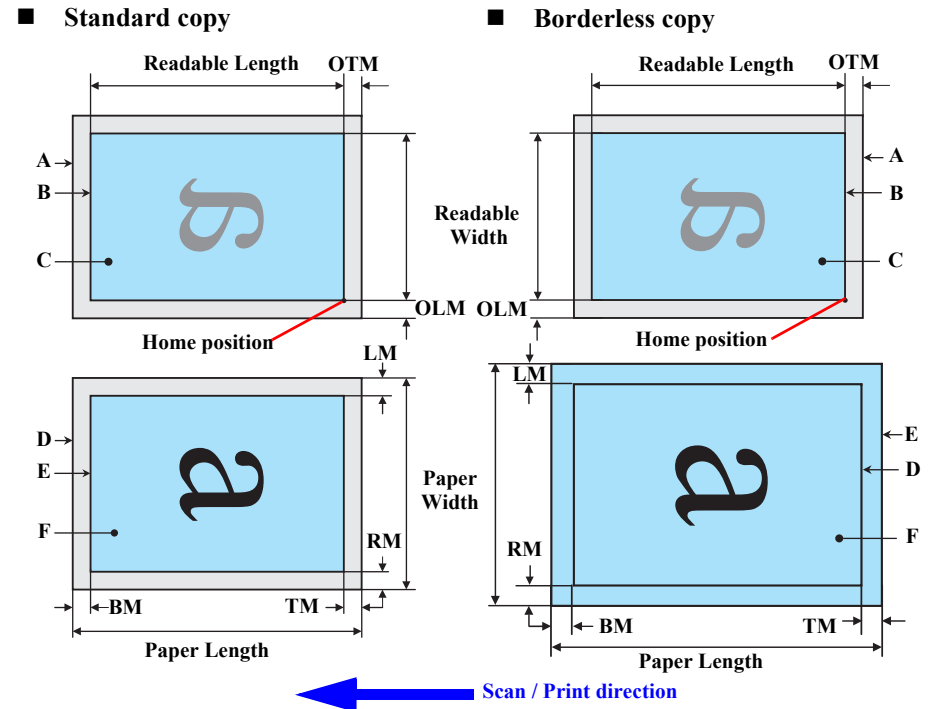


Figure 1-6. Relation Between Original and Copy (Borderless/With Borders)

Original Document

A	Scan bed	---
B	Scan area	"1-9 Scanning Range" (p.14)
C	Original (face down)	---
OTM	Top margin (out of scan range)	"1-9 Scanning Range" (p.14)
OLM	Left margin (out of scan range)	"1-9 Scanning Range" (p.14)

Copied Document

D	Copied paper	---
E	Print area	"1-7 Printing Area (Margins)" (p.14)
F	Copy	---
LM, RM	Left margin, Right margin	"1-7 Printing Area (Margins)" (p.14)
TM, BM	Top margin, Bottom margin*	

1.7.3 Copy Speed

Table 1-20. Copy Speed

Copy Conditions (eMemo, A4 size, per copy)		Time	
Plain paper	360 x 120 dpi	Monochrome copy	5 sec
		Color copy	14 sec
	360 x 360 dpi	Monochrome copy	20 sec
		Color copy	72 sec

1.7.4 Multiple Copying

Making 20 (fixed value) copies in color/B&W becomes available by operating specific keys (Refer to [p. 18](#)). In this copying, the second copy or later are carried out without scanning by storing the scanned data in the memory to makes copying faster. However, if the scanned data is bigger than the memory's capacity, scanning will be repeated for each copy. The conditions that the scanned data can be stored in the memory are as follows.

Table 1-21. Conditions for Storing the Scanned Data

Copy Mode	Print Quality	Storing the data/repeating scanning
Color copy Monochrome copy	Draft	The scanned data can be stored. The second or later will be printed without scanning.
	Standard	Tries to compress the scanned data to store it in the memory. Some data can not be stored, scanning will be repeated after the second in that case.

CHAPTER

2

OPERATING PRINCIPLES

2.1 Overview

This chapter describes the mechanism of Epson STYLUS NX100/NX105/SX100/SX105/TX100/TX101/TX102/TX103/TX105/TX106/TX109/ME 300.

2.1.1 Printer Mechanism

Epson STYLUS NX100/NX105/SX100/SX105/TX100/TX101/TX102/TX103/TX105/TX106/TX109/ME 300 printer mechanism consists of printhead, carriage mechanism, paper loading mechanism, paper feed mechanism, and ink system.

As the conventional models, Epson STYLUS NX100/NX105/SX100/SX105/TX100/TX101/TX102/TX103/TX105/TX106/TX109/ME 300 is equipped with two DC motors; one is used to drive the paper loading, paper feed mechanisms, and the pump mechanism that includes the carriage lock mechanism, and another one is used to drive the carriage mechanism. A paper is fed from the rear ASF unit by means of the LD roller and Retard roller and ejected to the front tray.

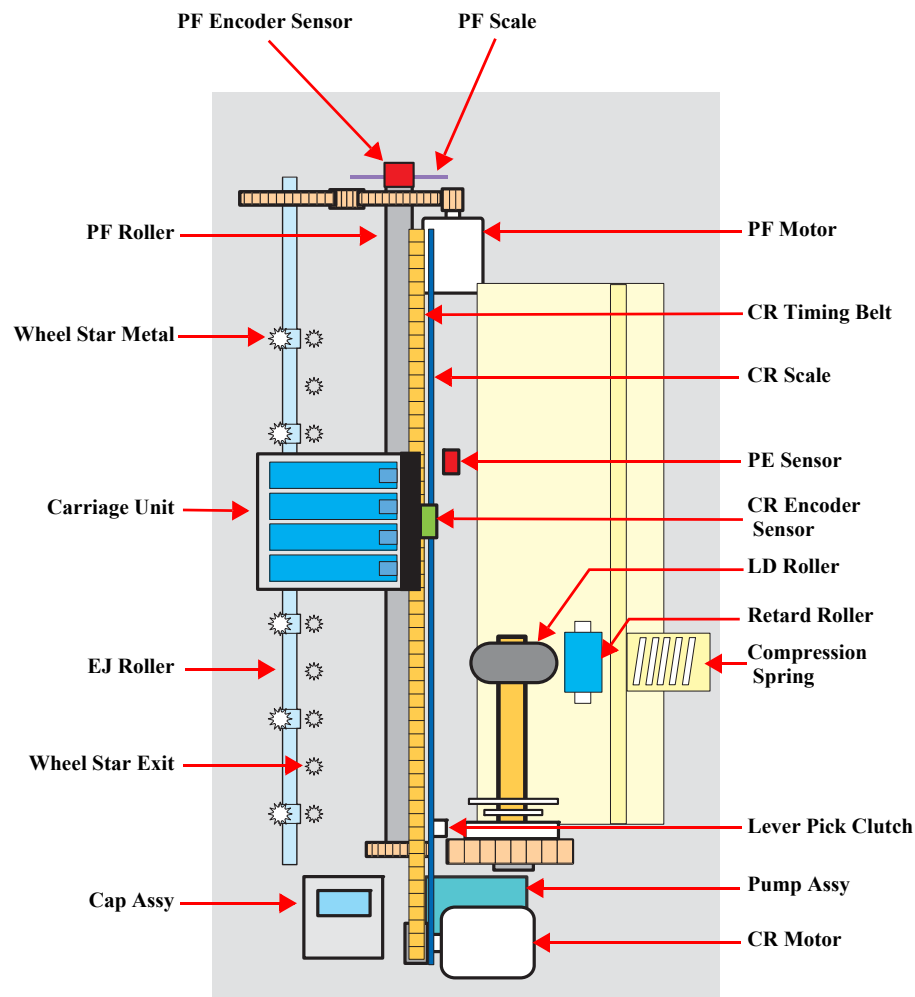


Figure 2-1. Printer Mechanism block diagram

2.1.2 Motors & Sensors

Epson STYLUS NX100/NX105/SX100/SX105/TX100/TX101/TX102/TX103/TX105/TX106/TX109/ME 300 printer mechanism is equipped with the following printhead, motors and sensors.

Table 2-1. Printer Mechanism Motors & Sensors

No.	Name	Specification
1	Printhead	Refer to "2.1.3 Printhead" (p.26)
2	CR Motor	Type: DC motor Drive voltage: 42VDC +/- 5% (DRV IC voltage) Coil resistance: TBD Inductance: TBD Drive method: PWM, constant-current chopping
3	PF Motor	Type: DC motor Drive voltage: 42VDC +/- 5% (DRV IC voltage) Coil resistance: TBD Inductance: TBD Drive method: PWM, constant-current chopping
4	PE Sensor	Purpose : Detection of paper top and bottom edge, for control to set paper at the print start position Type: Photo interrupter
5	CR Contact Module	CSIC board
6	CR Encoder Sensor	Type: Photo interrupter Resolution: TBD
7	PF Encoder Sensor	Type: Photo interrupter Resolution: TBD

Table 2-2. Scanner Mechanism CIS & Motor

No.	Name	Specification
1	CIS Unit	Resolution :600 dpi (Main) x 1200 dpi (Sub) Pixel Depth :16 bit per pixel (input) 1, 8 bit per pixel (output)
2	CR Motor	Type :TBD Voltage :TBD Coil resistance :TBD Inductance :TBD Drive method :PWM

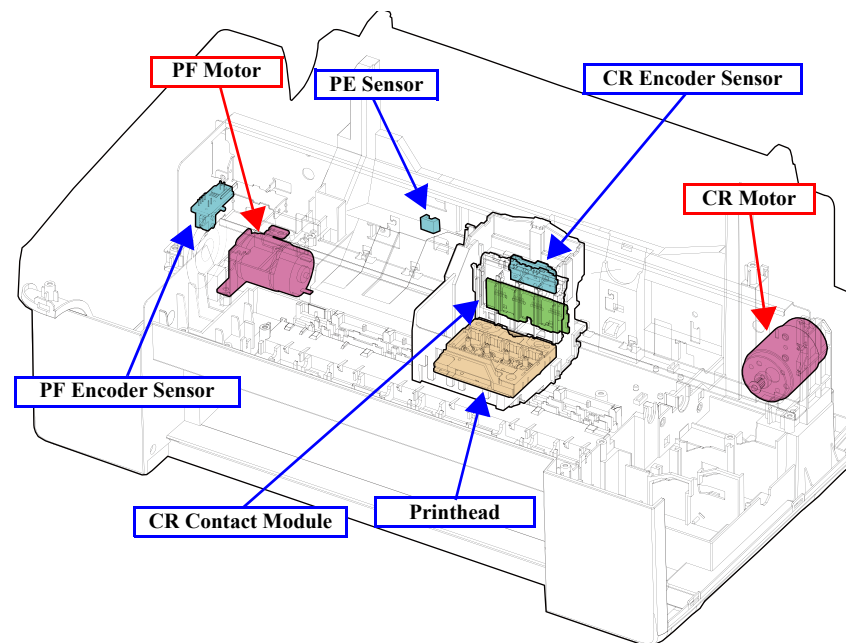


Figure 2-2. Motors & Sensors in Printer Mechanism

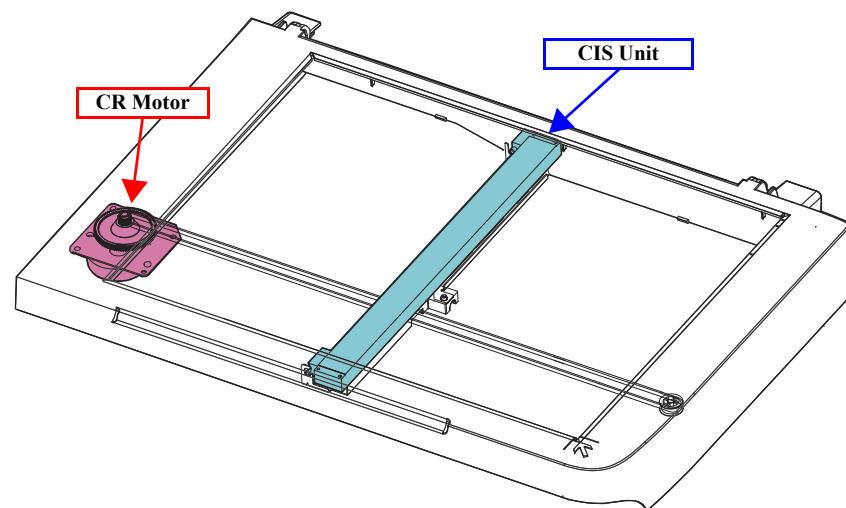


Figure 2-3. CIS Unit and CR Motor in Scanner Mechanism

2.1.3 Printhead

The D2 Chips type printhead is employed.

□ Nozzle configuration

- Black: 90 nozzles x 1
- Color: 29 nozzles x 3 (cyan, magenta, yellow)

The nozzle layout as seen from behind the printhead is shown below.

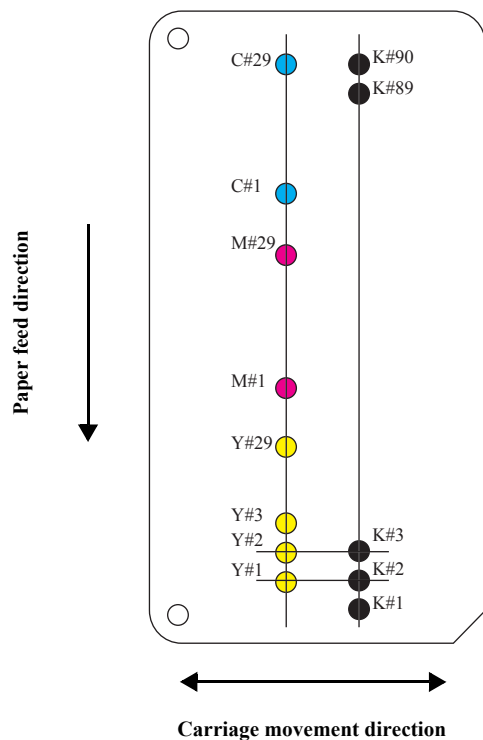


Figure 2-4. Nozzle Layout

CHAPTER

3

TROUBLESHOOTING

3.1 Overview

This chapter describes how to solve problems.



- Be careful to avoid electric shocks when checking the electrical circuit boards (MAIN and PSE/PSB boards) while the power is turned on.
- Touching an FET, transistor or heat sink with one hand while touching a metal part of the mechanism with the other hand could result in an electric shock, so carefully avoid this.
- After initial filling of ink has been repeated several times, immediate moving or tilting of the printer could result in leaking of ink that has not been completely absorbed by the Waste Ink Pad. When initial filling of ink has been repeated several times, check the ink remaining in the tip of the Waste Ink Tube and the waste ink not absorbed by the Waste Ink Pad before moving the printer.



- Disassembly and reassembly of parts is often required when identifying the causes of problems. The parts should be disassembled and re-assembled correctly while referring to “DISASSEMBLY/ASSEMBLY” (p.54) so that the operation and status of each check item can be correctly verified.
- Some individual part and units may require adjustment once they are removed or replaced. If removing or replacing parts which have specific instructions for adjustment included in “DISASSEMBLY/ASSEMBLY” (p.54), be sure to make these adjustments after repairing the problem location.

3.1.1 Specified Tools

This printer does not require any specified tools for troubleshooting.

3.1.2 Preliminary Checks

Before starting troubleshooting, be sure to verify that the following conditions are all met:

- The power supply voltage must be within the specification limits. (Measure the voltage at the wall socket.)
- The power code must be free from damage, short circuit or breakage, or miswiring in the power code.
- The printer must be grounded properly.
- The printer should not be located in a place where it can be exposed to too high or low temperature, too high or low humidity, or abrupt temperature change.
- The printer should not be located near waterworks, near humidifiers, near heaters or near flames, in a dusty atmosphere or in a place where the printer can be exposed to blast from an air conditioner.
- The printer should not be located in a place where volatile or inflammable gases are produced.
- The printer should not be located in a place where it can be exposed to direct rays of the sun.
- The printer must be placed on a strong and steady level table (without an inclination larger than five degrees).
- Any vibrating equipment must not be placed on or under the printer.
- The paper used must conform to the specification.
- There is no error in handling of the printer.
- Check the inside of the printer, and remove foreign matters if any, such as paper clips, staples, bits of paper, paper dust or toner.
- Clean the inside of the printer and the rubber rolls.

3.2 Error Indications and Fault Occurrence Causes

This chapter describes how the printer indicates an error status with LEDs, and why the error is caused, when a problem happened during each sequence/operation (power-on sequence, paper feeding, ink drawing, and so on).

Table 3-1. Error Indications and Fault Occurrence Causes

Error Name	LED Indications			Error Cause	Reference
	Power	Paper	Ink		
Fatal error (scanner)	High-speed flashing	High-speed flashing	High-speed flashing	<ul style="list-style-type: none"> RAM trouble occurs. System trouble occurs. 	Table 3-2. (p30)
Fatal error (printer mechanism)	Flashing	Flashing	Flashing	Mechanical trouble occurs.(CR error, PF error etc.)	
Maintenance error (waste ink overflow)	Flashing	ON	ON	The waste ink counter exceeds to capacity.	Table 3-3. (p36)
Paper jam error	--	Flashing	OFF	Paper stays in the paper path after paper ejection.	Table 3-4. (p37)
Paper out error	--	ON	OFF	Failure to load paper to print.	Table 3-5. (p40)
Double feed error	--	Flashing	OFF	Double feed during double sided printing.	Table 3-6. (p42)
Ink out error / No ink cartridge error/ Ink cartridge detection error	--	OFF	ON	<ul style="list-style-type: none"> The cartridge has run out of ink. The printer could not detect the cartridge. The printer detected non-Epson cartridge. Writing to/reading from the CSIC could not be made. 	Table 3-7. (p43)

Note : --: No change
 Flashing: Repeats ON and OFF every 1.25 seconds.
 High-speed flashing: Repeats ON and OFF every 0.5 second.

3.2.1 Troubleshooting by Error Message

The following tables provide troubleshooting procedures. Confirm the error message indicated on the LED or the STM3 screen on the PC's display, and verify it in the following list and the figures at the end of this chapter for the corresponding troubleshooting remedy. If some parts need to be replaced or repaired, make sure to follow the procedure given in Chapter 4 "Disassembly / Assembly".

Table 3-2. Check point for Fatal error according to each phenomenon

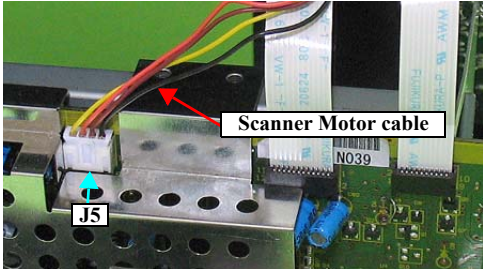
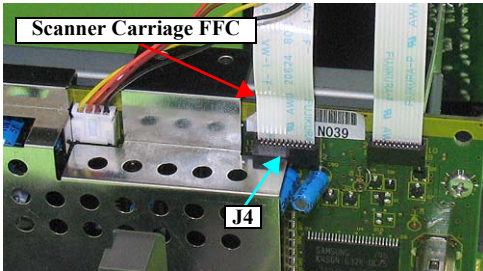
Occurrence timing CR position	Detailed phenomenon	Defective unit/part name	Check point	Remedy
<ul style="list-style-type: none"> • Power on • Anywhere 	The Scanner Unit does not initialize when the power is turned on.	Scanner Motor	1. Check if the Scanner Motor cable is connected to J5 on the Main Board.	1. Connect the Scanner Motor cable to J5 on the Main Board.
				2. Replace the Scanner Motor with a new one.
			2. Check if the coil resistance of the Scanner Motor is TBD Ω or by using the tester (refer to Table 3-13).	3. Replace the Scanner Motor Unit with a new one.
		3. Check if the Scanner Motor Cable is damaged.	1. Replace the Scanner Motor Unit with a new one.	
		Scanner Carriage FFC	1. Check if the Scanner Carriage FFC is connected to J4 on the Main Board.	1. Connect the Scanner Carriage FFC to J4 on the Main Board.
				2. Replace the Scanner unit with a new one.
CIS Unit	1. Check if the CIS Unit is damaged.	1. Replace the CIS Unit with a new one.		

Table 3-2. Check point for Fatal error according to each phenomenon

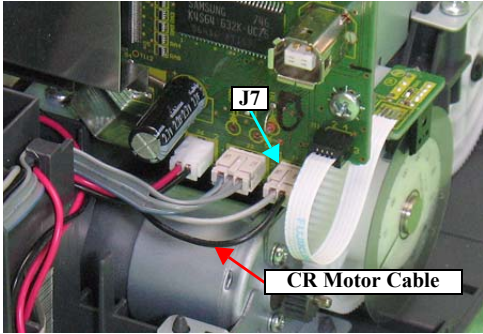
Occurrence timing CR position	Detailed phenomenon	Defective unit/part name	Check point	Remedy	
<ul style="list-style-type: none"> • Operation • Anywhere 	The Scanner Carriage Unit. does not operate.	Lower Scanner Housing	1. Check if the grease is enough on the Guide Rail of the Lower Scanner Housing. (TBD)	1. After wiping the grease on the Guide Rail of the Lower Scanner Housing with a dry, soft cloth, coat it with grease. (Refer to Chapter 6 "MAINTENANCE" (p.116).) (TBD)	
			2. Check if the Scanner Carriage Unit is correctly assembled.	2. Reassemble the Scanner Carriage Unit correctly.	
<ul style="list-style-type: none"> • Power on • Anywhere 	When turning on the power, the CR Motor does not operate at all.	CR Motor	1. Check if the CR Motor Cable is connected to J7 on the Main Board.	1. Connect the CR Motor Cable to J7 on the Main Board.	
					
			2. Check if the CR Motor Cable is damaged.	2. Replace the CR Motor with a new one.	
3. Check if the CR Motor operates.	3. Replace the CR Motor with a new one.				

Table 3-2. Check point for Fatal error according to each phenomenon

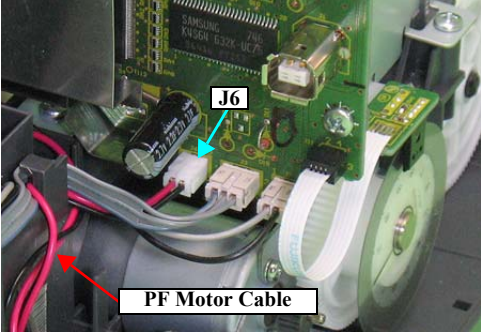
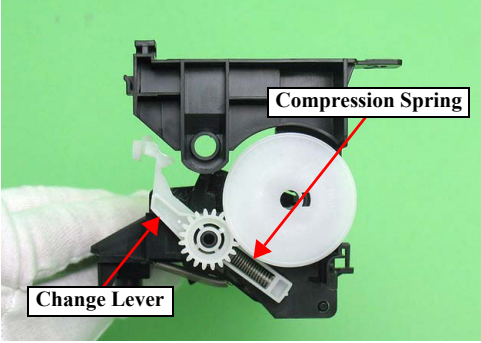
Occurrence timing CR position	Detailed phenomenon	Defective unit/part name	Check point	Remedy
<ul style="list-style-type: none"> • Power on • Anywhere 	When turning on the power, the PF Motor does not operate at all	PF Motor	1. Check if the PF Motor Cable is connected to J6 on the Main Board. 	1. Connect the PF Motor Cable to J6 on the Main Board.
	When turning on the power, the Carriage Unit collides to the Change Lever located to the front side of the printer.	PF Motor	1. Check if the PF Motor Connector Cable is connected to J6 on the Main Board. 2. Check if the PF Motor Connector Cable is damaged. 3. Check if the PF Motor operates.	1. Connect the PF Motor Cable to J6 on the Main Board. 2. Replace the PF Motor with a new one. 3. Replace the PF Motor with a new one.
		ASF Unit	1. Check if the Compression Spring comes off from the Change Lever. 	1. Replace the Change Lever and the Compression Spring with new ones.

Table 3-2. Check point for Fatal error according to each phenomenon

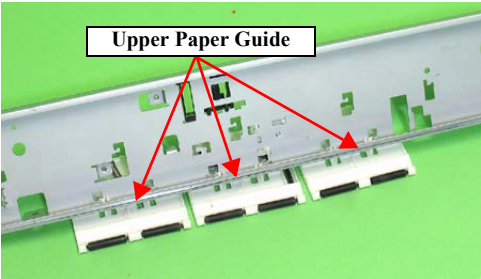
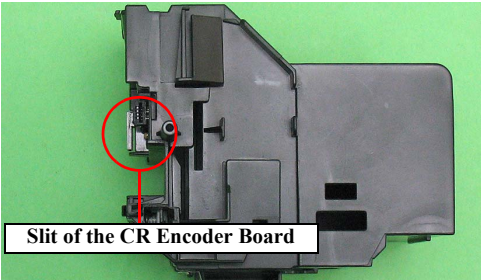
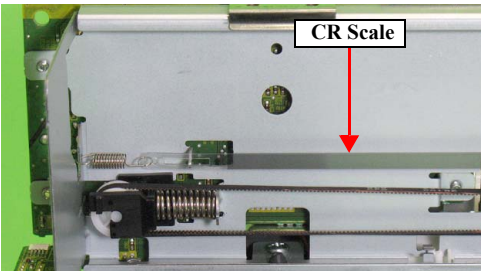
Occurrence timing CR position	Detailed phenomenon	Defective unit/part name	Check point	Remedy
	The Carriage Unit collides with the Upper Paper Guide Unit when power is turned on.	Upper Paper Guide	1. Check if the Upper Paper Guide is correctly assembled. 	1. Reassemble the Upper Paper Guide to the Main Frame correctly.
<ul style="list-style-type: none"> • Power on • Anywhere 	When turning on the power, the Carriage Unit collides to the right side of the Main Frame.	CR Scale	1. Check if the CR Scale does not come off or it properly passes through the slit of the CR Encoder Board.  2. Check if the CR Scale is damaged or contaminated. 	1. Reassemble the CR Scale correctly. * If the problem is not solved, replace the Main Board with a new one. 2. Replace the CR Scale with a new one or clean it completely.

Table 3-2. Check point for Fatal error according to each phenomenon

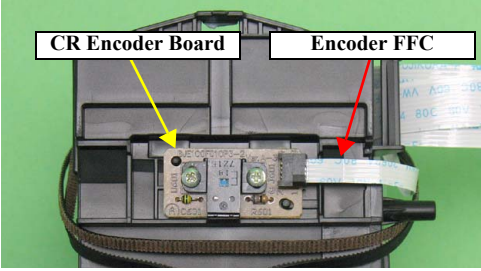
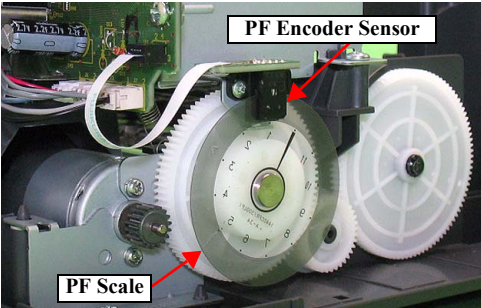
Occurrence timing CR position	Detailed phenomenon	Defective unit/part name	Check point	Remedy
<ul style="list-style-type: none"> • Power on • Anywhere 	When turning on the power, the Carriage Unit collides to the right side of the Main Frame.	CR Encoder Board	<ol style="list-style-type: none"> 1. Check if the Encoder FFC is connected to the CR Encoder Board.  <ol style="list-style-type: none"> 2. Check if the Encoder FFC is damaged. 3. Check if the CR Encoder Board is damaged. 	<ol style="list-style-type: none"> 1. Connect the Encoder FFC to the CR Encoder Board. 2. Replace the Encoder FFC with a new one. 3. Replace the CR Encoder Board with a new one.
	The eject rollers are rotating at high speed when power is turned on. (For about 1 cycle.)	PF Scale/ PF Encoder Sensor	<ol style="list-style-type: none"> 1. Check if the PF Scale is damaged or contaminated.  <ol style="list-style-type: none"> 2. Check if the PF Encoder Sensor is damaged. 	<ol style="list-style-type: none"> 1. Replace the PF Scale with a new one. 2. Replace the PF Encoder Sensor with a new one.

Table 3-2. Check point for Fatal error according to each phenomenon

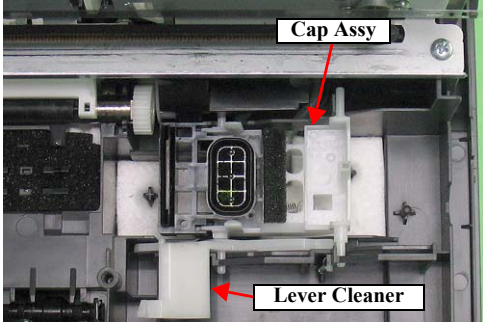
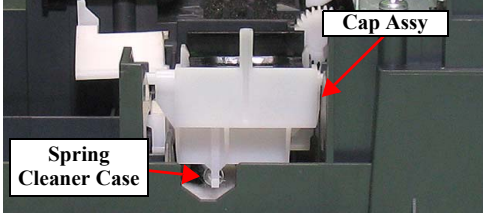
Occurrence timing CR position	Detailed phenomenon	Defective unit/part name	Check point	Remedy
<ul style="list-style-type: none"> • Power on • Anywhere 	When turning on the power, the Carriage cannot get out of home position.	Ink System	1. Check if the Cap Assy and the Lever Cleaner are assembled correctly. 	1. Reassemble the Cap Assy and Lever Cleaner correctly.
			2. Check if the Spring Cleaner Case does not come off in the Cap Assy. 	2. Reassemble the Spring Cleaner Case correctly.

Table 3-2. Check point for Fatal error according to each phenomenon

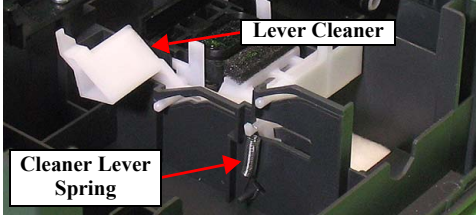
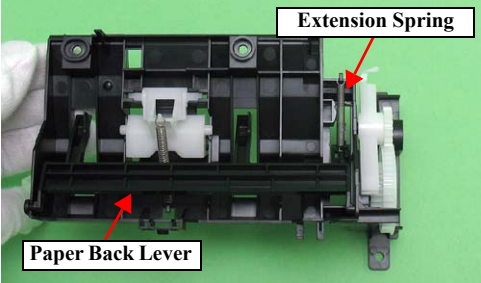
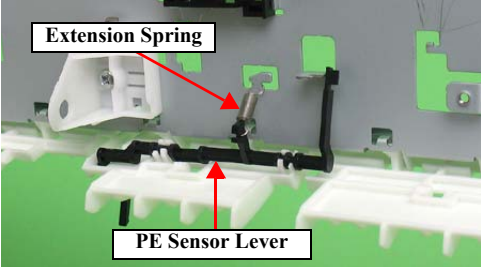
Occurrence timing CR position	Detailed phenomenon	Defective unit/part name	Check point	Remedy
<ul style="list-style-type: none"> • Power on • Anywhere 	When turning on the power, the Carriage cannot get out of home position.	Ink System	3. Check if the Spring Cleaner Lever comes off from the Lever Cleaner.	3. Reassemble the Cleaner Lever Spring correctly.
				
			4. Check the routing of the Waste Ink Tube.	
		5. Check if the Cap Assy is damaged.	5. Replace the Cap Assy with a new one.	
		Main Frame	1. Check if the Main Frame is deformed.	1. Replace the Main Frame with a new one.

Table 3-3. Check point for the Maintenance request according to each phenomenon

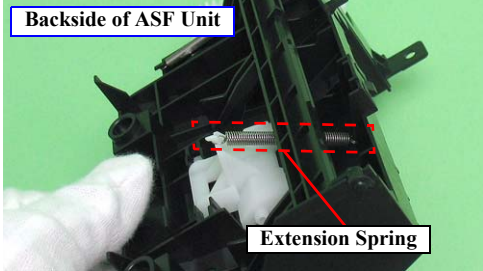
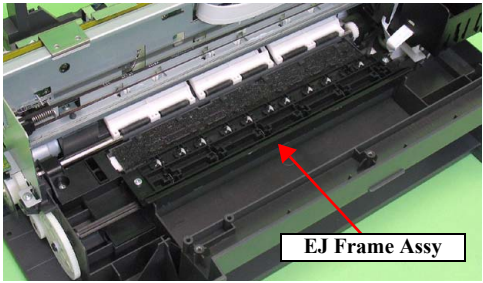
Occurrence timing CR position	Detailed phenomenon	Defective unit/part name	Check point	Remedy
<ul style="list-style-type: none"> • Operation • – 	An error is indicated on the LED and STM or LCD.	Waste Ink Pads	---	1. Change the Waste Ink Pads and initialize the Waste Ink Pad Counter. (Refer to Chapter 5 "ADJUSTMENT" (p.100))

Table 3-4. Check point for Paper jam error according to each phenomenon

Occurrence timing CR position	Detailed phenomenon	Defective unit/part name	Check point	Remedy
<ul style="list-style-type: none"> • Operation • Outside HP 	A paper feeding sequence failed to feed the paper, but a paper ejection sequence is performed.	ASF Unit	<ol style="list-style-type: none"> 1. Check if the ASF Unit is properly installed. 2. Check if the Paper Back Lever operates correctly in the paper loading sequence.  <p>The diagram shows the ASF Unit with two red arrows pointing to the Paper Back Lever and the Extension Spring. Labels 'Paper Back Lever' and 'Extension Spring' are placed next to the arrows.</p>	<ol style="list-style-type: none"> 1. Install the ASF Unit properly. 2. Set the Extension Spring between the ASF Housing and the Paper Back Lever.
		Upper Paper Guide*	<ol style="list-style-type: none"> 1. Check if the Extension Spring is properly installed.  <p>The diagram shows the Upper Paper Guide with two red arrows pointing to the Extension Spring and the PE Sensor Lever. Labels 'Extension Spring' and 'PE Sensor Lever' are placed next to the arrows.</p>	<ol style="list-style-type: none"> 1. Set the Extension Spring between the Main Frame and the PE Sensor Lever.

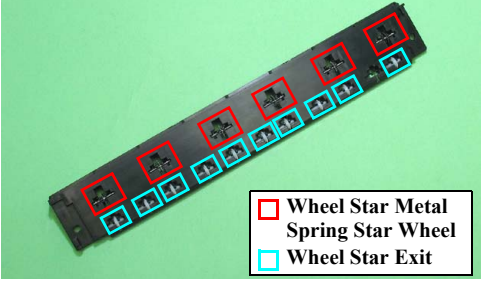
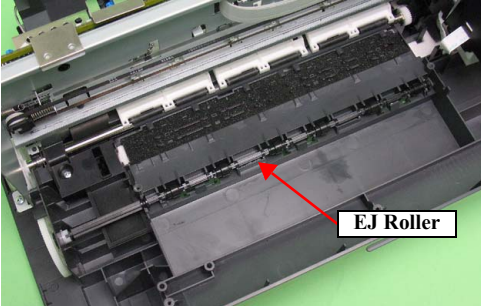
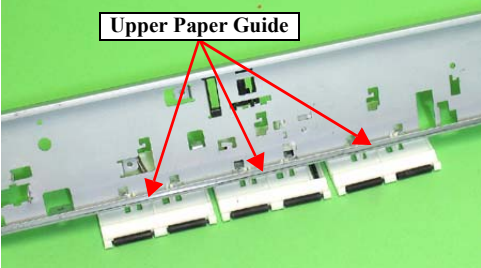
Note * : In case that the paper jam error occurs in each operation, the jammed paper contacts the nozzle surface of the Printhead and the Printhead may be damaged.

Table 3-4. Check point for Paper jam error according to each phenomenon

Occurrence timing CR position	Detailed phenomenon	Defective unit/part name	Check point	Remedy
<ul style="list-style-type: none"> • Operation • Outside HP 	Paper is being resent during paper feeding operation.	ASF Unit	1. Check if the Extension Spring operates correctly in the paper loading sequence. 	1. Set the Extension Spring between the Retard Roller Assy and the ASF Housing.
	When turning on the power, the Carriage Unit move to the home position correctly. But, the paper feeding sequence is performed without loading paper in the paper loading sequence.	Upper Paper Guide	1. Check if the Extension Spring is properly installed.	1. Set the Extension Spring between the Main Frame and the PE Sensor Lever.
<ul style="list-style-type: none"> • Operation • – 	The top edge of paper does not go through between the EJ Roller Unit and the EJ Frame Assy.	EJ Frame Assy*	1. Check if the EJ Frame Assy is correctly assembled. 	1. Reassemble the EJ Frame Assy correctly.

Note *: In case that the paper jam error occurs in each operation, the jammed paper contacts the nozzle surface of the Printhead and the Printhead may be damaged.

Table 3-4. Check point for Paper jam error according to each phenomenon

Occurrence timing CR position	Detailed phenomenon	Defective unit/part name	Check point	Remedy
<ul style="list-style-type: none"> • Operation • — 	<p>The top edge of paper does not go through between the EJ Roller Unit and the EJ Frame Assy.</p>	EJ Frame Assy*	<p>2. Check if the Wheel Star Metal, Spring Star Wheel and Wheel Star Exit come off.</p> 	<p>2. Reassemble the Wheel Star Metal, Spring Star Wheel and Wheel Star Exit correctly.</p>
		EJ Roller*	<p>1. Check if the EJ Roller is correctly assembled.</p>  <p>2. Check if the EJ Roller Gear is damaged.</p>	<p>1. Reassemble the EJ Roller correctly.</p> <p>2. Replace the EJ Roller Gear with a new one.</p>
	<p>The top edge of paper is not loaded to the PF Roller Unit.</p>	Upper Paper Guide*	<p>1. Check if the Upper Paper Guides correctly assembled.</p> 	<p>1. Reassemble the Upper Paper Guide to the Main Frame correctly.</p>

Note * : In case that the paper jam error occurs in each operation, the jammed paper contacts the nozzle surface of the Printhead and the Printhead may be damaged.

Table 3-5. Check point for Paper out error according to each phenomenon

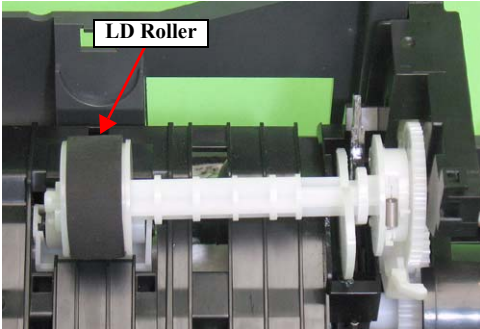
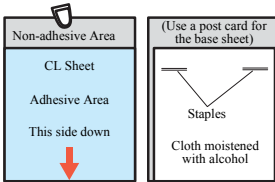
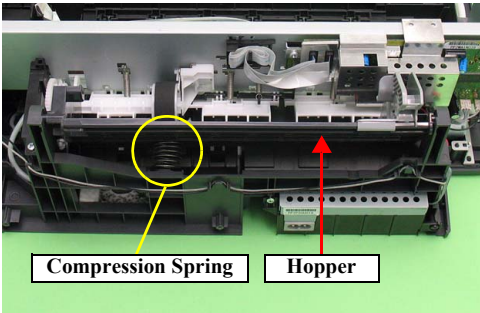
Occurrence timing CR position	Detailed phenomenon	Defective unit/part name	Check point	Remedy
<ul style="list-style-type: none"> • Operation • – 	The LD Roller cannot pick up paper although the LD Roller attempt to rotate correctly.	ASF Unit	1. Check if any paper dust is adhered to the surface of the LD Roller. 	1. Set a cleaning sheet in the ASF Unit up side down. Then holding the top edge, try to load the paper from the Printer driver. The micro pearl on the LD Roller surface is removed. To remove severe smear, staple a cloth moistened with alcohol to a post card and clean the roller in the same manner.  <p>*If the problem is not solved, replace the ASF unit with a new one.</p>
	The Hopper does not operate during the paper loading sequence although the LD Roller rotates to load paper from the ASF Unit.	Hopper	1. Check if the Hopper operates correctly in the paper loading sequence. 	1. Reassemble the Compression Spring between the Lower Housing and the Hopper.

Table 3-5. Check point for Paper out error according to each phenomenon


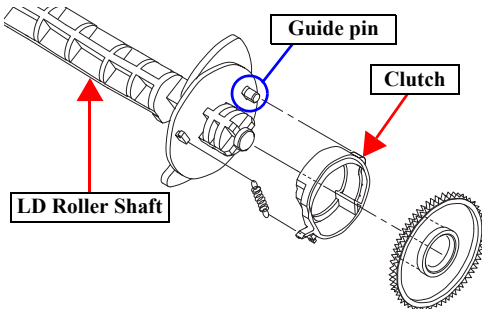
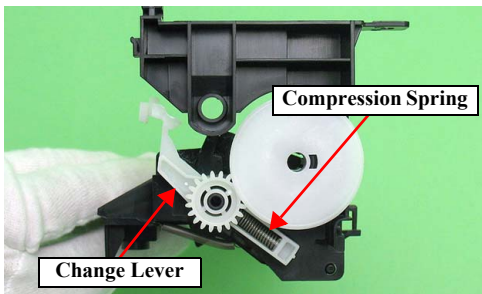
Occurrence timing CR position	Detailed phenomenon	Defective unit/part name	Check point	Remedy
<ul style="list-style-type: none"> • Operation • - 	The drive of the PF Motor is not transmitted to the LD Roller Shaft.	LD Roller Assy	1. Check if the Extension Spring comes off from the Clutch mechanism. 	1. Reassemble the Extension Spring in the Clutch mechanism.
			2. Check if the positioning hole of the Clutch comes off from the guide pin of the LD Roller Shaft. 	2. Reassemble the positioning hole of the Clutch on the guide pin of the LD Roller Shaft.
			3. Check if the Clutch tooth is damaged.	3. Replace the LD Roller Assy with a new one.
			4. Check if the Clutch is damaged.	4. Replace the LD Roller Assy with a new one.
		ASF Unit	1. Check if the Compression Spring comes off from the Change Lever. 	1. Replace the Change Lever and Compression Spring with new ones.

Table 3-5. Check point for Paper out error according to each phenomenon

Occurrence timing CR position	Detailed phenomenon	Defective unit/part name	Check point	Remedy
<ul style="list-style-type: none"> • Operation • – 	The LD Roller is not set to the ASF home position and paper is always loaded from the ASF Unit during the paper loading sequence.	ASF Unit	1. Check if the tip of the Change Lever is damaged.	1. Replace the Change Lever with a new one.

Table 3-6. Check point for Double feed error according to each phenomenon

Occurrence timing CR position	Detailed phenomenon	Defective unit/part name	Check point	Remedy
<ul style="list-style-type: none"> • Operation • – 	After both surfaces were printed, the paper was ejected but an error is displayed.	ASF Unit	1. Check if the Extension Spring operates correctly in the paper loading sequence.	1. Set the Extension Spring between the Retard Roller Assy and the ASF Housing.
			2. Check if the Paper Back Lever operates correctly in the paper loading sequence.	2. Set the Extension Spring between the ASF Housing and the Paper Back Lever.

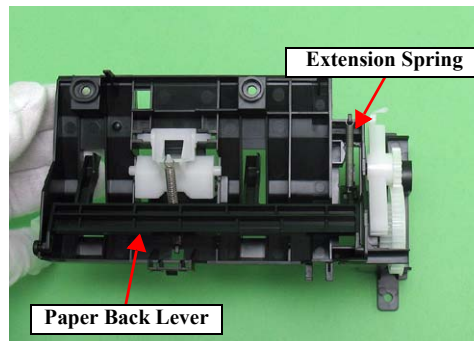
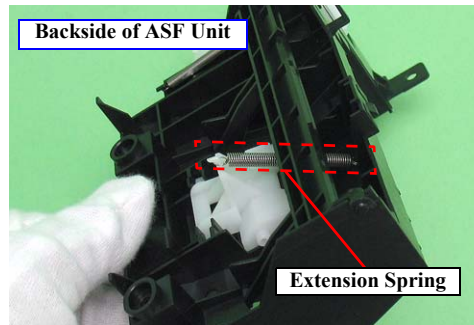


Table 3-7. Check point for Ink out error / No ink cartridge error read error / write error according to each phenomenon

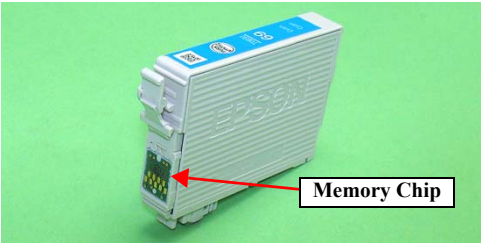
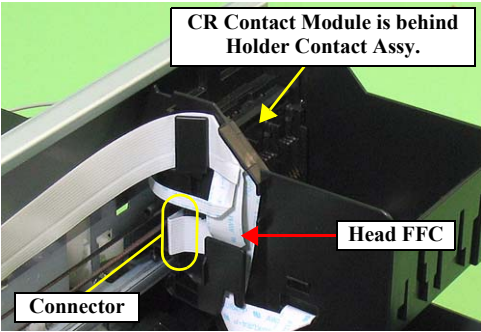
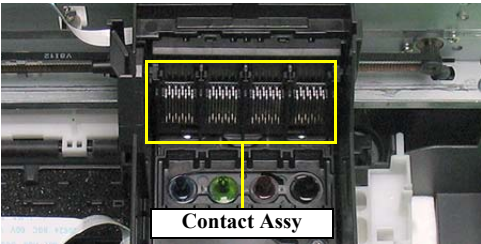
Occurrence timing CR position	Detailed phenomenon	Defective unit/part name	Check point	Remedy
<ul style="list-style-type: none"> • Power on • Inside HP 	After the printer detects that the carriage is at the home position, an error is displayed.	Ink Cartridge	<ol style="list-style-type: none"> 1. Check if Ink Cartridge is properly installed. 2. Check if the Memory Chip is disconnected or chipped. 	<ol style="list-style-type: none"> 1. Install the Ink Cartridge properly. 2. Replace the Ink Cartridge with a new one.
		CR Contact Module	<ol style="list-style-type: none"> 1. Check if the Head FFC is connected correctly to the connector on the CR Contact Module. 	<ol style="list-style-type: none"> 1. Connect the Head FFC to the connector on the CR Contact Module.
		Contact Assy	<ol style="list-style-type: none"> 2. Check if the CSIC Board is damaged. 3. Check if the Contact Assy is damaged. 	<ol style="list-style-type: none"> 2. Replace the CR Contact Module with a new one. 1. Replace the Contact Assy with a new one.

Table 3-8. Check point for Communication error according to each phenomenon

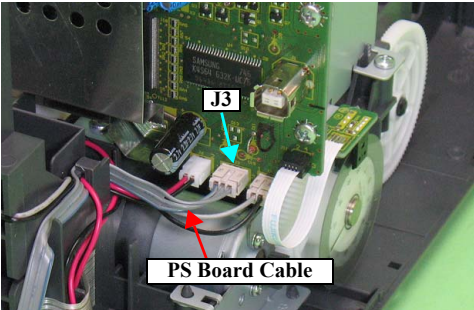
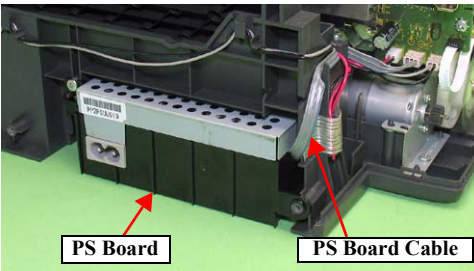
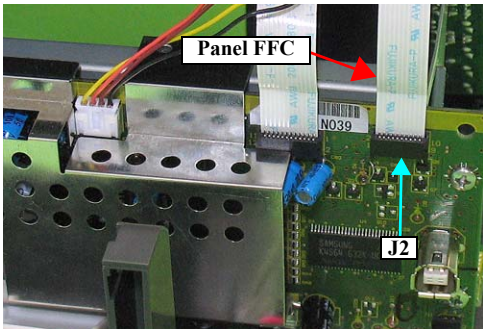
Occurrence timing CR position	Detailed phenomenon	Defective unit/part name	Check point	Remedy
<ul style="list-style-type: none"> • Power on • Anywhere 	When turning on the power, the printer does not operate at all.	Panel Unit	1. Check if the Panel FFC is damaged.	1. Replace the Panel Board with a new one.
			2. Check if the Panel Board is damaged.	2. Replace the Panel Board with a new one.
		PS Board Unit	1. Check if the PS Board Cable is connected correctly to J3 on the Main Board. 	1. Connect the PS Board Cable to J3 on the Main Board.
			2. Check if the PS Board Cable/PS Board is damaged. 	2. Replace the PS Board Unit with a new one. * If the problem is not solved, replace the Main Board with a new one.

Table 3-8. Check point for Communication error according to each phenomenon

Occurrence timing CR position	Detailed phenomenon	Defective unit/part name	Check point	Remedy
<ul style="list-style-type: none"> • Power on • – 	When turning on the power, the power on sequence is performed correctly. But, when any printer job is sent to the printer, a communication error is indicated with STM3.	USB Cable	1. Check if the USB Cable is connected between the printer and the PC.	1. Connect the USB Cable to the printer and the PC.
		Main Board	1. Check if an correct model name is stored into the address of the EEPROM on the Main Board. 2. Check if the Panel FFC is connected to J2 on the Main Board.	

3.2.2 Superficial Phenomenon-Based Troubleshooting

This section explains the fault locations of the error states (print quality and abnormal noise) other than the error states (LED and STM3) in the previous section.

Table 3-9. Check point for the error that multiple sheets of paper are always loaded without LEDs and STM3

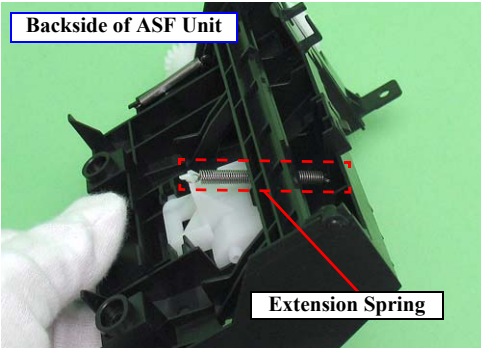
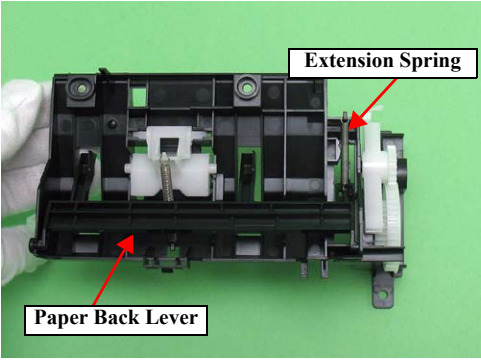
Occurrence timing CR position	Detailed phenomenon	Defective unit/part name	Check point	Remedy
<ul style="list-style-type: none"> • Operation • – 	<p>The LEDs and STM3 are not indicating error conditions. But, multiple sheets of paper are always loaded from the ASF Unit.</p>	<p>ASF Unit</p>	<p>1. Check if the Extension Spring operates correctly in the paper loading sequence.</p>  <p>2. Check if the Paper Back Lever operates correctly in the paper loading sequence.</p> 	<p>1. Set the Extension Spring between the Retard Roller Assy and the ASF Housing.</p> <p>2. Set the Extension Spring between the ASF Housing and the Paper Back Lever.</p>

Table 3-10. Check point for the abnormal noise

Occurrence timing CR position	Detailed phenomenon	Defective unit/part name	Check point	Remedy
<ul style="list-style-type: none"> • Anytime • Anywhere 	The abnormal noise occurs at the first power on timing and during each operation although the printing operation is performed.	Carriage Unit	1. Check if the grease on the Carriage Path is sufficient. (TBD)	1. Wipe off the remaining grease on the Carriage path and lubricate it on its frame. (TBD)
		ASF Unit	1. Check if the Change Lever moves smoothly.	1. Replace the ASF Unit with a new one.
	The bottom of the Carriage Unit contacts the surface of the EJ Frame Assy.	EJ Frame Assy	1. Check if the EJ Frame Assy is bent up.	1. Replace the EJ Frame Assy with a new one.
	The Carriage Unit collides to the Upper Paper Guide Unit during each operation.	Upper Paper Guide	1. Check if the Upper Paper Guide is attached securely. (check if it interferes with the Carriage Unit)	1. Reassemble the Upper Paper Guide to the Main Frame.

Table 3-11. Check point for the defective scanned image quality

Print Quality State	Detailed phenomenon	Defective unit/part name	Check point	Remedy
<ul style="list-style-type: none"> • Scanned image is not clear. 	There are dusts or the like on the Document Glass. (white dots appear on the scanned image)	Upper Scanner Housing	1. Check if there is foreign material on the Document Glass.	1. Remove the foreign material from the Document Glass. (Refer to Chapter 6 “MAINTENANCE” (p.108).)
	There are dusts or the like on the LED inside the Rod Lens Array. (vertical stripes appear on the scanned image)	CIS Unit	1. Check if there is foreign material on the LED.	1. Remove the foreign material from the CIS Unit. (blow away the dusts)
			2. Check if the Rod Lens Array is damaged.	2. Replace the CIS Unit with a new one.
The LED of Scanner CIS Unit does not light up.	CIS Unit	1. Check if the LED lights up.	1. Replace the CIS Unit with a new one.	

Table 3-12. Check point for the defective printing quality

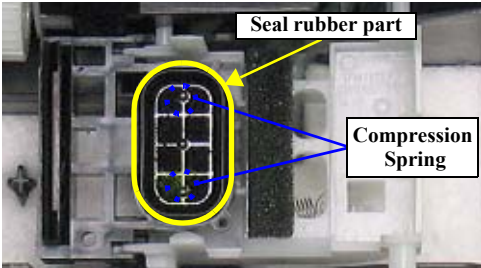
Print Quality State	Detailed phenomenon	Defective unit/part name	Check point	Remedy
• Dot missing and mixed colors	Ink is scarcely ejected to the Cap from the Printhead.	Cap Assy	1. Check if there is not any foreign material/damage around the seal rubber part on the Cap Assy. 	1. Remove the foreign material around the seal rubber parts carefully.
			2. Check if the Compression Spring is correctly mounted on the Cap Assy.	2. Replace the Cap Assy with a new one.
	Ink is ejected to the Cap from the Printhead, but the printer does not recover from the error after cleaning or ink change.	Printhead	1. Check if it returns to normal by performing CL operation or replacing the Ink Cartridge. 2. Check if the Printhead is damaged.	1. Perform CL operation and the Ink Cartridge replacement specified times. If it doesn't work, change the Printhead with a new one. 2. Replace the Printhead with a new one.
		Cleaner Blade	1. Check if the Cleaner Blade has paper dust or bending.	1. Replace the Cap Assy with a new one.
		Ink System	1. Check the routing of the Waste Ink Tube.	1. Route the Waste Ink Tube correctly.
			2. Check if the Pump Assy is correctly assembled.	2. Reassemble the Pump Assy correctly.
		Main Board	1. Check if the Main Board is damaged.	1. Replace the Main Board with a new one.

Table 3-12. Check point for the defective printing quality

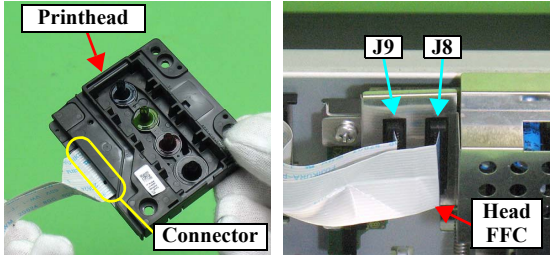
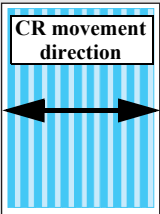
Print Quality State	Detailed phenomenon	Defective unit/part name	Check point	Remedy
• White streak / abnormal discharge	Ink is ejected to the Cap from the Printhead, but printing is not done at all after cleaning or ink change, or abnormal discharge occurs.	Head FFC	1. Check if the Head FFC is securely connected to the Printhead Connectors and the Main Board Connectors. (J8, J9) 	1. Connect the Head FFC to the Printhead and the Main Board Connectors.
			2. Check if the Head FFC is damaged.	2. Replace the Head FFC with a new one.
		Printhead	1. Check if it returns to normal by performing CL operation or replacing the Ink Cartridge.	1. Perform CL operation and the Ink Cartridge replacement specified times. If it doesn't work, change the Printhead with a new one.
		Main Board Unit	1. Check if the Main Board is damaged.	1. Replace the Main Board Unit with a new one.
• White streak / color unevenness occurrence	Vertical banding appears against the CR movement direction. And, it looks like uneven printing. 	Adjustment	1. For printing in the Bi-D mode, check if Bi-D Adjustment has been performed properly.	1. Perform Bi-D Adjustment to correct print start timing in bi-directional printing. (Refer to Chapter 5 "ADJUSTMENT" (p.100).)
		Printhead	1. Check if the Nozzle Check Pattern is printed properly.	2. Perform Head Cleaning and check the Nozzle Check Pattern. (Refer to Chapter 5 "ADJUSTMENT" (p.100).) If the problem is not solved, replace the Printhead with a new one.
		Main Frame	1. Check if there is any foreign material on the Carriage path.	1. Remove foreign material from surface of the Carriage path.
			2. Check if the Main Frame is deformed.	2. Replace the Main Frame with a new one.
	[Note] If the problem is not solved, replace the CR Motor with a new one.	3. Check if the grease is enough on the Carriage path of the Main Frame. (TBD)	3. After wiping the grease G-71 on the Carriage path with a dry, soft cloth, coat it with grease. (Refer to Chapter 6 "MAINTENANCE" (p.108).) (TBD)	
		EJ Frame Assy	1. Check if the EJ Frame is deformed.	1. Replace the EJ Frame Assy with a new one.

Table 3-12. Check point for the defective printing quality

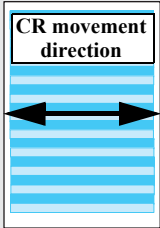
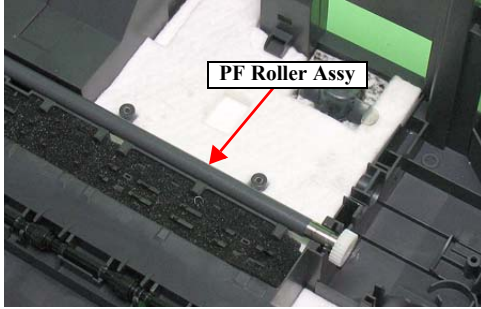
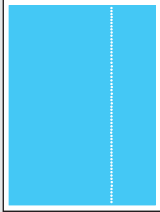
Print Quality State	Detailed phenomenon	Defective unit/part name	Check point	Remedy	
<ul style="list-style-type: none"> White streak / color unevenness occurrence 	Micro banding appears horizontally against the CR movement direction and it appears with the same width.  [Note] If the problem is not solved, replace the PF Motor with a new one.	Printer driver & exclusive paper	1. Check if the suitable paper is used according to the printer driver setting.	1. Use the suitable paper according to the printer driver setting.	
		Printhead	1. Check if the Nozzle Check Pattern is printed correctly.	1. Perform the Head Cleaning and check the Nozzle Check Pattern. (Refer to Chapter 5 "ADJUSTMENT" (p.100).) If the problem is not solved, replace the Printhead with a new one.	
		PF Roller Assy	1. Check if there is foreign material on the surface of the PF Roller Assy.		1. Clean the surface of the PF Roller Assy carefully with the soft cloth.
	The Star wheel mark against the CR movement direction.		EJ Frame Assy	1. Check if the Wheel Star Metal and Spring Star Wheel does not come off.	1. Reassemble the Wheel Star Metal and Spring Star Wheel correctly.
				2. Check if the surface of the EJ Frame Assy is flat.	2. Replace the EJ Frame Assy with a new one.
	Printing is blurred.		Printer driver & exclusive paper	1. Check if the suitable paper is used according to the printer driver setting.	1. Use the suitable paper according to the printer driver setting.
Printhead			1. Check if the correct Head ID is stored into the EEPROM by using the Adjustment Program.	1. Input 11-digit code of the Head ID into the EEPROM by using the Adjustment Program.	

Table 3-12. Check point for the defective printing quality

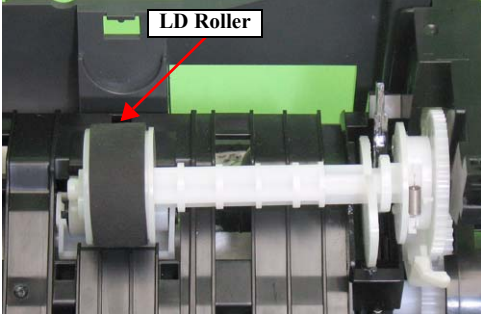
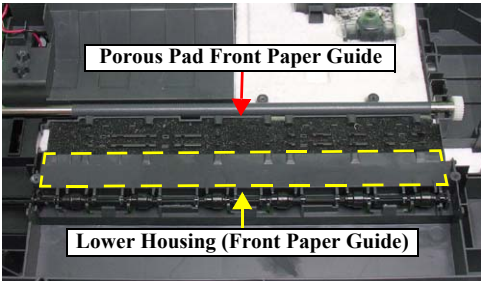
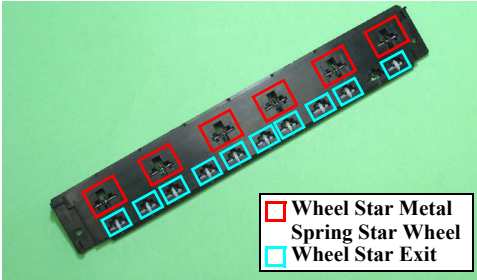
Print Quality State	Detailed phenomenon	Defective unit/part name	Check point	Remedy
• Print start position slip	The printing operation is correctly performed. But, the top margin is insufficient than usual one.	LD Roller	<p>1. Check if paper dust is adhered to the surface of the LD Roller.</p> 	<p>1. Set a cleaning sheet in the ASF up side down. Then holding the top edge, try to load the paper from the Printer driver. The micro pearl on the LD Roller surface is removed. To remove severe smear, staple a cloth moistened with alcohol to a post card and clean the roller in the same manner. As for the cleaning sheet, refer to “Check point for Paper out error according to each phenomenon” (p.40).</p> <p>* If the problem is not solved, replace the ASF Unit with a new one.</p>
• Ink stain of paper	Ink stain occurs at the back, top end or bottom end of the print paper.	Lower Housing	<p>1. Check if the Lower Housing is free from ink stain.</p> 	1. Clean the Lower Housing with a soft cloth.
			<p>2. Check if heaps of ink are formed on Porous Pad Front Paper Guide.</p>	2. Replace the Lower Housing with a new one.
		EJ Roller Assy	1. Check if the EJ Frame Assy is free from ink stain.	1. Clean the EJ Frame Assy with a soft cloth.
PF Roller Assy	1. Check if the PF Roller Assy is free from ink stain.	1. Clean the PF Roller Assy with a soft cloth.		

Table 3-12. Check point for the defective printing quality

Print Quality State	Detailed phenomenon	Defective unit/part name	Check point	Remedy
• Ink stain of paper	Ink sticks to other than the print area of the paper, resulting in contamination.	Printhead	1. Check if the Printhead Cover has the ink drop.	1. Clean the Printhead Cover carefully with a soft cloth.
		Upper Paper Guide	1. Check if the Upper Paper Guide Unit is free from ink stain.	1. Clean the Upper Paper Guide Unit with a soft cloth.
		EJ Frame Assy	2. Check if the Wheel Star Metal, Spring Star Wheel and Wheel Star Exit come off. 	2. Reassemble the Wheel Star Metal, Spring Star Wheel and Wheel Star Exit correctly.

3.2.3 Motor and Sensor Troubleshooting

□ Motors

The resistance values for the CR motor and the PF motor are given below, however, the values cannot be used to check the motors status since they are DC motor and the resistance between the electric poles varies. Visually check the motors for abnormal operation and if it is hard to judge, replace the motor.

Table 3-13. Sensor check point

Motor	Motor Type	Drive Voltage	Resistance
CR motor	DC motor with brush	DC 42V \pm 5%	TBD
PF motor			TBD
Scanner motor	TBD		TBD

CHAPTER

4

DISASSEMBLY/ASSEMBLY

4.1 Overview

This section describes procedures for disassembling the main components of Epson STYLUS NX100/NX105/SX100/SX105/TX100/TX101/TX102/TX103/TX105/TX106/TX109/ME 300. Unless otherwise specified, disassembled units or components can be reassembled by reversing the disassembly procedure. Procedures which, if not strictly observed, could result in personal injury are described under the heading “WARNING”. “CAUTION” signals a precaution which, if ignored, could result in damage to equipment. Important tips for procedures are described under the heading “CHECK POINT”. If the assembly procedure is different from the reversed disassembly procedure, the correct procedure is described under the heading “REASSEMBLY”. Any adjustments required after reassembly of components or parts are described under the heading “ADJUSTMENT REQUIRED”. When you have to remove any components or parts that are not described in this chapter, refer to the exploded diagrams in the appendix.

Read the following precautions before disassembling and assembling.

4.1.1 Precautions

See the precautions given under the heading “WARNING” and “CAUTION” in the following columns when disassembling or assembling Epson STYLUS NX100/NX105/SX100/SX105/TX100/TX101/TX102/TX103/TX105/TX106/TX109/ME 300.



- **Disconnect the power cable before disassembling or assembling the printer.**
- **If you need to work on the printer with power applied, strictly follow the instructions in this manual.**
- **Always wear gloves for disassembly and reassembly to protect your eyes from ink. If any ink gets in your eyes, wash your eyes with clean water and consult a doctor immediately.**
- **Always wear gloves for disassembly and reassembly to avoid injury from sharp metal edges.**
- **To protect sensitive microprocessors and circuitry, use static discharge equipment, such as anti-static wrist straps, when accessing internal components.**
- **Never touch the ink or wasted ink with bare hands. If ink comes into contact with your skin, wash it off with soap and water immediately. If you have a skin irritation, consult a doctor immediately.**



- **When transporting the printer after installing the ink cartridge, pack the printer for transportation without removing the ink cartridge and be sure to secure the Ink Cartridge to the printer cover with tape tightly to keep it from moving.**
- **Use only recommended tools for disassembling, assembling or adjusting the printer.**
- **Observe the specified torque when tightening screws.**
- **Apply lubricants as specified. (See Chapter 6 “MAINTENANCE” (p108) for details.)**
- **Make the specified adjustments when you disassemble the printer. (See Chapter 5 “ADJUSTMENT” (p100) for details.)**
- **When reassembling the Waste Ink Tube, make sure that the tip of waste ink tube is placed in the correct position, otherwise ink may leak.**
- **When using compressed air products; such as air duster, for cleaning during repair and maintenance, the use of such products containing flammable gas is prohibited.**

4.1.2 Tools

Use only specified tools to avoid damaging the printer.

Table 4-1. Tools

Name	EPSON Tool Code*
(+) Phillips screwdriver #1	1080530
(+) Phillips screwdriver #2	---
Flathead Precision screwdriver #1	---
Tweezers	---
Longnose pliers	---

Note *: All of the tools listed above are commercially available. EPSON provides the tools listed with EPSON tool code.

4.1.3 Work Completion Check

If any service is made to the printer, use the checklist shown below to confirm all works are completed properly and the printer is ready to be returned to the user.

Table 4-2. Work Completion Check

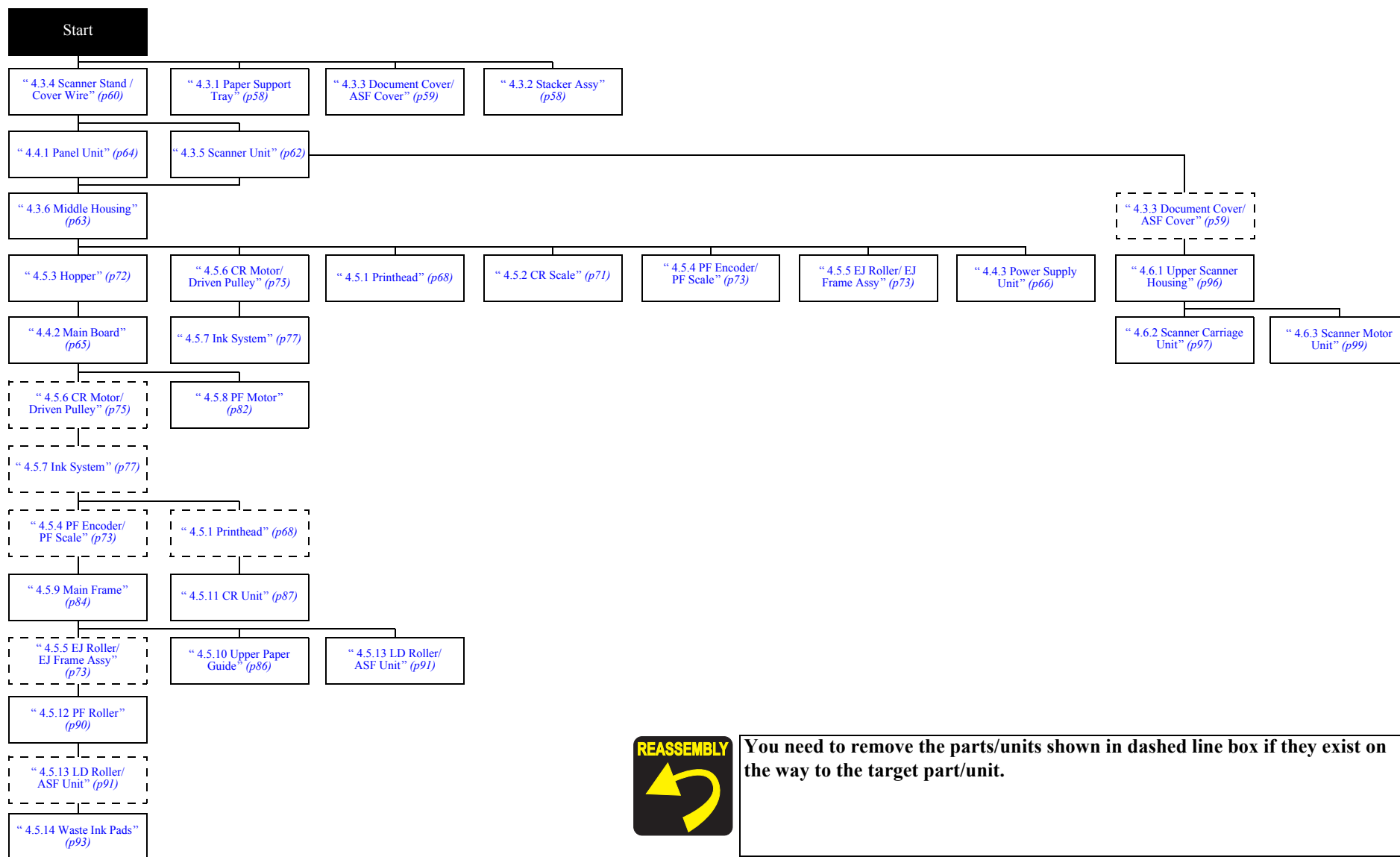
Classification	Item	Check Point	Status
Printer Unit	Self-test	Is the operation normal?	<input type="checkbox"/> OK / <input type="checkbox"/> NG
	ON-line Test	Is the printing successful?	<input type="checkbox"/> OK / <input type="checkbox"/> NG
	Printhead (Nozzle check pattern print)	Is ink discharged normally from all the nozzles?	<input type="checkbox"/> OK / <input type="checkbox"/> NG
	Carriage Mechanism	Does it move smoothly?	<input type="checkbox"/> OK / <input type="checkbox"/> NG
		Is there any abnormal noise during its operation?	<input type="checkbox"/> OK / <input type="checkbox"/> NG
		Is the CR Motor at the correct temperature? (Not too hot to touch?)	<input type="checkbox"/> OK / <input type="checkbox"/> NG
	Paper Feeding Mechanism	Is paper advanced smoothly?	<input type="checkbox"/> OK / <input type="checkbox"/> NG
		No paper jamming?	<input type="checkbox"/> OK / <input type="checkbox"/> NG
		No paper skew?	<input type="checkbox"/> OK / <input type="checkbox"/> NG
		No multiple feeding?	<input type="checkbox"/> OK / <input type="checkbox"/> NG
		No abnormal noise?	<input type="checkbox"/> OK / <input type="checkbox"/> NG
		Is the paper path free of any obstructions?	<input type="checkbox"/> OK / <input type="checkbox"/> NG
		Is the PF Motor at correct temperature?	<input type="checkbox"/> OK / <input type="checkbox"/> NG

Table 4-2. Work Completion Check

Classification	Item	Check Point	Status
Scanner unit	Mechanism	Is glass surface dirty?	<input type="checkbox"/> OK / <input type="checkbox"/> NG
		Is any foreign substance mixed in the CR movement area?	<input type="checkbox"/> OK / <input type="checkbox"/> NG
	CR mechanism	Does CR operate smoothly?	<input type="checkbox"/> OK / <input type="checkbox"/> NG
		Does CR operate together with scanner unit?	<input type="checkbox"/> OK / <input type="checkbox"/> NG
	LED	Does CR make abnormal noise during its operation?	<input type="checkbox"/> OK / <input type="checkbox"/> NG
		Does LED turn on normally? And is white reflection test done near home position?	<input type="checkbox"/> OK / <input type="checkbox"/> NG
ON-line Test	ON-line Test	Is the operation normal?	<input type="checkbox"/> OK / <input type="checkbox"/> NG
Copy	Copy	Is the local copy action normal?	<input type="checkbox"/> OK / <input type="checkbox"/> NG
Adjustment	Specified Adjustment	Are all the adjustment done correctly	<input type="checkbox"/> OK / <input type="checkbox"/> NG
Lubrication	Specified Lubrication	Are all the lubrication made at the specified points?	<input type="checkbox"/> OK / <input type="checkbox"/> NG
		Is the amount of lubrication correct?	<input type="checkbox"/> OK / <input type="checkbox"/> NG
Function	ROM Version	Version:	<input type="checkbox"/> OK / <input type="checkbox"/> NG
Packing	Ink Cartridge	Are the ink cartridges installed correctly?	<input type="checkbox"/> OK / <input type="checkbox"/> NG
	Waste Ink pad	Are the waste ink pads adequate to absorb?	<input type="checkbox"/> OK / <input type="checkbox"/> NG
	Protective materials	Is the printer carriage placed at the capping position?	<input type="checkbox"/> OK / <input type="checkbox"/> NG
Others	Attachments, Accessories	Have all the relevant items been included in the package?	<input type="checkbox"/> OK / <input type="checkbox"/> NG

4.2 Disassembly Procedures

For disassembling each unit, refer to the pages in the following flowchart.



You need to remove the parts/units shown in dashed line box if they exist on the way to the target part/unit.

Figure 4-1. Disassembling Flowchart

4.3 Removing the Housing

4.3.1 Paper Support Tray

- Parts/Components need to be removed in advance:
None
- Removal procedure
 1. Open the Paper Support Tray.
 2. Release both the guide pins that secure the Paper Support Tray, and remove the Paper Support Tray.

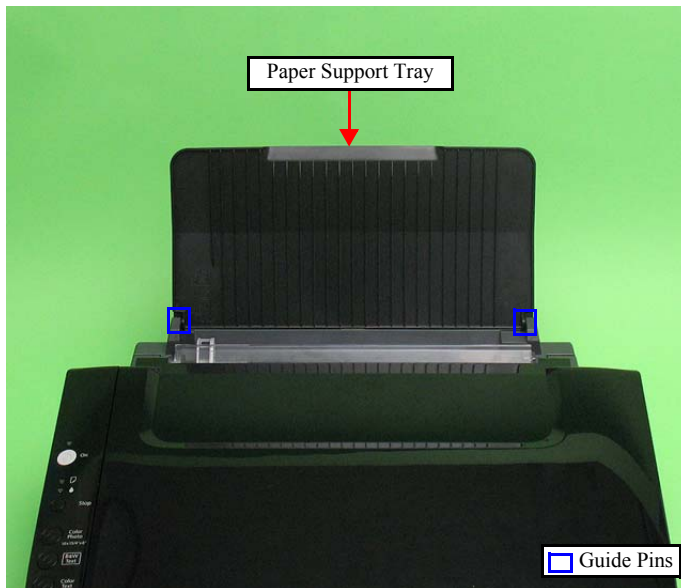


Figure 4-2. Removing the Paper Support Tray

4.3.2 Stacker Assy

- Parts/Components need to be removed in advance:
None
- Removal procedure
 1. Open the Stacker Assy and pull it out.
 2. Release both the guide pins that secure the Stacker Assy, and remove the Stacker Assy.

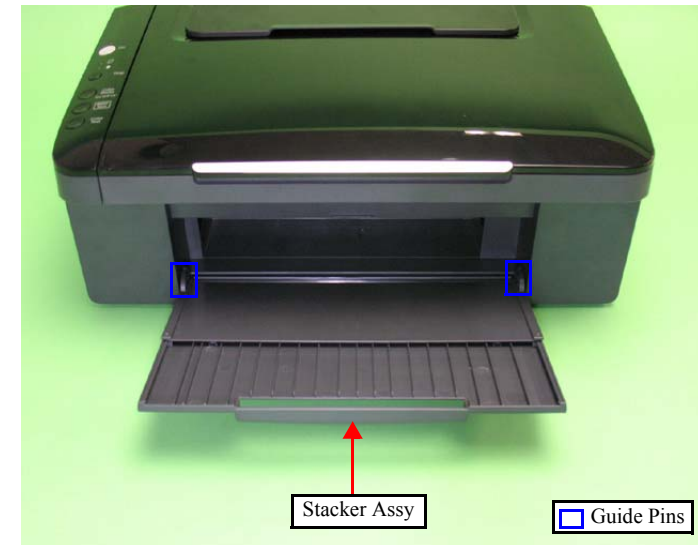


Figure 4-3. Removing the Stacker Assy (1)

- Bend the Stacker Assy to release the ribs, then separate the Tray Exit Outer and the Tray Exit Inner.

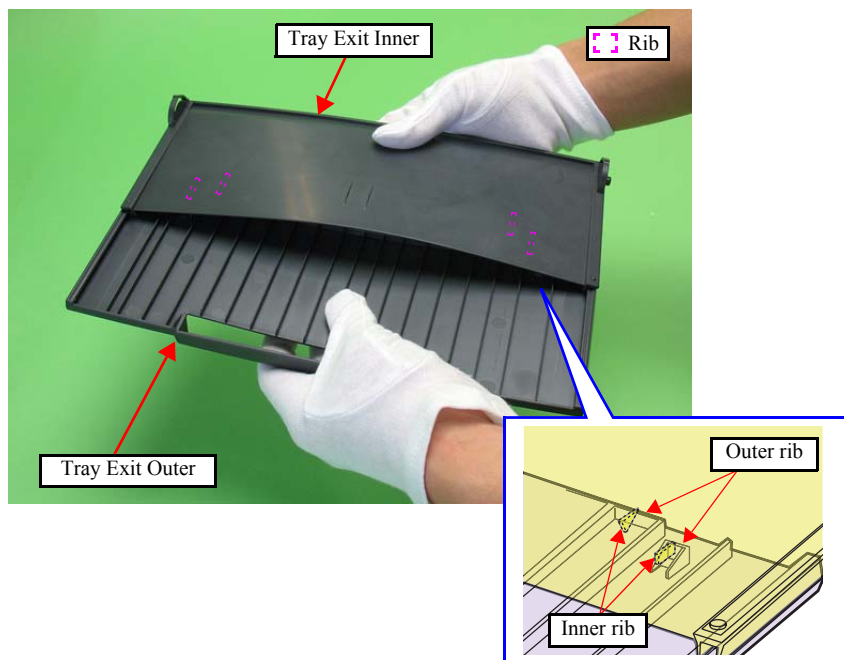


Figure 4-4. Removing the Stacker Assy (2)

REASSEMBLY



Align the edges of the Tray Exit Outer and the Tray Exit Inner, and attach them together. Then, engage the inner ribs with the outer ones.

4.3.3 Document Cover/ASF Cover

- Parts/Components need to be removed in advance: None
- Removal procedure
 - Release both the guide pins with the hinge side held up slightly as shown below, and remove the ASF Cover from the Document Cover.

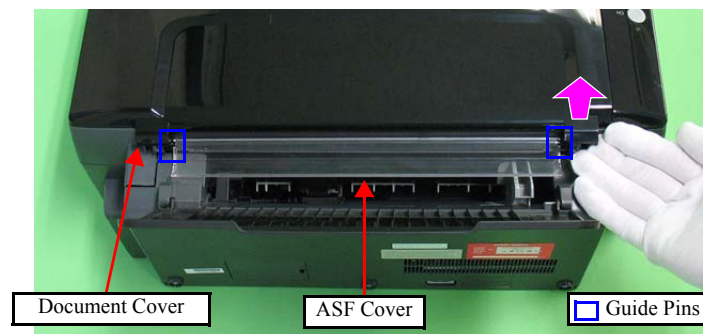


Figure 4-5. Removing the ASF Cover

- Open the Document Cover.
- Release both the other guide pins that secure the Document Cover, and remove the Document Cover from the Scanner Unit.



Figure 4-6. Removing the Document Cover

REASSEMBLY

Install the Document Pad following the procedure below.

1. Place the Document Pad with the side where the double-sided tape attached upward on the Rod Lens Array aligning its corner with the home position.
2. Close the Document Cover to attach the Document Pad.

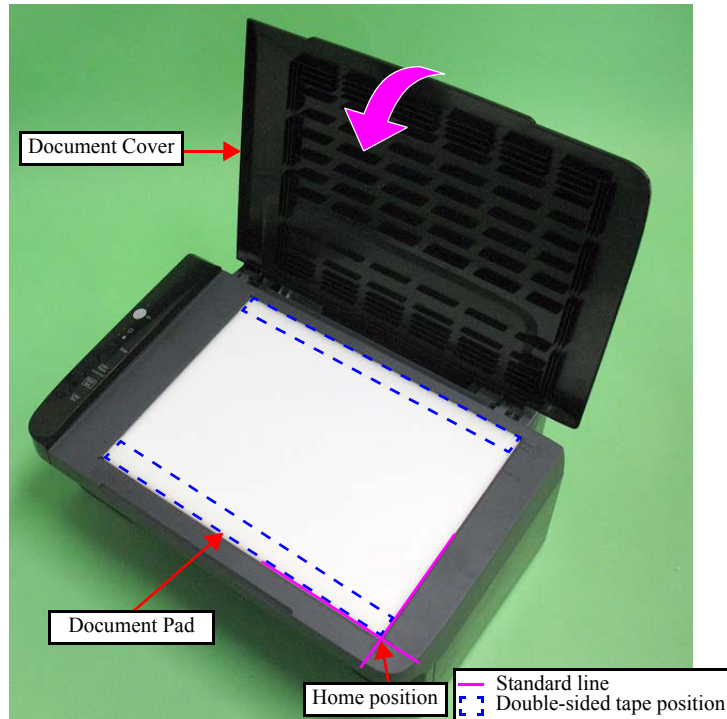


Figure 4-7. Document Pad Position

4.3.4 Scanner Stand /Cover Wire

- Parts/Components need to be removed in advance: None
- Removal procedure
 - Scanner Stand
 1. Open the Scanner Unit.
 2. Release the hooks (x2) at the lower part of the Scanner Stand.

CAUTION

Be careful not to lose the Scanner Stand Spring when removing the Scanner Stand.

3. Release the guide pins (x2) at the upper part of the Scanner Stand, and remove the Scanner Stand.

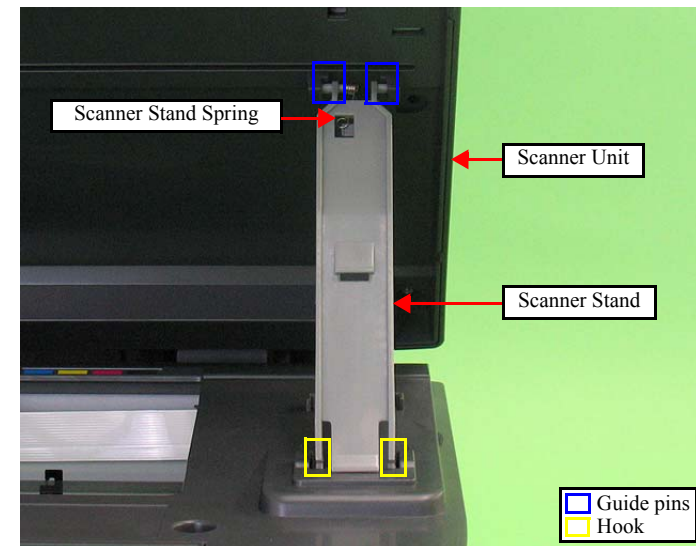


Figure 4-8. Removing the Scanner Stand

■ Cover Wire

1. Open the Scanner Unit.
2. Release both the hooks in the direction of arrow, and remove the Cover Wire.

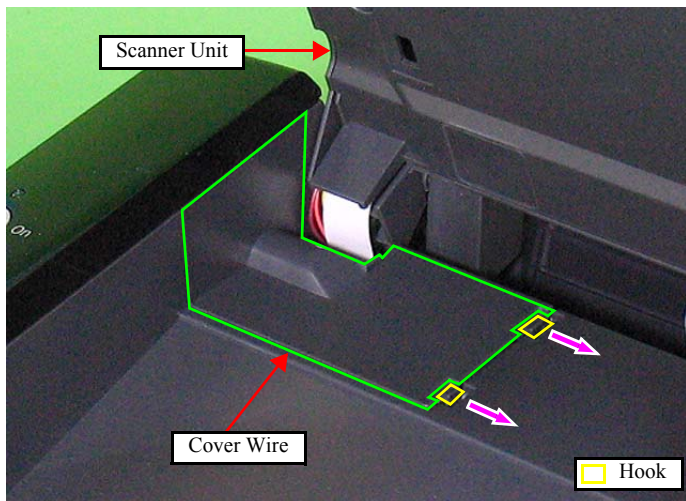


Figure 4-9. Removing the Cover Wire



When installing the Scanner Stand, secure the shorter leg of the Scanner Stand Spring to the groove on the Scanner Unit, and secure the longer to the hook of the Scanner Stand as shown below.

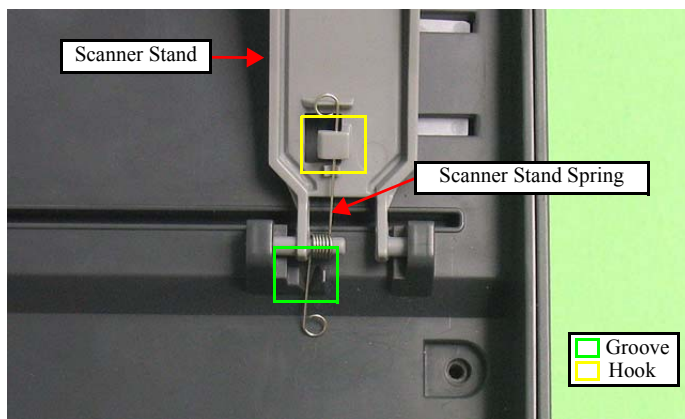


Figure 4-10. Installing the Scanner Stand



- Make sure not to catch the Scanner Motor Cable and the Scanner FFC with the Cover Wire.
- When installing the Cover Wire, insert the rib B so as to let the rib A of the Cover Wire under the Panel FFC.

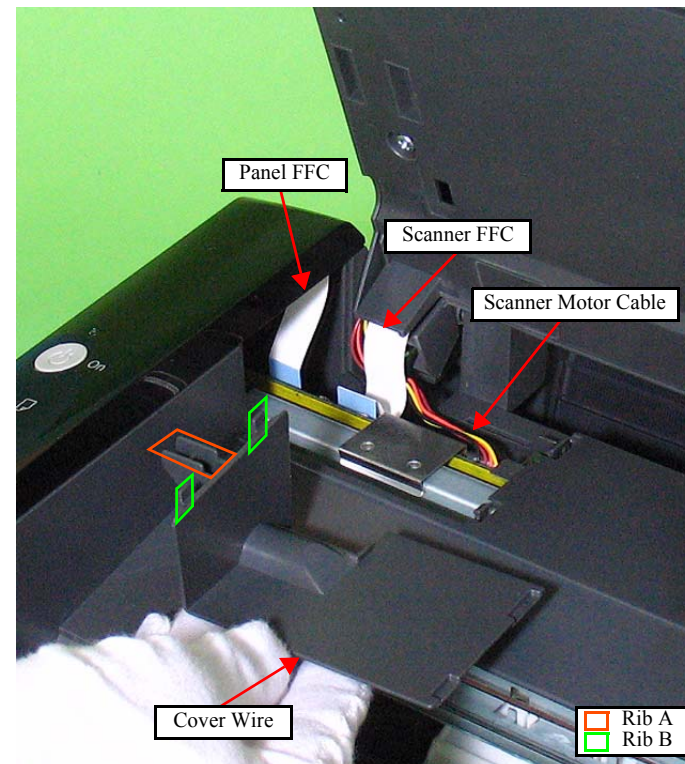


Figure 4-11. Installing the Cover Wire

4.3.5 Scanner Unit

- Parts/Components need to be removed in advance:
Scanner Stand/Cover Wire (p60)
- Removal procedure

CAUTION



When removing the FFC and the cable from the connectors as shown below, make sure to pull up the cables from the connectors on the Main Board, otherwise, it may get damaged.

1. Open the Scanner Unit to the full, disconnect the Scanner FFC and the Scanner Motor Cable from connectors J4, J5 on the Main Board.

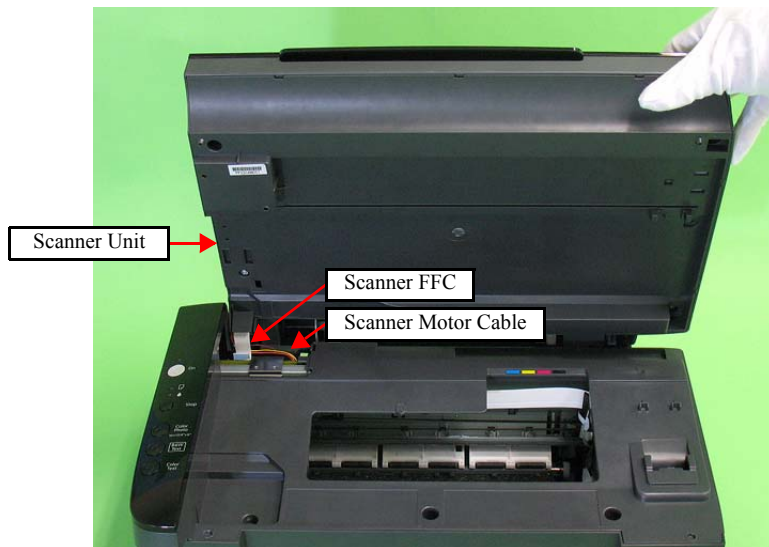


Figure 4-12. Removing the Scanner Unit (1)

2. Lift the left end of the Scanner Unit in the direction of arrow (1), then disengage the dowel from the cutout of the shaft hole in the Scanner Unit.
3. Pull the Scanner Unit in the direction of arrow (2) and disengage the dowel from the shaft hole, then remove the Scanner Unit from the Middle Housing.

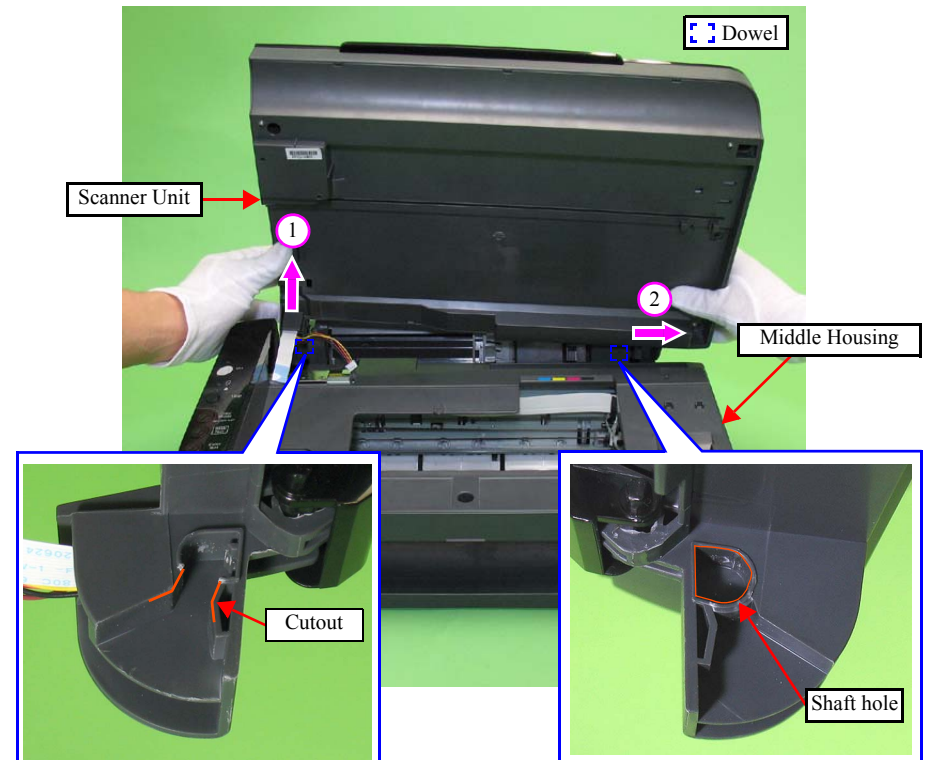


Figure 4-13. Removing the Scanner Unit (2)

REASSEMBLY



Install the Scanner Unit as follows. (See Fig.4-13)

1. Insert the right Shaft Hole of the Scanner Unit to the right dowel of the Middle Housing aligning their shapes.
2. Insert the left dowel of the Lower Housing to the cutout of the left shaft hole on the Scanner Unit, and push the unit until the left dowel is secured into the shaft hole.
3. Connect the Scanner FFC and the Scanner Motor Cable to connectors J4, J5 on the Main Board.

4.3.6 Middle Housing

- Parts/Components need to be removed in advance:
Scanner Stand/Cover Wire (p 60), Scanner Unit (p 62), Panel Unit (p 64)
- Removal procedure
 1. Remove the six screws.

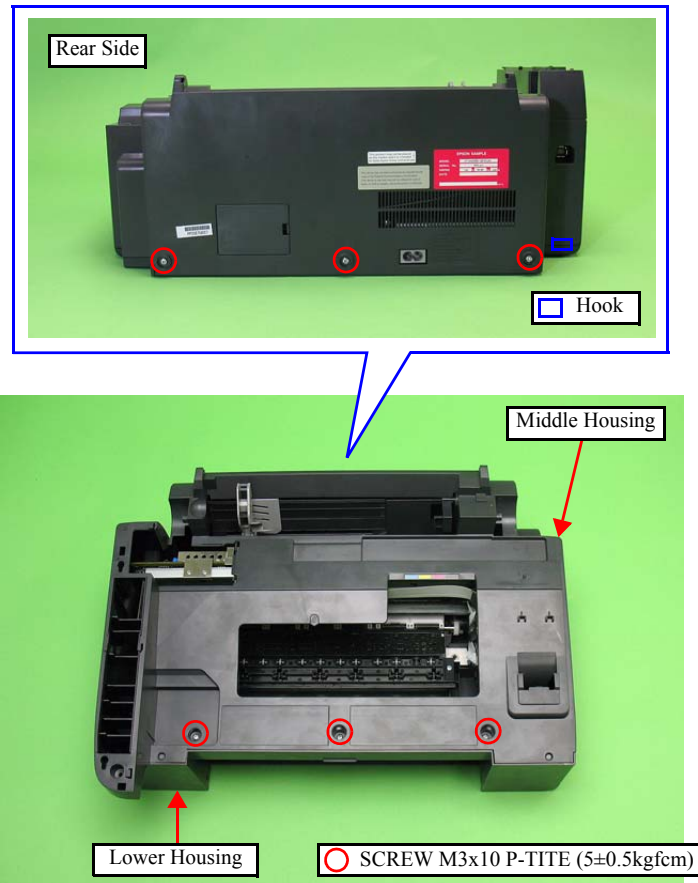


Figure 4-14. Removing the Middle Housing (1)

2. Release the two hooks on the left, two hooks on the right, and the hook on the rear (see Fig.4-14), then remove the Middle Housing from the Lower Housing.

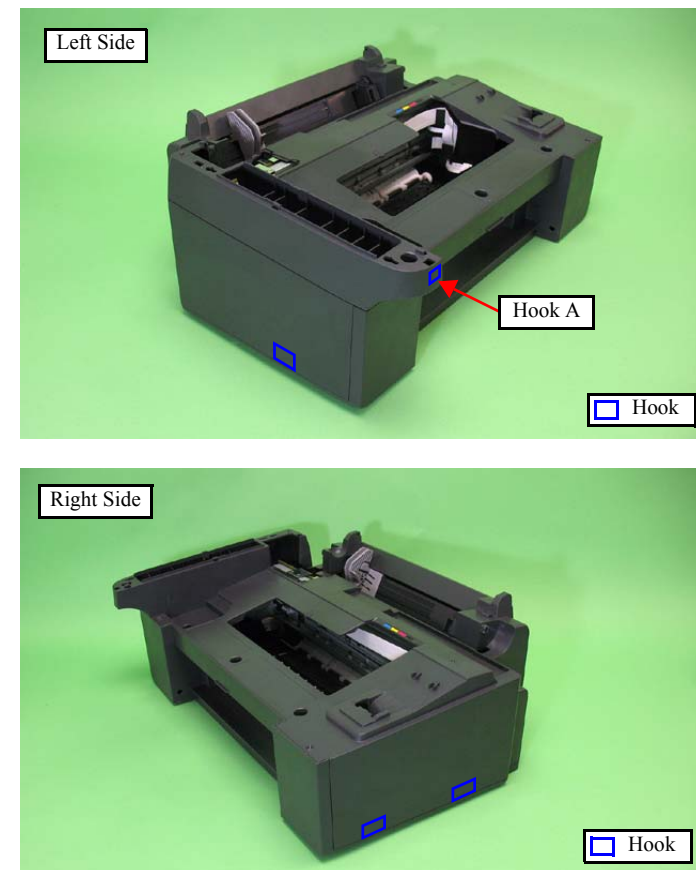


Figure 4-15. Removing the Middle Housing (2)



When installing the Middle Housing, first align the hook A on the front left, and then attach the housing. (See Fig.4-15.)

4.4 Removing the Circuit Boards

4.4.1 Panel Unit

- Parts/Components need to be removed in advance:
Scanner Stand/Cover Wire (p60)

- Removal procedure

1. Open the Scanner Unit.

CAUTION



- Be careful when removing the Panel Unit, because the Main Board and the Panel Board on the rear of the Panel Unit are connected with the Panel FFC.
- Be careful when carrying out the next procedure, because the hook on the rear of the Panel Unit is fragile and easily gets damaged or softened.

2. Slide the Panel Unit back with lifting the rear side slightly. And remove the Panel Unit.

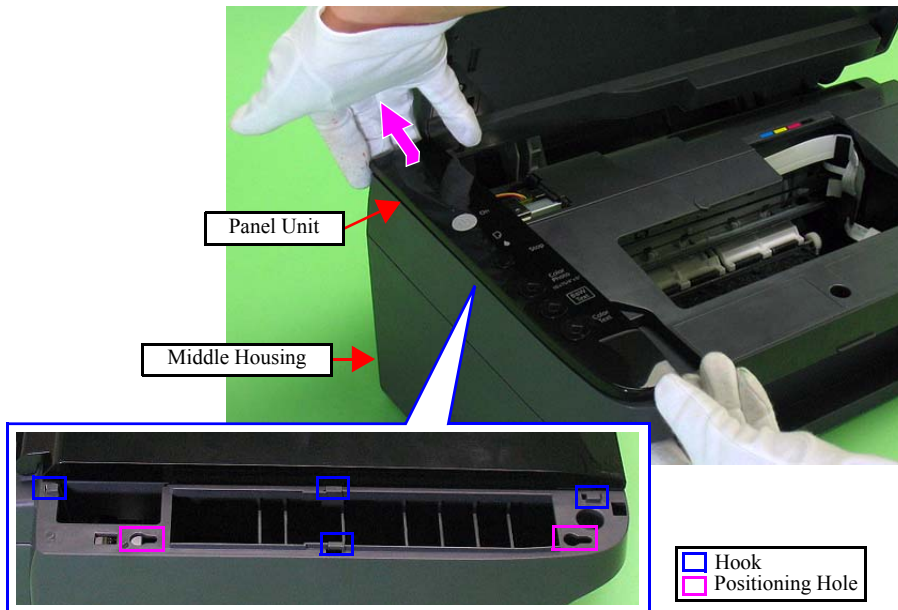


Figure 4-16. Removing the Panel Unit (1)

3. Disconnect the Panel FFC from connector J2 on the Main Board, and remove the Panel Unit.

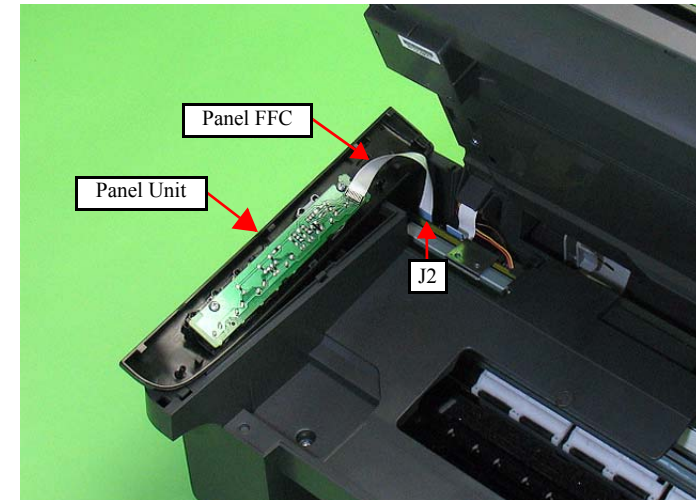


Figure 4-17. Removing the Panel Unit (2)

- Disassembling the Panel Unit

- Panel Board

1. Remove the two screws that secure the Panel Board.
2. Release the two hooks, and remove the Panel Board from the Panel Unit.

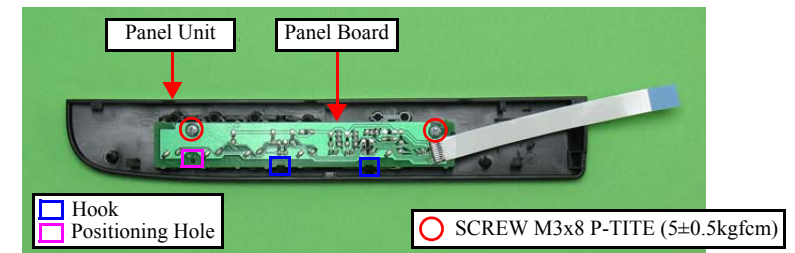


Figure 4-18. Removing the Panel Board

■ Buttons

1. Remove the Button Power and the Button OP from the Panel Cover.
2. Remove the LED Lens from the Panel Cover.

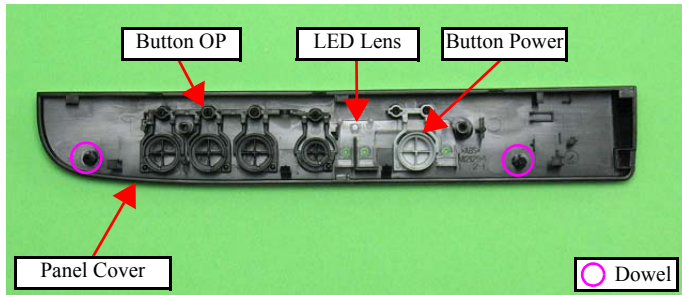


Figure 4-19. Removing the Buttons

REASSEMBLY



- When installing the Panel Board, align the positioning hole of the Panel Board with the dowels of the Panel Cover. (See [Fig.4-18](#))
- When installing the Panel Unit, align the positioning holes of the Middle Housing with the dowels of the Panel Cover, then secure them with four hooks. (See [Fig.4-16](#), [Fig.4-19](#).)

4.4.2 Main Board

- Parts/Components need to be removed in advance:
Scanner Stand/Cover Wire ([p60](#)), Scanner Unit ([p62](#)), Middle Housing ([p63](#))
Panel Unit ([p64](#)), Hopper ([p72](#))
- Removal procedure
 1. Remove all the cables and FFCs connected to the Main Board.

CN No	Cable	Cable Color	Connector Color	Pins
J2	Panel FFC	---	Black	10
J3	Power Supply Unit cable	Gray	Brown	3
J4	Scanner FFC	---	Black	12
J5	Scanner Motor Cable	Black,Brown, Orange,Yellow	White	4
J6	PF Motor Cable	Red, Black	White	2
J7	CR Motor Cable	Gray, Black	Brown	2
J8	Head FFC	---	Black	21
J9	FFC	---	Black	17

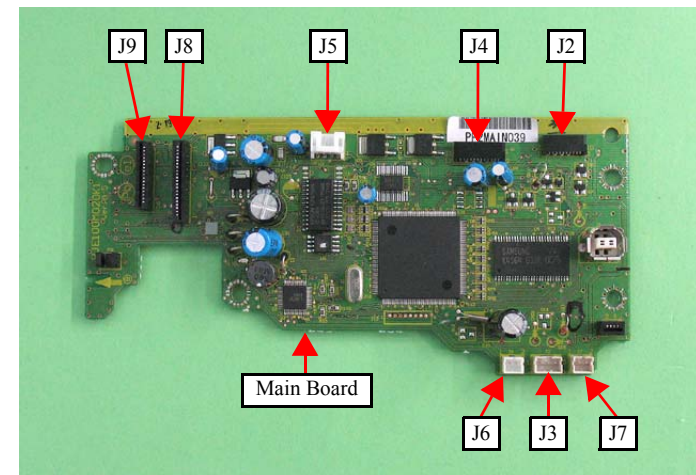


Figure 4-20. Removing the Main Board (1)

- Remove the four screws that secure the Main Board.
- Remove the Main Board and the Shield Plate with the PE Sensor Lever to the ASF side as shown below.

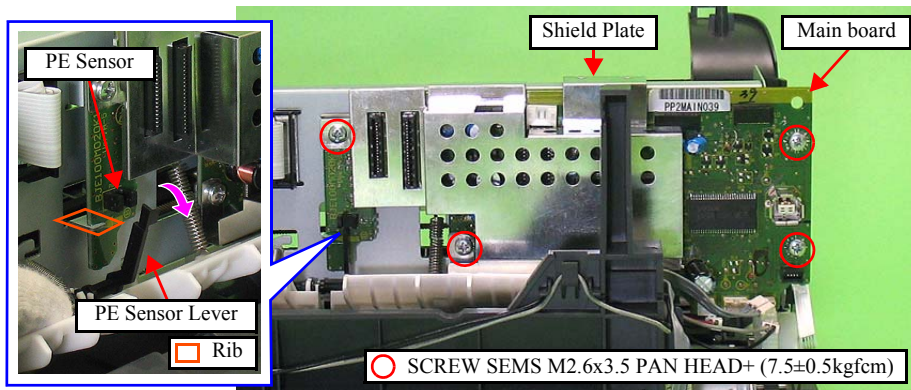


Figure 4-21. Removing the Main Board (2)



- When installing the Main Board, keep the PE Sensor Lever away (as shown in Fig.4-21) to avoid getting broken.
- Before tightening the screws, make sure to insert the Main Board to the rib of the Main Frame, and align the threaded hole of the Main Frame with the hole of the Main Board. (See Fig.4-21.)
- Tighten the screws in the order indicated in Fig.4-21.
- For the Shield Plate, hook its upper part to the Main Frame and secure them as shown below.

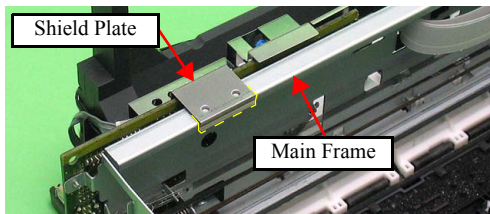


Figure 4-22. Installing the Main board



Whenever the Main Board Unit is removed/replaced, the required adjustments must be carried out.

- Chapter 5 “ADJUSTMENT” (p.100)

4.4.3 Power Supply Unit

- Parts/Components need to be removed in advance: Scanner Stand/Cover Wire (p60), Scanner Unit (p62), Middle Housing (p63) Panel Unit (p64)

- Removal procedure

- Disconnect the connector of the Power Supply Unit Cable (J3) from the Main Unit and release the Power Supply Unit cable from the ribs of the Lower Housing.
- Remove the screw that secures the Power Supply Unit.
- Remove the Power Supply Unit from the Lower Housing.

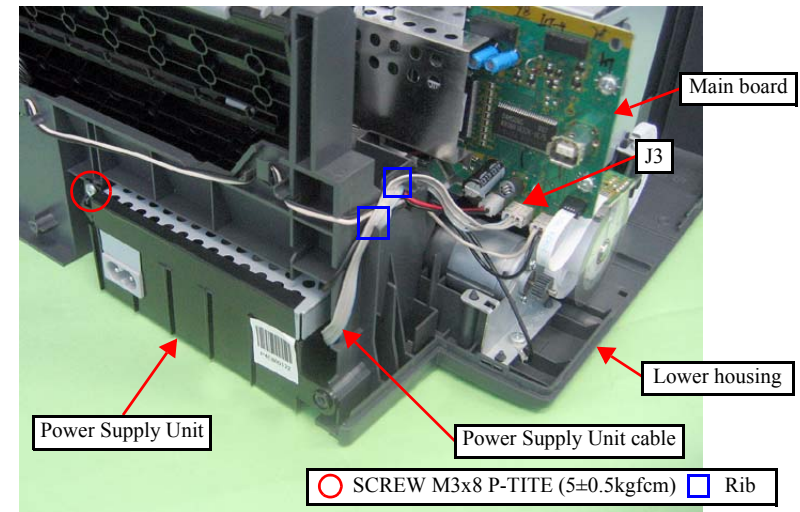


Figure 4-23. Removing the Power Supply Unit

4. Remove the screw that secures the Grounding Wire, and remove the Grounding Wire from the Power Supply Unit.

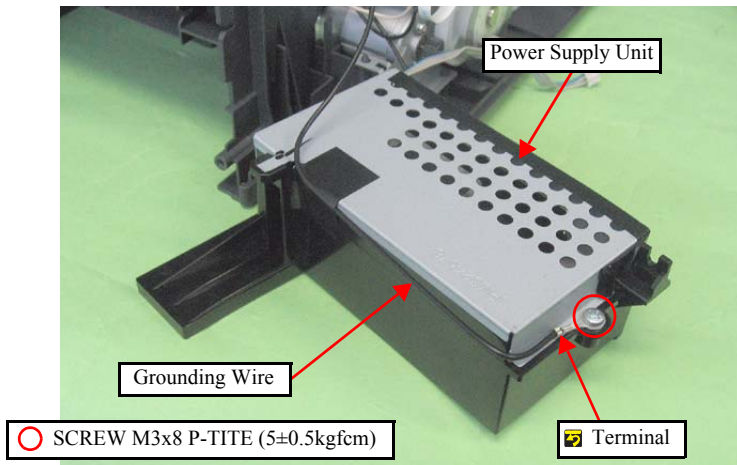


Figure 4-24. Removing the Power Supply Unit



- When installing the Grounding Wire, make sure that the terminal of the Grounding Wire gets contact with the plate of the Power Supply Unit as shown in Fig.4-24.
- Route the Power Supply Unit Cable through the two ribs of the Lower Housing. (See Fig.4-23.)



- When installing the Power Supply Unit, insert its protrusion to the hole of the Lower Housing, and align the rib and dowel of the Lower Housing with the positioning hole of the Power Supply Unit.

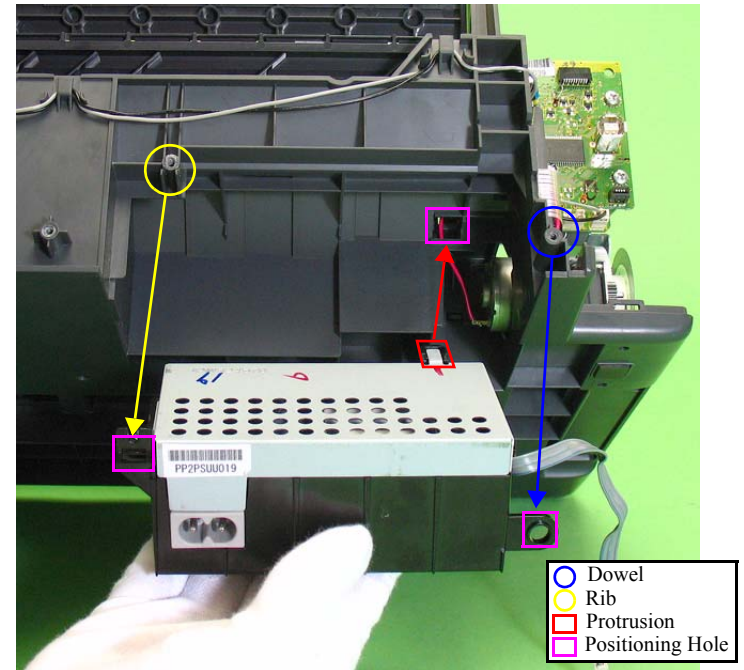


Figure 4-25. Installing the Power Supply Unit



Whenever the Power Supply Unit is removed/replaced, the required adjustments must be carried out.

- Chapter 5 “ADJUSTMENT” (p.100)

4.5 Disassembling the Printer Mechanism

4.5.1 Printhead

- Parts/Components need to be removed in advance:
Scanner Stand/Cover Wire (p60), Scanner Unit (p62), Middle Housing (p63)
Panel Unit (p64)
- Removal procedure
 1. Release the Carriage Lock and move the Carriage to the center.

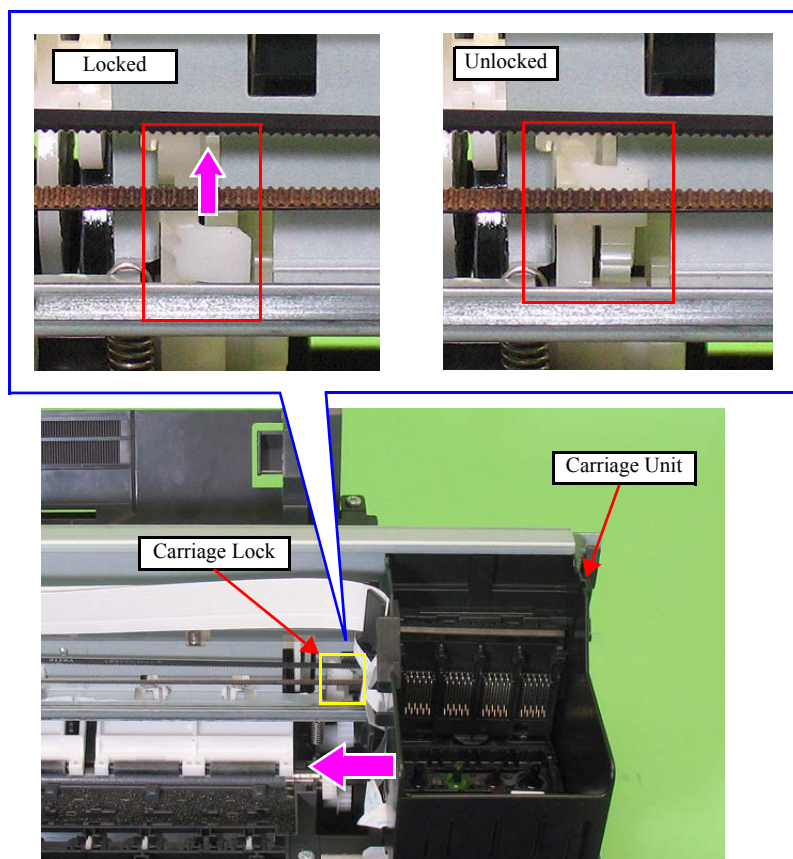


Figure 4-26. Removing the Printhead (1)

2. Release the FFC from the tabs of the Carriage.

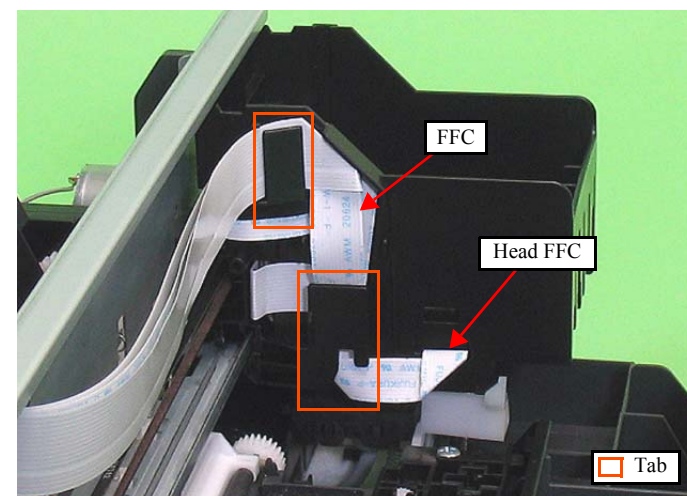


Figure 4-27. Removing the Printhead (2)

3. Pull out the FFC from the connector of the CR Contact Module (CN1).

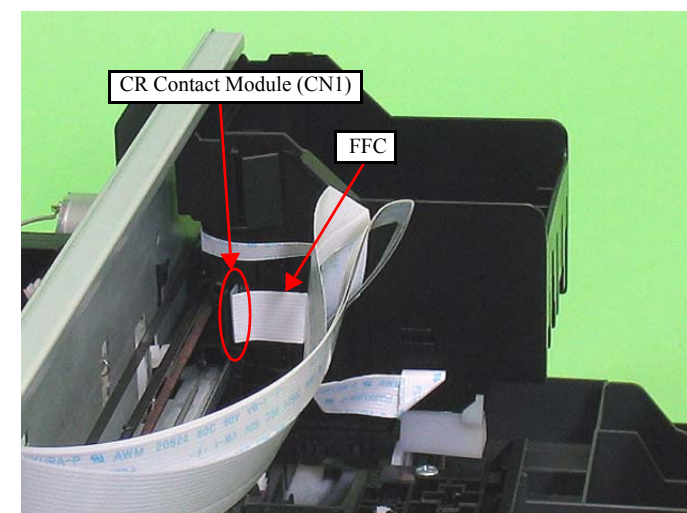


Figure 4-28. Removing the Printhead (3)

- Release the two hooks on both sides of the Carriage with a flathead precision screwdriver or a similar tool, and remove the Holder Contact Assy upward as shown below.

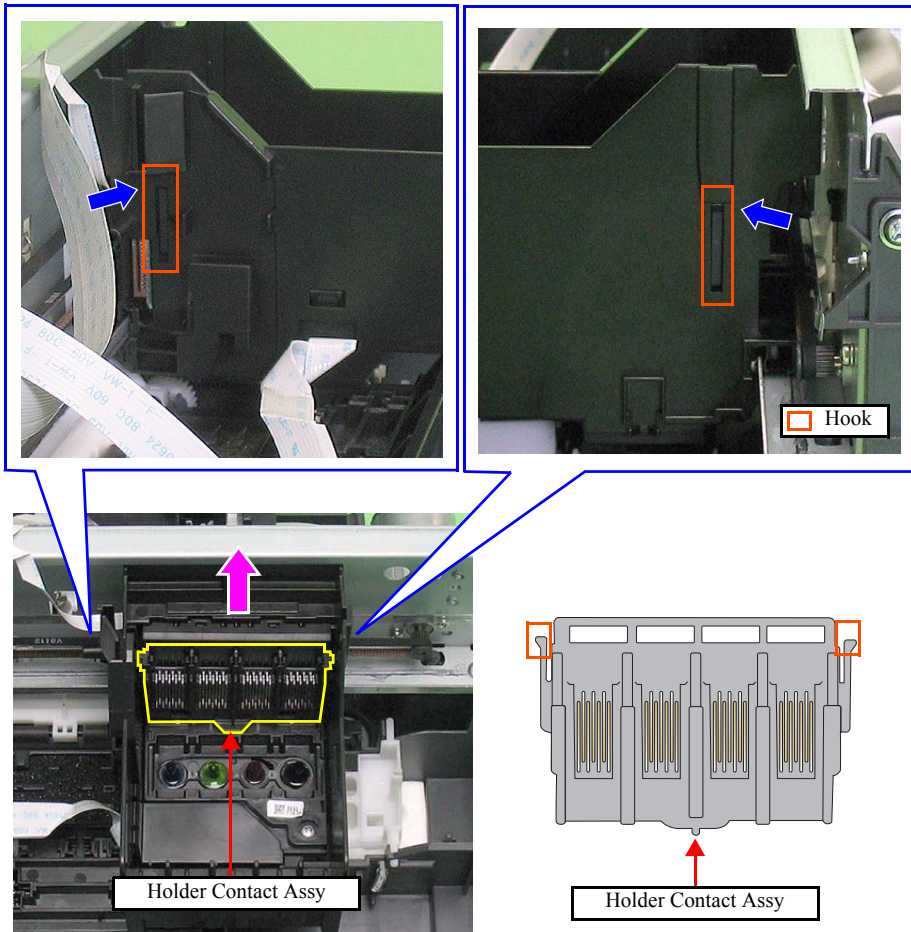


Figure 4-29. Removing the Printhead (4)

- Release the hook, and remove the FFC Cover.

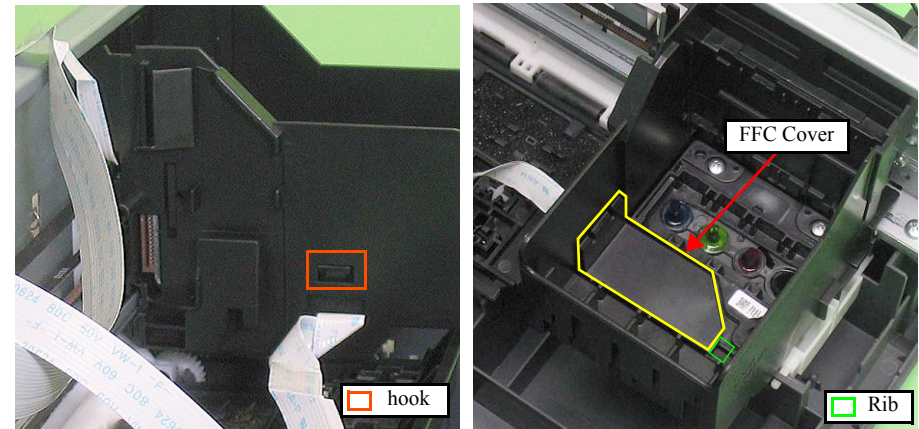


Figure 4-30. Removing the Printhead (5)



Be careful not to touch the nozzles with bare hands or damage the ink supply needles of the Printhead.

- Remove the three screws that secure the Printhead, and lift the Printhead with longnose pliers.

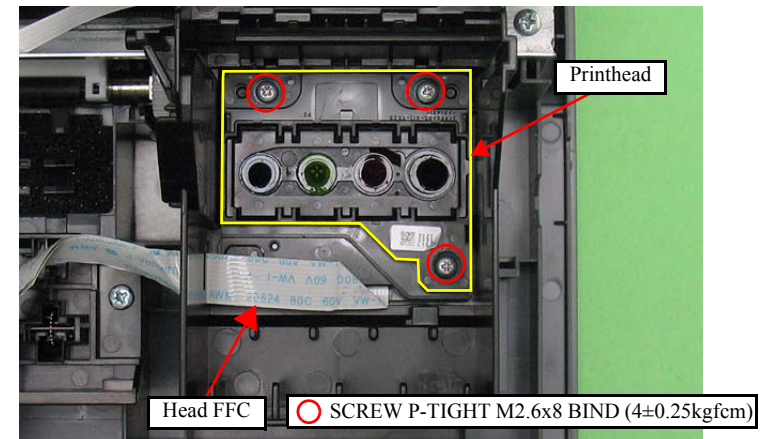


Figure 4-31. Removing the Printhead (6)

- Remove the Head FFC from the connector of the Printhead, and remove the Printhead.

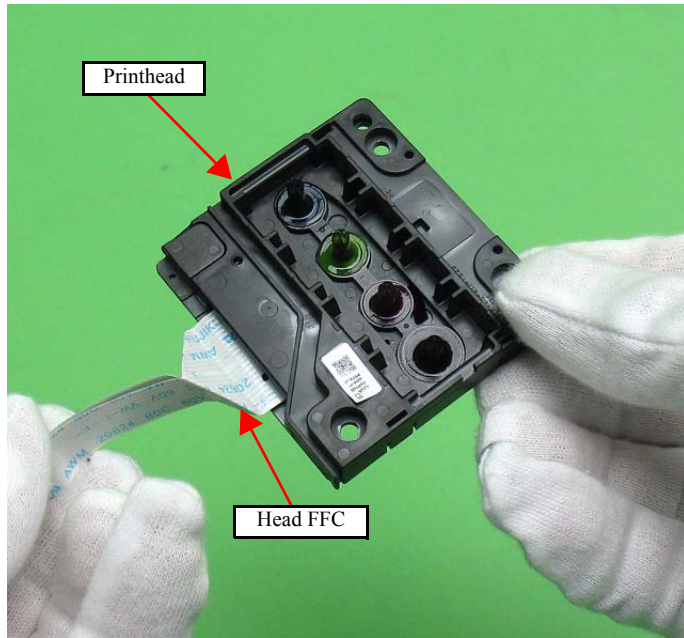


Figure 4-32. Removing the Printhead (7)



- When installing the FFC, route it through objects as shown in Fig.4-27 and Fig.4-31.
- When installing the FFC Cover, insert its rib to the hole of the CR Unit and secure it with the hook. (See Fig.4-30.)



- When installing the Contact Assys, secure them to the Holder Contact Assy with two each hooks on the Contact Assys.

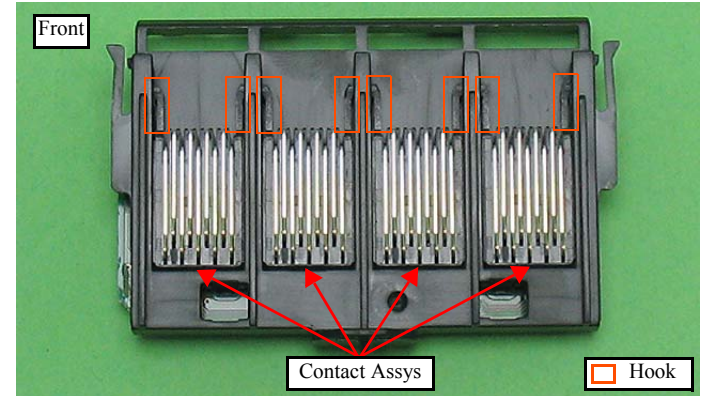


Figure 4-33. Assembling the Holder Contact Assy (1)

- When installing the CR Contact Module, secure it with four hooks of the Holder Contact Assy.

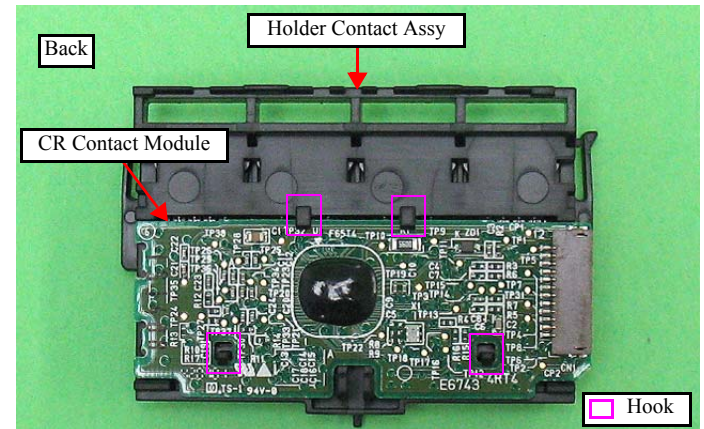


Figure 4-34. Assembling the Holder Contact Assy (2)



Whenever the Printhead is removed/replaced, the required adjustments must be carried out.

- Chapter 5 “ADJUSTMENT” (p.100)

4.5.2 CR Scale

- Parts/Components need to be removed in advance:
Scanner Stand/Cover Wire (p60), Scanner Unit (p62), Middle Housing (p63)
Panel Unit (p64)
- Removal procedure
 1. Release the Carriage Lock and move the Carriage to the center. (See "4.5.1 Printhead (p68)".)

CAUTION



- Do not touch the CR Scale with bare hands.
- Do not damage the CR Scale.
- Do not stretch the Extension Spring too much.

2. Remove the right side of the CR scale from the hook.
3. Pull out the CR Scale through the slit of the CR Encoder Sensor.

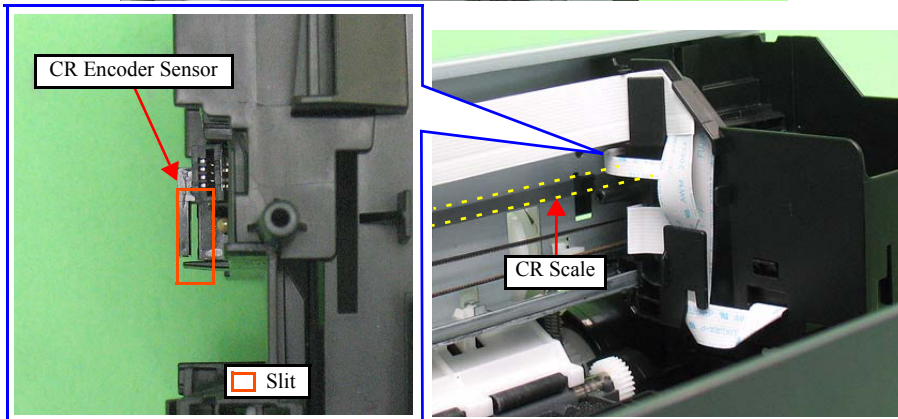
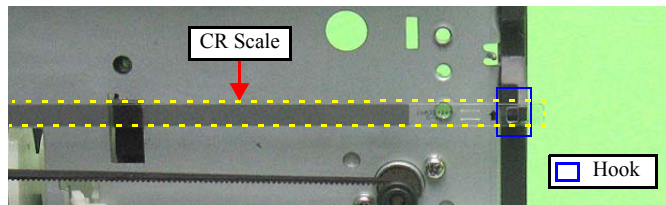


Figure 4-35. Removing the CR Scale (1)

4. Detach the Extension Spring from the Main Frame.
5. Remove the CR Scale from the rib of the Main Frame.

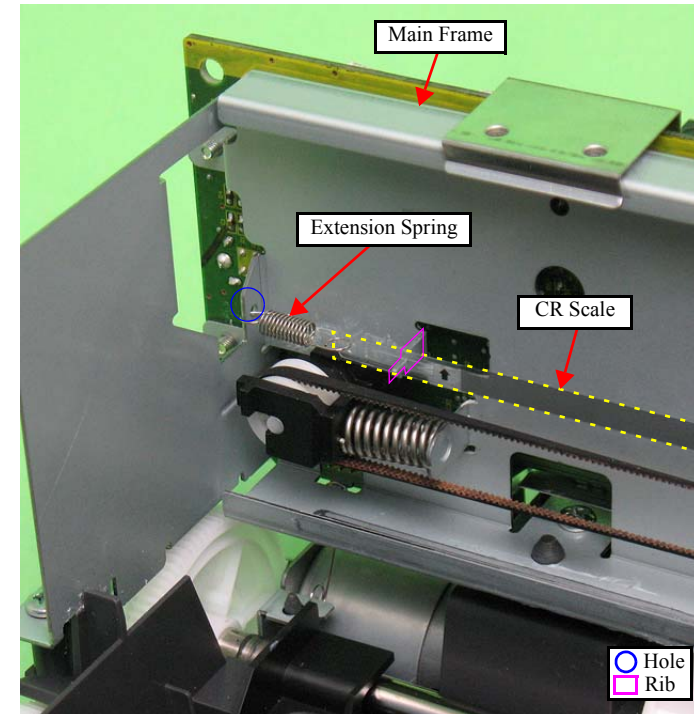


Figure 4-36. Removing the CR Scale (2)

REASSEMBLY



- When installing the CR scale, confirm that the arrows on both the edges of the CR scale face upward.
- Make sure to put the CR scale through the slit of the CR Encoder Sensor. (See Fig.4-35.)
- Make sure to confirm that the Extension Spring is not twisted, then install the eye of the spring to the hole of the Main Frame. (See Fig.4-36.)

ADJUSTMENT REQUIRED



Whenever the CR Scale removed/replaced, the required adjustments must be carried out.

- Chapter 5 "ADJUSTMENT" (p.100)

4.5.3 Hopper

- Parts/Components need to be removed in advance:
Scanner Stand/Cover Wire (p60), Scanner Unit (p62), Middle Housing (p63)
Panel Unit (p64)
- Removal procedure
 1. Release both the dowels that secure the Hopper, and remove the Hopper and the Compression Spring from the Lower Housing.

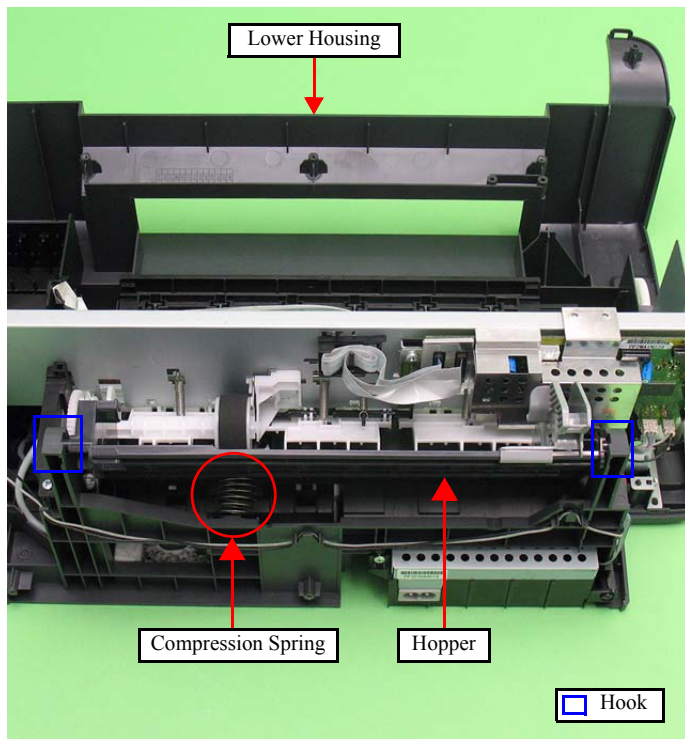


Figure 4-37. Removing the Hopper

2. Release the hook that secures the Edge Guide, and remove the Hopper from the Edge Guide.

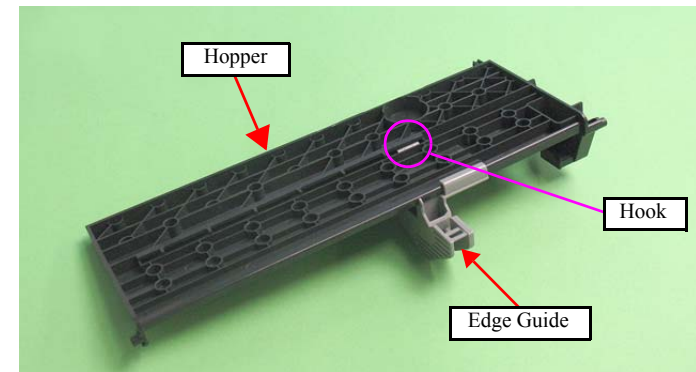


Figure 4-38. Removing the Edge Guide



When installing the Hopper, make sure to install the Compression Spring under the rib as shown below.

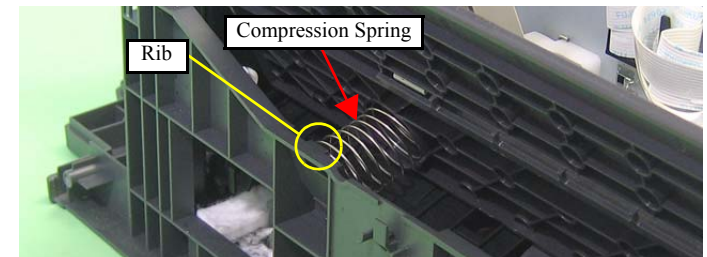


Figure 4-39. Assembling the Hopper



Whenever the Hopper is removed/replaced, the required adjustments must be carried out.

- Chapter 5 “ADJUSTMENT” (p.100)

4.5.4 PF Encoder/ PF Scale

- Parts/Components need to be removed in advance:
Scanner Stand/Cover Wire (p60), Scanner Unit (p62), Middle Housing (p63)
Panel Unit (p64)
- Removal procedure
 1. Disconnect the PF Encoder FFC from connector J11 on the Main Board.
 2. Remove the screw that secures the PF Encoder, and remove the PF Encoder.



- Do not touch the PF Scale with bare hands.
- Do not damage the PF Scale.

3. Peel off the PF Scale secured with the double-sided tape from the Spur Gear.

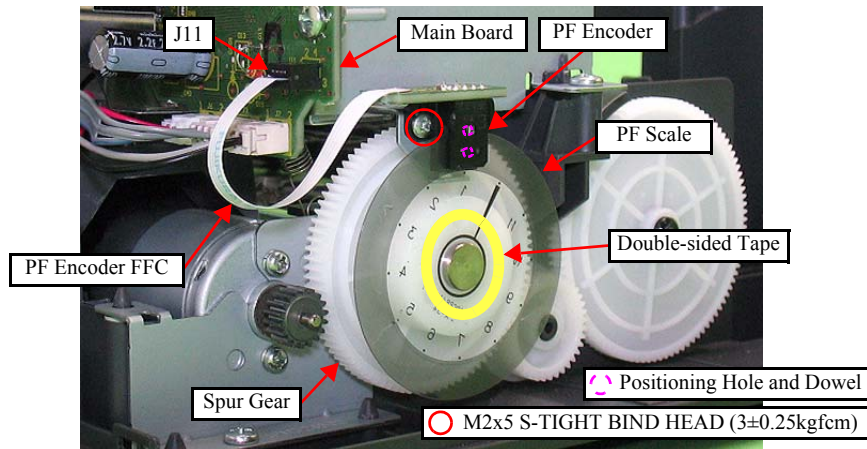


Figure 4-40. Removing the PF Encoder/ PF Scale



- When installing the PF Encoder, be sure to align the dowels in the rear side of the PF Encoder with the positioning holes of the PF Motor. (See Fig.4-40.)
- When installing the PF Encoder, be sure to put the PF Scale through the slit of the PF Encoder.



- Whenever the PF Encoder/ PF Scale removed/replaced, the required adjustments must be carried out.
- Chapter 5 “ADJUSTMENT” (p.100)

4.5.5 EJ Roller/ EJ Frame Assy

- Parts/Components need to be removed in advance:
Scanner Stand/Cover Wire (p60), Scanner Unit (p62), Middle Housing (p63)
Panel Unit (p64)
- Removal procedure
 1. Remove the two screws that secure the EJ Frame Assy, and remove the EJ Frame Assy from the Lower Housing.

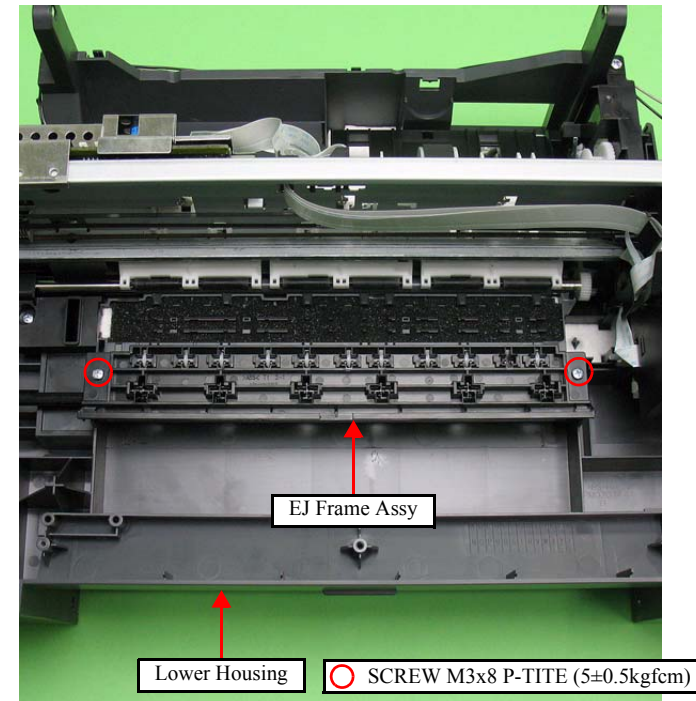


Figure 4-41. Removing the EJ Frame Assy

- Insert a flathead precision screwdriver between the EJ Roller Gear and the rib of the EJ Roller, and remove the EJ Roller Gear by pushing it in the direction of the arrow.

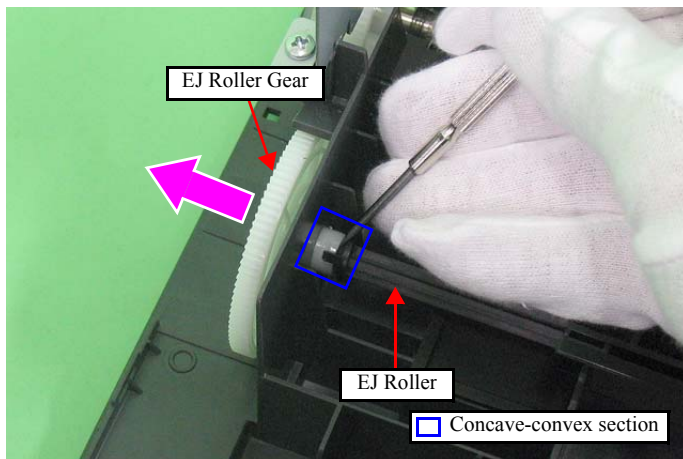


Figure 4-42. Removing the EJ Roller (1)

CAUTION



Be careful not to touch the rubber part of the EJ Roller to avoid degrading the print quality.

- Remove the EJ Roller by pushing the bearing on the right side of the Lower Housing in the direction of the arrow.

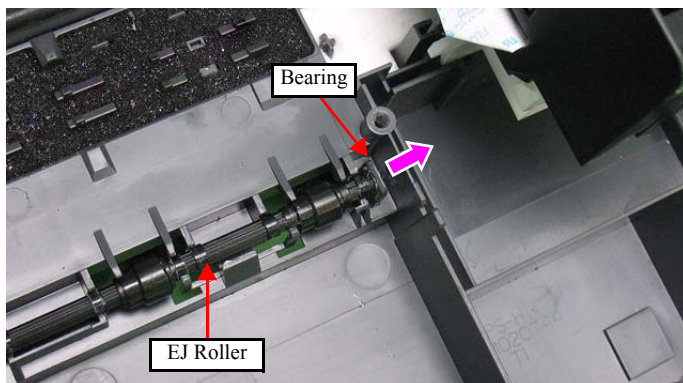


Figure 4-43. Removing the EJ Roller (2)

REASSEMBLY



- When installing the EJ Roller Gear, be sure to align the concave section of the EJ Roller Gear with the convex section of the EJ Roller, then secure them. (See Fig.4-42.)
- When replacing the Wheel Star Metal, Spring Star Wheel, and Wheel Star EXIT, install them in the direction as shown below, and secure them with the hooks of EJ Frame Assy.

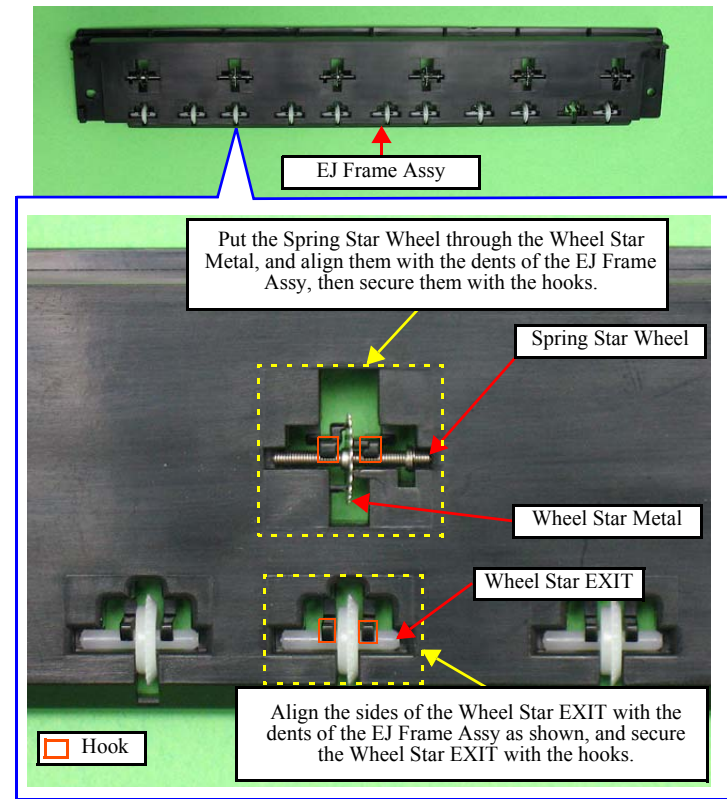


Figure 4-44. Assembling the EJ Frame Assy

**ADJUSTMENT
REQUIRED**



- Whenever the EJ Roller is removed/replaced, the required adjustments must be carried out.
 - Chapter 5 “ADJUSTMENT” (p.100)
- After replacing the EJ roller, be sure to perform the required lubrication.
 - Chapter 6 “MAINTENANCE” (p.108)

4.5.6 CR Motor/ Driven Pulley

- Parts/Components need to be removed in advance:
Scanner Stand/Cover Wire (p60), Scanner Unit (p62), Middle Housing (p63)
Panel Unit (p64)
- Removal procedure

CAUTION



- Be careful not to break the soldered portion of the CR Motor.
- When removing the CR Motor and Driven Pulley, make sure to hold the Timing Belt somehow so as not to allow the grease of Main Frame to come in contact with the Timing Belt. It may damage the Timing Belt.
- Be careful not to lose the Compression Spring when removing the Driven Pulley Holder.
- Do not damage the Pinion Gear of the CR Motor.
- Be careful not to contaminate the CR scale with grease.

1. Disconnect the CR Motor Cable from connector J7 on the Main Board, and release it from the Lower Housing.

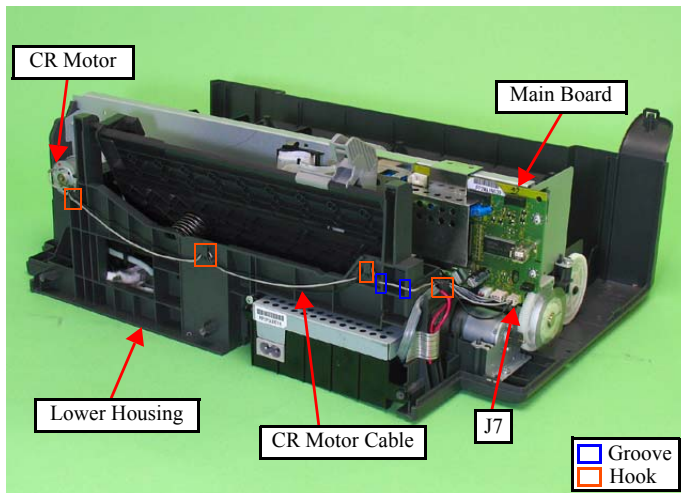


Figure 4-45. Removing the CR Motor (1)

2. Release the Carriage Lock, and move the CR Unit to the center. (See "4.5.1 Printhead (p68)".)
3. Loosen the tension of the Timing Belt by pressing the Driven Pulley Holder in the direction of the arrow, and remove the Timing Belt from the Pinion Gear of the CR Motor.
4. Remove the Driven Pulley Holder and Compression Spring from the Main Frame.
5. Remove the two screws that secure the CR Motor, and remove the CR Motor from the Main Frame.

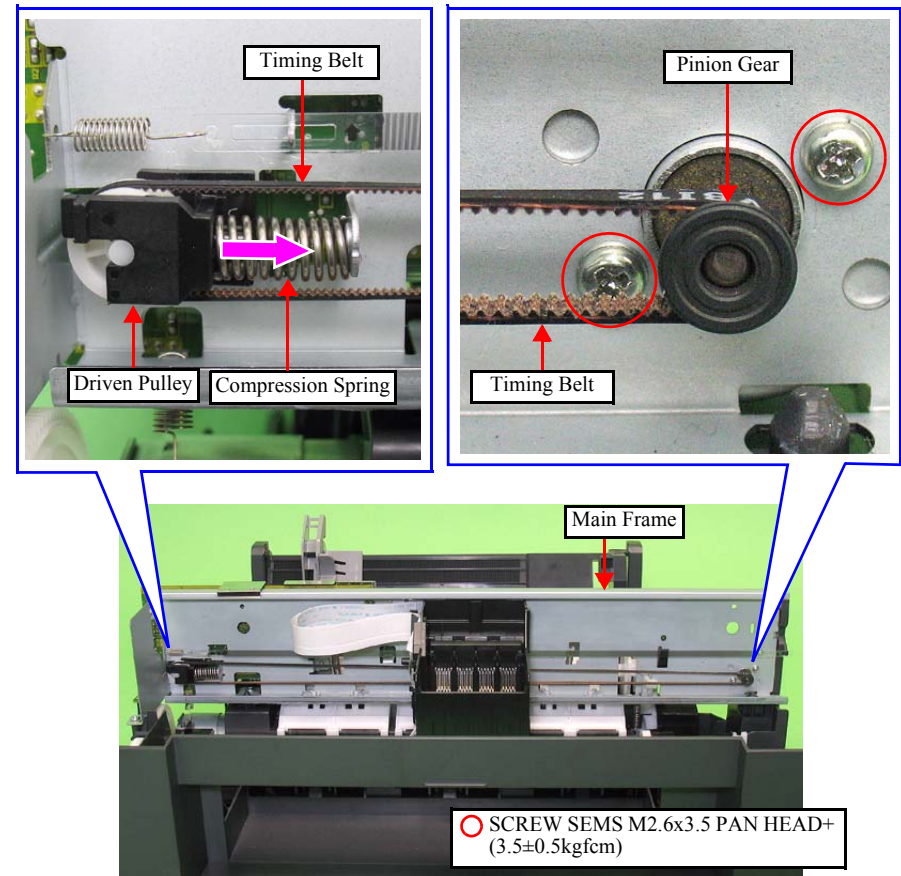


Figure 4-46. Removing the CR Motor (2)

REASSEMBLY



- Route the CR Motor cable through the four hooks and the two grooves of the Lower Housing with some slack to prevent breaking the soldered portions. (See Fig.4-45.)
- Be sure to install the CR Motor with the groove facing upward.

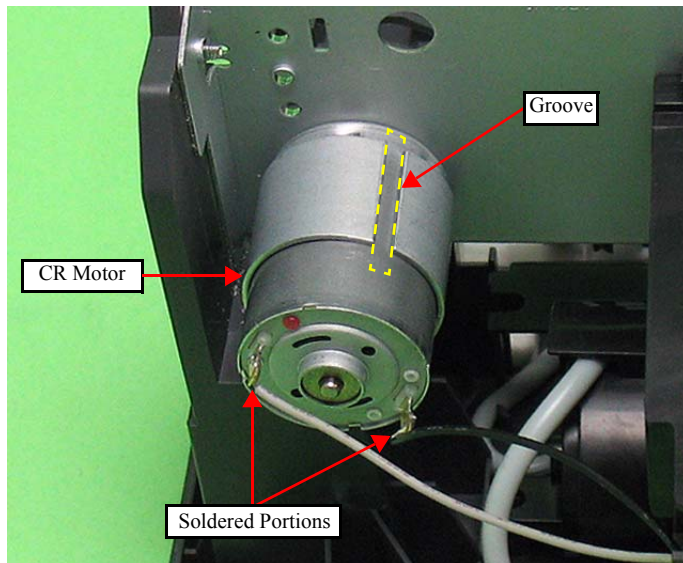


Figure 4-47. Installing the CR Motor

REASSEMBLY



When installing the Timing Belt to the Pinion Gear of the CR Motor follow the procedure below taking care not to twist the Timing Belt.

1. Align the hooks of the Driven Pulley with the hole of the Main Frame, and install the Driven Pulley to the Main Frame.
2. Attach the Timing Belt to the Driven Pulley with toothed side facing inward. (See Fig.4-46.)
3. Install the Compression Spring between the protrusion of the Driven Pulley and that of the Main Frame. (See Fig.4-46.)
4. Slide the Driven Pulley to the CR Motor (in the direction of the arrow) taking care not to let the Timing Belt come off, and install the Timing Belt to the Pinion Gear of the CR Motor. (See Fig.4-46.)

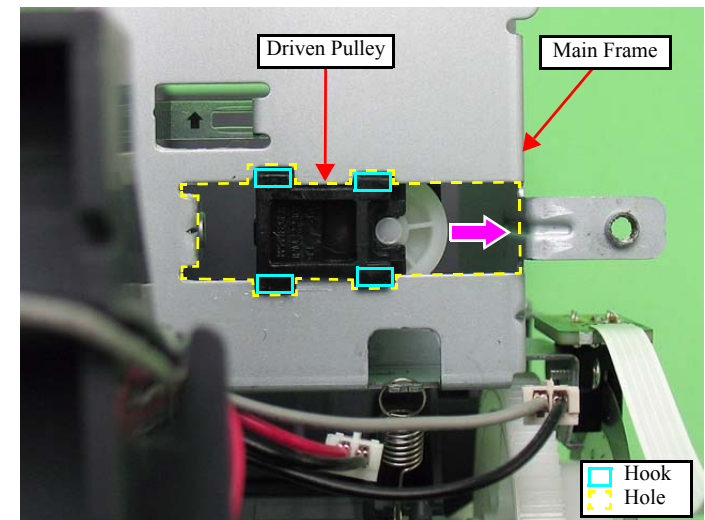


Figure 4-48. Installing the Driven Pulley

ADJUSTMENT
REQUIRED

- Whenever the CR Motor is removed/replaced, the required adjustments must be carried out.
 - Chapter 5 “ADJUSTMENT” (p.100)
- After replacing the Driven Pulley, be sure to perform the required lubrication.
 - Chapter 6 “MAINTENANCE” (p.108)

4.5.7 Ink System

- Parts/Components need to be removed in advance:
Scanner Stand/Cover Wire (p60), Scanner Unit (p62), Middle Housing (p63)
Panel Unit (p64), CR Motor/ Driven Pulley (p75)
- Removal procedure

CAUTION



- Be careful not to contaminate the surroundings with ink.
- Do not bend the Spring Cleaner Lever and the Cleaner Case Spring.
- Do not touch the Sealing Rubber, the Blade Wiper or the Felt Wiper with bare hands or damage them.

- Cap Assy
 1. Remove the Cleaner Lever Spring.
 2. Remove the Cleaner Case Spring.

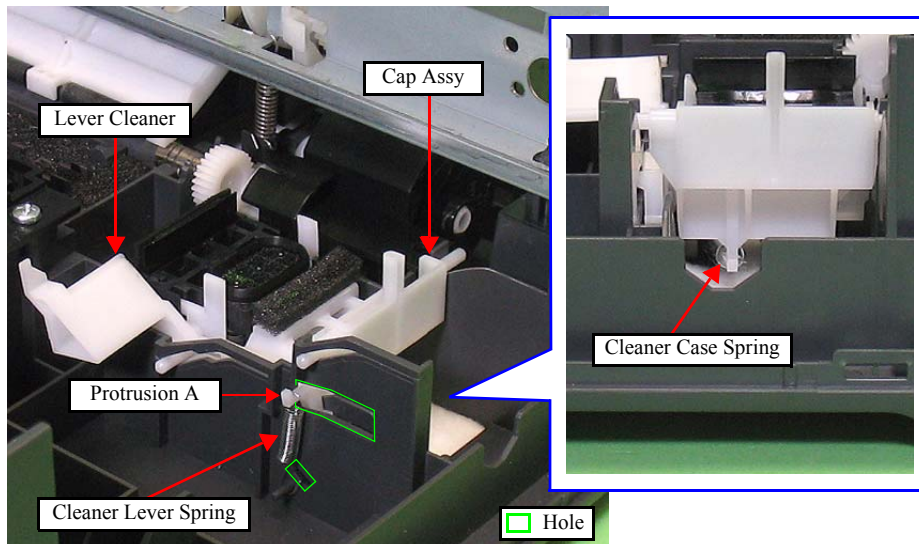


Figure 4-49. Removing the Cap Assy (1)

3. Insert a flathead precision screwdriver between the Lower Housing and the Pump Assy and push it in the direction of the arrow to release the hook.

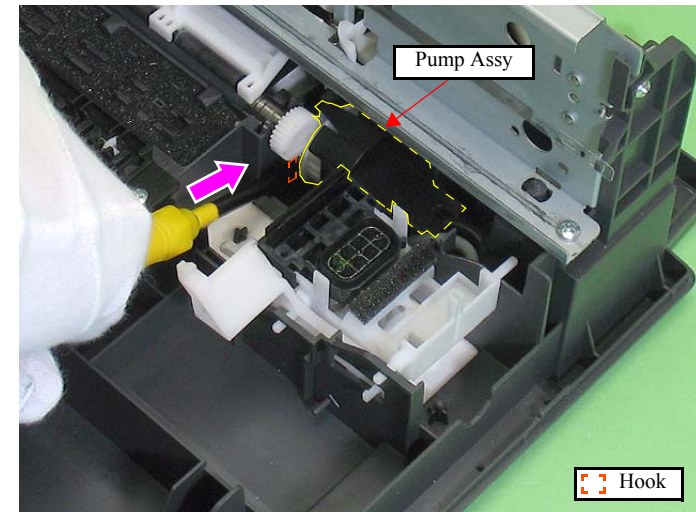


Figure 4-50. Removing the Cap Assy (2)

4. Move the Pump Assy to the ASF slightly, and remove the protrusion B of the Cap Assy.
5. Remove the two protrusion Cs of the Pump Assy from the Lower Housing.

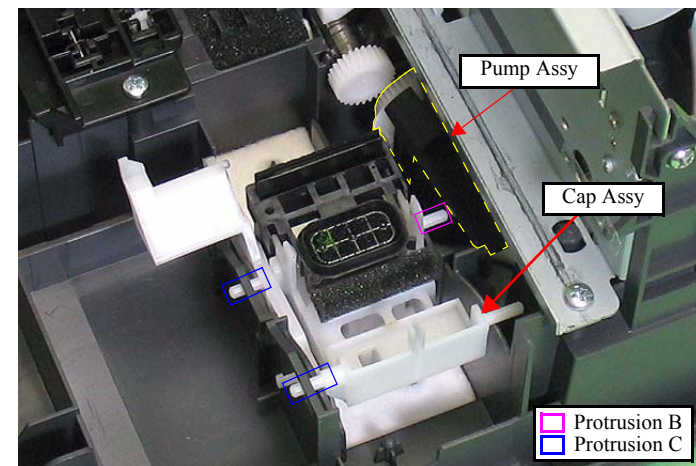


Figure 4-51. Removing the Cap Assy (3)

- Pull out the Waste Ink Tube through the rear of the Cap Assy, and remove the Cap Assy.

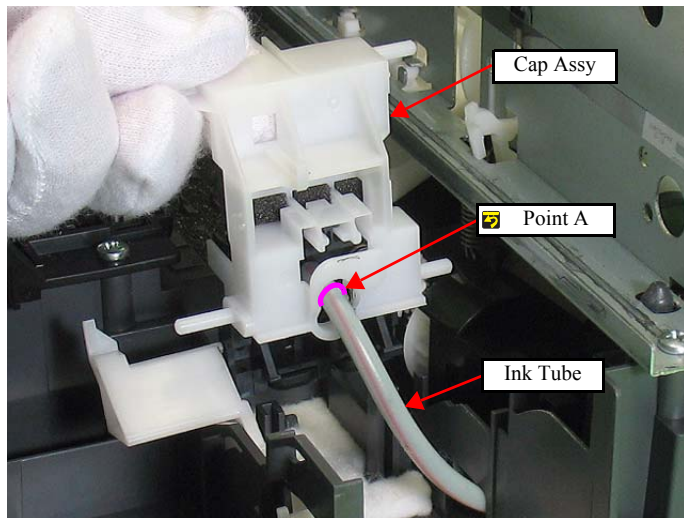


Figure 4-52. Removing the Cap Assy (4)

■ Pump Assy

- Pull out the Waste Ink Tube together with the Holder Tube through the Waste Ink Cover.
- Release the Waste Ink Tube from the hook of the ASF Unit.

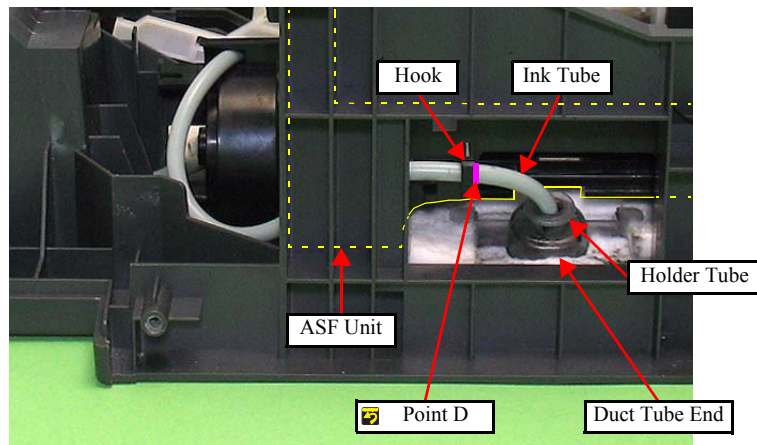


Figure 4-53. Removing the Pump Assy (1)

- Release the two hooks, and remove the Pump Assy from the Lower Housing.

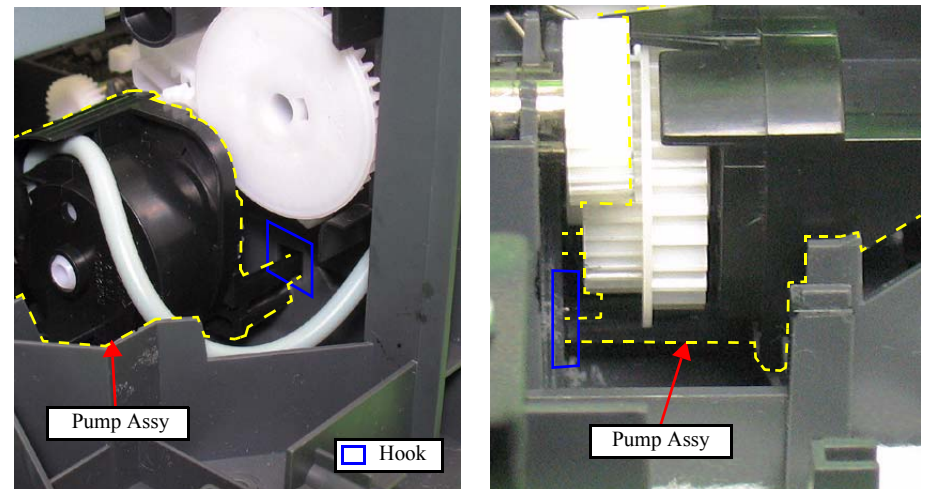


Figure 4-54. Removing the Pump Assy (2)



- When installing the Cleaner Lever Spring, insert the longer end of the spring into the Lower Housing, and secure it to the protrusion A of the Cleaner Lever attached through the hole of the Lower Housing. (See Fig.4-49.)

REASSEMBLY



- When routing the Ink Tube, confirm the following.
 - Insert point A of the tube carefully into the Cap Assy not to let it pressed. (See Fig.4-52, Fig.4-63)
 - Align point D with the right edge of the hook on the ASF Unit, then secure it. (See Fig.4-53, Fig.4-63)
 - Insert the Holder Tube up to point E as shown below, and insert the holder into the Duct Tube End. (See Fig.4-53, Fig.4-63)

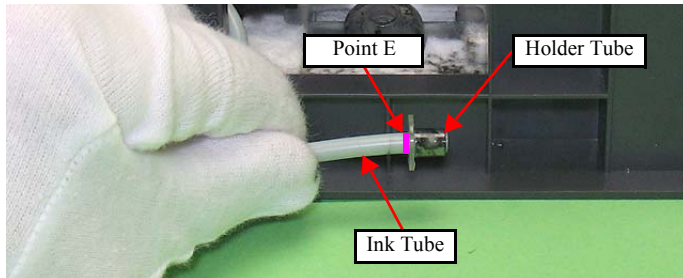


Figure 4-55. Installing the Pump Assy (1)

- Route the Waste Ink Tube through the ribs of the Lower Housing as shown below.

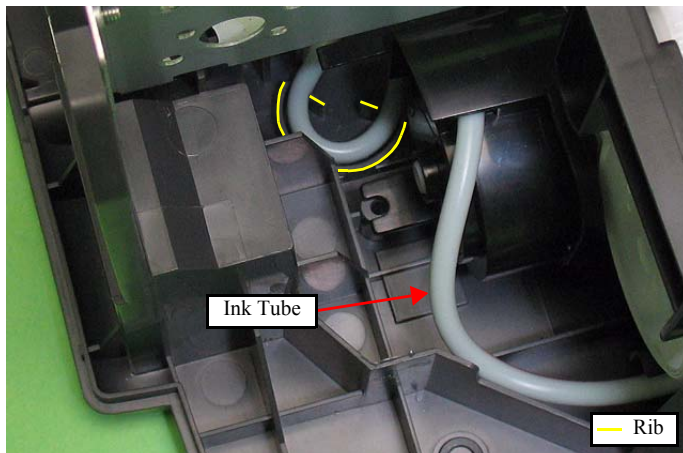


Figure 4-56. Installing the Pump Assy (2)

ADJUSTMENT
REQUIRED

Whenever the Ink System removed/replaced, the required adjustments must be carried out.

- Chapter 5 “ADJUSTMENT” (p.100)

DISASSEMBLING THE CAP ASSY

- Disassembly Procedure

CAUTION



Do not contaminate or damage the Sealing Rubber, Blade Wiper, and Felt Wiper.

- Remove the Foam Cap Side from the Case Cleaner.
- Release the two hooks of the IS Cap Assy, and remove the Blade Wiper and Felt Wiper.

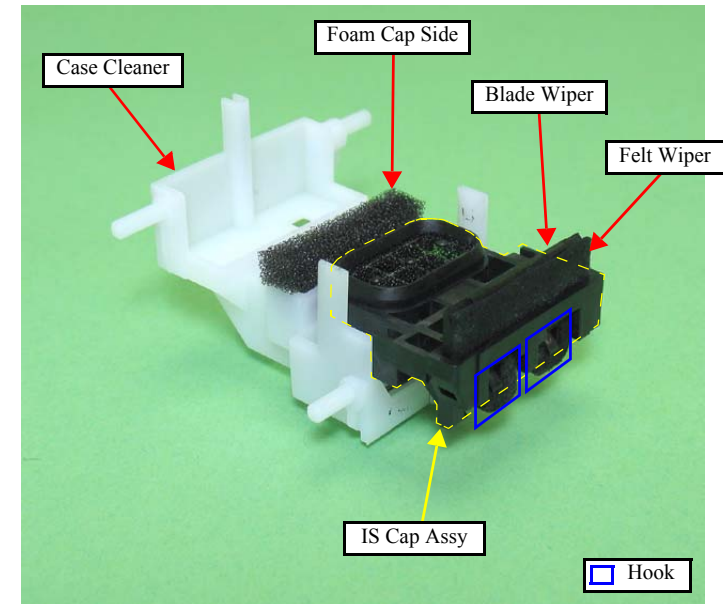


Figure 4-57. Disassembling the Cap Assy (1)

3. Release the two hooks of the IS Cap Assy by rotating it to the direction of arrow pulling out the central rib of the assy., and remove the IS Cap Assy from the Case Cleaner.

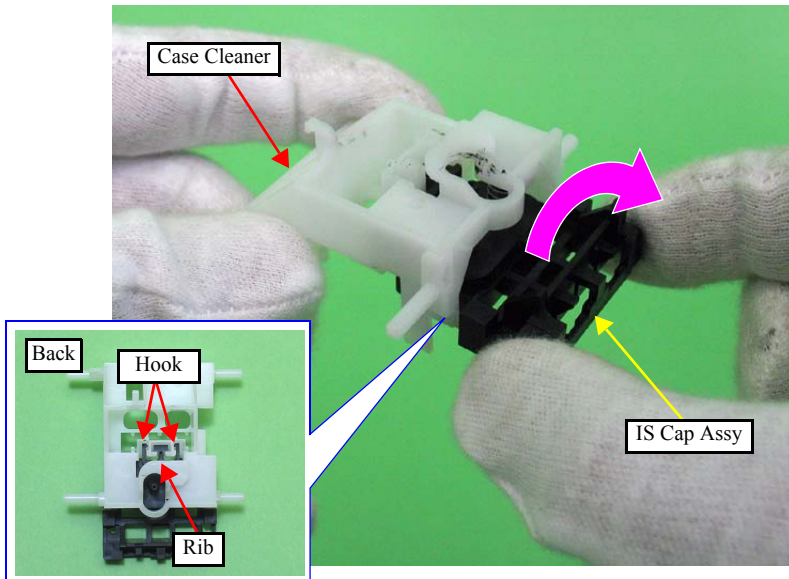


Figure 4-58. Disassembling the Cap Assy (2)

4. Remove the Cleaner Cap Spring from the dowels of the IS Cap Assy.

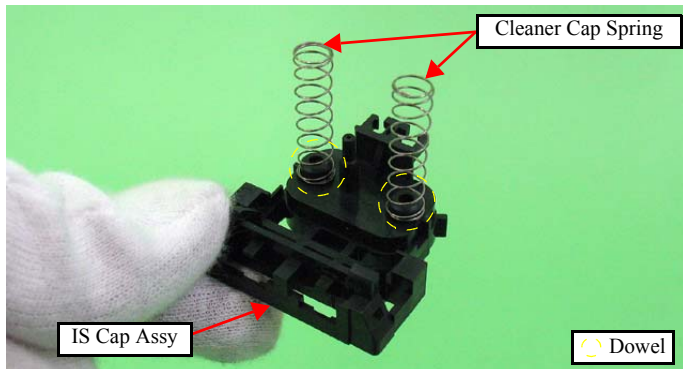


Figure 4-59. Disassembling the Cap Assy (3)



- When installing the Foam Cap Side, align the notches of the Foam Cap Side with the ribs of the Case Cleaner, and insert them without any gap. (See Fig.4-60.)
- When installing the IS Cap Assy, install the Cleaner Cap Spring to the dowels of the Case Cleaner.

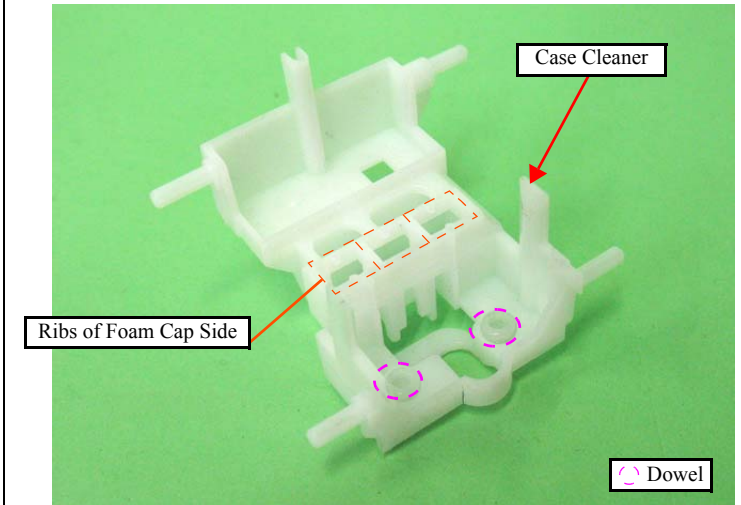


Figure 4-60. Assembling the Cap Assy (1)

- When installing the Blade Wiper and the Felt Wiper, align the dowels of the Blade Wiper with the positioning holes of the Felt Wiper.

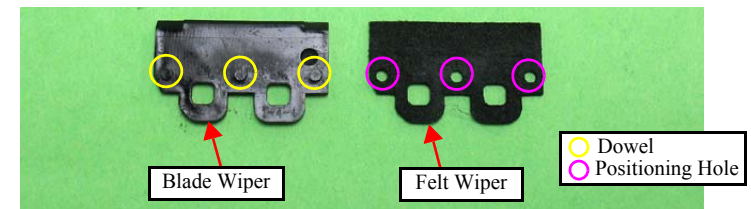


Figure 4-61. Assembling the Cap Assy (2)

DISASSEMBLING THE PUMP ASSY

□ Disassembly Procedure

1. Release the hook of the Pump Housing and remove the Gear Pump Idle.
2. Remove the Gear Pump and Bracket Pump from the Pump Housing.
3. Remove the Roller Pump from the Bracket Pump.
4. Remove the Waste Ink Tube from the Pump Housing.

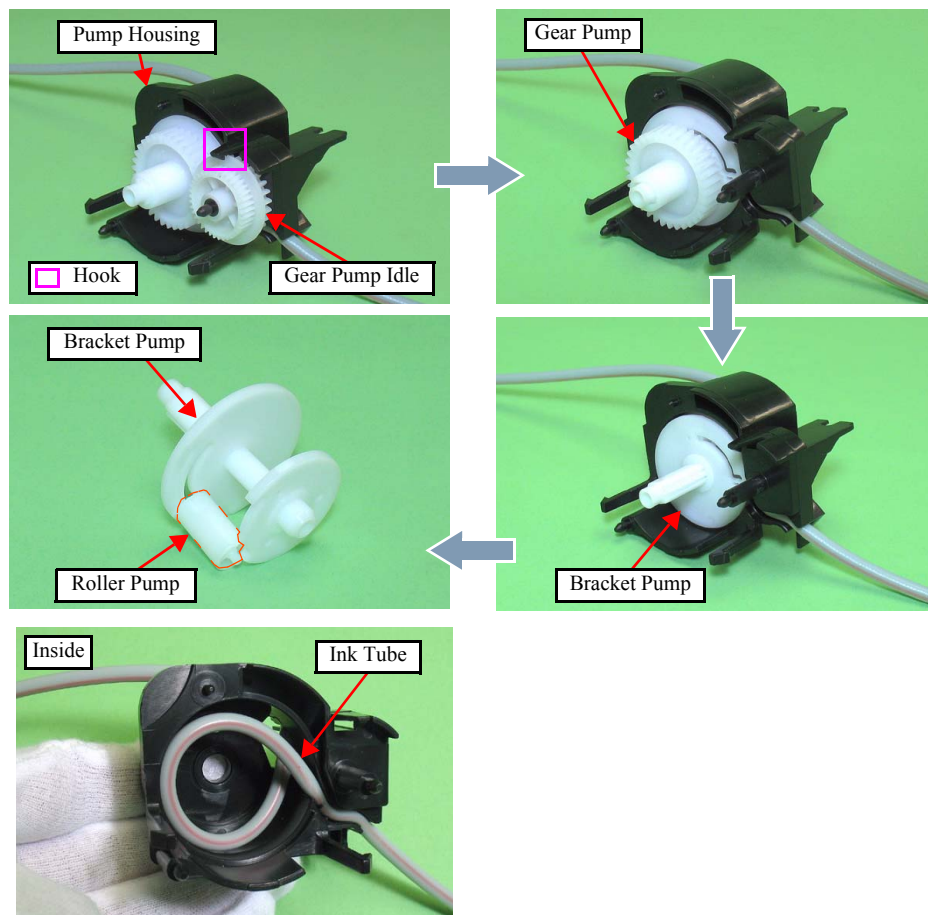


Figure 4-62. Disassembling the Pump Assy



When assembling the Pump Assy, follow the instructions below.

1. Mark five points on the Ink Tube as shown below.

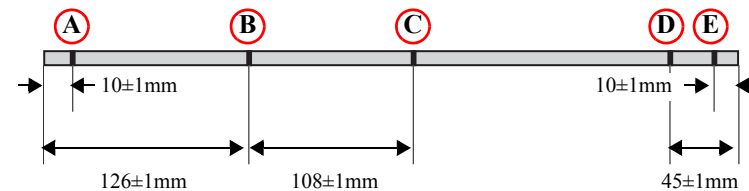


Figure 4-63. Marking on the Ink Tube

2. Secure point B of the tube to the Pump Housing as shown below.

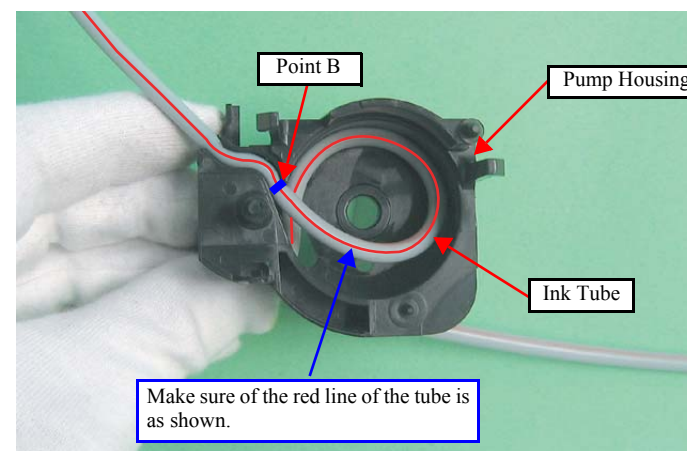


Figure 4-64. Assembling the Pump Assy (1)

REASSEMBLY



3. Secure point C of the tube to the Pump Housing as shown below.

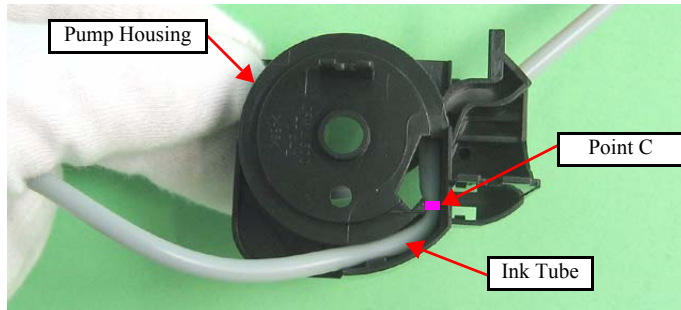


Figure 4-65. Assembling the Pump Assy (2)

4. Install the Roller Pump to the Bracket Pump. (See Fig.4-62.)
 5. Set the tube inside the Bracket Pump, and install the Bracket Pump to the Pump Housing.
 6. Rotate the Bracket Pump shaft and make sure that the Roller Pump shaft moves to both ends in the Groove.

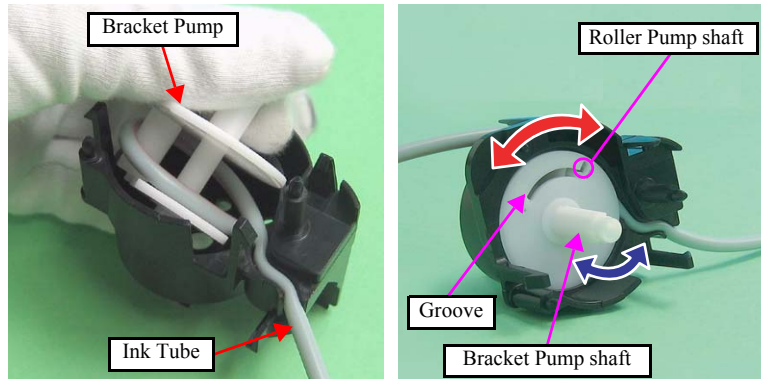


Figure 4-66. Assembling the Pump Assy (3)

7. Make sure that point C is placed in the correct position. (See Fig.4-65.)
 8. Install the Gear Pump. (See Fig.4-62.)
 9. Install the Gear Pump Idle. (See Fig.4-62.)

4.5.8 PF Motor

- Parts/Components need to be removed in advance:
 Scanner Stand/ Cover Wire (p60), Scanner Unit (p62), Middle Housing (p63)
 Panel Unit (p64), Hopper (p72), Main Board (p65)
- Removal procedure
 1. Pull out the PF Motor cable and the Ferrite Core from the hole of the Lower Housing to release them.

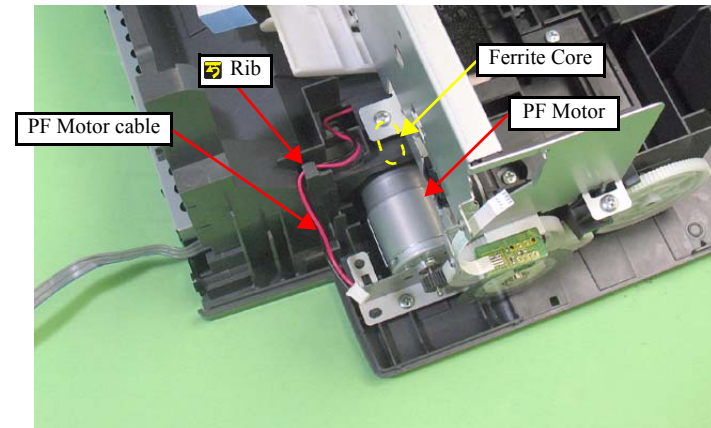


Figure 4-67. Removing the PF Motor (1)

2. Remove the Grounding Spring from the hook of the Main Frame and the Bracket.

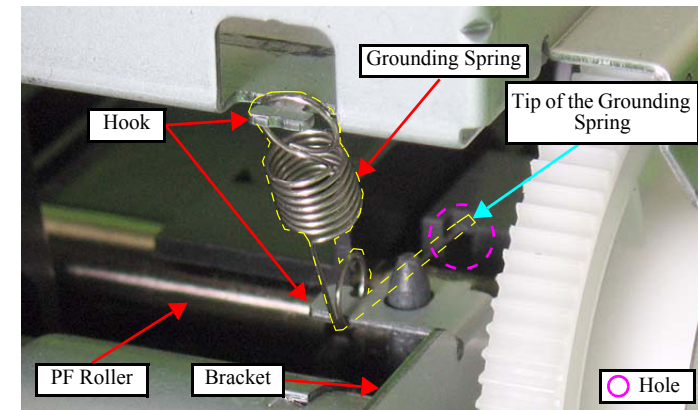


Figure 4-68. Removing the PF Motor (2)

CAUTION

- Do not damage the PF Roller Gear.
- Do not damage the Pinion Gear.
- Be careful of not to break the soldered portions.

3. Remove the screw that secures the Bracket.
4. Release the Bracket from the dowels of the Lower Housing, and remove the Bracket and the PF Motor while pulling out the PF Motor Cable (see Fig.4-67.) through the hole of the Lower Housing.

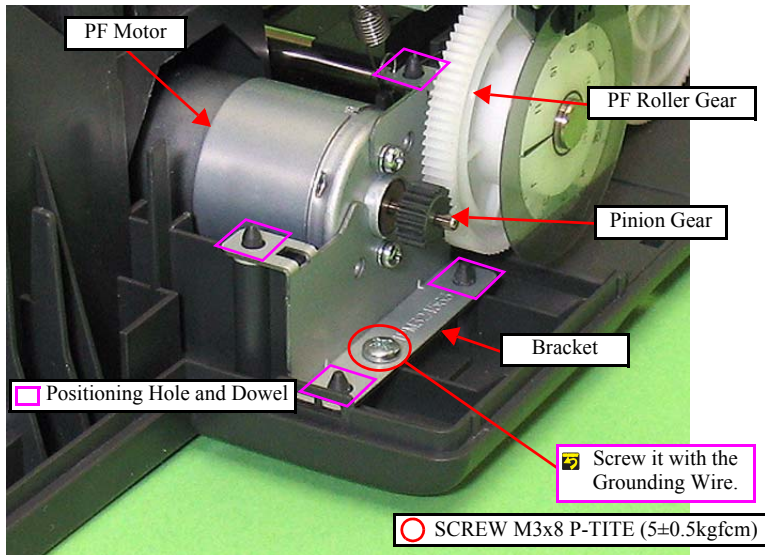


Figure 4-69. Removing the PF Motor (3)

5. Remove both the screws that secure the PF Motor.
6. Remove the PF Motor pulling out the shaft of the motor through the notch of the Bracket.

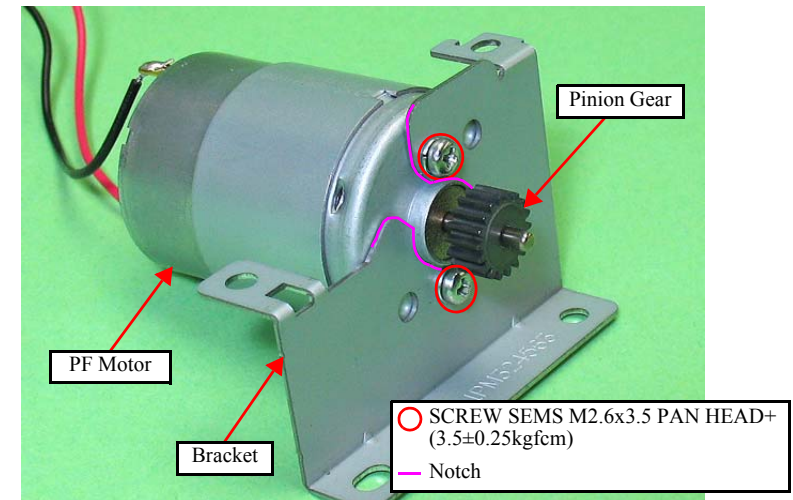


Figure 4-70. Removing the PF Motor (4)

REASSEMBLY

- When installing the PF Motor, insert the black cable over the red one. (See Fig.4-70.)
- Install the Grounding Spring as follows: (See Fig.4-68.)
 1. Insert the tip of the spring to the hole of the Lower Housing.
 2. Attach the eyes of the spring to the hook of the Main Frame and that of the Bracket to secure it.
- Before securing the Bracket, align the four positioning holes of it with the four dowels of the Lower Housing. (See Fig.4-69.)
- Don not damage the PF Roller Gear and the Pinion Gear.
- Route the PF Motor Cable following the procedure below. (See Fig.4-67.)
 1. When pulling out the cable from the hole of the Lower Housing, give the cable some slack to prevent breaking the soldered portions.
 2. Route the cable through the rib.

**ADJUSTMENT
REQUIRED**

Whenever the PF Motor removed/replaced, the required adjustments must be carried out.

- Chapter 5 “ADJUSTMENT” (p.100)

4.5.9 Main Frame

- Parts/Components need to be removed in advance:
Scanner Stand/ Cover Wire (p60), Scanner Unit (p62), Middle Housing (p63)
Panel Unit (p64), Hopper (p72), Main Board (p65)
CR Motor/ Driven Pulley (p75), Ink System (p77), PF Encoder/ PF Scale (p73)
- Removal procedure

CAUTION



- Be cautious not to touch the LD Roller and the roller part of the Upper Paper Guide with bare hands to avoid degrading the print quality.
- Be careful not to deform the Extension Spring when removing it.

1. Remove the Grounding Spring. (See "4.5.8 PF Motor (p82)".)
2. Remove the five Extension Springs.

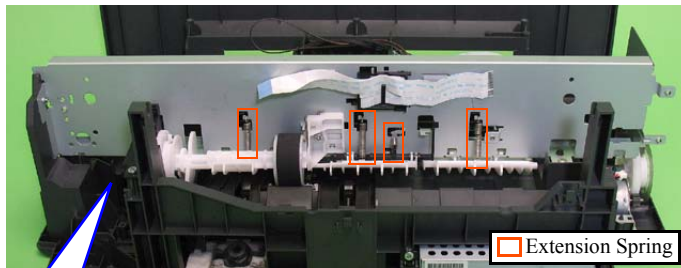


Figure 4-71. Removing the Main Frame (1)

3. Remove the screw that secures the Bracket.

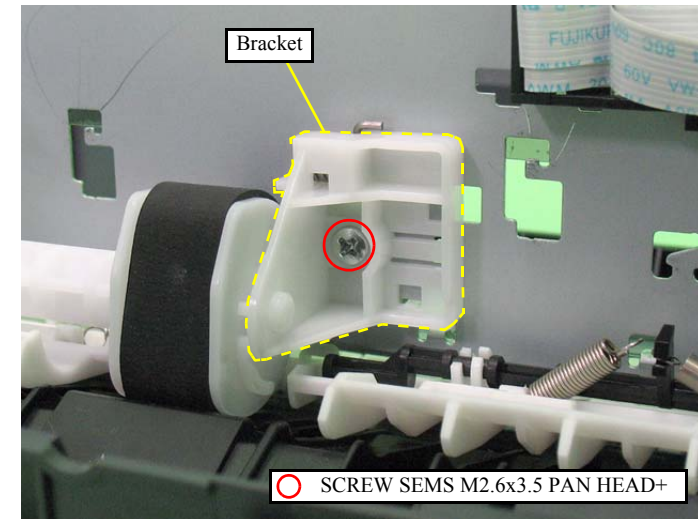


Figure 4-72. Removing the Main Frame (2)

4. From the front of the Main Frame, release the central hook in the Bracket with the flathead precision screwdriver.
5. Move the Bracket in the direction of the arrow to release the upper hook and the lower one of the Bracket from the hole of the Main Frame, then remove the Bracket.

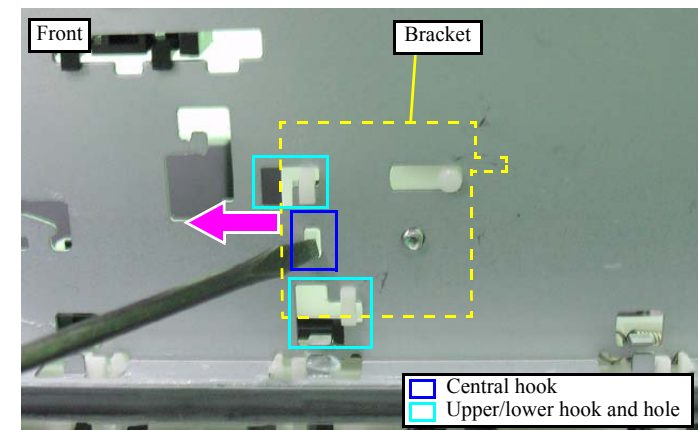


Figure 4-73. Removing the Main Frame (3)

6. Remove the four screws that secure the Main Frame to the Lower Housing.

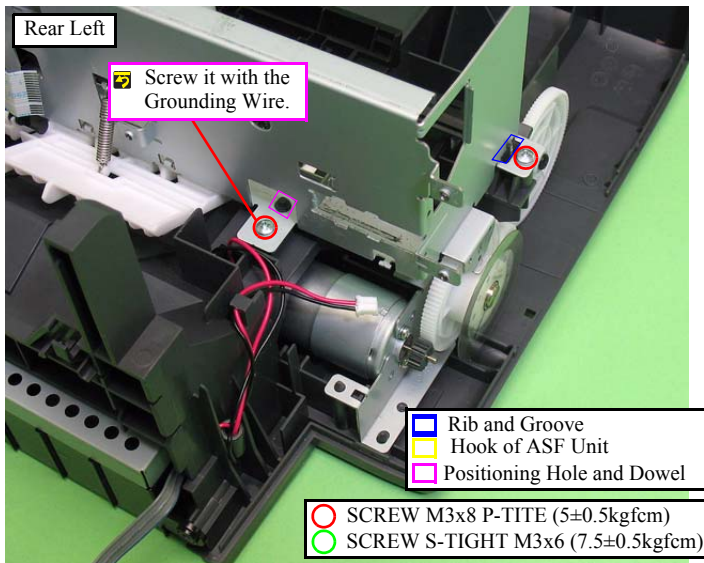
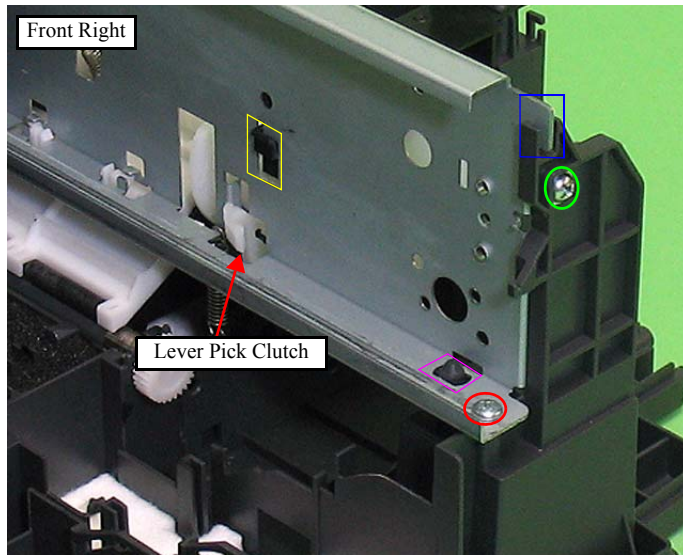


Figure 4-74. Removing the Main Frame (4)



- Do not damage the PF Scale and the Lever Pick Clutch with the Main Frame.
- After removing the Main Frame, do not lay it with the Driven Roller of the Upper Paper Guide facing downward.

7. Remove the Main Frame, the Carriage, and the Upper Paper Guide from the Lower Housing following the procedure below. (See Fig.4-74, Fig.4-75.)

1. Lift the Main Frame until the dowel and the rib that secure the Main Frame comes off.
2. Rotate the Main Frame in the direction of the arrow and remove it not to interfere the Upper Paper Guide with the LD Roller Shaft.

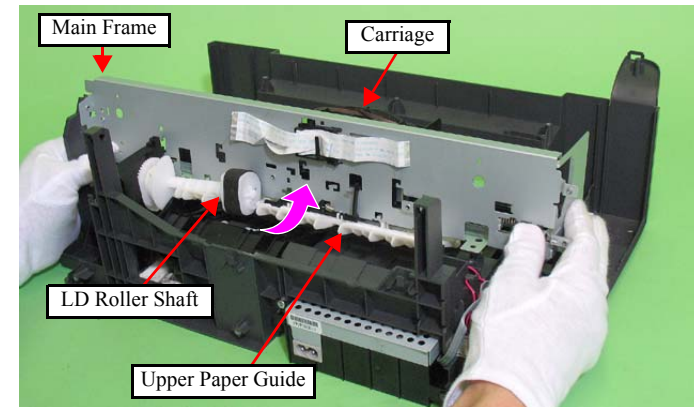


Figure 4-75. Removing the Main Frame (5)



- When installing the Main Frame, align it with the following parts, and secure it with the screws. (See Fig.4-74.)
 - The two ribs of the frame and the two grooves of the Lower Housing
 - The two positioning holes on the lower side of the frame and the two dowels of the Lower Housing
 - The hook of the ASF Unit and the hole of the Main Frame above the Lever Pick Clutch



Whenever the Main Frame is removed/replaced, the required adjustments must be carried out.

- Chapter 5 “ADJUSTMENT” (p.100)

4.5.10 Upper Paper Guide

- Parts/Components need to be removed in advance:
Scanner Stand/Cover Wire (p60), Scanner Unit (p62), Middle Housing(p63)
Panel Unit (p64), Hopper (p72), Main Board (p65)
CR Motor/ Driven Pulley (p75), Ink System(p77), PF Encoder/ PF Scale(p73)
Main Frame (p84)
- Removal procedure

CAUTION



- Be careful not to touch the roller part of the Upper Paper Guide with bare hands to avoid degrading the print quality.
- Do not lay the Upper Paper Guide with the rollers facing downward.

1. Release the six hooks, and remove the Upper Paper Guide from the Main Frame.

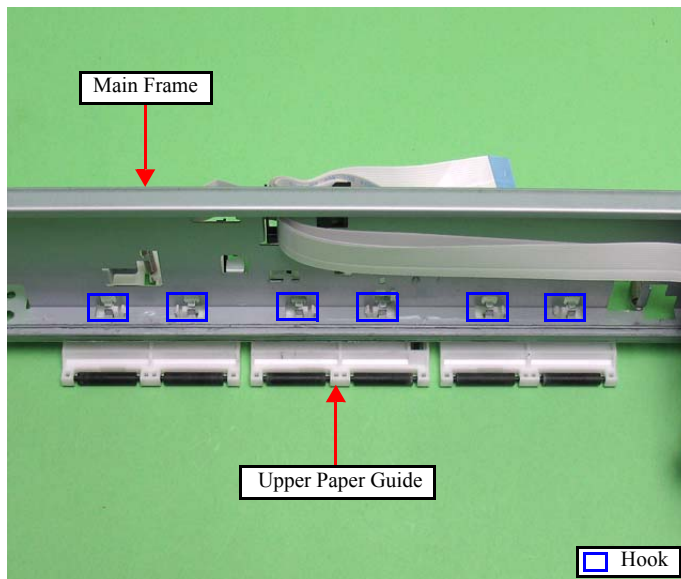


Figure 4-76. Removing the Upper Paper Guide

REASSEMBLY



When replacing the PE Sensor Lever, put the long leg of the lever through the hole of the Upper Paper Guide, and secure the thin part of the lever to the bearing of the Upper Paper Guide.

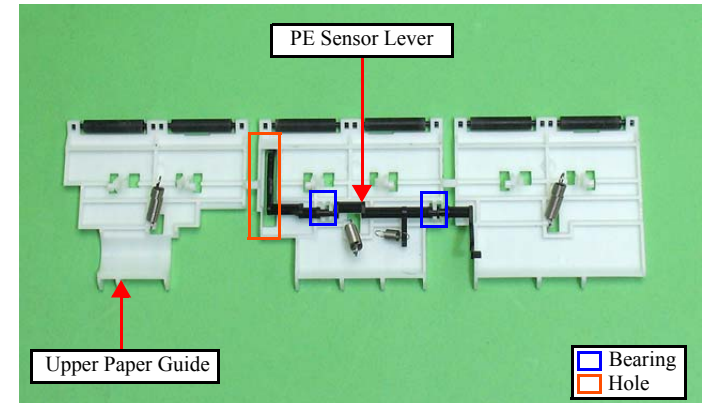


Figure 4-77. Installing the PE Sensor Lever

ADJUSTMENT REQUIRED



Whenever the Upper Paper Guide is removed/replaced, the required adjustments must be carried out.

- Chapter 5 “ADJUSTMENT” (p.100)

4.5.11 CR Unit

- Parts/Components need to be removed in advance:
Scanner Stand/Cover Wire (p 60), Scanner Unit (p 62), Middle Housing (p 63)
Panel Unit (p 64), Printhead (p 68), CR Motor/ Driven Pulley (p 75)
Ink System (p 77), Hopper (p 72), Main Board (p 65)
- Removal procedure
 1. Release the FFC from the Holder FFC, and pull out the FFC through the hole of the Main Frame.

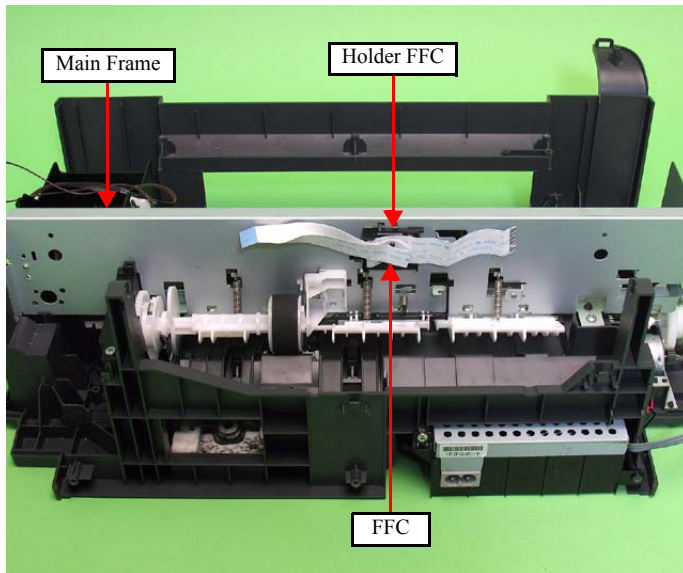


Figure 4-78. Removing the CR Unit (1)

2. Remove the Main Frame. (See "4.5.9 Main Frame (p84)".)
3. Slide the CR Unit in the direction of the arrow, and remove it from the Main Frame.

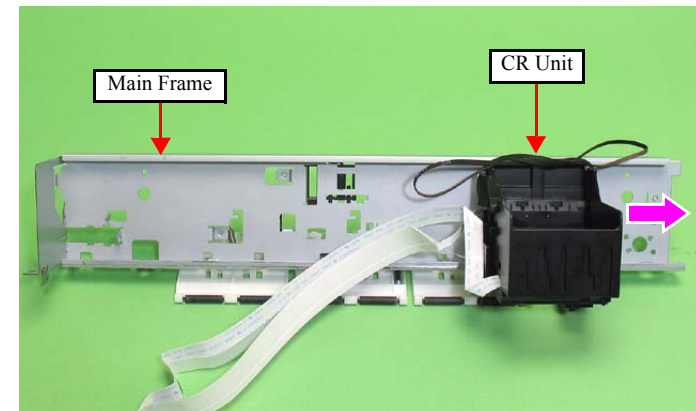


Figure 4-79. Removing the CR Unit (2)

4. Remove the CR Encoder FFC from the CR Encoder Connector.
5. Pull out the Head FFC through the hole of the Carriage, and remove the Head FFC.

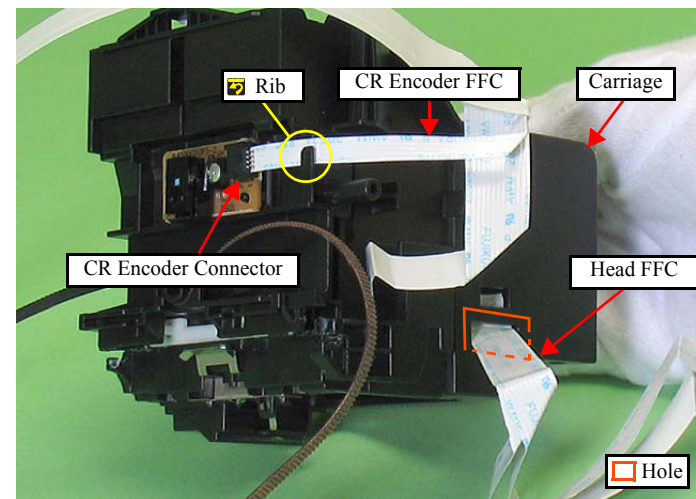


Figure 4-80. Removing the CR Unit (3)

6. Remove the two screws that secure the CR Encoder Board, and remove the CR Encoder Board from the Carriage.
7. Remove the Timing Belt from the Carriage.

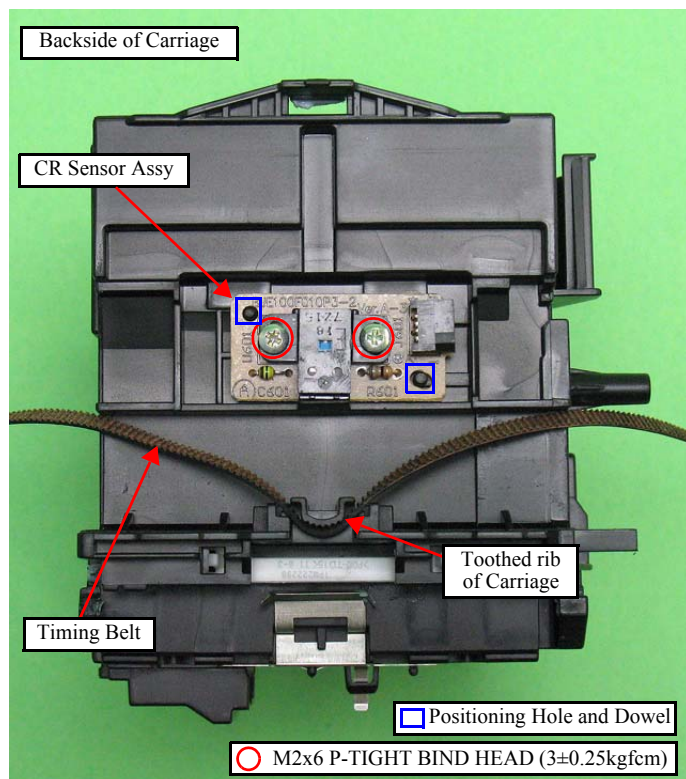


Figure 4-81. Removing the CR Unit (4)



- Align the toothed side of the Timing Belt with the same shaped rib of the Carriage without any twist. (See Fig.4-81.)
- Before installing the CR Encoder Board, align the dowels of the Carriage with the positioning holes of the CR Encoder Board.
- Route the CR Encoder FFC through the rib as shown in Fig.4-80.



- When installing the FFC to the Carriage, route the FFC as shown below.

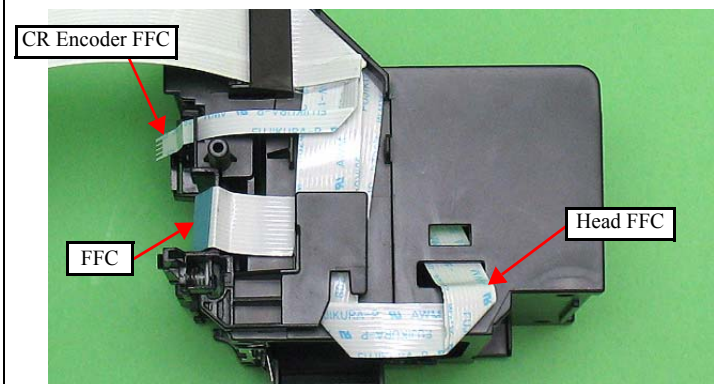


Figure 4-82. Installing the CR Unit (1)

- When replacing the Grounding Plate, Guide Carriage and Compression Spring, install them as shown below.

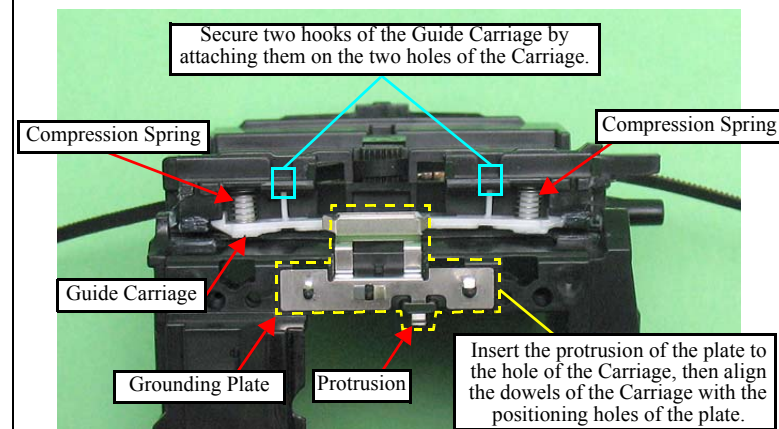


Figure 4-83. Installing the CR Unit (2)

REASSEMBLY

- Install the FFC according to the following procedures.
1. Lead the FFC through the hole of the Holder FFC and Main Frame.

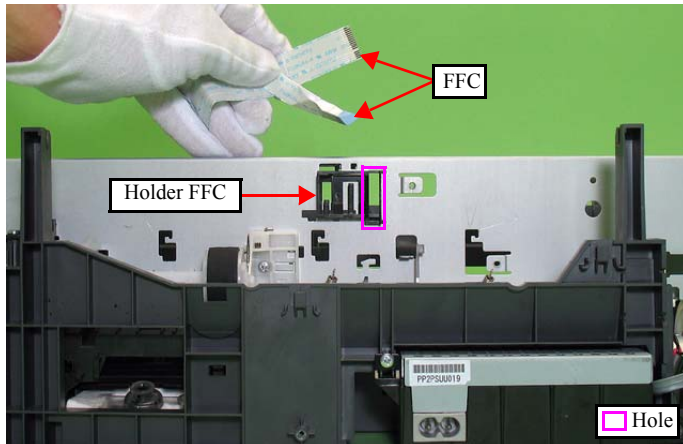


Figure 4-84. Installing the CR Unit (3)

2. Secure the FFC with rib A and rib B.

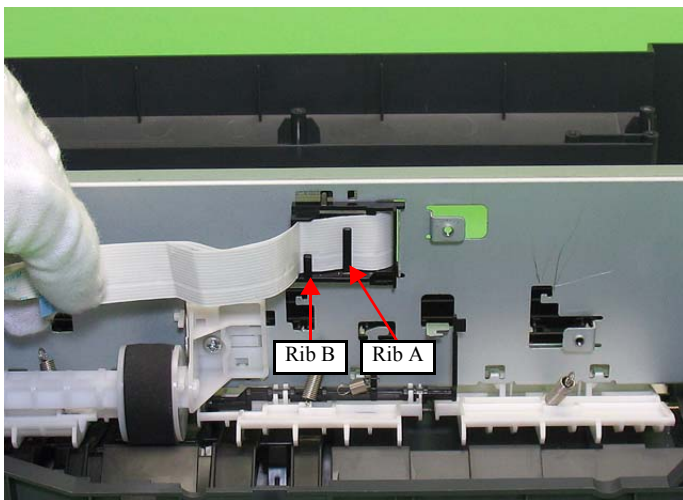


Figure 4-85. Installing the CR Unit (4)

REASSEMBLY

3. Fold back the FFC and secure it with rib A again.

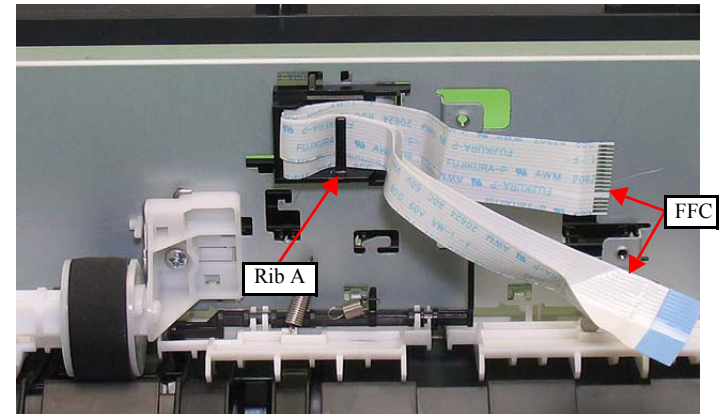


Figure 4-86. Installing the CR Unit (5)

4. Fold back only the Head FFC and secure it with rib A again.
5. Connect the FFC to the Main Board (J8, J9).

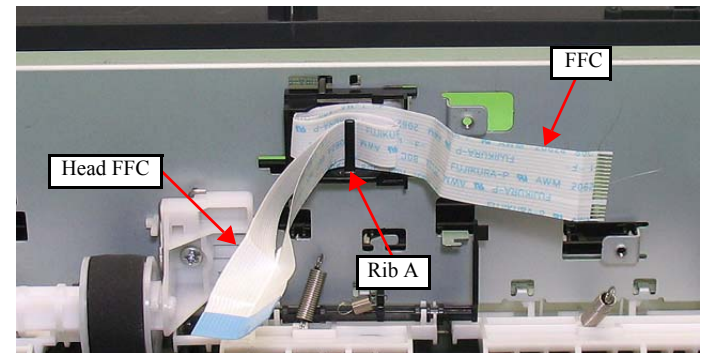


Figure 4-87. Installing the CR Unit (6)

**ADJUSTMENT
REQUIRED**

Whenever the CR Unit is removed/replaced, the required adjustments must be carried out.

- Chapter 5 “ADJUSTMENT” (p.100)

4.5.12 PF Roller

- Parts/Components need to be removed in advance:
Scanner Stand/Cover Wire (p 60), Scanner Unit (p 62), Middle Housing (p 63)
Panel Unit (p 64), Main Board (p 65), EJ Roller/ EJ Frame Assy (p 73)
CR Motor/ Driven Pulley (p 75), Ink System (p 77), Main Frame(p 84)
- Removal procedure

CAUTION



Be careful not to touch the coating part of the PF Roller with bare hands or damage it to avoid degrading the print quality.

1. Remove the screw and then remove the Cover Flashing.
2. Remove the PF Roller Assy from the Lower Housing.

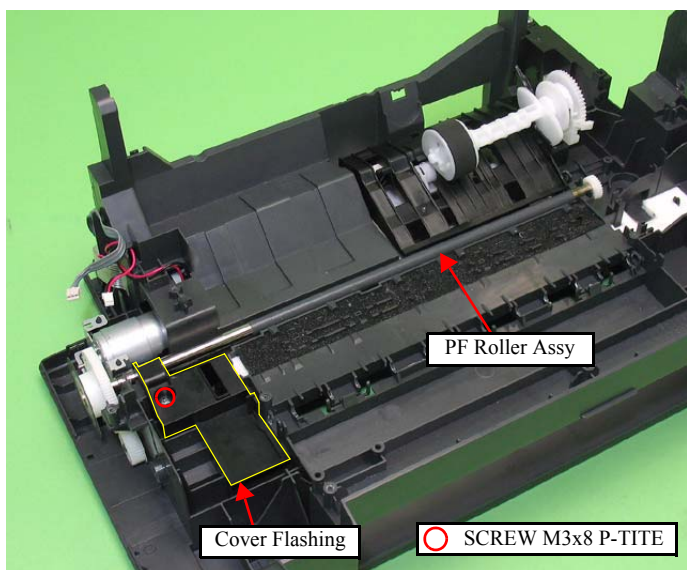


Figure 4-88. Removing the PF Roller Assy

REASSEMBLY



- Before installing the PF Roller, align the groove of the PF Roller Shaft with the rib of the Lower Housing. (See Fig.4-89.)
- Install the Cover Flashing following the procedure below.
 1. Insert the hook of the Cover Flashing through beneath the PF Roller into the hole of the Lower Housing.
 2. Align each groove on the ribs on the rear of the cover with the ribs of the Lower Housing, and secure it with the screw.

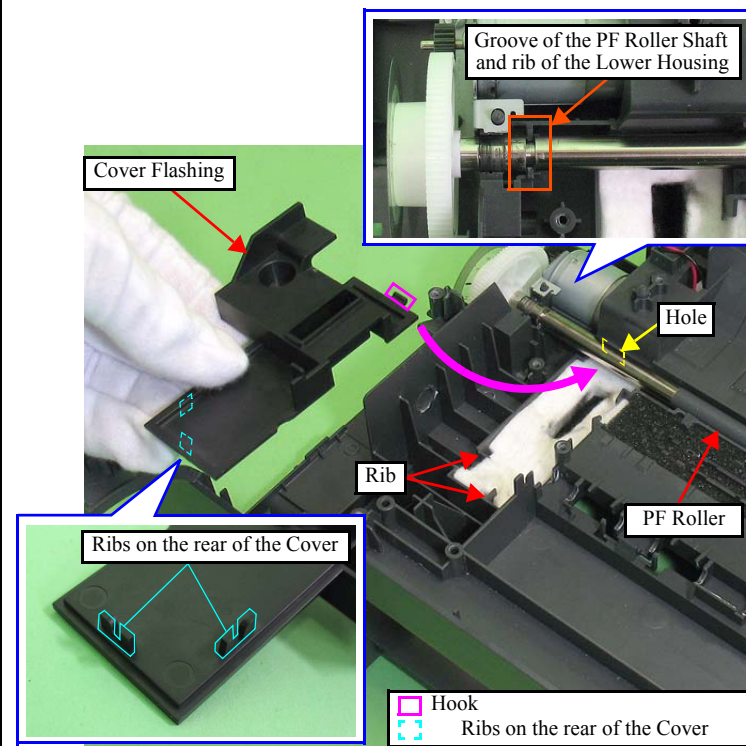


Figure 4-89. Installing the Cover Flashing

ADJUSTMENT REQUIRED

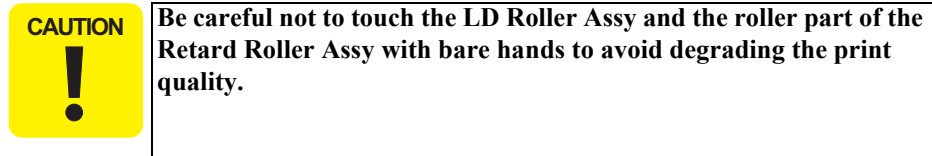


Whenever the PF Roller is removed/replaced, the required adjustments must be carried out.

- Chapter 5 “ADJUSTMENT” (p.100)

4.5.13 LD Roller/ ASF Unit

- Parts/Components need to be removed in advance:
Scanner Stand/Cover Wire (p60), Scanner Unit (p62), Middle Housing (p63)
Panel Unit (p64), Hopper (p72), Main Board (p65)
CR Motor/ Driven Pulley (p75), Ink System(p77), PF Encoder/ PF Scale(p73)
Main Frame (p84)
- Removal procedure



1. Rotate the LD Roller Assy until the flat part of the LD Roller Assy faces upward.
2. Hold the Paper Back Lever outward using tweezers as shown below.
3. Remove the LD Roller Assy from the ASF Unit Shaft Hole while opening the Lever Pick Clutch as shown below.

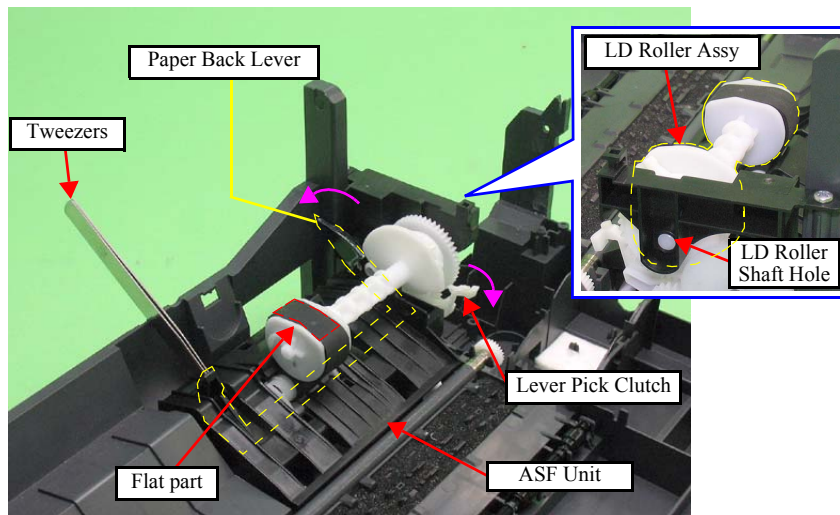


Figure 4-90. Removing the LD Roller Assy

4. Remove the three screws that secure the ASF Unit.
5. Release the hook and remove the ASF Unit from the Lower Housing.

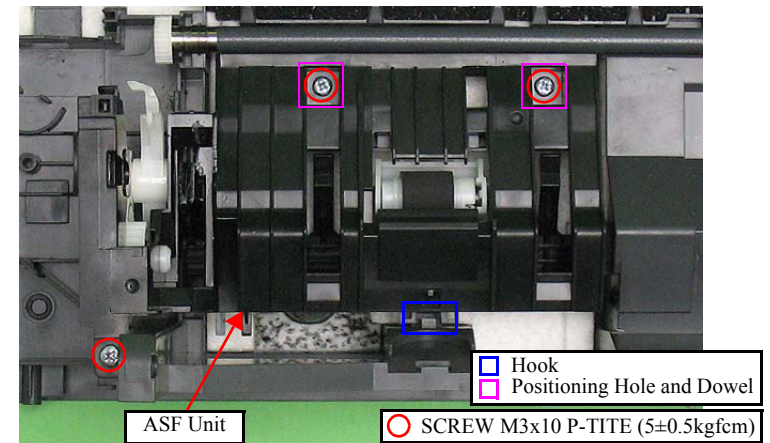


Figure 4-91. Removing the ASF Unit

6. Remove the Extension Spring at the bottom of the Retard Roller Assy.
7. Remove the Retard Roller Assy from the ASF Housing.

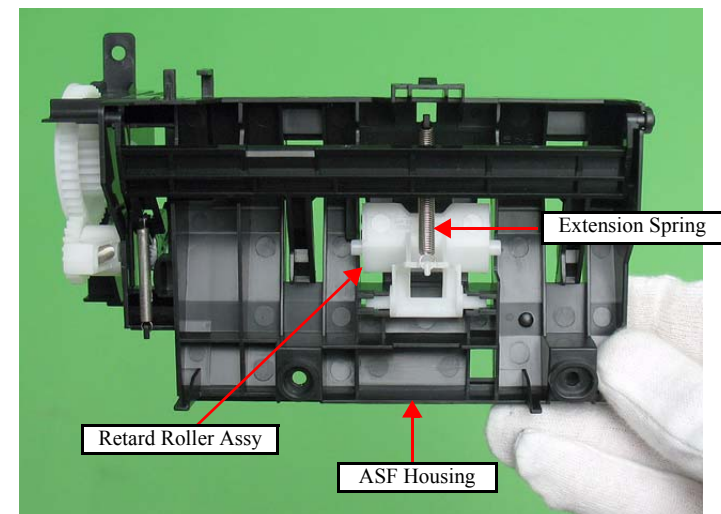


Figure 4-92. Removing the Retard Roller Assy

8. Release the hook of the Combination Gear, and remove the gear from the ASF Housing.
9. Remove the Lever Pick Clutch from the ASF Housing.

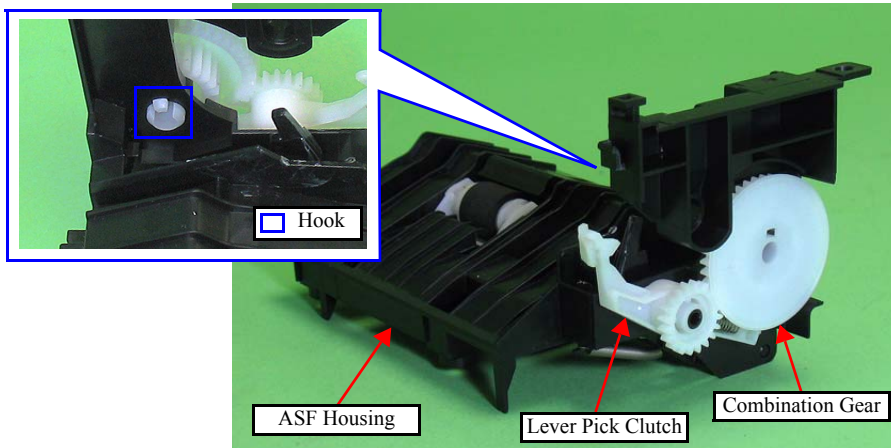


Figure 4-93. Removing the Lever Pick Clutch

10. Disengage the Lever Clutch Spring from the ribs of the Change Lever, and remove the Lever Clutch Spring.
11. Remove the Lever Idle Gear from the Change Lever.

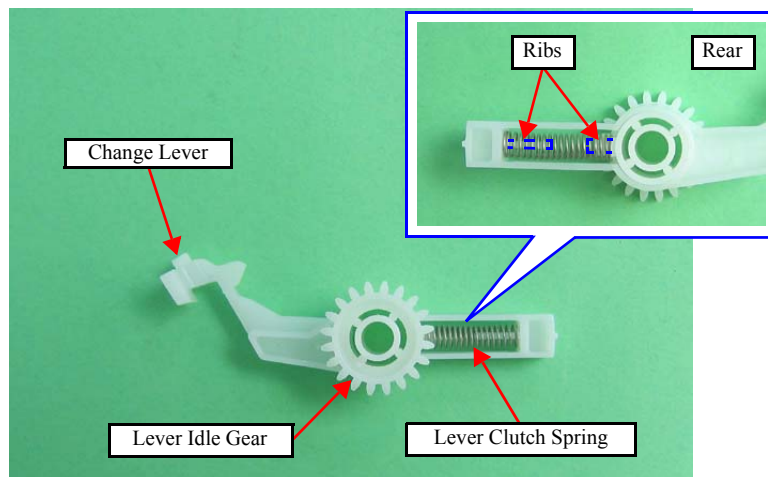


Figure 4-94. Removing the Change Lever



- When installing the ASF Unit, insert the guide pin of the Lower Housing to the positioning hole of the unit, and secure the unit with the hook of it and the three screws. (See Fig.4-91.)
- When installing the LD Roller Assy and the ASF Unit, make sure to engage the cam face of the LD Roller Assy and that of the Paper Back Lever.

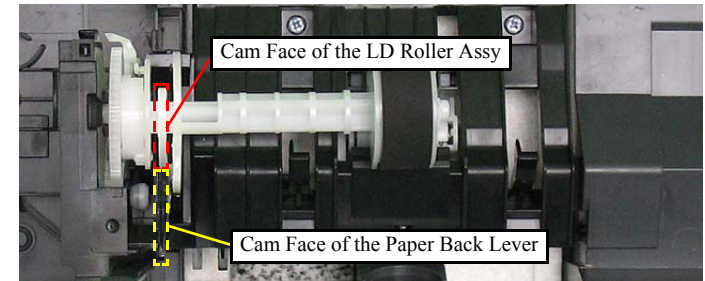


Figure 4-95. Installing the ASF Unit

- When installing the LD Roller to the LD Roller Assy, make sure to attach it with the arrow inside as shown below.

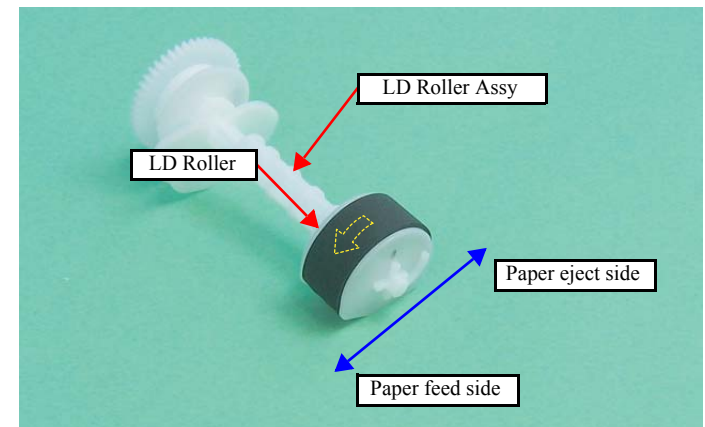


Figure 4-96. Assembling the LD Roller Assy (1)

REASSEMBLY



■ Assemble the LD Roller Assy following the procedure below.

1. Install the Clutch while aligning the guide pin of the LD Roller Shaft with the hole of the Clutch.
2. Install the Extension Spring between the hook of the LD Roller Shaft and that of the Clutch.
3. Install the Combination Gear to the LD Roller Shaft.

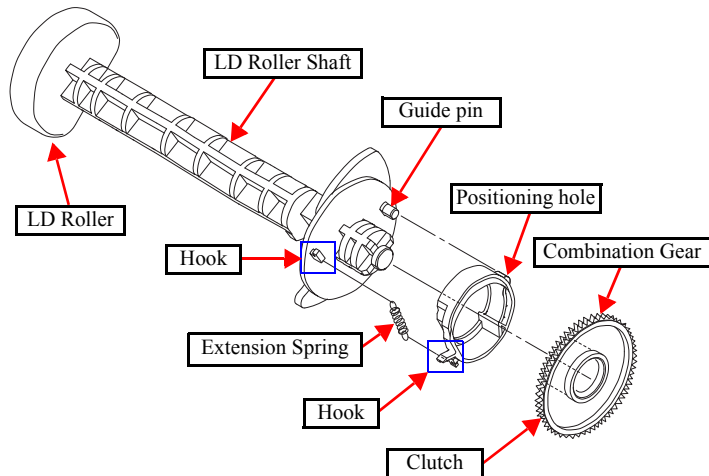


Figure 4-97. Assembling the LD Roller Assy (2)

■ When installing the Retard Roller to the Retard Roller Assy, make sure to attach it with the arrow inside as shown below.

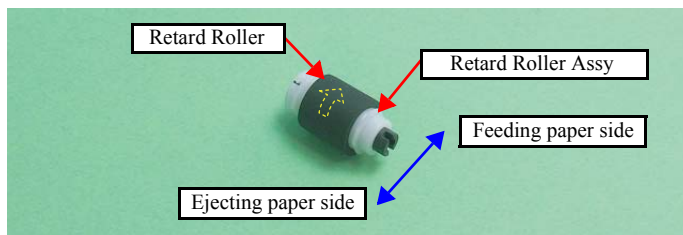


Figure 4-98. Assembling the Retard Roller Assy

4.5.14 Waste Ink Pads

- Parts/Components need to be removed in advance:
Scanner Stand/Cover Wire (p60), Scanner Unit (p62), Middle Housing (p63)
Panel Unit (p64), Main Board (p65), EJ Roller/ EJ Frame Assy (p73)
CR Motor/ Driven Pulley (p75), Ink System (p77), Main Frame (p84)
PF Roller (p90), LD Roller/ ASF Unit (p91)
- Removal procedure
 1. Remove the Waste Ink Pads (A - F) from the Lower Housing.

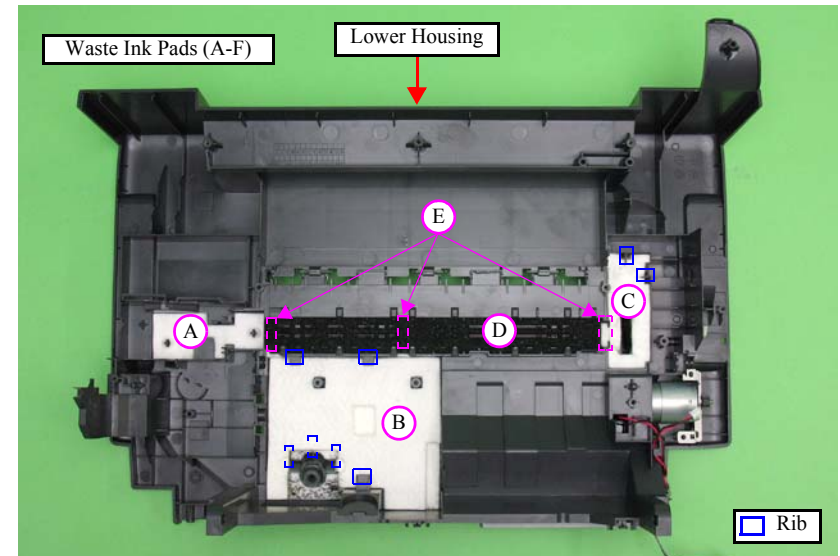


Figure 4-99. Removing the Waste Ink Pads

ADJUSTMENT
REQUIRED

Whenever the ASF Unit is removed/replaced, the required adjustments must be carried out.

- Chapter 5 “ADJUSTMENT” (p.100)

REASSEMBLY



- When installing the Waste Ink Pads, align the ribs of the Lower Housing with the notches of the Waste Ink Pads. (See Fig.4-99.)
- When installing the Diffusion Sheet in the section B, install the Waste Ink Cover and the Waste Ink Pads (x3) in the order shown below.

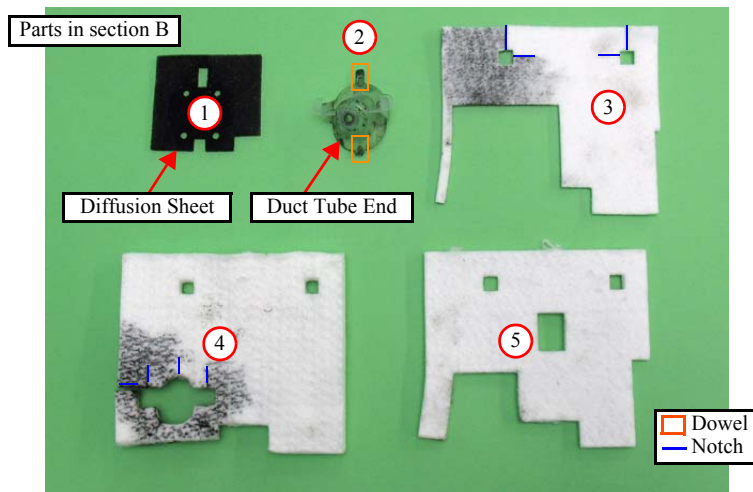


Figure 4-100. Installing the Waste Ink Pads (1)

- When installing the Diffusion sheet and the Waste Ink Cover in the section B, be sure to align their dowels with the positioning holes of the Lower Housing, then secure them without any gap.
- Install the Waste Ink Pads (x2) in the section C in the order shown below.

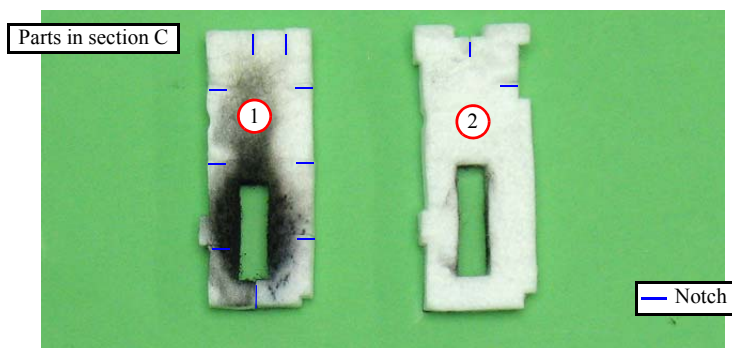


Figure 4-101. Installing the Waste Ink Pads (2)

REASSEMBLY



- Put double-sided tape (8mm x 30mm) on the Lower Housing as shown below to secure the Waste Ink Pad A, B and the Waste Ink Pad E on the 0-column side.
 - Waste Ink Pad A: 2 points (■)
 - Waste Ink Pad B and Waste Ink Pad E on the 0-column side together: 1 point (■)

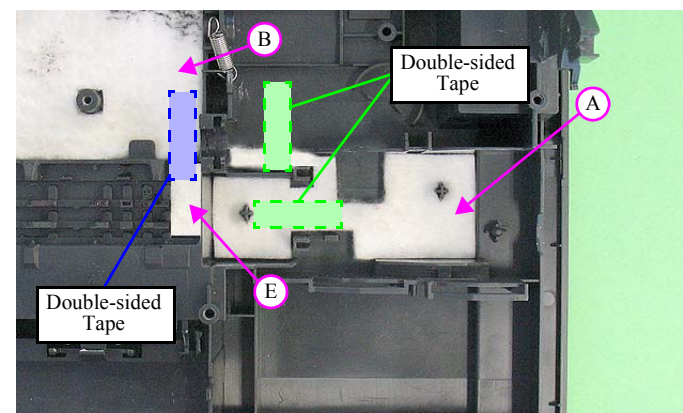


Figure 4-102. Installing the Waste Ink Pads (3)

- When installing the Waste Ink Pad E, align it to the surface of the Lower Housing not to let the pads protrude.

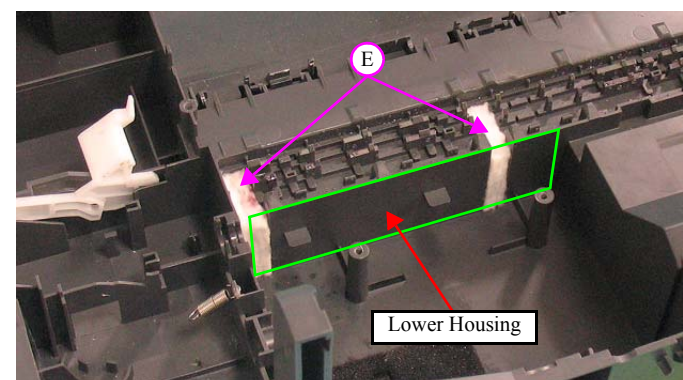


Figure 4-103. Installing the Waste Ink Pads (4)

REASSEMBLY

- When installing the Waste Ink Pad D, make sure to fit it evenly 1.5mm lower than the platen surface of the Lower Housing.
- If the Lower Housing is contaminated with the liquid of the Waste Ink Pad D, make sure to wipe it off with alcohol.

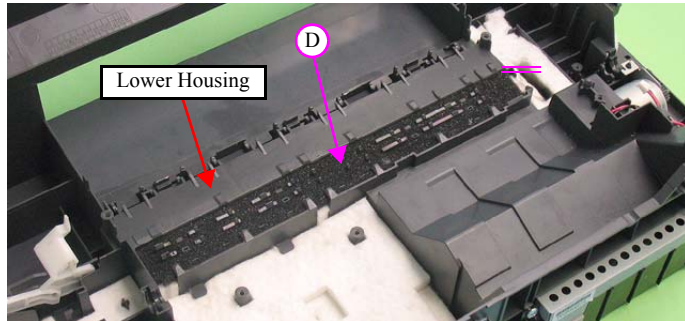


Figure 4-104. Installing the Waste Ink Pads (5)

**ADJUSTMENT
REQUIRED**

Whenever the Waste Ink Pads removed/replaced, the required adjustments must be carried out.

- [Chapter 5 “ADJUSTMENT” \(p.100\)](#)

4.6 Disassembling the Scanner Unit

4.6.1 Upper Scanner Housing

- Parts/Components need to be removed in advance:
Document Cover/ASF Cover (p59), Scanner Unit (p62)
- Removal procedure

CAUTION


- Following work should be performed in a room where there is a little dust. A clean room or a clean bench would be preferable.
- Do not scratch the Rod Lens Array when removing the CIS Assy.

CHECK POINT


If the Spacer or the Driven Pulley comes off when disassembling the Scanner Unit, make sure to assemble the part referring to Fig.4-105 and Fig.4-113.

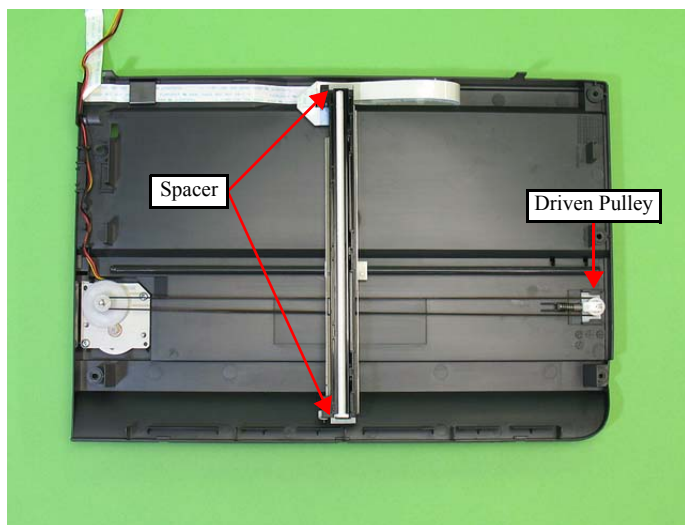


Figure 4-105. Installing the Spacer or the Driven Pulley

1. Remove the five screws that secure the Upper Scanner Housing and the eight hooks inside the Lower Scanner Housing, and remove the Upper Scanner Housing.



Figure 4-106. Removing the Upper Scanner Housing



When assembling the Upper Scanner Housing, confirm that the Spacer is attached correctly. (See Fig.4-105 and Fig.4-113.)

4.6.2 Scanner Carriage Unit

- Parts/Components need to be removed in advance:
Document Cover/ASF Cover (p59), Scanner Unit (p62)
Upper Scanner Housing (p96)
- Removal procedure

CAUTION


Do not scratch the Rod Lens Array when removing the Scanner Carriage Unit.

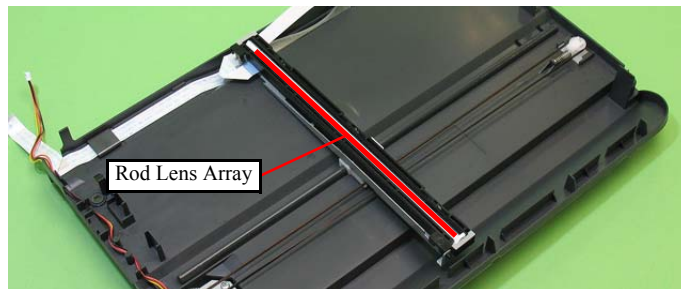


Figure 4-107. Handling the Scanner Carriage Unit

1. Move the Scanner Carriage Unit to the center.
2. Remove the two Spacers from the Scanner Carriage Unit.

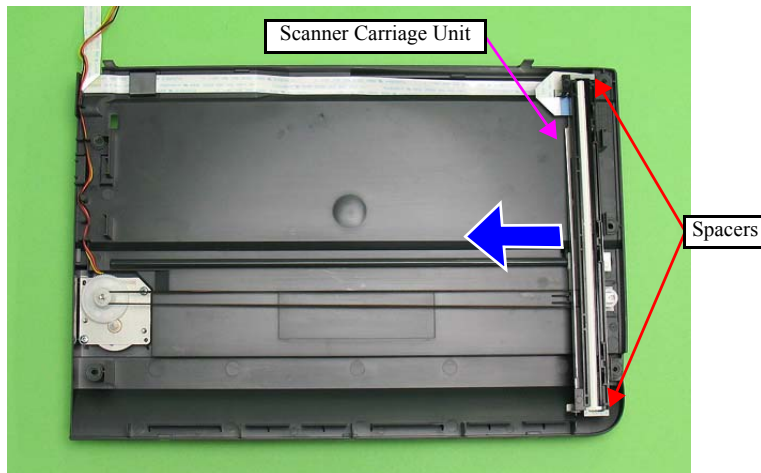


Figure 4-108. Moving the Scanner Carriage Unit

CAUTION


Take extra care not to contaminate the Scanner Timing Belt with grease on the rail of the Lower Scanner Housing.

3. Loosen the Scanner Timing Belt by pressing the Driven Pulley in the direction of the arrow, and remove the Scanner Timing Belt from the Combination Gear and Driven Pulley.

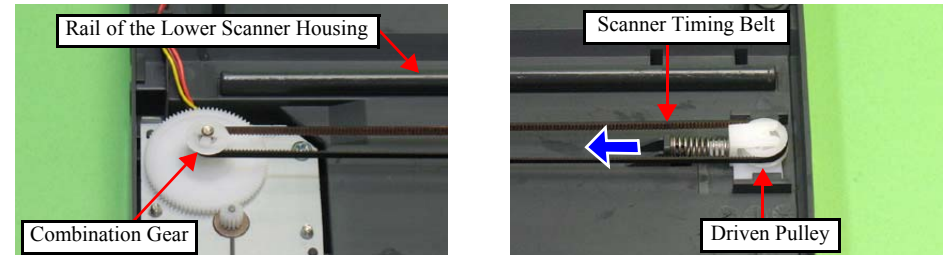


Figure 4-109. Removing the Scanner Carriage Unit (1)

CAUTION


Be careful about the double-sided tape fixing the Scanner Carriage FFC.

4. Peel off the Scanner Carriage FFC from the Scanner Carriage Unit, and remove the Scanner FFC from the connector of the CIS Unit.
5. Remove the Scanner Carriage Unit together with the Scanner Timing Belt.

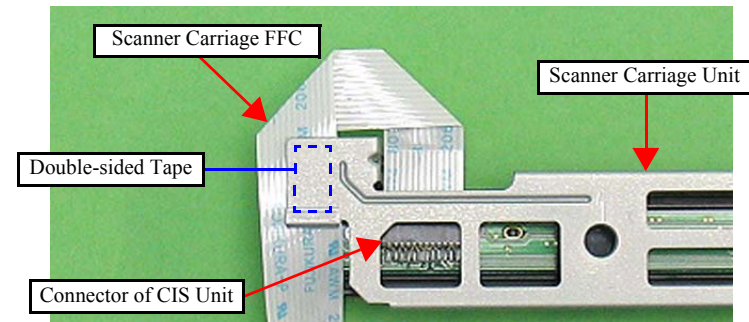


Figure 4-110. Removing the Scanner Carriage Unit (2)

6. Disengage the shafts on both ends of the CIS Unit from the bearing holes of the Scanner CR Holder, and remove the unit.

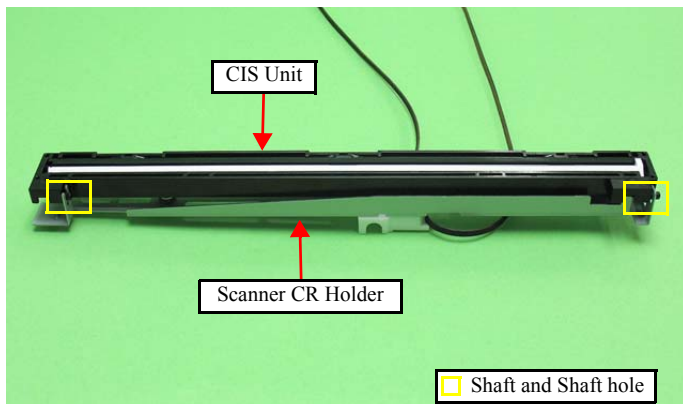


Figure 4-111. Removing the CIS Unit



- Install the CIS springs (x2) to the dowels of the Scanner CR Holder. (See Fig.4-112.)

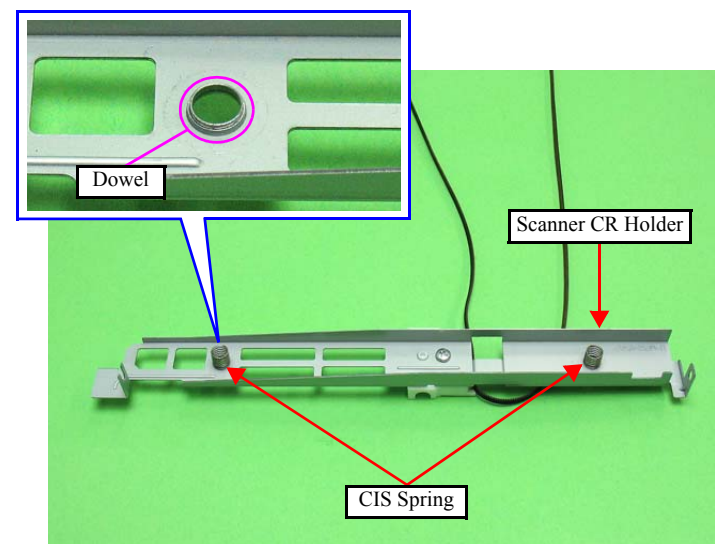


Figure 4-112. Installing the CIS Spring

- When installing the spacers, be sure to place them with the cutout facing inward. (See Fig.4-113.)

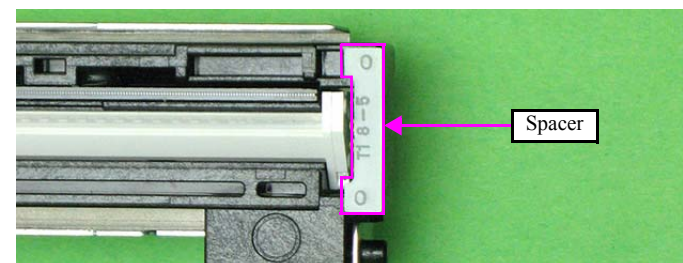


Figure 4-113. Replacing the Spacers

4.6.3 Scanner Motor Unit

- Parts/Components need to be removed in advance:
Document Cover/ASF Cover (p59), Scanner Unit (p62)
Upper Scanner Housing (p96)
- Removal procedure
 1. Move the Scanner Carriage Unit to the center.
(Refer to 4.6.2 Scanner Carriage Unit Step1 (p97))
 2. Loosen the Scanner Timing Belt by pressing the Driven Pulley and remove the Scanner Timing Belt from the Combination Gear and the Driven Pulley.
(Refer to 4.6.2 Scanner Carriage Unit Step3 (p97))
 3. Release the Scanner Motor cable from the ribs at the bottom of the Scanner Housing.
 4. Remove the two screws that secure the Scanner Motor Unit, and remove the Scanner Motor Unit.



- When installing the Scanner Motor Unit, align each dowel at the bottom of the Scanner Housing with their positioning holes of the Scanner Motor Unit. (See Fig.4-114.)
- Route the Scanner Motor cable through the three ribs and the two protrusions at the bottom of the Scanner Housing. (See Fig.4-114.)

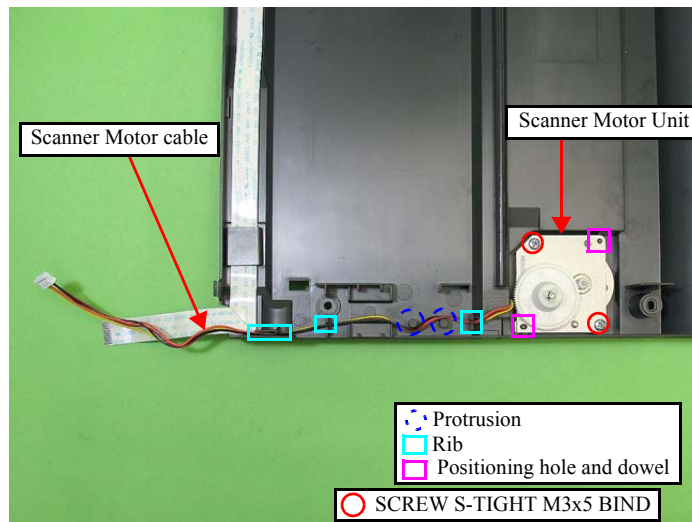


Figure 4-114. Removing the Scanner Motor Unit

CHAPTER

5

ADJUSTMENT

5.1 Adjustment Items and Overview

This chapter describes adjustments required after the disassembly/reassembly of the printer.

5.1.1 Servicing Adjustment Item List (TBD)

The adjustment items of this product are as follows.



For information on how to carry out the adjustments and media required for the adjustments, see the instructions displayed by the Adjustment Program.

Table 5-1. Adjustment Items

Adjustment Item	Purpose	Method Outline	Tool
EEPROM data copy	When the main board needs to be replaced, use this to copy adjustment values stored on the old main board to the new board. If this copy is completed successfully, all the other adjustments required after replacing the main board are no longer necessary.	Readout the EEPROM data from the main board before removing it. Then replace the board with a new one, and load the EEPROM data to the new board.	• Adjustment Program
Initial setting	This must be carried out after replacing the main board to apply settings for the target market.	Select the target market. The selected market settings are automatically written to the main board.	• Adjustment Program
USB ID input	This sets a USB ID of the printer. A computer identifies the printer by the ID when multiple same models are connected via a USB hub.	Enter the product serial number of the printer. The ID is automatically generated and written to the main board.	• Adjustment Program
Head ID input	This must be carried out after replacing the Printhead in order to enter the new Printhead ID (Head ID) that reduces variation between Printheads.	Enter the ID (11-digit) printed on the Head QR code label attached on the Printhead. The correction values are automatically written to the main board.	• Adjustment Program
TOP margin adjustment	This corrects top margin of printout.	A top margin adjustment pattern is printed. Examine the lines printed near the top edge of the printout, and enter the value for the line that is exactly 3 mm away from the top edge.	• Adjustment Program • Ruler
First dot position adjustment	This corrects left margin of printout. The print start position in the carriage moving direction is corrected by software.	A first dot adjustment pattern is printed. Examine the lines printed near the left edge of the printout and enter the value for the line that is exactly 5 mm away from the left edge.	• Adjustment Program • Ruler
Head angular adjustment	This must be carried out after replacing the Printhead in order to correct tilt of the Printhead by software.	A head angular adjustment pattern is printed. Examine the printed lines and enter the value for the most straight lines.	• Adjustment Program
Bi-D adjustment	This corrects print start timing in bi-directional printing to improve the print quality.	A Bi-D adjustment pattern is printed. the pattern are printed for each of the four dot sizes. So, there are four groups. Examine the patterns and enter the value for the pattern without any gap or overlap for each mode.	• Adjustment Program
CR motor heat protection control	This must be carried out for efficient heat control of the CR motor. Electrical variation of the motor and the power supply board are measured to acquire correction values for them.	Select the parts that you replaced. The correction values are automatically written to the main board.	• Adjustment Program
PF adjustment	This corrects variations in paper feed accuracy to achieve higher print quality.	A PF adjustment pattern is printed. Examine the printout patterns and enter the value for the best pattern to register the correction value to the printer.	• Adjustment Program

Table 5-2. Maintenance Items

Maintenance Item	Purpose	Method Outline	Tool
Waste ink pad counter	The printer indicates a maintenance error when the waste ink pad counter reaches its maximum. Use this to reset the counter after replacing the Waste Ink Pad. If you find the counter is close to the maximum level during servicing, carry out the pad replacement and the counter reset to avoid the printer's immediate return from the user due to the maintenance error.	After replacing the Waste Ink Pad, reset the counter to its default.	• Adjustment Program
Ink charge	This must be carried out after replacing the Printhead in order to fill ink inside the new Printhead. The Printhead becomes ready for print.	Filling ink inside the Printhead is automatically performed. Print a nozzle check pattern to check if all nozzles fire ink properly.	• Adjustment Program

Table 5-3. Additional Functions

Additional Functions	Purpose	Method Outline	Tool
Final check pattern print	A4 size	Use this to check if all the adjustments have been properly made.	all the adjustment patterns are printed automatically.
	US Letter size		
EEPROM dump	Use this to readout the EEPROM data for analysis.	all the EEPROM data is automatically readout and stored as a file.	• Adjustment Program
Printer information check	Manual CL counter	Use this to readout information on the printer operations.	The printer information is automatically readout.
	I/C exchange CL counter		
	Timer CL counter		
	Print path counter		

5.1.2 Required Adjustments (TBD)

The table below lists the required adjustments depending upon the parts being repaired or replaced. Find the part(s) you removed or replaced, and check which adjustment(s) must be carried out.

Table 5-4. Required Adjustment List

Priority		1	2	3	4	5	6	7	8	9	10	11	12
Part Name	Adjustment Item	EEPROM data copy	Initial setting	USB ID input	Waste ink pad counter	Ink charge	Head ID input	Top margin adjustment	First dot position adjustment	Head angular adjustment	Bi-D adjustment	CR motor heat protection control	PF adjustment
	Main board unit	Remove	---	---	---	---	---	---	0	0	0	0	---
Replace (Read OK)		0	---	---	---	---	---	--	---	--	---	---	---
Replace (Read NG)		---	0	0	0 (Replace the pad)	---	0	0	0	0	0	0	0
Printhead	Remove	---	---	---	---	---	---	0	0	0	0	---	0
	Replace	---	---	---	---	0	0	0	0	0	0	---	0
Power Supply unit	Remove	---	---	---	---	---	---	0	0	0	0	---	0
	Replace	---	---	---	---	---	---	0	0	0	0	0	0
Hopper	Remove	---	---	---	---	---	---	0	0	0	0	---	0
	Replace	---	---	---	---	---	---	0	0	0	0	---	0
CR motor	Remove	---	---	---	---	---	---	0	0	0	0	---	0
	Replace	---	---	---	---	---	---	0	0	0	0	0	0
EJ roller	Remove	---	---	---	---	---	---	0	0	0	0	---	0
	Replace	---	---	---	---	---	---	0	0	0	0	---	0
Main frame	Remove	---	---	---	---	---	---	0	0	0	0	---	0
	Replace	---	---	---	---	---	---	0	0	0	0	0	0
ASF unit	Remove	---	---	---	---	---	---	0	0	0	0	---	0
	Replace	---	---	---	---	---	---	0	0	0	0	---	0
CR unit	Remove	---	---	---	---	---	---	0	0	0	0	---	0
	Replace	---	---	---	---	---	---	0	0	0	0	---	0

Table 5-4. Required Adjustment List

Priority		1	2	3	4	5	6	7	8	9	10	11	12
Adjustment Item		EEPROM data copy	Initial setting	USB ID input	Waste ink pad counter	Ink charge	Head ID input	Top margin adjustment	First dot position adjustment	Head angular adjustment	Bi-D adjustment	CR motor heat protection control	PF adjustment
Part Name													
Upper paper guide	Remove	---	---	---	---	---	---	O	O	O	O	---	O
	Replace	---	---	---	---	---	---	O	O	O	O	---	O
PF roller	Remove	---	---	---	---	---	---	O	O	O	O	---	O
	Replace	---	---	---	---	---	---	O	O	O	O	---	O
Waste ink pad	Remove	---	---	---	---	---	---	O	O	O	O	---	---
	Replace	---	---	---	O	---	---	O	O	O	O	---	---
Ink System	Remove	---	---	---	---	---	---	O	O	O	O	---	O
	Replace	---	---	---	---	---	---	O	O	O	O	---	O
PF Motor	Remove	---	---	---	---	---	---	O	O	O	O	---	O
	Replace	---	---	---	---	---	---	O	O	O	O	---	O
PF Encoder/PF Scale	Remove	---	---	---	---	---	---	O	O	O	O	---	O
	Replace	---	---	---	---	---	---	O	O	O	O	---	O
CR Scale	Remove	---	---	---	---	---	---	O	O	O	O	---	O
	Replace	---	---	---	---	---	---	O	O	O	O	---	O

CAUTION

- When the EEPROM data copy is impossible with the main board that needs to be replaced, the Waste Ink Pad must be replaced after replacing the main board with a new one.
- After all required adjustments are completed, use the “Final check pattern print” function to print all adjustment patterns for final check. If you find a problem with the printout patterns, carry out the adjustment again.
- When using a new main board for replacing the Printer Mechanism, the initial setting must have been made to the main board.

<Meaning of the marks in the table>

“O” indicates that the adjustment must be carried out. “---” indicates that the adjustment is not required.

If you have removed or replaced multiple parts, make sure to check the required adjustments for all the parts. And when multiple adjustments must be carried out, be sure to carry them out in the order given in the “Priority” row.

5.2 Using the Adjustment Program (TBD)

This section describes how to judge the adjustment patterns printed by the Adjustment Program. For information on how to operate the Adjustment Program, see the instructions displayed by the Adjustment Program.

5.2.1 TOP Margin Adjustment

The following pattern is printed.

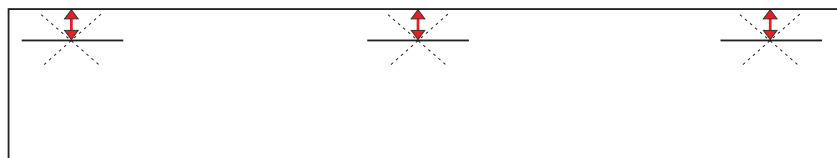


Figure 5-1. Top Margin Adjustment Printout Pattern

How to Judge

Measure the length from the top edge of the paper to the printed line. Select a value from the combobox according to the following standard.

Measurement result	Selection of adjustment value
3.7 to 5.1mm	Choose the “-” from a combobox.
2.3 to 3.7mm	Choose the “0” from a combobox.
0.9 to 2.3mm	Choose the “+” from a combobox.

5.2.2 First Dot Position Adjustment

The following pattern is printed.



Figure 5-2. First Dot Position Adjustment Printout Pattern

How to judge

Measure the length from the left edge of the paper to the printed line. Select a value from the combobox according to the following standard.

Measurement result	Selection of adjustment value
5.7 to 7.1mm	Choose the “-” from a combobox.
4.3 to 5.7mm	Choose the “0” from a combobox.
2.9 to 4.3mm	Choose the “+” from a combobox.

5.2.3 Head Angular Adjustment

The following pattern is printed.



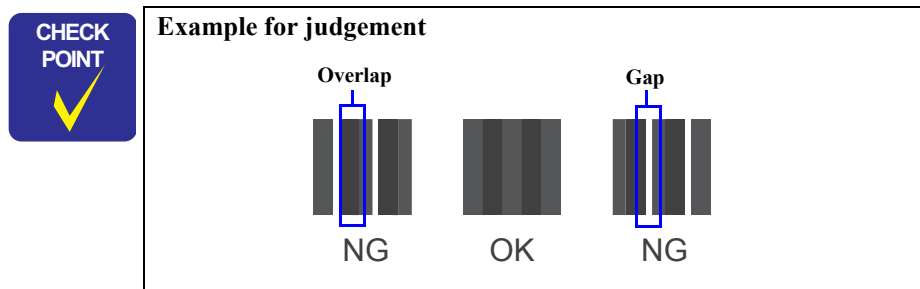
Figure 5-3. Head angular adjustment Pattern Printing

How to Judge

Examine the printout patterns, and enter the value for the pattern without any gap or overlap.

Additional Information

If there is no OK pattern printed, enter the value for the best one, and print the adjustment pattern again.



5.2.4 Bi-D Adjustment

The following pattern is printed for each of the four print modes (four dot size modes).

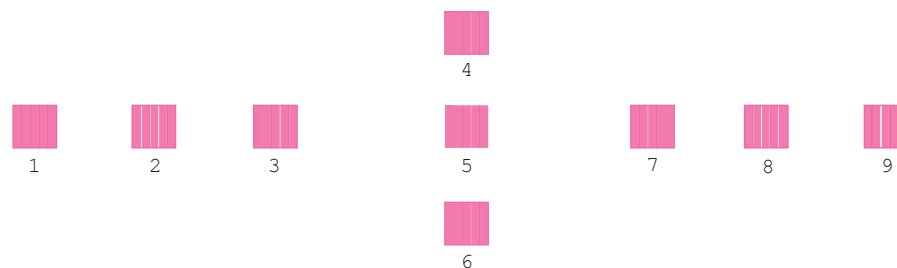


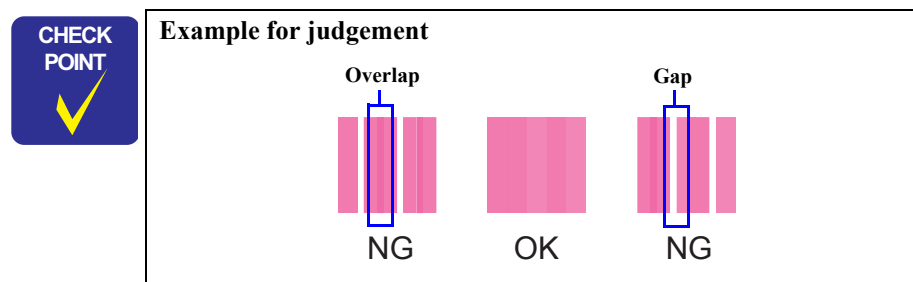
Figure 5-4. Bi-D Adjustment Printout Pattern

How to Judge

Examine the printout patterns for each of the four modes, and enter the value for the pattern without any gap or overlap for each mode.

Additional Information

If there is no OK pattern printed, enter the value for the best one, and print the adjustment pattern again.



5.2.5 PF Adjustment

Black



Color

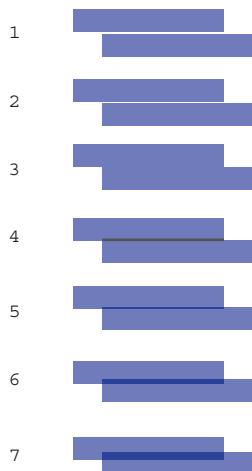


Figure 5-5. PF Band Adjustment Printout Pattern

How to Judge

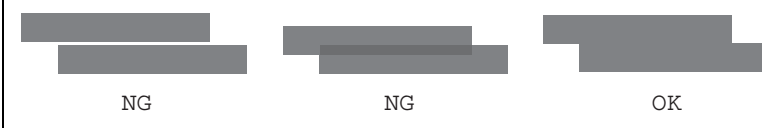
Examine the printout patterns and enter the value for the pattern without any overlap or gap between the two rectangles.

Additional Information

If overlaps or gaps are observed in all the patterns, enter the value for the best one, and print the adjustment pattern again.



Example for judgement



CHAPTER

6

MAINTENANCE

6.1 Overview

This section provides information to maintain the printer in its optimum condition.

6.1.1 Cleaning

This printer has no mechanical components which require regular cleaning except the Printhead. Therefore, when returning the printer to the user, check the following parts and perform appropriate cleaning if stain is noticeable.


CAUTION

- Never use chemical solvents, such as thinner, benzine, and acetone to clean the exterior parts of the printer like the Housing. These chemicals may deform or deteriorate the components of the printer.
- Be careful not to damage any components when you clean inside the printer.
- Do not scratch the coated surface of the PF roller. Use a soft brush to wipe off any dusts.
- Use a soft cloth moistened with alcohol to remove the ink stain.
- When using compressed air products; such as air duster, for cleaning during repair and maintenance, the use of such products containing flammable gas is prohibited.

- Exterior parts
Use a clean soft cloth moistened with water, and wipe off any dirt. If the exterior parts are stained by the ink, use a cloth moistened with neutral detergent to wipe it off.
- Inside the printer
Use a vacuum cleaner to remove any paper dust.
- LD Roller
When paper loading function does not operate because friction of the LD roller is lowered by any paper dust, use a soft cloth moistened with alcohol to remove the paper dust.

6.1.2 Service Maintenance

If any abnormal print (dot missing, white line, etc.) has occurred or the printer indicates the “Maintenance request error” (This error is displayed as “Service Required” in the STM3), take the following actions to clear the error.

6.1.2.1 Printhead cleaning

When dot missing or banding phenomenon has occurred, you need to perform the Printhead cleaning operation* by using the Printhead cleaning function. This function can be performed by the control panel operation, the printer driver utility and the Adjustment program.

* : Epson STYLUS NX100/NX105/SX100/SX105/TX100/TX101/TX102/TX103/TX105/TX106/TX109/ME 300 have three modes for manual cleaning, and even during printing, the appropriate cleaning mode is automatically selected and performed according to various conditions. Therefore the ink consumption amount for manual cleaning varies depending on each mode.

6.1.2.2 Maintenance request error

Ink is used for the Printhead cleaning or cap flushing operation as well as the printing operation. When the ink is used for the Printhead cleaning or flushing operation, the ink is drained via the pump to the Waste ink pads. The amount of the waste ink is stored as the waste ink counter into the EEPROM on the Main Board. Due to this, when the waste ink counter has reached the limit of the absorbing capability of the Waste ink pads, the Maintenance call error is indicated on Status monitor 3. However, the limit value of the waste ink counter varies according to the usage.


CHECK POINT

Refer to following chapter about indication of the maintenance request error.

- [Chapter 3 TROUBLESHOOTING \(p.27\)](#)

When the maintenance request error has occurred, replace the waste ink pad with new one and clear the waste ink counter stored into the EEPROM. If the waste ink counter is closed to its limit, we recommend to replace the Waste ink pad with new one. This is because the Maintenance request error will may occur after returning the repaired product to the customer.

6.1.3 Lubrication

The type and amount of the grease used to lubricate the printer parts are determined based on the results of the internal evaluations. Therefore, be sure to apply the specified type and amount of the grease to the specified part of the printer mechanism on the following occasion.

- Any parts required the lubrication are replaced.
- The printer is disassembled/assembled. (If necessary)

CAUTION !	<ul style="list-style-type: none"> ■ Never use oil or grease other than those specified in this manual. Use of different types of oil or grease may damage the component or give bad influence on the printer function. ■ Never apply larger amount of grease than specified in this manual.
---------------------	--

Table 6-1. Specified Lubricant

Type	Name	EPSON Code	Supplier
Grease	G-8AF	TBD	EPSON

- Refer to the following figures for the lubrication points.

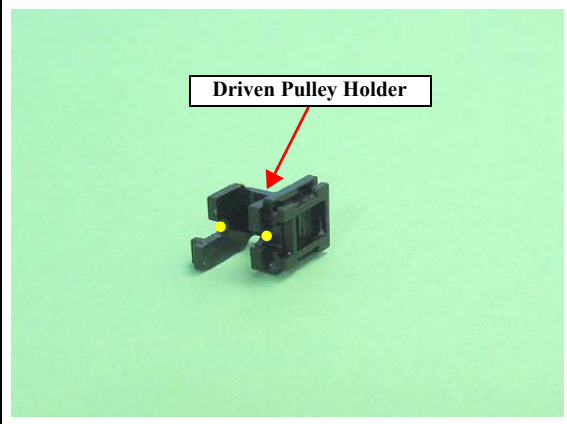
	<Lubrication Point> Contact points (x 2) with the Pulley.
	<Lubrication Type> G-8AF
	<Lubrication Amount> Size of a grain of rice
	<Remarks> Use an injector to apply G-71.

Figure 6-1. Lubrication on Driven Pulley Holder

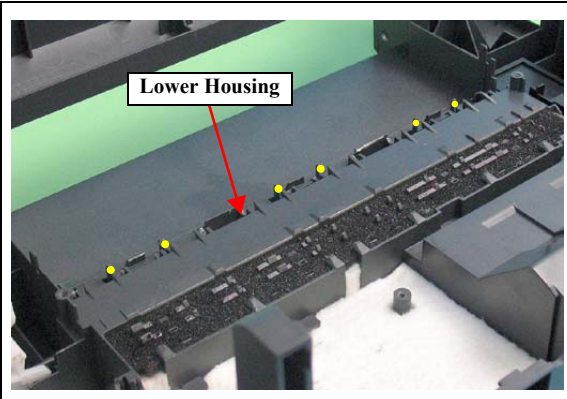
	<Lubrication Point> Contact points (x 2) with the EJ Roller.
	<Lubrication Type> G-8AF
	<Lubrication Amount> Adequate dose
	<Remarks> <input type="checkbox"/> Before installing the EJ Roller. <input type="checkbox"/> Use an injector.

Figure 6-2. Lubrication on Lower Housing (1)

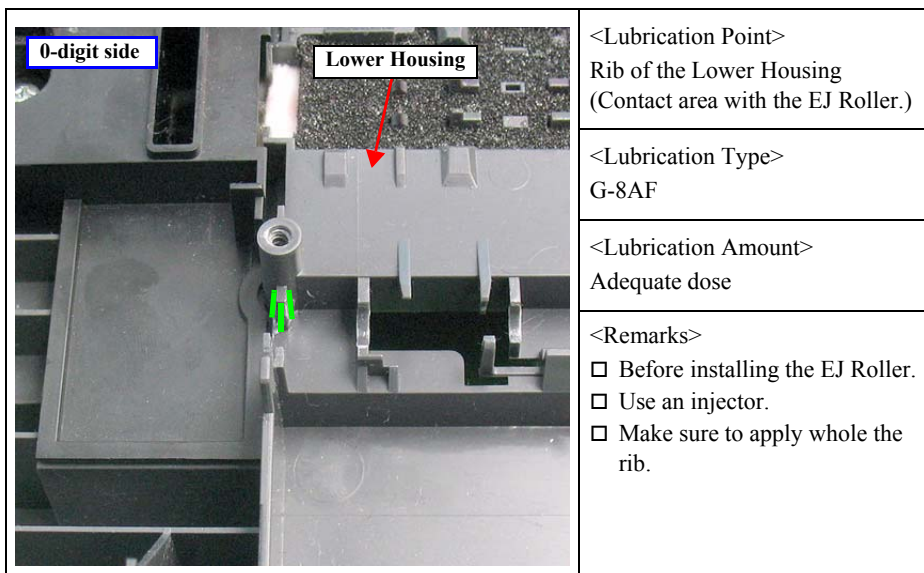


Figure 6-3. Lubrication on Lower Housing (2)

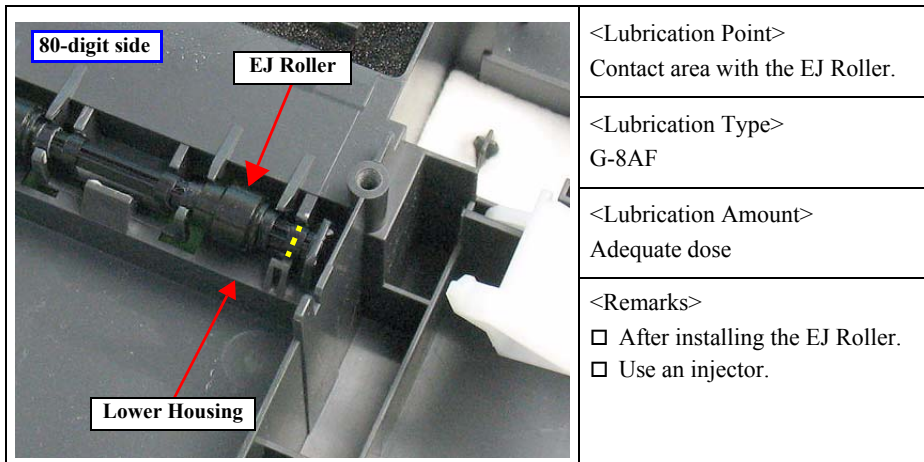


Figure 6-4. Lubrication on Lower Housing (3)

CHAPTER

7

APPENDIX

7.1 Exploded Diagram / Parts List

This manual does not provide exploded diagrams or parts list.
For the information, see SPI (Service Parts Information).